

SOME TERMINATION COMPONENTS ARE OPTIONAL ONLY REFER TO BOM(S) FOR TYPICAL COMPONENT INSTALLATION INFORMATION.

REVISIONS			
REV	DESCRIPTION	DATE	APPROVED
A	INITIAL RELEASE	29FEB08	D. Zhu

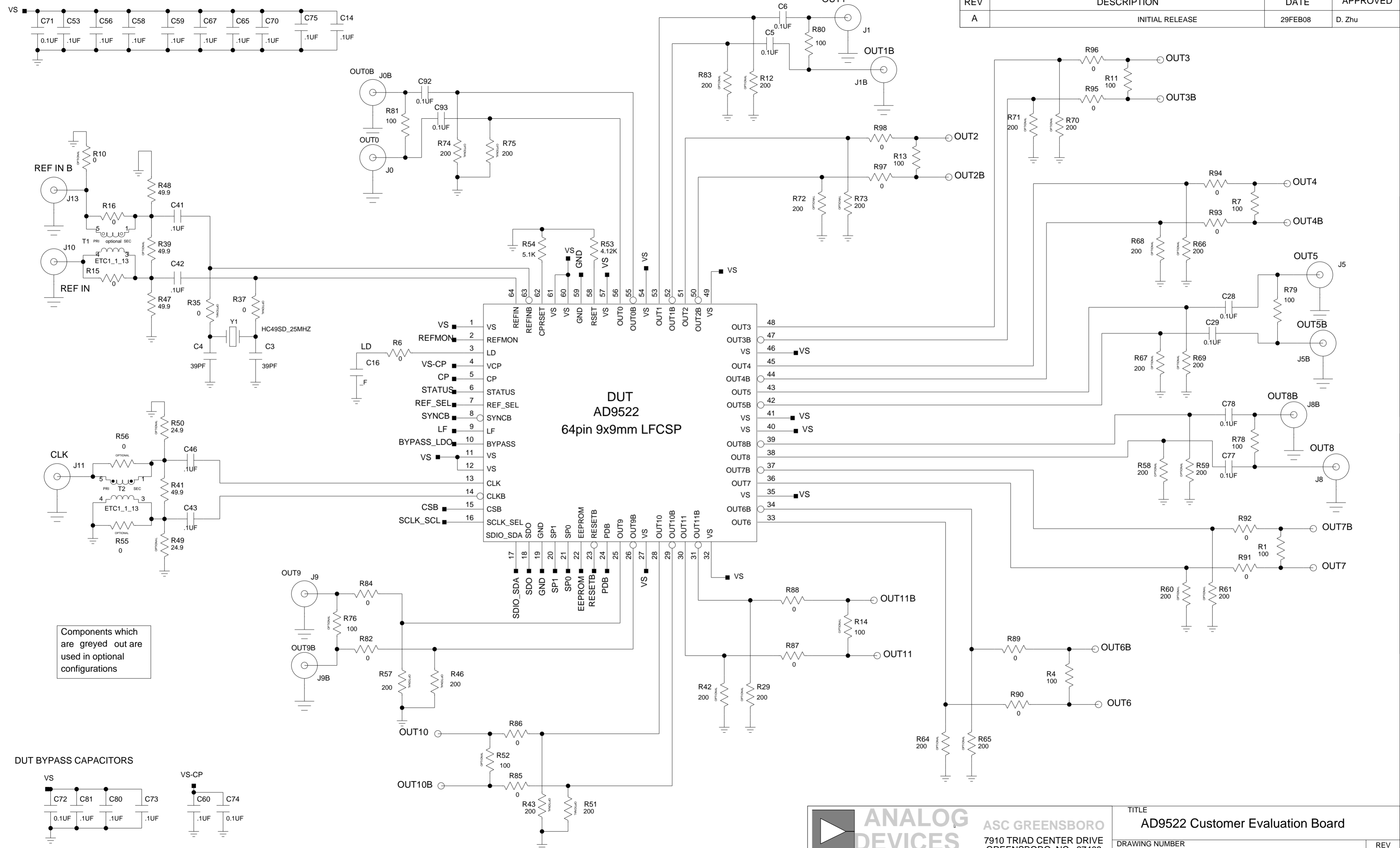

Components which are greyed out are used in optional configurations

DUT BYPASS CAPACITORS

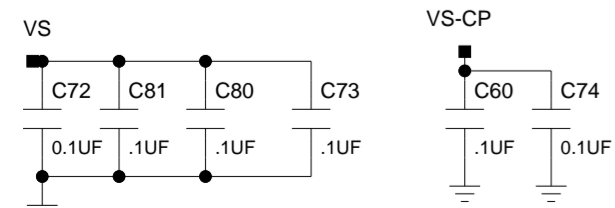

	ASC GREENSBORO 7910 TRIAD CENTER DRIVE GREENSBORO NC 27409		TITLE AD9522 Customer Evaluation Board	
	DATE: May 08, 2008	SHEET 1 OF 3	DRAWN BY: A. MACK	DRAWING NUMBER 9522CE01

REVISIONS			
REV	DESCRIPTION	DATE	APPROVED

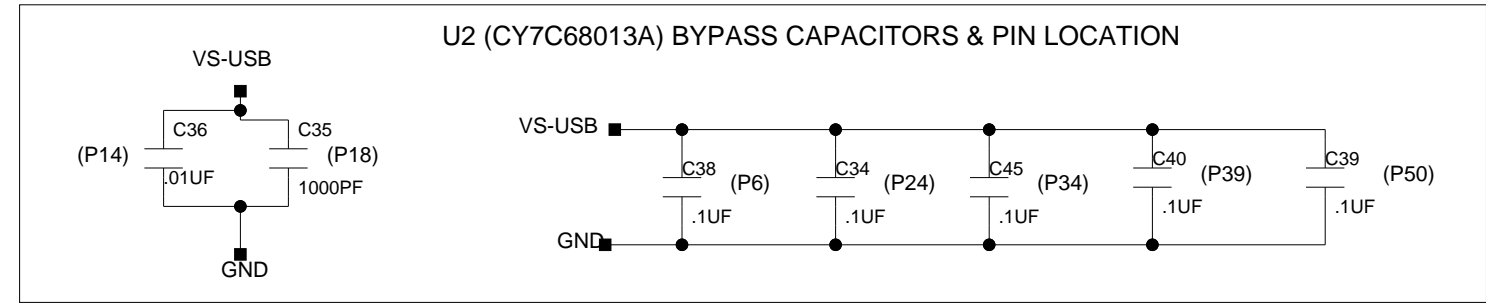
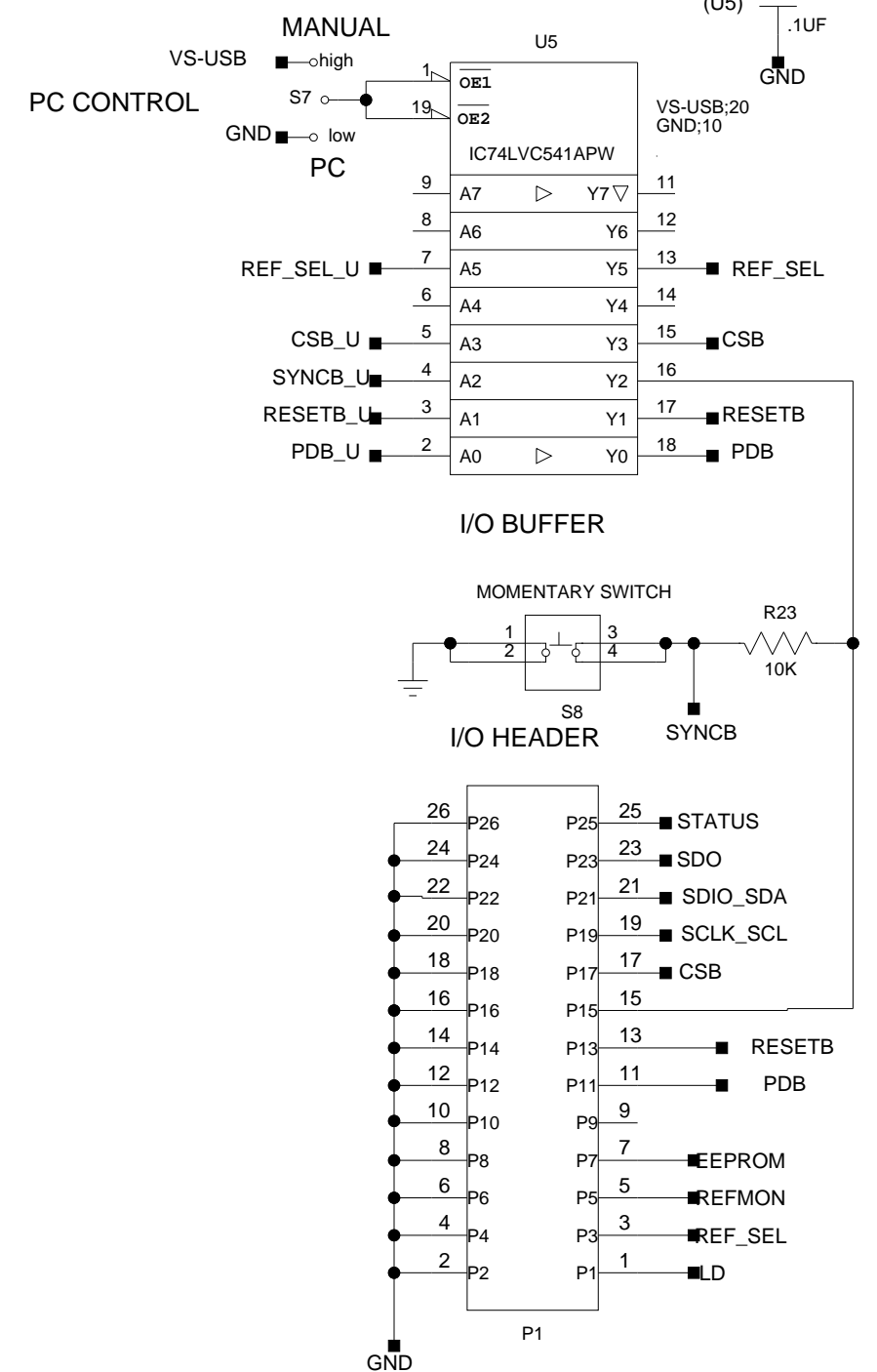
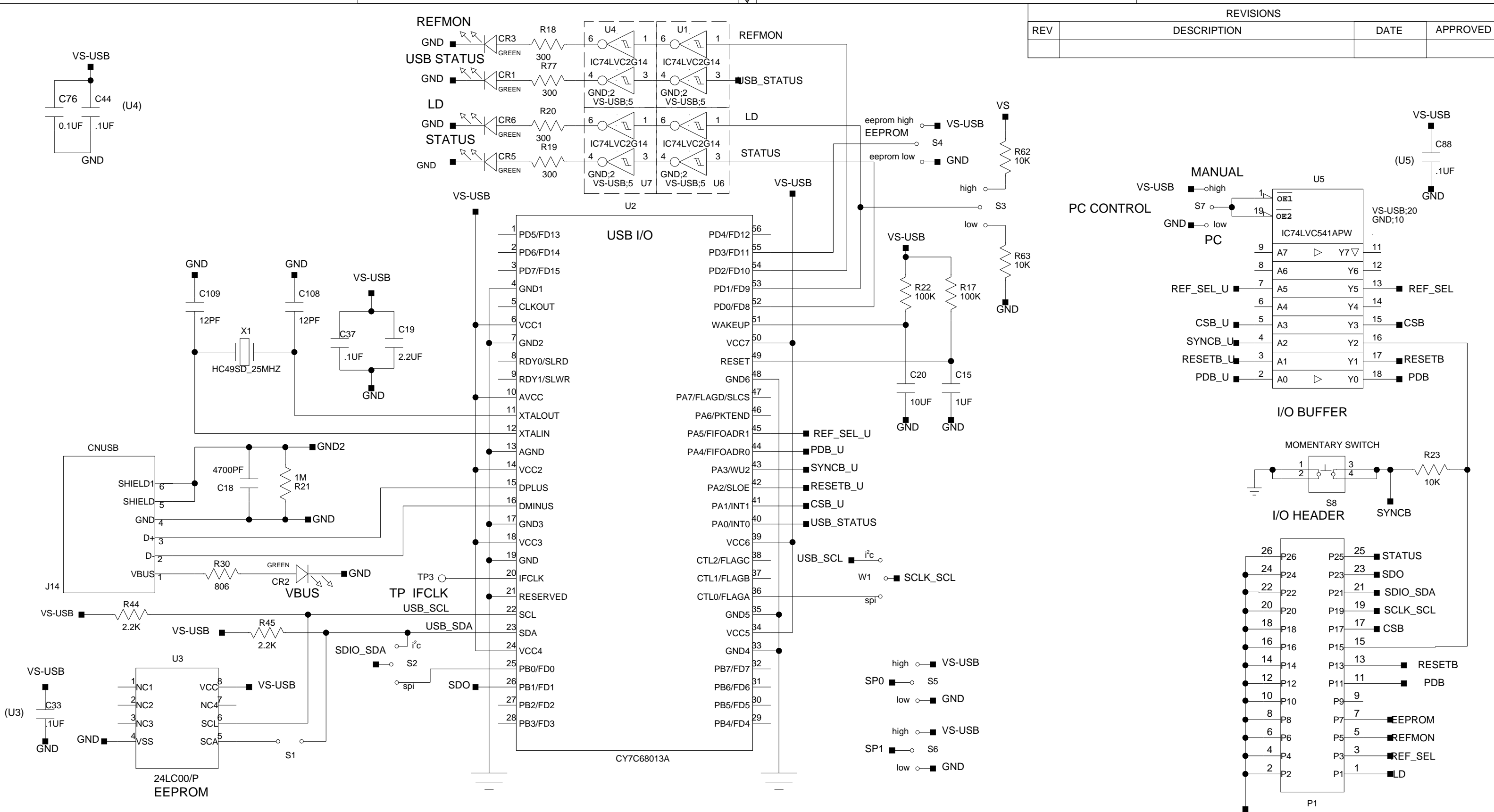



ASC GREENSBORO
7910 TRIAD CENTER DRIVE
GREENSBORO NC 27409

TITLE
AD9522 Customer Evaluation Board

DRAWING NUMBER
9522CE01

REV
A

DATE: May 8, 2008

SHEET 2 OF 3

DRAWN BY: A. MACK

REVISIONS			
REV	DESCRIPTION	DATE	APPROVED

CHARGE PUMP FILTER

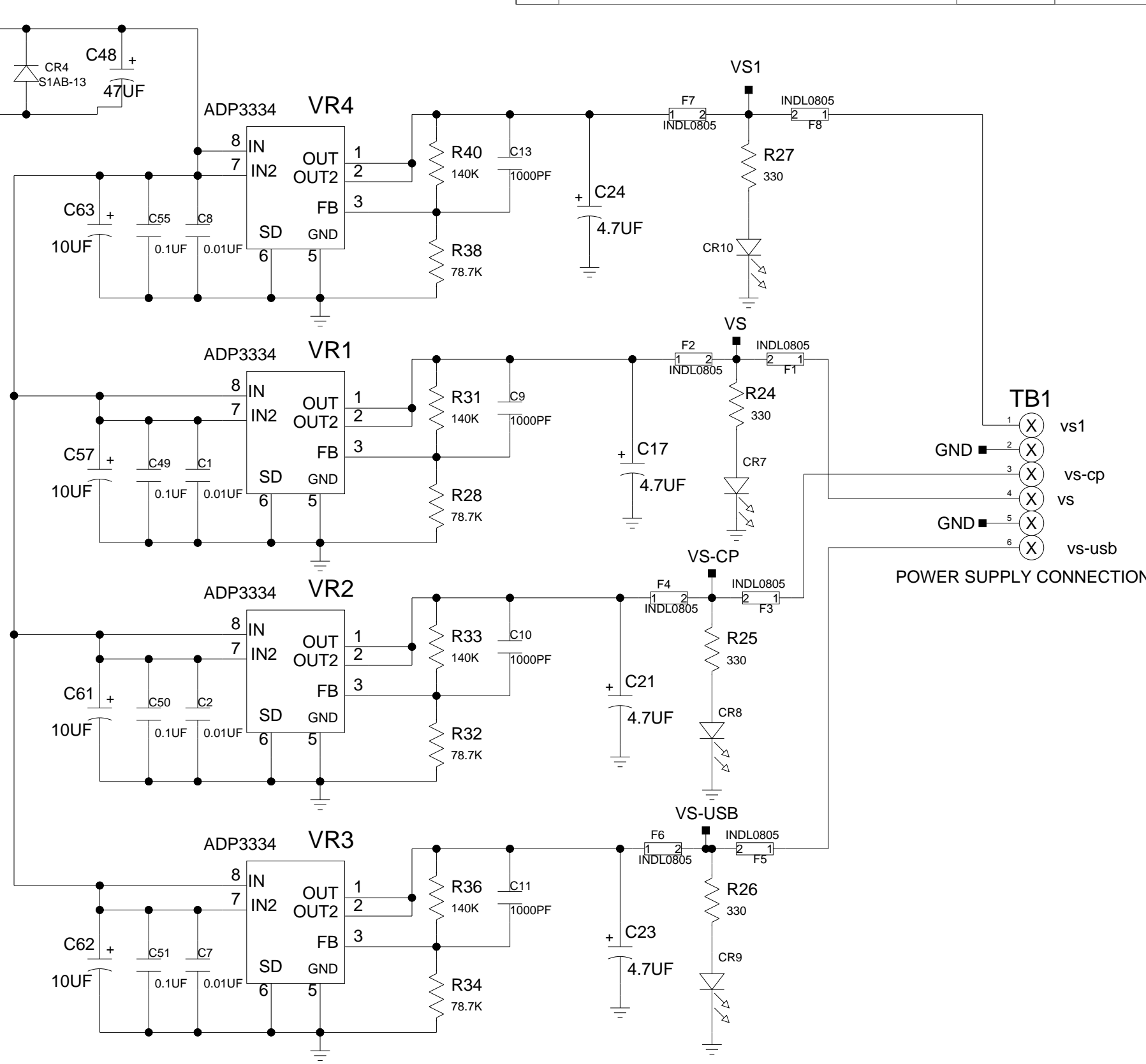
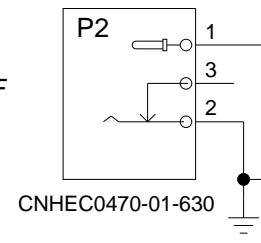
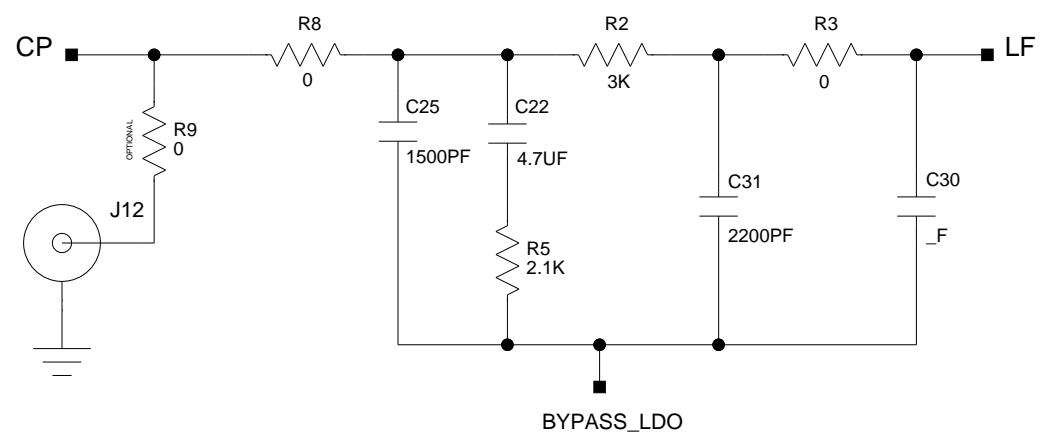

POWER SUPPLY BYPASS CAPACITORS

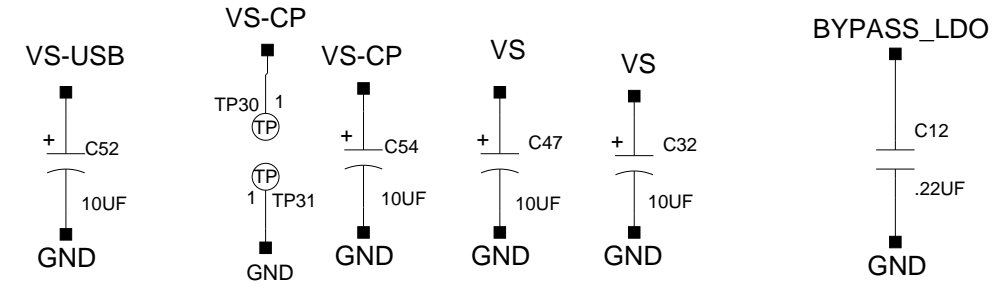

TEST POINT GROUNDS

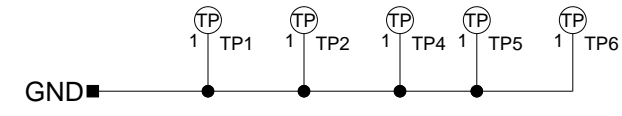

	ASC GREENSBORO 7910 TRIAD CENTER DRIVE GREENSBORO NC 27409	TITLE AD9522 Customer Evaluation Board	DRAWING NUMBER 9522CE01	REV A
	DATE: May 8, 2008	SHEET 3 OF 3	DRAWN BY: A. MACK	