

# **ADSP-21364 EZ-KIT Lite® Evaluation System Manual**

Revision 3.3, August 2012

Part Number  
82-000840-01

Analog Devices, Inc.  
One Technology Way  
Norwood, Mass. 02062-9106



## Copyright Information

© 2012 Analog Devices, Inc., ALL RIGHTS RESERVED. This document may not be reproduced in any form without prior, express written consent from Analog Devices, Inc.

Printed in the USA.

## Disclaimer

Analog Devices, Inc. reserves the right to change this product without prior notice. Information furnished by Analog Devices is believed to be accurate and reliable. However, no responsibility is assumed by Analog Devices for its use; nor for any infringement of patents or other rights of third parties which may result from its use. No license is granted by implication or otherwise under the patent rights of Analog Devices, Inc.

## Trademark and Service Mark Notice

The Analog Devices logo, CrossCore, EngineerZone, EZ-Extender, EZ-KIT Lite, SHARC, and VisualDSP++ are registered trademarks of Analog Devices, Inc.

All other brand and product names are trademarks or service marks of their respective owners.

## Regulatory Compliance

The ADSP-21364 EZ-KIT Lite evaluation system is designed to be used solely in a laboratory environment. The board is not intended for use as a consumer end product or as a portion of a consumer end product. The board is an open system design which does not include a shielded enclosure and therefore may cause interference to other electrical devices in close proximity. This board should not be used in or near any medical equipment or RF devices.

The ADSP-21364 EZ-KIT Lite evaluation system has been certified to comply with the essential requirements of the European EMC directive 89/336/EEC (inclusive 93/68/EEC) and, therefore, carries the “CE” mark.

The ADSP-21364 EZ-KIT Lite has been appended to Analog Devices, Inc. EMC Technical File (EMC TF) referenced **DSPTOOLS1**, issue 2 dated September 15, 2004 and was declared CE compliant by an appointed Notified Body (No.0673) as listed below.

Notified Body Statement of Compliance: Z600ANA1.020



Issued by: Technology International (Europe) Limited  
60 Shrivenham Hundred Business Park  
Shrivenham, Swindon, SN6 8TY, UK

The EZ-KIT Lite evaluation system contains ESD (electrostatic discharge) sensitive devices. Electrostatic charges readily accumulate on the human body and equipment and can discharge without detection. Permanent damage may occur on devices subjected to high-energy discharges. Proper ESD precautions are recommended to avoid performance degradation or loss of functionality. Store unused EZ-KIT Lite boards in the protective shipping package.





# CONTENTS

## PREFACE

Product Overview .....	x
Purpose of This Manual .....	xii
Intended Audience .....	xii
Manual Contents .....	xiii
What's New in This Manual .....	xiv
Technical Support .....	xiv
Supported Processors .....	xv
Product Information .....	xv
Analog Devices Web Site .....	xv
EngineerZone .....	xvi
Related Documents .....	xvii
Notation Conventions .....	xvii

## USING THE ADSP-21364 EZ-KIT LITE

Package Contents .....	1-2
Default Configuration .....	1-3
CCES Install and Session Startup .....	1-4
Session Startup .....	1-6

# Contents

VisualDSP++ Install and Session Startup .....	1-8
Session Startup .....	1-9
CCES Evaluation License .....	1-10
VisualDSP++ Evaluation License .....	1-11
External Memory .....	1-12
Analog Audio .....	1-13
LEDs and Push Buttons .....	1-14
Example Programs .....	1-16
Board Design Database .....	1-16

## ADSP-21364 EZ-KIT LITE HARDWARE REFERENCE

System Architecture .....	2-2
Parallel Port .....	2-3
DAI Interface .....	2-4
SPI Interface .....	2-6
FLAG Pins .....	2-6
Expansion Interface .....	2-7
JTAG Emulation Port .....	2-8
Switch Settings .....	2-9
Electret Microphone Select Switch (SW6) .....	2-9
Codec Setup Switch (SW7) .....	2-10
SPI Disable Switch (SW8) .....	2-11
Push Button Enable Switch (SW9) .....	2-11
Boot Mode and Clock Ratio Select Switch (SW10) .....	2-12
Loop-Back Test Switch (SW11) .....	2-13

LEDs and Push Buttons .....	2-13
General Purpose LEDs (LED8–1) .....	2-14
Reset LED (LED9) .....	2-14
Power LED (LED10) .....	2-14
USB Monitor LED (ZLED3) .....	2-14
Push Buttons (SW1–4) .....	2-15
Board Reset Push Button (SW5) .....	2-15
Connectors .....	2-16
Expansion Interface (J1–J3) .....	2-17
Audio In RCA Connector (J4) .....	2-17
Audio Out RCA Connector (J5) .....	2-18
Headphone Out Jack (J6) .....	2-18
Power Jack (J7) .....	2-18
S/PDIF Coax Connectors (J8 and J9) .....	2-19
SPI Header (P2) .....	2-19
DAI Header (P3) .....	2-20
USB Connector (ZJ1) .....	2-20
JTAG Header (ZP4) .....	2-21

## **ADSP-21364 EZ-KIT LITE BILL OF MATERIALS**

## **ADSP-21364 EZ-KIT LITE SCHEMATIC**

## **INDEX**

# Contents



# PREFACE

Thank you for purchasing the ADSP-21364 EZ-KIT Lite<sup>®</sup>, Analog Devices, Inc. evaluation system for SHARC<sup>®</sup> processors.

SHARC processors are based on a 32-bit super Harvard architecture that includes a unique memory architecture comprised of two large on-chip, dual-ported SRAM blocks coupled with a sophisticated IO processor, which gives a SHARC processor the bandwidth for sustained high-speed computations. SHARC processors represents today's de facto standard for floating-point processor targeted for premium audio applications.

The evaluation system is designed to be used in conjunction with the CrossCore<sup>®</sup> Embedded Studio (CCES) and VisualDSP++<sup>®</sup> development environments to demonstrate capabilities of the ADSP-21364 SHARC processors. The development environment aids advanced application code development and debug, such as:

- Create, compile, assemble, and link application programs written in C++, C, and ADSP-21364 assembly
- Load, run, step, halt, and set breakpoints in application program
- Read and write data and program memory
- Read and write core and peripheral registers
- Plot memory

Access to the ADSP-21364 processor from a personal computer (PC) is achieved through a USB port or an optional JTAG emulator. The USB interface gives unrestricted access to the ADSP-21364 processor and the

## Product Overview

evaluation board peripherals. Analog Devices JTAG emulators offer faster communication between the host PC and target hardware. Analog Devices carries a wide range of in-circuit emulation products. To learn more about Analog Devices emulators and processor development tools, go to <http://www.analog.com/dsp/tools>.

The ADSP-21364 EZ-KIT Lite provides example programs to demonstrate the capabilities of the evaluation board.

## Product Overview

The board features:

- Analog Devices ADSP-21364 processor
  - 136-pin BGA package
  - 300 MHz core clock speed
- Synchronous random access memory (SRAM)
  - 512K bit x 8-bit
- Flash memory
  - 1M x 8-bit
- Serial peripheral interface (SPI) flash memory
  - 2M bit

- Analog audio interface
  - AD1835A codec
  - 4x2 RCA phono jack for 4 channels of stereo output
  - 2x1 RCA phono jack for 1 channel of stereo input
  - Headphone jack for 1 channel stereo output
- Digital audio interface
  - RCA phono jack output
  - RCA phono jack input
- LEDs
  - 11 LEDs: 1 power (green), 1 board reset (red), 1 USB monitor (amber), and 8 general purpose (amber)
- Push buttons
  - 5 push buttons: 1 reset, 2 connected to DAI, 2 connected to the FLAG pins of the processor
- Expansion interface (type A)
  - Parallel port, FLAGs, DAI, SPI
- Other features
  - JTAG ICE 14-pin header
  - 0-ohm resistors for processor current measurement
  - SPI header
  - DAI header

## Purpose of This Manual

The EZ-KIT Lite board has a total of 1 MB of parallel flash memory and 2 MB of SPI flash memory. Flash memories can store user-specific boot code, allowing the board to run as a standalone unit. For more information, see [“External Memory” on page 1-12](#) and [“Boot Mode and Clock Ratio Select Switch \(SW10\)” on page 2-12](#). The board also has 512 KB of SRAM, which can be used at runtime.

The DAI of the processor connects to the AD1835A audio codec and two connectors, which allow Sony/Philips Digital Interface (S/PDIF) input and output. The interface facilitates development of digital and analog audio signal-processing applications. See [“Analog Audio” on page 1-13](#) and [“S/PDIF Coax Connectors \(J8 and J9\)” on page 2-19](#) for more information.

Additionally, the EZ-KIT Lite board provides access to all of the processor’s peripheral ports. Access is provided in the form of a three-connector expansion interface. See [“Expansion Interface” on page 2-7](#) for details.

## Purpose of This Manual

The *ADSP-21364 EZ-KIT Lite Evaluation System Manual* provides instructions for installing the product hardware (board). The text describes operation and configuration of the board components and provides guidelines for running your own code on the ADSP-21364 EZ-KIT Lite. Finally, a schematic and a bill of materials are provided as a reference for future designs.

## Intended Audience

The primary audience for this manual is a programmer who is familiar with Analog Devices processors. This manual assumes that the audience has a working knowledge of the appropriate processor architecture and instruction set.

Programmers who are unfamiliar with Analog Devices processors can use this manual but should supplement it with other texts that describe your target architecture. For the locations of these documents, see [“Related Documents”](#).

Programmers who are unfamiliar with CCES or VisualDSP++ should refer to the online help and the user’s manuals.

## Manual Contents

The manual consists of:

- Chapter 1, [“Using the ADSP-21364 EZ-KIT Lite” on page 1-1](#)  
Provides information on the EZ-KIT Lite from a programmer’s perspective and provides an easy-to-access memory map.
- Chapter 2, [“ADSP-21364 EZ-KIT Lite Hardware Reference” on page 2-1](#)  
Provides information on the hardware aspects of the evaluation system.
- Appendix A, [“ADSP-21364 EZ-KIT Lite Bill of Materials” on page A-1](#)  
Provides a list of components used to manufacture the EZ-KIT Lite board.
- Appendix B, [“ADSP-21364 EZ-KIT Lite Schematic” on page B-1](#)  
Provides the resources to allow modifications to the EZ-KIT Lite or to use as a reference guide. Appendix B is part of the online help.

# What's New in This Manual

This is revision 3.3 of the *ADSP-21364 EZ-KIT Lite Evaluation System Manual*. The manual has been updated to include CCES information. In addition, modifications and corrections based on errata reports against the previous manual revision have been made.

For the latest version of this manual, please refer to the Analog Devices Web site.

## Technical Support

You can reach Analog Devices processors and DSP technical support in the following ways:

- Post your questions in the processors and DSP support community at EngineerZone<sup>®</sup>:  
<http://ez.analog.com/community/dsp>
- Submit your questions to technical support directly at:  
<http://www.analog.com/support>
- E-mail your questions about processors, DSPs, and tools development software from **CrossCore Embedded Studio** or **VisualDSP++**:

Choose **Help > Email Support**. This creates an e-mail to [processor.tools.support@analog.com](mailto:processor.tools.support@analog.com) and automatically attaches your **CrossCore Embedded Studio** or **VisualDSP++** version information and `license.dat` file.

- E-mail your questions about processors and processor applications to:  
[processor.support@analog.com](mailto:processor.support@analog.com) or  
[processor.china@analog.com](mailto:processor.china@analog.com) (Greater China support)

- In the **USA only**, call **1-800-ANALOGD** (1-800-262-5643)
- Contact your Analog Devices sales office or authorized distributor.  
Locate one at:  
[www.analog.com/adi-sales](http://www.analog.com/adi-sales)
- Send questions by mail to:  
Processors and DSP Technical Support  
Analog Devices, Inc.  
Three Technology Way  
P.O. Box 9106  
Norwood, MA 02062-9106  
USA

## Supported Processors

The ADSP-21364 EZ-KIT Lite evaluation system supports the Analog Devices ADSP-21364 SHARC processors.

## Product Information

Product information can be obtained from the Analog Devices Web site and the online help system.

## Analog Devices Web Site

The Analog Devices Web site, [www.analog.com](http://www.analog.com), provides information about a broad range of products—analogue integrated circuits, amplifiers, converters, and digital signal processors.

To access a complete technical library for each processor family, go to [http://www.analog.com/processors/technical\\_library](http://www.analog.com/processors/technical_library). The manuals selection opens a list of current manuals related to the product as well as a

## Product Information

link to the previous revisions of the manuals. When locating your manual title, note a possible errata check mark next to the title that leads to the current correction report against the manual.

Also note, [myAnalog](#) is a free feature of the Analog Devices Web site that allows customization of a Web page to display only the latest information about products you are interested in. You can choose to receive weekly e-mail notifications containing updates to the Web pages that meet your interests, including documentation errata against all manuals. [myAnalog](#) provides access to books, application notes, data sheets, code examples, and more.

Visit [myAnalog](#) (found on the Analog Devices home page) to sign up. If you are a registered user, just log on. Your user name is your e-mail address.

## EngineerZone

EngineerZone is a technical support forum from Analog Devices. It allows you direct access to ADI technical support engineers. You can search FAQs and technical information to get quick answers to your embedded processing and DSP design questions.

Use EngineerZone to connect with other DSP developers who face similar design challenges. You can also use this open forum to share knowledge and collaborate with the ADI support team and your peers. Visit <http://ez.analog.com> to sign up.



## Related Documents

For additional information about the product, refer to the following publications.

Table 1. Related Processor Publications

Title	Description
<i>ADSP-21362/ADSP-21363/ADSP-21364/ADSP-21365/ADSP-21366 SHARC Processor Data Sheet</i>	General functional description, pinout, and timing of the processor
<i>ADSP-2136x SHARC Processor Hardware Reference</i>	Description of the internal processor architecture, registers, and all peripheral functions
<i>SHARC Processor Programming Reference</i>	Description of all allowed processor assembly instructions





If you plan to use the EZ-KIT Lite board in conjunction with a JTAG emulator, also refer to the documentation that accompanies the emulator.

## Notation Conventions

Text conventions used in this manual are identified and described as follows.

Example	Description
<b>Close</b> command (File menu)	Titles in reference sections indicate the location of an item within the development environment's menu system (for example, the <b>Close</b> command appears on the <b>File</b> menu).
{this   that}	Alternative required items in syntax descriptions appear within curly brackets and separated by vertical bars; read the example as <i>this</i> or <i>that</i> . One or the other is required.
[this   that]	Optional items in syntax descriptions appear within brackets and separated by vertical bars; read the example as an optional <i>this</i> or <i>that</i> .

## Notation Conventions

Example	Description
[this,...]	Optional item lists in syntax descriptions appear within brackets delimited by commas and terminated with an ellipse; read the example as an optional comma-separated list of <i>this</i> .
.SECTION	Commands, directives, keywords, and feature names are in text with letter gothic font.
<i>filename</i>	Non-keyword placeholders appear in text with italic style format.
	<p><b>Note:</b> For correct operation, ...</p> <p>A Note provides supplementary information on a related topic. In the online version of this book, the word <b>Note</b> appears instead of this symbol.</p>
	<p><b>Caution:</b> Incorrect device operation may result if ...</p> <p><b>Caution:</b> Device damage may result if ...</p> <p>A Caution identifies conditions or inappropriate usage of the product that could lead to undesirable results or product damage. In the online version of this book, the word <b>Caution</b> appears instead of this symbol.</p>
	<p><b>Warning:</b> Injury to device users may result if ...</p> <p>A Warning identifies conditions or inappropriate usage of the product that could lead to conditions that are potentially hazardous for the devices users. In the online version of this book, the word <b>Warning</b> appears instead of this symbol.</p>

# 1 USING THE ADSP-21364 EZ-KIT LITE

This chapter provides specific information to assist you with development of programs for the ADSP-21364 EZ-KIT Lite evaluation system.

The information appears in the following sections.

- [“Package Contents” on page 1-2](#)  
Lists the items contained in your EZ-KIT Lite package.
- [“Default Configuration” on page 1-3](#)  
Shows the default configuration of the EZ-KIT Lite board.
- [“CCES Install and Session Startup” on page 1-4](#)  
Instructs how to start a new or open an existing EZ-KIT Lite session using CCES.
- [“VisualDSP++ Install and Session Startup” on page 1-8](#)  
Instructs how to start a new or open an existing EZ-KIT Lite session using VisualDSP++.
- [“CCES Evaluation License” on page 1-10](#)  
Describes the CCES demo license shipped with the EZ-KIT Lite.
- [“VisualDSP++ Evaluation License” on page 1-11](#)  
Describes the VisualDSP++ demo license shipped with the EZ-KIT Lite.
- [“External Memory” on page 1-12](#)  
Describes how to access external memory; defines the memory map of the EZ-KIT Lite.

## Package Contents

- [“Analog Audio” on page 1-13](#)  
Describes how to set up and communicate with the on-board audio codec.
- [“LEDs and Push Buttons” on page 1-14](#)  
Describes the board’s general-purpose I/O pins and buttons.
- [“Example Programs” on page 1-16](#)  
Provides information about example programs included in the evaluation system.
- [“Board Design Database” on page 1-16](#)  
Highlights the available technical resources for the design, layout, fabrication, and assembly of the EZ-KIT Lite.

For information on the graphical user interface, including the boot loading, target options, and other facilities of the EZ-KIT Lite system, refer to the online help.

For detailed information on how to program the ADSP-21364 SHARC processor, refer to the documents referenced in [“Related Documents”](#).

## Package Contents

Your ADSP-21364 EZ-KIT Lite evaluation system package contains the following items.

- ADSP-21364 EZ-KIT Lite board
- Universal 7V DC power supply
- USB 2.0 cable

If any item is missing, contact the vendor where you purchased your EZ-KIT Lite or contact Analog Devices, Inc.

## Default Configuration

The EZ-KIT Lite evaluation system contains ESD (electrostatic discharge) sensitive devices. Electrostatic charges readily accumulate on the human body and equipment and can discharge without detection. Permanent damage may occur on devices subjected to high-energy discharges. Proper ESD precautions are recommended to avoid performance degradation or loss of functionality. Store unused EZ-KIT Lite boards in the protective shipping package.



The ADSP-21364 EZ-KIT Lite board is designed to run outside your personal computer as a standalone unit. You do not have to open your computer case.

When removing the EZ-KIT Lite board from the package, handle the board carefully to avoid the discharge of static electricity, which may damage some components. [Figure 1-1](#) shows the default DIP switch, connector locations, and LEDs used in installation. Confirm that your board is set up in the default configuration before continuing.

# CCES Install and Session Startup

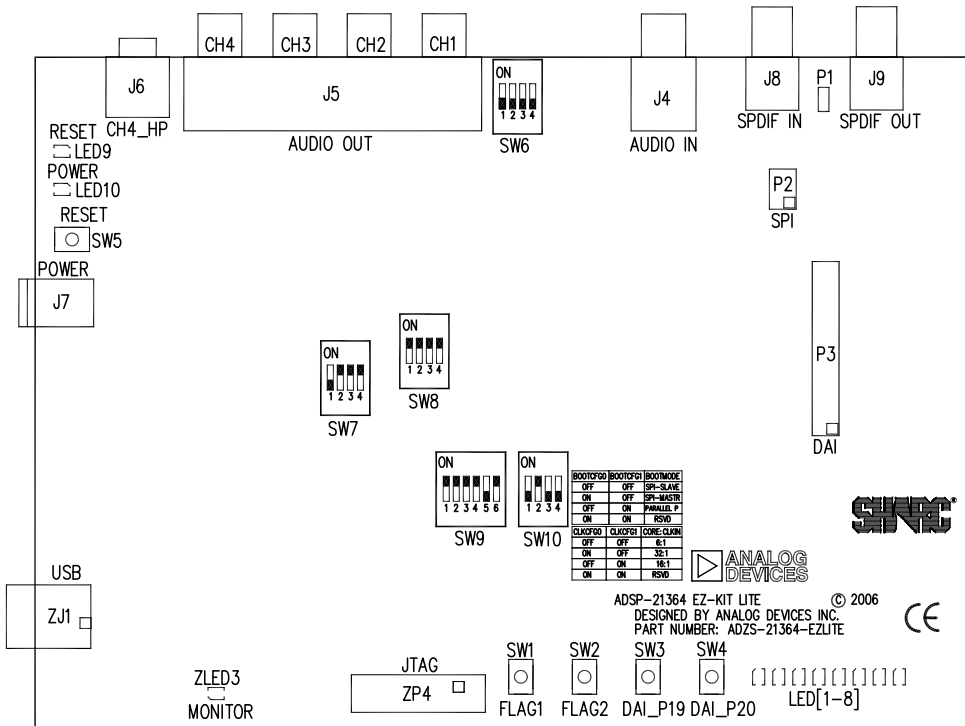

Figure 1-1. EZ-KIT Lite Hardware Setup

# CCES Install and Session Startup

For information about CCES and to download the software, go to [www.analog.com/CCES](http://www.analog.com/CCES). A link for the ADSP-21364 EZ-KIT Lite Board Support Package (BSP) for CCES can be found at <http://www.analog.com/SHARC/EZKits>.

Follow these instructions to ensure correct operation of the product software and hardware.

**Step 1:** Connect the EZ-KIT Lite board to a personal computer (PC) running CCES using one of two options: an Analog Devices emulator or via the debug agent.

### Using an Emulator:

1. Plug one side of the USB cable into the USB connector of the emulator. Plug the other side into a USB port of the PC running CCES.
2. Attach the emulator to the header connector ZP4 (labeled JTAG) on the EZ-KIT Lite board.

### Using the on-board Debug Agent:

1. Plug one side of the USB cable into the USB connector of the debug agent ZJ1 (labeled USB).
2. Plug the other side of the cable into a USB port of the PC running CCES.

**Step 2:** Attach the provided cord and appropriate plug to the 7V power adaptor.

1. Plug the jack-end of the power adaptor into the power connector J7 on the EZ-KIT Lite board.
2. Plug the other side of the power adaptor into a power outlet. The power LED (labeled LED10) is lit green when power is applied to the board.
3. Power the emulator (if used). Plug the jack-end of the assembled power adaptor into the emulator and plug the other side of the power adaptor into a power outlet. The enable/power indicator is lit green when power is applied.

## CCES Install and Session Startup

**Step 3 (if connected through the debug agent):** Verify that the yellow USB monitor LED (labeled ZLED3) and the green power LED (labeled ZLED4) on the debug agent are both on. This signifies that the board is communicating properly with the host PC and ready to run CCES.

### Session Startup

It is assumed that the CrossCore Embedded Studio software is installed and running on your PC.



Note: If you connect the board or emulator first (before installing CCES) to the PC, the Windows driver wizard may not find the board drivers.

1. Navigate to the CCES environment via the **Start** menu.

Note that CCES is not connected to the target board.

2. Use the system configuration utility to connect to the EZ-KIT Lite board.

If a debug configuration exists already, select the appropriate configuration and click **Apply and Debug** or **Debug**. Go to step 8.

To create a debug configuration, do one of the following:

- Click the down arrow next to the little bug icon, select **Debug Configurations**
- Choose **Run > Debug Configurations**.

The **Debug Configuration** dialog box appears.

3. Select **CrossCore Embedded Studio Application** and click  (New launch configuration).

The **Select Processor** page of the **Session Wizard** appears.



4. Ensure **Blackfin** is selected in **Processor family**. In **Processor type**, select **ADSP-21364**. Click **Next**.

The **Select Connection Type** page of the **Session Wizard** appears.

5. Select one of the following:
  - For standalone debug agent connections, **EZ-KIT Lite** and click **Next**.
  - For emulator connections, **Emulator** and click **Next**.

The **Select Platform** page of the **Session Wizard** appears.

6. Do one of the following:
  - For standalone debug agent connections, ensure that the selected platform is **ADSP-21364 EZ-KIT Lite** via **Debug Agent**.
  - For emulator connections, choose the type of emulator that is connected to the board.



7. Click **Finish** to close the wizard.

The new debug configuration is created and added to the program(s) to load list.

8. In the **Program(s) to load** section, choose the program to load when connecting to the board. If not loading any program upon connection to the target, do not make any changes.

Note that while connected to the target, there is no way to choose a program to download. To load a program once connected, terminate the session.

## VisualDSP++ Install and Session Startup

 To delete a configuration, go to the **Debug Configurations** dialog box and select the configuration to delete. Click  and choose **Yes** when asked if you wish to delete the selected launch configuration. Then **Close** the dialog box.

 To disconnect from the target board, click the terminate button (red box) or choose **Run > Terminate**.

To delete a session, choose **Target > Session > Session List**. Select the session name from the list and click **Delete**. Click **OK**.

## VisualDSP++ Install and Session Startup

For information about VisualDSP++ and to download the software, go to [www.analog.com/VisualDSP](http://www.analog.com/VisualDSP).

1. Plug the provided power supply into J7 on the EZ-KIT Lite board. Visually verify that the green power LED (LED10) is on.
2. Verify that the red reset LED (LED9) goes on for a moment and then goes off, and, finally, LED1 through LED8 are blinking sequentially.
3. Connect one end of the USB cable to an available full speed USB port on your PC and the other end to ZJ1 on the ADSP-21364 EZ-KIT Lite board.
4. Verify that the yellow USB monitor LED (ZLED3, located near the USB connector) is lit. This signifies that the board is communicating properly with the host PC and is ready to run VisualDSP++.

## Session Startup

1. If you are running VisualDSP++ for the first time, navigate to the VisualDSP++ environment via the **Start > Programs** menu. The main window appears. Note that VisualDSP++ does not connect to any session. Skip the rest of this step to step 2.

If you have run VisualDSP++ previously, the last opened session appears on the screen. You can override the default behavior and force VisualDSP++ to start a new session by pressing and holding down the **Ctrl** key while starting VisualDSP++. Do not release the **Ctrl** key until the **Session Wizard** appears on the screen. Go to step 3.

2. To connect to a new EZ-KIT Lite session, start **Session Wizard** by selecting one of the following.
  - From the **Session** menu, **New Session**.
  - From the **Session** menu, **Session List**. Then click **New Session** from the **Session List** dialog box.
  - From the **Session** menu, **Connect to Target**.
3. The **Select Processor** page of the wizard appears on the screen. Ensure **SHARC** is selected in **Processor family**. In **Choose a target processor**, select **ADSP-21364**. Click **Next**.
4. The **Select Connection Type** page of the wizard appears on the screen. Select **ADSP-21364** and click **Next**.

## CCES Evaluation License

5. The **Select Platform** page of the wizard appears on the screen. In the **Select your platform** list, select **ADSP-21364 EZ-KIT Lite via Debug Agent**. In **Session name**, highlight or specify the session name.

The session name can be a string of any length; although, the box displays approximately 32 characters. The session name can include space characters. If you do not specify a session name, VisualDSP++ creates a session name by combining the name of the selected platform with the selected processor. The only way to change a session name later is to delete the session and open a new session.

Click **Next**.

6. The **Finish** page of the wizard appears on the screen. The page displays your selections. Check the selections. If you are not satisfied, click **Back** to make changes; otherwise, click **Finish**. VisualDSP++ creates the new session and connects to the EZ-KIT Lite. Once connected, the main window's title is changed to include the session name set in step 5.



To disconnect from a session, click the disconnect button  or select **Session > Disconnect from Target**.

To delete a session, select **Session > Session List**. Select the session name from the list and click **Delete**. Click **OK**.

## CCES Evaluation License

The ADSP-21364 EZ-KIT Lite software is part of the Board Support Package (BSP) for the SHARC ADSP-2136x family. The EZ-KIT Lite is a licensed product that offers an unrestricted evaluation license for 90 days after activation. Once the evaluation period ends, the evaluation license

becomes permanently disabled. If the evaluation license is installed but not activated, it allows 10 days of unrestricted use and then becomes disabled. The license can be re-enabled by activation.

An evaluation license can be upgraded to a full license. Licenses can be purchased from:

- Analog Devices directly. Call (800) 262-5645 or 781-937-2384 or go to:  
<http://www.analog.com/buyonline>.
- Analog Devices, Inc. local sales office or authorized distributor. To locate one, go to:  
<http://www.analog.com/salesdir/continent.asp>.

 The EZ-KIT Lite hardware must be connected and powered up to use CCES with a valid evaluation or full license.

## VisualDSP++ Evaluation License

The ADSP-21364 EZ-KIT Lite installation is part of the VisualDSP++ installation. The EZ-KIT Lite is a licensed product that offers an unrestricted evaluation license for the first 90 days. Once the initial unrestricted 90-day evaluation license expires:

1. VisualDSP++ allows a connection to the ADSP-21364 EZ-KIT Lite via the USB Debug Agent interface only. Connections to simulators and emulation products are no longer allowed.
2. The linker restricts a users program to 10922 words of memory for code space with no restrictions for data space.

 To avoid errors when opening VisualDSP++, the EZ-KIT Lite hardware must be connected and powered up. This is true for using VisualDSP++ with a valid evaluation or full license.

# External Memory

The EZ-KIT Lite contains three types of memory: parallel flash (1 MB), SPI flash (2 MB) and SRAM (512K bit). Flash memories can store user-specific boot code, allowing the board to run as a standalone unit. For more information about setting the boot device for the processor, see [“Boot Mode and Clock Ratio Select Switch \(SW10\)” on page 2-12](#).

[Table 1-1](#) provides a map of the board’s external memory.

Table 1-1. EZ-KIT Lite Evaluation Board External Memory

Start Address	End Address	Content
0x0100 0000	0x010F FFFF	Flash memory
0x0120 0000	0x0127 FFFF	SRAM memory
0x0140 0000	0x0140 FFFF	LEDs (see <a href="#">“LEDs and Push Buttons” on page 2-13</a> )
0x0160 0000	0x017F FFFF	Unused chip select 1
0x0180 0000	0x019F FFFF	Unused chip select 2

Parallel flash memory and SRAM connect to the parallel port of the processor. The parallel port is a multiplexed address and data port. The port can connect to 8-bit and 16-bit memory devices. When configuring the parallel port, keep in mind that the memory devices on the board are 8 bits wide.

To access SRAM and flash memories, set up a parallel port DMA. For more information on how to connect SRAM and flash memories, see [“Parallel Port” on page 2-3](#).

SPI flash memory connects to the SPI port of the processor and uses `FLAG0` as a chip select. In order for `FLAG0` to behave as a chip select, clear the `PPFLG` bit in the `SYSCTL` register.

An example program is included in the EZ-KIT Lite installation directory to demonstrate how the parallel port and SPI port can be configured to access the memories.

## Analog Audio

The AD1835A is a high-performance, single-chip codec featuring four stereo digital-to-analog converters (DAC) for audio output and one stereo analog-to-digital converters (ADC) for audio input. The codec can input and output data with a sample rate of up to 96 kHz on all channels. A 192 kHz sample rate can be used with the one of the DAC channels.

The processor interfaces with the AD1835A codec via the DAI port. The DAI interface pins can be configured to transfer serial data from the AD1835A codec in either time-division multiplexed (TDM) or 2-wire interface (TWI) mode. For more information on how the AD1835A connects to the DAI, see [“DAI Interface” on page 2-4](#).

The master input clock (MCLK) for the AD1835A can be generated by the on-board 12.288 MHz oscillator or can be supplied by one of the DAI pins of the processor. Using one of the pins to generate the MCLK, as opposed to the on-board oscillator, allows synchronization of multiple devices in the system. This is done on the EZ-KIT Lite when data is coming from the S/PDIF receiver and being output through the audio codec. The S/PDIF MCLK is routed to the AD1835A MCLK in the processor’s signal routing unit (SRU). It is also necessary to disable the on-board audio oscillator from driving the audio codec and the processor’s input pin. For instructions on how to configure the clock, refer to [“Codec Setup Switch \(SW7\)” on page 2-10](#).

The AD1835A codec can be configured as a master or as a slave, depending on the DIP switch settings. In master mode, the AD1835A drives the serial port clock and frame sync signals to the processor. In slave mode, the processor must generate and drive all of the serial port clock and frame

## LEDs and Push Buttons

sync signals. For information on how to set the mode, refer to [“Codec Setup Switch \(SW7\)” on page 2-10](#).

The internal configuration registers of the codec are configured using the SPI port of the processor. The `FLAG3` register is used as the select for the device. For information on how to configure the multichannel codec, refer to the product data sheet at [AD1835A](#).

The RCA connector (J4) is used to input analog audio. When using an electret microphone on this connector, configure the SW6 switch according to the instructions in [“Electret Microphone Select Switch \(SW6\)” on page 2-9](#). The four output channels connect to the RCA connector J5. Channel 4 of the codec connects to the headphone jack J6. For more information, see [“Connectors” on page 2-16](#).

Example programs are included in the EZ-KIT Lite installation directory to demonstrate how to configure and use the board’s analog audio interface.

## LEDs and Push Buttons

The EZ-KIT Lite has eight general-purpose user LEDs and four general-purpose push buttons.

Two of the general-purpose push buttons are attached to the `FLAG` pins of the processor, while the other two are attached to the `DAI` pins. All of the push buttons connect to the processor through a DIP switch. The DIP switch can disconnect processor pins attached to the push buttons. See [“Push Button Enable Switch \(SW9\)” on page 2-11](#) for instructions on how to disable the push buttons from driving the corresponding processor pins.

The value of the push buttons connected to the `FLAG` pins can be determined by reading the `FLAG` register. The push buttons connected to the



DAI pins must be configured as interrupts. It is necessary to set up an interrupt routine to determine each pin's state.

[Table 1-2](#) shows how each push button connects to the processor. Refer to the related example program shipped with the EZ-KIT Lite for more information.

Table 1-2. Push Button Connections

Push Button Reference Designator	Processor Pin
SW1	FLAG1
SW2	FLAG2
SW3	DAI_P19
SW4	DAI_P20

The LEDs connect to the parallel port pins, AD7-0, via a latch. The parallel port of the processor can be set up as a memory bus or as general-purpose FLAG pins. The latch allows the LEDs to be written to in both cases. Information about setting up the latch can be found in [“Push Button Enable Switch \(SW9\)” on page 2-11](#).

When the LEDs are accessed as FLAG pins, the latch must be set up to pass the data through to pins AD7-0 of the processor. In this mode, it is also necessary to set up the parallel port to be FLAG pins. To set up the parallel port as FLAG pins, set the PPFLGS bit in the SYSCTL register.

[Table 1-3](#) summarizes the LED and FLAG connections.

Table 1-3. LED Connections

LED Reference Designator	Processor Pin	Mapped as FLAG
LED1	AD0	FLAG8
LED2	AD1	FLAG9
LED3	AD2	FLAG10

## Example Programs

Table 1-3. LED Connections (Cont'd)

LED Reference Designator	Processor Pin	Mapped as FLAG
LED4	AD3	FLAG11
LED5	AD4	FLAG12
LED6	AD5	FLAG13
LED7	AD6	FLAG14
LED8	AD7	FLAG15

An example program is included in the EZ-KIT Lite installation directory to demonstrate functionality of the LEDs and push buttons.

## Example Programs

Example programs are provided with the ADSP-21364 EZ-KIT Lite to demonstrate various capabilities of the product. The programs are included in the product installation kit and can be found in the `Examples` folder of the installation. Refer to a readme file provided with each example for more information.

CCES users are encouraged to use the example browser to find examples included with the EZ-KIT Lite Board Support Package.

## Board Design Database

A .zip file containing all of the electronic information required for the design, layout, fabrication and assembly of the product is available for download from the Analog Devices board design database at:

<http://www.analog.com/sharc-board-design-database>.

# 2 ADSP-21364 EZ-KIT LITE HARDWARE REFERENCE

This chapter describes the hardware design of the ADSP-21364 EZ-KIT Lite board. The following topics are covered.

- [“System Architecture” on page 2-2](#)  
Describes the ADSP-21364 board configuration and explains how the board components interface with the processor.
- [“Switch Settings” on page 2-9](#)  
Shows the locations and describes the board switches.
- [“LEDs and Push Buttons” on page 2-13](#)  
Shows the locations and describes the board LEDs and push buttons.
- [“Connectors” on page 2-16](#)  
Shows the locations and provides part numbers for the on-board connectors. In addition, the manufacturer and part number information is provided for the mating parts.

## System Architecture

This section describes the processor's configuration on the EZ-KIT Lite board shown in [Figure 2-1](#).

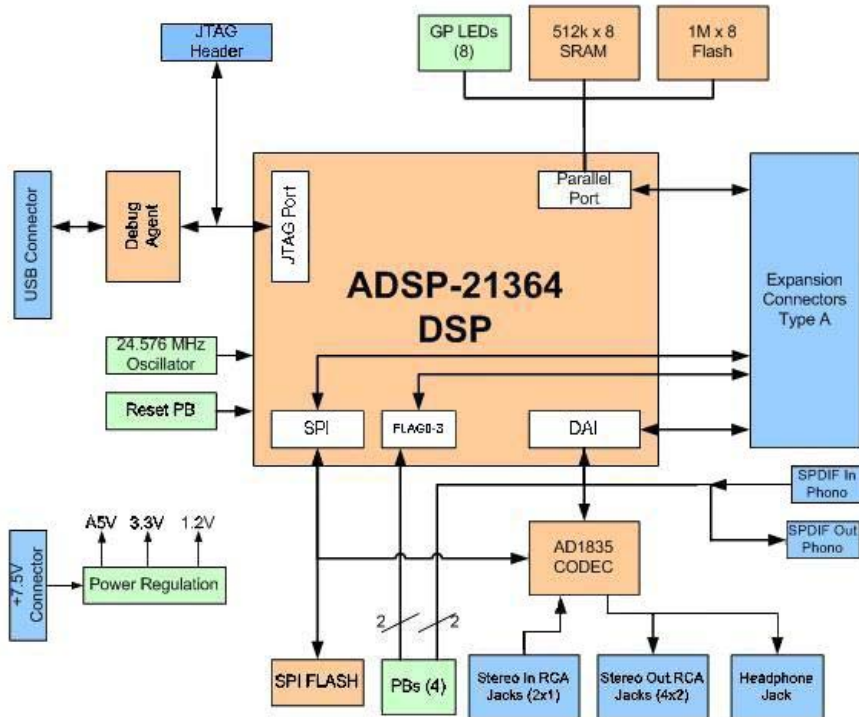

Figure 2-1. System Architecture Block Diagram

This EZ-KIT Lite has been designed to demonstrate the capabilities of the ADSP-21364 processor. The processor core is powered at 1.2V, and the IO is powered at 3.3V. Two 0-ohm resistors give access to the processor's power planes and allow to measure the power consumption of the processor. The R79 resistor provides access to the IO voltage of the processor, and the R80 resistor provides access to the core voltage plane of the processor.

The CLKIN pin of the processor connects to a 24.576 MHz oscillator. The core frequency of the processor is derived by multiplying the frequency at the CLKIN pin by a value determined by the state of the processor pins, CLKCFG1 and CLKCFG0. The value at these pins is determined by the state of the SW10 switch (see [“Boot Mode and Clock Ratio Select Switch \(SW10\)” on page 2-12](#)). By default, the EZ-KIT Lite provides a core frequency of 147.456 MHz. It is possible to increase the speed of the processor by changing the value of the PMCTL register.

The SW10 switch also configures the boot mode of the processor. The EZ-KIT Lite is capable of parallel port boot and SPI master boot. By default, the EZ-KIT Lite boots from the parallel port. For information about configuring the boot modes, see [“Boot Mode and Clock Ratio Select Switch \(SW10\)” on page 2-12](#).

## Parallel Port

The parallel port (PP) of the ADSP-21364 processor consists of a 16-bit multiplex address/data memory bus (AD15-0) and an address latch-enable pin (ALE). The interface does not have any memory select pins; these signals must be generated by decoding the address.

The PP connections to the EZ-KIT Lite are shown in [Figure 2-2 on page 2-4](#). The PP connects to an 8-bit parallel flash memory, an 8-bit SRAM memory, and eight general-purpose LEDs. The upper three address bits connect to a 3-to-8 decoder, providing eight memory select pins. See [“External Memory” on page 1-12](#) for more information about accessing flash memory and SDRAM memory.

Because the PP is a multiplexed address/data memory bus, two 8-bit latches are used to latch the upper address bits. Additional latch is used to drive the LEDs. The latter allows the LED values to be written to as if they were at a memory location. For more information about using the LEDs, refer to the [“LEDs and Push Buttons” on page 1-14](#).

# System Architecture

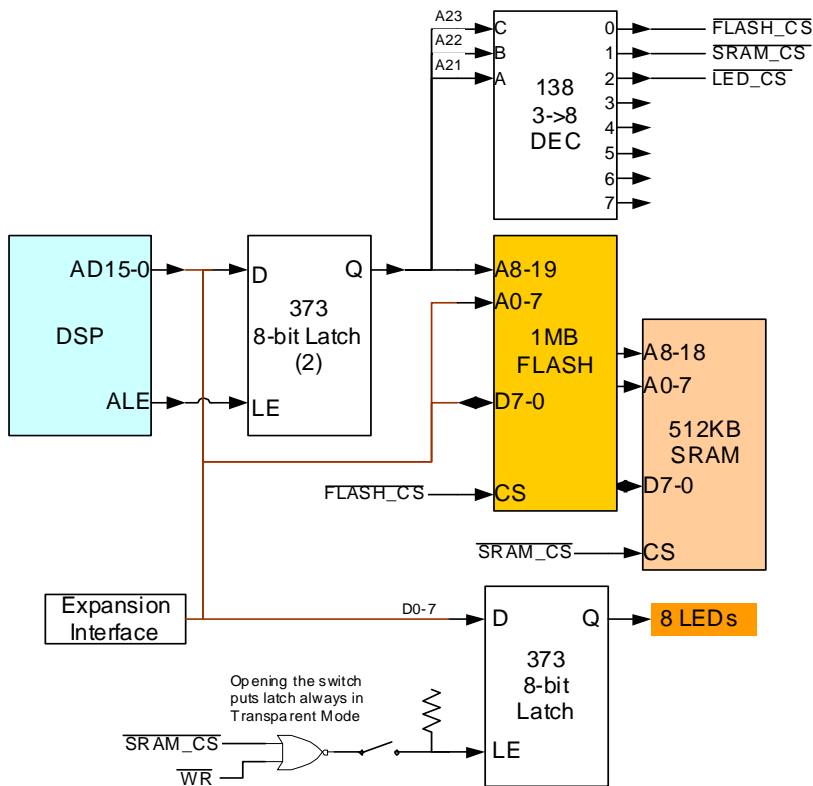

Figure 2-2. Parallel Port Connections Block Diagram

All of the PP signals are available externally via the expansion interface connectors (J1-3). The pinout of the connectors can be found in [“ADSP-21364 EZ-KIT Lite Schematic”](#) on page B-1.

## DAI Interface

The pins of the digital application interface (DAI) connect to the signal routing unit (SRU). The SRU is a flexible routing system, providing a large system of signal flows within the processor. In general, the SRU

allows to route the DAI pins to different internal peripherals in various combinations.

The DAI pins connect to the AD1835A audio codec, a 26-pin header, 2 RCA connectors, the audio oscillator output, and two push buttons.

Figure 2-3 illustrates the EZ-KIT Lite’s connections to the DAI.

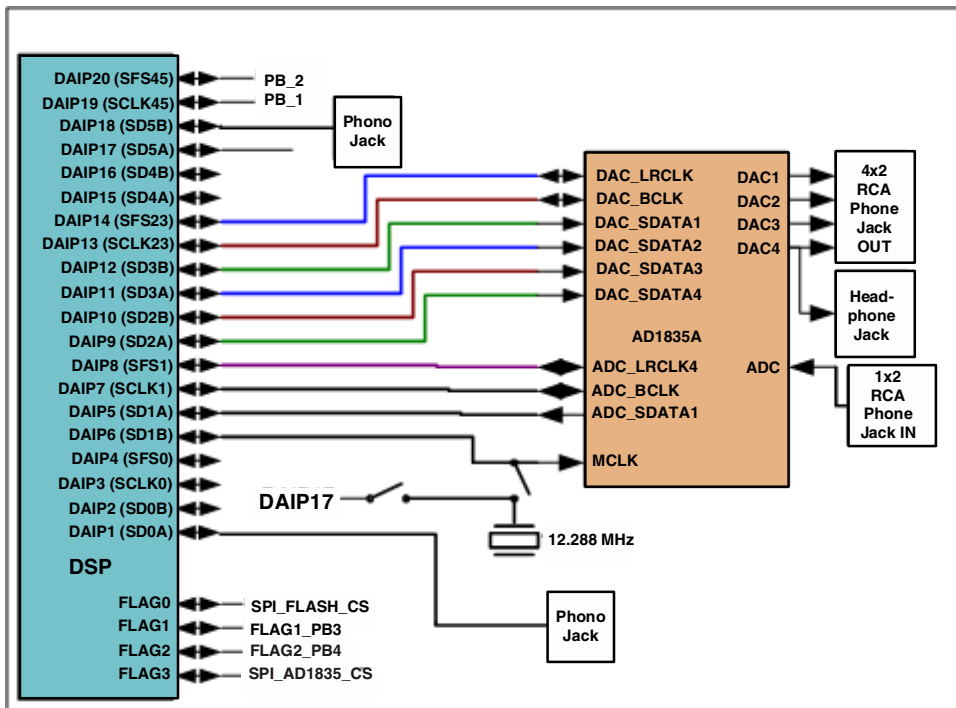

Figure 2-3. DAI Connections Block Diagram

To use the DAI for a different purpose, disable any signal driving the DAI pins, with a switch. See “[Codec Setup Switch \(SW7\)](#)” on page 2-10 for how to. In addition, the codec setup switch can route the output signal of the 12.288 MHz audio oscillator. By default, the signal is used as the master clock (MCLK) for the AD1835A codec.

## System Architecture

All of the DAI signals are available externally via the expansion interface connectors (J1-3), as well as the 0.1" spaced header P3. The pinout of the connectors can be found in [“ADSP-21364 EZ-KIT Lite Schematic” on page B-1](#).

## SPI Interface

The serial peripheral interface (SPI) of the processor connects to an SPI flash memory and the AD1835A audio codec. The FLAG0 pin is used as a memory select for the SPI flash memory, and the FLAG3 pin—for the AD1835A's configuration registers.

The SPI chip select lines for the SPI flash memory and the AD1835A audio codec connect to the processor via switch SW8 pins 1 and 3. The default for SW8 is all positions ON. The switch disables the SPI devices on the EZ-KIT Lite, enabling the same flag pins be driven on the expansion interface

All of the SPI signals are available externally via the expansion interface connectors (J1-3), as well as the 0.1" spaced header P2. The pinout of the connectors can be found in [“ADSP-21364 EZ-KIT Lite Schematic” on page B-1](#).

## FLAG Pins

The processor has four general-purpose IO FLAG pins. [Table 2-1](#) describes each flag connections.

For information on how to disable the push buttons from driving the corresponding processor flag pin, see [“Push Button Enable Switch \(SW9\)” on page 2-11](#).



Table 2-1. IO FLAG Pins

FLAG Pin	EZ-KIT Lite Function
FLAG0	SPI flash chip select
FLAG1	Push button (SW1) input
FLAG2	Push button (SW2) input
FLAG3	AD1835A's SPI interface chip select

The FLAG signals are available externally via the expansion interface connectors (J1-3). The pinout of the connectors can be found in [“ADSP-21364 EZ-KIT Lite Schematic”](#) on page B-1.

## Expansion Interface

The expansion interface consists of three 90-pin connectors. [Table 2-2](#) shows the interfaces each connector provides. For the exact pinout of the connectors, refer to [“ADSP-21364 EZ-KIT Lite Schematic”](#) on page B-1. The mechanical dimensions can be obtained from [Technical Support](#).

Table 2-2. Expansion Interface Connectors

Connector	Interfaces
J1	5V, AD15-0
J2	3.3V, FLAG3-0, DAI_P20-1, SPI
J3	5V, 3.3V, reset, parallel port control signals

Limits to the current and to the interface speed must be taken into consideration when using the expansion interface. The maximum current limit is dependent on the capabilities of the used regulator. Additional circuitry can also add extra loading to signals, decreasing their maximum effective speed.



Analog Devices does not support and is not responsible for the effects of additional circuitry.

### JTAG Emulation Port

The JTAG emulation port allows an emulator to access the internal and external memory of the processor through a 6-pin interface. The JTAG emulation port of the processor also connects to the USB debugging interface. When an emulator connects to the board at ZP4, the USB debugging interface is disabled. This is not the standard connection of the JTAG interface.

For information about the standard connection of the interface, see *EE-68* published on the Analog Devices Web site. For more information about the JTAG connector, see “[JTAG Header \(ZP4\)](#)” on page 2-21. To learn more about SHARC processor emulators, go to <http://www.analog.com/processors/tools/sharc>.

## Switch Settings

Figure 2-4 shows the location and default settings of the EZ-KIT Lite switches.

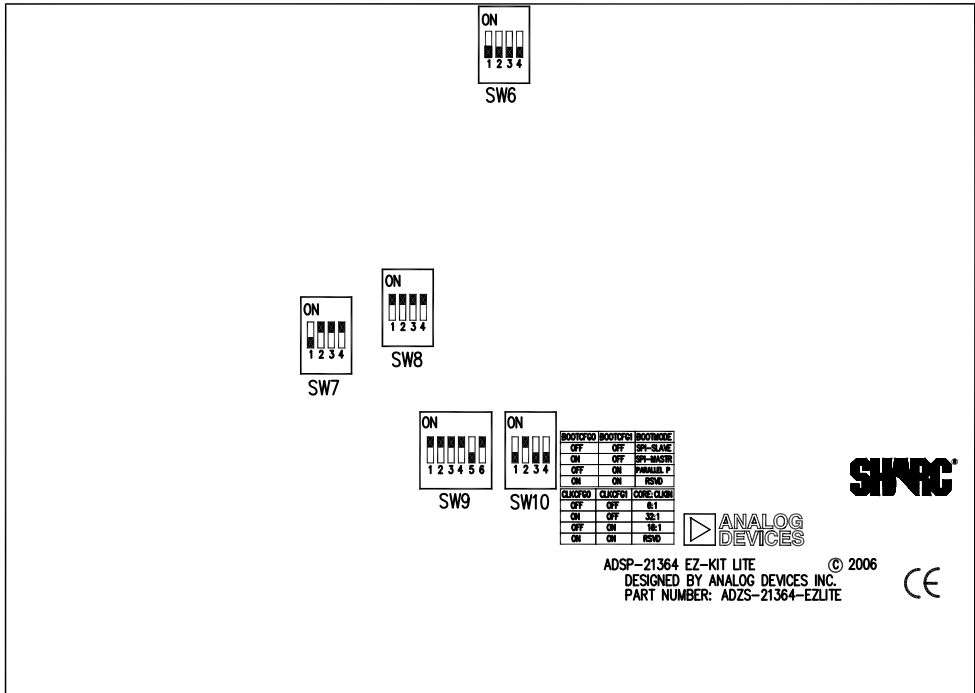

Figure 2-4. DIP Switch Locations and Default Settings

### Electret Microphone Select Switch (SW6)

To connect an electret microphone to the audio input, place all positions of the SW6 switch ON. The default position of this switch is all OFF. When all of the positions are ON, a DC offset of 2.5V is added to the signal, and gain of the input amplifiers is changed from 1x to 10x.

### Codec Setup Switch (SW7)

The codec setup switch (SW7) can re-route signals going to the AD1835A codec and can setup the communication protocol of the codec.

Positions 1 and 2 determine the clock routing for the audio oscillator to the codec and to the processor. [Figure 2-5](#) illustrates how the switch positions 1 and 2 connect on the board. In the default position, route the DAI\_P17 pin to DAIP6 (in software) to clock the AD1835A.

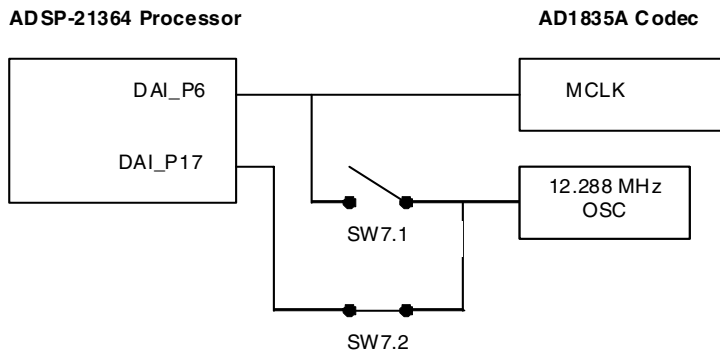

Figure 2-5. Audio Clock Routing

Position 3 of the SW7 switch determines if the AD1835A device is a master or is a slave. If the AD1835A is a master, the device's serial interface generates the frame sync and clock signals necessary to transfer data. When the device is a slave, the processor must generate the frame sync and clock signals. By default, position 3 is ON, and the AD1835A generates the control signals.

Position 4 of SW7 disconnects the AD1835A's ADC\_DATA pin from the DAI interface. This is useful when the DAI interface connects to another device.

## SPI Disable Switch (SW8)

The SPI interface switch (SW8) disables the SPI chip select lines connected to the SPI flash memory and the AD1835A audio codec. The switch also disables the `ADC_LRCLK` and `ADC_BCLK` signals on the AD1835A device. The switch allows a customer to re-use the same pins on the SPI interface and on the expansion interface. The SW8 default is all positions ON unless any of the switch signals or the SPI interface signals are used on the expansion connector or via an EZ-Extender<sup>®</sup>.

## Push Button Enable Switch (SW9)

The push button enable switch (SW9) disconnects the push buttons from the corresponding processor pins. This allows the signals to be used elsewhere on the board. [Table 2-3](#) shows the SW9 connections. By default, all of the switch positions are ON.

Table 2-3. Push Button Enable Switch (SW9) Connections

Switch Position	Push Button Reference Designator	Processor Pin
1	SW1	FLAG1
2	SW2	FLAG2
3	SW3	DAI_P19
4	SW4	DAI_P20

Position 6 of SW9 connects or disconnects the latch-enable pin of the LED to the logical OR of the `WE` and `LED_CS` signals. When position 6 is OFF, the latch-enable pin of the LED latch (U24) is pulled high, making the latch transparent. In this position, the value of the LEDs is directly connected to AD7-0.

## Switch Settings

When position 6 is ON, the values of the LEDs are set by writing to a memory location. The lower 8 bits of the data written to the address 0x1400 0000 set the values of the LEDs. By default, position 6 is ON. For more information refer to [“LEDs and Push Buttons” on page 1-14](#).

## Boot Mode and Clock Ratio Select Switch (SW10)

The SW10 switch sets the boot mode and clock multiplier ratio. [Table 2-4](#) shows how to set up the boot mode using SW10 positions 1 and 2. By default, the EZ-KIT Lite boots in parallel port mode from flash memory.

Table 2-4. Boot Mode Configuration (SW10)

BOOTCFG1 Pin (Position 2)	BOOTCFG0 Pin (Position 1)	Boot Mode
OFF	OFF	SPI slave boot
OFF	ON	SPI master boot
ON	OFF	Parallel flash boot (default)
ON	ON	Internal boot

[Table 2-5](#) shows how to set up the clock multiply ratio using SW10 positions 3 and 4. By default, the processor increases the clock multiply ratio by six, setting the core clock to 147.456 MHz.

Table 2-5. Core Clock Rate Configuration (SW10)

CLKCFG1 (Position 4)	CLKCFG0 (Position 3)	Core to CLKIN Ratio
OFF	OFF	6:1 (default)
OFF	ON	32:1
ON	OFF	16:1
ON	ON	NA

## Loop-Back Test Switch (SW11)

The loop-back test switch (SW11) is located at the bottom of the board. This switch is used for testing; all switch positions should remain OFF.

## LEDs and Push Buttons

This section describes functionality of the LEDs and push buttons. Figure 2-6 shows the LED and push button locations.

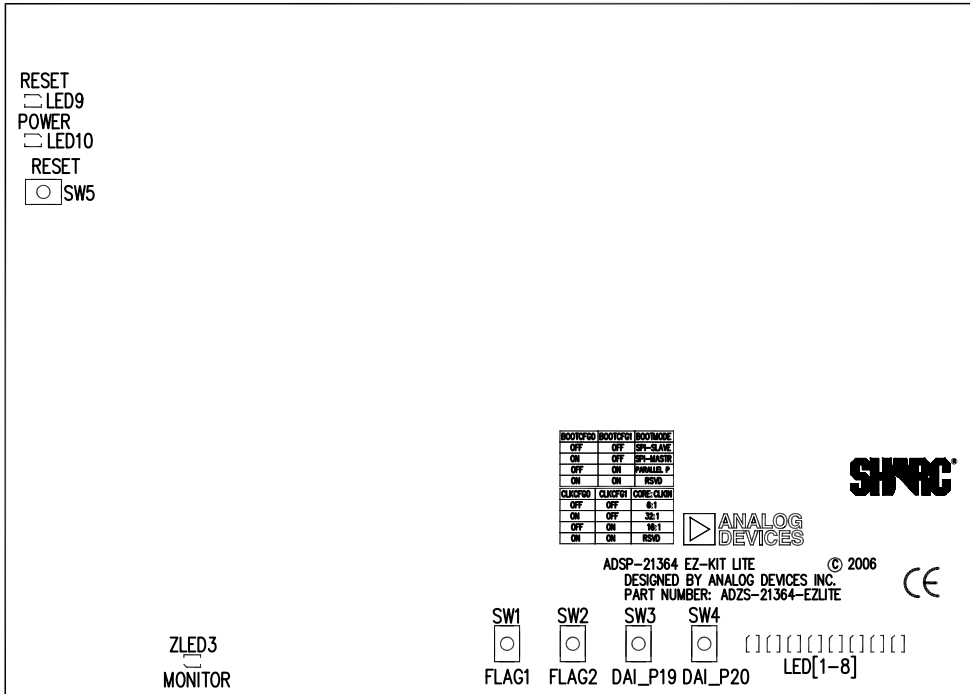

Figure 2-6. LED and Push Button Locations

### General Purpose LEDs (LED8–1)

Eight general-purpose LEDs connect to the processor through a latch on signals AD7–0. The LEDs can be accessed by writing to the FLAG registers or by writing to a memory address. Refer to [“LEDs and Push Buttons” on page 1-14](#) for more information.

### Reset LED (LED9)

When LED9 is lit (red), a master reset of all the major ICs is active.

### Power LED (LED10)

When LED10 is lit (green), it indicates that power is being supplied to the board properly.

### USB Monitor LED (ZLED3)

The USB monitor LED (ZLED3) indicates that USB communication has been initialized successfully, and you can connect to the processor using an EZ-KIT Lite session. Once the USB cable is plugged into the board, it takes approximately 15 seconds for the USB monitor LED to light. If the LED does not light, try cycling power on the board and/or reinstalling the USB driver.



When the development software is actively communicating with the EZ-KIT Lite target board, the LED can flicker, indicating communications handshake.



## Push Buttons (SW1–4)

Four push buttons (SW1-4) are provided for general-purpose user input. Two push buttons connect to the FLAG pins of the processor. The other two connect to the DAI of the processor. The push buttons are active high and, when pressed, send a high (1) to the processor. Refer to [“LEDs and Push Buttons” on page 1-14](#) for more information. The push button enable switch (SW9) is capable of disconnecting the push buttons from the corresponding processor pins (refer to [“Push Button Enable Switch \(SW9\)” on page 2-11](#) for more information).

The processor signals and corresponding push buttons are summarized in [Table 2-6](#).

Table 2-6. Push Button Connections

Processor Signal	Push Button Reference Designator	Processor Signal	Push Button Reference Designator
FLAG1	SW1	DAI_P19	SW3
FLAG2	SW2	DAI_P20	SW4

## Board Reset Push Button (SW5)

The RESET push button (SW5) resets all of the ICs on the board.

# Connectors

This section describes the connector functionality and provides information about mating connectors. [Figure 2-7](#) shows the connector locations.

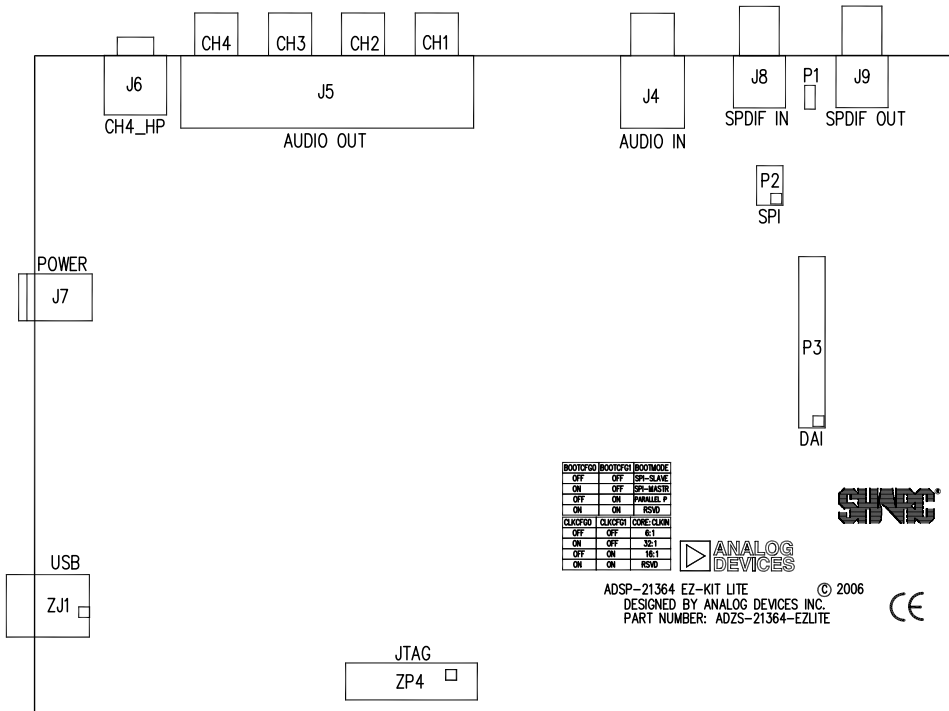

Figure 2-7. Connector Locations

## Expansion Interface (J1–J3)

Three board-to-board connectors (J1-3) provide signals for most of the processor’s peripheral interfaces. The connectors are located at the bottom of the board. For more information about the interface, see [“Expansion Interface” on page 2-7](#). For the connectors availability and pricing, contact Samtec.

Part Description	Manufacturer	Part Number
90-position 0.05” spacing,SMT	SAMTEC	SFC-145-T2-F-D-A
<b>Mating Connectors</b>		
90-position 0.05” spacing (through hole)	SAMTEC	TFM-145-x1 series
90-position 0.05” spacing (surface mount)	SAMTEC	TFM-145-x2 series
90-position 0.05” spacing (low cost)	SAMTEC	TFC-145 series

## Audio In RCA Connector (J4)

Part Description	Manufacturer	Part Number
Two-channel right angle RCA jack	SWITCHCRAFT	PJRS1X2S02X
<b>Mating Cable</b>		
Two-channel RCA interconnect cable	MONSTER CABLE	BI100-1M

## Connectors

### Audio Out RCA Connector (J5)

Part Description	Manufacturer	Part Number
Six-channel right angle RCA jack	SWITCHCRAFT	PJRS4X2U01X
<b>Mating Cable</b>		
Two-channel RCA interconnect cable	MONSTER CABLE	BI100-1M

### Headphone Out Jack (J6)

Part Description	Manufacturer	Part Number
3.5 mm stereo jack	A/D ELECTRONICS	ST-323-5

### Power Jack (J7)

The power connector (J7) provides all of the power necessary to operate the EZ-KIT Lite board.

Part Description	Manufacturer	Part Number
2.5 mm power jack	SWITCHCRAFT DIGI-KEY	RAPC712X RAPC712X-ND
<b>Mating Power Supply (shipped with EZ-KIT Lite)</b>		
7V power supply	CUI STACK	DMS070214-P6P-SZ

The power connector supplies DC power to the EZ-KIT Lite board. [Table 2-7](#) shows the power supply specifications.

Table 2-7. Power Supply Specifications

Terminal	Connection
Center pin	+7 VDC@2.14A
Outer ring	GND

## S/PDIF Coax Connectors (J8 and J9)

Part Description	Manufacturer	Part Number
Coaxial	SWITCHCRAFT	PJРАН1X1U01X
<b>Mating Cable</b>		
Two-channel RCA interconnect cable	MONSTER CABLE	BI100-1M

## SPI Header (P2)

The SPI connector (P2) provides access to all of the SPI signals in the form of a .1” spacing header. In addition, the FLAG1 signal can be used as a chip select. If you are using FLAG1 as a chip select, disable the push button associated with the flag. For more information, see [“Push Button Enable Switch \(SW9\)”](#) on page 2-11.

Part Description	Manufacturer	Part Number
6-pin IDC header	SULLINS	GEC03DAAN

## Connectors

### DAI Header (P3)

The DAI connector (P3) provides access to all of the DAI signals in the form of a .1" spacing header. When using the header to access the DAI pins of the processor, ensure that signals, which normally drive the DAI pins, are disabled. Refer to [“Codec Setup Switch \(SW7\)” on page 2-10](#) for more information on how to disable signals already being driven from elsewhere on the EZ-KIT Lite.

Part Description	Manufacturer	Part Number
26-PIN IDC HEADER	BERG	54102-T08-13LF



### USB Connector (ZJ1)

The USB connector (ZJ1) allows to configure and program the processor.

Part Description	Manufacturer	Part Number
Type B USB receptacle	MILL-MAX DIGI-KEY	897-30-004-90-000 ED90064-ND

## JTAG Header (ZP4)

The JTAG header (ZP4) is the connecting point for a JTAG in-circuit emulator pod. When an emulator connects to the JTAG header, the USB debug interface is disabled.

-  Pin 3 is missing to provide keying. Pin 3 in the mating connector should have a plug.
-  When using an emulator with the EZ-KIT Lite board, follow the connection instructions provided with the emulator.

Part Description	Manufacturer	Part Number
14-pin IDC header (ZP4)	FCI	68737-414HLF

## Connectors



# A ADSP-21364 EZ-KIT LITE BILL OF MATERIALS

The bill of materials corresponds to “[ADSP-21364 EZ-KIT Lite Schematic](#)” on page B-1.

Ref.	Qty.	Description	Reference Designator	Manufacturer	Part Number
1	1	74LVC14A SOIC14	U33	TI	74LVC14AD
2	1	24.576MHZ OSC001	U16	EPSON	SG-8002DC 24.5760M-PCCL3:
3	1	SN74AHC1G02 SOT23-5	U26	TI	SN74AHC1G02DBVRE4
4	1	12.288MHZ OSC003	U17	DIGI-KEY	SG-8002CA-PCC-ND (12.288M)
5	1	74LVC138AD SOIC16	U25	TI	SN74LVC138AD
6	3	74LVC373APW TSSOP20	U18,U21,U24	TI	SN74LVC373APWRE4
7	1	IS61LV5128AL TSOP44	U15	ISSI	IS61LV5128AL-10TLI
8	1	LTC1877MSOP8	VR5	LINEAR TECH	LTC1877EMS8#PBF
9	1	74LVCU04AD SOIC14	U3	DIGI-KEY	296-9861-1-ND
10	1	FDC658P SOT23-6	U13	FAIRCHILD	FDC658P
11	1	21364 M25P20 "U12"	U12	STMICRO	M25P20-VMN6TP

Ref.	Qty.	Description	Reference Designator	Manufacturer	Part Number
12	1	21364 AM29LV081B "U19"	U19	AMD	AM29LV081-120ED
13	1	ADM708SARZ SOIC8	U22	ANALOG DEVICES	ADM708SARZ
14	1	AD8532ARZ SOIC8	U10	ANALOG DEVICES	AD8532ARZ
15	2	ADP3336ARMZ MSOP8	VR1,VR4	ANALOG DEVICES	ADP3336ARMZ-REEL
16	8	AD8606ARZ SOIC8	U2,U4-9,U11	ANALOG DEVICES	AD8606ARZ
17	1	AD1835AASZ MQFP52	U14	ANALOG DEVICES	AD1835AASZ
18	1	ADSP-21364 BGA136	U1	ANALOG DEVICES	ADSP-21364KBCZ-1AA
19	1	ADP1864 SOT23-6	VR2	ANALOG DEVICES	ADP1864AUJZ-R7
20	5	RUBBERFOOT	M1-5	MOUSER	517-SJ-5018BK
21	1	PWR 2.5MM_JACK CON005	J7	SWITCH- CRAFT	RAPC712X
22	1	RCA 4X2 CON011	J5	SWITCH- CRAFT	PJRS4X2U01X
23	2	RCA 1X1 CON012	J8-9	SWITCH- CRAFT	PJRN1X1U01X
24	5	MOMENTARY SWT013	SW1-5	PANASONIC	EVQ-PAD04M
25	3	.05 45X2 CON019	J1-3	SAMTEC	SFC-145-T2-F-D-A
26	1	DIP8SWT016	SW11	C&K	TDA08H0SB1
27	1	DIP6SWT017	SW9	CTS	218-6LPST

## ADSP-21364 EZ-KIT Lite Bill of Materials

Ref.	Qty.	Description	Reference Designator	Manufacturer	Part Number
28	4	DIP4SWT018	SW6-8,SW10	ITT	TDA04HOSB1
29	1	RCA RCA_1X2 CON031	J4	SWITCH- CRAFT	PJRAS1X2S02X
30	1	IDC 2X1 IDC2X1	P1	FCI	90726-402HLF
31	1	IDC 7X2 IDC7X2	ZP4	FCI	68737-414HLF
32	1	2.5A RESE- TABLE FUS001	F1	RAYCHEM	SMD250F-2
33	1	3.5MM STEREO_JACK CON001	J6	A/D ELEC- TRONICS	ST-323-5
34	1	IDC 13x2 IDC13x2	P3	BERG	54102-T08-13LF
35	1	IDC 3X2 IDC3X2	P2	SULLINS	GEC03DAAN
36	1	01/4W5%1206	R82	KOA	0.0ECTrk7372BTED
37	8	YELLOW LED001	LED1-8	PANASONIC	LN1461C
38	8	330PF 50V 5% 0805	C104,C106,C108, C110,C112,C114, C116,C118	AVX	08055A331JAT
39	13	0.01UF 100V 10% 0805	C1,C22,C127,C153, C155,C157-158, C160-164,C182	AVX	08051C103KAT2A
40	8	0.22UF 25V 10% 0805	C77,C87,C99-102, C111,C131	AVX	08053C224FAT
41	11	0.1UF 50V 10% 0805	C21,C45,C47, C120-121,C132-133, C141,C148,C152, C156	AVX	08055C104KAT
42	4	1000PF 50V 5% 0805	C82-83,C88,C98	AVX	08055A102JAT2A

Ref.	Qty.	Description	Reference Designator	Manufacturer	Part Number
43	21	10K 1/10W 5% 0805	R17,R64,R66,R70, R74,R76,R78,R92, R96,R98,R152, R159-164,R171-174	VISHAY	CRCW080510K0JNEA
44	2	33 1/10W 5% 0805	R68,R81	VISHAY	CRCW080533R0JNEA
45	2	4.7K 1/10W 5% 0805	R72,R176	VISHAY	CRCW08054K70JNEA
46	2	2.0K 1/8W 1% 1206	R3,R5	VISHAY	CRCW12062K00FKEA
47	10	49.9K 1/8W 1% 1206	R114-115,R117-124	VISHAY	CRCW120649K9FKEA
48	12	100PF 100V 5% 1206	C2-12,C64	AVX	12061A101JAT2A
49	1	2.2UF 35V 10% B	CT21	AVX	TAJB225K035R
50	2	10UF16V10%B	CT13-14	AVX	TAJB106K016R
51	4	100 1/10W 5% 0805	R185-188	VISHAY	CRCW0805100RJNEA
52	2	301.0 1/4W 1% 1206	R1-2	VISHAY	CRCW1206301RFKEA
53	9	220PF 50V 10% 1206	C90-97,C183	AVX	12061A221JAT2A
54	1	2A S2A DO-214AA	D2	MICRO COMM	S2A-TP
55	5	600 100MHZ 500MA 1206	FER2,FER5-8	STEWART	HZ1206B601R-10
56	1	100 1/8W 5% 1206	R8	PANASONIC	ERJ-8GEYJ101V
57	4	237.0 1/8W 1% 1206	R13-14,R18,R20	VISHAY	CRCW1206237RFKEA

## ADSP-21364 EZ-KIT Lite Bill of Materials

Ref.	Qty.	Description	Reference Designator	Manufacturer	Part Number
58	2	750.0K 1/8W 1% 1206	R11,R116	VISHAY	CRCW1206750KFKEA
59	4	5.76K 1/8W 1% 1206	R6,R10,R19,R22	VISHAY	CRCW12065K76FKEA
60	10	11.0K 1/8W 1% 1206	R47,R49-50,R52-53, R55-56,R58,R113, R136	VISHAY	CRCW120611K0FKEA
61	5	1UF 16V 10% 0805	C39,C44,C48,C56, C61	PANASONIC	ECJ2FB1E105K
62	1	75 1/8W 5% 1206	R4	VISHAY	CRCW120675R0JNEA
63	1	30PF 100V 5% 1206	C55	AVX	12061A300JAT2A
64	1	10 1/10W 5% 0805	R150	VISHAY	CRCW080510R0FKEA
65	1	249.0K 1/10W 1% 0805	R83	VISHAY	CRCW0805249KFKEA
66	12	680PF 50V 1% 0805	C76,C80-81,C89, C103,C105,C107, C109,C113,C115, C117,C119	AVX	08055A681FAT2A
67	2	10UF 25V +80-20% 1210	C46,C49	PANASONIC	ECJ4YF1E106Z
68	8	2.74K 1/8W 1% 1206	R140-147	VISHAY	CRCW12062K74FKEA
69	20	5.49K 1/8W 1% 1206	R7,R15-16,R21,R25, R28,R31,R34,R37, R40,R43,R46,R48, R51,R54,R57, R59-62	VISHAY	CRCW12065K49FKEA
70	8	1.65K 1/8W 1% 1206	R23,R26,R29,R32, R35,R38,R41,R44	VISHAY	CRCW12061K65FKEA

Ref.	Qty.	Description	Reference Designator	Manufacturer	Part Number
71	10	10UF 16V 20% CAP002	CT1-9,CT12	PANASONIC	EEE1CA100SR
72	2	68UF 25V 20% CAP003	CT10-11	PANASONIC	EEE-FC1E680P
73	1	2A SL22 DO-214AA	D1	DIGI-KEY	SL22-E3/1GI-ND
74	1	10UH 20% IND001	L1	TDK	445-2014-1-ND
75	10	0 1/10W 5% 0805	R9,R12,R73,R79-80, R90,R126,R151, R191-192	VISHAY	CRCW08050000Z0EA
76	1	190 100MHZ 5A FER002	FER3	MURATA	DLW5BSN191SQ2
77	1	470K 1/10W 5% 0805	R86	VISHAY	CRCW0805470KJNEA
78	8	3.32K 1/10W 1% 0805	R24,R27,R30,R33, R36,R39,R42,R45	PANASONIC	ERJ-6ENF3321V
79	4	1.2K 1/10W 5% 0805	R155-158	VISHAY	CRCW08051K20JNEA
80	6	10UF 6.3V 10% 0805	C26,C40,C50,C52, C84,C145	AVX	080560106KAT2A
81	3	6.04K 1/10W 1% 0805	R65,R148-149	DIGI-KEY	311-6.04KCRCT-ND
82	7	0.1UF 10V 10% 0402	C41,C128-129, C136,C140,C142, C144	AVX	0402ZD104KAT2A
83	5	0.01UF 16V 10% 0402	C134,C138,C147, C149,C151	AVX	0402YC103KAT2A
84	1	47UF16V10%D	CT19	DIGI-KEY	478-1788-2-ND
85	8	1000PF 50V 5% 0402	C130,C135,C137, C139,C143,C146, C150,C154	AVX	04025C102JAT2A

## ADSP-21364 EZ-KIT Lite Bill of Materials

Ref.	Qty.	Description	Reference Designator	Manufacturer	Part Number
86	2	64.9K 1/10W 1% 0805	R67,R87	VISHAY	CRCW080564K9FKEA
87	2	210.0K 1/4W 1% 0805	R69,R88	VISHAY	CRCW0805210KFKEA
88	1	1A SK12 DO-214AA	D3	DIODES INC	B120B-13-F
89	1	107.0 1/10W 1% 0805	R112	DIGI-KEY	311-107CRTR-ND
90	1	249.0 1/10W 1% 0805	R63	DIGI-KEY	311-249CRTR-ND
91	1	68PF 50V 5% 0603	C16	AVX	06035A680JAT2A
92	1	470PF 50V 5% 0603	C15	AVX	06033A471JAT2A
93	1	0 1/10W 5% 0603	R85	PHYCOMP	232270296001L
94	1	24.9K 1/10W 1% 0603	R84	DIGI-KEY	311-24.9KHTR-ND
95	1	47UF 6.3V 10% B	CT20	PANASONIC	EEE0JA470WR
96	1	0.05 1/2W 1% 1206	R89	SUSUMA	RL16326-R051-F-N
97	1	10UF 16V 10% 1210	C17	AVX	1210YD106KAT2A
98	1	GREENLED001	LED10	PANASONIC	LN1361CTR
99	1	REDLED001	LED9	PANASONIC	LN1261CTR
100	2	1000PF 50V 5% 1206	C37-38	AVX	12065A102JAT2A
101	8	2200PF 50V 5% 1206	C67-74	AVX	12065A222JAT050

Ref.	Qty.	Description	Reference Designator	Manufacturer	Part Number
102	1	100K 1/8W 5% 1206	R125	VISHAY	CRCW1206100KFKEA
103	10	270 1/8W 5% 1206	R138-139,R177-184	VISHAY	CRCW1206270RJNEA
104	8	604.0 1/8W 1% 1206	R127-134	PANASONIC	ERJ-8ENF6040V
105	4	1UF 20V 20%A	CT15-18	AVX	TAJA105K020R
106	1	255.0K 1/10W 1% 0603	R93	VISHAY	CRCW06032553FK
107	1	80.6K 1/10W 1% 0603	R91	DIGI-KEY	311-80.6KHRCT-ND
108	1	6.8UH 25% IND009	L2	DIGI-KEY	308-1328-1-ND



A

B

C

D

1

1

2

2

3

3

4

4

# ADSP-21364 EZ-KIT Lite Schematic

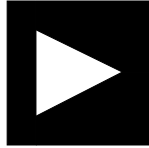
		<b>ANALOG DEVICES</b>		20 Cotton Road Nashua, NH 03063 PH: 1-800-ANALOGD	
<b>Title</b>		ADSP-21364 EZ-KIT Lite TITLE			
<b>Size</b> C	<b>Board No.</b>	A0190-2004		<b>Rev</b>	2.0A
<b>Date</b>	5-18-2007_15:33		<b>Sheet</b>	1	<b>of</b> 11

A

B

C

D

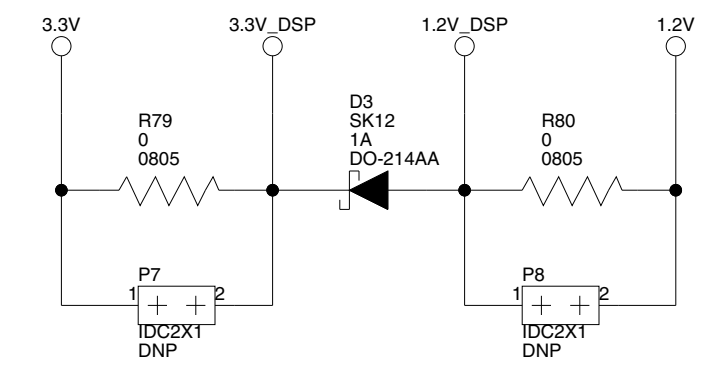
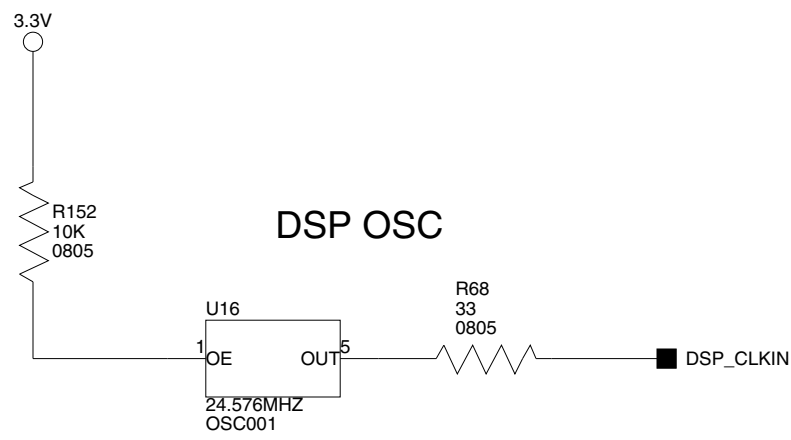

When designing your JTAG interface please refer to the Engineer to Engineer Note EE-68 which can be found at <http://www.analog.com>

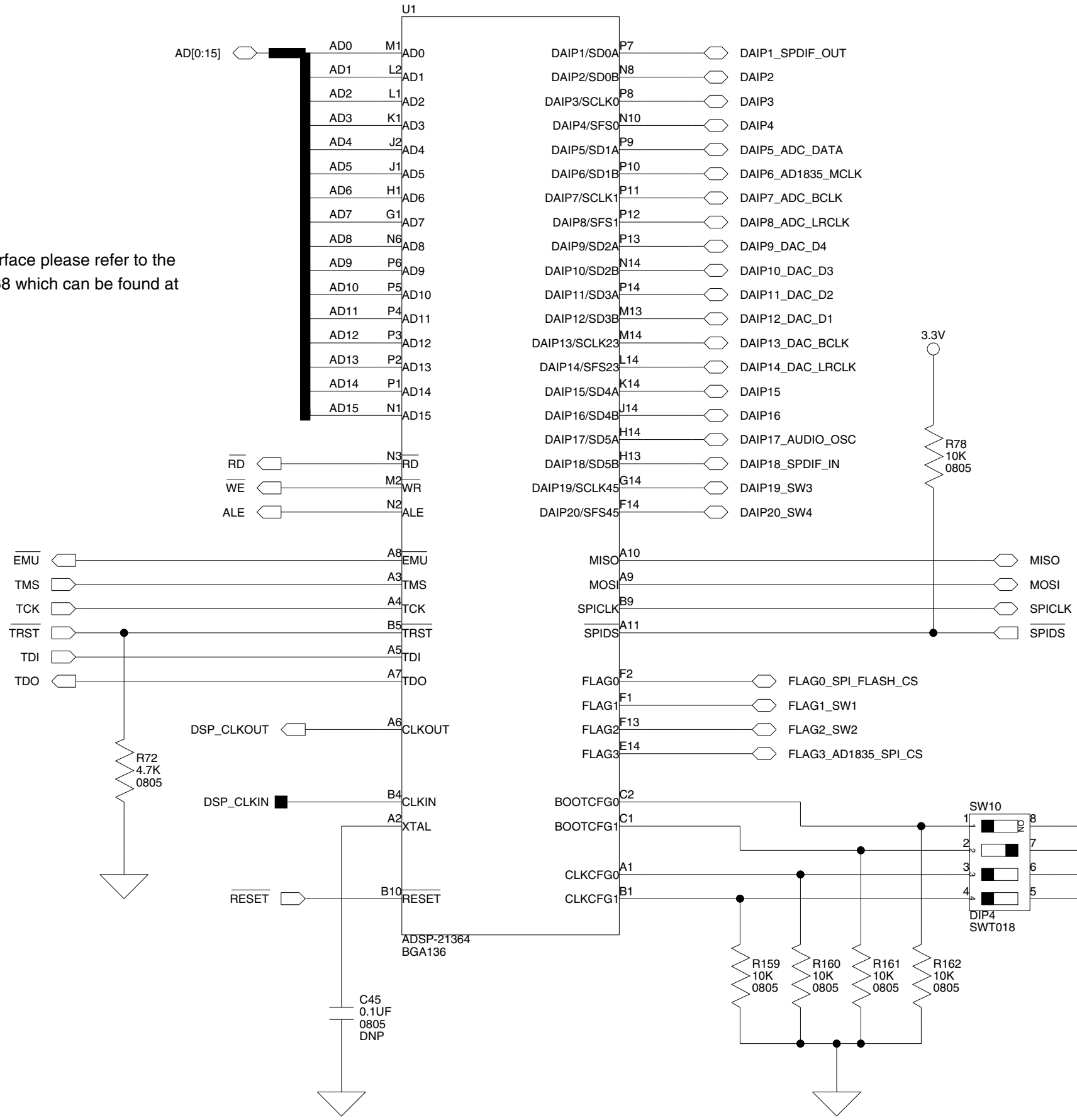

SW10: BOOT/CLOCK RATIO SELECT  
(Default: 1=OFF, 2=ON, 3=OFF, 4=OFF)

1	2	BOOTMODE
BOOTCFG0 OFF	BOOTCFG1 OFF	SPI SLAVE BOOT
BOOTCFG0 ON	BOOTCFG1 OFF	SPI MASTER BOOT
BOOTCFG0 OFF	BOOTCFG1 ON	PARALLEL PORT BOOT
BOOTCFG0 ON	BOOTCFG1 ON	RESERVED
3	4	CLOCK RATIO
CLKCFG0 OFF	CLKCFG1 OFF	CORE:CLKIN 6:1
CLKCFG0 ON	CLKCFG1 OFF	32:1
CLKCFG0 OFF	CLKCFG1 ON	16:1
CLKCFG0 ON	CLKCFG1 ON	RESERVED

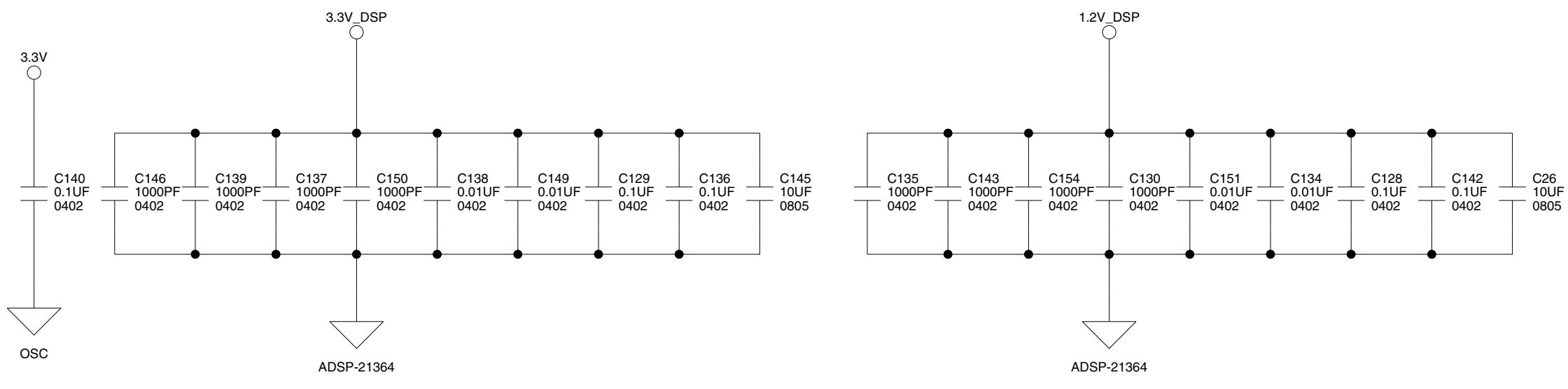
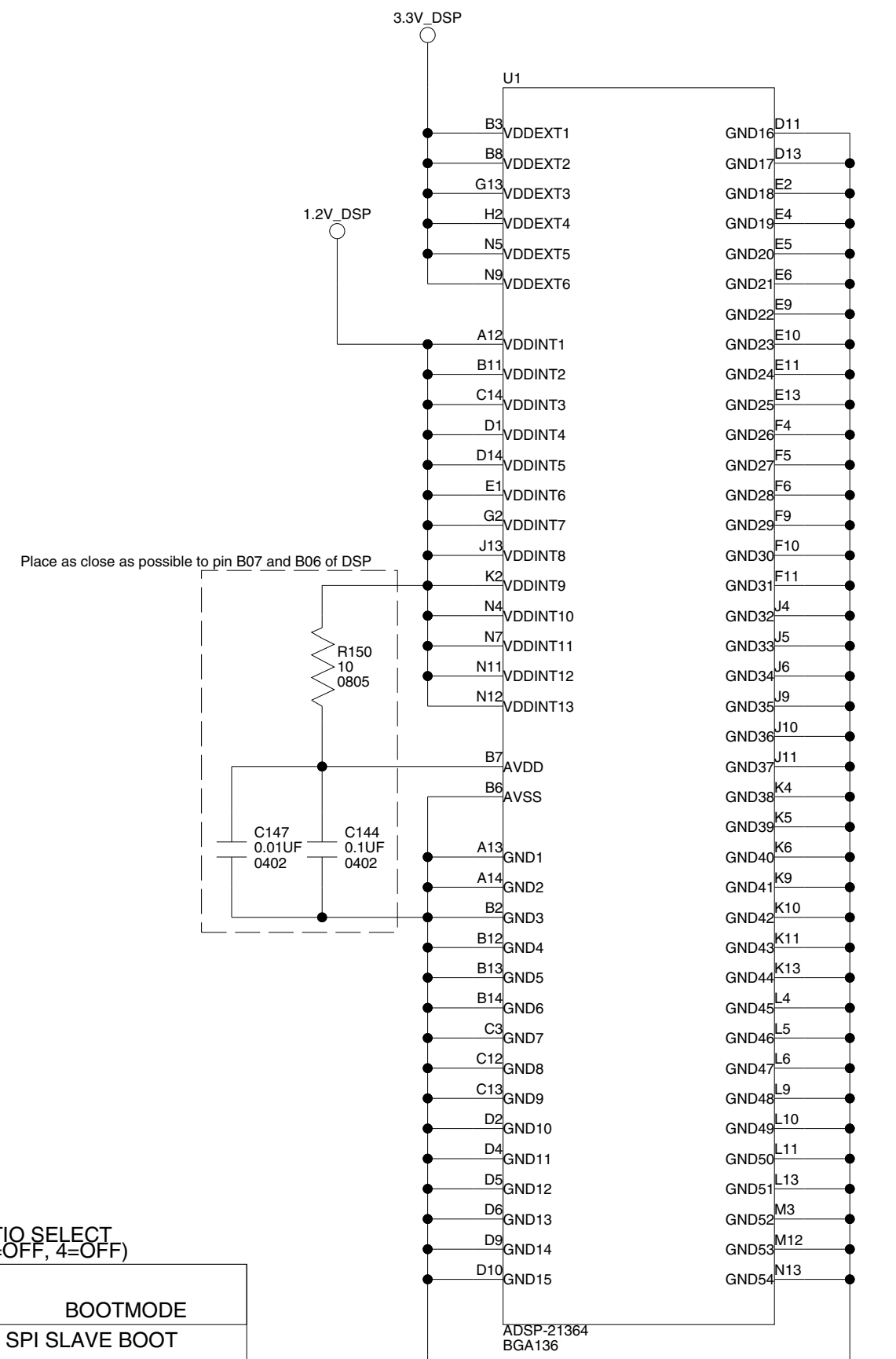

**ANALOG DEVICES**

20 Cotton Road  
Nashua, NH 03063  
PH: 1-800-ANALOGD

Title			<b>ADSP-21364 EZ-KIT Lite DSP</b>		
Size C	Board No.	A0190-2004			Rev
Date	5-18-2007_15:33	Sheet 2 of 11			2.0A

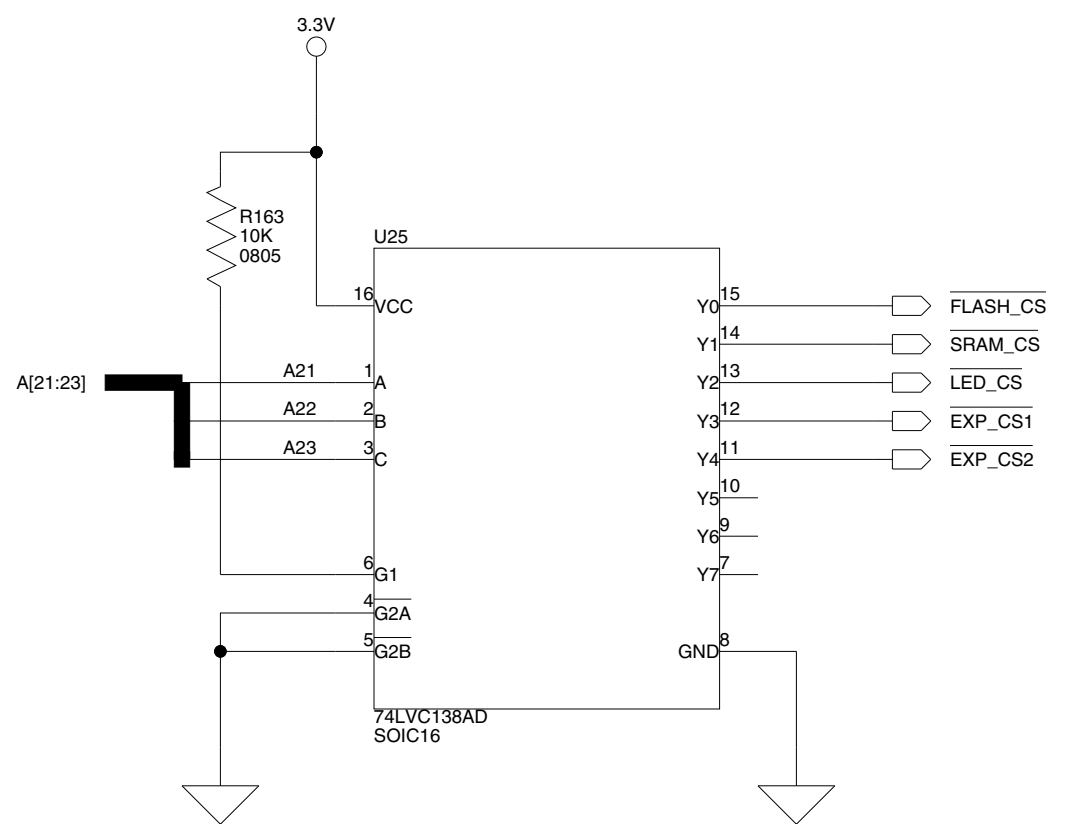

VALID DSP ADDRESS		BANK END ADDRESS	A23	A22	A21	BANK	DEVICE
1A0 0000	X	1FF FFFF	1	-	-	-	NONE
180 0000	X	19F FFFF	1	0	0	Y4	EXPANSION INTERFACE CS 2
160 0000	X	17F FFFF	0	1	1	Y3	EXPANSION INTERFACE CS 1
140 0000		15F FFFF	0	1	0	Y2	LEDs
120 0000		13F FFFF	0	0	1	Y1	SRAM
100 0000		11F FFFF	0	0	0	Y0	FLASH

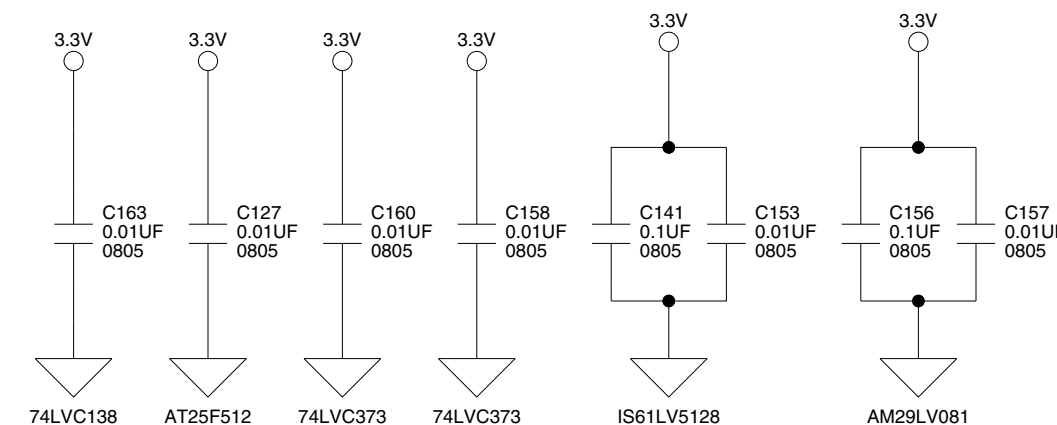
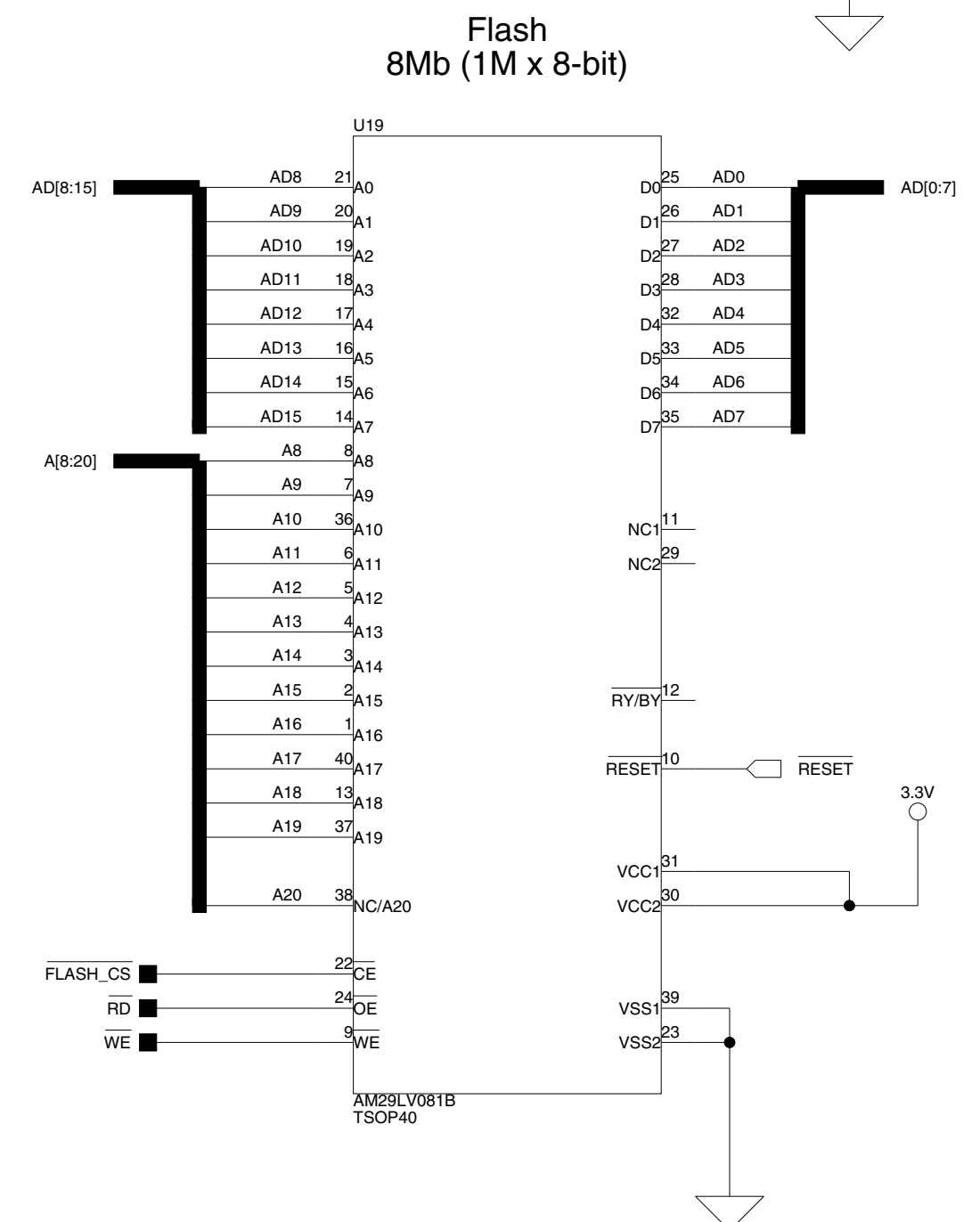
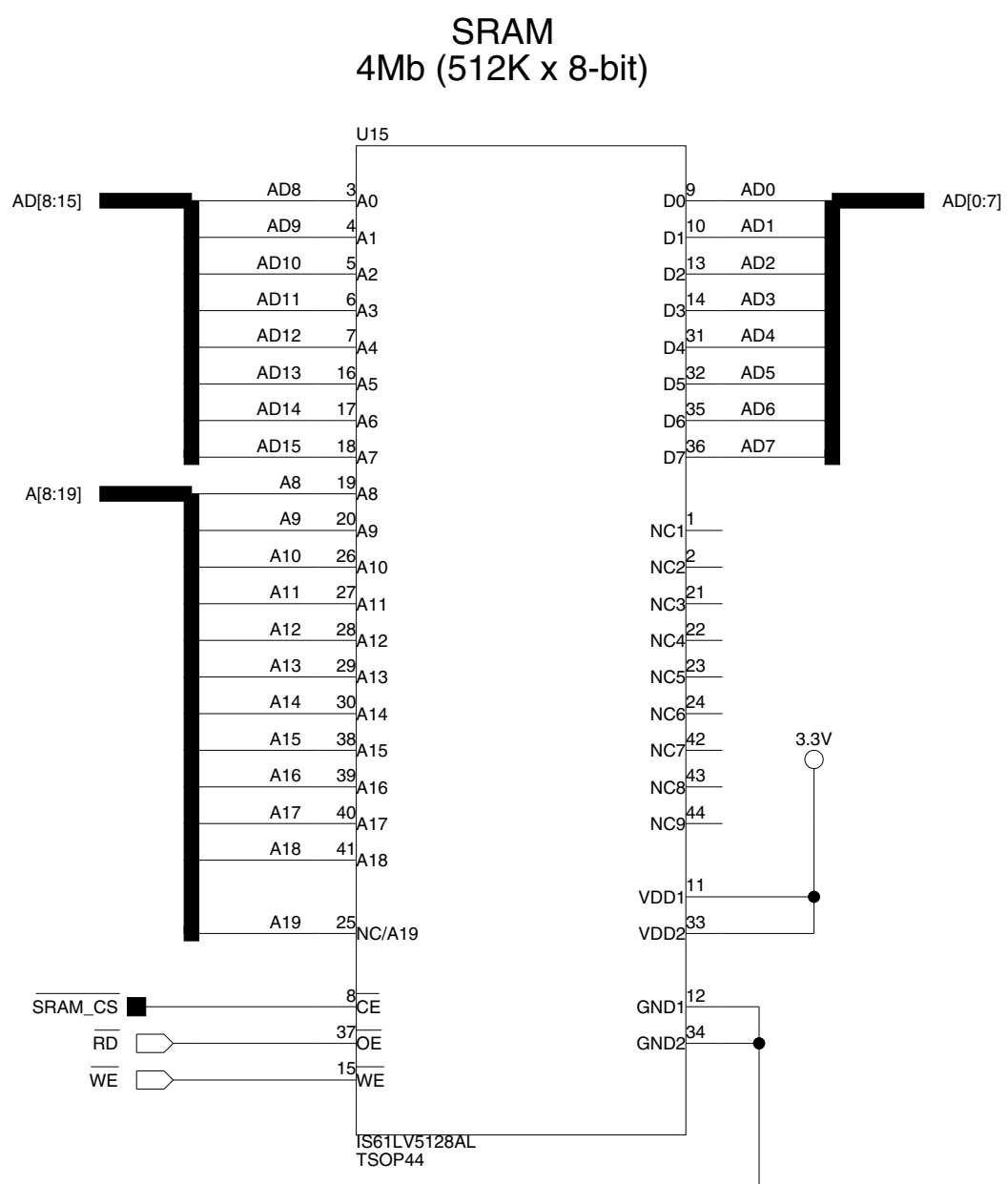
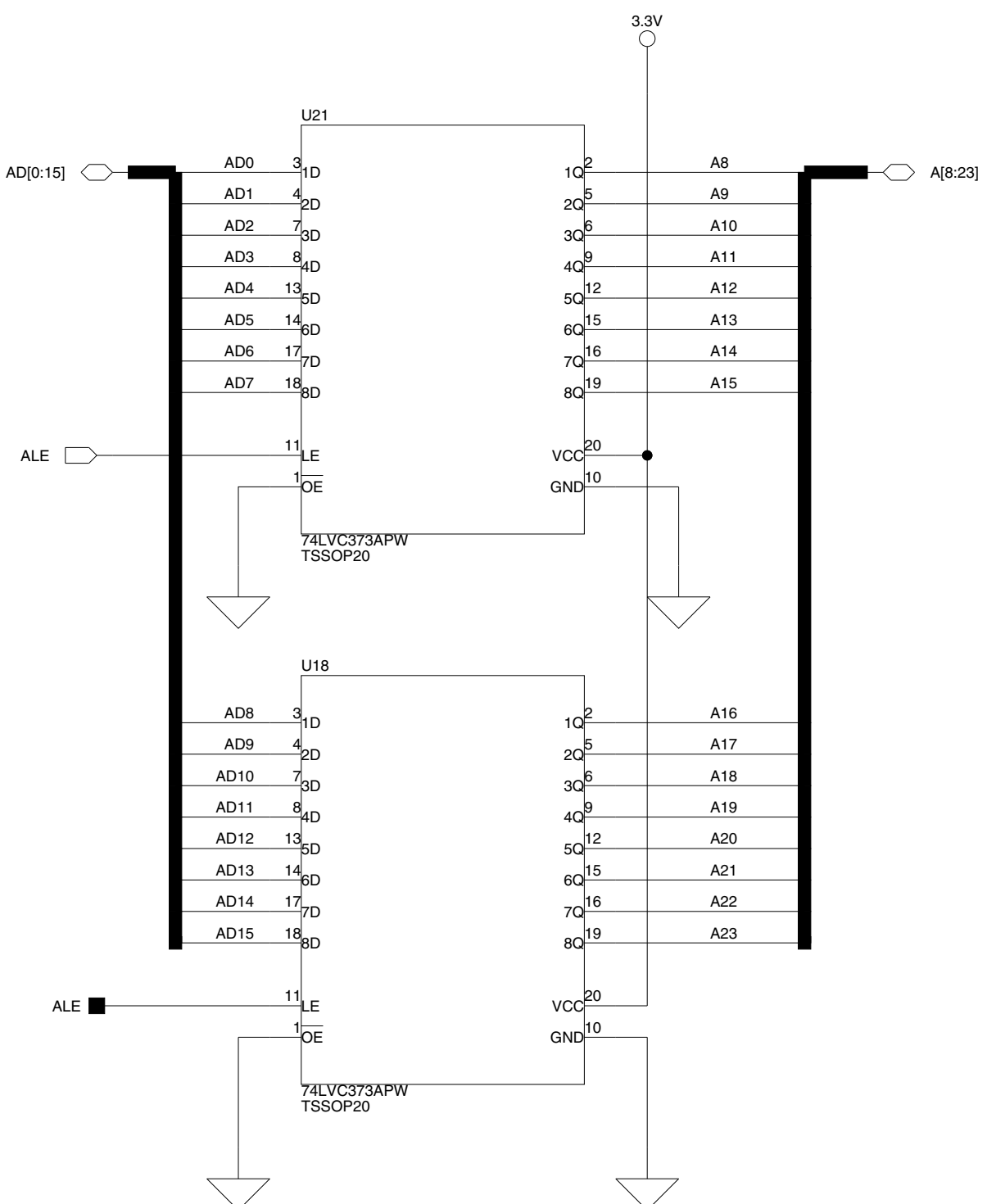
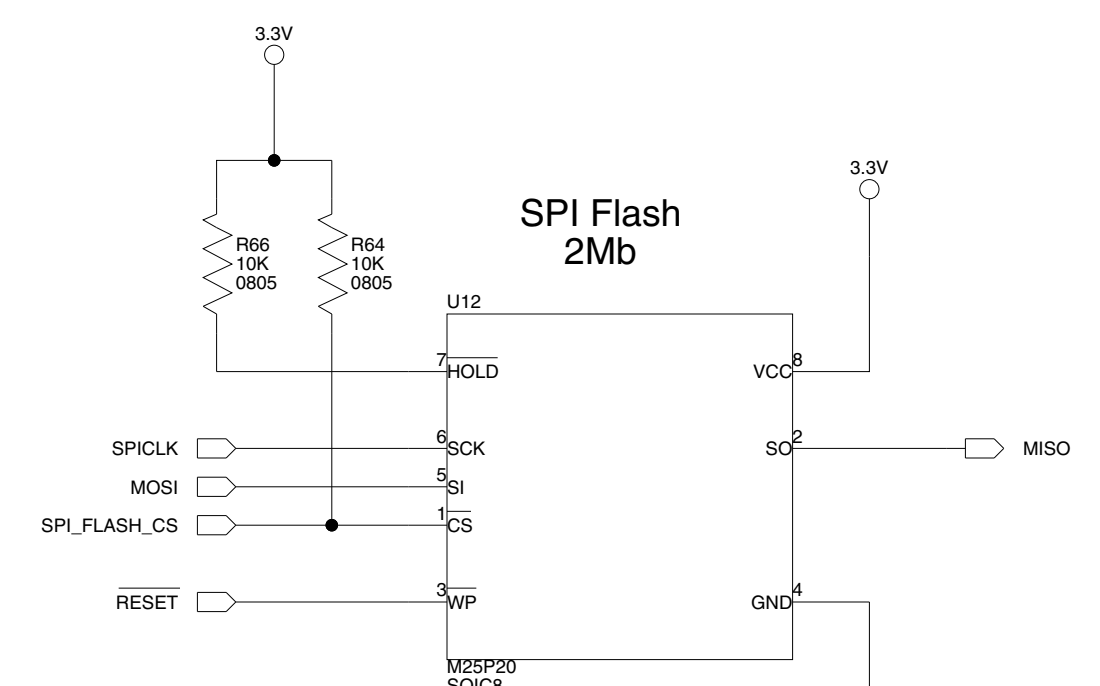

**ANALOG DEVICES**

20 Cotton Road  
Nashua, NH 03063  
PH: 1-800-ANALOGD

---

**Title** ADSP-21364 EZ-KIT Lite  
**MEMORY**

<b>Size C</b>	<b>Board No.</b> A0190-2004	<b>Rev</b> 2.0A
<b>Date</b> 5-18-2007_15:33	<b>Sheet</b> 3 of 12	

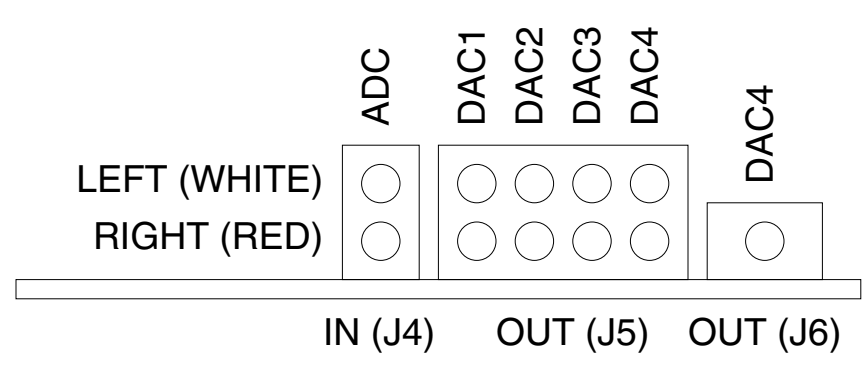

**AD1835 AUDIO CODEC**

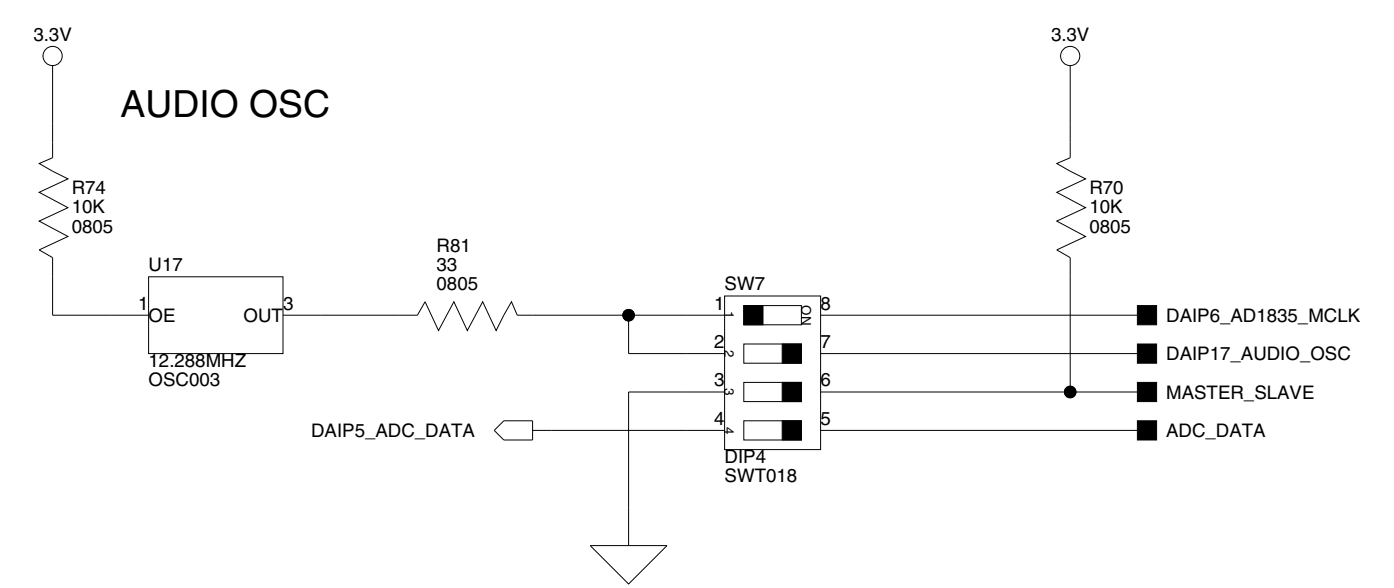
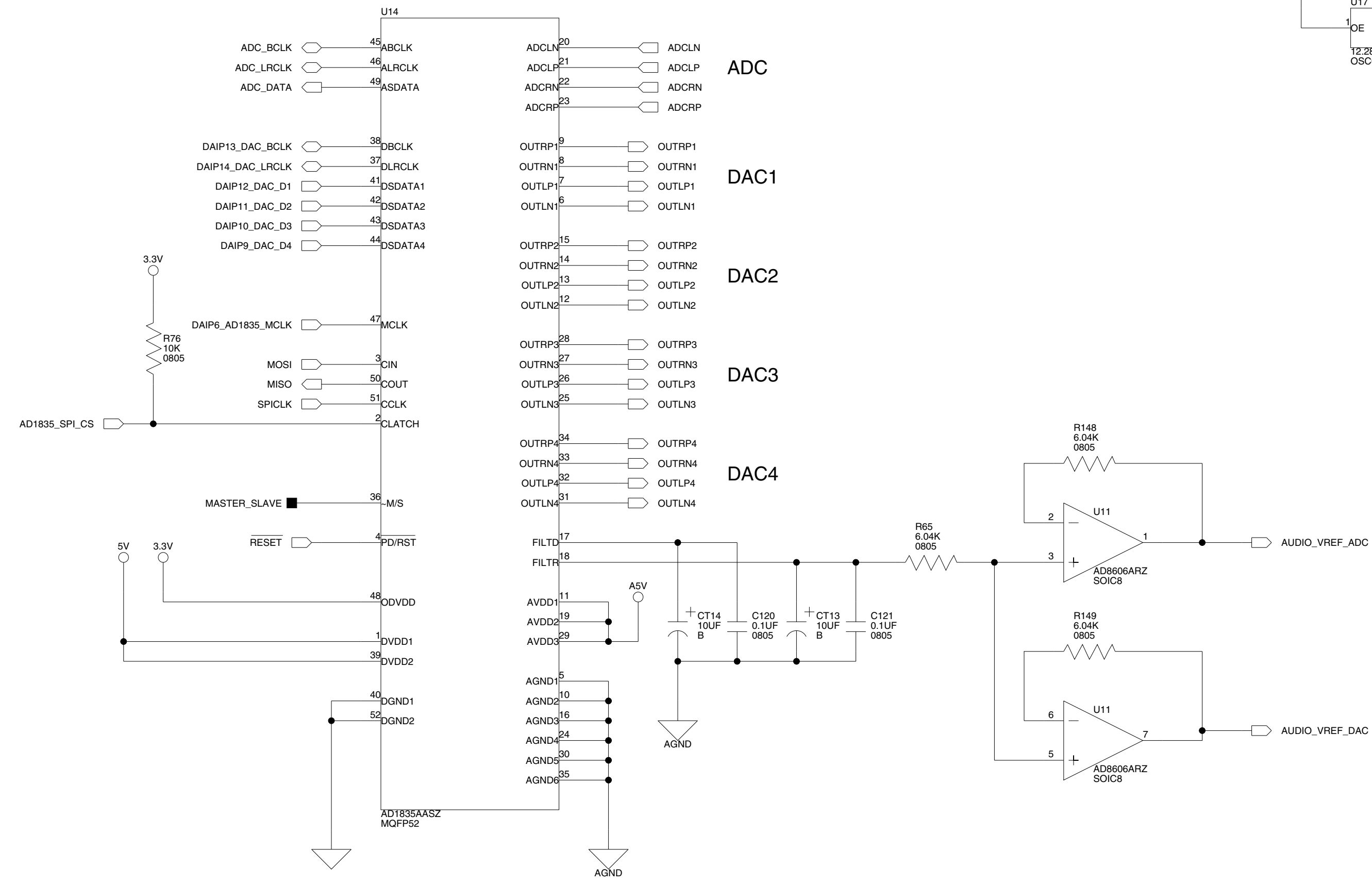

**SW7: CODEC SETUP SWITCH**  
(Default: 1=OFF, 2=ON, 3=ON, 4=ON)

1-2	Connects or disconnects the audio oscillator depending on how the system is setup. See users manual for more information.
3	OFF = AD1835 is SLAVE ON = AD1835 is MASTER
4	Disconnects ADC_DATA signal from driving the corresponding DAI signal. Useful if using this DAI pin for another purpose.

**DISCONNECTS SIGNALS FROM SPI FLASH AND AD1835**  
(Default= All ON)

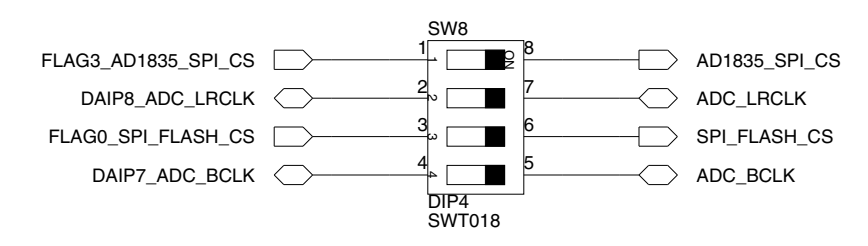

**Loopback Test Switch**  
(Default= All OFF)  
For Test Purposes Only

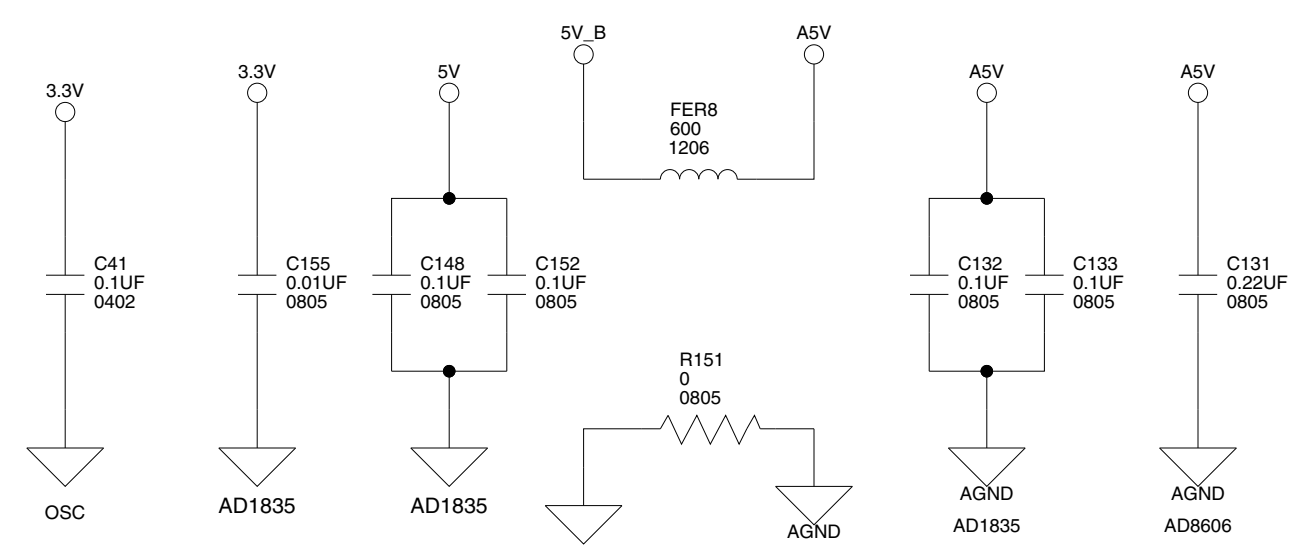
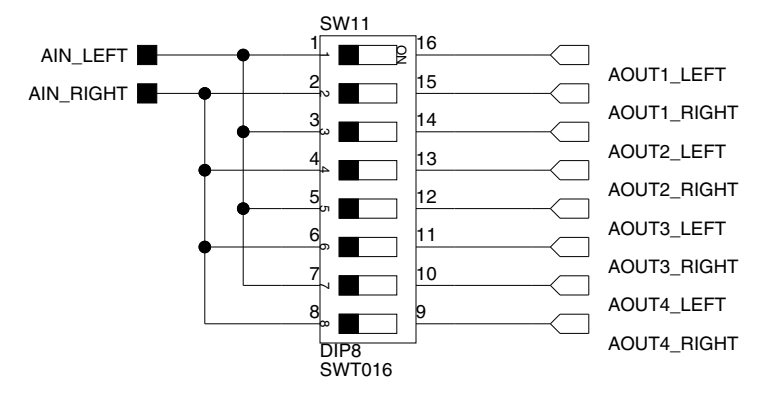

**ANALOG DEVICES**

20 Cotton Road  
Nashua, NH 03063  
PH: 1-800-ANALOGD

<b>Title</b>		<b>ADSP-21364 EZ-KIT Lite ANALOG AUDIO</b>	
<b>Size C</b>	<b>Board No.</b>	<b>A0190-2004</b>	
<b>Date</b>	5-18-2007_15:33	<b>Sheet</b>	4 of 11
		<b>Rev</b>	
		<b>2.0A</b>	

DAC1 LEFT

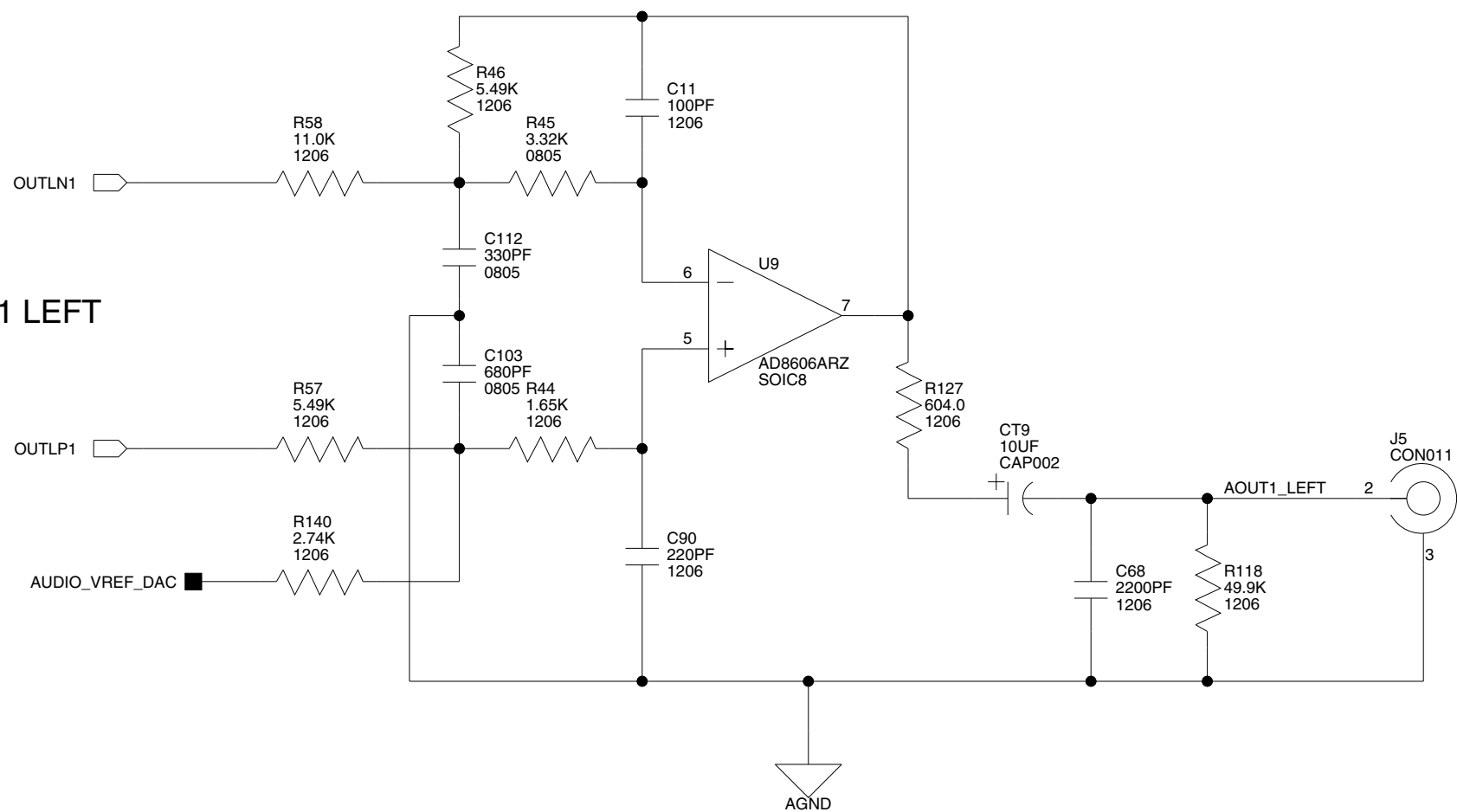

DAC2 LEFT

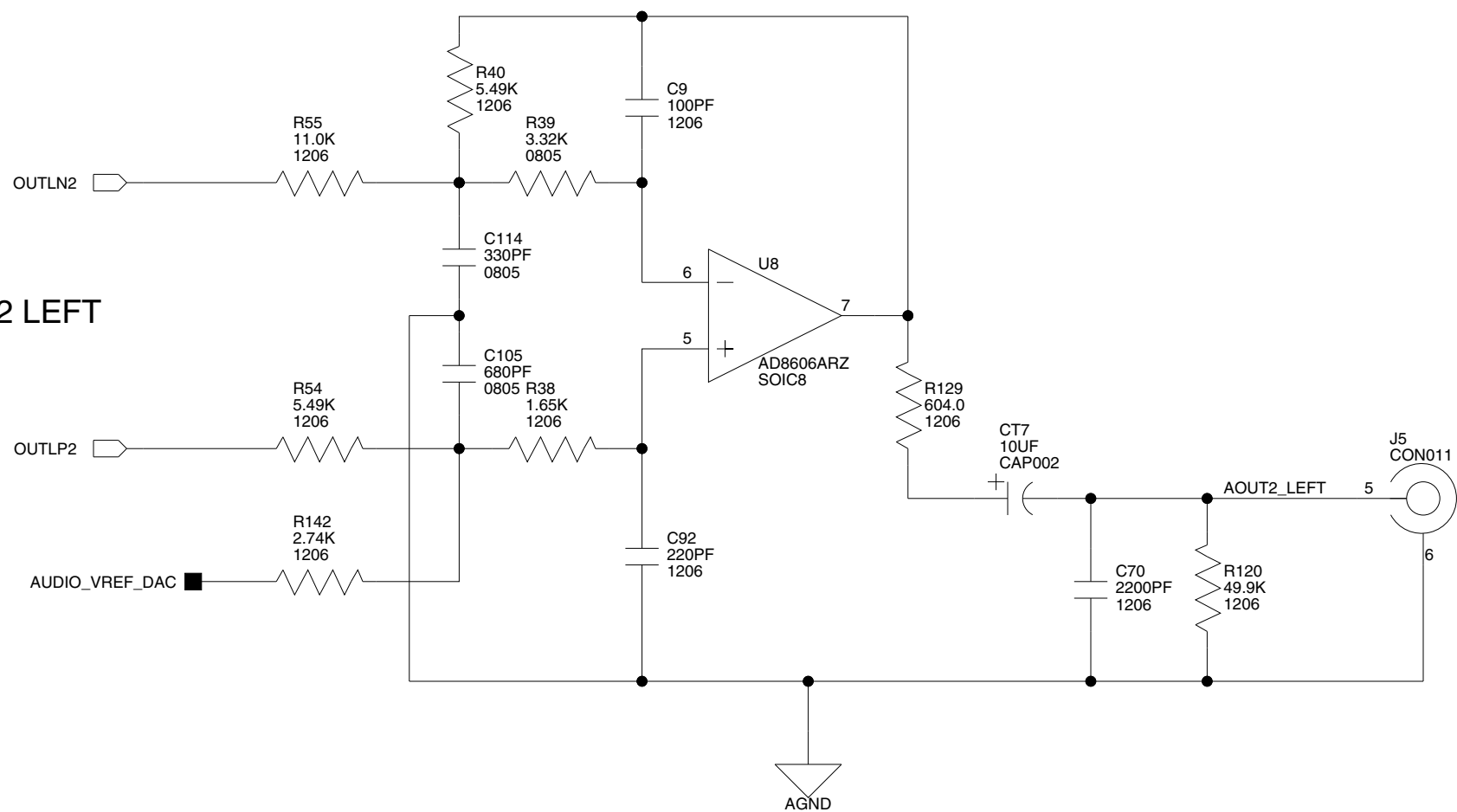

DAC1 RIGHT

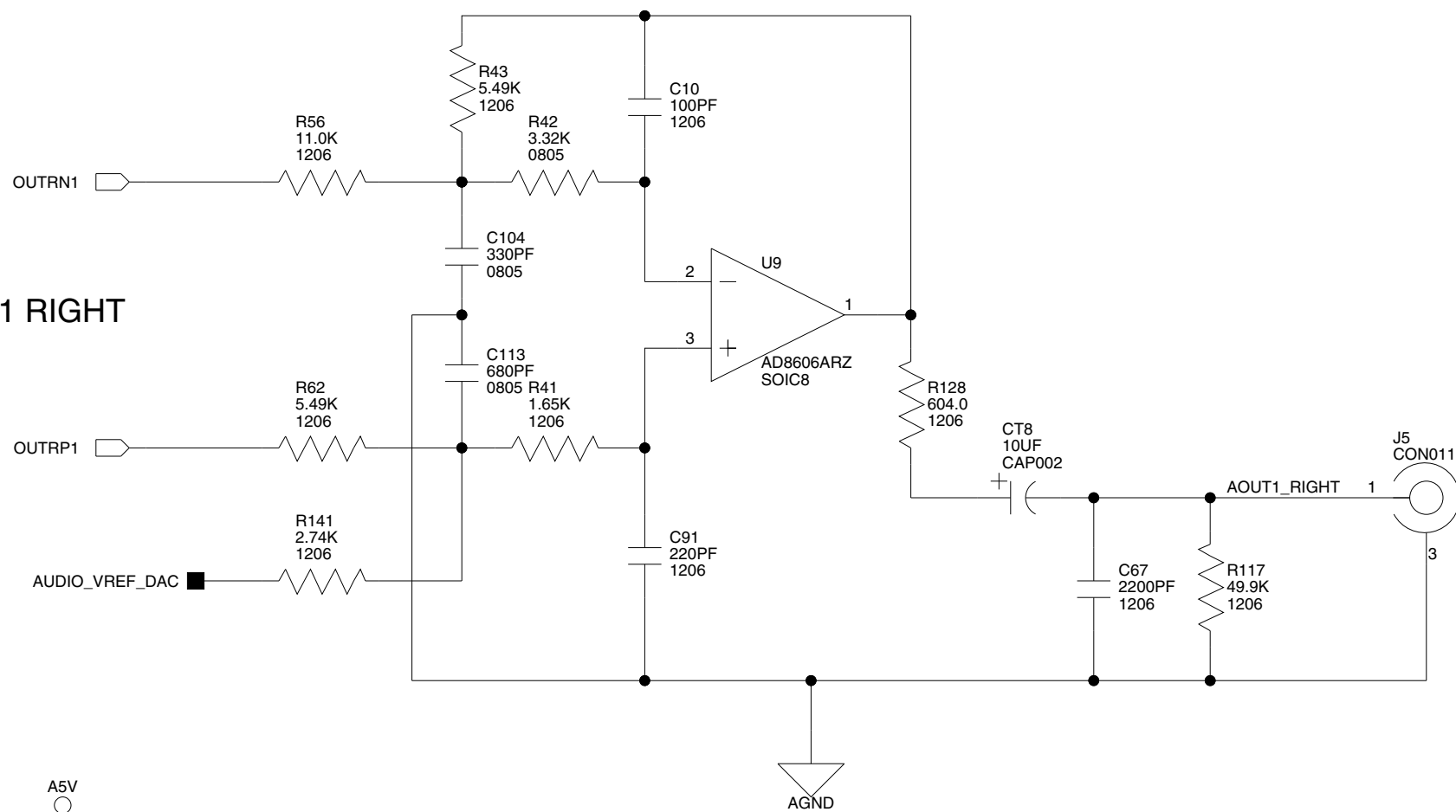

DAC2 RIGHT

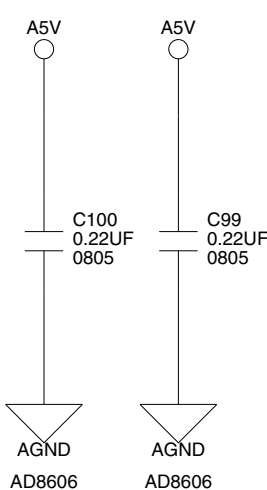
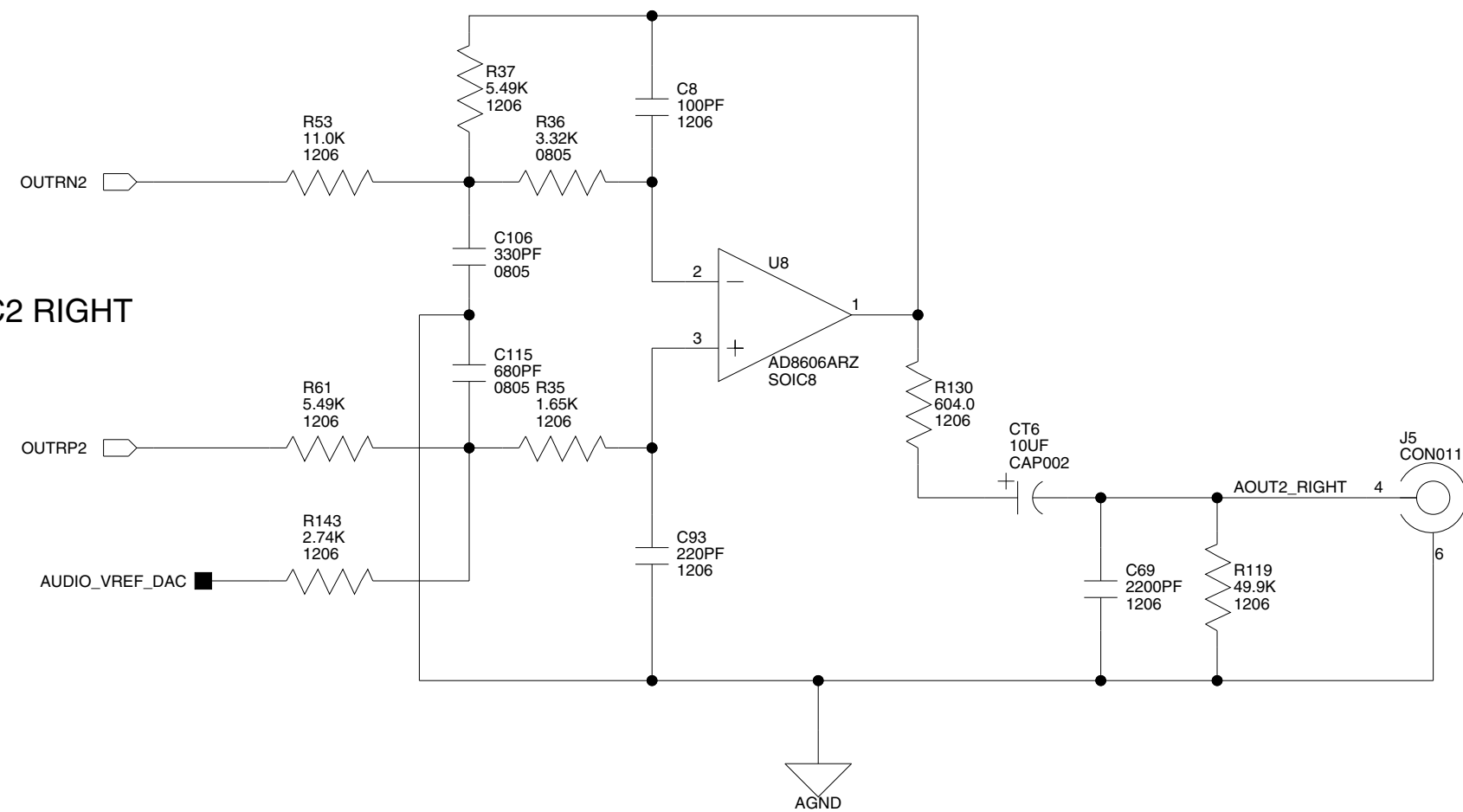

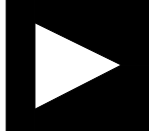
 <b>ANALOG DEVICES</b>		20 Cotton Road Nashua, NH 03063 PH: 1-800-ANALOGD	
		<b>Title</b> ADSP-21364 EZ-KIT Lite AUDIO OUT 1	
<b>Size</b> C	<b>Board No.</b> A0190-2004	<b>Rev</b> 2.0A	
<b>Date</b> 5-18-2007_15:33	<b>Sheet</b> 5 of 11		

DAC3 LEFT

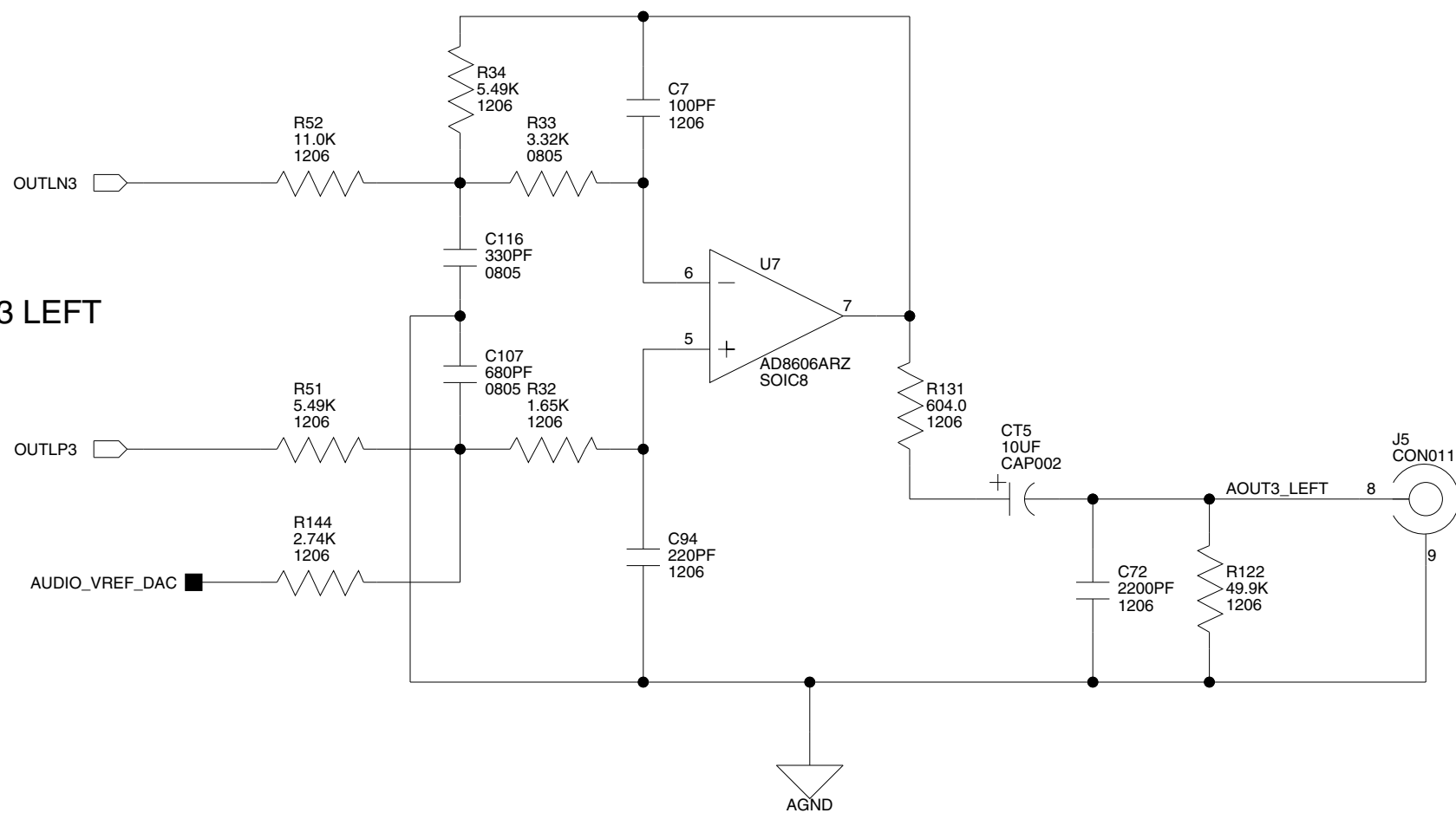

DAC4 LEFT

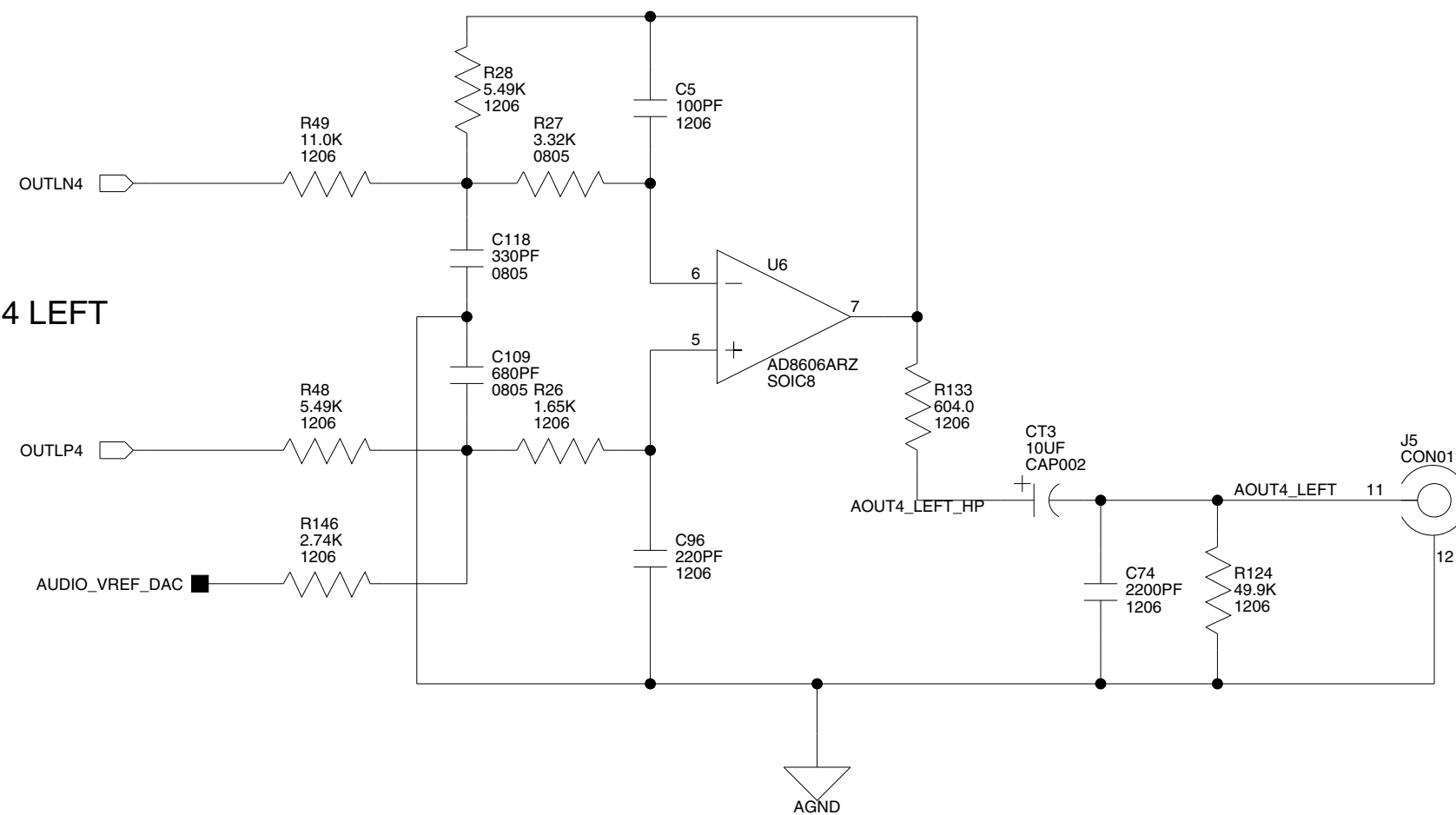

DAC3 RIGHT

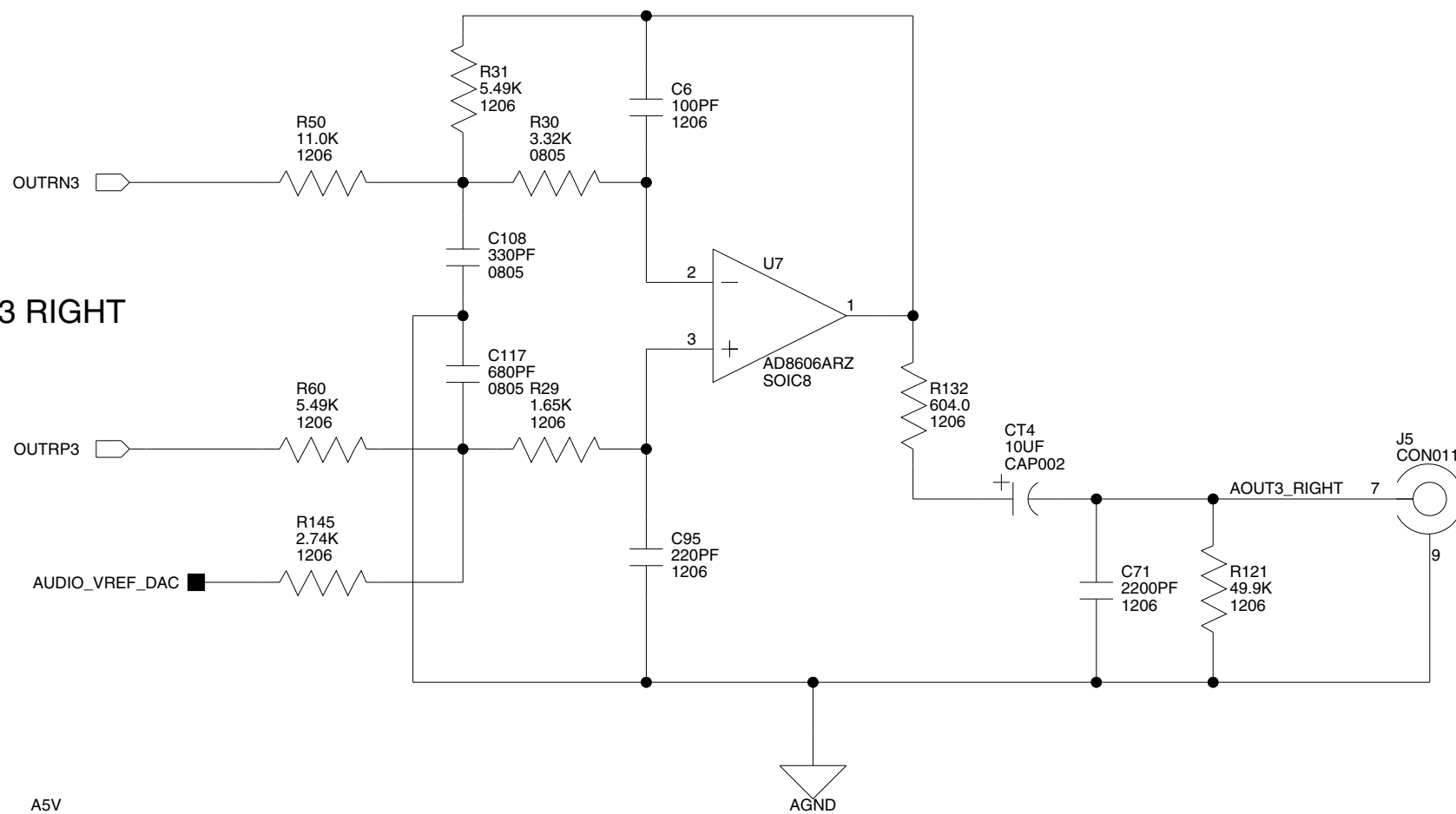

DAC4 RIGHT

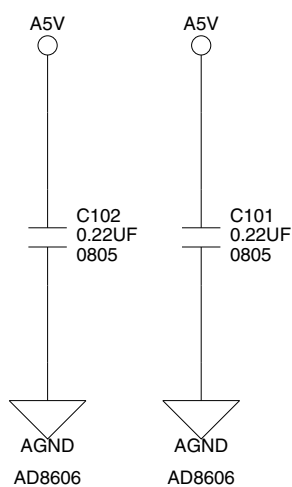
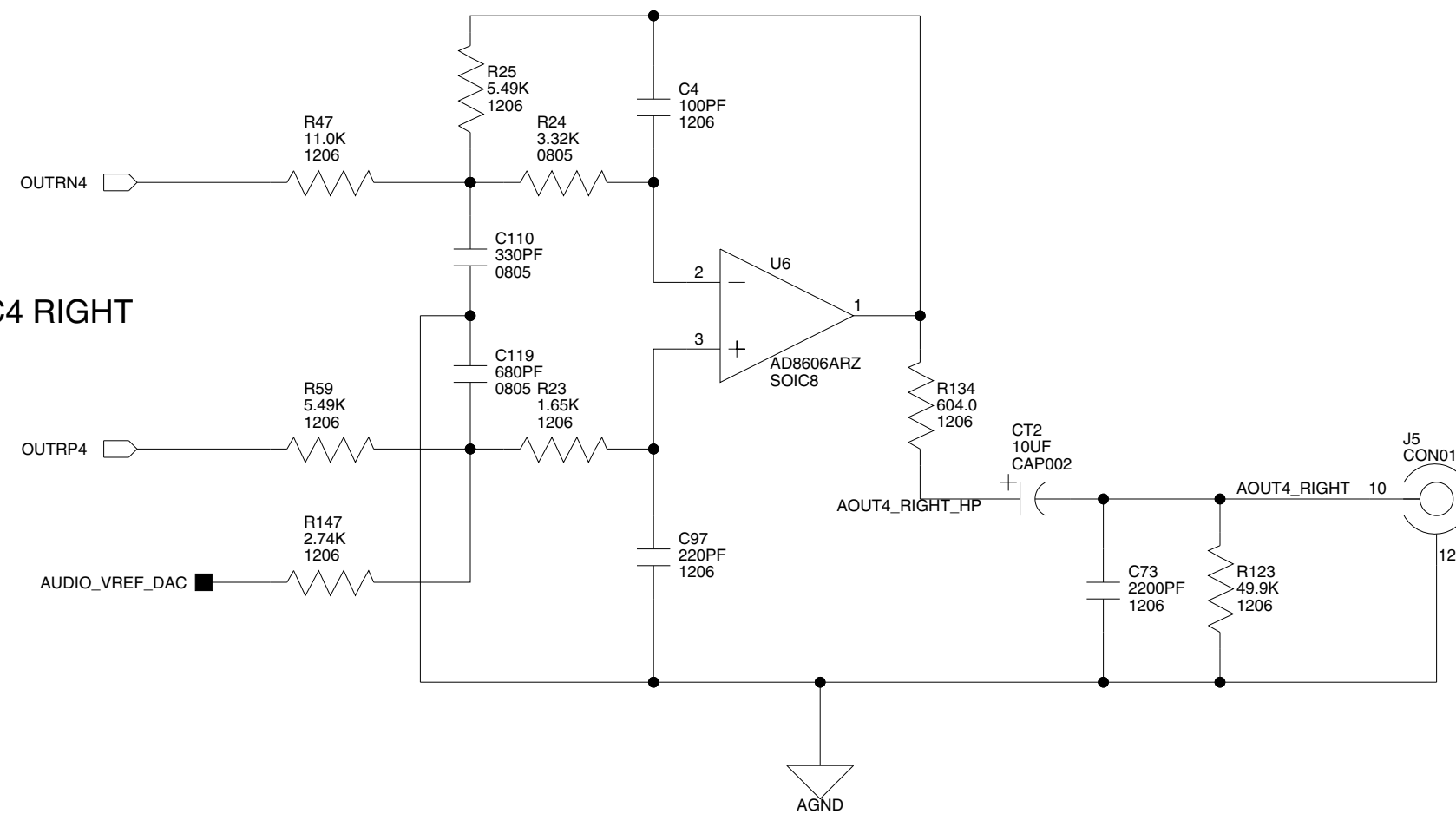

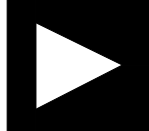
 <b>ANALOG DEVICES</b>		20 Cotton Road Nashua, NH 03063 PH: 1-800-ANALOGD	
		<b>Title</b> ADSP-21364 EZ-KIT Lite AUDIO OUT 2	
<b>Size</b> C	<b>Board No.</b> A0190-2004	<b>Rev</b> 2.0A	
<b>Date</b> 5-18-2007_15:33	<b>Sheet</b> 6 of 11		

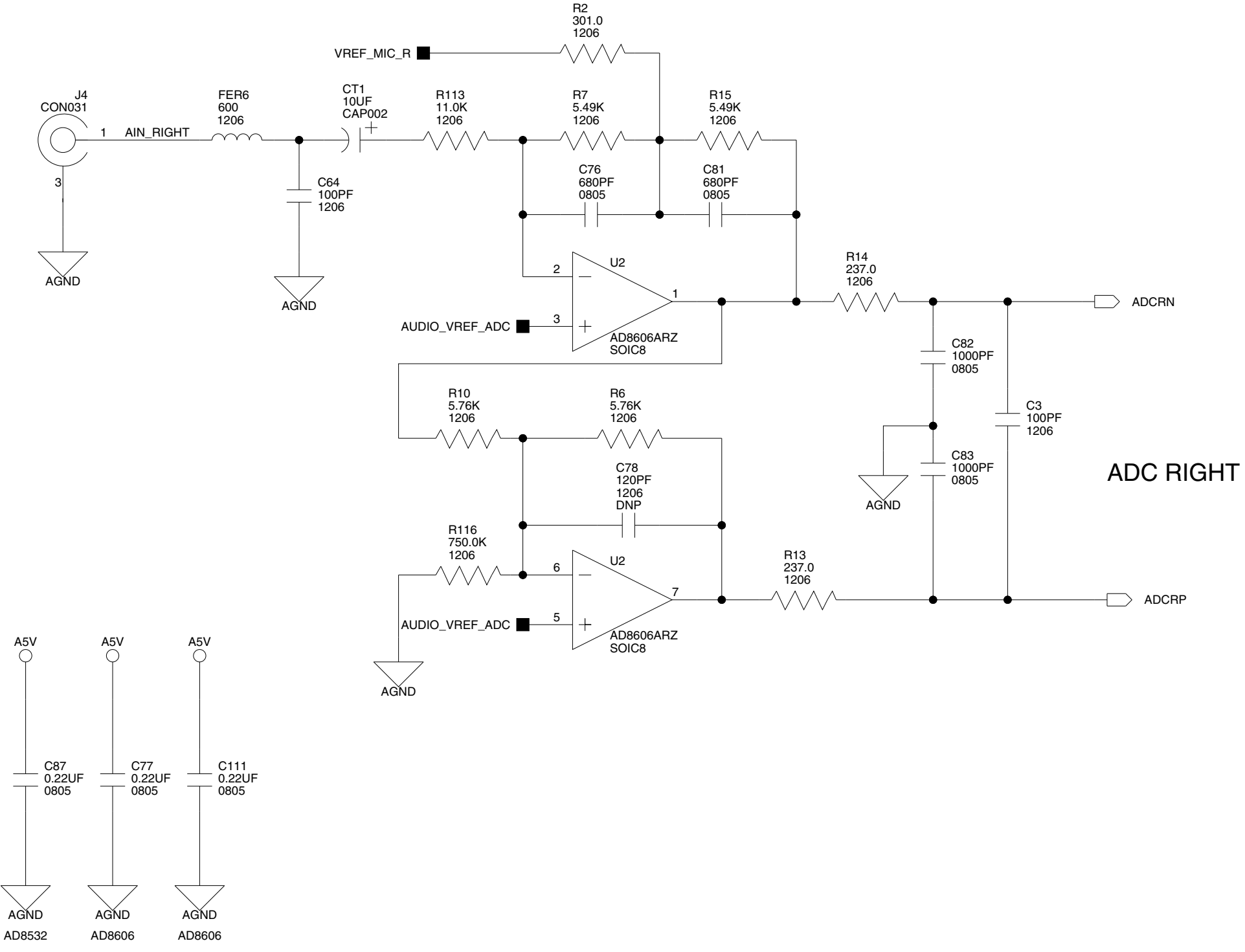
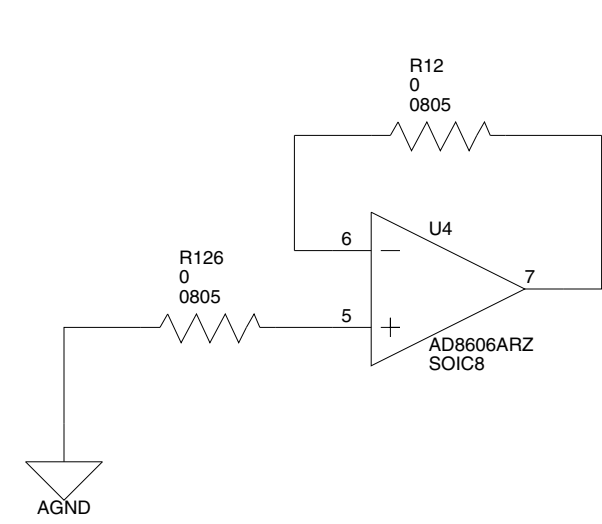
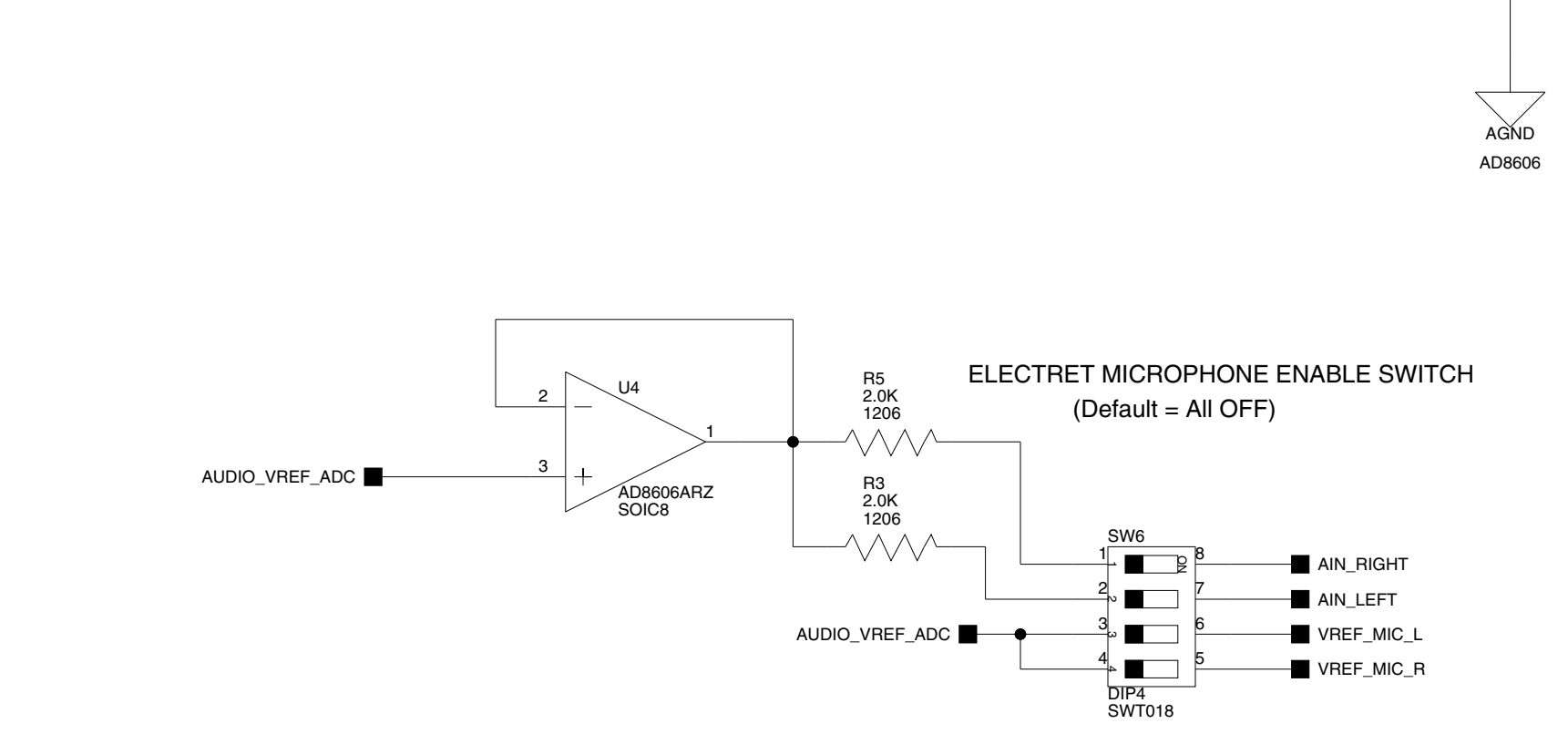
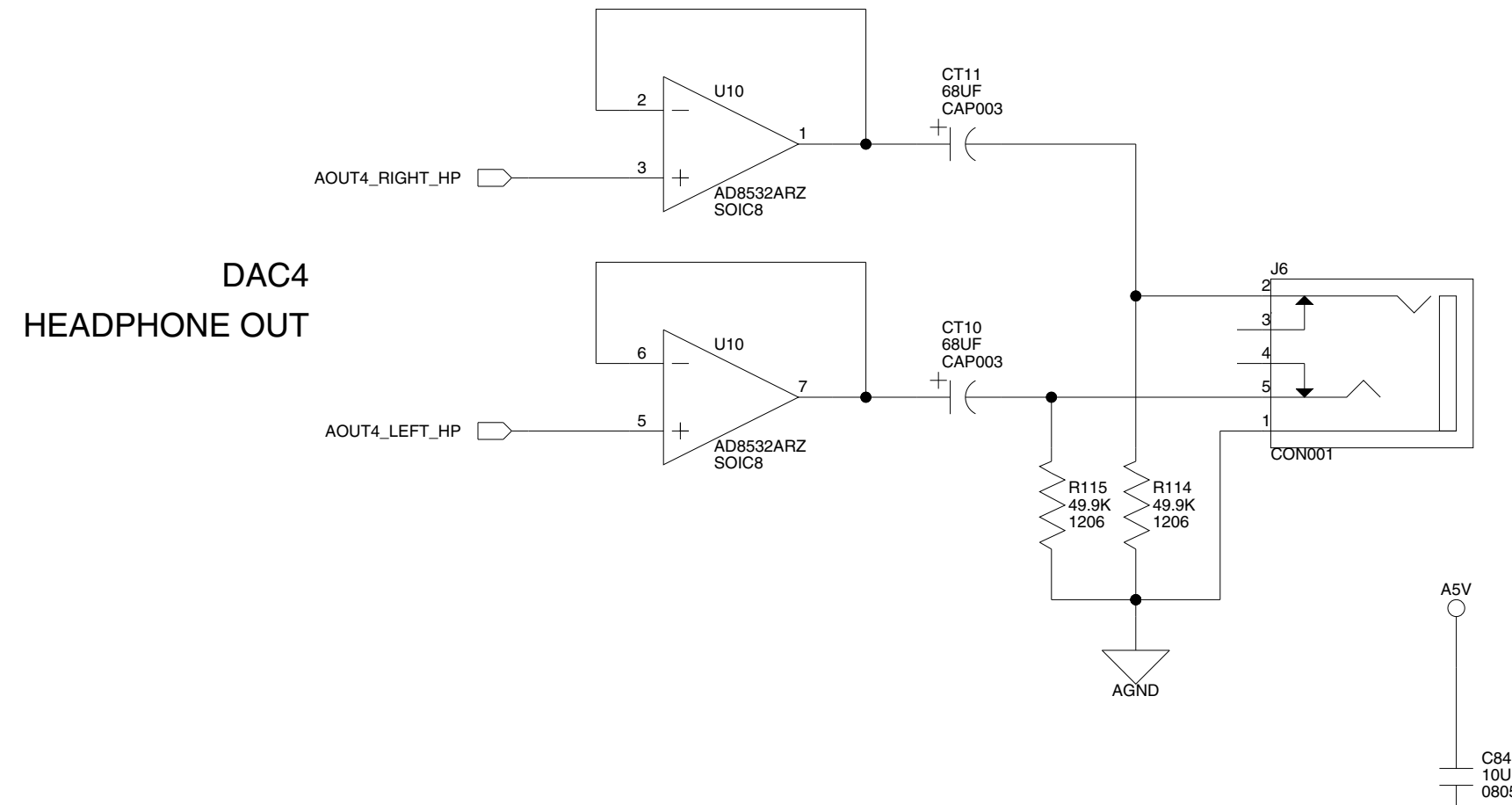
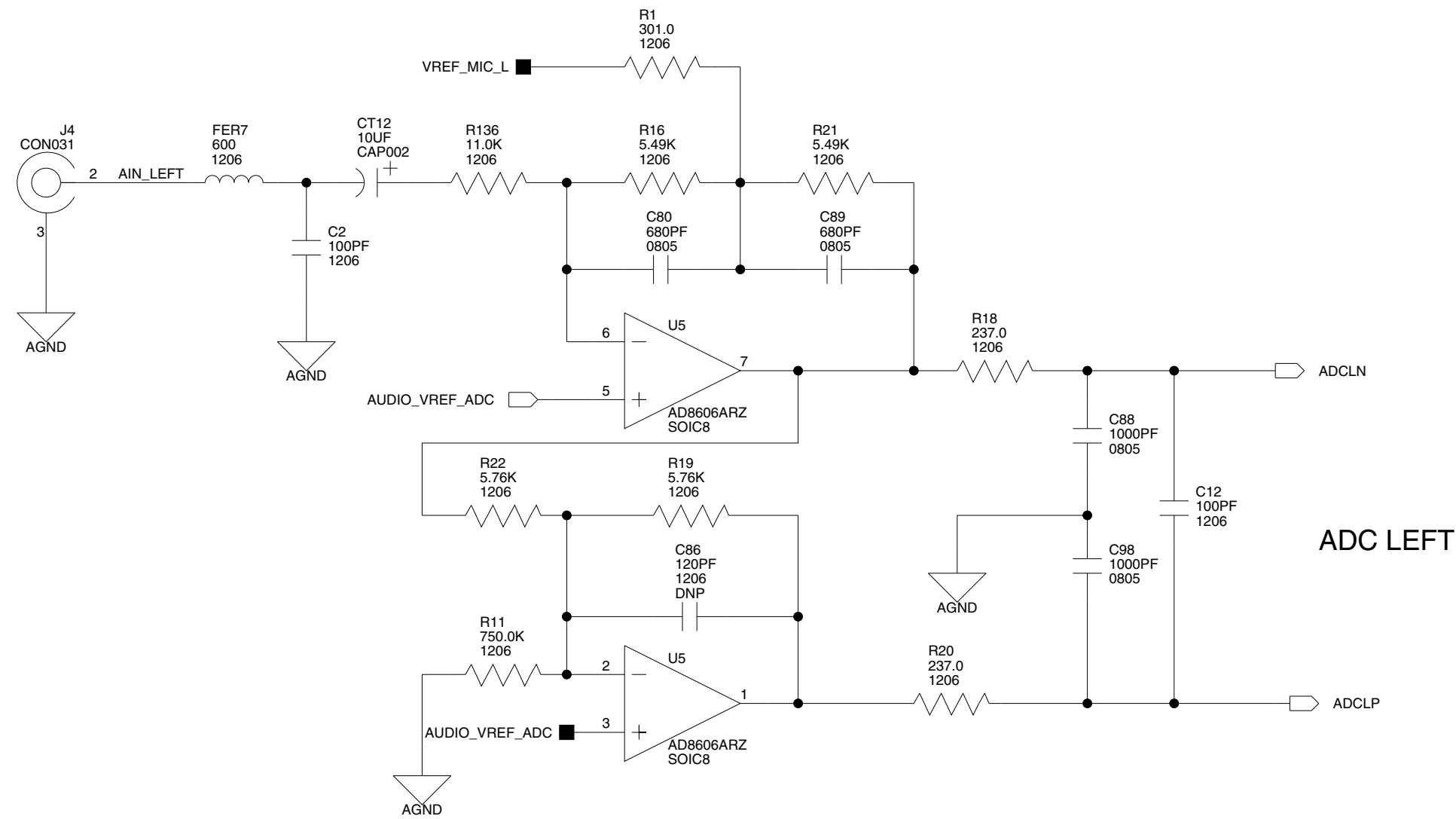

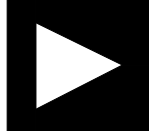
 <b>ANALOG DEVICES</b>		20 Cotton Road Nashua, NH 03063 PH: 1-800-ANALOGD	
		<b>Title</b> ADSP-21364 EZ-KIT Lite <b>AUDIO OUT 3</b>	
<b>Size</b> <b>C</b>	<b>Board No.</b> <b>A0190-2004</b>	<b>Rev</b> <b>2.0A</b>	
<b>Date</b> 5-18-2007_15:33	<b>Sheet</b> 7 of 11		

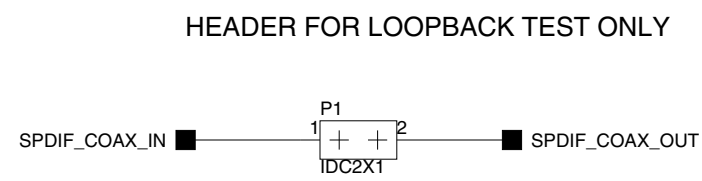
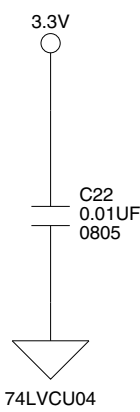
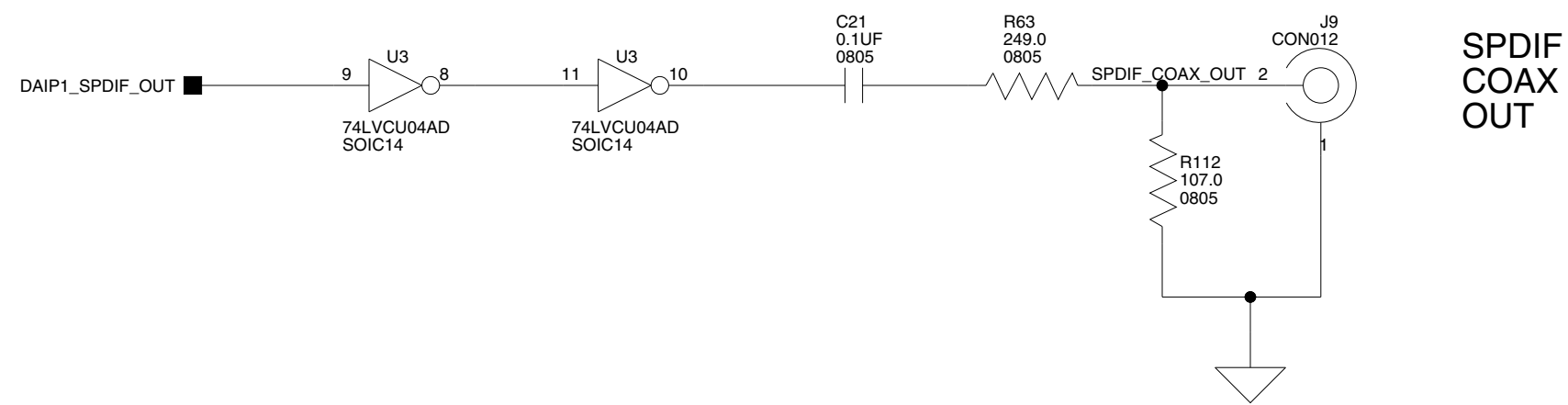
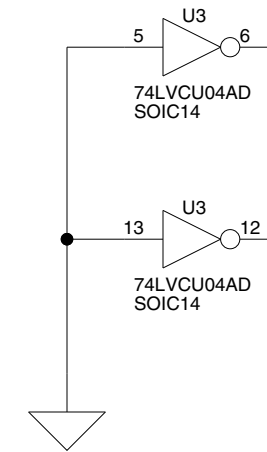
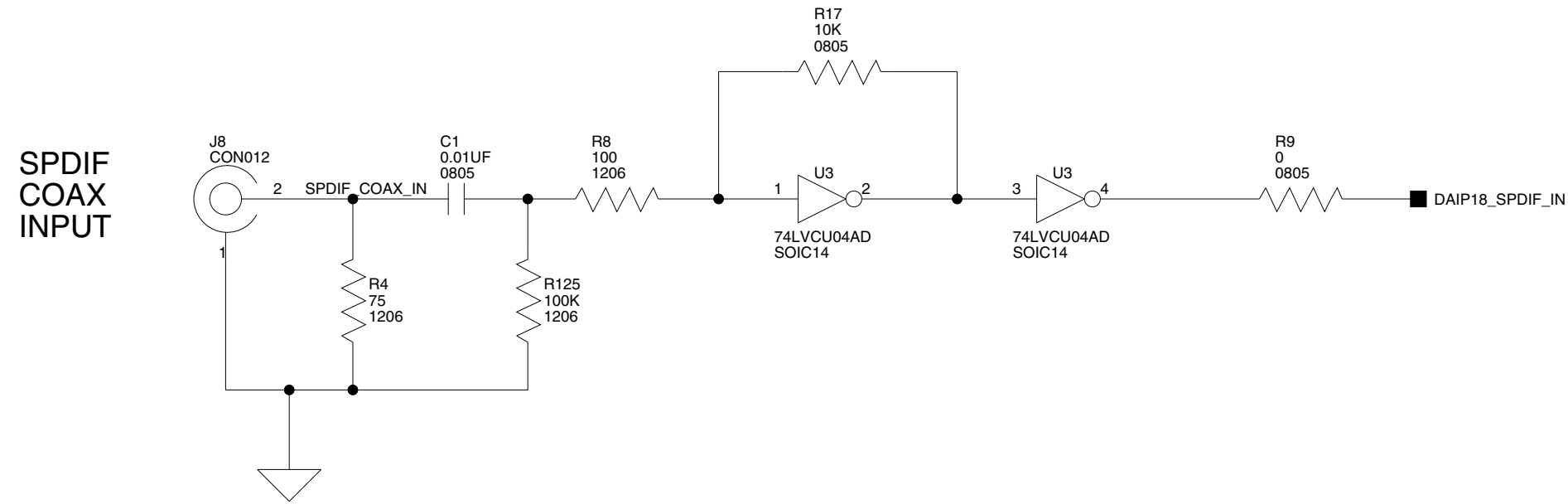

		20 Cotton Road Nashua, NH 03063 PH: 1-800-ANALOGD	
		<b>Title</b> ADSP-21364 EZ-KIT Lite SPDIF CONNECTORS	
<b>Size</b> C	<b>Board No.</b> A0190-2004	<b>Rev</b> 2.0A	
<b>Date</b> 5-18-2007_15:33	<b>Sheet</b> 8 of 11		



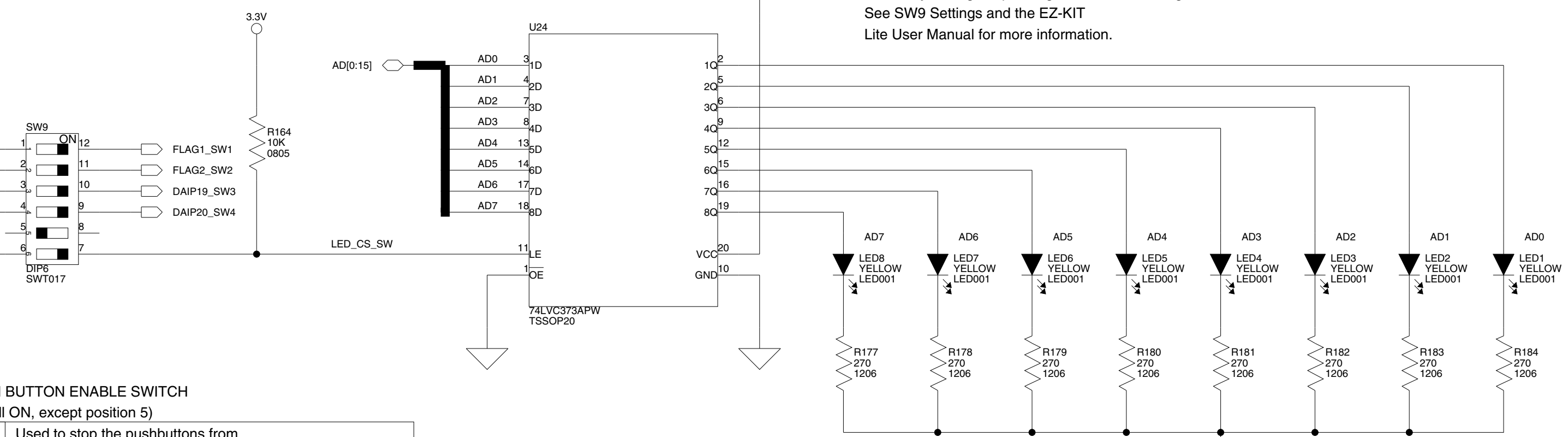
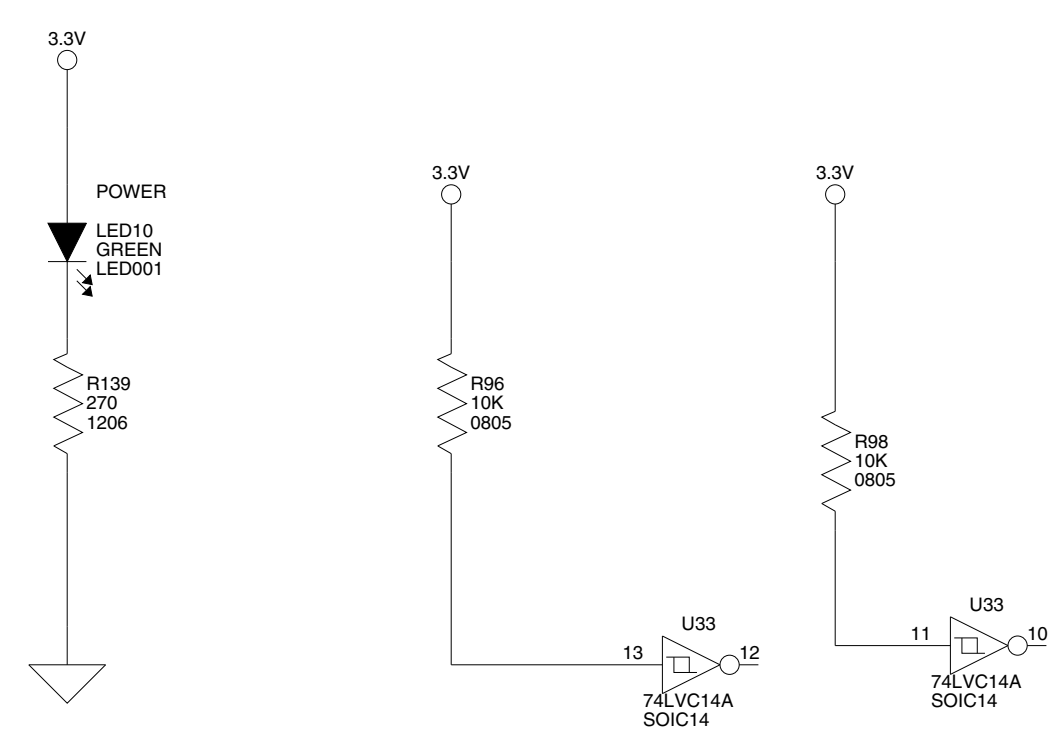
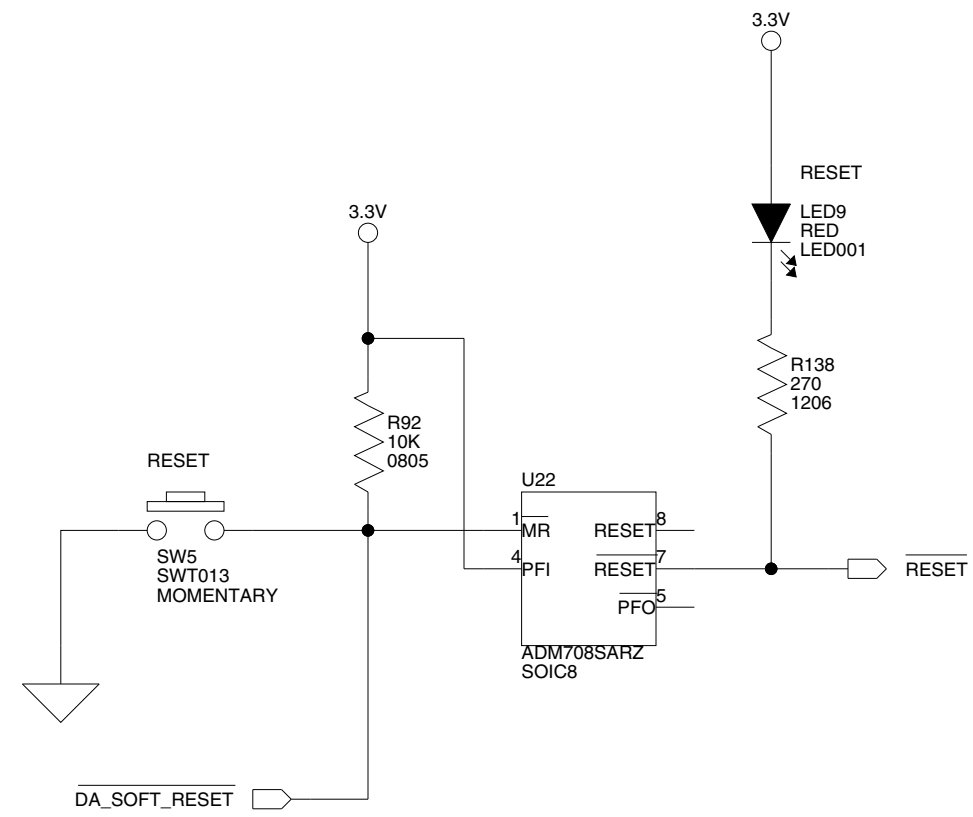
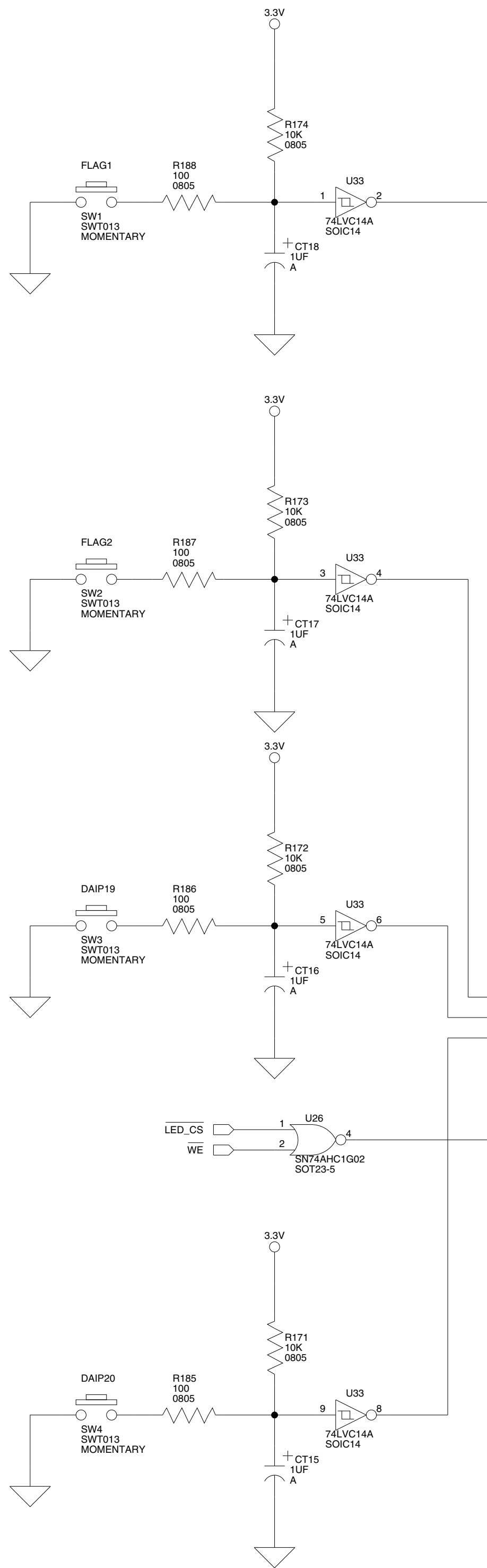

LEDs can be accessed as a memory address, or directly as flags depending on the DSP settings. See SW9 Settings and the EZ-KIT Lite User Manual for more information.

**SW9: PUSH BUTTON ENABLE SWITCH**  
(Default = All ON, except position 5)

1-4	Used to stop the pushbuttons from driving the corresponding DSP signal. Useful if using these DSP signals for another purpose.
5	Not Used
6	OFF = LEDs function as flags ON = LEDs are accessed at a memory address

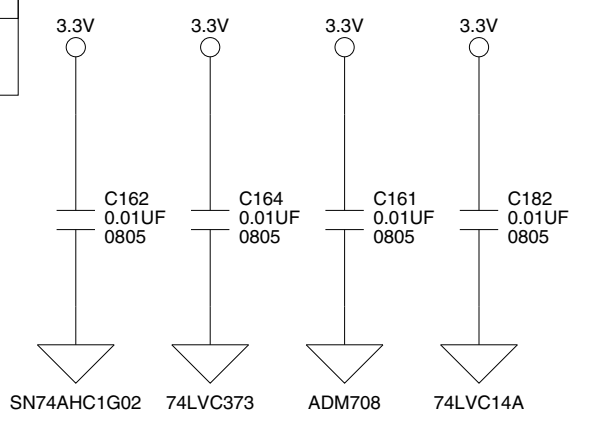

**ANALOG DEVICES**

20 Cotton Road  
Nashua, NH 03063  
PH: 1-800-ANALOGD

<b>Title</b>		<b>ADSP-21364 EZ-KIT Lite RESET/PB/LED</b>	
<b>Size C</b>	<b>Board No.</b>	<b>A0190-2004</b>	
<b>Date</b>	5-18-2007_15:33	<b>Sheet</b>	9 of 11
		<b>Rev</b>	<b>2.0A</b>

### EXPANSION INTERFACE (TYPE A)

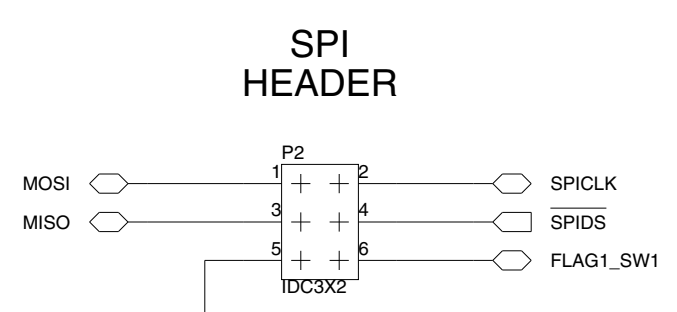
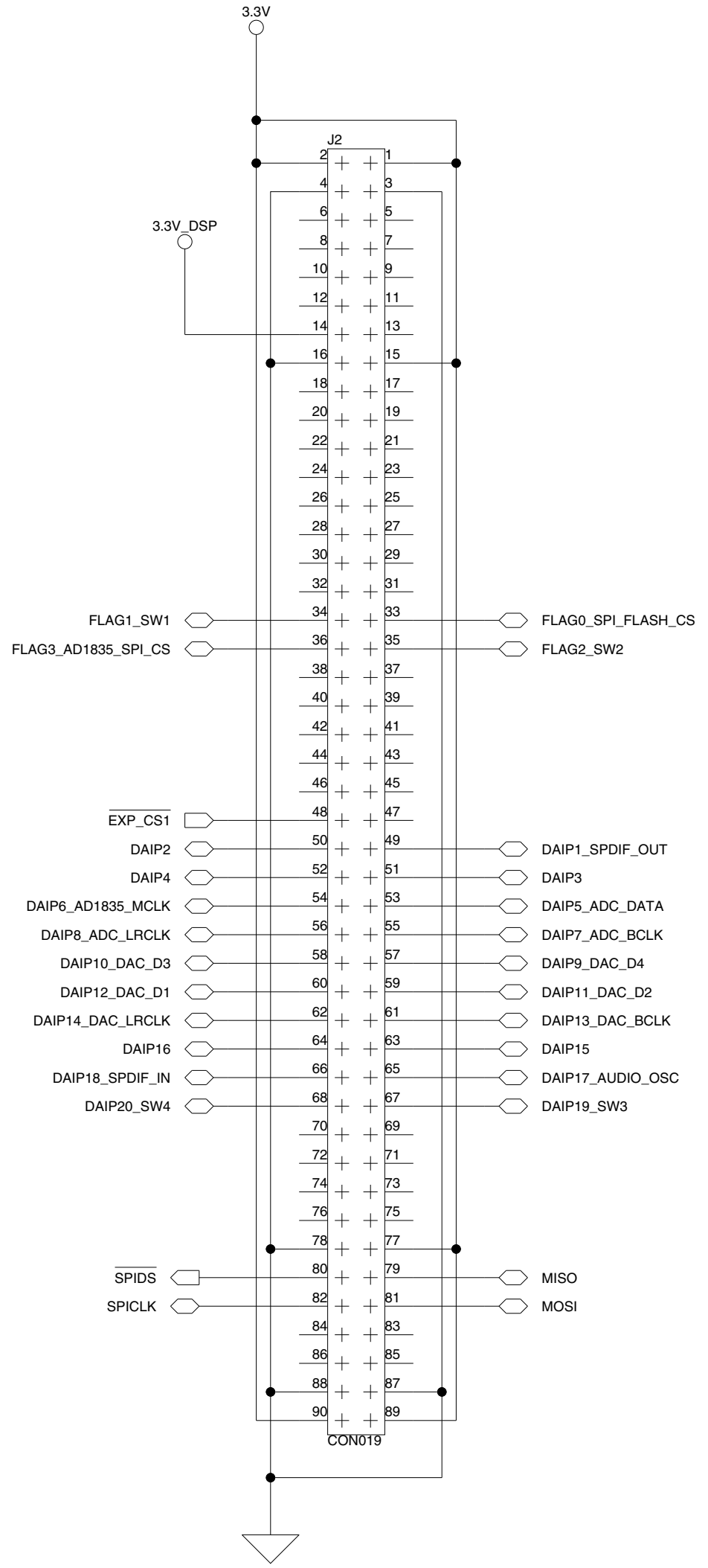
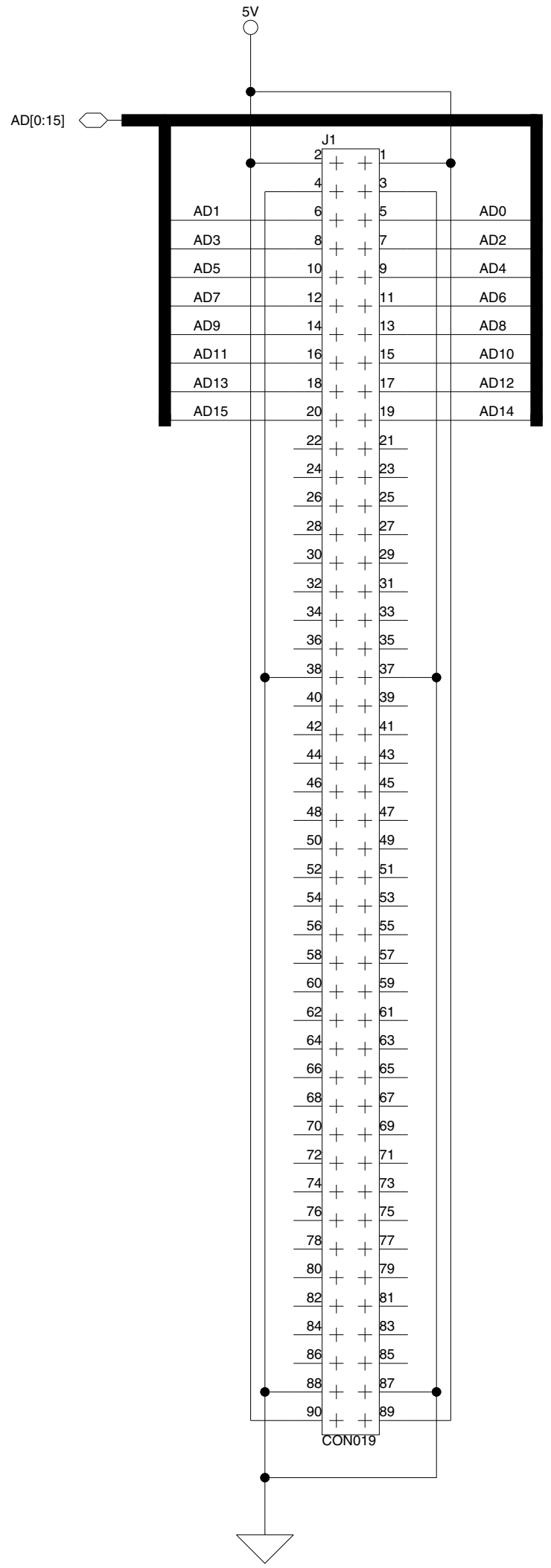

NOTE: Must disable SW1 when using this pin as SPI select.  
See page 9

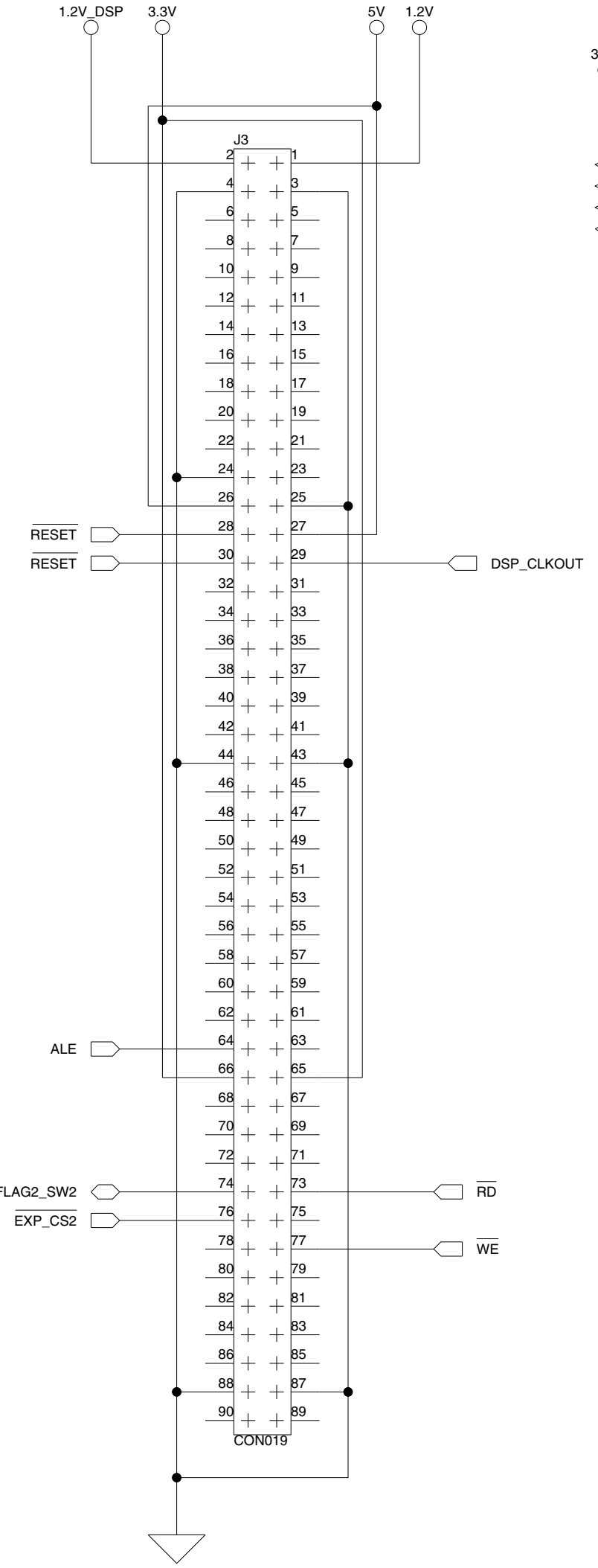

### JTAG HEADER

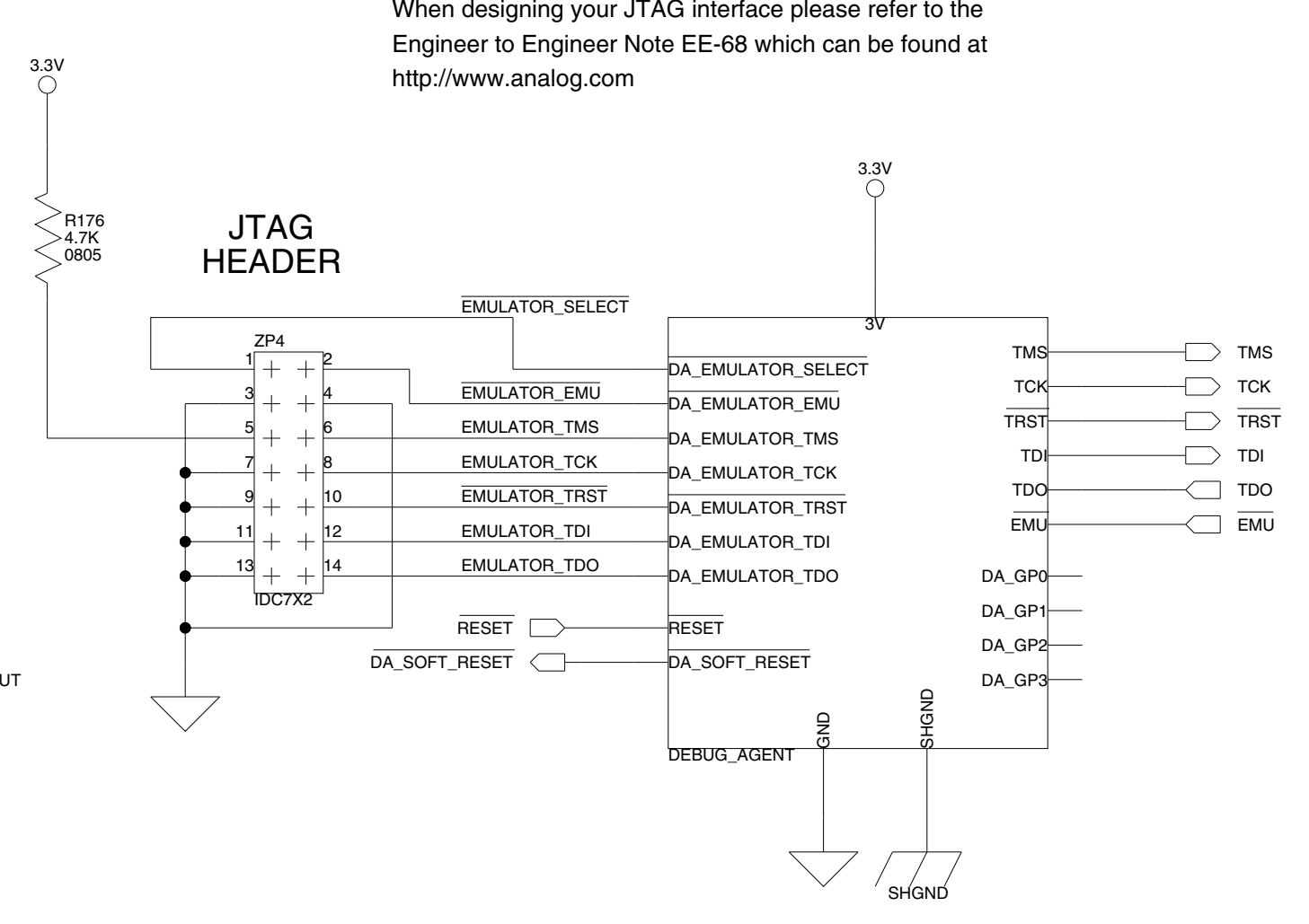

All USB interface circuitry is considered proprietary and has been omitted from this schematic.  
When designing your JTAG interface please refer to the Engineer to Engineer Note EE-68 which can be found at <http://www.analog.com>

### DAI HEADER

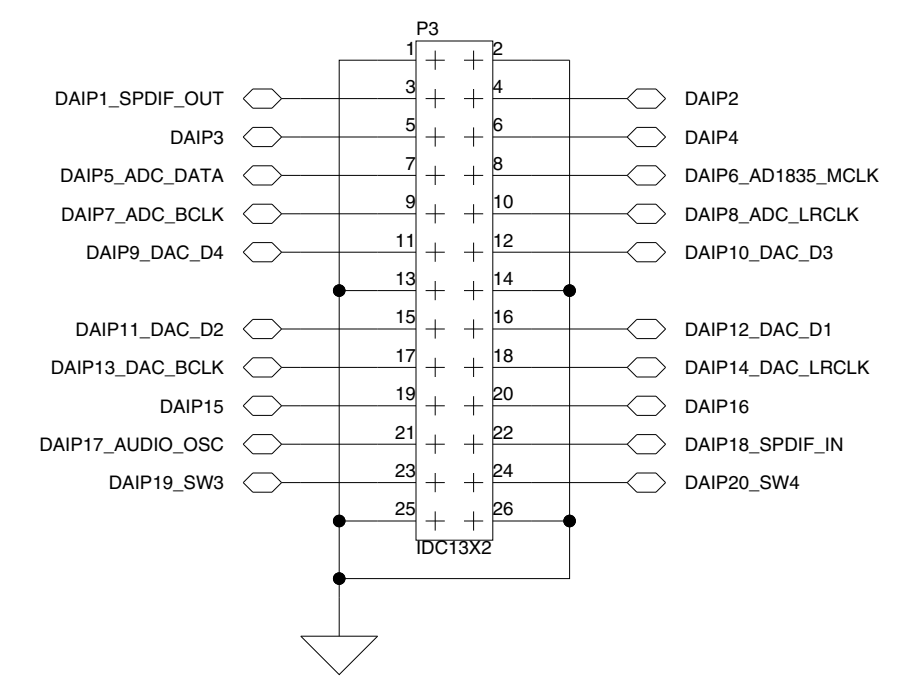

		20 Cotton Road Nashua, NH 03063 PH: 1-800-ANALOGD	
Title <b>ADSP-21364 EZ-KIT Lite EXPANSION INTERFACE/JTAG/SPI/DAI</b>			
Size <b>C</b>	Board No. <b>A0190-2004</b>	Rev <b>2.0A</b>	
Date <b>5-18-2007_15:33</b>	Sheet <b>10 of</b>		<b>11</b>

POWER IN

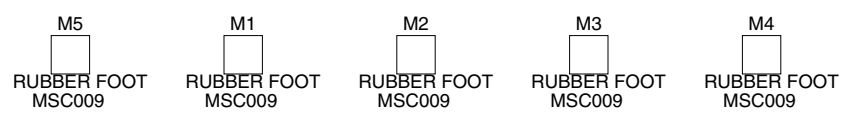
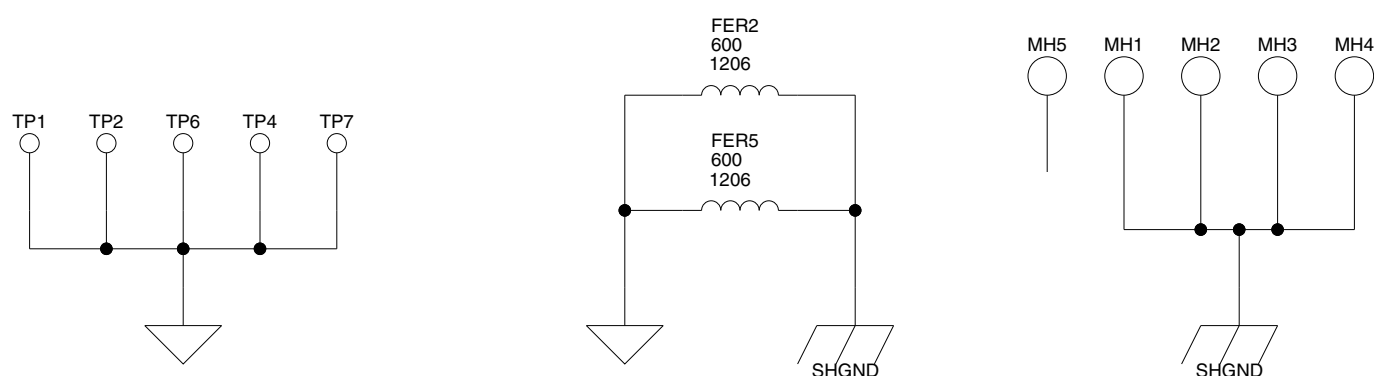
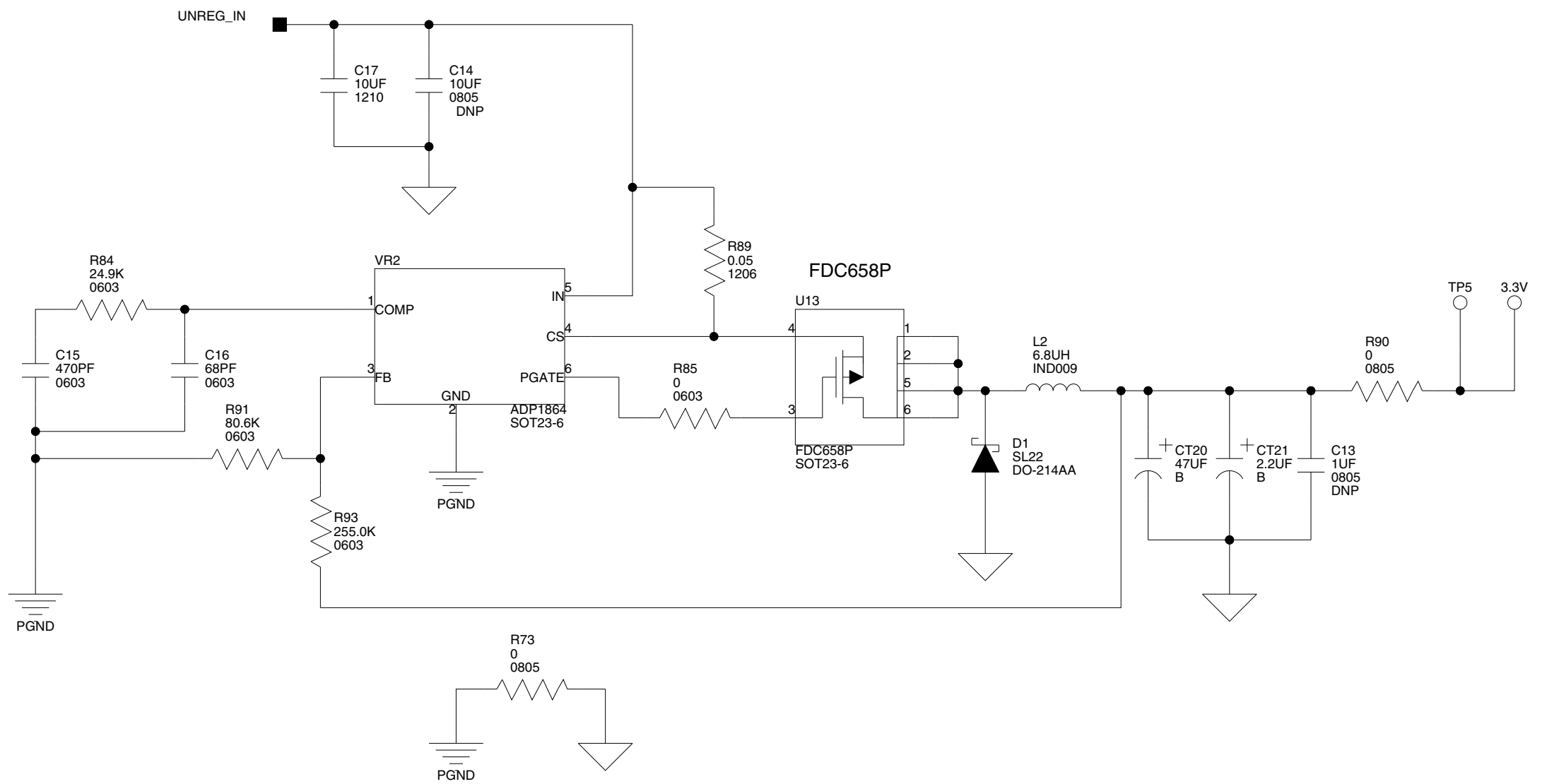
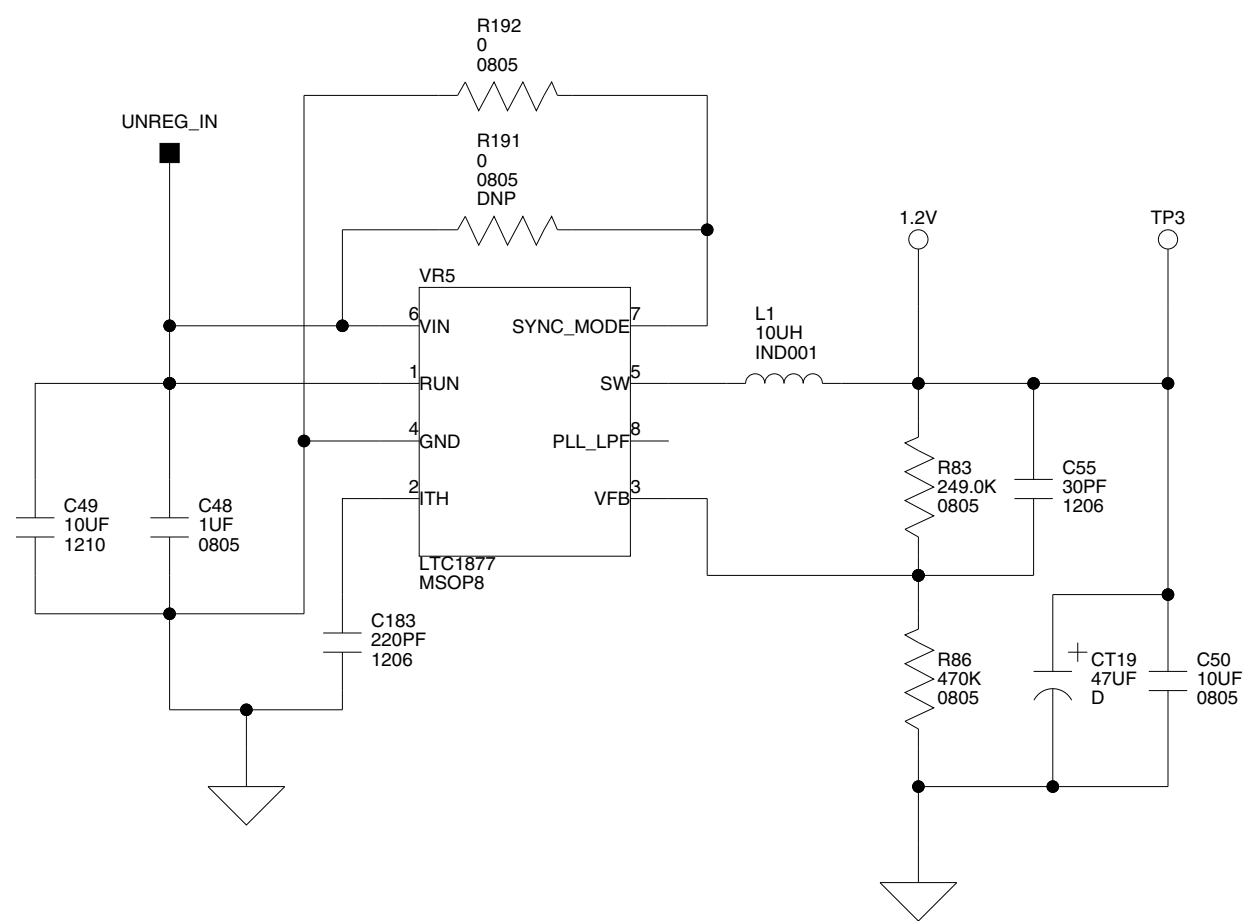
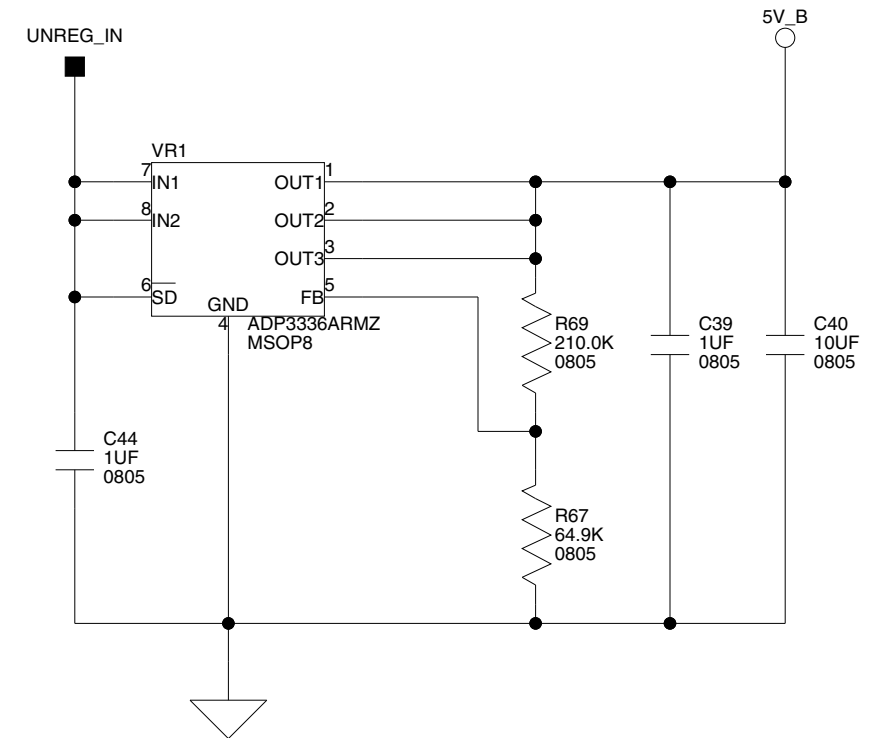
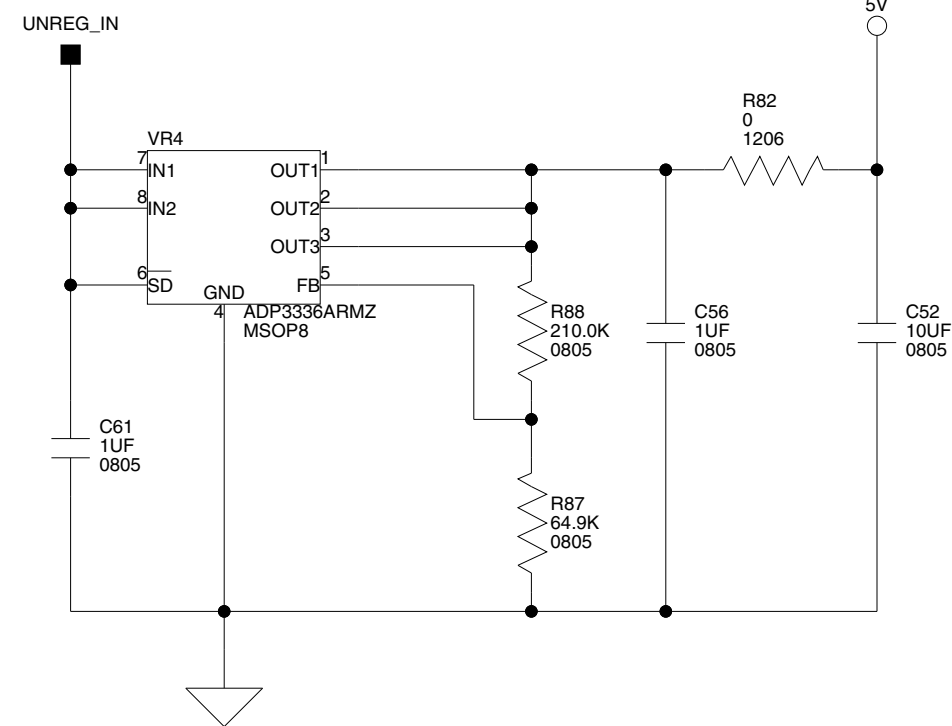
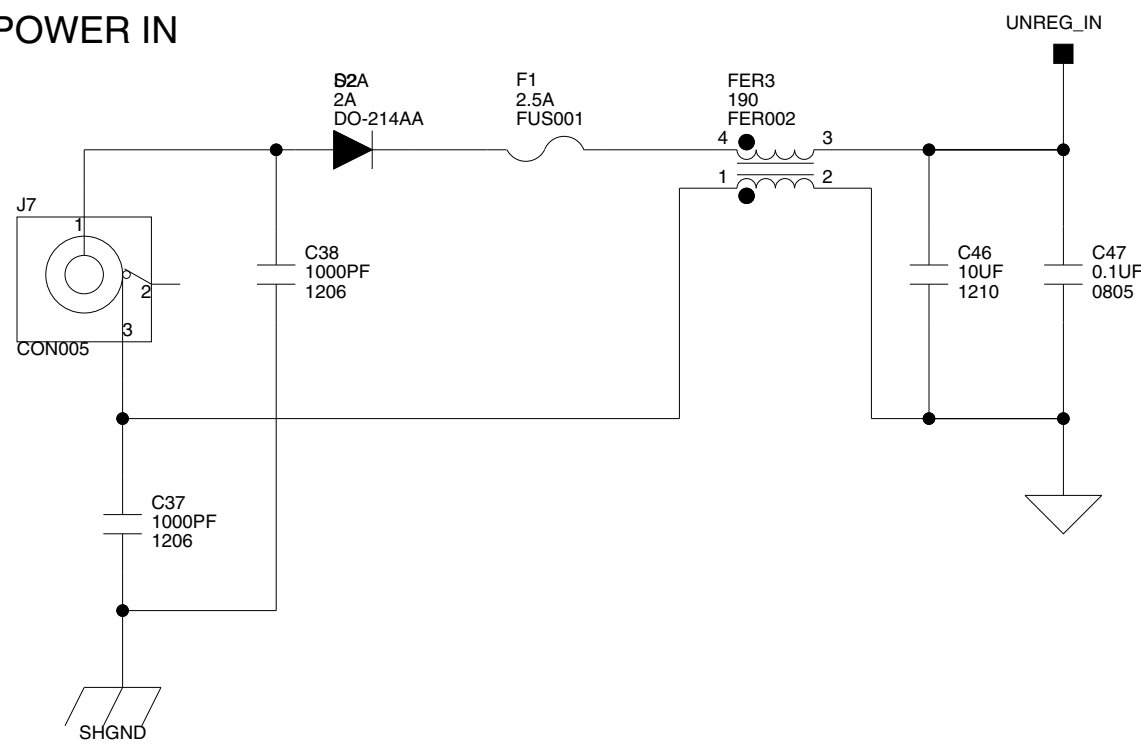

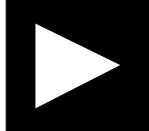
 <b>ANALOG DEVICES</b>		20 Cotton Road Nashua, NH 03063 PH: 1-800-ANALOGD	
		<b>Title</b> ADSP-21364 EZ-KIT Lite <b>POWER</b>	
<b>Size C</b>	<b>Board No.</b> A0190-2004	<b>Rev</b> 2.0A	
<b>Date</b> 5-18-2007_15:33	<b>Sheet</b> 11 of 11		

# I INDEX

## Numerics

2-wire interface (TWI) mode, [1-13](#)

## A

AD15-8 pins, [2-3](#), [2-7](#)  
AD1835, CAD and DAC  
    master clock (MCLK), [1-13](#), [2-5](#)  
AD1835A, CAD and DAC  
    configuration registers, [1-14](#), [2-6](#)  
    DAI interface, [1-13](#), [2-5](#)  
    master/slave modes, [1-13](#), [2-10](#)  
    setup switch (SW7), [2-10](#)  
    SPI interface, [2-6](#), [2-7](#)  
AD7-0 (LED8-1) pins, [1-15](#), [2-7](#), [2-11](#),  
    [2-14](#)  
ADC\_DATA pins, [2-10](#)  
ALE pins, [2-3](#), [2-11](#)  
analog audio, *See* audio, AD1835A  
analog-to-digital converters (ADCs), *See*  
    AD1835A  
architecture, of this EZ-KIT Lite, [2-2](#)  
audio  
    in RCA connector (J4), [1-14](#), [2-17](#)  
    interface, [xi](#), [1-13](#)  
    oscillators, [2-5](#), [2-10](#)  
    out RCA connector (J5), [2-18](#)

## B

bill of materials, [A-1](#)  
board design database, [1-16](#)  
board schematic (ADSP-21364), [B-1](#)  
boot  
    configuration pins (BOOTCFG1-0),  
        [2-12](#)  
    modes, [2-3](#), [2-12](#)

## C

CCES environment, [1-6](#)  
CLKCFG1-0 pins, [2-3](#), [2-12](#)  
CLKIN pins, [2-3](#)  
clock  
    multiplier ratios, [2-12](#)  
    routing, [2-10](#)  
codecs, *See* AD1835A  
configuration, of this EZ-KIT Lite, [1-3](#)  
connectors  
    diagram of locations, [1-3](#), [2-16](#)  
    J1-3 (expansion interface), [2-4](#), [2-6](#), [2-7](#),  
        [2-17](#)  
    J4 (audio in RCA), [1-14](#), [2-17](#)  
    J5 (audio out RCA), [1-14](#), [2-18](#)  
    J6 (headphone out), [1-14](#), [2-18](#)  
    J7 (power), [1-8](#), [2-18](#)  
    J8-9 (S/PDIF in coax), [2-19](#)  
    P2 (SPI header), [2-6](#), [2-19](#)  
    P3 (DAI header), [2-6](#), [2-20](#)  
    ZJ1 (USB), [1-8](#), [2-20](#)  
    ZP4 (JTAG), [2-8](#), [2-21](#)

# Index

conventions, manual, [xvii](#)

core

clock rates, [2-12](#)

frequency, [2-3](#)

to CLKIN ratios, [2-12](#)

voltage, [2-2](#)

## D

DAI

block diagram, [2-4](#)

connections, [2-10](#), [2-11](#)

header (P3), [2-20](#)

DAI\_P17 pins, [2-10](#)

DAI\_P19-20 (SW3-4) pins, [1-15](#), [2-11](#),  
[2-15](#)

DAIP6 pins, [2-10](#)

default configuration, of this EZ-KIT Lite,  
[1-3](#)

digital audio interface, *See* DAI

digital-to-analog converters (DACs), *See*  
AD1835A

DIP switch SW9, [1-3](#), [1-14](#), [2-11](#)

## E

electret microphone, [1-14](#), [2-9](#)

evaluation license

CCES, [1-10](#)

example programs, [1-16](#)

expansion interface, [2-4](#), [2-6](#), [2-7](#), [2-17](#)

external memory, [1-12](#)

## F

features, of this EZ-KIT Lite, [x](#)

FLAG0 (SPI flash) pins, [1-12](#), [2-6](#), [2-7](#)

FLAG1 (SW1/SPI) pins, [1-15](#), [2-7](#), [2-11](#),  
[2-19](#)

FLAG2 (SW2) pins, [1-15](#), [2-7](#), [2-11](#)

FLAG3 (AD1835A select) pins, [1-14](#), [2-6](#),  
[2-7](#)

FLAG registers, [1-14](#), [2-14](#)

flash memory

boot mode (default), [2-12](#)

start/end addresses, [1-12](#)

via parallel port, [1-12](#), [2-3](#)

frame sync/clock signals, [1-13](#), [2-10](#)

frequency, [2-3](#)

## G

general-purpose IO pins, [1-14](#), [1-15](#), [2-3](#),  
[2-6](#), [2-14](#), [2-15](#)

## H

headphone jack (J6), [xi](#), [2-18](#)

## I

installation, of this EZ-KIT Lite, [1-8](#)

CCES, [1-4](#)

internal boot mode, [2-12](#)

IO

sample rates, [1-13](#)

voltage, [2-2](#)

## J

JTAG

connector (ZP4), [2-21](#)

emulation port, [2-8](#)

## L

latch-enable pin (ALE), [1-15](#), [2-3](#), [2-11](#)

$\overline{\text{LED\_CS}}$  signals, [2-11](#)

## LEDs

- diagram of locations, [1-3](#), [2-13](#)
- LED10 (power), [1-8](#), [2-14](#)
- LED1-8 (general-purpose IO), [1-15](#), [2-14](#)
- LED9 (processor reset), [1-8](#), [2-14](#)
- ZLED3 (USB monitor), [1-8](#), [2-14](#)

license restrictions, [1-11](#)

loop-back test switch (SW11), [2-13](#)

## M

master input clock (MCLK), [1-13](#), [2-5](#)

memory bus (AD15-0), [2-3](#)

## N

notation conventions, [xvii](#)

## O

oscillators, [1-13](#), [2-3](#)

## P

package contents, [1-2](#)

parallel flash memory, *See* flash memory

parallel port (PP)

- boot mode, [2-3](#), [2-12](#)
- connections, [1-12](#), [1-15](#), [2-3](#)
- control signals, [2-7](#)

PMCTL register, [2-3](#)

power

- connector (J7), [2-18](#)
- LED (LED10), [2-14](#)
- supply, [1-2](#), [2-19](#)

PPFLG bits, [1-12](#), [1-15](#)

push buttons

- See also* switches by name (SW<sub>x</sub>)
- diagram of locations, [1-14](#), [2-13](#)

## R

R79-80 resistors, [2-2](#)

RCA connectors, [xi](#), [1-14](#), [2-5](#)

related documents, [xvii](#)

reset

- processor (LED9), [2-14](#)
- push button (SW5), [2-15](#)

restrictions, of the licence, [1-11](#)

## S

sample rates, [1-13](#)

schematic, of ADSP-21364 EZ-KIT Lite,  
[B-1](#)

serial peripheral interface, *See* SPI

signal routing units (SRUs), [1-13](#), [2-4](#)

S/PDIF

- connectors (J8-9), [2-19](#)
- receivers, [1-13](#)

SPI

- connections, [2-6](#)
- disable switch (SW8), [2-11](#)
- flash memory, [1-12](#), [2-6](#), [2-7](#)
- header (P2), [2-19](#)
- master boot mode, [2-3](#), [2-12](#)
- port, [1-12](#), [1-14](#)
- slave boot mode, [2-12](#)

SRAM

- configuration, [1-12](#)
- via parallel port, [2-3](#)

startup, of this EZ-KIT Lite, [1-8](#)

CCES, [1-4](#)

SW10 (boot mode/clock ratio) switch, [2-3](#),  
[2-12](#)

SW11 (loop-back test) switch, [2-13](#)

SW1-2 (FLAG1-2) push buttons, [1-15](#),  
[2-7](#), [2-11](#), [2-15](#)

SW3-4 (DAI19-20) push buttons, [1-15](#),  
[2-11](#), [2-15](#)

SW5 (reset) push button, [2-15](#)

# Index

SW6 (microphone) switch, [1-14](#), [2-9](#)  
SW7 (AD1835A) switch, [2-10](#)  
SW8 (SPI disable) switch, [2-6](#), [2-11](#)  
SW9 (push button enable) DIP switch, [1-3](#),  
[1-14](#), [2-11](#), [2-15](#)  
switches  
    *See also* switches by name (SW<sub>x</sub>)  
    diagram of locations, [2-9](#)  
synchronous random access memory, *See*  
    SRAM  
SYSCCTL register, [1-12](#), [1-15](#)  
system architecture, of this EZ-KIT Lite,  
    [2-2](#)

## T

technical support, [xiv](#)  
time-division multiplexed (TDM) mode,  
    [1-13](#)

## U

U24, LED latch, [2-11](#)  
USB  
    cable, [1-2](#), [2-14](#)  
    connector (ZJ1), [2-20](#)  
    interface, [2-8](#), [2-21](#)  
    monitor LED (ZLED3), [2-14](#)

## V

VisualDSP++ environment, [1-9](#)  
voltage planes, [2-2](#)

## W

$\overline{WE}$  signals, [2-11](#)