

## Using the **EVAL-3CH4CHSOICEBZ** *i*Coupler Data Isolator Evaluation Board

### FEATURES

- Access to all 4 data channels
- Enable/disable controls
- Multiple connection options
- Support for active probes
- Provision for cable terminations
- Support for printed circuit board (PCB) edge mounted coaxial connectors
- Easy configuration
- Sample *i*Coupler digital isolator must be ordered separately

### SUPPORTED *i*Coupler GENERICS

- [ADuM130D/ADuM130E/ADuM131D/ADuM131E](#)
- [ADuM140D/ADuM140E/ADuM141D/ADuM141E/ADuM142D/ADuM142E](#)
- [ADuM230D/ADuM230E/ADuM231D/ADuM231E](#)
- [ADuM240D/ADuM240E/ADuM241D/ADuM241E/ADuM242D/ADuM242E](#)

### EVALUATION BOARD PHOTOGRAPH

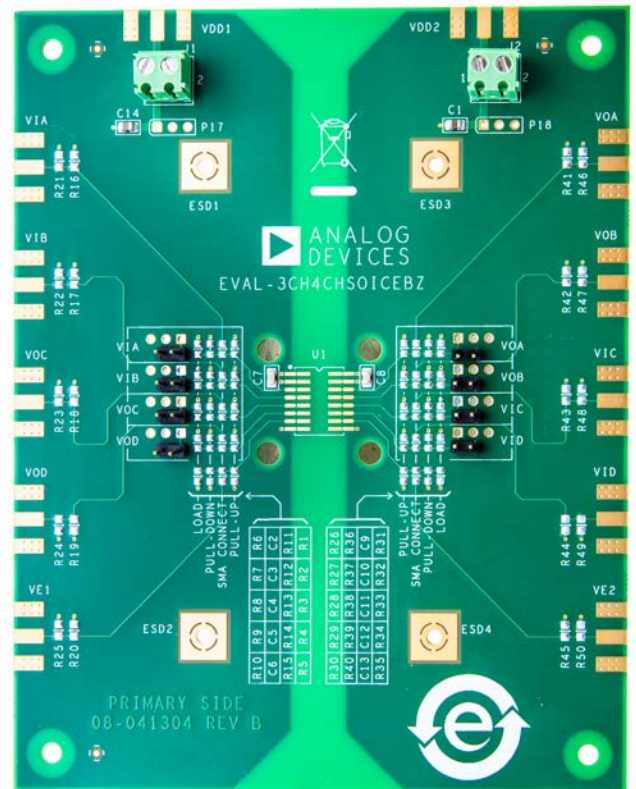

Figure 1.

### GENERAL DESCRIPTION

The **EVAL-3CH4CHSOICEBZ** evaluation board supports triple- and quad-channel standard data isolators in 16-lead SOIC packages. The evaluation board provides a JEDEC standard 16-lead SOIC\_N and SOIC\_W pad layout and routing appropriate for the evaluation of supported devices. The evaluation board provides a connection to power supplies by screw terminals and includes optimal bypass capacitors. Signal channel routing supports signal distribution and loopback, and provides positions for loads referenced to the VDD1/VDD2 and GND1/GND2 planes. Signal sources can be conducted to the board through header pins or edge mounted SMA connectors; SMA connectors must be ordered separately. Positions for through hole 0.2 inch headers compatible with active probes are provided on the PCB; probe header pins must be ordered separately.

The board follows PCB design practices for 4-layer boards, including a full power and ground plane on each side of the isolation barrier. No other electromagnetic interference (EMI) or noise mitigation design features are included on the board. In cases of very high speed operation or when ultralow emissions are required, refer to the [AN-1109](#) application note for additional board layout techniques.

Full specifications for the device under test (DUT) are available in the corresponding product data sheet, which should be consulted in conjunction with this user guide when using the evaluation board.

**TABLE OF CONTENTS**

Features ..... 1

Supported *i*Coupler Generics ..... 1

Evaluation Board Photograph..... 1

General Description ..... 1

Revision History ..... 2

Evaluation Board Circuitry ..... 3

    PCB Evaluation Functions ..... 3

    Connectors ..... 3

Power Input .....3

Data Input/Output Structures .....3

Bypass on the PCB .....4

High Voltage Capability .....4

Evaluation Board Schematics and Artwork .....5

Ordering Information .....9

    Bill of Materials.....9

**REVISION HISTORY**

**12/2016—Rev. 0 to Rev. A**

Changes to Supported *i*Coupler Generics Section..... 1

Moved Figure 1 ..... 1

Changes to Figure 1 ..... 1

Changes to PCB Evaluation Functions Section, Connectors  
Section, and Data Input/Output Structures Section..... 3

Deleted Figure 2; Renumbered Sequentially .....4

Changes to Bypass on the PCB Section .....4

Change to Figure 5 .....5

**5/2016—Revision 0: Initial Version**

## EVALUATION BOARD CIRCUITRY

### PCB EVALUATION FUNCTIONS

The EVAL-3CH4CHSOICEBZ board evaluates the full range of iCoupler® data transfer functions, powers each side of the iCoupler isolator independently, and applies high differential voltages between the two sides of the isolator. The board is intended for evaluation of the components, but has not been safety certified for high voltage operation. If differential voltages greater than 60 V are applied, external safety measures appropriate for the voltage must be in place.

The evaluation board comes with power terminals, bypass capacitors, and header pins installed. The compatible iCoupler digital isolator must be ordered and installed separately. The EVAL-3CH4CHSOICEBZ is compatible with triple- and quad-channel iCoupler standard data isolator devices with on-off keying architecture, such as the ADuM130D/ADuM130E/ADuM131D/ADuM131E and ADuM140D/ADuM140E/ADuM141D/ADuM141E/ADuM142D/ADuM142E in 16-lead SOIC\_W and 16-lead SOIC\_N packages.

### CONNECTORS

The PCB provides support for three types of interconnections:

- SMA edge mounted connectors
- Through hole signal ground pairs
- Terminal blocks for power connections

With these three options, it is possible to make temporary and permanent connections to the board.

When coaxial connections are required, SMA connector positions are available for digital input and output signals and VDD1 and VDD2 power supplies. The SMA connector positions must be ordered from a distributor separately. Figure 2 shows examples of installed SMA connectors; these connectors are not only low profile and provide excellent mechanical connections to the PCB, but also support 50  $\Omega$  coaxial cabling.

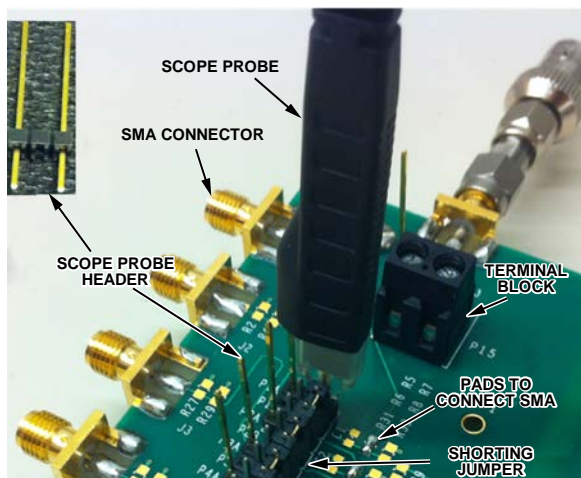

Figure 2. Optional Components

Power can be connected through the J1 and J2 (Terminal 1 is power, Terminal 2 is GND, as marked on the silkscreen in Figure 1) terminal blocks or the optional VDD1 and VDD2 SMA connectors. Signals can be routed in or out of the board with the provided header pins or optional SMA connectors. The pin spacing of each through hole connector is 0.1 inch between centers. There are additional signal test points with 0.2 inch spacing provided for active scope probes. These header pins must be added separately. Installed probe points are shown in Figure 2.

### POWER INPUT

Each side of the iCoupler standard data isolator requires an off-board power source. The power source must be independent if common-mode voltages are applied across the isolation barrier, or damage may occur to the power supply.

Divided power and ground planes are present on Layer 2 and Layer 3 of the PCB on each side of the isolation barrier shown in Figure 6 and Figure 7. Power connects to VDD1 for Side 1 and to VDD2 for Side 2.

### DATA INPUT/OUTPUT STRUCTURES

Each data channel has a variety of structures to configure, load, and monitor both the input and output. Figure 3 shows an example of the routing from an external connection to a DUT data channel. Each data channel has similar connections available.

Starting at the external connection, the signal path is constructed as follows, corresponding with Label 1 through Label 7 in Figure 3:

- A pad layout for a PCB board, edge-mounted SMA connector.
- Two 0805 pads are provided where 100  $\Omega$  resistors to ground can be installed. The combined resistance is 50  $\Omega$  to provide a termination for a standard coaxial cable.
- A standard 0805 pad layout where the coaxial and termination structures can connect to the rest of the signal path.
- A 0603 pad layout between the signal path and the VDD1/VDD2 plane for a pull-up resistor.
- A populated 2-pin header provides a signal ground pair that can be used for clip leads or shorting a channel to ground temporarily.
- There are groupings of three open through holes, consisting of a signal and two ground connections. Use these holes for hardwiring signal wires into the PCB, installing a header to accept an active probe, or installing a 2-pin header to allow adjacent channels to temporarily be shorted together.
- A 0805 pad layout between the signal and ground where a load capacitor or resistor can be installed.

Figure 2 shows many of the optional components installed as well as how jumpers can temporarily connect channels. Figure 2 shows a signal connecting to the first-channel SMA and fanning out to the top three channels, monitored by an active scope probe.

**BYPASS ON THE PCB**

Optional surface-mount bulk capacitors, C1 and C14, are installed near the power connectors to compensate for long cables to the power supply. Bypass capacitors, C7 and C8, are installed near the iCoupler isolator and consist of a 0.1  $\mu$ F capacitor for both DUT power supply pins.

**HIGH VOLTAGE CAPABILITY**

The PCB is designed in adherence with 2500 V basic insulation practices. High voltage testing beyond 2500 V is not recommended. Do not rely on the evaluation board for safety functions.

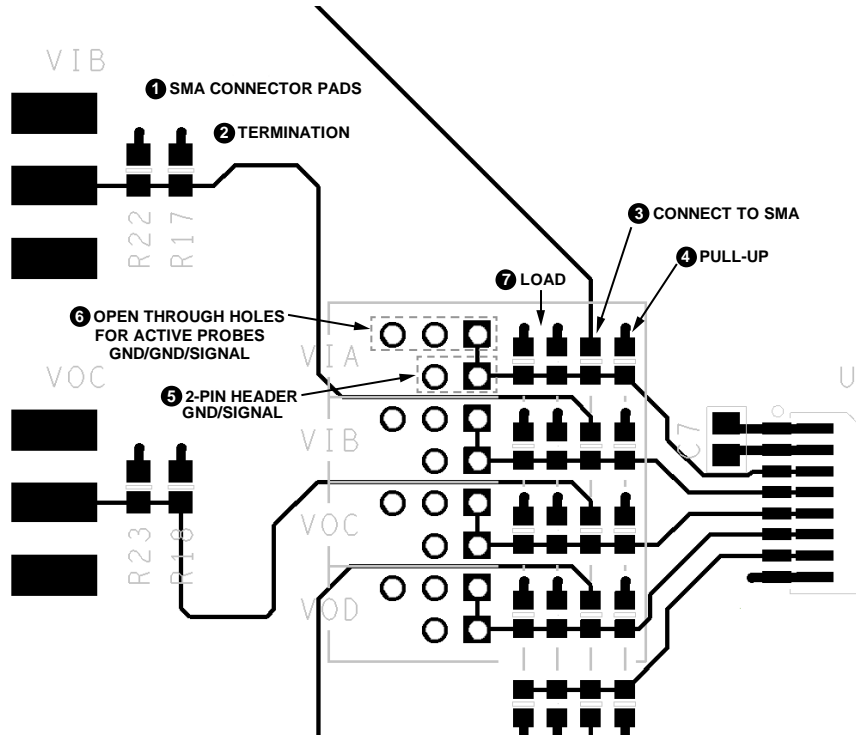

Figure 3. Configuration and Monitoring Structures (Showing a Dataphath from an External Connection to the DUT Pin)

14276-004

EVALUATION BOARD SCHEMATICS AND ARTWORK

14276-005

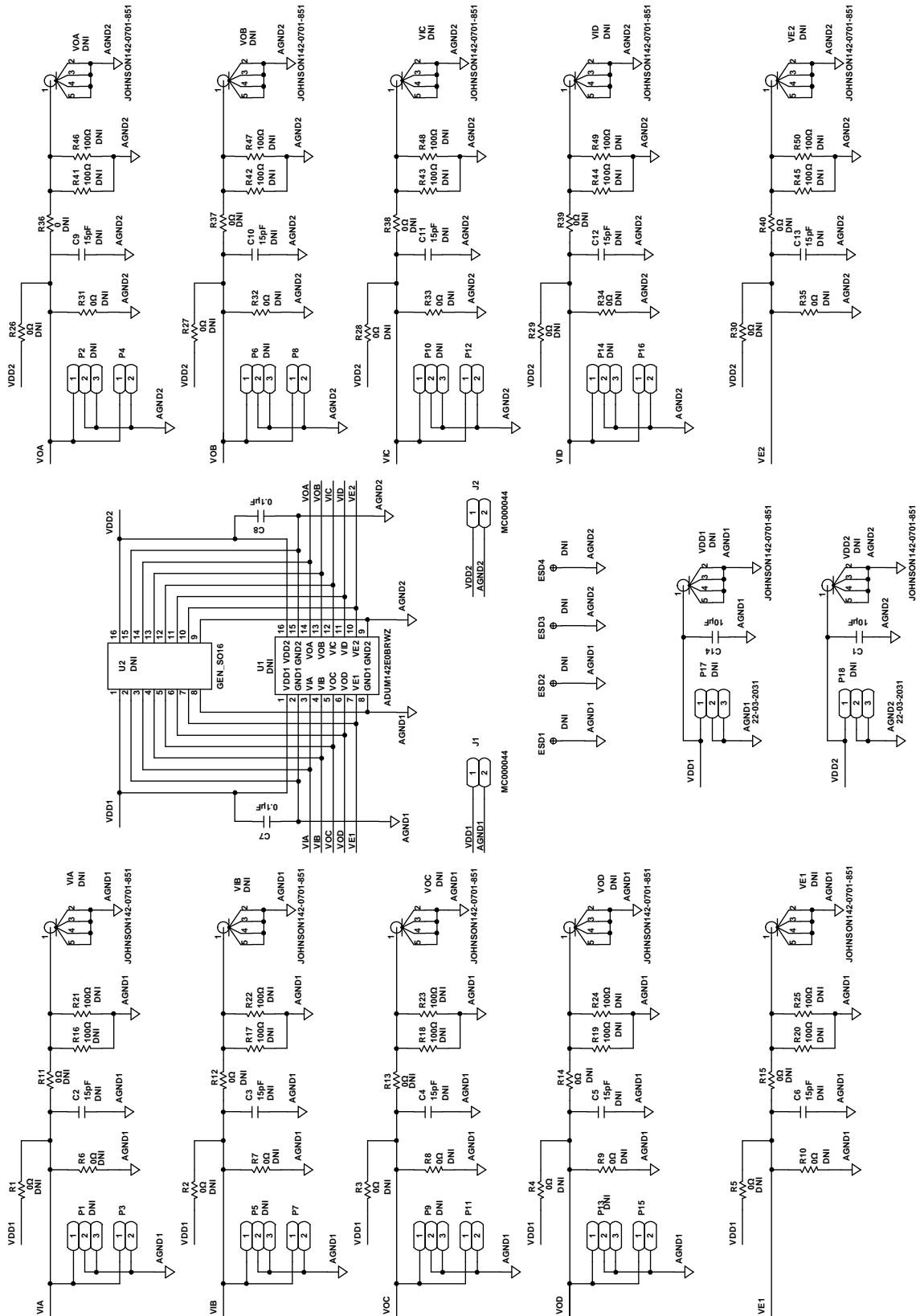
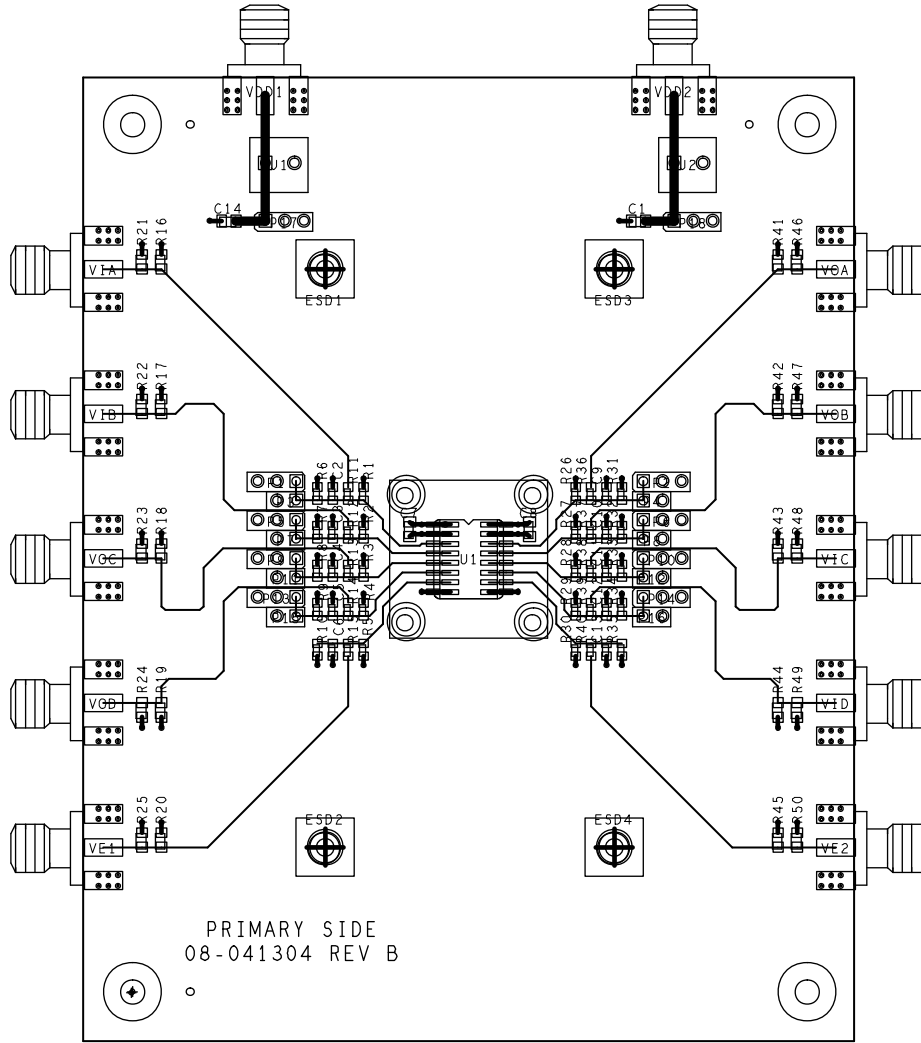

Figure 4. EVAL-3CH4CHSOICEBZ Evaluation Board Schematic



14276-006

Figure 5. Top Level Signal Routing and Assembly

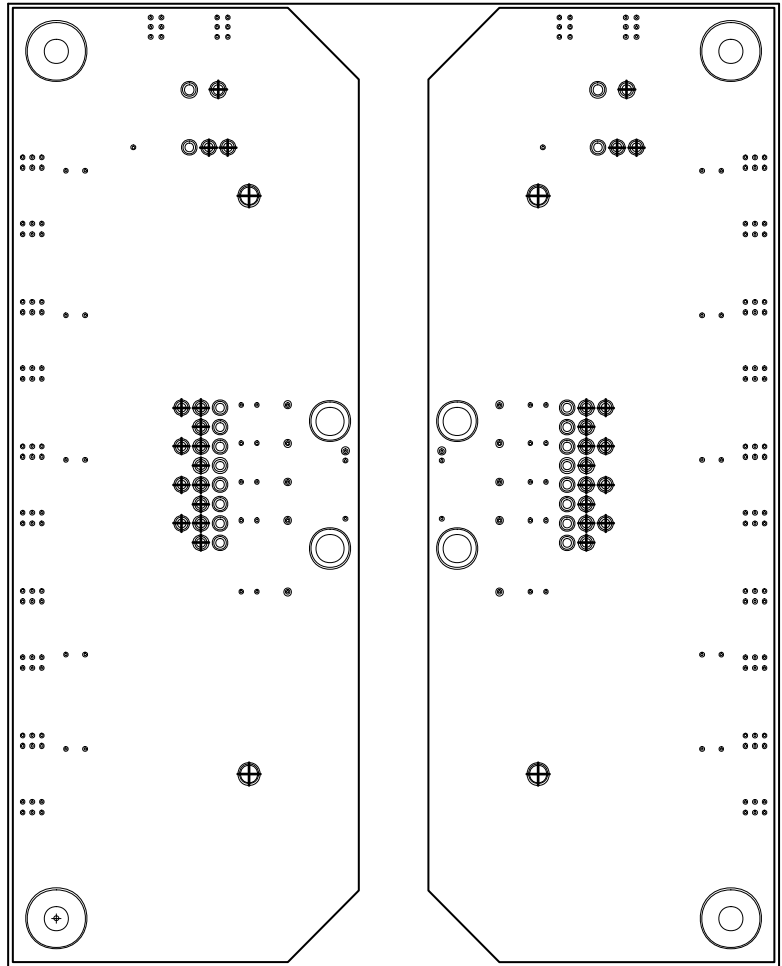
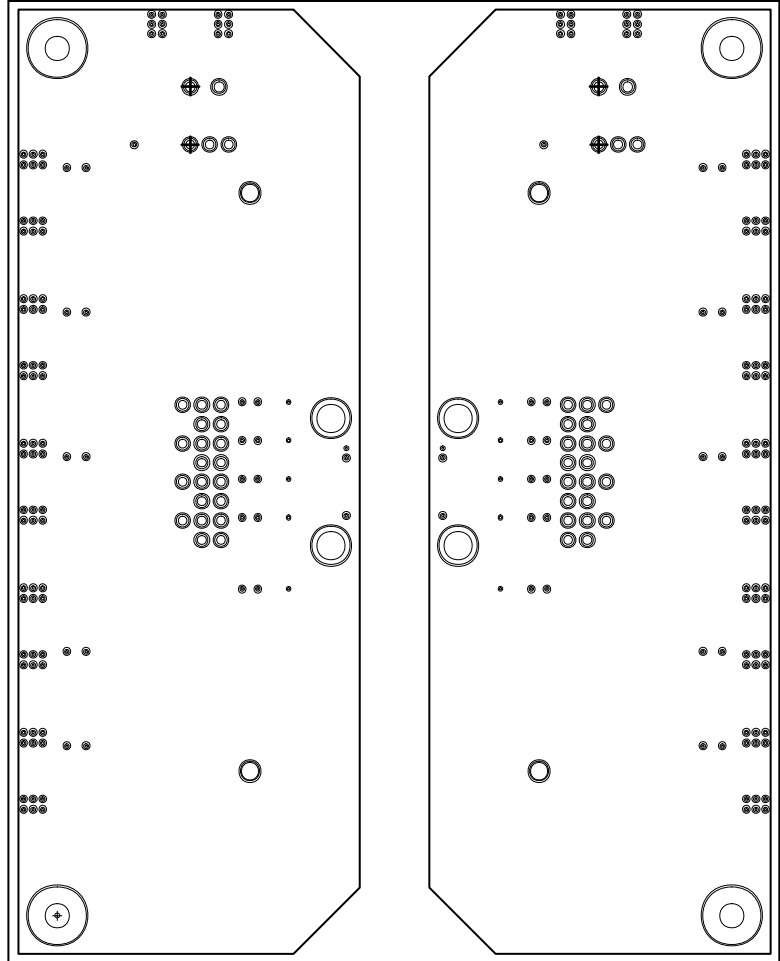

Figure 6. GND1 and GND2 Planes



14275-008

Figure 7. VDD1 and VDD2 Planes



# ORDERING INFORMATION

## BILL OF MATERIALS

Table 1.

Qty	Reference Designator	Description	Part Number/Manufacturer
0	U1	Triple-/quad-channel digital isolator (not installed)	Analog Devices, Inc.
2	C1, C14	0805, 10 µF, ceramic capacitors	Not applicable
2	C7, C8	0805, 0.1 µF, bypass capacitors	Not applicable
2	J1, J2	Screw terminal blocks	Multicomp/MC000044
8	P3, P4, P7, P8, P11, P12, P15, P16	2-pin headers, 0.1 inch spacing	Not applicable
12	VE1, VE2, VIA to VID, VOA to VOD, VDD1, VDD2	SMA edge connectors (not installed)	Johnson/142-0701-851
10	C2 to C6, C9 to C13	Data channel load (not installed)	Not applicable
10	P1, P2, P5, P6, P9, P10, P13, P14, P17, P18	2-pin header, 0.2 inch spacing (not installed)	Samtec MTSW-202-12-G-S-730
30	R1 to R15, R26 to R40	0603, 0 Ω, SMA connection resistors (not installed)	Not applicable
20	R16 to R25, R41 to R50	0805, 100 Ω, input signal termination resistors (not installed)	Not applicable



**ESD Caution**

**ESD (electrostatic discharge) sensitive device.** Charged devices and circuit boards can discharge without detection. Although this product features patented or proprietary protection circuitry, damage may occur on devices subjected to high energy ESD. Therefore, proper ESD precautions should be taken to avoid performance degradation or loss of functionality.

**Legal Terms and Conditions**

By using the evaluation board discussed herein (together with any tools, components documentation or support materials, the "Evaluation Board"), you are agreeing to be bound by the terms and conditions set forth below ("Agreement") unless you have purchased the Evaluation Board, in which case the Analog Devices Standard Terms and Conditions of Sale shall govern. Do not use the Evaluation Board until you have read and agreed to the Agreement. Your use of the Evaluation Board shall signify your acceptance of the Agreement. This Agreement is made by and between you ("Customer") and Analog Devices, Inc. ("ADI"), with its principal place of business at One Technology Way, Norwood, MA 02062, USA. Subject to the terms and conditions of the Agreement, ADI hereby grants to Customer a free, limited, personal, temporary, non-exclusive, non-sublicensable, non-transferable license to use the Evaluation Board FOR EVALUATION PURPOSES ONLY. Customer understands and agrees that the Evaluation Board is provided for the sole and exclusive purpose referenced above, and agrees not to use the Evaluation Board for any other purpose. Furthermore, the license granted is expressly made subject to the following additional limitations: Customer shall not (i) rent, lease, display, sell, transfer, assign, sublicense, or distribute the Evaluation Board; and (ii) permit any Third Party to access the Evaluation Board. As used herein, the term "Third Party" includes any entity other than ADI, Customer, their employees, affiliates and in-house consultants. The Evaluation Board is NOT sold to Customer; all rights not expressly granted herein, including ownership of the Evaluation Board, are reserved by ADI. CONFIDENTIALITY. This Agreement and the Evaluation Board shall all be considered the confidential and proprietary information of ADI. Customer may not disclose or transfer any portion of the Evaluation Board to any other party for any reason. Upon discontinuation of use of the Evaluation Board or termination of this Agreement, Customer agrees to promptly return the Evaluation Board to ADI. ADDITIONAL RESTRICTIONS. Customer may not disassemble, decompile or reverse engineer chips on the Evaluation Board. Customer shall inform ADI of any occurred damages or any modifications or alterations it makes to the Evaluation Board, including but not limited to soldering or any other activity that affects the material content of the Evaluation Board. Modifications to the Evaluation Board must comply with applicable law, including but not limited to the RoHS Directive. TERMINATION. ADI may terminate this Agreement at any time upon giving written notice to Customer. Customer agrees to return to ADI the Evaluation Board at that time. LIMITATION OF LIABILITY. THE EVALUATION BOARD PROVIDED HEREUNDER IS PROVIDED "AS IS" AND ADI MAKES NO WARRANTIES OR REPRESENTATIONS OF ANY KIND WITH RESPECT TO IT. ADI SPECIFICALLY DISCLAIMS ANY REPRESENTATIONS, ENDORSEMENTS, GUARANTEES, OR WARRANTIES, EXPRESS OR IMPLIED, RELATED TO THE EVALUATION BOARD INCLUDING, BUT NOT LIMITED TO, THE IMPLIED WARRANTY OF MERCHANTABILITY, TITLE, FITNESS FOR A PARTICULAR PURPOSE OR NON-INFRINGEMENT OF INTELLECTUAL PROPERTY RIGHTS. IN NO EVENT WILL ADI AND ITS LICENSORS BE LIABLE FOR ANY INCIDENTAL, SPECIAL, INDIRECT, OR CONSEQUENTIAL DAMAGES RESULTING FROM CUSTOMER'S POSSESSION OR USE OF THE EVALUATION BOARD, INCLUDING BUT NOT LIMITED TO LOST PROFITS, DELAY COSTS, LABOR COSTS OR LOSS OF GOODWILL. ADI'S TOTAL LIABILITY FROM ANY AND ALL CAUSES SHALL BE LIMITED TO THE AMOUNT OF ONE HUNDRED US DOLLARS (\$100.00). EXPORT. Customer agrees that it will not directly or indirectly export the Evaluation Board to another country, and that it will comply with all applicable United States federal laws and regulations relating to exports. GOVERNING LAW. This Agreement shall be governed by and construed in accordance with the substantive laws of the Commonwealth of Massachusetts (excluding conflict of law rules). Any legal action regarding this Agreement will be heard in the state or federal courts having jurisdiction in Suffolk County, Massachusetts, and Customer hereby submits to the personal jurisdiction and venue of such courts. The United Nations Convention on Contracts for the International Sale of Goods shall not apply to this Agreement and is expressly disclaimed.

©2016 Analog Devices, Inc. All rights reserved. Trademarks and registered trademarks are the property of their respective owners.  
UG14276-0-12/16(A)



www.analog.com