

FEATURES

Main features

- 4-port HDMI Xpressview receiver
- 170 MHz video and graphics digitizer
- Complete 3D comb video decoder
- Stereo audio codec
- High speed serial output (TMDS)

HDMI support

- 3D TV support
- Audio return channel (ARC)
- Extended colorimetry, including sYCC601, Adobe RGB, Adobe YCC 601, and xvYCC extended gamut color

4:1 HDMI 297 MHz receiver

- Fast switching of HDMI ports (Xpressview)
- 3D TV video format support
- HDCP 1.4 support with internal HDCP keys
- Adaptive HDMI equalizer
- Full HDCP repeater support
- S/PDIF interface for 4 single-mode ARC outputs
- Up to 36-bit Deep Color support
- Complete HDMI audio support
- Audio extraction available
- Support for up to 16 VSIs (including THX Media Director™)

High speed serial output (TMDS 297 MHz)

- Full transmitter support including encryption
- Can operate in a transceiver configuration
- Audio insertion available

Video and graphics digitizer

- Digitizes RGB graphics up to 1600 × 1200 at 60 Hz (UXGA)
- SD, ED, and HD TV support up to 1080p at 60 Hz
- Low refresh rates (24 Hz/25 Hz/30 Hz) support for 720p/1080p

13-channel analog video input channels with 2 outputs

3D comb video decoder

- Full NTSC/PAL/SECAM color standards support
- Adaptive 3D comb filter video decoder
- Advanced time-base correction (TBC) with frame synchronization for SD formats
- Complete SCART support
- Advanced VBI data slicer
- IF compensation filters

Audio codec

- 24-bit, 48 kHz stereo codec
- 5-channel stereo analog input mux with a stereo output

General

- Internal EDID RAM for HDMI and graphics
- Dual STDI (standard identification) function support for dual input detection
- Simultaneous analog processing and HDMI monitoring for fast input switching

APPLICATIONS

HDTVs, set-top boxes, AV receivers, projectors, video matrix switchers

FUNCTIONAL BLOCK DIAGRAM

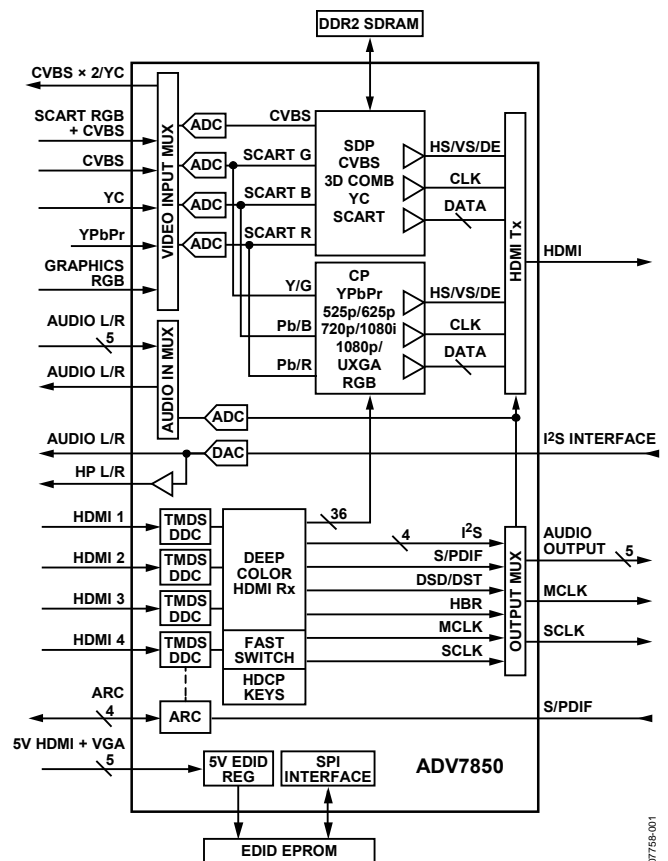

Figure 1.

Rev. 0

Information furnished by Analog Devices is believed to be accurate and reliable. However, no responsibility is assumed by Analog Devices for its use, nor for any infringements of patents or other rights of third parties that may result from its use. Specifications subject to change without notice. No license is granted by implication or otherwise under any patent or patent rights of Analog Devices. Trademarks and registered trademarks are the property of their respective owners.

TABLE OF CONTENTS

Features	1	Power-Up Sequence	24
Applications.....	1	Power-Down Sequence.....	24
Functional Block Diagram	1	Power Supply requirements	24
Revision History	2	Functional Overview.....	25
General Description	3	HDMI Receiver.....	25
Detailed Functional Block Diagram	4	Analog Front End.....	25
Specifications.....	5	Standard Definition Processor	26
Electrical Characteristics	5	Component Processor	26
Power Specifications	6	VBI Data Processor (VDP)	27
Analog Specifications.....	7	TMDS Output.....	27
Video Specifications.....	9	External Memory Requirements.....	27
Timing Characteristics	10	Other Features	27
Timing Diagrams.....	11	Audio Overview.....	28
Absolute Maximum Ratings.....	13	Analog Audio MUX Functionality	28
Package Thermal Performance.....	13	Audio Codec Functionality.....	28
ESD Caution.....	13	Register Map Architecture	29
Pin Configuration and Function Descriptions.....	14	Outline Dimensions	30
Power Supply Sequencing.....	24	Ordering Guide	30

REVISION HISTORY

5/12—Revision 0: Initial Version

GENERAL DESCRIPTION

The [ADV7850](#) is a high quality, single chip, multiformat video decoder graphics digitizer with an integrated 4:1 multiplexed HDMI® receiver.

This multiformat 3D comb filter decoder supports the conversion of PAL, NTSC, and SECAM standards in the form of a composite or an S-Video input signal into a HDMI output stream. SCART and overlay functionality are enabled by the ability of the [ADV7850](#) to process CVBS and standard definition RGB signals simultaneously.

The [ADV7850](#) contains one main component processor (CP) that processes YPrPb and RGB component formats, including RGB graphics. The [ADV7850](#) can operate in quad HDMI and analog input mode, thus allowing for fast switching between the analog video inputs and HDMI.

The [ADV7850](#) supports the decoding of a component RGB/YPrPb video signal into a HDMI output stream. The support for component video includes 525i, 625i, 525p, 625p, 720p, 1080i, 1080p, and 1250i standards, as well as many other SMPTE and HD standards.

The [ADV7850](#) supports graphics digitization. The [ADV7850](#) is capable of digitizing RGB graphics signals from VGA to UXGA rates and converting them into an HDMI output stream. Internal EDID RAM is available for one graphics port.

The [ADV7850](#) incorporates a quad input HDMI-compatible receiver that supports all HDTV formats up to 3D 1080p 60 Hz and 2160P 24 Hz.

The [ADV7850](#) supports full HDCP decryption with internal key storage. The [ADV7850](#) features HDCP authentication on all ports simultaneously. The feature allows fast switching between HDMI ports. Sync measurements and status monitoring are also available for all HDMI ports. Each HDMI port has dedicated 5 V detect and hot plug assert pins. The HDMI receiver

also includes an integrated equalizer that ensures robust operation of the interface with cable lengths up to 30 meters. The HDMI receiver has advanced audio functionality, such as a mute flag, that prevents audible extraneous noise in the audio output.

In addition, the HDMI receiver incorporates internal EDID support, which can be made available in full power, power-down, and power-off modes. An internal regulator supplies external EDID memory from the HDMI 5 V signal in power-off mode.

The [ADV7850](#) incorporates Xpressview™ fast switching on all HDMI input ports. Using the Analog Devices, Inc., hardware-based HDCP engine that minimizes software overhead, Xpressview technology allows fast switching between any two HDMI input ports in less than 1 second.

The [ADV7850](#) offers a flexible audio output port for the audio data decoded from the HDMI stream. HDMI audio formats, including super audio CD (SACD) via DSD, DST, and HBR are supported.

The [ADV7850](#) also features the single mode audio return channel (ARC) feature. ARC simplifies cabling by combining upstream audio capability in a conventional HDMI cable.

The stereo audio ADC converts analog audio inputs and provides the data to the back end via the HDMI interface. The stereo audio DAC receives I²S data from the back end and converts it to analog audio output. The audio output is available as both high impedance and a driven output, which is suitable for driving headphones directly.

Fabricated in an advanced CMOS process, the [ADV7850](#) is provided in a 19 mm × 19 mm, 425-ball, CSP_BGA, surface-mount, RoHS-compliant package, and is specified over the -20°C to +70°C temperature range.

DETAILED FUNCTIONAL BLOCK DIAGRAM

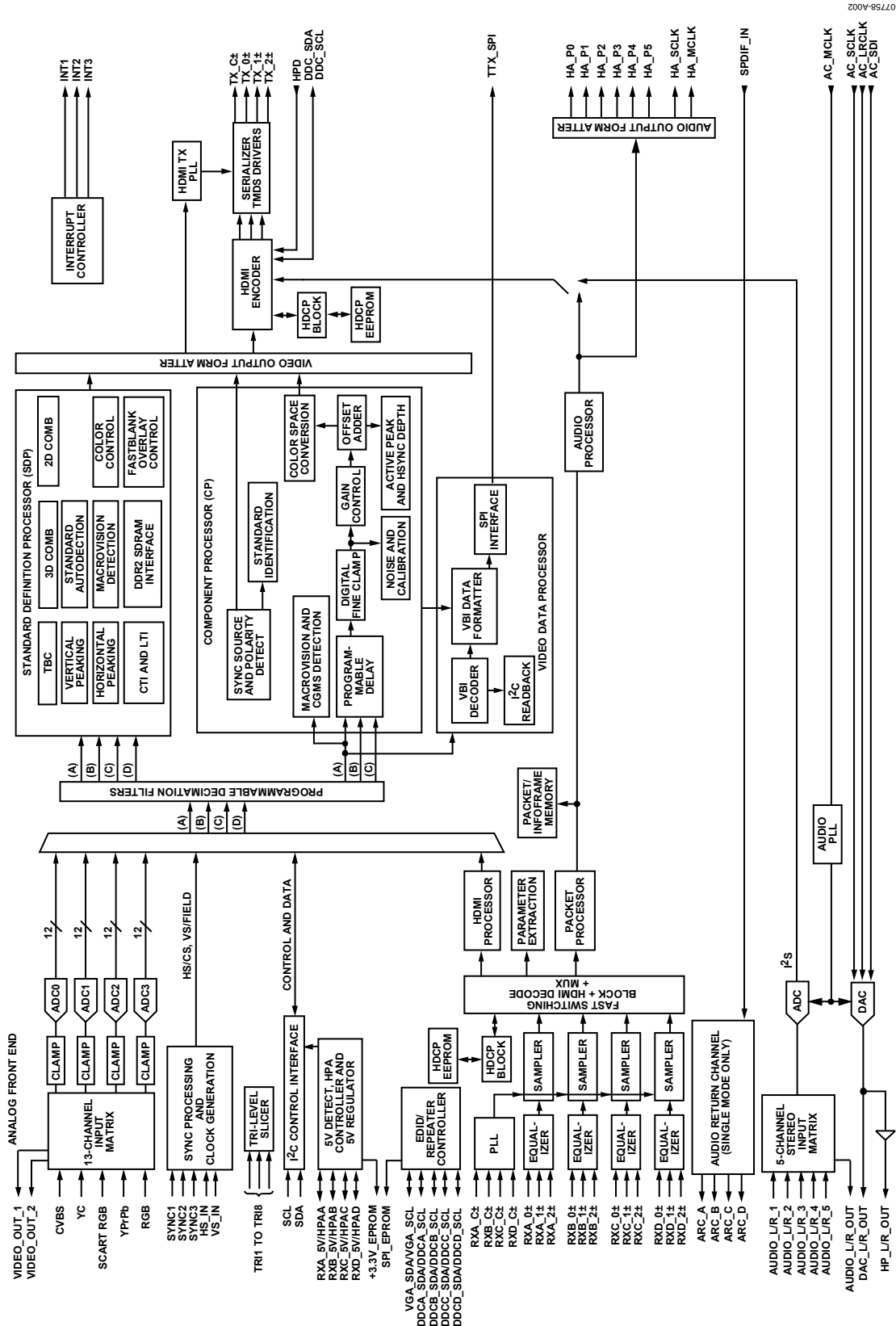

Figure 2. Detailed Functional Block Diagram

SPECIFICATIONS

AVDD = 1.8 V ± 5%, VDD to GND = 1.8 V ± 5%, PVDD = 1.8 V ± 5%, TX_AVDD = 1.8 V ± 5%, TX_PVDD = 1.8 V ± 5%, SAVDD = 1.8 V ± 5%, SDVDD = 1.8 V ± 5%, CVDD = 1.8 V ± 5%, DVDDIO = 3.3 V ± 5%, TX_VDD33 = 3.3 V ± 5%, TVDD = 3.3 V ± 5%, AC_AVDD = 3.3 V ± 5%. T_{MIN} to T_{MAX} = -20°C to +70°C, unless otherwise noted.

ELECTRICAL CHARACTERISTICS

Table 1.

Parameter	Symbol	Test Conditions/Comments	Min	Typ	Max	Unit
STATIC PERFORMANCE						
Resolution (Each ADC)	N				12	Bits
Integral Nonlinearity	INL	27 MHz (at a 12-bit level)		-3.0 to +8.0		LSB
		54 MHz (at a 12-bit level)		-3.0 to +8.0		LSB
		74.25 MHz (at a 12-bit level)		-4.0 to +7.0		LSB
		108 MHz (at a 11-bit level)		-3.5 to +8.0		LSB
		170 MHz (at a 9-bit level)		-0.7 to +1.8		LSB
Differential Nonlinearity	DNL	27 MHz (at a 12-bit level)		-0.7 to +0.8		LSB
		54 MHz (at a 12-bit level)		-0.7 to +0.8		LSB
		75 MHz (at a 12-bit level)		-0.7 to +0.8		LSB
		108 MHz (at a 11-bit level)		-0.7 to +0.8		LSB
		170 MHz (at a 9-bit level)		-0.6 to +0.5		LSB
DIGITAL INPUTS						
Input High Voltage	V _{IH}	XTALN and XTALP pins	1.2			V
Input Low Voltage	V _{IL}	XTALN and XTALP pins			0.4	V
	V _{IH}	Other digital inputs	2			V
Input Capacitance	V _{IL}	Other digital inputs			0.8	V
	C _{IN}				10	pF
HDMI						
TMDs Differential Pin Capacitance				0.3		pF
DIGITAL INPUTS (5 V TOLERANT) ¹						
Input High Voltage	V _{IH}		3.0			V
Input Low Voltage	V _{IL}				0.8	V
Input Current	I _{IN}		-82		+82	μA
DIGITAL OUTPUTS						
Output High Voltage	V _{OH}		2.4			V
Output Low Voltage	V _{OL}				0.4	V
High Impedance Leakage Current	I _{LEAK}	DDC_SCL, DDCA_SDA, DDCB_SCL, DDCB_SDA, DDCC_SCL, DDCC_SDA, DDCD_SCL, DDCD_SDA, VGA_SCL, VGA_SDA, SPDIF_IN, SHARED_EDID		30		μA
	I _{LEAK}	RXA_5V, RXB_5V, RXC_5V, RXD_5V and VGA_5V		20		μA
	I _{LEAK}	All other digital pins		10		μA
Output Capacitance	C _{OUT}				20	pF

¹ The following pins are 5 V tolerant: HS_IN1/TRI7, HS_IN2/TRI5, VS_IN1/TRI8, VS_IN2/TRI6, DDCA_SCL, DDCA_SDA, DDCB_SCL, DDCB_SDA, DDCC_SCL, DDCC_SDA, DDCD_SCL, DDCD_SDA, VGA_SCL, VGA_SDA, TX_DDC_SCL, TX_DDC_SDA, RXA_5V, RXB_5V, RXC_5V, RXD_5V, and VGA_5V.

POWER SPECIFICATIONS

Table 2.

Parameter	Symbol	Min	Typ	Max	Unit	Test Conditions/Comments
POWER REQUIREMENTS						
Digital Core Power Supply	VDD	1.75	1.8	1.85	V	
Digital I/O Power Supply	DVDDIO	3.14	3.3	3.46	V	
Memory Interface Analog Power Supply	SAVDD	1.71	1.8	1.89	V	
Memory Interface Digital Power Supply	SDVDD	1.71	1.8	1.89	V	
DPLL Power Supply	PVDD	1.71	1.8	1.89	V	
Video Analog Power Supply	AVDD	1.71	1.8	1.89	V	
Terminator Power Supply	TVDD	3.14	3.3	3.46	V	
Comparator Power Supply	CVDD	1.71	1.8	1.89	V	
Audio Block Supply	AC_AVDD	3.14	3.3	3.46	V	
HDMI Tx Analog Power Supply	TX_AVDD	1.71	1.8	1.89	V	
HDMI Tx Digital Power Supply	TX_PVDD	1.71	1.8	1.89	V	
HDMI Tx PLL Regulator Power Supply	TX_VDD33	3.14	3.3	3.46	V	
CURRENT CONSUMPTION^{1, 2, 3}						
Digital Core Supply Current	I _{VDD}		400	440	mA	
Digital I/O Supply Current	I _{DVDDIO}		3	4	mA	
DPLL Supply Current	I _{PVDD}		36	45	mA	
Video Analog Supply Current	I _{AVDD}		270	290	mA	
Memory Interface Analog Power Supply	I _{SAVDD}		4	5	mA	
Memory Interface Digital Power Supply	I _{SDVDD}		15	18	mA	
Comparator Supply Current	I _{CVDD}		300	350	mA	
Audio Block Supply Current	I _{AC_AVDD}		80	84	mA	
HDMI Tx Analog Supply Current	I _{TX_AVDD}		20	25	mA	
HDMI Tx Digital Supply Current	I _{TX_PVDD}		43	50	mA	
HDMI Tx PLL Regulator Supply Current	I _{TX_VDD33}		2	5	mA	
Terminator Supply Current ⁴	I _{TVDD}		80	85	mA	One port connected
			280	290	mA	Four ports connected
Power-Down Currents ⁵	I _{VDD}		1		mA	
	I _{DVDDIO}		1.5		mA	
	I _{PVDD}		0.5		mA	
	I _{AVDD}		0.5		mA	
	I _{SAVDD}		0.5		mA	
	I _{SDVDD}		0.5		mA	
	I _{TVDD}		0.5		mA	
	I _{CVDD}		0.5		mA	
	I _{AC_AVDD}		1		mA	
	I _{TX_AVDD}		2.5		mA	
	I _{TX_PVDD}		0.5		mA	
	I _{TX_VDD33}		0.5		mA	
Power-Up Time	t _{PWRUP}		25		ms	

¹ All maximum current values are guaranteed by characterization to assist in power supply design.

² Typical current consumption values are recorded with nominal voltage supply levels, SMPTE bar video pattern, and at room temperature.

³ Maximum current consumption values are recorded with maximum rated voltage supply levels, MoireX video pattern, and at maximum rated temperature.

⁴ Termination power supply includes TVDD current consumed off chip.

⁵ Power-down mode entered by setting the I²C Bit POWER_DOWN high.

ANALOG SPECIFICATIONS

Table 3.

Parameter	Test Conditions/Comments	Min	Typ	Max	Unit
CLAMP CIRCUITRY¹					
Input Impedance	Clamps switched off		10		MΩ
Analog (AIN1 to AIN12)			0.91		V
ADC Midscale (CML)			CML + 0.55		V
ADC Full-Scale Level			CML – 0.55		V
ADC Zero-Scale Level			1.1		V
ADC Dynamic Range			CML – 0.12		V
Clamp Level (When Locked)	Component input, Y signal		CML		V
	Component input, Pr signal		CML		V
	Component input, Pb signal		CML		V
	PC RGB input (R, G, B signals)		CML – 0.12		V
	CVBS input		CML – 0.205		V
	SCART RGB input (R, G, B signals)		CML – 0.205		V
	S-Video input (Y signal)		CML – 0.205		V
	S-Video input (C signal)		CML		V
Large Clamp Source Current	SDP only		0.3		mA
Large Clamp Sink Current	SDP only		0.4		mA
Fine Clamp Source Current	SDP only		9		μA
Fine Clamp Sink Current	SDP only		8		μA
AUDIO ADC SECTION²					
Number of Channels	Stereo pair		1		Channel
Full-Scale Input Level			50		μA rms
Resolution			24		Bits
Dynamic Range (Stereo Channel)					
A-Weighted	–60 dBFS with respect to full-scale analog input		90		dB
Total Harmonic Distortion + Noise (Stereo Channel)	–3 dBFS with respect to full-scale analog input		–85		dB
Gain Mismatch	Left- and right-channel gain mismatch		0.2		dB
Crosstalk (Left to Right, Right to Left)			–90		dB
Gain Error	Input signal = 2.8 V rms		–1.1		dB
Power Supply Rejection	1 kHz, 300 mV p-p signal at AVDD		–89		dB
AUDIO ADC DIGITAL DECIMATOR FILTER CHARACTERISTICS²					
Pass Band	At 48 kHz, guaranteed by design		22.5		kHz
Pass-Band Ripple			±0.0002		dB
Stop Band			26.5		kHz
Stop-Band Attenuation			100		dB
Group Delay			1040		μs
AUDIO DAC SECTION²					
Number of Auxiliary Output Channels	Stereo pair		1		Channel
Resolution			24		Bits
Full-Scale Analog Output			1.0		V rms
Dynamic Range					
A-Weighted	–60 dBFS with respect to full-scale code input		93		dB
Total Harmonic Distortion + Noise	–3 dBFS with respect to full-scale code input		–89		dB

Parameter	Test Conditions/Comments	Min	Typ	Max	Unit
Crosstalk (Left to Right, Right to Left)			-104		dB
Interchannel Gain Mismatch	Left- and right-channel gain mismatch		0.1		dB
Gain Error	1 V rms output		0.525		dB
Power Supply Rejection	1 kHz, 300 mV p-p signal at AVDD		-101		dB
AUDIO DAC DIGITAL INTERPOLATION FILTER CHARACTERISTICS ²	At 48 kHz, guaranteed by design				
Pass Band			21.769		kHz
Pass-Band Ripple			±0.01		dB
Transition Band			23.95		kHz
Stop Band			26.122		kHz
Stop-Band Attenuation			75		dB
Group Delay			580		µs
HEADPHONE AMPLIFIER ²	Measured at headphone output with 32 Ω load				
Number of Channels	Stereo pair		1		Channel
Dynamic Range A-Weighted	-60 dBFS with respect to full-scale code input		92		dB
Total Harmonic Distortion + Noise	-3 dBFS with respect to full-scale code input		-86		dB
Interchannel Gain Mismatch			0.1		dB
Power Supply Rejection	1 kHz, 300 mV p-p signal at AVDD		-82		dB
ANALOG AUDIO MUX ²					
Number of Input Channels	Stereo pair		5		Channel
Number of Output Channels	Stereo pair		1		Channel
Gain Mismatch Between Left and Right Channels			±5		%
REFERENCE SECTION					
Absolute Voltage V_{REF}			1.5		V

¹ Specified for external clamp capacitor of 100 nF.

² Guaranteed by lab characterization.

VIDEO SPECIFICATIONS

Table 4.

Parameter	Symbol	Test Conditions/Comments	Min	Typ	Max	Unit
NONLINEAR SPECIFICATIONS ¹						
Differential Phase	DP	CVBS input (modulated five-step)		0.5		Degrees
Differential Gain	DG	CVBS input (modulated five-step)		0.6		%
Luma Nonlinearity	LNL	CVBS input (modulated five-step)		0.9		%
NOISE SPECIFICATIONS ¹						
SNR Unweighted		Measured at 27 MHz LLC Luma ramp		59		dB
SNR Unweighted		Luma flat field		60		dB
Analog Front-End Crosstalk				60		dB
LOCK TIME SPECIFICATIONS (SDP) ²						
Horizontal Lock Range				±5		%
Vertical Lock Range			40		70	Hz
Subcarrier Lock Range	f_{sc}			±0.8		kHz
Color Lock-In Time				60		Lines
Sync Depth Range			20		200	%
Color Burst Range			1		200	%
Vertical Lock Time				300		ms
Horizontal Lock Time				100		Lines
CHROMA SPECIFICATIONS (SDP) ¹						
Chroma Amplitude Error				0.9		%
Chroma Phase Error				0.3		Degrees
Chroma Luma Intermodulation				0.6		%

¹ Guaranteed by lab characterization.² Guaranteed by design.

TIMING CHARACTERISTICS**Data, SPI, and I²C Timing Characteristics**

Table 5.

Parameter	Symbol	Test Conditions/Comments	Min	Typ	Max	Unit
CLOCK AND CRYSTAL						
Crystal Frequency				27		MHz
Crystal Frequency Stability					±50	ppm
I ² C PORT ¹						
SCL Frequency		See Figure 3			400	kHz
SCL Minimum Pulse Width High	t ₁		600			ns
SCL Minimum Pulse Width Low	t ₂		1.3			µs
Start Condition Hold Time	t ₃		600			ns
Start Condition Setup Time	t ₄		600			ns
SDA Setup Time	t ₅		100			ns
SCL and SDA Rise Time	t ₆				1000	ns
SCL and SDA Fall Time	t ₇				300	ns
Stop Condition Setup Time	t ₈		0.6			µs
RESET FEATURE						
Reset Pulse Width			5			ms
HDMI AUDIO I ² S PORT, MASTER MODE						
HA_SCLK Mark-Space Ratio	t ₁₅ :t ₁₆	See Figure 4	45:55		45:55	% duty cycle
LRCLK ² Data Transition Time	t ₁₇	End of valid data to negative HA_SCLK edge			2	ns
LRCLK ² Data Transition Time	t ₁₈	Negative HA_SCLK edge to start of valid data			2	ns
I2Sx ³ Data Transition Time	t ₁₉	End of valid data to negative HA_SCLK edge			2	ns
I2Sx ³ Data Transition Time	t ₂₀	Negative HA_SCLK edge to start of valid data			2	ns
AUDIO CODEC MASTER CLOCK						
AC_MCLK Frequency Range	f _{MCLK}		4.096		24.576	MHz
AC_MCLK Frequency	f _{MCLK}		128 × f _S			Hz
SPI READ AND WRITE OPERATIONS ¹						
SCL Frequency		See Figure 5, Figure 7, and Figure 8		13.5		MHz
Master Mode						
TTX_SCLK Falling Edge to CS/TTX_MOSI Valid	t ₂₁ , t ₂₂		3.0		4.1	ns
TTX_MISO Setup Time	t ₂₃			15.3		ns
TTX_MISO Hold Time	t ₂₄			2.1		ns
Slave Mode						
CS Falling Edge to TTX_SCLK Rising Edge	t ₂₅ , t ₂₆		4.0			ns
TTX_SCLK Falling Edge to CS Rising Edge	t ₂₇ , t ₂₈		4.0			ns
TTX_MOSI Setup Time	t ₂₉			1.8		ns
TTX_MOSI Hold Time	t ₃₀			2.7		ns
TTX_SCLK Falling Edge to CS/MOSI Valid	t ₃₁ , t ₃₂		7.3		15.5	ns

¹ Guaranteed by design.² LRCLK is a signal accessible via HA_AP5.³ I2Sx are signals accessible via Ball HA_AP1 to Ball HA_AP4.

TIMING DIAGRAMS

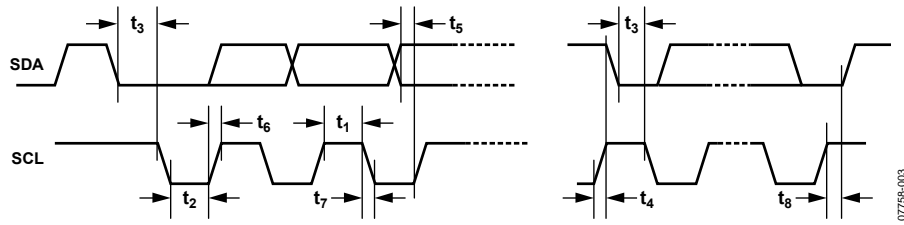
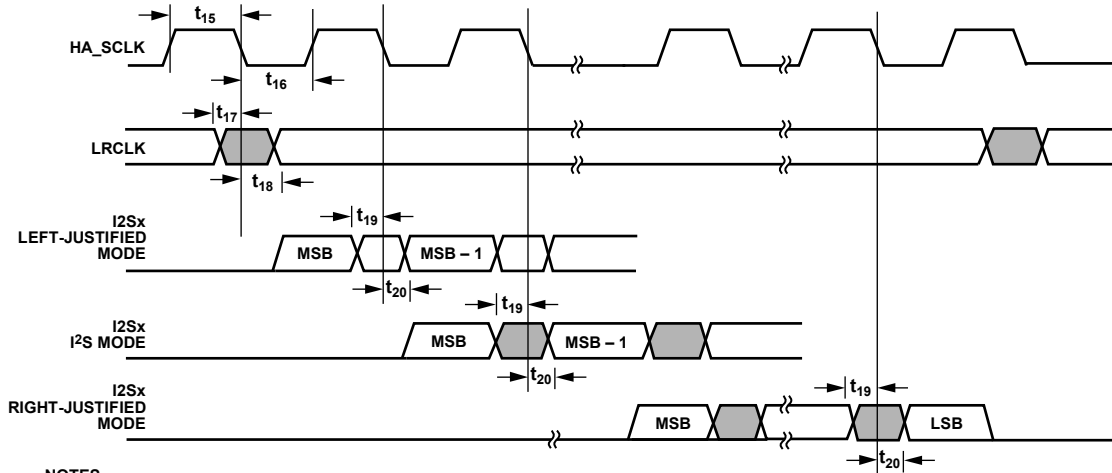

Figure 3. I²C Timing

07758-003



NOTES

1. THE SUFFIX x REFERS TO THE I²S OUTPUT 0, 1, 2, 3.
2. LRCLK IS A SIGNAL ACCESSIBLE VIA HA_AP5 BALL.
3. I2Sx ARE SIGNALS ACCESSIBLE VIA HA_AP1 TO HA_AP4 BALL.

Figure 4. HDMI Audio I²S Timing

07758-004

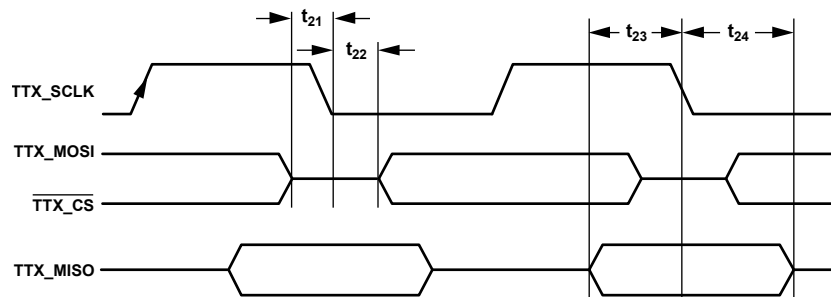

Figure 5. SPI Master Mode Timing

07758-007

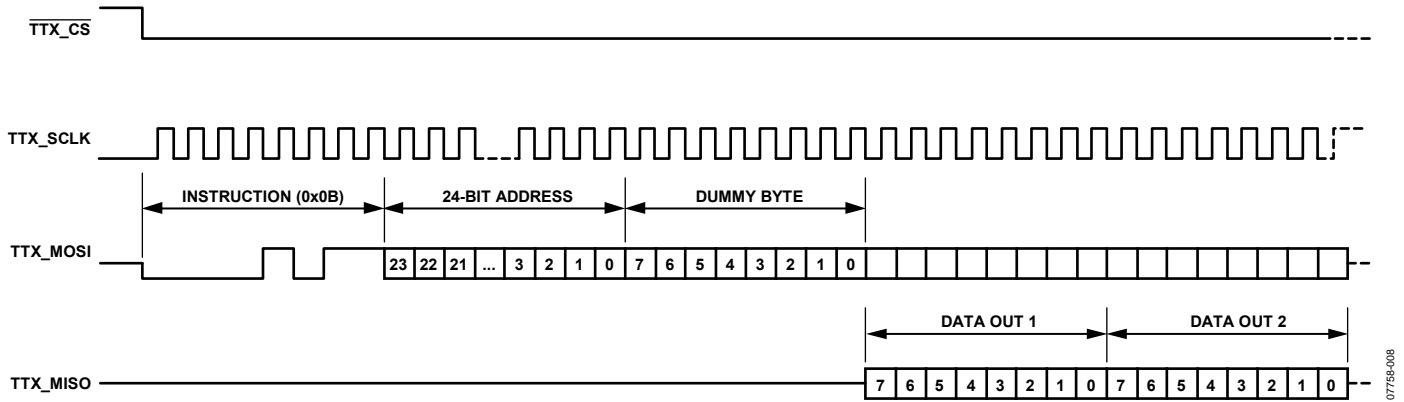

Figure 6. SPI Master Mode Overview

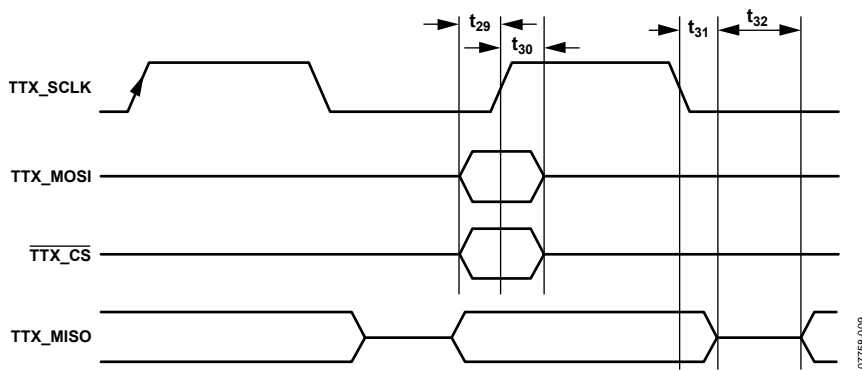

Figure 7. SPI Slave Mode Timing

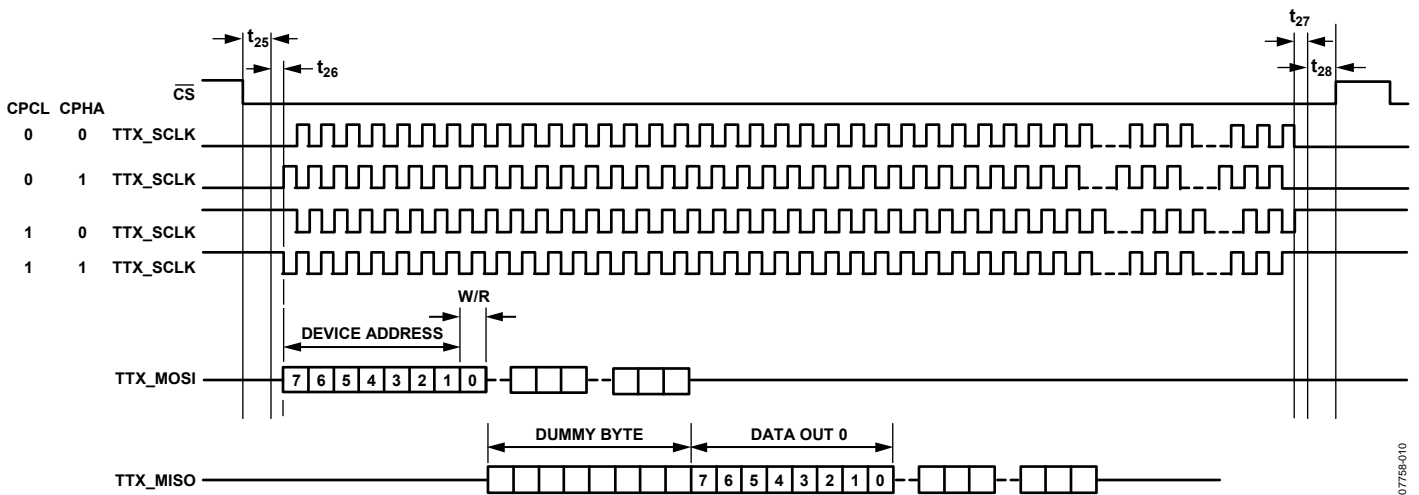

Figure 8. SPI Slave Mode Overview

ABSOLUTE MAXIMUM RATINGS

Table 6.

Parameter	Rating
AVDD to GND	2.2 V
VDD to GND	2.2 V
PVDD to GND	2.2 V
TX_AVDD to GND	2.2 V
TX_PVDD to GND	2.2 V
SAVDD to GND	2.2 V
SDVDD to GND	2.2 V
CVDD to GND	2.2 V
DVDDIO to GND	4.0 V
TVDD to GND	4.0 V
AC_AVDD to GND	4.0 V
Maximum Difference Across All 1.8 V Supplies	-0.3 V to +0.3 V
Maximum Difference Across All 3.3 V Supplies	-0.3 V to +0.3 V
Maximum Difference Between 3.3 V Domain Supplies and 1.8 V Domain Supplies	-0.3 V to +2.2 V
Digital Inputs Voltage to GND	-0.3 V to DVDDIO + 0.3 V
Digital Outputs Voltage to GND	-0.3 V to DVDDIO + 0.3 V
5 V Tolerant Digital Inputs to GND ¹	5.5 V
Analog Inputs to GND	-0.3V to AVDD + 0.3 V -0.3V to AC_AVDD + 0.3 V
XTALN and XTALP to GND	-0.3 V to PVDD + 0.3 V
Maximum Junction Temperature ($T_{J\text{MAX}}$)	125°C
Storage Temperature Range	-65°C to +150°C
Infrared Reflow Soldering (20 sec)	260°C

¹ The following inputs are 3.3 V inputs but are 5 V tolerant: HS_IN1/TRI7, HS_IN2/TRI5, VS_IN1/TRI8, VS_IN2/TRI6, DDCA_SCL, DDCA_SDA, DDCB_SCL, DDCB_SDA, DDCC_SCL, DDCC_SDA, DDCD_SCL, DDCD_SDA, VGA_SCL, VGA_SDA, TX_DDC_SCL, TX_DDC_SDA, RXA_5V, RXB_5V, RXC_5V, RXD_5V and VGA_5V.

Stresses above those listed under Absolute Maximum Ratings may cause permanent damage to the device. This is a stress rating only; functional operation of the device at these or any other conditions above those indicated in the operational section of this specification is not implied. Exposure to absolute maximum rating conditions for extended periods may affect device reliability.

PACKAGE THERMAL PERFORMANCE

To reduce power consumption when using the ADV7850, the user is advised to turn off unused sections of the part.

Due to PCB metal variation, and, therefore, variation in PCB heat conductivity, the value of θ_{JA} may differ for various PCBs.

The most efficient measurement solution is obtained using the package surface temperature to estimate the die temperature because this eliminates the variance associated with the θ_{JA} value.

The maximum junction temperature ($T_{J\text{MAX}}$) of 125°C must not be exceeded. The following equation calculates the junction temperature using the measured package surface temperature and applies only when no heat sink is used on the device under test (DUT):

$$T_J = T_S + (\Psi_{JT} \times W_{TOTAL})$$

where:

T_S is the package surface temperature (°C).

$\Psi_{JT} = 0.7^\circ\text{C}/\text{W}$ for the 425-ball CSP_BGA.

$$W_{TOTAL} = (PVDD \times I_{PVDD}) + (0.4 \times TVDD \times I_{TVDD}) + (CVDD \times I_{CVDD}) + (AVDD \times I_{AVDD}) + (VDD \times I_{VDD}) + (DVDDIO \times I_{DVDDIO}) + (TX_AVDD \times I_{TX_AVDD}) + (TX_PVDD \times I_{TX_PVDD}) + (SAVDD \times I_{SAVDD}) + (SDVDD \times I_{SDVDD}) + (TX_VDD33 \times I_{TX_VDD33}) + (AC_AVDD \times I_{AC_AVDD})$$

where 0.4 reflects the 40% of TVDD power that is dissipated on the part itself.

ESD CAUTION



ESD (electrostatic discharge) sensitive device.

Charged devices and circuit boards can discharge without detection. Although this product features patented or proprietary protection circuitry, damage may occur on devices subjected to high energy ESD. Therefore, proper ESD precautions should be taken to avoid performance degradation or loss of functionality.

PIN CONFIGURATION AND FUNCTION DESCRIPTIONS

	1	2	3	4	5	6	7	8	9	10	11	12	13	14	15	16	17	18	19	20	21	22	23		
A	GND	GND	GND	RXB_2+	RXB_1+	RXB_0+	RXB_C+	ARC_B	TVDD	RXC_2+	RXC_1+	RXC_0+	RXC_C+	ARC_C	GND	RXD_2+	RXD_1+	RXD_0+	RXD_C+	ARC_D	GND	GND	GND	A	
B	ARC_A	HPA_A	GND	RXB_2-	RXB_1-	RXB_0-	RXB_C-	HPA_B	TVDD	RXC_2-	RXC_1-	RXC_0-	RXC_C-	HPA_C	GND	RXD_2-	RXD_1-	RXD_0-	RXD_C-	HPA_D	GND	ACMUXO UT_R	ACMUXO UT_L	B	
C	RXA_C+	RXA_C-	CVDD	GND	GND	GND	GND	VDD_EEP ROM	TVDD	TVDD	TVDD	TVDD	TVDD	TVDD	GND	TVDD	TVDD	TVDD	TVDD	GND	GND	ACMUXIN _1R	ACMUXIN _1L	C	
D	RXA_0+	RXA_0-	CVDD	RXD_5V	VGA_5V	DDCA_SCL	DDCA_SDA	DDCB_SCL	DDCB_SDA	DDCC_SCL	DDCC_SDA	DDCD_SCL	DDCD_SDA	VREG	GND	VGA_SCL	VGA_SDA	TVDD	AC_AVDD	AC_AVDD	AC_AVDD	ACMUXIN _2R	ACMUXIN _2L	D	
E	RXA_1+	RXA_1-	CVDD	RXC_5V																	GND	GND	ACMUXIN _3R	ACMUXIN _3L	E
F	RXA_2+	RXA_2-	CVDD	RXB_5V																	PLL_LF	GND	ACMUXIN _4R	ACMUXIN _4L	F
G	TVDD	TVDD	TVDD	TVDD																	AC_AVDD	GND	ACMUXIN _5R	ACMUXIN _5L	G
H	EP_MISO	EP_MOSI	SPDIF_IN	RXA_5V																	GND	GND	FILTA	VREF_AU DIO	H
J	EP_CS	EP_SCK	SHARED EDID	RESET																	AC_AVDD	GND	ISET	FILTD	J
K	GND	GND	DVDDIO	DVDDIO																	AC_AVDD	AC_AVDD	AC DACOUT R	AC DACOUT L	K
L	HA_AP5	HA_SCLK	INT1	SDA																	AC_AVDD	AC_AVDD	HPOUT_R	HPOUT_L	L
M	HA_AP4	HA_AP3/ INT3	INT2	SCL																	AC_AVDD	GND	GND	GND	M
N	HA_AP2	HA_AP1	AC_MCLK	AC_LRCLK																	PVDD	PVDD	XTALN	XTALP	N
P	HA_AP0	HA_MCLK OUT	AC_SDI	AC_SCLK																	GND	GND	GND	GND	P
R	TTX_SCLK	TTX_MOSI	TTX_MISO	TTX_CS																	GND	GND	REFN	REFP	R
T	DVDDIO	DVDDIO	GND	GND																	AVDD	AVDD	AVDD	AVDD	T
U	TX_AVDD	TX_AVDD	GND	TX_DDC_SCL																	AVIN13	AVIN12	AVIN11	AVIN10	U
V	TX_2+	TX_2-	GND	TX_DDC_SDA																	AVDD	AVDD	AVDD	AVDD	V
W	TX_1+	TX_1-	GND	TX_HPD																	GND	AVOUT2	AVIN9	AVIN8	W
Y	TX_0+	TX_0-	GND	GND	A7	A3	A10	BA0	CKE	GND	DQ6	DQ7	DQ0	DQ8	UDQS	SDVDD	SAVDD	TR1	TR12	GND	AVOUT1	SYNC3	AVIN7	Y	
AA	TX_C+	TX_C-	TX_AVDD	GND	A9	A5	A1	BA1	WE	GND	DQ4	DQ5	DQ2	DQ11	UDQSN	SDVDD	GND	HS_IN1/ TR17	VS_IN1/ TR18	GND	TR13	HS_IN2/ TR15	VS_IN2/ TR16	AA	
AB	GND	TX_PVDD	TX_PLVDD	SDVDD	A11	A6	A2	CAS	RAS	VREF	SDVDD	LQSN	DQ3	DQ10	DQ12	DQ14	GND	SYNC1	AVIN3	GND	SYNC2	AVIN6	TR14	AB	
AC	GND	TX_RTERM	TX_VDD33	SDVDD	A8	A4	A0	CS	CKN	CK	SDVDD	LQSN	DQ1	DQ9	DQ15	DQ13	GND	AVIN1	AVIN2	GND	AVIN4	AVIN5	GND	AC	

Figure 9. Pin Configuration

07758-011

Table 7. Pin Function Descriptions

Pin No.	Mnemonic	Description
A1	GND	Ground.
A2	GND	Ground.
A3	GND	Ground.
A4	RXB_2+	Digital Input Channel 2 True of Port B in the HDMI Interface.
A5	RXB_1+	Digital Input Channel 1 True of Port B in the HDMI Interface.
A6	RXB_0+	Digital Input Channel 0 True of Port B in the HDMI Interface.
A7	RXB_C+	Digital Input Clock True of Port B in the HDMI interface.
A8	ARC_B	Single-Ended Audio Return Channel of Port B in the HDMI Interface.
A9	TVDD	HDMI Termination Supply (3.3 V).
A10	RXC_2+	Digital Input Channel 2 True of Port C in the HDMI Interface.
A11	RXC_1+	Digital Input Channel 1 True of Port C in the HDMI Interface.
A12	RXC_0+	Digital Input Channel 0 True of Port C in the HDMI Interface.
A13	RXC_C+	Digital Input Clock True of Port C in the HDMI Interface.
A14	ARC_C	Single-Ended Audio Return Channel of Port C in the HDMI Interface.
A15	GND	Ground.
A16	RXD_2+	Digital Input Channel 2 True of Port D in the HDMI Interface.
A17	RXD_1+	Digital Input Channel 1 True of Port D in the HDMI Interface.
A18	RXD_0+	Digital Input Channel 0 True of Port D in the HDMI Interface.
A19	RXD_C+	Digital Input Clock True of Port D in the HDMI Interface.
A20	ARC_D	Single-Ended Audio Return Channel of Port D in the HDMI Interface.
A21	GND	Ground.
A22	GND	Ground.
A23	GND	Ground.
B1	ARC_A	Single-Ended Audio Return Channel of Port A in the HDMI Interface.
B2	HPA_A	Hot Plug Assert for Port A.
B3	GND	Ground.
B4	RXB_2–	Digital Input Channel 2 Complement of Port B in the HDMI Interface.
B5	RXB_1–	Digital Input Channel 1 Complement of Port B in the HDMI Interface.
B6	RXB_0–	Digital Input Channel 0 Complement of Port B in the HDMI Interface.
B7	RXB_C–	Digital Input Clock Complement of Port B in the HDMI Interface.
B8	HPA_B	Hot Plug Assert for Port B.
B9	TVDD	HDMI Termination Supply (3.3 V).
B10	RXC_2–	Digital Input Channel 2 Complement of Port C in the HDMI Interface.
B11	RXC_1–	Digital Input Channel 1 Complement of Port C in the HDMI Interface.
B12	RXC_0–	Digital Input Channel 0 Complement of Port C in the HDMI Interface.
B13	RXC_C–	Digital Input Clock Complement of Port C in the HDMI Interface.
B14	HPA_C	Hot Plug Assert for Port C.
B15	GND	Ground.
B16	RXD_2–	Digital Input Channel 2 Complement of Port D in the HDMI Interface.
B17	RXD_1–	Digital Input Channel 1 Complement of Port D in the HDMI Interface.
B18	RXD_0–	Digital Input Channel 0 Complement of Port D in the HDMI Interface.
B19	RXD_C–	Digital Input Clock Complement of Port D in the HDMI Interface.
B20	HPA_D	Hot Plug Assert for Port D.
B21	GND	Ground.
B22	ACMUXOUT_R	Audio Codec Mux Output Right Channel.
B23	ACMUXOUT_L	Audio Codec Mux Output Left Channel.
C1	RXA_C+	Digital Input Clock True of Port A in the HDMI Interface.
C2	RXA_C–	Digital Input Clock Complement of Port A in the HDMI Interface.
C3	CVDD	HDMI Comparator Supply (1.8 V).
C4	GND	Ground.
C5	GND	Ground.
C6	GND	Ground.

Pin No.	Mnemonic	Description
C7	GND	Ground.
C8	VDD_EEPROM	External EDID EEPROM Power Supply.
C9	TVDD	HDMI Termination Supply (3.3 V).
C10	TVDD	HDMI Termination Supply (3.3 V).
C11	TVDD	HDMI Termination Supply (3.3 V).
C12	TVDD	HDMI Termination Supply (3.3 V).
C13	TVDD	HDMI Termination Supply (3.3 V).
C14	TVDD	HDMI Termination Supply (3.3 V).
C15	GND	Ground.
C16	TVDD	HDMI Termination Supply (3.3 V).
C17	TVDD	HDMI Termination Supply (3.3 V).
C18	TVDD	HDMI Termination Supply (3.3 V).
C19	TVDD	HDMI Termination Supply (3.3 V).
C20	GND	Ground.
C21	GND	Ground.
C22	ACMUXIN_1R	Audio Codec Mux Input 1 Right Channel.
C23	ACMUXIN_1L	Audio Codec Mux Input 1 Left Channel.
D1	RXA_0+	Digital Input Channel 0 True of Port A in the HDMI Interface.
D2	RXA_0-	Digital Input Channel 0 Complement of Port A in the HDMI Interface.
D3	CVDD	HDMI Comparator Supply (1.8 V).
D4	RXD_5V	5 V Detect Pin for Port D in the HDMI Interface.
D5	VGA_5V	5 V Detect I/O for VGA Connector.
D6	DDCA_SCL	Serial Clock for DDC Bus of Port A. DDCA_SCL is 5 V tolerant.
D7	DDCA_SDA	Serial Data for DDC Bus of Port A. DDCA_SDA is 5 V tolerant.
D8	DDCB_SCL	Serial Clock Port for DDC Bus of Port B. DDCB_SCL is 5 V tolerant.
D9	DDCB_SDA	Serial Data Port for DDC Bus of Port B. DDCB_SDA is 5 V tolerant.
D10	DDCC_SCL	Serial Clock Port for DDC Bus of Port C. DDCC_SCL is 5 V tolerant.
D11	DDCC_SDA	Serial Data Port for DDC Bus of Port C. DDCC_SDA is 5 V tolerant.
D12	DDCD_SCL	Serial Clock Port for DDC Bus of Port D. DDCD_SCL is 5 V tolerant.
D13	DDCD_SDA	Serial Data Port for DDC Bus of Port D. DDCD_SDA is 5 V tolerant.
D14	VREG	Voltage Regulator Output. Must be decoupled to GND via 1 μ F capacitor.
D15	GND	Ground.
D16	VGA_SCL	Serial Clock for VGA Interface. VGA_SCL is 5 V tolerant.
D17	VGA_SDA	Serial Data for VGA Interface. VGA_SDA is 5 V tolerant.
D18	TVDD	HDMI Termination Supply (3.3 V).
D19	AC_AVDD	Audio Block Supply (3.3 V).
D20	AC_AVDD	Audio Block Supply (3.3 V).
D21	AC_AVDD	Audio Block Supply (3.3 V).
D22	ACMUXIN_2R	Audio Codec Mux Input 2 Right Channel.
D23	ACMUXIN_2L	Audio Codec Mux Input 2 Left Channel.
E1	RXA_1+	Digital Input Channel 1 True of Port A in the HDMI Interface.
E2	RXA_1-	Digital Input Channel 1 Complement of Port A in the HDMI Interface.
E3	CVDD	HDMI Comparator Supply (1.8 V).
E4	RXC_5V	5 V Detect Pin for Port C in the HDMI Interface.
E20	GND	Ground.
E21	GND	Ground.
E22	ACMUXIN_3R	Audio Codec Mux Input 3 Right Channel.
E23	ACMUXIN_3L	Audio Codec Mux Input 3 Left Channel.
F1	RXA_2+	Digital Input Channel 2 True of Port A in the HDMI Interface.
F2	RXA_2-	Digital Input Channel 2 Complement of Port A in the HDMI Interface.
F3	CVDD	HDMI Comparator Supply (1.8 V).
F4	RXB_5V	5 V Detect Pin for Port B in the HDMI Interface.
F20	PLL_LF	Loop Filter Ball for Audio Codec PLL.

Pin No.	Mnemonic	Description
F21	GND	Ground.
F22	ACMUXIN_4R	Audio Codec Mux Input 4 Right Channel.
F23	ACMUXIN_4L	Audio Codec Mux Input 4 Left Channel.
G1	TVDD	HDMI Termination Supply (3.3 V).
G2	TVDD	HDMI Termination Supply (3.3 V).
G3	TVDD	HDMI Termination Supply (3.3 V).
G4	TVDD	HDMI Termination Supply (3.3 V).
G7	GND	Ground.
G8	TEST1	Test Pin. Do not connect.
G9	CVDD	HDMI Comparator Supply (1.8 V).
G10	CVDD	HDMI Comparator Supply (1.8 V).
G11	CVDD	HDMI Comparator Supply (1.8 V).
G12	CVDD	HDMI Comparator Supply (1.8 V).
G13	CVDD	HDMI Comparator Supply (1.8 V).
G14	CVDD	HDMI Comparator Supply (1.8 V).
G15	CVDD	HDMI Comparator Supply (1.8 V).
G16	GND	Ground.
G17	GND	Ground.
G20	AC_AVDD	Audio Block Supply (3.3 V).
G21	GND	Ground.
G22	ACMUXIN_5R	Audio Codec Mux Input 5 Right Channel.
G23	ACMUXIN_5L	Audio Codec Mux Input 5 Left Channel.
H1	EP_MISO	External EDID EEPROM Interface.
H2	EP_MOSI	External EDID EEPROM Interface.
H3	SPDIF_IN	S/PDIF Digital Audio Input for Audio Return Channel (ARC).
H4	RXA_5V	5 V Detect Pin for Port A in the HDMI Interface.
H7	GND	Ground.
H8	GND	Ground.
H9	GND	Ground.
H10	GND	Ground.
H11	GND	Ground.
H12	GND	Ground.
H13	GND	Ground.
H14	GND	Ground.
H15	GND	Ground.
H16	GND	Ground.
H17	GND	Ground.
H20	GND	Ground.
H21	GND	Ground.
H22	FILTA	Audio Codec ADC Filter Capacitor.
H23	VREF_AUDIO	Audio Codec Block Reference Voltage Capacitor.
J1	EP_CS	External EDID EEPROM Interface.
J2	EP_SCK	External EDID EEPROM Interface.
J3	SHARED_EDID	EDID Selection Signal for HDMI Port D.
J4	RESET	Chip Reset. Active low. Minimum low time guarantee reset is 5 ms.
J7	GND	Ground.
J8	GND	Ground.
J9	GND	Ground.
J10	GND	Ground.
J11	GND	Ground.
J12	GND	Ground.
J13	GND	Ground.
J14	GND	Ground.

Pin No.	Mnemonic	Description
J15	GND	Ground.
J16	GND	Ground.
J17	GND	Ground.
J20	AC_AVDD	Audio Block Supply (3.3 V).
J21	GND	Ground.
J22	ISET	Audio Codec ADC Current Settings.
J23	FILTD	Audio Codec DAC Filter Capacitor.
K1	GND	Ground.
K2	GND	Ground.
K3	DVDDIO	I/O Supply (3.3 V).
K4	DVDDIO	I/O Supply (3.3 V).
K7	VDD	Video Digital Supply (1.8 V).
K8	GND	Ground.
K9	GND	Ground.
K10	GND	Ground.
K11	GND	Ground.
K12	GND	Ground.
K13	GND	Ground.
K14	GND	Ground.
K15	GND	Ground.
K16	GND	Ground.
K17	GND	Ground.
K20	AC_AVDD	Audio Block Supply (3.3 V).
K21	AC_AVDD	Audio Block Supply (3.3 V).
K22	AC_DACOUT_R	Audio Codec DAC Output Right Channel.
K23	AC_DACOUT_L	Audio Codec DAC Output Left Channel
L1	HA_AP5	HDMI Audio Port Output.
L2	HA_SCLK	HDMI Audio Port Serial Clock Output.
L3	INT1	External Interrupt 1.
L4	SDA	I ² C Port Serial Data Input/Output.
L7	VDD	Video Digital Supply (1.8 V).
L8	GND	Ground.
L9	GND	Ground.
L10	GND	Ground.
L11	GND	Ground.
L12	GND	Ground.
L13	GND	Ground.
L14	GND	Ground.
L15	GND	Ground.
L16	GND	Ground.
L17	GND	Ground.
L20	AC_AVDD	Audio Block Supply (3.3 V).
L21	AC_AVDD	Audio Block Supply (3.3 V).
L22	HPOUT_R	Headphone Output Right Channel.
L23	HPOUT_L	Headphone Output Left Channel.
M1	HA_AP4	HDMI Audio Port Output.
M2	HA_AP3/INT3	HDMI Audio Port Output/External Interrupt 3. This pin can be configured as a TTL output interrupt pin for the VDP SPI interface.
M3	INT2	External Interrupt 2.
M4	SCL	I ² C Port Serial Clock Input.
M7	VDD	Video Digital Supply (1.8 V).
M8	GND	Ground.
M9	GND	Ground.

Pin No.	Mnemonic	Description
M10	GND	Ground.
M11	GND	Ground.
M12	GND	Ground.
M13	GND	Ground.
M14	GND	Ground.
M15	GND	Ground.
M16	GND	Ground.
M17	GND	Ground.
M20	AC_AVDD	Audio Block Supply (3.3 V).
M21	GND	Ground.
M22	GND	Ground.
M23	GND	Ground.
N1	HA_AP2	HDMI Audio Port Output.
N2	HA_AP1	HDMI Audio Port Output.
N3	AC_MCLK	Audio Codec/DAC Clock Input.
N4	AC_LRCLK	Audio DAC Left/Right Clock Input.
N7	VDD	Video Digital supply (1.8 V).
N8	GND	Ground.
N9	GND	Ground.
N10	GND	Ground.
N11	GND	Ground.
N12	GND	Ground.
N13	GND	Ground.
N14	GND	Ground.
N15	GND	Ground.
N16	GND	Ground.
N17	GND	Ground.
N20	PVDD	DPLL Supply (1.8 V).
N21	PVDD	DPLL Supply (1.8 V).
N22	XTALN	Crystal Output.
N23	XTALP	Crystal Input or External Clock Input.
P1	HA_AP0	HDMI Audio Port Output.
P2	HA_MCLKOUT	HDMI Audio Master Clock Output.
P3	AC_SDI	Audio DAC Data Input.
P4	AC_SCLK	Audio DAC SCLK Input.
P7	VDD	Video Digital Supply (1.8 V).
P8	GND	Ground.
P9	GND	Ground.
P10	GND	Ground.
P11	GND	Ground
P12	GND	Ground
P13	GND	Ground
P14	GND	Ground
P15	GND	Ground
P16	GND	Ground
P17	GND	Ground
P20	GND	Ground
P21	GND	Ground
P22	GND	Ground
P23	GND	Ground
R1	TTX_SCLK	VBI Data Interface.
R2	TTX_MOSI	VBI Data Interface.
R3	TTX_MISO	VBI Data Interface.

Pin No.	Mnemonic	Description
R4	TTX_CS	VBI Data Interface.
R7	VDD	Video Digital Supply (1.8 V).
R8	GND	Ground.
R9	GND	Ground.
R10	GND	Ground.
R11	GND	Ground.
R12	GND	Ground.
R13	GND	Ground.
R14	GND	Ground.
R15	GND	Ground.
R16	GND	Ground.
R17	GND	Ground.
R20	GND	Ground.
R21	GND	Ground.
R22	REFN	Negative Analog Video Reference Output.
R23	REFP	Positive Analog Video Reference Output.
T1	DVDDIO	I/O Supply (3.3 V).
T2	DVDDIO	I/O Supply (3.3 V).
T3	GND	Ground.
T4	GND	Ground.
T7	VDD	Video Digital Supply (1.8 V).
T8	GND	Ground.
T9	GND	Ground.
T10	GND	Ground.
T11	GND	Ground.
T12	GND	Ground.
T13	GND	Ground.
T14	GND	Ground.
T15	GND	Ground.
T16	GND	Ground.
T17	GND	Ground.
T20	AVDD	Video Analog Supply Voltage (1.8 V).
T21	AVDD	Video Analog Supply Voltage (1.8 V).
T22	AVDD	Video Analog Supply Voltage (1.8 V).
T23	AVDD	Video Analog Supply Voltage (1.8 V).
U1	TX_AVDD	HDMI Tx Analog Supply (1.8 V).
U2	TX_AVDD	HDMI Tx Analog Supply (1.8 V).
U3	GND	Ground.
U4	TX_DDC_SCL	Serial Clock for DDC Bus of HDMI Tx. TX_DDCA_SCL is 5 V tolerant.
U7	VDD	Video Digital Supply (1.8 V).
U8	VDD	Video Digital Supply (1.8 V).
U9	VDD	Video Digital Supply (1.8 V).
U10	VDD	Video Digital Supply (1.8 V).
U11	VDD	Video Digital Supply (1.8 V).
U12	VDD	Video Digital Supply (1.8 V).
U13	VDD	Video Digital Supply (1.8 V).
U14	TEST2	Test Pin. Do not connect.
U15	GND	Ground.
U16	GND	Ground.
U17	GND	Ground.
U20	AVIN13	Analog Video Mux Input Channel.
U21	AVIN12	Analog Video Mux Input Channel.
U22	AVIN11	Analog Video Mux Input Channel.

Pin No.	Mnemonic	Description
U23	AVIN10	Analog Video Mux Input Channel.
V1	TX_2+	Digital Output Channel 2 True of the HDMI Tx.
V2	TX_2-	Digital Output Channel 2 Complement of the HDMI Tx.
V3	GND	Ground.
V4	TX_DDC_SDA	Serial Data for DDC Bus of HDMI Tx. TX_DDCA_SDA is 5 V tolerant.
V20	AVDD	Video Analog Supply Voltage (1.8 V).
V21	AVDD	Video Analog Supply Voltage (1.8 V).
V22	AVDD	Video Analog Supply Voltage (1.8 V).
V23	AVDD	Video Analog Supply Voltage (1.8 V).
W1	TX_1+	Digital Output Channel 1 True of the HDMI Tx.
W2	TX_1-	Digital Output Channel 1 Complement of the HDMI Tx.
W3	GND	Ground.
W4	TX_HPD	Hot Plug Detect Signal of the HDMI Tx.
W20	GND	Ground.
W21	AVOUT2	Analog Video Mux Output 2.
W22	AVIN9	Analog Video Mux Input Channel.
W23	AVIN8	Analog Video Mux Input Channel.
Y1	TX_0+	Digital Output Channel 0 True of the HDMI Tx.
Y2	TX_0-	Digital Output Channel 0 Complement of the HDMI Tx.
Y3	GND	Ground.
Y4	GND	Ground.
Y5	A7	SDRAM Address Line.
Y6	A3	SDRAM Address Line.
Y7	A10	SDRAM Address Line.
Y8	BA0	SDRAM Block Address Signal.
Y9	CKE	SDRAM Clock Enable.
Y10	GND	Ground.
Y11	DQ6	SDRAM Data Line.
Y12	DQ7	SDRAM Data Line.
Y13	DQ0	SDRAM Data Line.
Y14	DQ8	SDRAM Data Line.
Y15	UDQS	SDRAM Upper Data Strobe True Signal.
Y16	SDVDD	Memory Interface Supply.
Y17	SAVDD	SDRAM Interface Supply.
Y18	TRI1	Digital Input Capable of Slicing Bilevel or Trilevel Input from SCART or D-Connector.
Y19	TRI2	Digital Input Capable of Slicing Bilevel or Trilevel Input from SCART or D-Connector.
Y20	GND	Ground.
Y21	AVOUT1	Analog Video Mux Output 1.
Y22	SYNC3	This is a synchronization on green or luma input (SOG/SOY) used in embedded synchronization mode.
Y23	AVIN7	Analog Video Mux Input Channel.
AA1	TX_C+	Digital Output Clock True of the HDMI Tx.
AA2	TX_C-	Digital Output Clock Complement of the HDMI Tx.
AA3	TX_AVDD	HDMI Tx Analog Supply (1.8 V).
AA4	GND	Ground.
AA5	A9	SDRAM Address Line.
AA6	A5	SDRAM Address Line.
AA7	A1	SDRAM Address Line.
AA8	BA1	SDRAM Block Address Signal.
AA9	WE	SDRAM Write Enable Signal.
AA10	GND	Ground.
AA11	DQ4	SDRAM Data Line.
AA12	DQ5	SDRAM Data Line.
AA13	DQ2	SDRAM Data Line.

Pin No.	Mnemonic	Description
AA14	DQ11	SDRAM Data Line.
AA15	UDQSN	SDRAM Upper Data Strobe Complement Signal.
AA16	SDVDD	Memory Interface Supply.
AA17	GND	Ground.
AA18	HS_IN1/TRI7	HS on Graphics Port/Digital Input Capable of Slicing Bilevel or Trilevel Input from SCART or D-Connector. The HS input signal is used for 5-wire timing mode. This ball can also be used as a trilevel/bilevel input on the SCART or D-connector.
AA19	VS_IN1/TRI8	VS on Graphics Port/Digital Input Capable of Slicing Bilevel or Trilevel Input from SCART or D-Connector. The VS input signal is used for 5-wire timing mode. This ball can also be used as a trilevel/bilevel input on the SCART or D-connector.
AA20	GND	Ground.
AA21	TRI3	Digital Input Capable of Slicing Bilevel or Trilevel Input from SCART or D-Connector.
AA22	HS_IN2/TRI5	HS on Graphics Port/Digital Input Capable of Slicing Bilevel or Trilevel Input from SCART or D-Connector. The HS input signal is used for 5-wire timing mode. This ball can also be used as a trilevel/bilevel input on the SCART or D-connector.
AA23	VS_IN2/TRI6	HS on Graphics Port/Digital Input Capable of Slicing Bilevel or Trilevel Input from SCART or D-Connector. The VS input signal is used for 5-wire timing mode. This ball can also be used as a trilevel/bilevel input on the SCART or D-connector.
AB1	GND	Ground.
AB2	TX_PVDD	HDMI Tx Digital Supply (1.8 V).
AB3	TX_PLVDD	HDMI Tx PLL Digital Supply (1.8 V). It is important to ensure that this supply pin has a clean voltage input.
AB4	SDVDD	Memory Interface Supply.
AB5	A11	SDRAM Address Line.
AB6	A6	SDRAM Address Line.
AB7	A2	SDRAM Address Line.
AB8	CAS	SDRAM Interface Column Address Select Command Signal. One of four command signals to the external SDRAM.
AB9	RAS	SDRAM Interface Row Address Select Command Signal. One of four command signals to the external SDRAM.
AB10	VREF	Termination Reference Voltage for Memory Interface.
AB11	SDVDD	Memory Interface Supply.
AB12	LDQSN	SDRAM Lower Data Strobe Complement Signal.
AB13	DQ3	SDRAM Data Line.
AB14	DQ10	SDRAM Data Line.
AB15	DQ12	SDRAM Data Line.
AB16	DQ14	SDRAM Data Line.
AB17	GND	Ground.
AB18	SYNC1	This is a synchronization on green or luma input (SOG/SOY) used in embedded synchronization mode.
AB19	AVIN3	Analog Video Mux Input Channel.
AB20	GND	Ground.
AB21	SYNC2	This is a synchronization on green or luma input (SOG/SOY) used in embedded synchronization mode.
AB22	AVIN6	Analog Video Mux Input Channel.
AB23	TRI4	Digital Input Capable of Slicing Bilevel or Trilevel Input from SCART or D-Connector.
AC1	GND	Ground.
AC2	TX_RTERM	This signal sets the internal termination resistance. A 500 Ω resistor between this ball and GND should be used.
AC3	TX_VDD33	HDMI Tx PLL Regulator Supply Input (3.3V). This pin is an internal voltage regulator input.
AC4	SDVDD	Memory Interface Supply.
AC5	A8	SDRAM Address Line.
AC6	A4	SDRAM Address Line.
AC7	A0	SDRAM Address Line.
AC8	\overline{CS}	SDRAM Interface Chip Select. SDRAM \overline{CS} enables and disables the command decoder on the RAM. One of four command signals to the external SDRAM.
AC9	CKN	SDRAM Interface Differential Clock Compliment Output. All address and control output signals to the RAM should be sampled on the positive edge of CK and on the negative edge of CKN.
AC10	CK	SDRAM Interface Differential Clock Right Output. All address and control output signals to the RAM should be sampled on the positive edge of CK and on the negative edge of CKN.

Pin No.	Mnemonic	Description
AC11	SDVDD	Memory Interface Supply.
AC12	LDQS	SDRAM Lower Data Strobe True Signal.
AC13	DQ1	SDRAM Data Line.
AC14	DQ9	SDRAM Data Line.
AC15	DQ15	SDRAM Data Line.
AC16	DQ13	SDRAM Data Line.
AC17	GND	Ground.
AC18	AVIN1	Analog Video Mux Input Channel.
AC19	AVIN2	Analog Video Mux Input Channel.
AC20	GND	Ground.
AC21	AVIN4	Analog Video Mux Input Channel.
AC22	AVIN5	Analog Video Mux Input Channel.
AC23	GND	Ground.

POWER SUPPLY SEQUENCING

POWER-UP SEQUENCE

The recommended power-up sequence of the [ADV7850](#) is as follows:

1. 3.3 V supplies
2. 1.8 V supplies

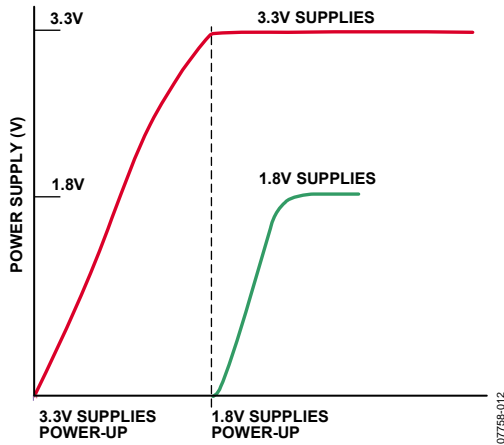

Figure 10. Recommended Power-Up Sequence

Notes

RESET should be held low while the supplies are being powered up.

- 3.3 V supplies should be powered up first.
- 1.8 V supplies should be powered up last.

The [ADV7850](#) can alternatively be powered up by asserting all supplies simultaneously.

In this case, care must be taken to ensure that a lower rated supply does not go above a higher rated supply level as the supplies are being established.

POWER-DOWN SEQUENCE

The [ADV7850](#) supplies can be powered down simultaneously as long as the 3.3 V supply domain does not go below the 1.8 V supply domain.

POWER SUPPLY REQUIREMENTS

Table 8 shows the current rating recommendations for power supply design. These values should be used when designing a power supply section to ensure that an adequate current can be supplied to the [ADV7850](#).

Table 8. Current Rating Recommendation for Power Supply Design

Parameter	Rating
I _{DVDD}	600 mA
I _{CVDD}	450 mA
I _{TVDD}	400 mA
I _{AVDD}	350 mA
I _{AC_AVDD}	150 mA
I _{TX_PVDD}	100 mA
I _{PVDD}	60 mA
I _{TX_VDD33}	50 mA
I _{SDVDD}	50 mA
I _{TX_AVDD}	50 mA
I _{DVDDIO}	20 mA
I _{SAVDD}	20 mA

FUNCTIONAL OVERVIEW

HDMI RECEIVER

The [ADV7850](#) front end incorporates a 4:1 multiplexed HDMI receiver with Xpressview fast switching technology and support for HDMI features including ARC and 3D TV. Building on the feature set of Analog Devices existing HDMI devices, the [ADV7850](#) also offers support for all HDTV formats up to 3D 1080p at 60 Hz and 2160p at 24 Hz. Xpressview fast switching technology, using the Analog Devices hardware-based HDCP engine that minimizes software overhead, allows switching between any two input ports in less than 1 second.

With the inclusion of HDCP 1.4, the [ADV7850](#) can receive encrypted video content. The HDMI interface of the [ADV7850](#) allows for authentication of a video receiver, decryption of encoded data at the receiver, and renewal of that authentication during transmission, as specified by the HDCP 1.4 protocol. Repeater support is also offered by the [ADV7850](#).

The [ADV7850](#) supports the audio return channel feature. There is a dedicated S/PDIF input on which audio can be received for retransmission on the HDMI input. Wide ranges of 3D video formats are supported, including frame packing up to 3D 1080p at 60 Hz and 2160p at 24 Hz.

The HDMI receiver incorporates active equalization of the HDMI data signals. This equalization compensates for the high frequency losses inherent in HDMI and DVI cabling, especially at longer lengths and higher frequencies. It is capable of equalizing for cable lengths up to 30 meters to achieve robust receiver performance at even the highest HDMI data rates.

The HDMI receiver offers advanced audio functionality. It supports multichannel I²S audio for up to eight channels. It also supports a six-DSD channel interface with each channel carrying an oversampled 1-bit representation of the audio signal as delivered on SACD. The [ADV7850](#) can also receive HBR audio packet streams and outputs them through the HBR interface in an S/PDIF format conforming to the IEC 60958 standard.

The receiver contains an audio mute controller that can detect a variety of conditions that may result in audible extraneous noise in the audio output. On detection of these conditions, the audio signal can be muted to prevent audio clicks or pops.

HDMI receiver features include:

- 4:1 multiplexed HDMI receiver
- HDMI, ARC, and 3D format support, DVI 1.0
- 297 MHz HDMI receiver
- Integrated equalizer
- High-bandwidth Digital Content Protection (HDCP 1.4) on background ports
- Internal HDCP keys
- 36-/30-bit Deep Color support
- PCM, HBR, DSD, and DST audio packet support
- Repeater support
- Internal E-EDID RAM
- Hot plug assert output pin for each HDMI port

ANALOG FRONT END

The [ADV7850](#) analog front end comprises four 170 MHz, 12-bit ADCs that digitize the analog video signal before applying it to the standard definition processor (SDP) or component processor (CP).

The front end also includes a 13-channel input mux that enables multiple video signals to be applied to the [ADV7850](#) without the requirement of an external mux.

Current and voltage clamp control loops ensure that any dc offsets are set properly for the video signal. The clamps are positioned in front of each ADC to ensure that the video signal remains within the range of the converter.

The ADCs are configured to run up to 4× oversampling mode when decoding composite, S-Video, or SCART inputs. For component 525i, 625i, 525p, and 625p sources, 4× oversampling is performed. Higher frequency video standards can be 2× or 1× oversampled. Oversampling the video signals reduces the cost and complexity of external antialiasing filters with the benefit of an increased signal-to-noise ratio (SNR).

Optional internal antialiasing filters with programmable bandwidth are positioned in front of each ADC. These filters can be used to band-limit video signals, removing spurious out-of-band noise.

The [ADV7850](#) can support the simultaneous processing of CVBS and RGB standard definition signals to enable SCART compatibility and overlay functionality. A combination of CVBS and RGB inputs can be mixed with the output under the control of I²C registers.

Analog front-end features include:

- Four 170 MHz, 12-bit NSV ADCs that enable 10-bit (SD)/12-bit (CP) video decoding
- 13-channel analog input mux that enables multiple source connections without the requirement of an external mux
- Four current and voltage clamp control loops that ensure any dc offsets are set properly for the video signal
- SCART functionality and SD RGB overlay on CVBS controlled by fastblank input
- SCART source switching detection through the TRI1 to TRI8 inputs
- Four programmable antialiasing filters

STANDARD DEFINITION PROCESSOR

The SDP is capable of decoding a large selection of baseband video signals in composite, S-Video, and 525i/625i component formats. The video standards supported by the SDP include PAL, PAL 60, PAL M, PAL N, PAL NC, NTSC M/J, NTSC 4.43, and SECAM. The [ADV7850](#) can automatically detect the video standard and process it accordingly.

The SDP has a 3D temporal comb filter and a five-line adaptive 2D comb filter that gives superior chrominance and luminance separation when decoding a composite video signal. This highly adaptive filter automatically adjusts its processing mode according to the video standard and signal quality with no user intervention required. The SDP has an IF filter block that compensates for attenuation in the high frequency chroma spectrum due to a tuner SAW filter. The SDP has specific luminance and chrominance parameter controls for brightness, contrast, saturation, and hue.

The [ADV7850](#) implements a patented Adaptive Digital Line Length Tracking (ADLLT™) algorithm to track varying video line lengths from sources such as a VCR. ADLLT enables the [ADV7850](#) to track and decode poor quality video sources (such as VCRs) and noisy sources (such as tuner outputs, VCR players, and camcorders). Frame TBC ensures stable clock synchronization between the decoder and the downstream devices.

The SDP also contains both a luma transient improvement (LTI) block and a chroma transient improvement (CTI) block. These increase the edge rate on the luma and chroma transitions, resulting in a sharper video image.

The SDP has a Macrovision® detection circuit that allows Type I, Type II, and Type III Macrovision protection levels. The decoder is also fully robust to all Macrovision signal inputs.

SDP features include:

- Advanced adaptive 3D comb (using the external DDR2 memory)
- Adaptive 2D five-line comb filters for NTSC and PAL that give superior chrominance and luminance separation for composite video
- Full automatic detection and autoswitching of all worldwide standards (PAL, NTSC, and SECAM)
- Automatic gain control with white peak mode that ensures the video is always processed without loss of the video processing range
- Proprietary architecture for locking to weak, noisy, and unstable sources from VCRs and tuners
- IF filter block that compensates for high frequency luma attenuation due to tuner SAW filter
- LTI and CTI
- Vertical and horizontal programmable luma peaking filters
- 4× oversampling (54 MHz) for CVBS, and S-Video modes
- Free-run output mode that provides stable timing when no video input is present or video lock is lost
- Internal color bar test pattern

- Advanced TBC with frame synchronization, which ensures nominal clock and data for nonstandard input
- Color controls that include hue, brightness, saturation, and contrast

COMPONENT PROCESSOR

The CP section of the [ADV7850](#) is capable of decoding and digitizing a wide range of component video formats in any color space. Component video standards supported by the CP include 525i, 625i, 525p, 625p, 720p, 1080i, 1080p, 1250i, VGA up to UXGA at 60 Hz, and many other standards.

The any-to-any, 3 × 3 CSC matrix is placed between the analog front end and the CP section. This enables YPbPr-to-RGB and RGB-to-YCbCr conversions. Many other standards of color space can be implemented using the color space converter.

The CP section contains circuitry to enable the detection of Macrovision encoded YPbPr signals for 525i, 625i, 525p, and 625p. It is designed to be fully robust when decoding these types of signals.

CP features include:

- 525i, 625i, 525p, 625p, 720p, 1080i, 1080p, and many other HDTV formats are supported
- Supports 720p at 24 Hz/25 Hz formats
- Manual adjustments including gain (contrast), offset (brightness), hue, and saturation
- Support for analog component YPbPr and RGB video formats with embedded synchronization, composite synchronization, or separate HS and VS
- Any-to-any, 3 × 3 CSC matrix that supports YCbCr-to-RGB and RGB-to-YCbCr, fully programmable or preprogrammable configurations
- Synchronization source polarity detector (SSPD) that determines the source and polarity of the synchronization signals that accompany the input video
- Macrovision copy protection detection on component formats (525i, 625i, 525p, and 625p)
- Free-run output mode that provides stable timing when no video input is present or video lock is lost
- Arbitrary pixel sampling support for nonstandard video sources
- 170 MHz conversion rate, which supports RGB input resolutions up to 1600 × 1200 at 60 Hz
- Automatic or manual clamp-and-gain controls for graphics modes
- 32-phase ADC DLL that allows optimum pixel clock sampling
- Automatic detection of synchronization source and polarity by SSPD block
- Standard identification enabled by STDI block
- RGB that can be color space converted to YCbCr and decimated to a 4:2:2 format for video-centric back-end IC interfacing

VBI DATA PROCESSOR (VDP)

VBI extraction of Teletext, CC, WSS, CGMS, PDC, UTC, VPS, GEMSTAR, and VITC data is performed by the VBI data processor of the [ADV7850](#) at interlaced, progressive, and high definition scanning rates. The data extracted can be read back over the SPI interface.

TMDS OUTPUT

The [ADV7850](#) incorporates a 297 MHz TMDS output. This interface is designed to connect to any internal IC with an HDMI or DVI input port.

The digital video interface contains an HDMI and a DVI 1.0-compatible transmitter, and supports all HDTV formats up to 3D 1080p at 60 Hz and 2160p at 24 Hz. The [ADV7850](#) transmitter fully supports programmable AVI InfoFrames. With the inclusion of HDCP, the [ADV7850](#) transmitter allows the secure transmission of protected content as specified by the HDCP protocol. The [ADV7850](#) transmitter also fully supports EDID read operations.

The [ADV7850](#) TMDS output supports the audio mode received from the HDMI receiver, that is, PCM, HBR, DSD, and DST.

EXTERNAL MEMORY REQUIREMENTS

The [ADV7850](#) requires an external SDRAM for 3D comb and frame TBC. The [ADV7850](#) supports DDR2 memories.

Double Data Rate 2 (DDR2)

The [ADV7850](#) can use DDR2 external memory to simultaneously provide 3D comb and frame TBC operation.

It requires a minimum memory of 128 Mb with a speed grade of 200 MHz at CAS latency (CL) 3.

The recommended DDR2 memory compatible with the [ADV7850](#) include the MT47H32M16HR-25E:G from Micron Technology, Inc.

OTHER FEATURES

The [ADV7850](#) has one I²C host port interface.

The [ADV7850](#) has two programmable interrupt request output pins, INT1 and INT2. It also features a number of low power modes and a full power-down mode. The [ADV7850](#) contains an internal power regulator to accommodate power-off mode. In this mode, the [ADV7850](#) is powered from the 5 V supply of the HDMI/VGA cable connected to a source device or devices. In this mode, EDID can be read over an HDMI/VGA DDC link.

The [ADV7850](#) is provided in a 19 mm × 19 mm, RoHS-compliant CSP_BGA package and is specified over the -20°C to +70°C temperature range.

For more detailed product information about the [ADV7850](#), contact your local Analog Devices sales office.

AUDIO OVERVIEW

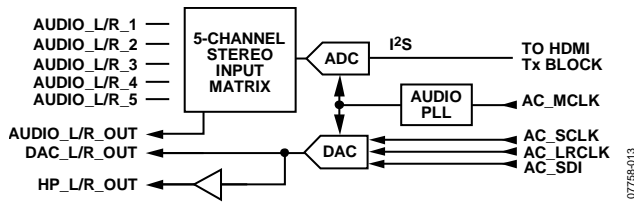

Figure 11. Audio Block

The **ADV7850** supports an audio codec comprising a stereo ADC and a stereo DAC. A 5:1 stereo mux is placed in front of the ADC input. The DAC output is available as a line level output and is passed through an internal headphone amplifier. The integrated headphone amplifier eliminates the need for an external amplifier when driving headphones.

ANALOG AUDIO MUX FUNCTIONALITY

The **ADV7850** has five stereo analog audio inputs and one stereo analog output. Any one of the stereo inputs can be connected to the stereo ADC, and any one of the inputs can be connected to the stereo output. In the case of the analog output, the **ADV7850** also supports mono in-stereo output. The I/O connectivity is shown in Table 9.

Table 9. Analog Audio Inputs to ADC and Analog Audio Outputs Connection Capability

Mux Input	Mux Output		ADC Input	
	Left	Right	Left	Right
1	Left	OK	OK	N/A
	Right	OK	OK	OK
2	Left	OK	OK	N/A
	Right	OK	OK	OK
3	Left	OK	OK	N/A
	Right	OK	OK	OK
4	Left	OK	OK	N/A
	Right	OK	OK	OK
5	Left	OK	OK	N/A
	Right	OK	OK	OK

The **ADV7850** is designed to use a combination of internal and external resistances. Measured from the system audio input connector, the total nominal input impedance is 32.1 kΩ. All analog system audio inputs are designed to support 2.8 V rms audio input. Figure 12 shows a high level overview of the implementation.

The input level at the analog audio input pins on the **ADV7850** is 880 mV rms. However, the **ADV7850** incorporates a gain stage to restore the mux output level to 1.0 V rms. An external line driver is required to restore the audio output signals to the SCART specification of 2.8 V rms. Analog audio mux output signals are inverted with respect to mux input signals.

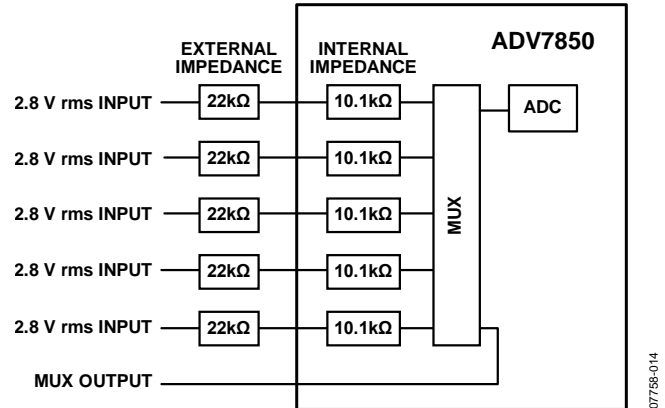

Figure 12. High Level Overview of Analog Audio Input/Output Configuration

A factory calibration is applied during final test to ensure that the gain through the mux circuit remains within ±5%. Calibration is also applied to the ADC reference current to ensure that the code swing from the ADC remains within ±5% across the part for a given input. External impedances with a tolerance of ±1% are required.

AUDIO CODEC FUNCTIONALITY

The **ADV7850** audio codec requires an external MCLK. For MCLK with a frequency of 6.144 MHz, 12.288 MHz, or 24.576 MHz, the ADC and DAC sample rate is 48 kHz. If the MCLK is reduced to 5.6448 MHz, 11.2896 MHz, or 22.5792 MHz, the ADC and DAC sample rate reduces to 44.1 kHz.

The bandwidth of the digital filter is sufficient so that 20 kHz pass band is maintained in this mode. The 32 kHz sampling is also possible but with pass-band reduction.

The system controller must set an I²C control to select the correct mode of operation for the internal PLL so that it always generates an internal MCLK of 6.144 MHz. A fixed oversample rate of 128× is implemented.

The word depth of both the ADC and DAC is 24 bits. The ADC and DAC have independent LRCLK and SCLK signals but use a common MCLK.

The ADC supports I²S mode, providing LRCLK, SCLK, and I²S signals. These signals are sent to the HDMI Tx and embedded into the HDMI stream.

The DAC supports I²S mode. The LRCLK, SCLK, and data signals must be provided by the back-end SOC and must be frequency locked with the MCLK but can be phase independent. The output level is 1 V rms full scale.

There is one stereo headphone amplifier output capable of driving 32 Ω loads at 1 V rms. The headphone output incorporates circuitry to suppress pop/click sounds during power-on/off cycle.

REGISTER MAP ARCHITECTURE

The registers of the ADV7850 are controlled via a 2-wire serial (I²C-compatible) interface. The ADV7850 has 17 maps. The IO map and HDMI Tx map has a static I²C addresses. All other

map addresses must be programmed. This ensures that no address clashes on the system. Figure 13 shows the register map architecture.

Table 5.

Register Map Name	Default Address	Programmable Address	Location at Which Address Can Be Programmed
IO Map	0x40	Not programmable	Not applicable
HDMI Tx Map	0xB8	Not programmable	Not applicable
VDP Map	0x00	Programmable	IO map, Register 0xFE
CP Map	0x00	Programmable	IO map, Register 0xFD
HDMI Rx Map	0x00	Programmable	IO map, Register 0xFB
HDMI Rx EDID Map	0x00	Programmable	IO map, Register 0xFA
KSV Map	0x00	Programmable	IO map, Register 0xF9
AFE Map	0x00	Programmable	IO map, Register 0xF8
InfoFrame Map	0x00	Programmable	IO map, Register 0xF5
SDP_IO Map	0x00	Programmable	IO map, Register 0xF2
SDP Map	0x00	Programmable	IO map, Register 0xF1
HDMI Tx EDID Map	0x00	Programmable	IO map, Register 0xF0
Tx UDP Map	0x00	Programmable	IO map, Register 0xEF
VFE	0x00	Programmable	IO map, Register 0xEC
Memory Map	0x00	Programmable	IO map, Register 0xEB
Audio Codec Map	0x00	Programmable	IO map, Register 0xE7
Tx TEST Map	0x00	Programmable	IO map, Register 0xE3

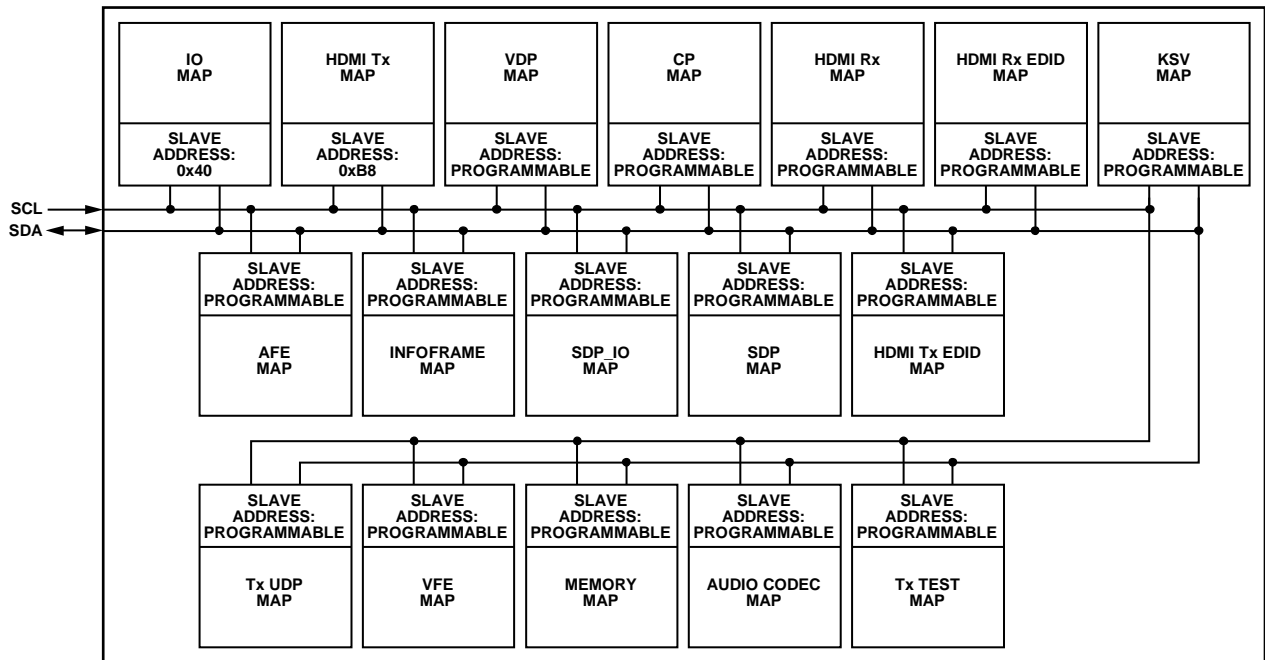
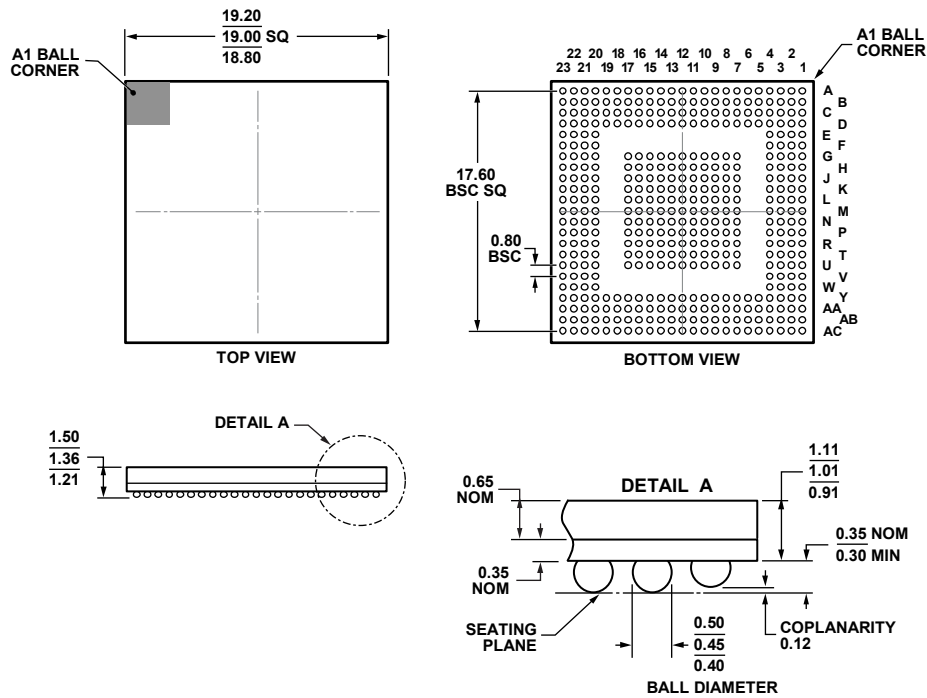

Figure 13. Register Map Architecture

07798-015

OUTLINE DIMENSIONS



COMPLIANT TO JEDEC STANDARDS MO-275-PPAB-2.
 Figure 14. 425-Ball Chip Scale Package Ball Grid Array [CSP_BGA]
 (BC-425-1)
 Dimensions shown in millimeters

11-22-2011-A

ORDERING GUIDE

Model ¹	Notes	Temperature Range	Package Description	Package Option
ADV7850KBCZ-5	2,3	-20°C to +70°C	425-Ball Chip Scale Package Ball Grid Array [CSP_BGA]	BC-425-1
EVAL-ADV7850EBZ	3		Low Cost, Blackfin-Based Evaluation Board with ADV7850 (with HDCP keys)	
EVAL-ADV7850EB1Z	3		ADV7850 Evaluation Board with Complete Audio Support (with HDCP Keys)	

¹ Z = RoHS Compliant Part.

² Speed grade: 5 = 170 MHz.

³ This part is programmed with internal HDCP keys. Customers must have HDCP adopter status (consult Digital Content Protection, LLC, for licensing requirements) to purchase any components with internal HDCP keys.

NOTES

NOTES