

Methods of Measuring Op Amp Settling Time

Jim Williams

Servo, DAC and data acquisition amplifiers all require good dynamic response. In particular, the time required for an amplifier to settle to final value after an input step is especially important. This specification allows setting a circuit's timing margins with confidence that the data produced is accurate. The settling time is the total length of time from input step application until the amplifier remains within a specified error band around the final value.

Figure 1 shows one way to measure amplifier settling time (see References 1, 2, and 3). The circuit uses the "false sum node" technique. The resistors and amplifier form a bridge-type network. Assuming ideal resistors, the amplifier output will step to $-V_{IN}$ when an input pulse is applied. During slew, the oscilloscope probe is bounded by the diodes, limiting voltage excursion. When settling occurs, the oscilloscope probe voltage should be zero. Note that the resistor divider's attenuation means the probe's output will be one-half of the actual settled voltage.

In theory, this circuit allows settling to be observed to small amplitudes. In practice, it cannot be relied upon to produce useful measurements. Several flaws exist. The circuit requires the input pulse to have a flat top within the required measurement limits. Typically, settling within

10mV or less for a 10V step is of interest. No general-purpose pulse generator is meant to hold output amplitude and noise within these limits. Generator output-caused aberration appearing at the oscilloscope probe will be indistinguishable from amplifier output movement, producing unreliable results. The oscilloscope connection presents additional problems. As probe capacitance rises, AC loading of the resistor junction will influence observed settling waveforms. The 20pF probe shown alleviates this problem but its 10X attenuation sacrifices oscilloscope gain. 1X probes are not suitable because of their excessive input capacitance. An active 1X FET probe will work, but another issue remains.

The clamp diodes at the probe point are intended to reduce swing during amplifier slewing, preventing excessive oscilloscope overdrive. Unfortunately, oscilloscope overdrive recovery characteristics vary widely among different types and are not usually specified. The diodes' 600mV drop means the oscilloscope may see an unacceptable overload, bringing displayed results into question (for a discussion of oscilloscope overdrive considerations, see Box Section A, "Evaluating Oscilloscope Overload Response").

LT, LT, LTC, LTM, Linear Technology and the Linear logo are registered trademarks of Linear Technology Corporation. All other trademarks are the property of their respective owners.

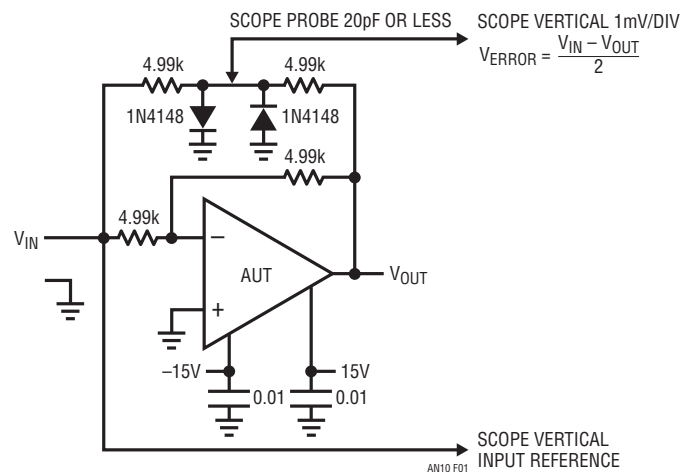

Figure 1. Typical Settling Time Test Circuit

Application Note 10

Figure 2 shows a practical settling time test circuit that addresses the problems discussed. Combined with a careful evaluation of the test oscilloscope used, it permits reliable settling time measurements in the 0.1% to 0.01% region. The input pulse does not drive the amplifier, but switches a Schottky bridge via a clamp. The bridge is biased from two low noise LT1021-10V references. Depending on input pulse polarity, current flows through the appropriate 10k resistor to bias the amplifier's summing point. The bridge switches cleanly and quickly, producing a flat-topped current pulse into the AUT. The circuit's input pulse characteristics do not influence the measurement. A second clamp-bridge arrangement supplies an opposite polarity signal which is nulled against the amplifier's output at point B. Schottky clamp diodes limit this point's voltage excursion to $\pm 300\text{mV}$.

The Q1-Q5 configuration forms a low input capacitance, high speed buffer to drive the oscilloscope. Q1A's 1pF to 2pF input capacitance provides very light AC loading, eliminating probe-caused problems. Q1B, running as a current sink, compensates Q1A's V_{GS} drop. Q2-Q5 form a complementary emitter-follower, which can drive substantial cable capacitance without distortion.

The circuit should be built on a ground planed board with particular care taken to ensure low stray capacitance at points A and B. The AUT socket should be selected for short pin lengths. Very high speed amplifiers ($t_{SETTLE} < 200\text{ns}$) should be directly soldered into the circuit.

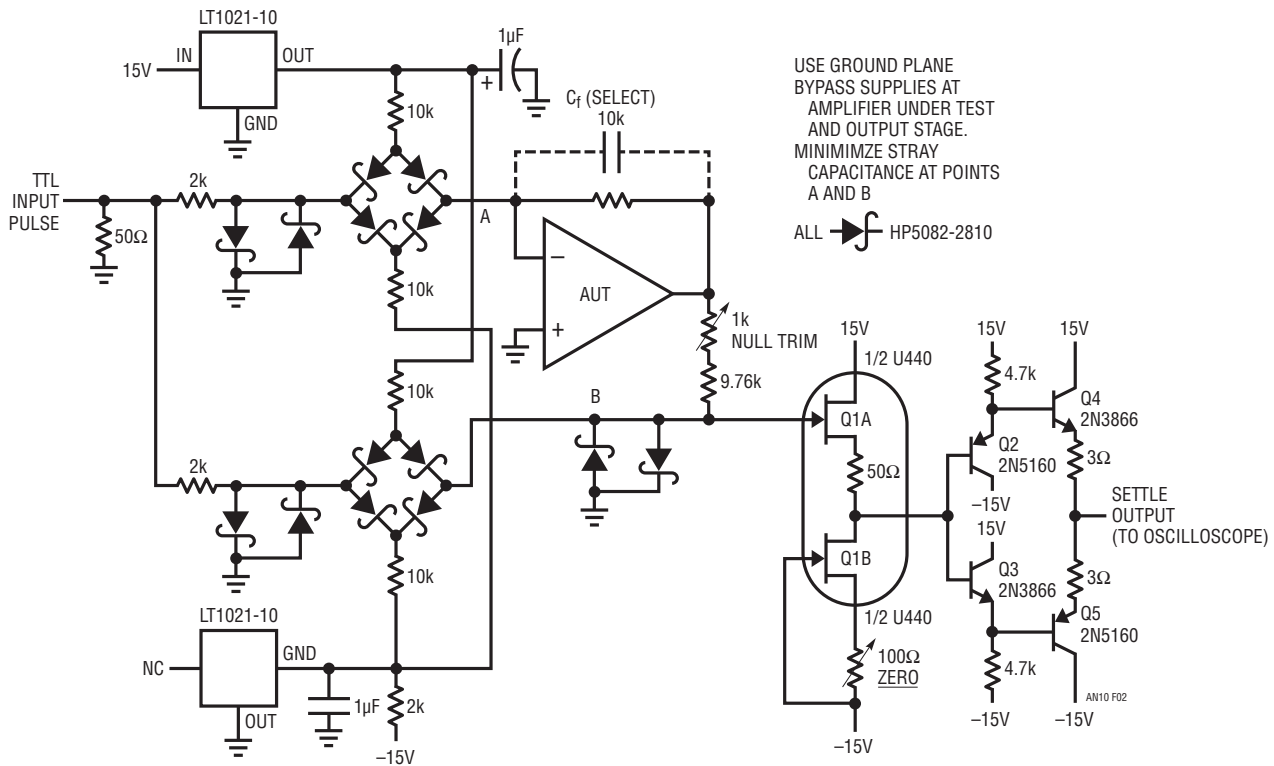

Figure 2. Improved Settling Time Test Circuit

This circuit, combined with a judiciously chosen oscilloscope, allows observation of amplifier settling to a millivolt (0.01%) for a 10V step. A good way to gain confidence in the circuit is to test a very fast UHF amplifier. Figure 3 shows response for an amplifier (Teledyne Philbrick 1435) specified to settle in 70ns within a millivolt for a 10V step. Trace A is the input pulse, Trace B is the amplifier output and Trace C is the settle signal. Settling occurs inside 70ns, indicating good agreement between the circuit and the AUT specification. Since most amplifiers are not nearly this fast, it is reasonable to assume that the circuit will always provide reliable results.

Because this circuit works by nulling opposite polarity sources, it seems unable to test followers—but it can. The AUT is battery-powered and completely floated from the circuit's power supply (Figure 4). The AUT output is connected to circuit ground and the battery center tap becomes the output. The positive input is driven from the Schottky bridge. The floating power supply lets the follower fool the circuit into thinking it is testing an inverter. The AUT's output appears inverted, but this is not a significant penalty.

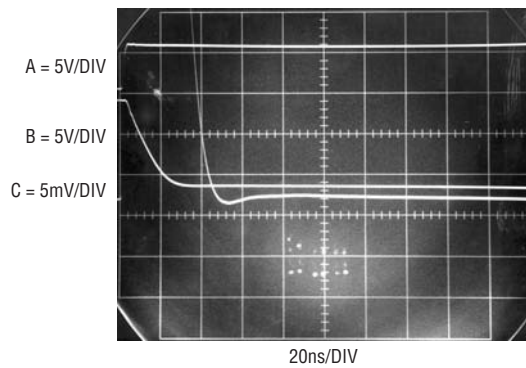

Figure 3. Settling Detail for a Fast Amplifier

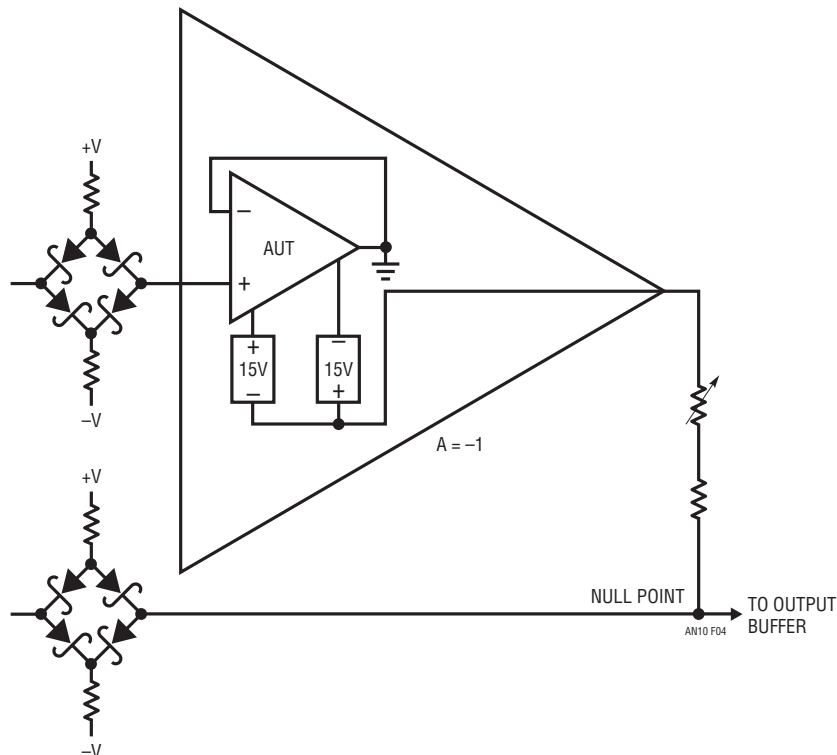

Figure 4. Circuit for Testing Followers

Application Note 10

To calibrate this circuit, ground point B and adjust the “zero trim” for 0V output. Next, temporarily tie the pulse input to +15V through 680Ω and adjust the “null trim” for 0V output. Remove the 680Ω resistor and the circuit is ready for use. When measuring settling times remember to experiment with the value of C_F to obtain best performance (see Box Section B, “Amplifier Compensation”).

In the past, amplifier settling measurements below 1mV were not required. Recently, 16-bit and 18-bit D→A converters have become relatively common, requiring users to consider sub-millivolt settling time performance. Also, the offset specifications of current generation monolithic amplifiers are good enough to make very high precision settling time data worthwhile. Previously, being able to see an amplifier settle within 50μV wasn’t interesting because its thermal drift swamped this figure.

The newer amplifier’s substantially lower drift means very high precision settling time measurement data is useful. Figure 2’s circuit is limited to 0.01% (1mV out of 10V) resolution by the 300mV Schottky clamp potential at point B. Simply increasing oscilloscope gain to get higher resolution will not work because of severe overload problems. With the oscilloscope set at 50μV/division, the

Schottky bound allows a 6000:1 overdrive. This is much more than any vertical amplifier is designed to accommodate. The oscilloscope’s overload recovery will completely dominate the observed waveform and all measurements will be meaningless.

One way to obtain higher precision settling time measurements is to clip the incoming waveform in *time*, as well as amplitude. If the oscilloscope is prevented from seeing the waveform until settling is nearly complete, overload is avoided. Doing this requires placing a switch at the settle circuit’s output and controlling it with an input-triggered, variable delay. FET switches are not suitable because of their gate-source capacitance. This capacitance will allow gate drive artifacts to corrupt the oscilloscope display, producing confusing readings. In the worst case, gate drive transients will be large enough to induce overload, defeating the switch’s purpose.

Figure 5 shows a way to implement the switch, which largely eliminates these problems. This circuit, connected to the basic settle circuit of Figure 2, allows settling within 10μV to be observed. The Schottkys sampling bridge is the actual switch. The bridge’s inherent balance, combined with matched diodes and very high speed complementary

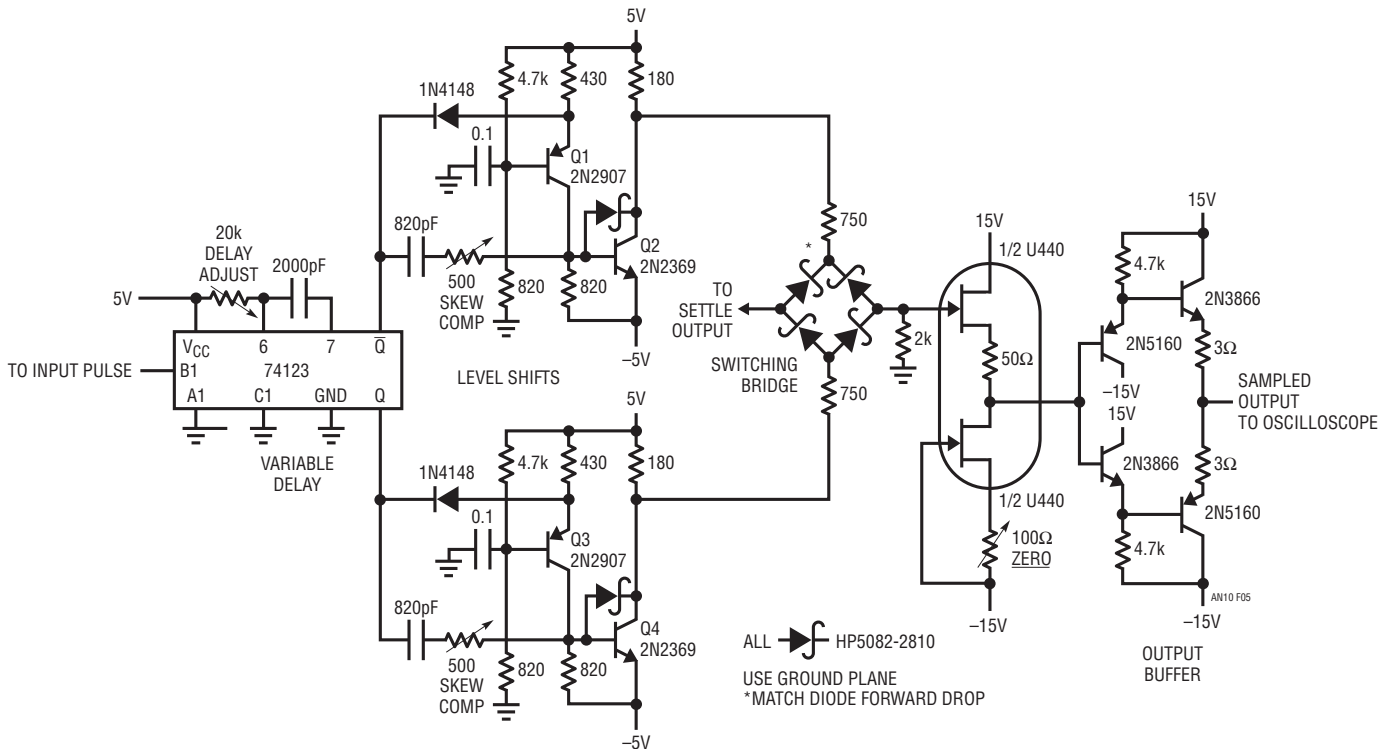

Figure 5. Sampling Switch for Ultra Precision Settling Time Measurement

bridge switching, yields a clean, switched output. An output buffer stage, identical to the one used in Figure 2, unloads the bridge and drives the oscilloscope.

The complementary bridge switching drive is supplied from the Q1-Q2 and Q3-Q4 level shifters. Each circuit converts the delay one-shot's TTL output to $\pm 5V$ levels. The identical stages are comprised of an emitter-switched current source feeding a Baker-clamped common emitter output. Feedforward capacitance to the output transistor aids speed and overall delays are about 3ns. The level shifters must switch simultaneously to minimize drive-induced disturbances in the bridge's output. The "skew compensation" trims permit very small phasing adjustments in each level shifter, compensating skew in the 74123 one-shot's outputs. To trim this circuit, ground the bridge input and pulse the 74123's C1 input. Next, set the oscilloscope to $100\mu V/\text{division}$ and adjust the skew trims for minimum indication on the screen. Connect the bridge input back to the settle circuit's output and the circuit is ready for use.

Construction of this circuit requires care. A ground plane is mandatory and all bridge connections should be as

short and symmetrical as possible. To maintain low noise, the bridge's output ground return should be routed away from high current returns such as the 74123's ground pin.

This switch circuit, carefully constructed and used with the basic settle circuit, provides good results. Figure 6 shows an LT1001 precision op amp as the AUT. Trace A is the input pulse, while Trace B is the AUT output. During the AUT's slewing period the 74123 is fired (Trace C is Q), turning off the bridge. The bridge input appears in Trace D. The 74123 delay is adjusted so the bridge is switched when settling is nearly complete. Trace E is the circuit's final output, showing settling details at $100\mu V/\text{division}$. The narrow peaking at the waveform's leading edge is due to switching residue. Figure 7 lists measured settling times to $50\mu V$ (0.0005% of a 10V step) for a group of precision amplifiers.

Some poorly designed amplifiers exhibit a substantial "thermal tail" after responding to an input step. This phenomenon, due to die heating, can cause the output to wander outside desired limits long after settling has apparently occurred. After checking settling at high speed it is

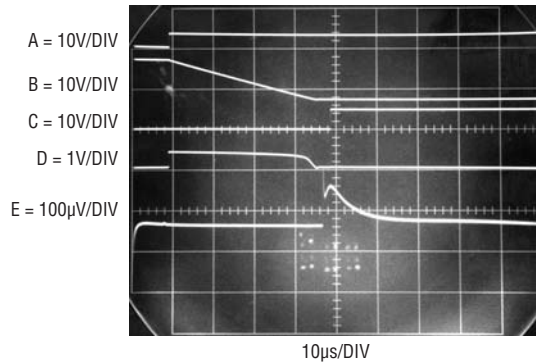

Figure 6. Sampling Switch Waveforms

Amplifier	Settling Time	Remarks
LT1001	65µs	
LT1007	18µs	
LT1008	65µs	Standard Compensation
LT1008	35µs	Feedforward Compensation
LT1012	70µs	
LT1055	6µs	
LT1056	5µs	

Figure 7. Measured Settling Times to 0.0005%

Application Note 10

always a good idea to slow the oscilloscope sweep down and look for thermal tails. Often the thermal tail's effect can be accentuated by loading the amplifier's output. Figure 8

shows the thermal tail of an amplifier, which appears to have settled in a much shorter time than it actually has.

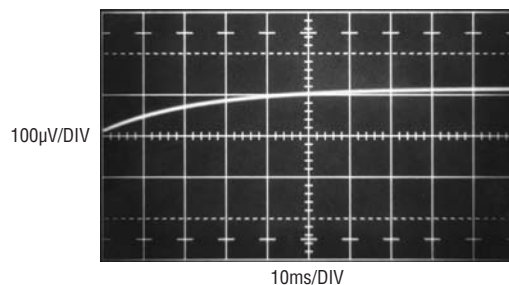

Figure 8. Typical Thermal Tail

REFERENCES

Analog Devices AD544 Data Sheet, "Settling Time Test Circuit."

National Semiconductor, LF355/356/357 Data Sheet, "Settling Time Test Circuit."

Precision Monolithics, Inc., OP-16 Data Sheet, "Settling Time Test Circuit."

R. Demrow, "Settling Time of Operational Amplifiers," *Analog Dialogue*, volume 4-1, 1970 (Analog Devices).

R. A. Pease, "The Subtleties of Settling Time," *The New Lightning Empiricist*, June 1971, Teledyne Philbrick.

W. Travis, "Settling Time Measurement Using Delayed Switch," Private Communication.

BOX SECTION A

Evaluating Oscilloscope Overload Performance

Settling time measurement relies heavily on the oscilloscope used. In many cases the oscilloscope is required to supply an accurate waveform after the display has been driven off screen. How long must one wait after an overload before the display can be taken seriously? The answer to this question is quite complex. Factors involved include the degree of overload, its duty cycle, its magnitude in time and amplitude and other considerations. Oscilloscope response to overload varies widely between types and markedly different behavior can be observed in any individual instrument. For example, the recovery time for a 100X overload at 0.005V/division may be very different than at 0.1V/division. The recovery characteristic may also vary with waveform shape, DC content and repetition rate. With so many variables, it is

clear that measurements involving oscilloscope overload must be approached with caution. Nevertheless, a simple test can indicate when the oscilloscope is being deleteriously affected by overdrive.

The waveform to be expanded is placed on the screen at a vertical sensitivity, which eliminates all off-screen activity. Figure A1 shows the display. The lower right hand portion is to be expanded. Increasing the vertical sensitivity by a factor of two (Figure A2) drives the waveform off-screen, but the remaining display appears reasonable. Amplitude has doubled and waveshape is consistent with the original display. Looking carefully, it is possible to see small amplitude information presented as a dip in the waveform at about the third vertical division. Some small disturbances

are also visible. This observed expansion of the original waveform is believable. In Figure A3, gain has been further increased, and all the features of Figure A2 are amplified accordingly. The basic waveshape appears clearer and the dip and small disturbances are also easier to see. No new waveform characteristics are observed. Figure A4 brings some unpleasant surprises. This increase in gain causes definite distortion. The initial negative-going peak, although larger, has a different shape. Its bottom appears less broad than in Figure A3. Additionally, the peak's positive recovery is shaped slightly differently. A new rippling disturbance is visible in the center of the screen. This

kind of change indicates that the oscilloscope is having trouble. A further test can confirm that this waveform is being influenced by overloading. In Figure A5 the gain remains the same but the vertical position knob has been used to reposition the display at the screen's bottom. This shifts the oscilloscope's DC operating point, which, under normal circumstances, should not affect the displayed waveform. Instead, a marked shift in waveform amplitude and outline occurs. Repositioning the waveform to the screen's top produces a differently distorted waveform (Figure A6). It is obvious that for this particular waveform, accurate results cannot be obtained at this gain.

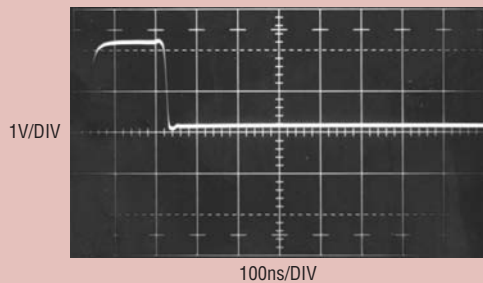

A1

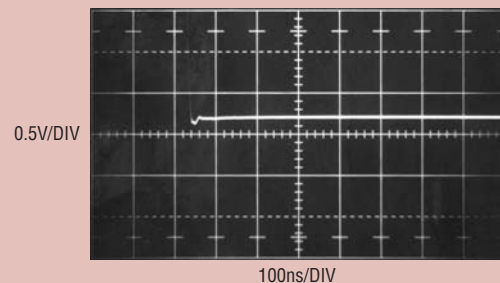

A2

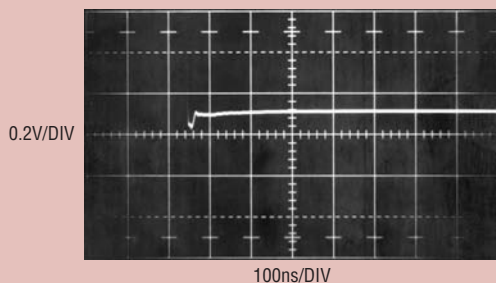

A3

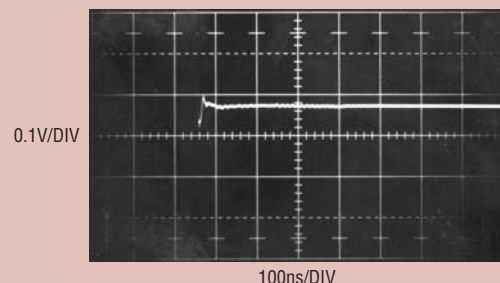

A4

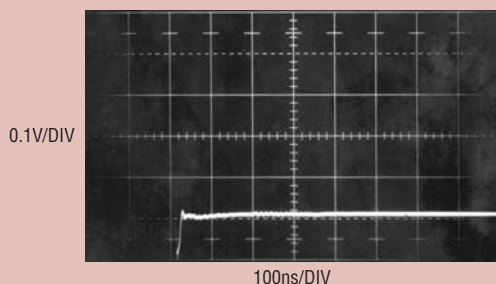

A5

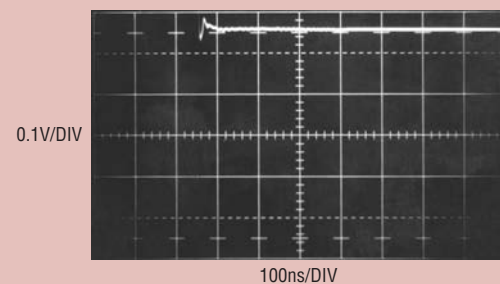

A6

Figures A1-A6. The Overdrive Limit is Determined by Progressively Increasing Oscilloscope Gain and Watching for Waveform Aberrations

BOX SECTION B

Amplifier Compensation

To get the best possible settling time from any amplifier, the feedback capacitor, C_F , should be carefully chosen. C_F 's purpose is to roll off amplifier gain at the frequency, which permits best dynamic response. The optimum value for C_F will depend on the feedback resistor's value and the characteristics of the source. One of the most common sources is also one of the most difficult. Digital-to-analog converters' current outputs must often be converted to a voltage. Although an op amp can easily do this, care is required to obtain good dynamic performance. A fast DAC can settle to 0.01% in 200ns but its output also includes a parasitic capacitance term, making the amplifier's job more difficult. Normally, the DAC's current output is unloaded directly into the amplifier's summing junction, placing the parasitic capacitance from ground to the amplifier's input. The capacitance introduces feedback phase shift at high frequencies, forcing the amplifier to "hunt" and ring about the final value before settling. Different DACs have different values of output capacitance. CMOS DACs have the highest output capacitance and it varies with code. Bipolar DACs typically have 20pF to 30pF of

capacitance, stable over all codes. Because of their output capacitance, DACs furnish an instructive example in amplifier compensation. In practice, the Schottky bridge which feeds the AUT in the settle circuit is replaced with the DAC to be used. Depending on DAC input coding, it may be necessary to use inverters in the DAC input lines to maintain circuit nulling action. Figure B1 shows the response of an industry standard DAC-80 type and an LT1023 op amp, which is optimized for inverting applications. Trace A is the input, while Traces B and C are the amplifier and settle outputs, respectively. In this example no compensation capacitor is used and the amplifier rings badly before settling. In B2, and 82pF unit stops the ringing and settling time goes down to 4 μ s. The overdamped response means that C_F dominates the capacitance at the AUT's input and stability is assured. If fastest response is desired, C_F must be reduced. B3 shows critically damped behavior obtained with a 22pF unit. The settling time of 2 μ s is the best obtainable for this DAC-amplifier combination.

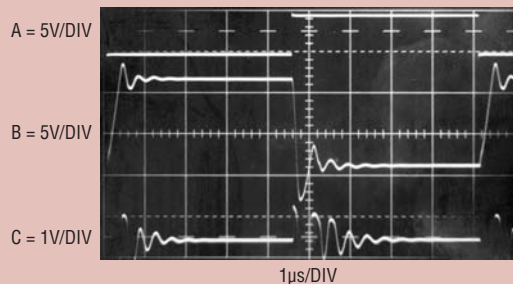

B1

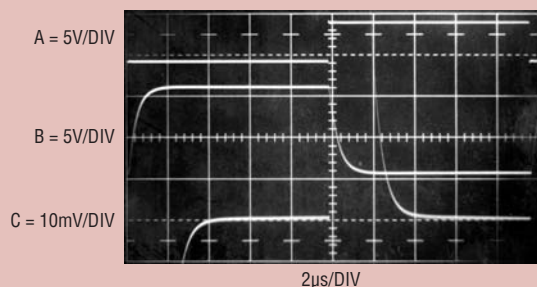

B2

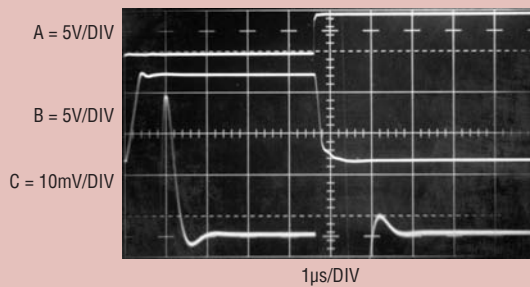

B3

Figures B1-B3. Effects of Different Feedback Capacitors on DAC-Op Amp Combination