

# DESIGN NOTES

## 2 AA Cells Replace 9V Battery, Extend Operating Life

Design Note 63

Steve Pietkiewicz

Operating life is an important feature in many portable battery-operated systems. In many cases the power source is the ubiquitous 9V “transistor” battery. 5V generation is accomplished with a linear regulator. Significant gains in battery life can be obtained by replacing the 9V/linear regulator combination with 2 AA cells and a step-up switching regulator. Two (alkaline) AA cells occupy 1.3 cubic inches, the same as a 9V battery, but contains 6WH of energy, compared to just 4WH in an alkaline 9V battery. Two AA cells also cost less than a 9V battery.<sup>1</sup> The additional energy in the AA cells provides longer operating life when compared to a 9V battery based solution.

An evaluation of the three approaches with a 30mA load illustrates the differences in battery life. An HP7100B strip chart recorder provides a nonvolatile record of circuit performance. The linear regulator circuit shown in Figure 1 uses an LT<sup>®</sup>1120 micropower low dropout regulator IC. A minimum of external components are required. No inductors or diodes are needed; however, the linear step-down process is inherently inefficient. The step-down switcher shown in Figure 2 uses an LT1173 configured in step-down mode driven from an alkaline 9V battery. In Figure 3 the step-up circuit uses an LT1173 configured in step-up mode driven from a pair of alkaline AA cells. The two switching circuits require an external inductor, diode and output capacitor in addition to the IC.

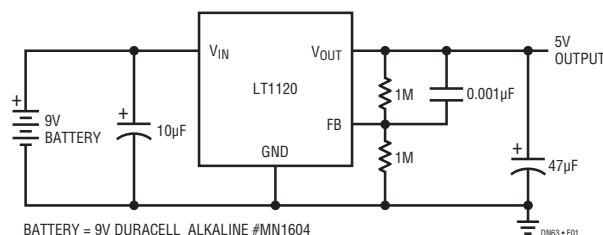

Figure 1. 9V to 5V Linear Regulator

1. A quick check at the local drugstore yielded \$2.99 for a 4-pack of alkaline AA cells and \$2.49 for a single 9V battery (after \$1.00 mail-in rebate).

Circuit operation of the switching step-down regulator is straightforward. A comparator inside the LT1173 senses output voltage on its “sense” pin. When  $V_{OUT}$  drops below 5V, the on-chip switch cycles. As current ramps up and ramps down in L1, it flows into C1 and the load, raising output voltage. When  $V_{OUT}$  rises above 5V, the cycling action stops and the regulator goes into a standby mode, pulling 110µA from the supply. C1 is left to supply energy to the load. These “bursts” of cycles occur as needed to keep the output voltage at 5V. 50mV of hysteresis at the sense pin eliminates the need for frequency compensation. The step-up regulator operates in a similar fashion, although in this case the inductor current flows into the load only on the discharge half of

LT, LT, LTC, LTM, Linear Technology and the Linear logo are registered trademarks of Linear Technology Corporation. All other trademarks are the property of their respective owners.

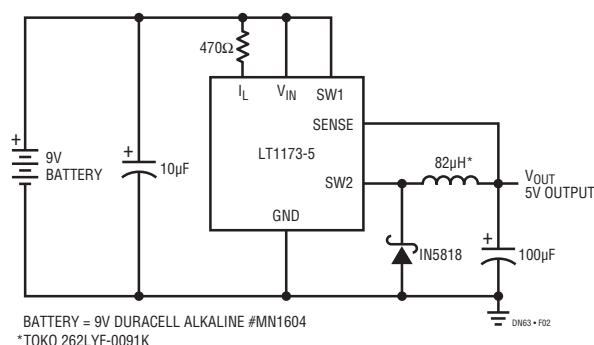

Figure 2. 9V to 5V Step-Down Regulator

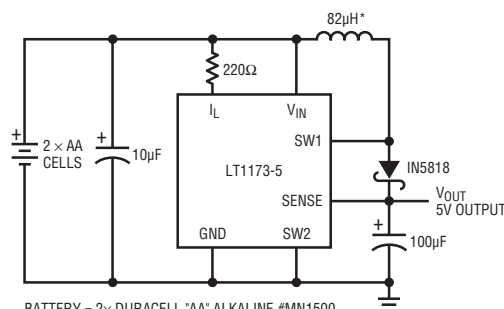

Figure 3. 3V to 5V Step-Up Regulator

the switch cycle. Output voltage is regulated in a similar manner.

Efficiency curves for the three circuits are shown in Figures 4 and 5. The linear regulator circuit has efficiency of 52% with a fresh battery. As the input-output differential decreases, the efficiency increases and at end of battery life exceeds 90%. Regulator ground current limits efficiency at drop-out. The switch-mode step-down circuit has almost constant efficiency, ranging from 84% at 6.3V input to 82% at 9.5V input. Minimum  $V_{IN}$  is set by the drop of the emitter follower switch inside the LT1173. Performance for the step-up converter is shown in Figure 5. At higher inputs, the switch drop is a lower percentage of supply, resulting in higher efficiency.

The three regulators show substantial differences in operating life. The linear regulator operates for 16.5 hours, as shown in Figure 6. Figure 7 shows a 19 hour operating life for the step-down switching circuit. The step-up

regulator circuit's performance, detailed in Figure 8, yields an operating life of 26 hours. This is an increase of 58% over the linear step-down approach at less cost and 37% over the switching step-down approach.

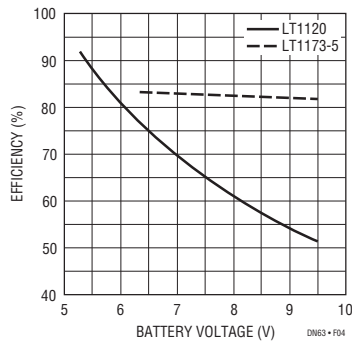

**Figure 4. Step-Down Conversion Efficiency – 5V Output, 30mA Load**

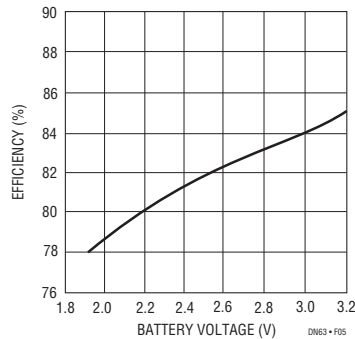

**Figure 5. Step-Up Conversion Efficiency – 5V Output, 30mA Load**

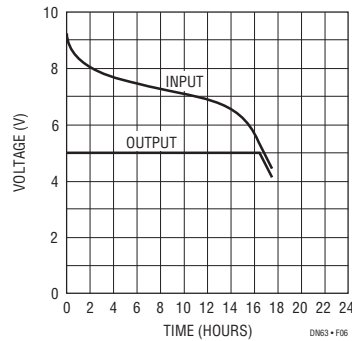

**Figure 6. 9V to 5V Step-Down Linear – LT1120, 30mA Load**

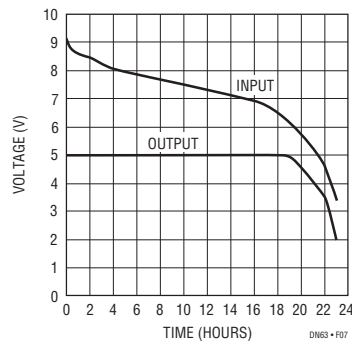

**Figure 7. 9V to 5V Step-Down Switcher – LT1173-5, 30mA Load**

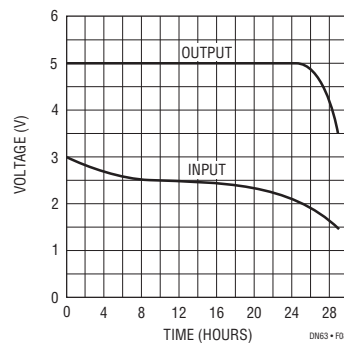

**Figure 8. 3V to 5V Step-Up Switcher – LT1173-5, 30mA Load**

Data Sheet Download

[www.linear.com](http://www.linear.com)

For applications help,  
call (408) 432-1900

**Linear Technology Corporation**  
1630 McCarthy Blvd., Milpitas, CA 95035-7417  
(408) 432-1900 • FAX: (408) 434-0507 • [www.linear.com](http://www.linear.com)

dn63f\_conv LT/GP 1092 190K • PRINTED IN THE USA

**LINEAR**  
TECHNOLOGY  
© LINEAR TECHNOLOGY CORPORATION 1992