

5V High Current Step-Down Switchers - Design Note 59

Ron Vinsant and Milton Wilcox

Low Cost High Efficiency (80%), High Power Density DC/DC Converter

The LT[®]1241 current mode PWM control IC can be used to make a simple high frequency step-down converter. This converter also has low manufacturing costs due to simple magnetic components. This circuit exhibits a wide input range of 30V to 60V while maintaining its 12A 5V output. It has short-circuit protection and uses minimal PC board area due to its 300kHz switching frequency.

Figure 1 shows the LT1241 being used to drive the switching transistor Q1 through a ferrite pulse transformer T2. This transformer is built on a high μ material resulting in an 11 turn bifilar wound toroid that is only 0.15 inches in diameter and can be surface mounted. T1 acts as a current sense transformer whose

volt • second balance is assured by the duty cycle limit of 50% inherent in the LT1241. The output inductor (L1) is made of Magnetics Kool-Mu material and is only 0.7 inches in diameter.

Short-circuit protection is provided through bootstrap operation of the LT1241. If the output is shorted the LT1241 limits its pulse width to ≤ 250 ns. Because there is not enough current supplied to make the aux winding on the output inductor 15V, the LT1241 stops operation. It will then try to start by C11 charging through R4. If the output is still shorted it will stop again. Thus in a short, the circuit starts and stops, protecting itself from overload.

LT, LT, LTC, LTM, Linear Technology and the Linear logo are registered trademarks of Linear Technology Corporation. All other trademarks are the property of their respective owners.

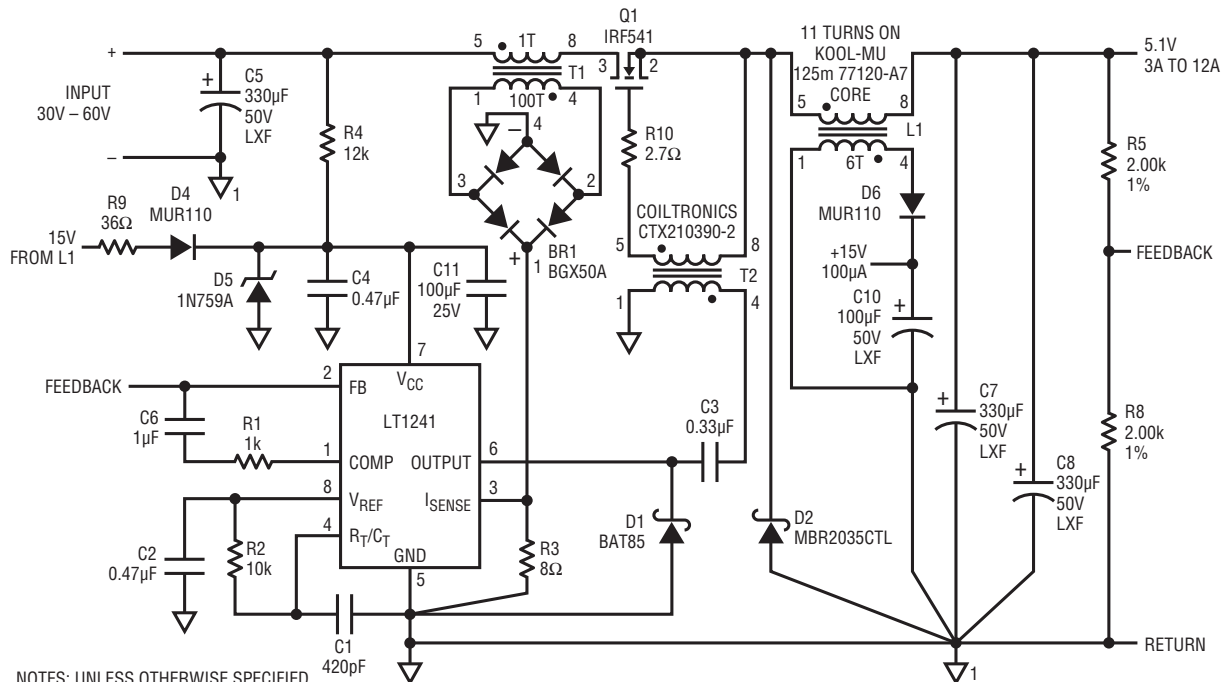

- NOTES: UNLESS OTHERWISE SPECIFIED
1. ALL RESISTANCES ARE IN OHMS, 1/4W, 5%.
 2. ALL CAPACITANCES ARE IN MICRO-FARADS, 50V, 10%.
 3. MBR2035CTL MOUNTING TAB IS TIED TO THE DEVICE'S CATHODES INTERNALLY.
 4. T1 METGLAS MP1305P-4AF CORE.

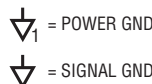

Figure 1

Synchronous Switching Eliminates Heat Sinks in a 50W DC/DC Converter

The new LT1158 half-bridge N-channel power MOSFET driver makes an ideal synchronous switch driver to improve the efficiency of step-down (buck) switching regulators. The diode losses in a conventional step-down regulator become increasingly significant as V_{IN} is increased. By replacing the high current Schottky diode with a synchronously-switched power MOSFET, efficiencies well over 90% can be realized (see Figure 2).

In the Figure 3 circuit an LT3525 provides a voltage mode PWM to drive the LT1158 input pin. The LT1158 drives

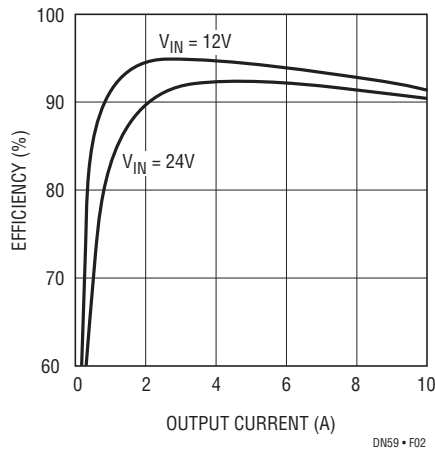

Figure 2. Operating Efficiency for Figure 3 Circuit

(2) 28mΩ power MOSFETs for each switch, reducing individual device dissipation to 0.7W worst case. This eliminates the need for heat sinks for operation up to 10A at a temperature of 50°C ambient. The inductor and current shunt losses for the Figure 3 circuit are 1.2W and 0.7W respectively at 10A.

An additional loss potentially larger than those already mentioned results from the gate charge being delivered to multiple large MOSFETs at the switching frequency. This driver loss can only be controlled by running the oscillator at as low a frequency as practical—in the case of the Figure 3 circuit, 25kHz. A very low ESR (<20mΩ) output capacitor is used to limit output ripple to less than 50mVp-p with 2.5Ap-p ripple current.

The LT1158 also provides current limit for DC/DC converter applications. When the voltage across R_S exceeds 110mV, the LT1158 fault pin conducts, and assumes control of the PWM duty cycle. This provides true current mode short-circuit protection with soft recovery. The Figure 3 regulator current limit is set at 15A which raises the dissipation in each bottom MOSFET to 1.7W during a short. Therefore 30°C/W heat sinking must be added for the bottom side MOSFETs if continuous short-circuit operation is required. Care should also be taken when routing the sense+ and sense- leads to prevent coupling from the inductor.

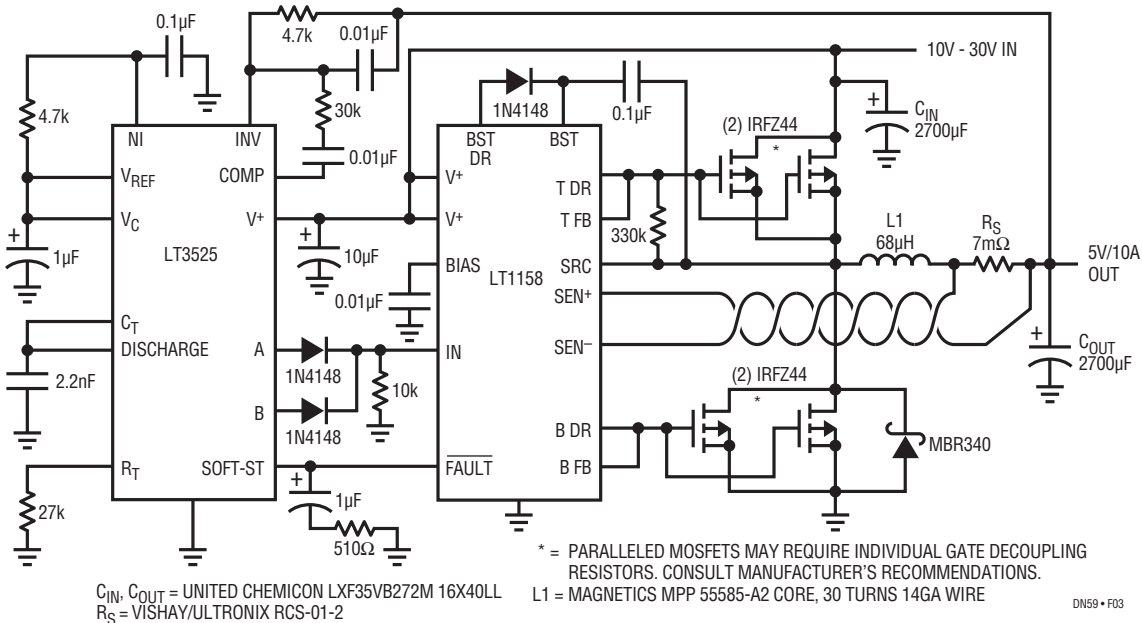

Figure 3. High Efficiency 50W DC/DC Converter

Data Sheet Download

www.linear.com

For applications help,
call (408) 432-1900

Linear Technology Corporation
 1630 McCarthy Blvd., Milpitas, CA 95035-7417
 (408) 432-1900 • FAX: (408) 434-0507 • www.linear.com

dn59f_conv BA/GP 0492 190K • PRINTED IN THE USA

LINEAR
 TECHNOLOGY
 © LINEAR TECHNOLOGY CORPORATION 1992