

LT1511 Constant-Voltage/ Constant-Current Lithium-Ion Battery Charger with Input Current Limiting

DESCRIPTION

Demonstration board DC103 is a complete Li-Ion battery charger designed for 1-, 2- or 3-cell applications. The LT[®]1511 is used in a high efficiency current mode step-down topology, capable of providing up to 3A of charging current. The 200kHz switching frequency allows small surface mount components to be used, thus minimizing board space and height. The precision voltage required by Li-Ion batteries is programmed by a resistor divider and the maximum battery charge current is programmed with a single 1/10W resistor (or a programming current from a DAC).

A unique feature of the LT1511 is its ability to monitor the input current from the power source, provide current to a load and to adjust the battery charging current accordingly, so as not to exceed a predetermined current from the input power source. This allows the input power supply or AC adaptor to provide current to power system circuitry and simultaneously charge a battery, without overloading the input power supply. As the system current require-

ments increase, the LT1511 begins adjusting the battery charging current downward to keep the input power supply current below a predetermined limit.

Jumpers JP1 and JP2, located on the demo board, are used to select the correct charging voltage for the number of cells being charged (4.2V, 8.4V or 12.6V). Battery charging current is programmed for 3A by resistor R11 and the current sense resistors R6, R9 and R15. Maximum input current (or AC adaptor current) is set for 3A by current sense resistor R4.

Also included on this demo board are a soft start function, undervoltage lockout (with an undervoltage lockout signal out) and provisions for driving the supply boost capacitor from an external low DC voltage, rather than from the battery voltage, to increase efficiency and thus reduce heat dissipation.

 LTC and LT are registered trademarks of Linear Technology Corporation.

BOARD PHOTO AND SIMPLIFIED BLOCK DIAGRAM

Component Side

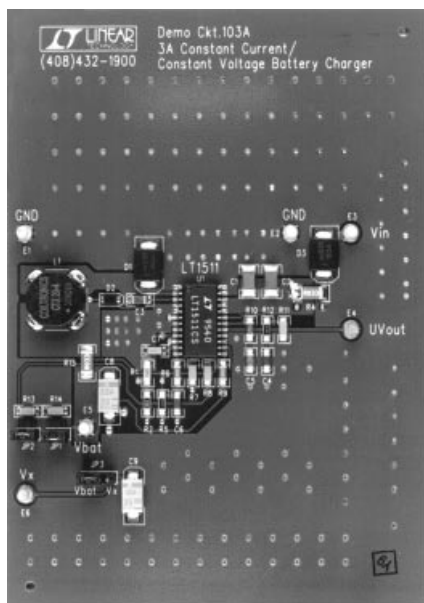

Simplified Block Diagram of Charger Application

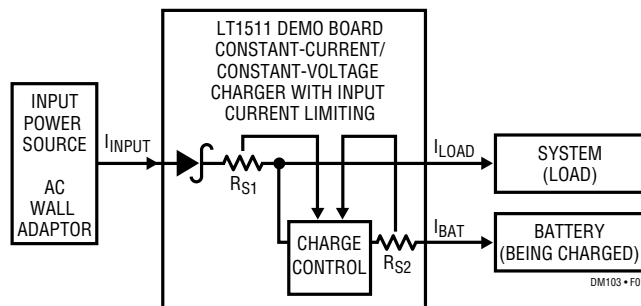

DEMO MANUAL DC103

BATTERY CHARGER

PERFORMANCE SUMMARY

PARAMETER	CONDITIONS	LIMITS
V_{IN}		$V_{OUT} + 3V \leq V_{IN} \leq 28V^*$
Battery Voltage (V_{BAT}) When Charging Terminates	$V_{IN} = 12V$ $V_{IN} = 16V$ $V_{IN} = 28V$	$4.2V \pm 0.85\%$ $8.4V \pm 0.85\%$ $12.6V \pm 0.85\%$
Maximum Battery Charging Current		$3A \pm 5\%$

*For $V_{IN} > 25V$, C1 and C2 should be replaced with a higher voltage rating.

PACKAGE AND SCHEMATIC DIAGRAMS

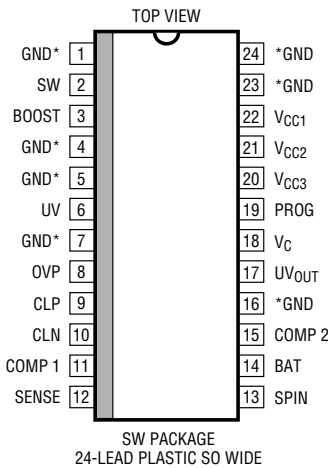

LT1511CSW
ALL GND PINS ARE FUSED TO INTERNAL DIE ATTACH PADDLE FOR HEAT SINKING TO PC BOARD
USE GENEROUS AMOUNTS OF PC BOARD COPPER AROUND LEADS (SEE LT1511 DATA SHEET AND DESIGN NOTE 124)

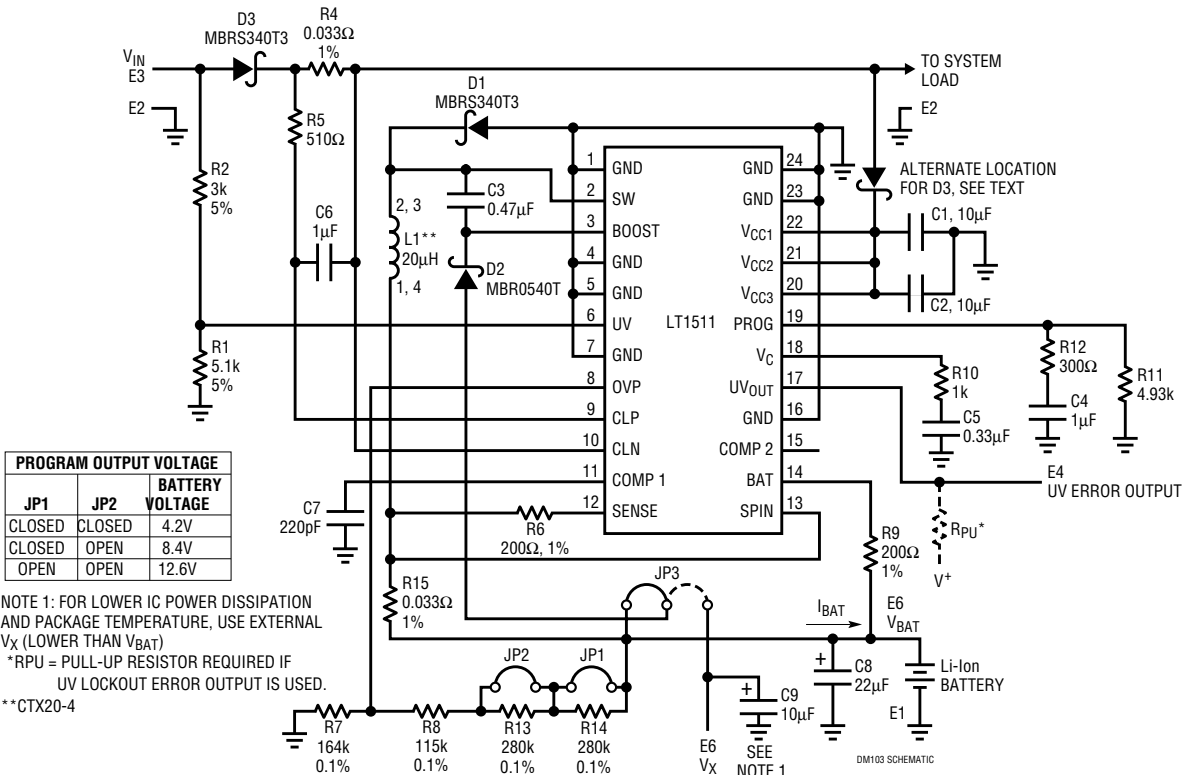

Figure 1. Demo Board Schematic

PARTS LIST

REFERENCE DESIGNATOR	QUANTITY	PART NUMBER	DESCRIPTION	VENDOR	TELEPHONE
C1, C2	2	1E106ZY5U-C304F-T THCS50EIE106Z	10 μ F 25V 20% Y5U Ceramic Capacitor	Tokin United Chemicon/Marcon	(408) 432-8020 (847) 696-2000
C3	1	12063G474ZAT2	0.47 μ F 25V Y5V Ceramic Capacitor	AVX	(803) 946-0362
C4, C6	2	12063G105ZATMA	1 μ F 25V Y5V Ceramic Capacitor	AVX	(803) 946-0362
C5	1	12063G334ZAT2	0.33 μ F 25V Y5V Ceramic Capacitor	AVX	(803) 946-0362
C7	1	12065A221KAT2A	220pF 50V NPO Ceramic Capacitor	AVX	(803) 946-0362
C8	1	TPSD226K025R0200	22 μ F 25V Tantalum Capacitor	AVX	(803) 946-0690
C9	1	TPSD106K035R	10 μ F 35V Tantalum Capacitor	AVX	(803) 946-0690
D1, D3	2	MBRS340LT3	3A 40V Schottky Diode	Motorola	(602) 244-3576
D2	1	MBR0540T	0.5A 40V Schottky Diode	Motorola	(602) 244-3576
E1 to E6	6	1502-2	Turret Test Point	Keystone	(718) 956-8900
JP1, JP2	2	TSW-102-07-G-S	2-Pin Jumper	Samtech	(800) 726-8329
JP3	4	TSW-103-07-G-S	2-Pin Jumper	Samtech	(800) 726-8329
L1	1	CTX20-4	20 μ H SMT Inductor	Coiltronics	(407) 241-7876
R1	1	CR32-5101F-T	5.1k 1/8W 5% Chip Resistor	IRC	(512) 992-7900
R2	1	CR32-302J-T	3k 1/8W 5% Chip Resistor	AVX	(803) 946-0524
R4, R15	2	LR2010-01-R033F	0.033 Ω 1/2W 1% Chip Resistor	IRC	(512) 992-7900
R5	1	CR32-511JT	510 Ω 1/8W 5% Chip Resistor	AVX	(803) 946-0524
R6, R9	2	CR32-2000F-T	200 Ω 1/10W 1% Chip Resistor	AVX	(803) 946-0524
R7	1	PFC-W1206R-03-1643-B	164k 1/10W 0.1% Chip Resistor	IRC	(512) 992-7900
R8	1	PFC-W1206R-03-1153-B	115k 1/10W 0.1% Chip Resistor	IRC	(512) 992-7900
R10	1	CR32-102J-T	1k 1/8W 5% Chip Resistor	AVX	(803) 946-0524
R11	1	PFC-W1206R-03-4931-B	4.93k 1/10W 0.1% Chip Resistor	IRC	(512) 992-7900
R12	1	CR32-3010F-T	300 Ω 1/10W 1% Chip Resistor	AVX	(803) 946-0524
R13, R14	2	PFC-W1206R-03-2803-B	280k 1/10W 0.1% Chip Resistor	IRC	(512) 992-7900
U1	1	LT1511CS	SO-24W Battery Charger IC	LTC	(408) 432-1900

OPERATION

The DC103 demonstration board is intended for evaluating the LT1511 switch-mode battery charger IC. This board contains all the components necessary for a 3A Li-Ion battery charger with input and charging current management control. It features soft start, undervoltage lockout, undervoltage error flag output and charging current shutdown.

The input current from the power source and the battery charging current are monitored using low value current sensing resistors located on the board. This information is then used by the LT1511 to control the battery charging current. Both the maximum input and the maximum

charging current levels are programmable. The maximum charging current is determined by the battery manufacturer and appropriate resistors are then selected to program this current. Likewise, the maximum current available from the input power source or AC adapter is determined by the manufacturer of the power source, and an appropriate resistor is then selected to program this current level.

By monitoring these currents, the input power source (or AC adapter) can simultaneously power a system load and charge a battery, without overloading the input power source.

OPERATION

The LT1511 can operate in a constant-voltage and/or constant-current mode. With a discharged battery connected, the charger will be in a constant-current mode. The maximum charge current is programmed by a resistor on the PROG pin. The battery will continue charging at the maximum rate until: 1) the battery voltage rises (as the battery approaches a charged condition) and the charger begins a constant-voltage charge, resulting in a decrease of charging current; or 2) the system load current increases, causing the input current to approach the limit set by the input current sense resistor, resulting in a decrease of charging current. If the system load current continues to rise, the charging current will continue to decrease, eventually reaching zero (see curve in Figure 3).

As shown in the Block Diagram on the first page, the current path is from the input power source through an antireversal diode and current sensing resistor (R_{S1}) to the output system load. There is an additional current path

through the charge control, through a second current sensing resistor (R_{S2}) to the battery being charged.

The LT1511 uses a NPN transistor as a power switch in a step-down topology. To achieve high efficiency, the circuit uses a supply boost capacitor to generate a voltage higher than the input voltage. This voltage is used to drive the base of the NPN switch, thus providing a low collector/emitter saturation voltage. With jumper JP3 in the V_{BAT} position (left), the voltage developed across the boost capacitor (C3) is identical to the battery voltage. The total base-drive voltage applied to the Boost pin is equal to the input voltage plus the voltage across the boost capacitor.

External Boost Voltage V_X

When charging higher voltage batteries (greater than 8V, for example) the boost diode D2 (V_X pin on the demo board) can be connected to a voltage lower than V_{BAT} , preferably a voltage between 3V and 6V. This will reduce power

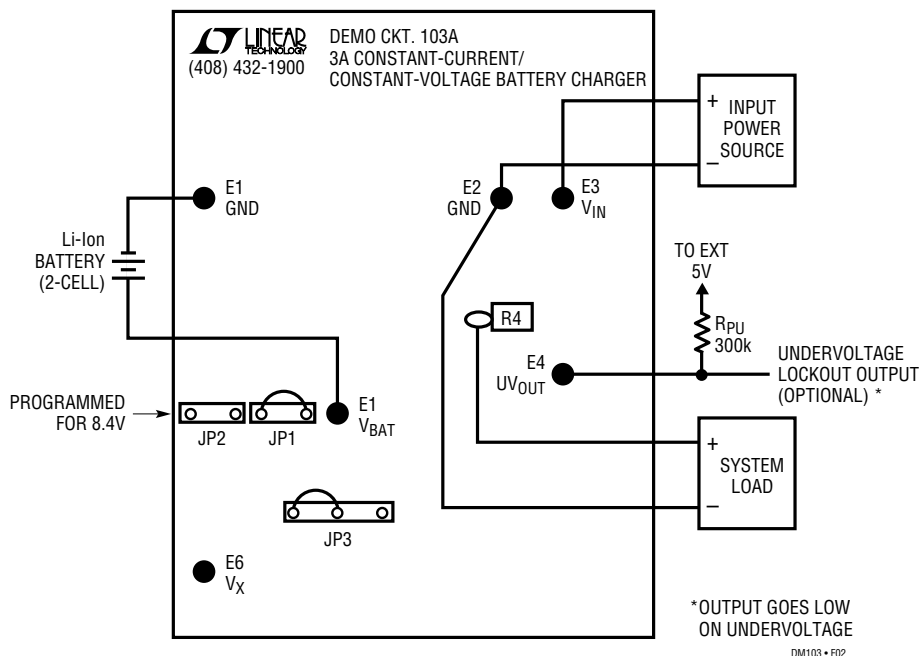

Figure 2. Typical Wiring Diagram of Demo Board

OPERATION

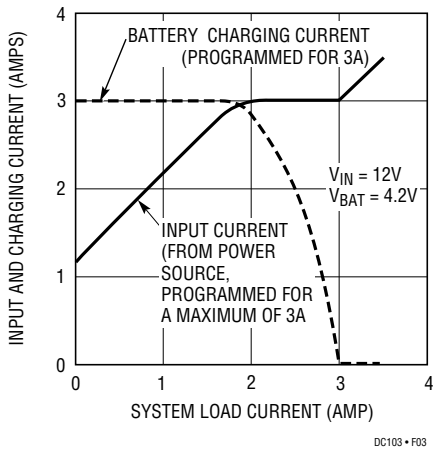

Figure 3. System Load Current vs Input and Charging Current

dissipation in the IC, thus lowering package temperature. It will also reduce the dropout voltage by increasing the maximum switch duty cycle from 90% to 93%. The current needed from this supply is less than 50mA. See LT1511 data sheet for additional information.

JP3, which contains three pins, selects whether the onboard charge pump consisting of D2 and C3 obtains its voltage from V_{BAT} or from an external voltage applied to the V_X terminal. The jumper JP3 is preset for V_{BAT} (left and center pins). To use an external voltage on V_X , place the jumper between the center pin and the right pin.

Powering Up The Demo Board

Demo board DC103 can accept input voltages up to 28V and includes a resistor divider to select among three output voltages for charging either 1, 2 or 3 cells. The maximum input current and the maximum battery charging current are both programmed for 3A.

Before applying power to the board, select the correct charging voltage for the number of cells being charged (4.2V, 8.4V or 12.6V). This is done by a combination of jumpers (JP1 and JP2) on the board. See Schematic Diagram for jumper information on programming output voltage.

Connect a power supply set for approximately 4V greater than the battery voltage (capable of at least 3A of output current) to the V_{IN} and GND terminals on the board. Solder terminals are provided for easy hookup. For evaluation purposes, a means of measuring currents is recom-

mended. Connect a discharged lithium-ion battery between the V_{BAT} and GND terminals. Locate the small loop terminal directly to the left of current sensing resistor R4 and connect the positive side of a system load, such as a laptop computer or some other type of electronic equipment (or an adjustable load resistor), to it. The negative side of the load is returned to the GND terminal, but do not connect this yet. See Figure 2 for the wiring diagram. Maximum battery charging current is programmed for 3A by resistor R11 and the current sense resistors R6, R9 and R15. Maximum input current (or AC adapter current) is set for 3A by current sense resistor R4.

Apply input power to the board. With a discharged battery connected to the board and no system load, the battery will begin charging at 3A. Connect an adjustable system load and begin increasing the load current. As the system load increases, the input current also increases. When the input current reaches the programmed limit, the maximum charging current will begin to decrease (see curve shown in Figure 3). For example, with a 1A system load, the available charging current is the full 3A, and the input current is 2.25A. If the system load increases to 2.5A, the charging current drops to 2A, because the input current has reached the programmed limit of 3A.

As the battery charges, the battery voltage rises and approaches the programmed voltage of either 4.2V, 8.4V or 12.6V. The charger will then maintain a constant voltage across the battery, with the charging current decreasing to zero over time as the battery reaches a fully charged condition.

Some Li-Ion battery manufacturers recommend terminating the constant-voltage float mode after the charge current has dropped below a specific level (typically 50mA to 100mA) and a specific amount of time has elapsed (typically from 30 to 90 minutes). This may extend the life of the battery, but check with the manufacturer of the battery you are using for details. See the LT1511 data sheet for additional applications information.

Undervoltage Lockout

Undervoltage lockout keeps the charger off until the input voltage reaches a minimum threshold level. The threshold voltage on the Undervoltage Lockout pin (Pin 6) is ap-

OPERATION

proximately 6.7V when the input is rising, and contains a hysteresis of 0.5V. This voltage can be adjusted upward by adding a resistive divider (as shown on the demo board schematic). With the resistors shown, the undervoltage lockout voltage with the input rising is approximately 10.6V. The following formula is used to determine undervoltage lockout threshold level.

$$\text{Undervoltage Lockout} = 6.7V \left(1 + \frac{R2}{R1} \right)$$

This undervoltage lockout feature is useful in situations where the input power source is current limited and cannot deliver full power upon start-up or at reduced input voltages. The undervoltage lockout prevents the input power source from going into an overload condition on startup. One additional note: this UV feature affects only the charging current (I_{BAT}) and does not interrupt the current flow to the system load.

An undervoltage lockout error output, consisting of an open NPN collector, can be used to provide an indication of insufficient input voltage. An external pull-up resistor to a positive voltage (such as the system 5V) is needed at this pin (terminal E4 on the demo board). The pull-up resistor value must be large because of the limited current sinking capability (100 μ A) of this transistor. This output remains low for an undervoltage lockout status and goes high when the UV threshold is exceeded. With a battery connected, the undervoltage lockout output remains low, even with the input power removed.

Soft Start and Shutdown

The V_C pin (Pin 18) on the LT1511 can be used for soft start or I_{BAT} shutdown. The soft start feature ensures that the charging current will rise in an orderly and controlled fashion. A capacitor on this pin is charged from an internal 45 μ A current source, creating a ramp voltage that controls the I_{BAT} rise time. A 0.33 μ F capacitor will provide a rise time of approximately 10ms.

The V_C pin can also be used to shut down the charger. Pulling this pin low stops the charging current but does not put the IC into the sleep mode.

Reverse Battery Drain Current

The IC goes into a sleep mode when the input voltage is removed. In the sleep mode, the drain from the battery due to the LT1511 is approximately 3 μ A. If the battery will remain connected to the charger for an extended period of time, all battery-draining current paths should be identified. With the values shown, the voltage divider resistors account for 15 μ A of battery drain current. To eliminate this current, a MOSFET disconnect for the divider can be added, as shown in the LT1511 data sheet.

If the input voltage is removed and the system load remains connected, the system will remain powered by the battery through an internal parasitic diode from the switch pin to the V_{CC} pin. Relocating diode D3 as shown in Figure 1 will disconnect the load from the battery. See the latest LT1511 data sheet for additional information.

Another source of battery drain is the leakage current of Schottky diodes D1 and D3. Leakage currents can be greater than 100 μ A at room temperature and can go much higher at higher temperatures. Selecting a low leakage Schottky diode, such as a Motorola MBRD340, can lower that number considerably. Also, the antireversal diode D3 can be replaced with a low leakage silicon diode if the higher diode forward voltage and slightly increased power dissipation can be tolerated.

Selecting Charging Current Resistors

Both the maximum battery charging current and the maximum current from the power source are programmable.

The basic formula for charging current is (refer to schematic diagram):

$$I_{BAT} = I_{PROG} \left(\frac{R9}{R15} \right) = \left(\frac{2.465}{R11} \right) \left(\frac{R9}{R15} \right)$$

Select the current flowing out of the PROG pin (I_{PROG}) to be approximately 500 μ A. The voltage present at the PROG pin is 2.465V.

$$\text{For } I_{PROG} = 500\mu\text{A, make } R11 = \frac{2.465}{500\mu\text{A}} = 4.93\text{k}$$

OPERATION

To program 3A of charging current, select the current sensing resistor R15 to have approximately 100mV across it when 3A is flowing.

$$\text{Make } R15 = \frac{100\text{mV}}{3\text{A}} = 0.033\Omega$$

For biasing purposes, R6 should be equal to R9.

$$R9 = R6 = \frac{(I_{\text{CHARGE}})(R11)(R15)}{2.465\text{V}} = \frac{(3\text{A})(4.93\text{k})(0.033)}{2.465\text{V}} = 200\Omega$$

Keep in mind that when V_{IN} is present, there is about 200 μA of current flowing out of the BAT and Sense pins. If the battery is removed, this 200 μA will cause the terminal to rise above the programmed voltage and approach V_{IN} . If this is a problem, the current through the resistor voltage divider can be increased to approximately 500 μA to provide a minimum load at the V_{BAT} terminal. A MOSFET will then be needed to disconnect the resistor divider from the battery when V_{IN} is removed. See the LT1511 data sheet for information on disconnecting the voltage divider.

Selecting an Input Current Limit Resistor

The output current from the input power source is sensed by a low value resistor, R4. This sense voltage is fed into the CLN (current limit negative) and CLP (current limit positive) pins of the LT1511. When this voltage exceeds 100mV, the circuit will begin to override (decrease) the maximum charging current that is programmed. To program the maximum input current for 3A:

$$R4 = \frac{100\text{mV}}{3\text{A}} = 0.033\Omega$$

Thermal Considerations

When operating the charger near maximum power levels or at elevated ambient temperatures, some precautions with regard to maximum junction temperatures must be taken. The LT1511 is packaged in a specially constructed 24-pin surface mount plastic package. The package uses a total of seven ground pins, which are directly attached (fused) to the die-attach paddle for maximum heat transfer. The majority of the heat generated by the chip is conducted to the PC board through the copper leads of the IC, especially the ground leads.

The PC board is the heat sink for the LT1511 and the other heat-producing components on the board. Many items contribute to the effectiveness of the PC board as an efficient heat sink. Most important is the amount of PC board copper around the leads (especially the ground leads). Use as much as is practical. Total board size, number of layers, copper area, copper thickness, board thickness, quantity and type of components on the board, board orientation, still or moving air and even board temperature are all factors in how effective a heat sink the PC board is. See Design Note 124 for additional information on the thermal characteristics of the LT1511.

Calculations of maximum IC junction temperature using IC thermal resistance and IC power dissipation numbers can often result in erroneous junction temperatures. This is because of the many PC board variables mentioned above, and because there are other heat producing components on the board, such as two diodes, two current sensing resistors and an inductor. To ensure that maximum IC junction temperatures are within the device ratings of 125°C, it is recommended that a temperature measurement be taken. The suggested method is to solder a small (26 to 30 gauge) thermocouple to the top of one of the IC ground leads, preferably a ground lead near the center of the package (because it is closer to the die). At maximum output power, the peak junction temperature is approximately 10°C hotter than the ground lead. Keep the maximum junction temperature below 125°C or, for a more conservative design, a 115°C temperature could be used.

DEMO MANUAL DC103 BATTERY CHARGER

PCB LAYOUT AND FILM

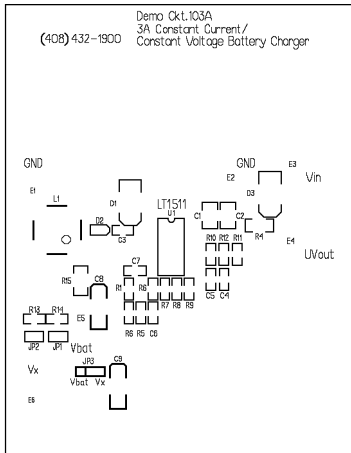

Component Side Silkscreen

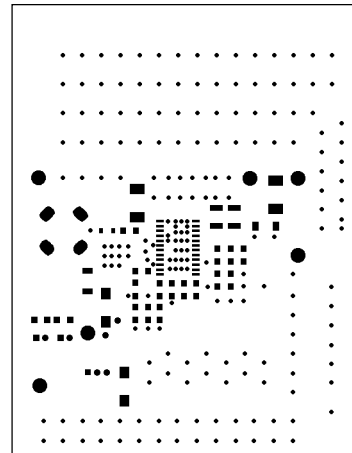

Component Side Solder Mask

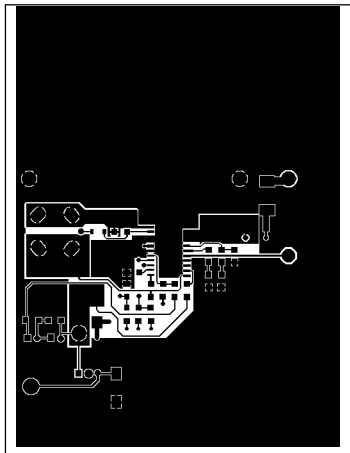

Component Side

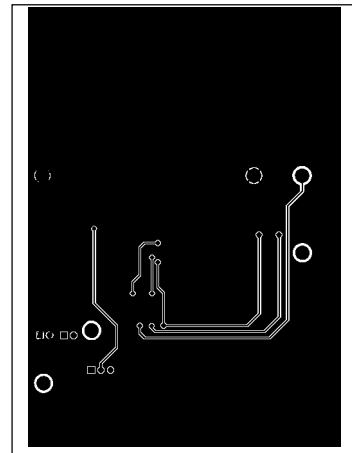

Solder Side

PC FAB DRAWING

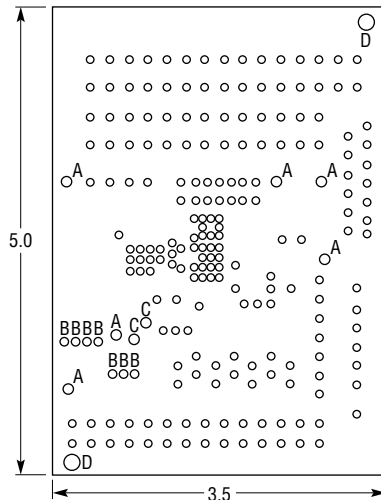

NOTES:

1. BOARD MATERIAL IS FR-4, 0.062" THICK, 2 OZ. COPPER
2. PCB WILL BE DOUBLE-SIDED WITH PLATED THROUGH HOLES
3. SOLDERMASK BOTH SIDES WITH PC401.
SILKSCREEN COMPONENT SIDE. USE WHITE NONCONDUCTIVE INK
4. ALL DIMENSIONS IN INCHES ± 0.005

SYMBOL	DIAMETER	NUMBER OF HOLES
UNMARKED	18	201
A	94	6
B	37	7
C	35	2
D	70	2
TOTAL HOLES		218

DM103 • PC FAB DWG