

DESIGN NOTES

60V, 3A Step-Down DC/DC Converter Has Low Dropout and 100µA Quiescent Current – Design Note 352

Keith Szolusha

Introduction

High voltage bipolar monolithic step-down converters are usually optimized for high efficiency at *high* output currents, often at the expense of light load efficiency and operation near dropout. The problem is that a 2mA quiescent current at zero load drains batteries in applications that spend long periods of time at minimum load current. One common solution for reducing quiescent current and improving battery run-time is a shutdown function, but shutdown drops the output voltage to zero. Shutdown is not acceptable in systems where a constant regulated output voltage is required for light load applications, system diagnostics and ready-to-use load transients. In some systems, a regulated output voltage is needed at very low input voltage (low dropout). Simply shutting down the converter to zero output to avoid output droop is not always an option.

The LT[®]3434, 3A monolithic buck switching regulator is designed to optimize efficiency over *all* current and voltage levels, both high and low. Micropower bias current and Burst Mode[®] operation enable it to consume merely 100µA at zero load and 12V input. The high efficiency bipolar NPN power switch (0.1Ω) provides up to 85% efficiency at a 2A load current. Combined with high duty cycle, the low dropout of the switch

maintains a regulated 3.3V output down to 4V input at all load currents. This is important for automotive cold-crank operation.

The LT3434's 3.3V to 60V input voltage range makes it ideal for 14V and 42V automotive battery-fed applications with both 4V cold crank and high input voltage transients (up to 60V). The 3A switch current rating provides maximum load currents of up to 2.5A. The LT3434 maintains output regulation down to 4V input for 3.3V output and down to 3.3V input for 2.5V or lower output voltages.

The high input voltage and low quiescent current make this an ideal choice for many 48V nonisolated telecom applications, 40V FireWire peripherals and multisource battery-powered applications with autoplug adaptors. The LT3434 can survive load-dump input transients up to 60V that are common in these systems.

It also includes other important features to shrink solution size, simplify configuration and improve system robustness:

- Fixed 200kHz switching frequency provides low output ripple, high efficiency and the ability to provide

LT, LT, LTC, LTM, Linear Technology, the Linear logo and Burst Mode are registered trademarks of Linear Technology Corporation. All other trademarks are the property of their respective owners.

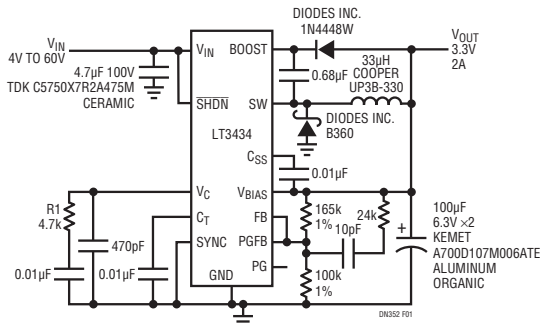

Figure 1. LT3434 Wide Input Voltage Range DC/DC Converter Application to 3.3V Output at 2A Load Current Featuring Burst Mode Operation for Light Load Operation and 4V Low Dropout Operation

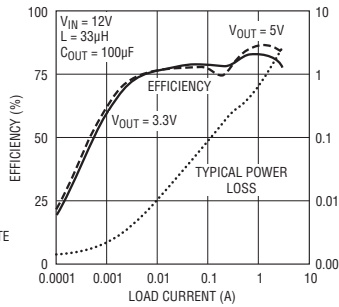

Figure 2. The Efficiency of Figure 1 is Typically Greater Than 75%. At Light Loads, Supply Current is Minimized with Burst Mode Operation

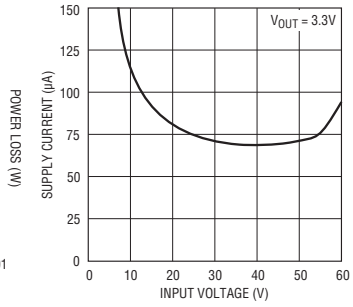

Figure 3. With Zero Load Current, the Supply Current to the LT3434 is Extremely Low, Typically Below 100µA (VIN ≥ 12V)

wide input voltage range solutions. The LT3434 can be synchronized at frequencies up to 700kHz.

- The shutdown pin provides a 2.38V undervoltage lockout threshold as well as a 0.4V threshold for micropower shutdown ($<1\mu\text{A}$).
- A single capacitor provides soft-start capabilities and limits inrush current and output voltage overshoot in sensitive applications.
- A power good flag and power good comparator provide the system with an indication that the output voltage, the input voltage or some other line is above a desired voltage.
- The LT3434 is provided in a small 16-pin TSSOP thermally enhanced package for excellent thermal performance.

Burst Mode Operation

Figure 1 shows a typical wide input voltage range step-down application to 3.3V output DC/DC converter. Burst Mode operation reduces light load quiescent current by disabling switching for a number of switch cycles and placing the part briefly in micropower shutdown until switching begins again. Bursts of switch pulses are enough to maintain output voltage regulation at light load. Figure 2 shows that the efficiency is high for nominal loads, between 100mA and 2A, and that at light load the quiescent current only sips from the battery during long periods of system inactivity. Figure 3 shows that for most typical input voltages, zero load quiescent current is below 100 μA .

Low Dropout

The LT3434 provides extremely low dropout with high maximum duty cycle (90%) and low power switch on-resistance (0.1 Ω). Figure 4 demonstrates how the LT3434 maintains 3.3V output regulation with an input voltage down to 4V over the entire load current range. The minimum input voltage required to start up the output is slightly higher, as shown in Figure 4. Starting up the LT3434 at a duty cycle lower than maximum helps get the boost voltage high enough to run the power switch in low $V_{\text{CE(SAT)}}$ operation before entering extremely low dropout.

Soft-Start

Only a single capacitor (C_{SS} in Figure 1) is required for soft-start. Soft-start avoids the problems created by large inrush currents at start-up, where switchers

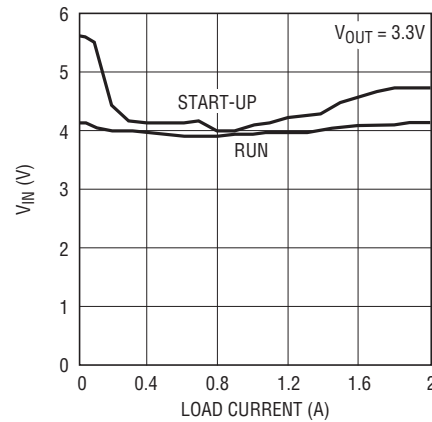

DN352 F04

Figure 4. Low Dropout Operation for 3.3V Output is as Low as 4V Over the Entire Load Current Range. Start-Up Requires Slightly Higher Input Voltage

without soft-start try to go from zero to regulation by consuming as much current as possible from the source and casting it into the output capacitor and load. This surge of current can both drag down a battery source voltage and cause overshoot in the output voltage. The soft-start capacitor for the LT3434 holds the peak current level clamp low, allowing it to slowly rise upon start-up. An external soft-start capacitor removes the inrush current surge and limits output voltage overshoot by controlling the output voltage ramp-up rate.

Power Good

For systems that rely upon having a well regulated power source or that follow a particular power-up sequence, the LT3434 provides a power good flag with programmable delay. The delay is programmed by C_{T} , starting when the power good feedback pin exceeds 90% of V_{REF} (1.25V). By tying the power good feedback pin (PGFB) directly to the feedback pin (FB), the power good comparator returns a “good” signal only when the output voltage has reached 90% and the C_{T} voltage exceeds its internal clamp. The power good feedback pin can also be tied to the input voltage, an external source or a resistor divider on any of these sources.

Conclusion

The LT3434 is a wide input voltage range, 200kHz, monolithic 3A, step-down DC/DC converter. High input voltage, high power switch capabilities, low quiescent current, low dropout and excellent package thermal conductivity make this an extremely useful and versatile IC that is simple to use in many step-down applications.

Data Sheet Download

www.linear.com

For applications help,
call (408) 432-1900