

QUICK START GUIDE FOR DEMONSTRATION CIRCUIT 1069A

MONOLITHIC STEP-DOWN SWITCHING REGULATOR WITH LDO

LT3500

DESCRIPTION

Demo circuit 1069A is a monolithic step-down switching regulator with LDO featuring LT3500. The demo circuit is designed for 5.0V and 3.3V outputs from a 6V to 36V input. The LDO output is configured as a post-regulator of the switching regulator output. The total current capability is up to 2A.

The switching regulator can be synchronized to an external clock input or be resistor-programmed to a 250 kHz to 2.2MHz internal oscillator. Programmable frequency allows for optimization between efficiency and external component size. Cycle-by-cycle current limit, frequency foldback and thermal shutdown provide protections against a shorted output. The soft-start feature controls the ramp rate of the output voltage, eliminates

input current surge during startup, and also provides output tracking.

The LT3500's low current shutdown mode (<12uA) enables easy power management in battery-powered systems.

The LT3500 datasheet gives a complete description of the part, operation and application information. The datasheet must be read in conjunction with this quick start guide for demo circuit 1069A.

Design files for this circuit board are available. Call the LTC factory.

 , LTC and LT are registered trademarks of Linear Technology Corporation.

Performance Summary ($T_A = 25^\circ\text{C}$)

PARAMETER	CONDITION	VALUE
Minimum Input Voltage		6V
Maximum Input Voltage		36V
Output Voltage V_{OUT1}		5.0V $\pm 4\%$
Output Voltage V_{OUT2}		3.3V $\pm 4\%$
Switching Frequency		800kHz
Maximum Total Output Current ($I_{OUT1} + I_{OUT2}$)		2.0A
Voltage Ripple V_{OUT1}	$V_{IN}=12\text{V}, I_{OUT1}=1.5\text{A}$	10mV
Voltage Ripple V_{OUT2}	$V_{IN}=12\text{V}, I_{OUT2}=0.5\text{A}$	5mV

QUICK START GUIDE FOR DEMONSTRATION CIRCUIT 1069A

MONOLITHIC STEP-DOWN SWITCHING REGULATOR WITH LDO

QUICK START PROCEDURE

Demo circuit 1069A is easy to set up to evaluate the performance of the LT3500. Refer to Figure 1 for proper measurement equipment setup and follow the procedure below:

NOTE . When measuring the input or output voltage ripple, care must be taken to avoid a long ground lead on the oscilloscope probe. Measure the input or output voltage ripple by touching the probe tip directly across the V_{IN} or V_{OUT} and GND terminals. See Figure 2 for proper scope probe technique.

1. Place JP1 on the RUN position.
2. With power off, connect the input power supply to V_{IN} and GND.

3. Turn on the power at the input.

NOTE . Make sure that the input voltage does not exceed 36V.

4. Check for the proper output voltages.

NOTE . If there is no output, temporarily disconnect the load to make sure that the load is not set too high.

5. Once the proper output voltages are established, adjust the load within the operating range and observe the output voltage regulation, ripple voltage, efficiency and other parameters.

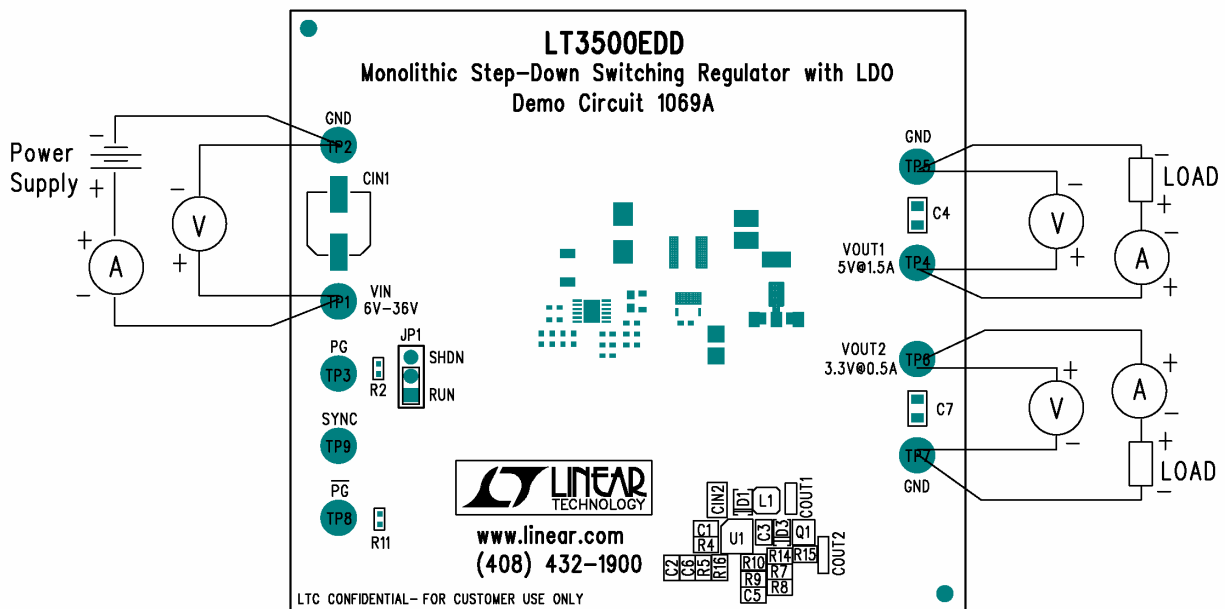

Figure 1. Proper Measurement Equipment Setup

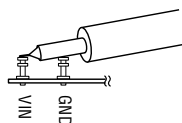
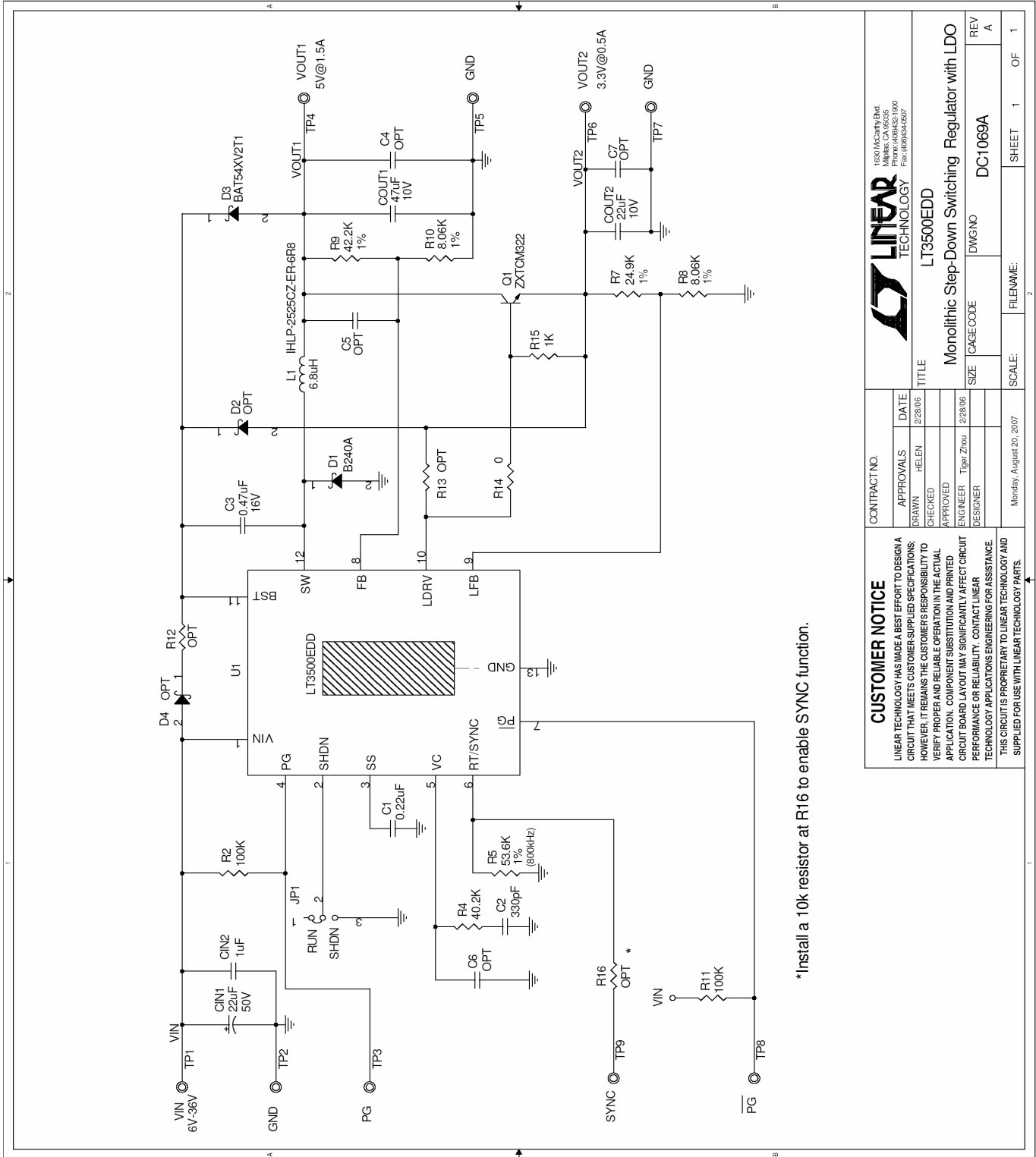

Figure 2. Measuring Input or Output Ripple

QUICK START GUIDE FOR DEMONSTRATION CIRCUIT 1069A

MONOLITHIC STEP-DOWN SWITCHING REGULATOR WITH LDO



CUSTOMER NOTICE		CONTRACT NO.	
LINEAR TECHNOLOGY HAS MADE A BEST EFFORT TO DESIGN A CIRCUIT THAT MEETS CUSTOMER-SUPPLIED SPECIFICATIONS; HOWEVER, IT REMAINS THE CUSTOMER'S RESPONSIBILITY TO VERIFY PROPER AND RELIABLE OPERATION IN THE ACTUAL APPLICATION. COMPONENT SUBSTITUTION AND PRINTED CIRCUIT BOARD LAYOUT MAY SIGNIFICANTLY AFFECT CIRCUIT PERFORMANCE OR RELIABILITY. CONTACT LINEAR TECHNOLOGY APPLICATIONS ENGINEERING FOR ASSISTANCE.		Monday, August 20, 2007	
THIS CIRCUIT IS PROPRIETARY TO LINEAR TECHNOLOGY AND SUPPLIED FOR USE WITH LINEAR TECHNOLOGY PARTS.		SCALE: FILENAME: SHEET 1 OF 1	
LINEAR TECHNOLOGY		TITLE: LT3500EDD	
1820 McCarthy Blvd. Milpitas, CA 95035 Phone: (408) 999-1900 Fax: (408) 999-6007		Monolithic Step-Down Switching Regulator with LDO	
REV A		DC1069A	
DWGNO		CAGE CODE	