

DESIGN NOTES

Highly Integrated High Efficiency DC/DC Conversion

Design Note 98

San-Hwa Chee and Howard Haensel

The LTC[®]1574 and LTC1265 high efficiency step-down regulators minimize external components by using integrated low $R_{DS(ON)}$ P-channel switches. The LTC1574 goes one step further by including a low forward drop Schottky diode—an industry first. Both regulators also include on-chip low-battery detectors.

Burst Mode[®] operation allows the LTC1574 and LTC1265 to achieve over 90% efficiency for load currents as low as 10mA. Current mode operation provides clean start-up, accurate current limit, and excellent line and load regulation. Inherent 100% duty cycle in dropout allows the user to extract maximum battery life. Both regulators can be shut down to a few microamperes.

LTC1574

The LTC1574 features the highest level of integration for a switching regulator. Besides an on-chip power MOSFET, it includes a low forward drop Schottky diode. The user needs only to provide an inductor and input/output filter capacitors for a complete high efficiency step-down converter. The current limit is pin selectable to either 340mA or 600mA, optimizing efficiency for a wide range of load currents.

Figure 1 shows a typical LTC1574 surface mount application requiring only three external components. It provides 3.3V at 150mA from an input voltage of 5V. Peak inductor current is limited to 340mA by connecting pin 6 (I_{PGM}) to ground. For applications requiring higher output current, connect pin 6 to V_{IN} . Under this condition the maximum load current is increased to

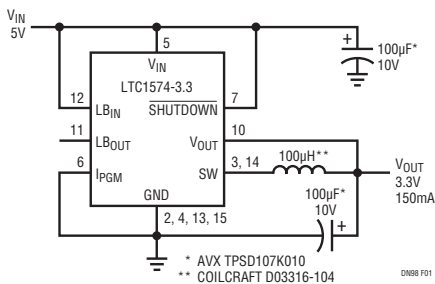

Figure 1. LTC1574 3.3V, 150mA Surface Mount

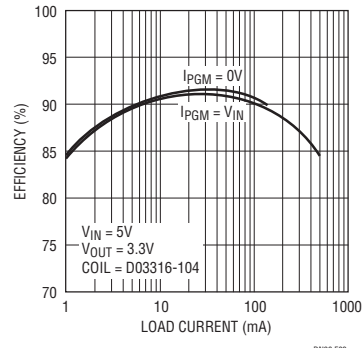

Figure 2. LTC1574 5V to 3.3V Efficiency

425mA. Efficiency curves for the two conditions on I_{PGM} are graphed in Figure 2. Note that all components remain the same for the two curves.

Low Noise Regulator

In some applications, it is important not to introduce any switching noise within the audio frequency range. Due to the Burst Mode nature of the LTC1574, there is a possibility that the regulator will introduce audio noise at some load currents. To circumvent this problem, a feed-forward capacitor can be used to shift the noise spectrum up and out of the audio band. Figure 3 shows the low noise connection with C2 being the feed-forward capacitor. The peak-to-peak output ripple is reduced to 30mV over the entire load range. A toroidal surface mount inductor L1 is chosen for its excellent self-shielding properties. Open magnetic structures such

LT, LTC, LTM, Linear Technology, the Linear logo and Burst Mode are registered trademarks of Linear Technology Corporation. All other trademarks are the property of their respective owners.

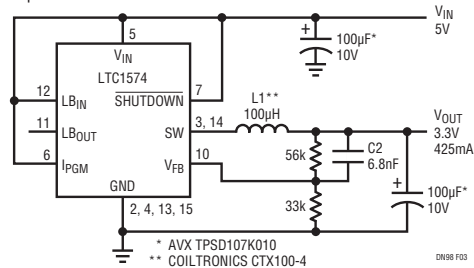

Figure 3. Low Noise 5V to 3.3V Regulator

as drum and rod cores are to be avoided since they inject high flux levels into their surroundings. This can become a major source of noise in any converter circuit.

LTC1265

Whereas the LTC1574 can only supply a load current up to 425mA, the LTC1265 can source up to 1.2A. It features a low 0.3Ω ($V_{IN} = 10V$) internal P-channel MOSFET to provide high efficiency at high load current. The inductor current is user-programmable via an external current sense resistor. Operation up to 700kHz permits the use of small surface mount inductors and capacitors. The LTC1265 employs an external Schottky diode.

Unlike the LTC1574 which always operates in Burst Mode, the LTC1265 only operates in Burst Mode at light loads and switches to continuous operation at heavier loads. For the LTC1265 to operate in Burst Mode, the load current has to be less than $15mV/R_{SENSE}$.

Figure 4 shows a typical LTC1265 surface mount application. It provides 3.3V at 1A from an input voltage

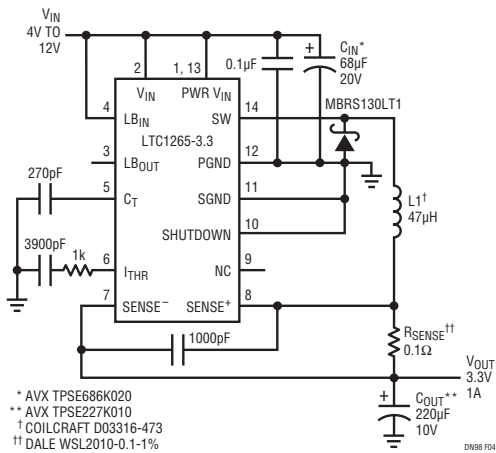

Figure 4. LTC1265 3.3V, 1A Surface Mount

* AVX TPSE686K020
 ** AVX TPSE227K010
 † COILCRAFT D03316-473
 †† DALE WSL2010-0.10-1%

range of 4V to 12V. Efficiency at various input voltages is plotted in Figure 5. Here the sense resistor is chosen as 0.1Ω , therefore the LTC1265 will go into continuous mode operation for load currents greater than 150mA. The peak efficiency approaches 93% at mid-current levels.

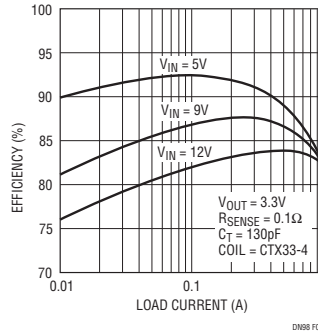

Figure 5. LTC1265 5V to 3.3V Efficiency

Battery Charger Application

In Figure 6, the LTC1265 is configured as a battery charger for a four-NiCd stack. It has the capability of performing a fast charge of 1A, a trickle charge of 100mA or the charger can be shut off. In shut-off, diode D1 serves two purposes. First, it prevents the LTC1265 circuitry from drawing battery current and second, it eliminates “back powering” the LTC1265 which avoids a potential latch condition at power-up.

LTC1574 or LTC1265?

The LTC1574 and LTC1265 are differentiated by both the output current level and operating mode. For loads less than 425mA, the LTC1574 is the ideal choice because of its simplicity and ease of use. However, for applications requiring continuous mode operation, or more than 425mA output current, the LTC1265 must be used. Both devices can be tailored to meet a wide range of requirements.

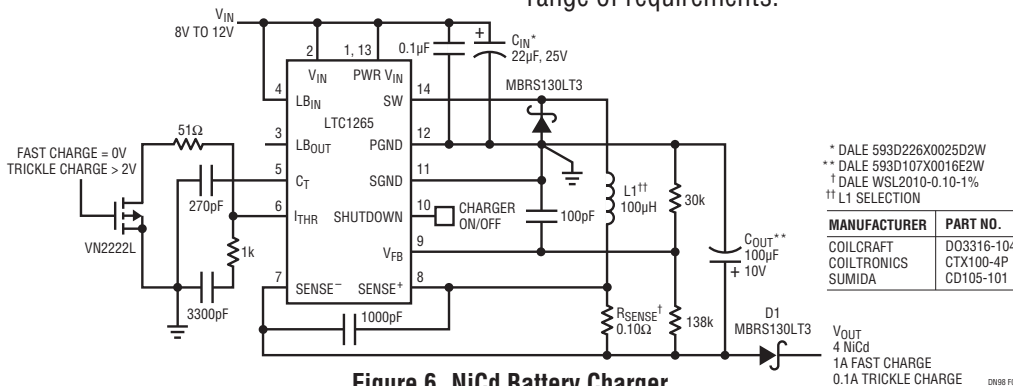

Figure 6. NiCd Battery Charger

* DALE 593D226X0025D2W
 ** DALE 593D107X0016E2W
 † DALE WSL2010-0.10-1%
 †† L1 SELECTION

MANUFACTURER	PART NO.
COILCRAFT	D03316-104
COILTRONICS	CTX100-4P
SUMIDA	CD105-101

VOUT
 4 NiCd
 1A FAST CHARGE
 0.1A TRICKLE CHARGE

Data Sheet Download

www.linear.com

For applications help,
 call (408) 432-1900

Linear Technology Corporation
 1630 McCarthy Blvd., Milpitas, CA 95035-7417
 (408) 432-1900 • FAX: (408) 434-0507 • www.linear.com

dn98f_conv LT/GP 0395 190K • PRINTED IN THE USA

LINEAR
 TECHNOLOGY
 © LINEAR TECHNOLOGY CORPORATION 1995