

18-Bit, 2.5MSPS SAR ADC 100dB SNR

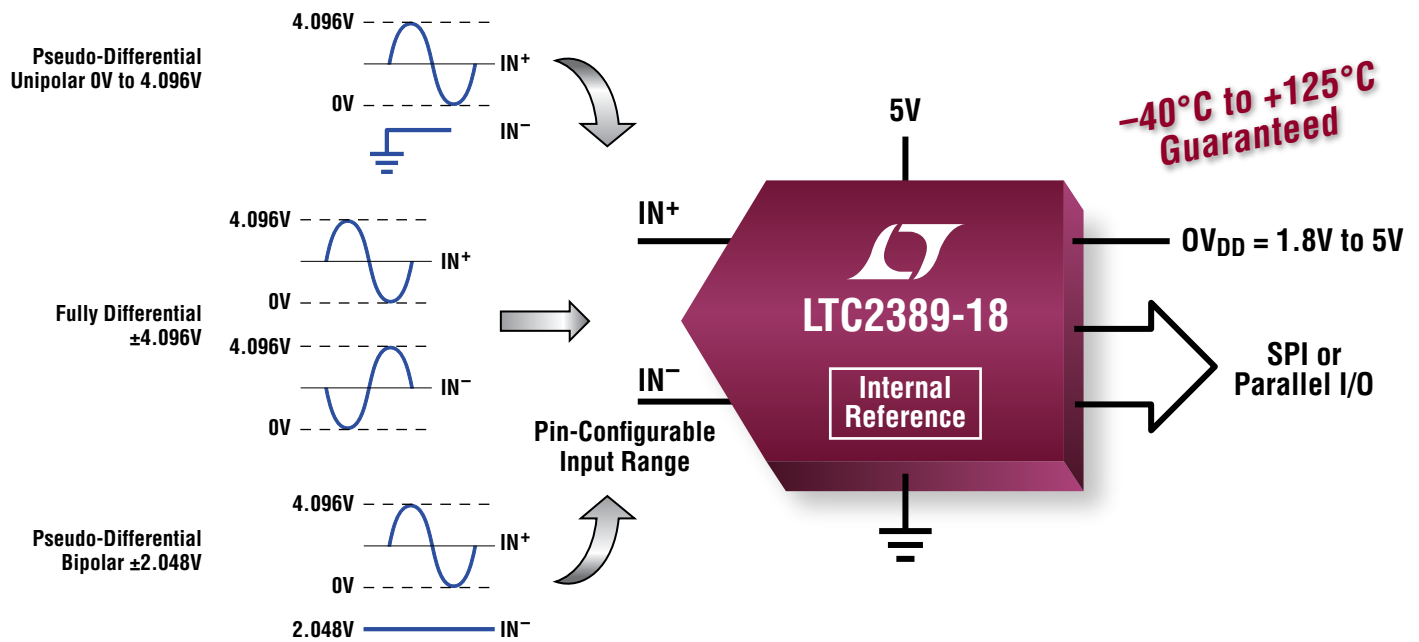

Pin-Configurable Fully Differential or Pseudo-Differential Input Range

Features

- 18-Bit/16-Bit No Latency, 2.5MSPS Pin- and Timing-Compatible SAR ADCs
- Wide $\pm 4.096V$ Fully Differential Inputs Maximize Dynamic Range to Achieve 100dB SNR Performance
- Pin-Configurable Input Ranges $\pm 4.096V$, $\pm 2.048V$ or 0V to 4.096V Allow Flexibility in the Input Signal Chain
- Precision DC Specifications Feature $\pm 3\text{LSB}$ INL (Max) and 18 Bits No Missing Codes Resolution
- Precision 20ppm/°C (Max) Internal Reference and Reference Buffer Reduce External Components and Save Board Space

18-Bit/16-Bit Pin-Compatible Serial/Parallel I/O SAR ADCs

	2.5MSPS	SNR	Power Consumption	Packages
18-Bit		100dB	162.5mW	48-Pin 7mm x 7mm LQFP and QFN
16-Bit		96dB	162.5mW	





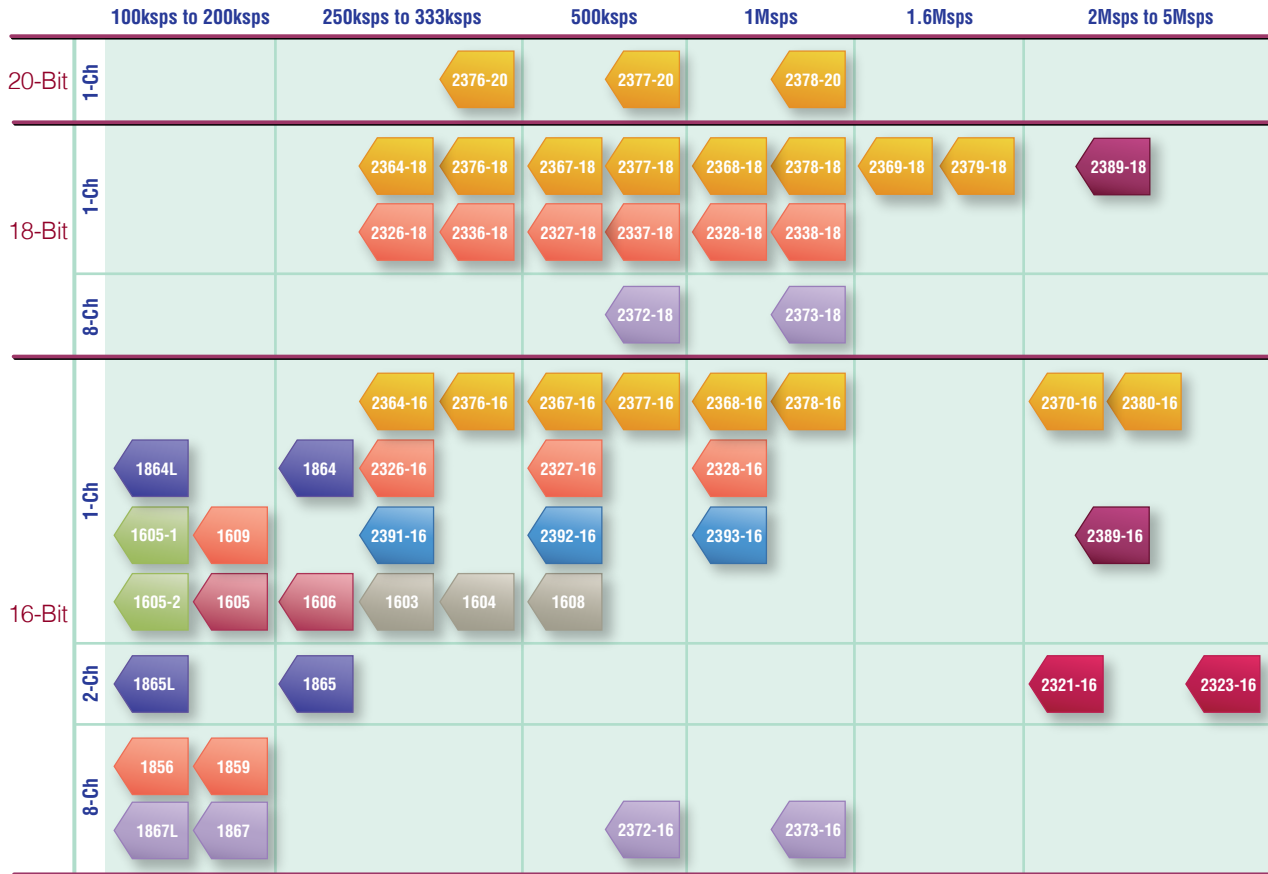

LT, LT, LTC, LTM, Linear Technology and the Linear logo are registered trademarks of Linear Technology Corporation. All other trademarks are the property of their respective owners.

High Precision SAR ADCs



16-Bit to 20-Bit Resolution, 100ksps Up to 5Msps



Serial

-  Pseudo- or Fully Differential Pin-Compatible ADCs
-  ±10V True Bipolar Inputs
-  3V/5V Supply μ Power ADCs
-  3.3V/5V Supply Simultaneous

Serial/Parallel

-  Pseudo- or Fully Differential Pin-Compatible ADCs
-  Fully Differential Pin-Compatible ADCs

Parallel

-  ±10V True Bipolar Inputs
-  0V to 4V, ±4V Unipolar/True Bipolar Inputs
-  ±2.5V True Bipolar Inputs