

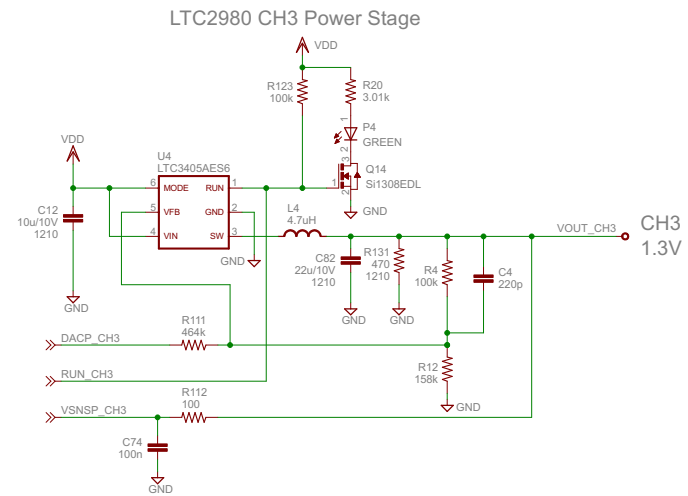

REVISION HISTORY				
ECO	REV	DESCRIPTION	APPROVED	DATE
-	1	PRODUCTION	MIKE P.	01-17-14

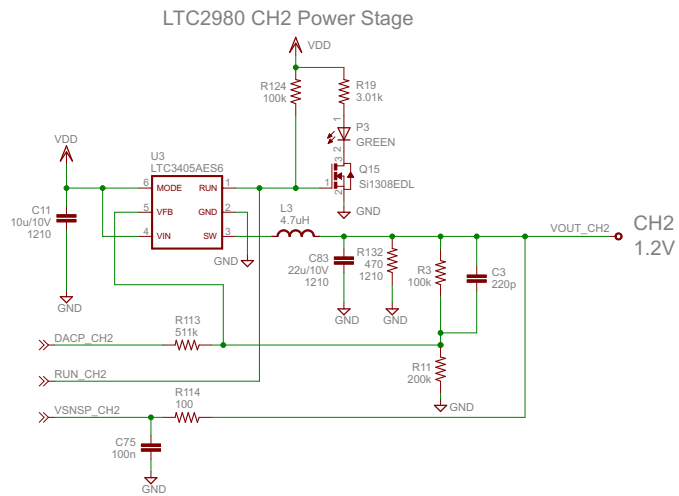
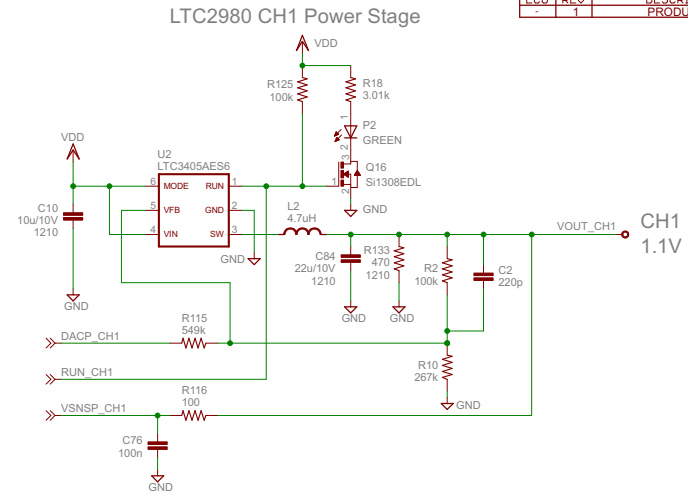
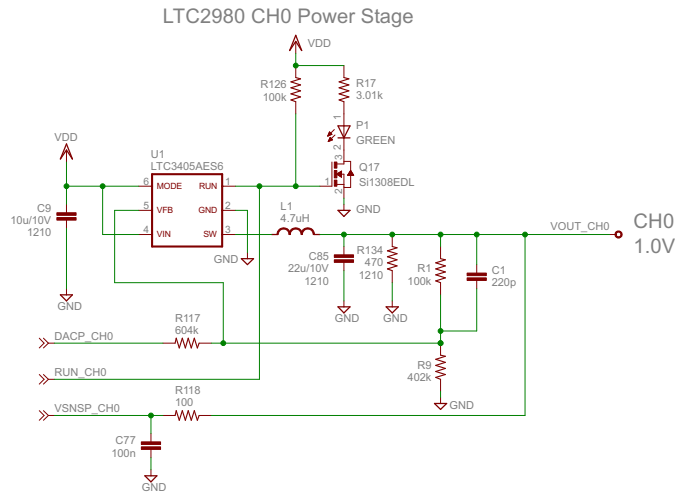

- NOTES: UNLESS OTHERWISE SPECIFIED:
1. ALL RESISTORS ARE 1% 0603.
 2. ALL CAPACITORS ARE 16V 0603.
 3. THE INTERMEDIATE BUS IS VDD=5.0V

CUSTOMER NOTICE		APPROVALS		 <small>1530 McCarthy Blvd. Milpitas, CA 95035 Phone (408) 432-1980 Fax (408) 434-9957 www.linear.com</small>	<small>LTC CONFIDENTIAL FOR CUSTOMER USE ONLY</small>
<small>LINEAR TECHNOLOGY HAS MADE A BEST EFFORT TO DESIGN A CIRCUIT THAT MEETS CUSTOMER-SUPPLIED SPECIFICATIONS; HOWEVER, IT REMAINS THE CUSTOMER'S RESPONSIBILITY TO VERIFY PROPER AND RELIABLE OPERATION IN THE ACTUAL APPLICATION. COMPONENT SUBSTITUTION AND PRINTED CIRCUIT BOARD LAYOUT MAY SIGNIFICANTLY AFFECT CIRCUIT PERFORMANCE OR RELIABILITY. CONTACT LINEAR TECHNOLOGY APPLICATIONS ENGINEERING FOR ASSISTANCE.</small> <small>THIS CIRCUIT IS PROPRIETARY TO LINEAR TECHNOLOGY AND SUPPLIED FOR USE WITH LINEAR TECHNOLOGY PARTS</small>		PCB DES.	R. S.		
		APP ENG.	MIKE P.	SIZE B	IC NO. LTC2980 DEMO CIRCUIT 2198A
		SCALE = NONE	DATE: not saved!	SHEET: 1/6	

REVISION HISTORY				
ECO	REV	DESCRIPTION	APPROVED	DATE
-	1	PRODUCTION	MIKE P.	01-17-14

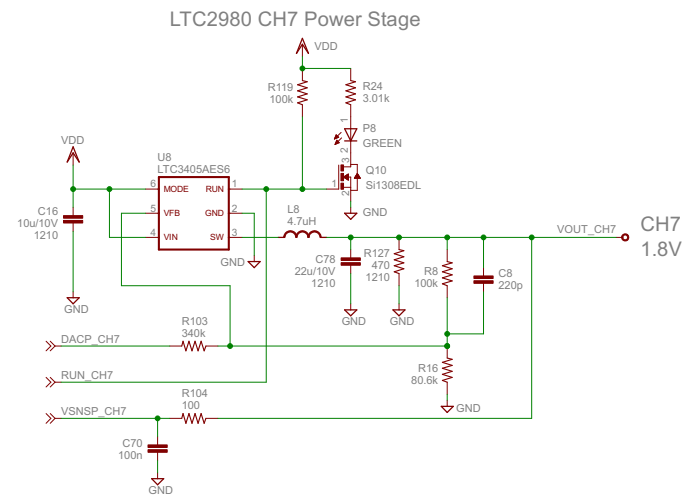
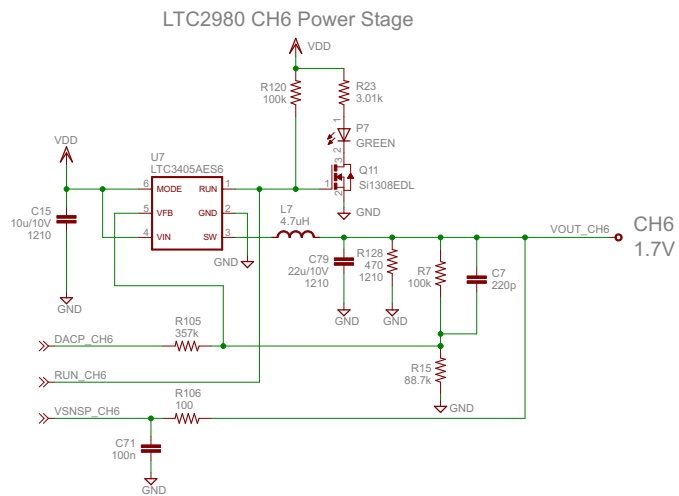
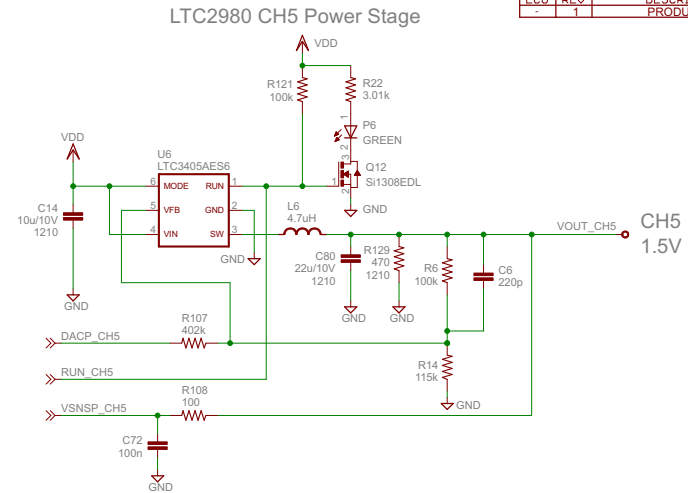
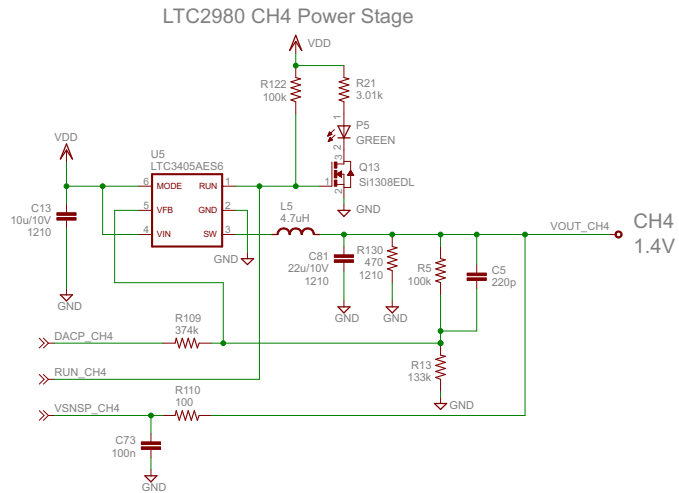

- NOTES: UNLESS OTHERWISE SPECIFIED:**
1. ALL RESISTORS ARE 1% 0603.
 2. ALL CAPACITORS ARE 16V 0603.
 3. THE INTERMEDIATE BUS IS VDD=5.0V

CUSTOMER NOTICE		APPROVALS		 <small>1538 McCarthy Blvd. Milpitas, CA 95035 Phone (408) 432-1980 Fax (408) 434-9957 www.linear.com</small>	<small>LTC CONFIDENTIAL FOR CUSTOMER USE ONLY</small>
<small>LINEAR TECHNOLOGY HAS MADE A BEST EFFORT TO DESIGN A CIRCUIT THAT MEETS CUSTOMER-SUPPLIED SPECIFICATIONS; HOWEVER, IT REMAINS THE CUSTOMER'S RESPONSIBILITY TO VERIFY PROPER AND RELIABLE OPERATION IN THE ACTUAL APPLICATION. COMPONENT SUBSTITUTION AND PRINTED CIRCUIT BOARD LAYOUT MAY SIGNIFICANTLY AFFECT CIRCUIT PERFORMANCE OR RELIABILITY. CONTACT LINEAR TECHNOLOGY APPLICATIONS ENGINEERING FOR ASSISTANCE.</small>		PCB DES.	R. S.		
<small>THIS CIRCUIT IS PROPRIETARY TO LINEAR TECHNOLOGY AND SUPPLIED FOR USE WITH LINEAR TECHNOLOGY PARTS</small>		APP ENG.	MIKE P.	SIZE B	IC NO. LTC2980 DEMO CIRCUIT 2198A
SCALE = NONE		DATE: not saved!		SHEET: 2/6	

REVISION HISTORY				
ECO	REV	DESCRIPTION	APPROVED	DATE
-	1	PRODUCTION	MIKE P.	01-17-14

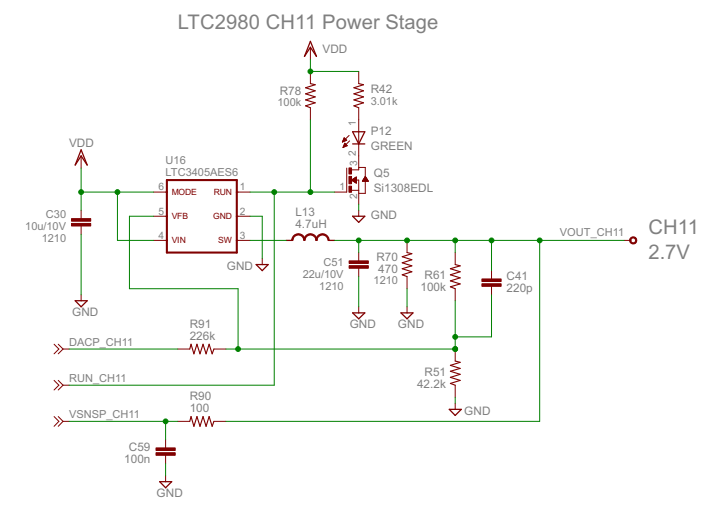
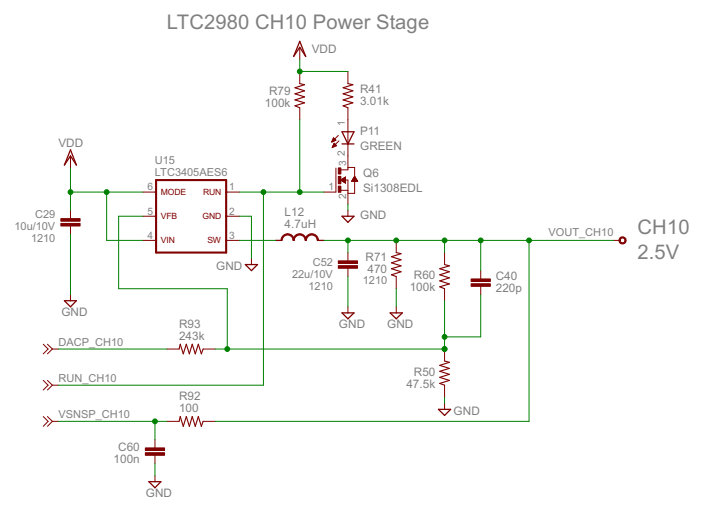
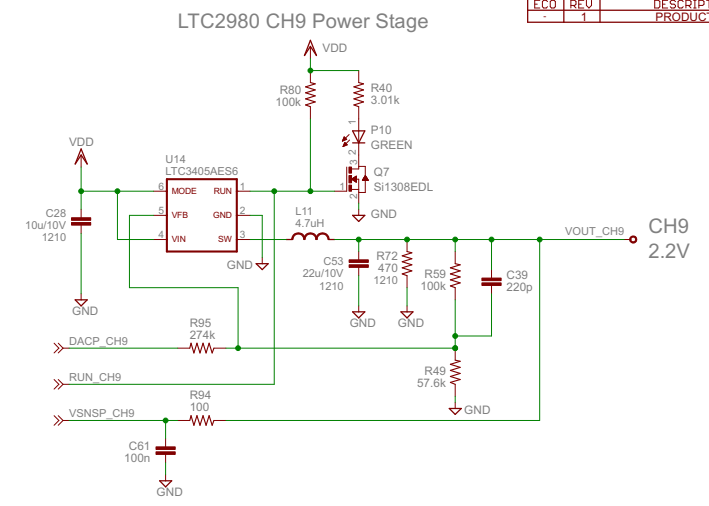
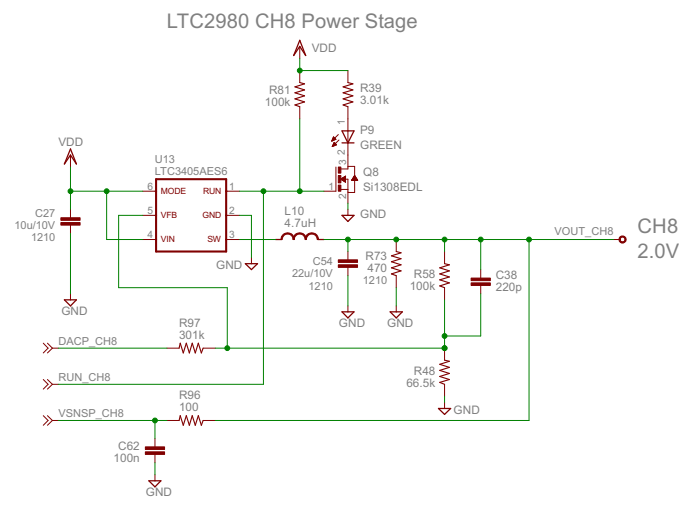

- NOTES: UNLESS OTHERWISE SPECIFIED:**
1. ALL RESISTORS ARE 1% 0603.
 2. ALL CAPACITORS ARE 16V 0603.
 3. THE INTERMEDIATE BUS IS VDD=5.0V

CUSTOMER NOTICE		APPROVALS		 <small>1630 McCarthy Blvd. Millsis, CA 95035 Phone (408) 432-1980 Fax (408) 434-9957 www.linear.com</small>	<small>LTC CONFIDENTIAL FOR CUSTOMER USE ONLY</small>
<small>LINEAR TECHNOLOGY HAS MADE A BEST EFFORT TO DESIGN A CIRCUIT THAT MEETS CUSTOMER-SUPPLIED SPECIFICATIONS; HOWEVER, IT REMAINS THE CUSTOMERS RESPONSIBILITY TO VERIFY PROPER AND RELIABLE OPERATION IN THE ACTUAL APPLICATION. COMPONENT SUBSTITUTION AND PRINTED CIRCUIT BOARD LAYOUT MAY SIGNIFICANTLY AFFECT CIRCUIT PERFORMANCE OR RELIABILITY. CONTACT LINEAR TECHNOLOGY APPLICATIONS ENGINEERING FOR ASSISTANCE.</small>		PCB DES.	R. S.		
<small>THIS CIRCUIT IS PROPRIETARY TO LINEAR TECHNOLOGY AND SUPPLIED FOR USE WITH LINEAR TECHNOLOGY PARTS</small>		APP ENG.	MIKE P.	<small>SIZE B</small>	<small>IC NO. LTC2980 DEMO CIRCUIT 2198A</small>
<small>SCALE = NONE</small>		<small>DATE: not saved!</small>		<small>SHEET: 3/6</small>	

REVISION HISTORY				
ECO	REV	DESCRIPTION	APPROVED	DATE
-	1	PRODUCTION	MIKE P.	01-17-14

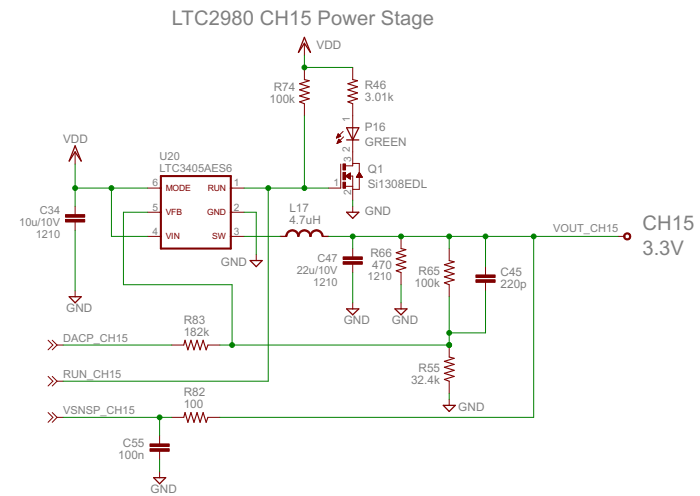
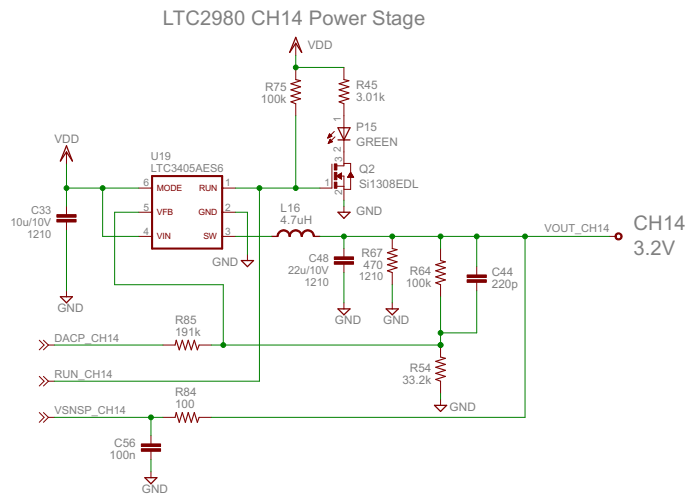
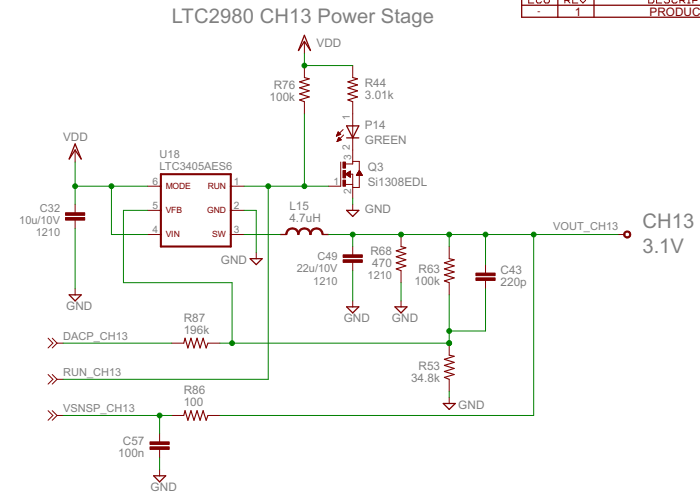
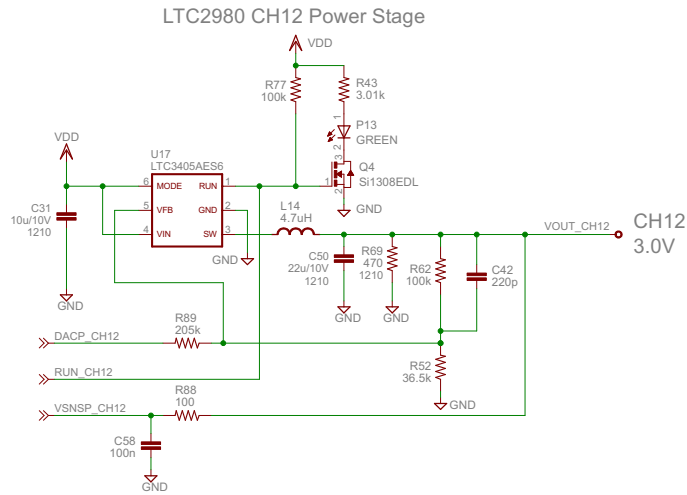

- NOTES: UNLESS OTHERWISE SPECIFIED:
1. ALL RESISTORS ARE 1% 0603.
 2. ALL CAPACITORS ARE 16V 0603.
 3. THE INTERMEDIATE BUS IS VDD=5.0V

CUSTOMER NOTICE		APPROVALS		 <small>1538 McCarthy Blvd. Milpitas, CA 95035 Phone (408) 432-1980 Fax (408) 434-9957 www.linear.com</small>	<small>LTC CONFIDENTIAL FOR CUSTOMER USE ONLY</small>
<small>LINEAR TECHNOLOGY HAS MADE A BEST EFFORT TO DESIGN A CIRCUIT THAT MEETS CUSTOMER-SUPPLIED SPECIFICATIONS; HOWEVER, IT REMAINS THE CUSTOMER'S RESPONSIBILITY TO VERIFY PROPER AND RELIABLE OPERATION IN THE ACTUAL APPLICATION. COMPONENT SUBSTITUTION AND PRINTED CIRCUIT BOARD LAYOUT MAY SIGNIFICANTLY AFFECT CIRCUIT PERFORMANCE OR RELIABILITY. CONTACT LINEAR TECHNOLOGY APPLICATIONS ENGINEERING FOR ASSISTANCE.</small>		PCB DES.	R. S.		
<small>THIS CIRCUIT IS PROPRIETARY TO LINEAR TECHNOLOGY AND SUPPLIED FOR USE WITH LINEAR TECHNOLOGY PARTS</small>		APP ENG.	MIKE P.	SIZE B	IC NO. LTC2980 DEMO CIRCUIT 2198A
SCALE = NONE		DATE: not saved!		SHEET: 4/6	

REVISION HISTORY				
ECO	REV	DESCRIPTION	APPROVED	DATE
-	1	PRODUCTION	MIKE P.	01-17-14

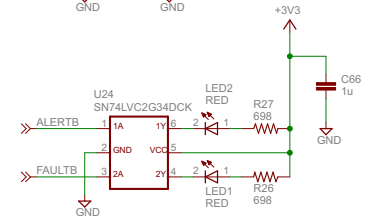
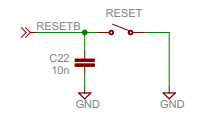
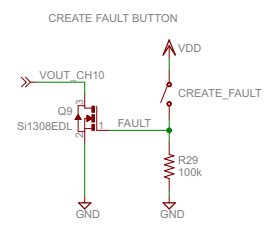
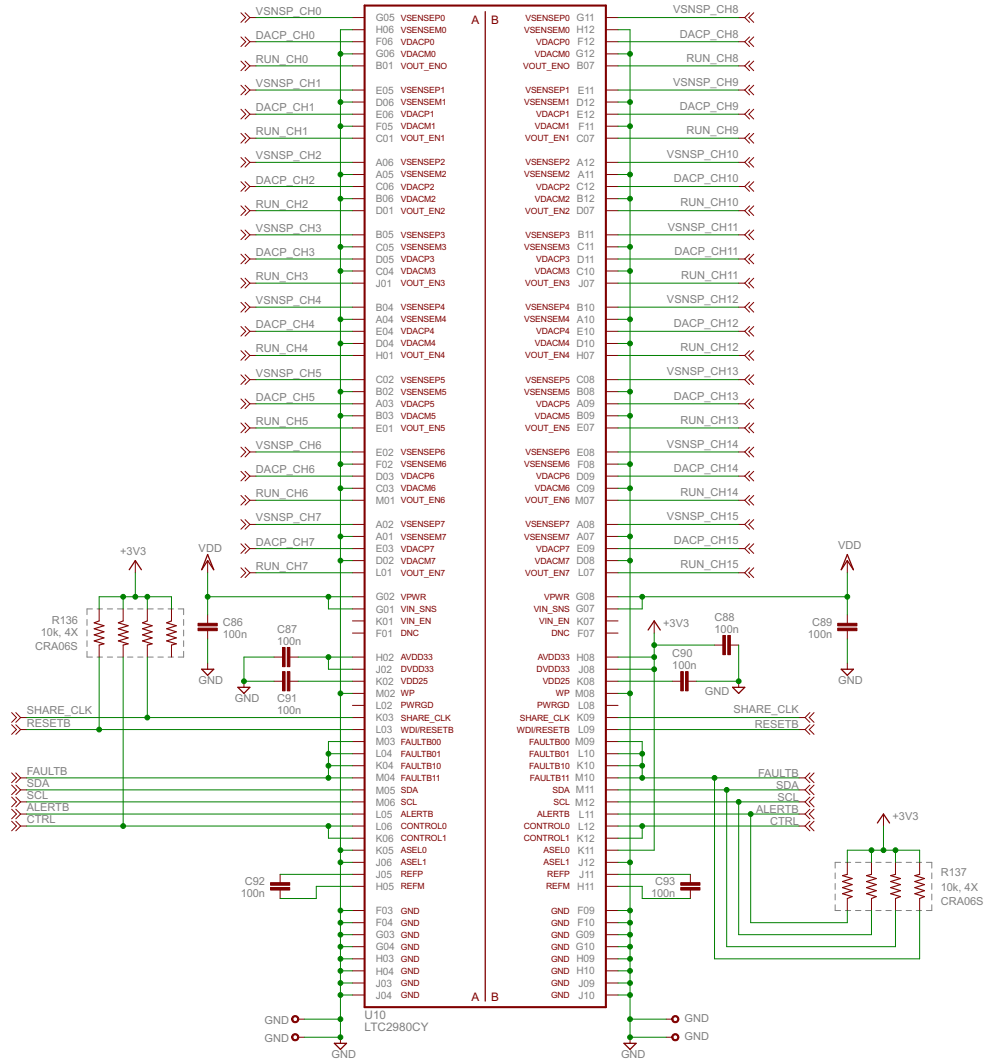

- NOTES: UNLESS OTHERWISE SPECIFIED:
1. ALL RESISTORS ARE 1% 0603.
 2. ALL CAPACITORS ARE 16V 0603.
 3. THE INTERMEDIATE BUS IS VDD=5.0V

CUSTOMER NOTICE		APPROVALS			1438 McCarthy Blvd. Milpitas, CA 95035 Phone: (408) 432-1980 Fax: (408) 434-9957 www.linear.com	LTC CONFIDENTIAL FOR CUSTOMER USE ONLY
LINEAR TECHNOLOGY HAS MADE A BEST EFFORT TO DESIGN A CIRCUIT THAT MEETS CUSTOMER-SUPPLIED SPECIFICATIONS; HOWEVER, IT REMAINS THE CUSTOMER'S RESPONSIBILITY TO VERIFY PROPER AND RELIABLE OPERATION IN THE ACTUAL APPLICATION. COMPONENT SUBSTITUTION AND PRINTED CIRCUIT BOARD LAYOUT MAY SIGNIFICANTLY AFFECT CIRCUIT PERFORMANCE OR RELIABILITY. CONTACT LINEAR TECHNOLOGY APPLICATIONS ENGINEERING FOR ASSISTANCE.		PCB DES.	R. S.			
THIS CIRCUIT IS PROPRIETARY TO LINEAR TECHNOLOGY AND SUPPLIED FOR USE WITH LINEAR TECHNOLOGY PARTS		APP ENG.	MIKE P.	SIZE B	IC NO. LTC2980	REV: 1
		SCALE = NONE	DATE: not saved!	DEMO CIRCUIT 2198A		SHEET: 5/6

REVISION HISTORY			
ECO	REV	DESCRIPTION	DATE
-	1	PRODUCTION	01-17-14

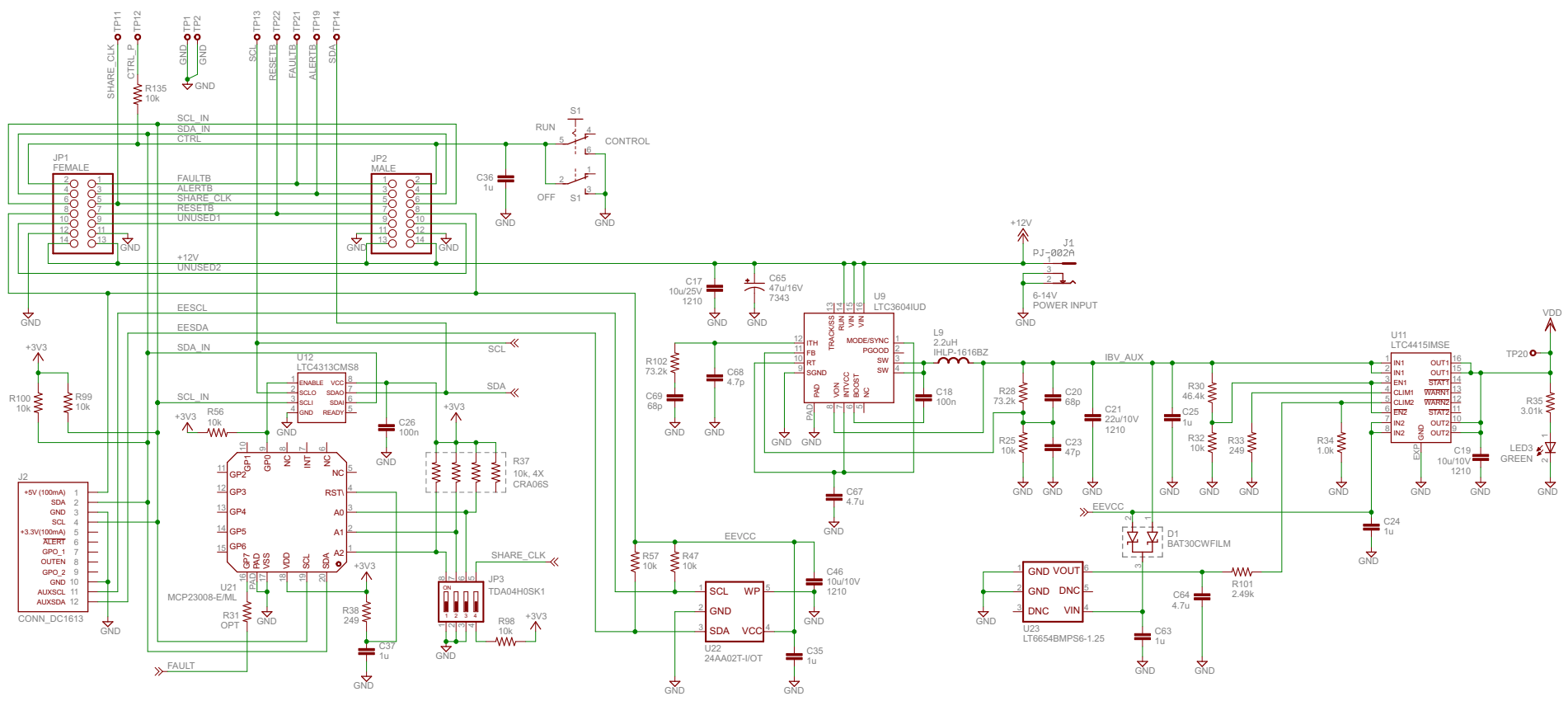

- NOTES: UNLESS OTHERWISE SPECIFIED:
1. ALL RESISTORS ARE 1% 0603.
 2. ALL CAPACITORS ARE 16V 0603.
 3. THE INTERMEDIATE BUS IS VDD=5.0V

CUSTOMER NOTICE		APPROVALS		 1530 McCarthy Blvd. Milpitas, CA 95035 Phone (408) 432-1980 Fax (408) 434-9957 www.linear.com	LTC CONFIDENTIAL FOR CUSTOMER USE ONLY
LINEAR TECHNOLOGY HAS MADE A BEST EFFORT TO DESIGN A CIRCUIT THAT MEETS CUSTOMER-SUPPLIED SPECIFICATIONS; HOWEVER, IT REMAINS THE CUSTOMER'S RESPONSIBILITY TO VERIFY PROPER AND RELIABLE OPERATION IN THE ACTUAL APPLICATION. COMPONENT SUBSTITUTION AND PRINTED CIRCUIT BOARD LAYOUT MAY SIGNIFICANTLY AFFECT CIRCUIT PERFORMANCE OR RELIABILITY. CONTACT LINEAR TECHNOLOGY APPLICATIONS ENGINEERING FOR ASSISTANCE. THIS CIRCUIT IS PROPRIETARY TO LINEAR TECHNOLOGY AND SUPPLIED FOR USE WITH LINEAR TECHNOLOGY PARTS.		PCB DES.	R. S.		
		APP ENG.	MIKE P.	SCALE = NONE	SHEET: 6/6