

High Linearity Components Simplify Direct Conversion Receiver Designs – Design Note 418

Cheng-Wei Pei

Introduction

A direct conversion radio receiver takes a high frequency input signal, often in the 800MHz to 3GHz frequency range, and utilizes one mixer/demodulator stage to convert the signal to baseband without going through an intermediate frequency (IF) stage. The resulting low frequency (baseband) signal spectrum has useful information at frequencies from DC to typically a few tens of MHz. Designing these receivers requires the use of very high performance analog ICs. High performance direct conversion radio receiver signal chains for applications such as cellular infrastructure and RFID readers require high linearity, low noise figure (NF), and good matching between the in-phase and quadrature (I and Q) channels.

The Right Components for the Job

Linear Technology's LT[®]5575 direct conversion demodulator has a combination of excellent linearity and noise performance. The most important linearity specification for direct conversion mixers is the 2nd order intercept point (IIP2) due to the 2nd order distortion product falling within the baseband output spectrum, and the LT5575 boasts 54.1dBm at 900MHz (60dBm at 1900MHz). The

LT5575 also has high 3rd order linearity and a low noise figure of 12.8dB.

The LTC[®]6406 is a fully differential amplifier with low noise (1.6nV/ $\sqrt{\text{Hz}}$ at the input) and high linearity (+44dBm OIP3 at 20MHz) in a small 3mm x 3mm QFN package. External resistors set the gain, giving the user maximum design flexibility. The low power consumption (59mW with a 3.3V supply) means that using two amplifiers for I and Q has minimal effect on the system power budget. The LTC6406 maintains high linearity up to 50MHz, which is perfect for WCDMA receivers and other wideband applications.

A Basic Receiver Design

One common design challenge when using active demodulators is level-shifting the outputs, which can have a DC level close to V_{CC} , to a usable DC level within the input range of the analog-to-digital converter (ADC). Fortunately, the LTC6406's rail-to-rail inputs make interfacing with the outputs of the LT5575 simple and direct. The LTC6406 also includes an extra feedback loop (controlled

LT, LTC, LT and LTM are registered trademarks of Linear Technology Corporation. All other trademarks are the property of their respective owners.

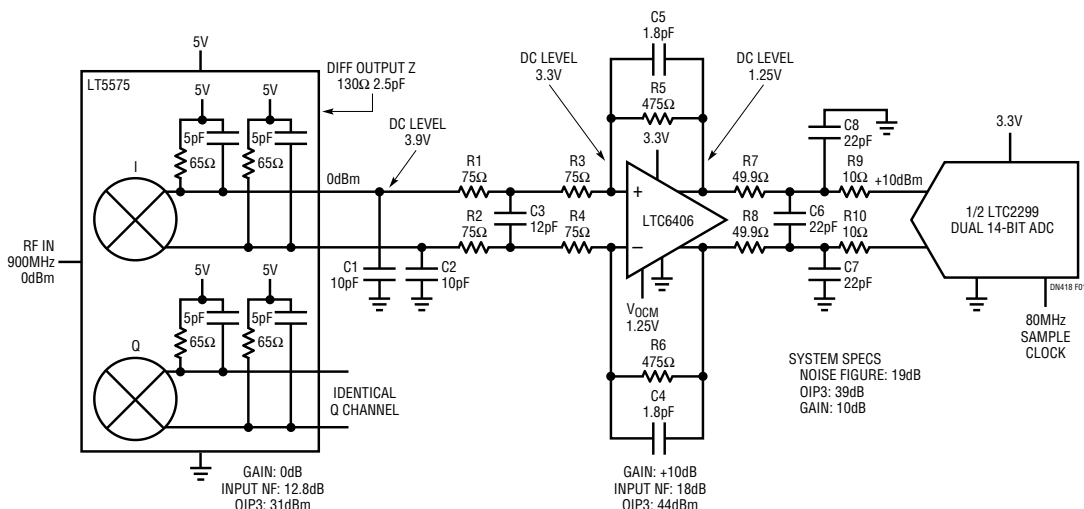

Figure 1. The LT5575 Demodulator and LTC6406 Amplifier Driving an LTC2299 14-Bit ADC. System Bandwidth is Approximately 40MHz. Overall System OIP3 was Measured to be 39dBm

by an external V_{OCM} voltage) that independently sets the output common mode DC level, regardless of the input voltage.

Figure 1 shows a basic receiver circuit with the LT5575 demodulator and the LTC6406 followed by an LTC2299 14-bit ADC. An RC lowpass filter at the output of the demodulator filters undesired out-of-band signals, and another RC lowpass filter before the ADC antialiases and limits noise bandwidth. The DC voltage at the LTC6406 inputs is 3.3V, the same as the supply voltage.

Adding Free Gain to the System

For signal chains that require more gain, the LTC6401-8 differential amplifier/ADC driver is a good complement to the LT5575 and LTC6406. The LTC6401-8 has higher linearity (50dBm OIP3 at 20MHz) and 2.5nV/ $\sqrt{\text{Hz}}$ of input noise in a 3mm \times 3mm QFN package. It contributes gain and linearity without significantly impacting the noise figure. Figure 2 adds the LTC6401-8 (also available in 14dB, 20dB and 26dB flavors) to the signal chain to drive the LTC2299. The higher linearity of the LTC6401-8 increases the combined system OIP3 to 45dBm. In addition, 8dB of gain is added with no significant degradation to the noise figure. The 400 Ω input impedance of the LTC6401-8 is not a heavy load for the LTC6406, which enables direct coupling of the two amplifiers with minimal signal loss (from series resistors, etc.).

A More Selective Filter

There are three places where a filter can be implemented in the circuit of Figure 2: after the mixer, in between the two amplifier stages, and prior to the ADC. Each has its trade-offs, but the simplest design places the filter after the mixer. This topology attenuates unwanted signals earlier in the signal chain, which preserves the IP3 of the following stages and allows for more gain through the system. An LC filter at the demodulator output minimally affects the distortion and noise figure of the system, whereas LC lowpass filters can present a heavy load impedance to a feedback amplifier output near their resonant frequencies. For reasons outside the scope of this article, it is tricky to design LC networks at the input of a high speed sampling ADC.

A concern when designing the LC network is the need to preserve the I and Q gain/phase matching of the LT5575 (0.04dB/0.4° mismatch), which necessitates using low tolerance LC components ($\pm 2\%$ inductors and $\pm 5\%$ capacitors). The frequency response and group delay of the system are almost entirely determined by the LC filter.

Conclusion

Signal chain devices that offer high linearity and excellent noise specifications can greatly simplify the design of high frequency receivers—speeding up entire design cycles.

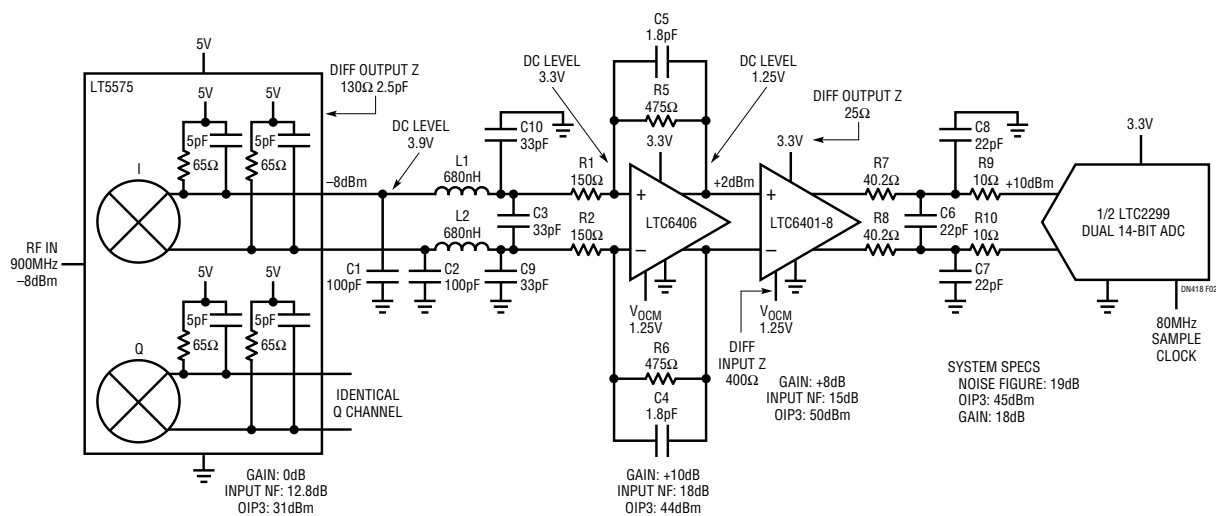

Figure 2. The LT5575 Demodulator with a 20MHz Lowpass Filter followed by LTC6406 and LTC6401-8. System OIP3 is Measured to be 45dBm at 920MHz RF with a 900MHz Local Oscillator. System Noise Figure (NF) Adds up to Approximately 19dB

Data Sheet Download

www.linear.com

For applications help,
call (408) 432-1900, Ext. 2525