

REVISION HISTORY				
ECO	REV	DESCRIPTION	DATE	APPROVED
	1C	PRODUCTION	05/18/21	<i>[Signature]</i>

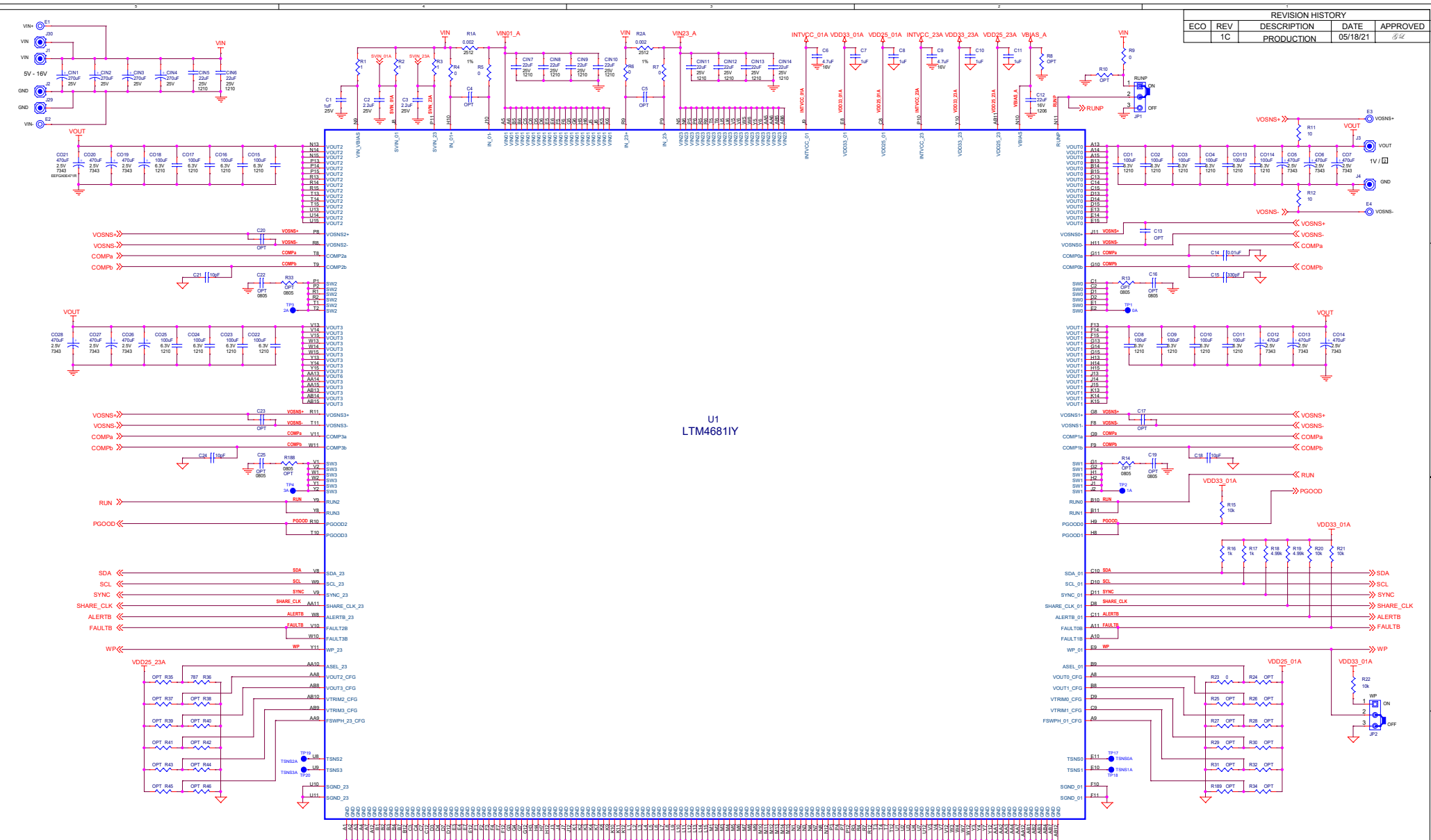

NOTE: UNLESS OTHERWISE SPECIFIED:
 1. ALL RESISTORS ARE 0805
 2. ALL CAPACITORS ARE 0603

VERSION	NUMBER OF LTM4681 USED	MAX OUTPUT CURRENT	DEFAULT VOUT	DEFAULT FSW	C14	C15	NOTE FOR ASSEMBLY
-A	2x LTM4681: U1, U2	240A	1V	350kHz	10nF	330µF	All components listed on page 3 and page 4 of the schematic are option and not stuffed for -A version
-B	3x LTM4681: U1, U2, U3	360A	1V	350kHz	12nF	470µF	All components listed on page 4 of the schematic are option and not stuffed for -B version
-C	4x LTM4681: U1, U2, U3, U4	480A	1V	350kHz	15nF	470µF	

CUSTOMER NOTICE
 ANALOG DEVICES HAS MADE A BEST EFFORT TO DESIGN A CIRCUIT THAT MEETS CUSTOMER'S SPECIFICATIONS. HOWEVER, IT REMAINS THE CUSTOMER'S RESPONSIBILITY TO VERIFY PROPER AND RELIABLE OPERATION IN THE ACTUAL APPLICATION. COMPONENT SUBSTITUTION AND PRINTED CIRCUIT BOARD LAYOUT MAY PRESENTLY AFFECT CIRCUIT PERFORMANCE. WE WILL BE GLAD TO ASSIST CUSTOMER APPLICATIONS ENGINEERS FOR ASSISTANCE.

THIS CIRCUIT IS PROPRIETARY TO ANALOG DEVICES AND SUPPLIED FOR USE WITH ANALOG DEVICES' PRODUCTS.

APPROVALS		ANALOG DEVICES		POWER BY LINEAR	
FOR DES:	<i>[Signature]</i>	www.analog.com		Phone: (408)433-1900	
APP ENG:	<i>[Signature]</i>				
TITLE: SCHEMATIC					
POLYPHASE SINGLE OUTPUT DC/DC PSM					
IMODULE-REGULATOR					
IC NO. LTM4681IY		SKU NO. DC3082A-A		SCHEMATIC NO. AND REVISION: 710-DC3082A-A_REV01C	
SIZE: N/A		DATE: Tuesday, May 18, 2021		SHEET 1 OF 5	

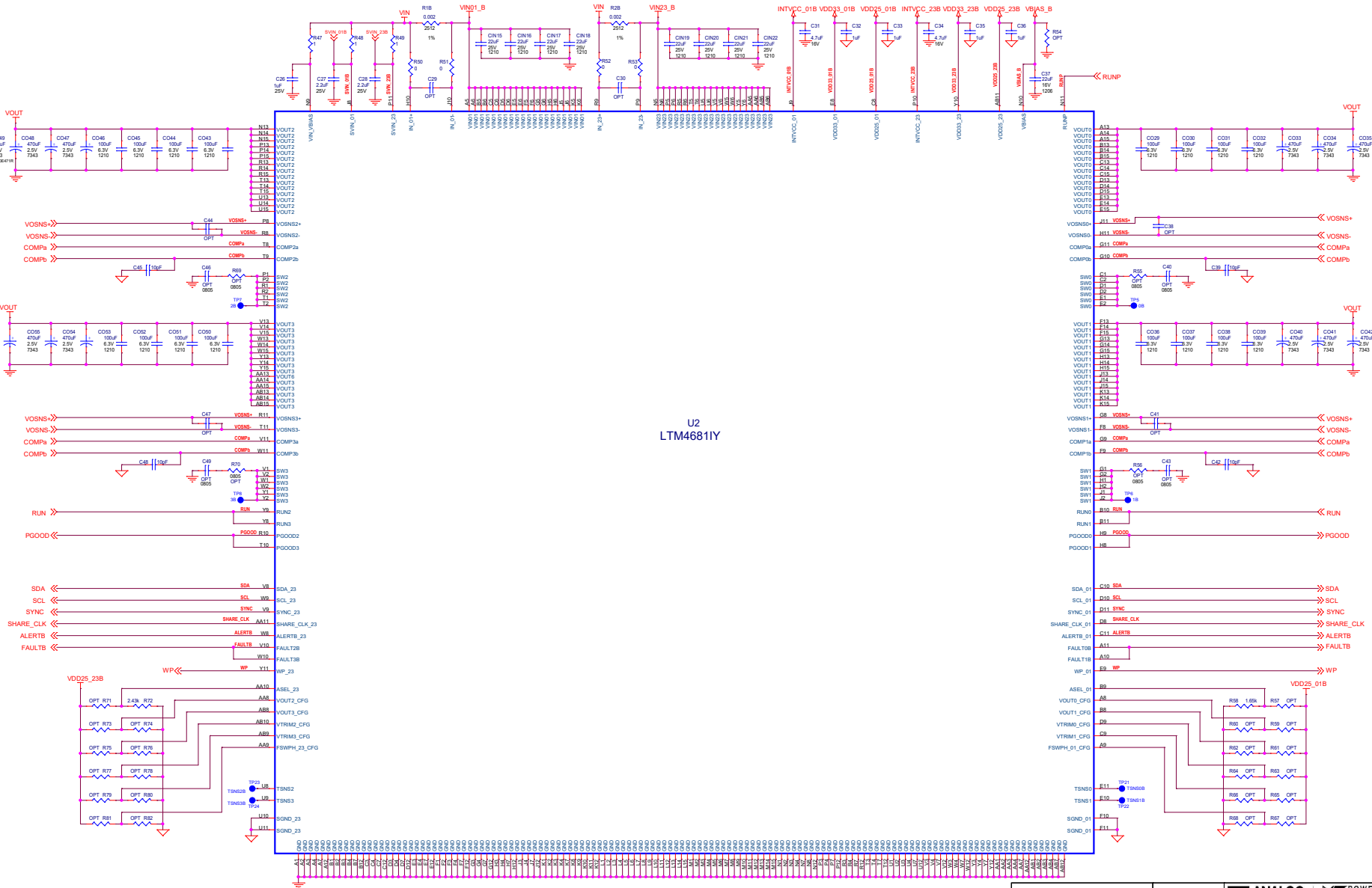

U2
LTM4681Y

CUSTOMER NOTICE		APPROVALS		ANALOG DEVICES		POWER BY LINEAR	
ANALOG DEVICES HAS MADE A BEST EFFORT TO DESIGN A CIRCUIT THAT MEETS CUSTOMER SPECIFICATIONS. HOWEVER, IT REMAINS THE CUSTOMER'S RESPONSIBILITY TO VERIFY PROPER AND RELIABLE OPERATION IN THE ACTUAL APPLICATION. COMPONENT SUBSTITUTION AND PRINTED CIRCUIT BOARD LAYOUT MAY SIGNIFICANTLY AFFECT CIRCUIT PERFORMANCE. SEE RELEASED PRODUCT APPLICATIONS ENGINEERING FOR ASSISTANCE.		FOR DES.	APP	www.analog.com		Phone: (408)432-1900	
THIS CIRCUIT IS PROPRIETARY TO ANALOG DEVICES AND SUPPLIED FOR USE WITH ANALOG DEVICES PRODUCTS.		APP ENG.	BZ	TITLE: SCHEMATIC		POLYPHASE SINGLE OUTPUT DC/DC PSM	
				IC NO. LTM4681Y		SCHEMATIC NO. AND REVISION:	
				SKU NO. DC3082A-A		710-DC3082A-A_REV01C	
				SIZE: N/A		DATE: Tuesday, May 18, 2021	
						SHEET 2 OF 5	

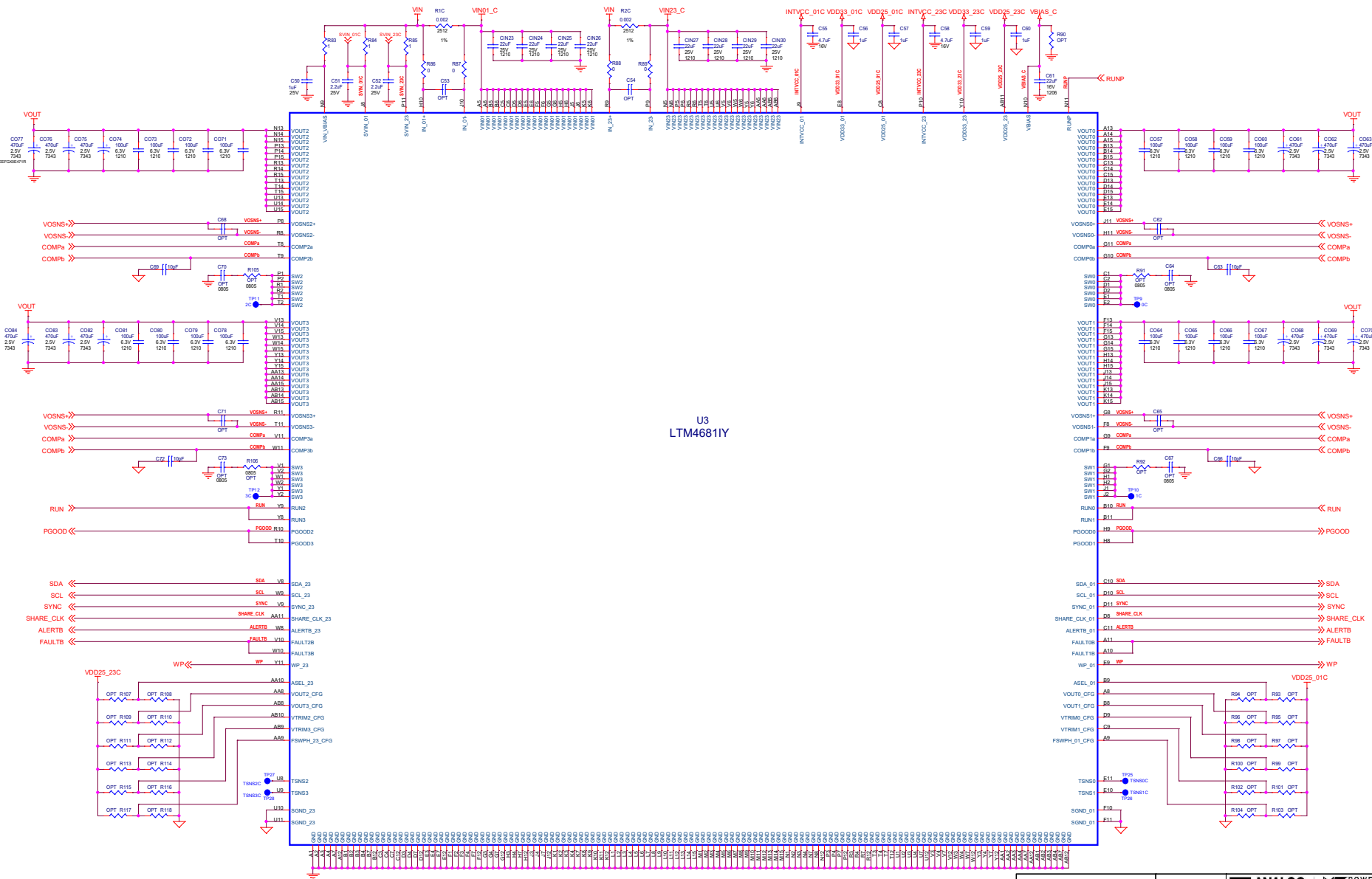

U3
LTM4681Y

CUSTOMER NOTICE		APPROVALS		ANALOG DEVICES		POWER BY LINEAR	
ANALOG DEVICES HAS MADE A BEST EFFORT TO DESIGN A CIRCUIT THAT MEETS CUSTOMER SPECIFICATIONS. HOWEVER, IT REMAINS THE CUSTOMER'S RESPONSIBILITY TO VERIFY PROPER AND RELIABLE OPERATION IN THE ACTUAL APPLICATION. COMPONENT SUBSTITUTION AND PRINTED CIRCUIT BOARD LAYOUT MAY PRESENTLY AFFECT CIRCUIT PERFORMANCE OR RELIABILITY. CONTACT ANALOG DEVICES APPLICATIONS ENGINEERING FOR ASSISTANCE.		FOR DES:	APP	www.analog.com		Phone: (408)432-1900	
		APP ENG:	BZ	TITLE: SCHEMATIC		SCHEMATIC NO. AND REVISION:	
				POLYPHASE SINGLE OUTPUT DC/DC PSM		710-DC3082A-A_REV01C	
				IC NO. LTM4681Y		710-DC3082A-A	
				SKU NO. DC3082A-A		DATE: Tuesday, May 18, 2021	
THIS CIRCUIT IS PROPRIETARY TO ANALOG DEVICES AND SUPPLIED FOR USE WITH ANALOG DEVICES PRODUCTS.				SIZE: N/A		SHEET 3 OF 5	

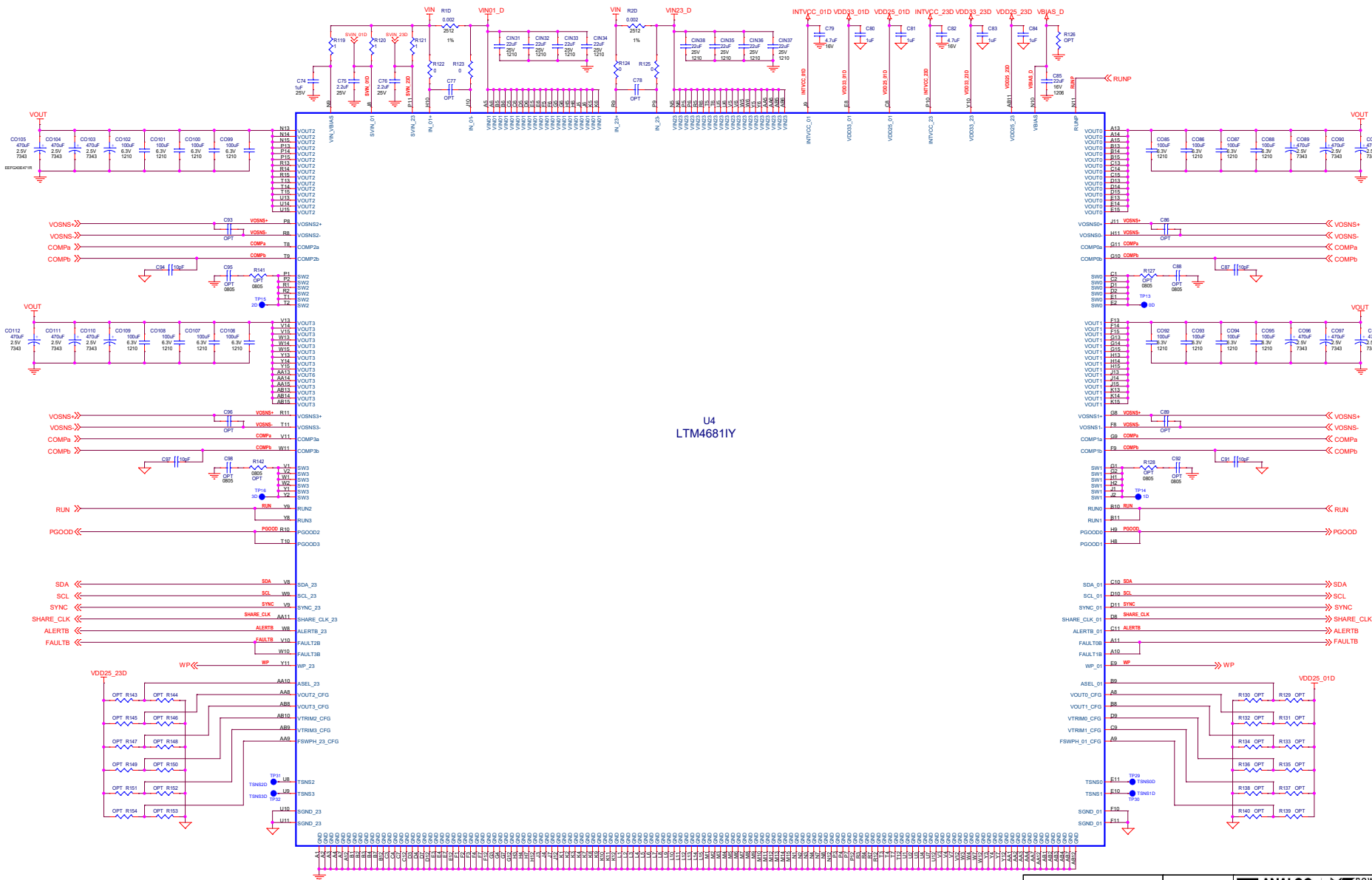

CUSTOMER NOTICE		APPROVALS		ANALOG DEVICES		POWER BY LINEAR	
ANALOG DEVICES HAS MADE A BEST EFFORT TO DESIGN A CIRCUIT THAT MEETS CUSTOMER SPECIFICATIONS. HOWEVER, IT REMAINS THE CUSTOMER'S RESPONSIBILITY TO VERIFY PROPER AND RELIABLE OPERATION IN THE ACTUAL APPLICATION. COMPONENT SUBSTITUTION AND PRINTED CIRCUIT BOARD LAYOUT MAY SIGNIFICANTLY AFFECT CIRCUIT PERFORMANCE. OR, ANALOG DEVICES APPLICATION ENGINEERS FOR ASSISTANCE.		FOR DES.	APP	www.analog.com		Phone: (408)432-1900	
		APP ENG.	B/E	TITLE: SCHEMATIC		SCHEMATIC NO. AND REVISION:	
				POLYPHASE SINGLE OUTPUT DC/DC PSM		710-DC3082A-A_REV01C	
				IC NO. LTM4681Y		SCHEMATIC NO. AND REVISION:	
				SKU NO. DC3082A-A		710-DC3082A-A_REV01C	
				SIZE: N/A		DATE: Tuesday, May 18, 2021	
						SHEET 4 OF 5	

THIS CIRCUIT IS PROPRIETARY TO ANALOG DEVICES AND SUPPLIED FOR USE WITH ANALOG DEVICES PRODUCTS.

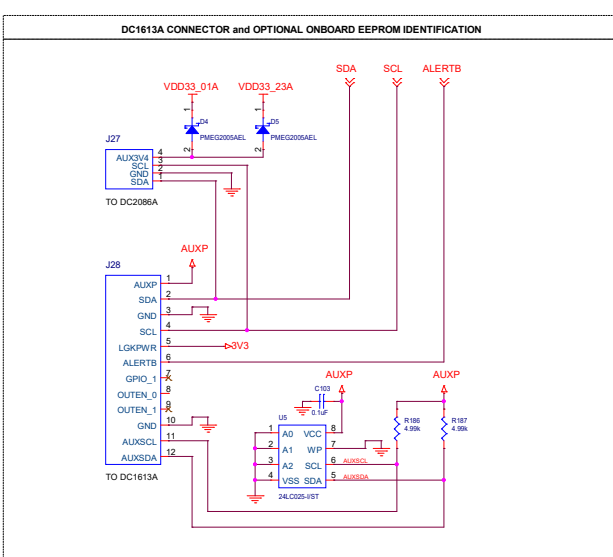
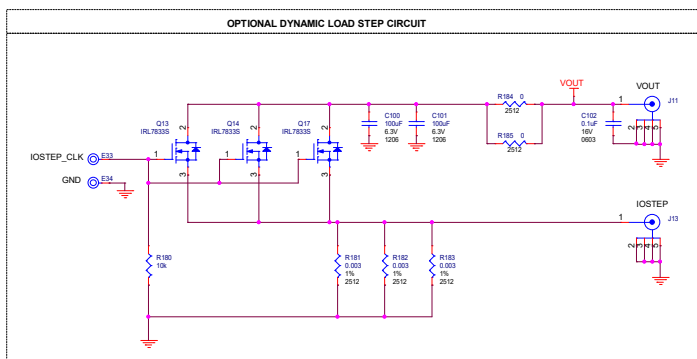
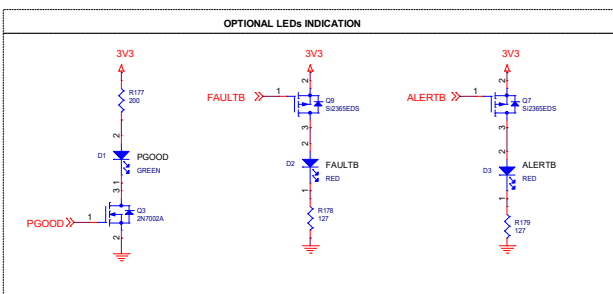
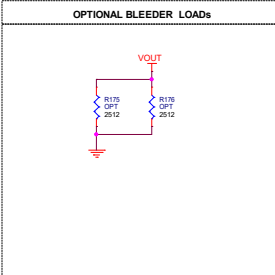
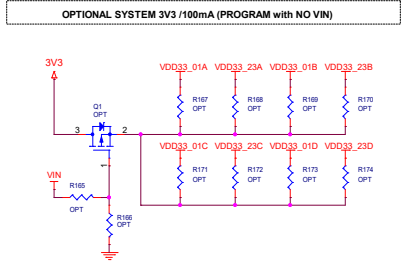
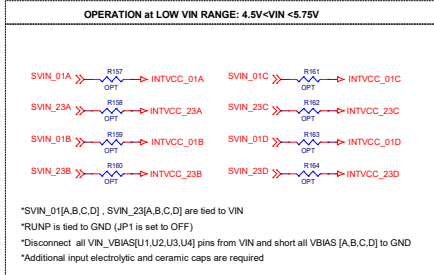
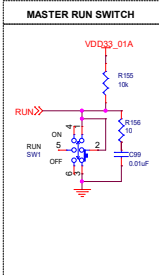
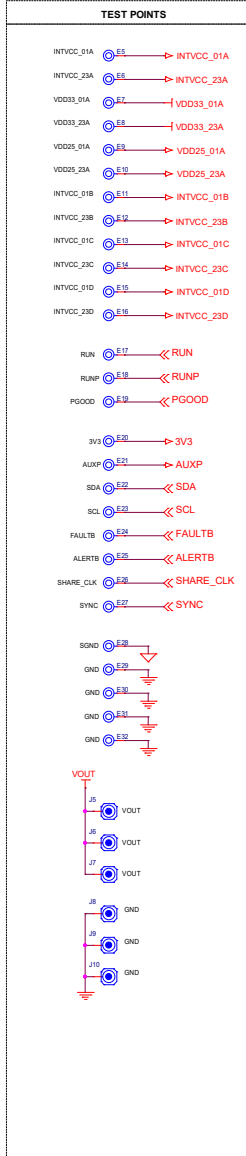

CUSTOMER NOTICE ANALOG DEVICES HAS MADE A BEST EFFORT TO DESIGN A CIRCUIT THAT MEETS CUSTOMER-SPECIFIED SPECIFICATIONS. HOWEVER, IT REMAINS THE CUSTOMER'S RESPONSIBILITY TO VERIFY PROPER AND RELIABLE OPERATION IN THE ACTUAL APPLICATION. COMPONENT SUBSTITUTION AND PRINTED CIRCUIT BOARD LAYOUT MAY SIGNIFICANTLY AFFECT CIRCUIT PERFORMANCE OR RELIABILITY. CONTACT ANALOG DEVICES APPLICATIONS ENGINEERS FOR ASSISTANCE.	APPROVALS FOR DES: <i>ag</i> APP ENG: <i>bl</i>	 www.analog.com Phone: (408)432-1900
	TITLE: SCHEMATIC POLYPHASE SINGLE OUTPUT DC/DC PSM 18MODULE REGULATOR	
THIS CIRCUIT IS PROPRIETARY TO ANALOG DEVICES AND SUPPLIED FOR USE WITH ANALOG DEVICES PRODUCTS.	IC NO. LTM4681TY SKU NO. DC3082A-A	SCHEMATIC NO. AND REVISION: 710-DC3082A-A_REV01C
	SIZE: N/A DATE: Tuesday, May 18, 2021	SHEET 5 OF 5