

This circuit is proprietary to Linear Technology and supplied for use with Linear Technology parts.
Customer Notice: Linear Technology has made a best effort to design a circuit that meets customer-supplied specifications; however, it remains the customers responsibility to verify proper and reliable operation in the actual application, Component substitution and printed circuit board layout may significantly affect circuit performance or reliability. Contact Linear Applications Engineering for assistance.

REVISION HISTORY				
ECO	REV	DESCRIPTION	DATE	APPROVED
	A	PROTO	10/25/07	

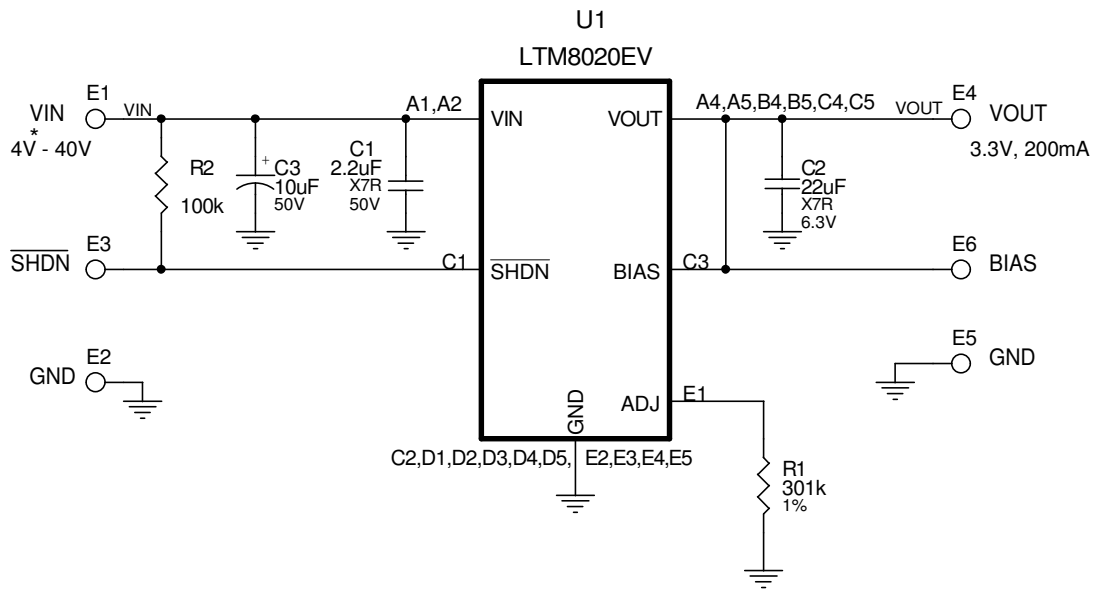

* SEE QUICK-START GUIDE

CONTRACT NO.	
APPROVALS	DATE
DRAWN MEI	11/28/06
CHECKED	
APPROVED	
ENGINEER	
DESIGNER	
Thursday, November 01, 2007	



1630 McCarthy Blvd.
 Milpitas, CA 95035
 Phone: (408)432-1900
 Fax: (408)434-0507

TITLE SCH, LTM8020EV, 200mA DC/DC MICRO MODULE			
SIZE	CAGE CODE	DWG NO DC1194A	REV A
SCALE:	FILENAME: 1194A-2.DSN	SHEET 1	OF 1