



+2.5V Low-Power Precision Voltage Reference

REF43

1.0 SCOPE

This specification documents the detail requirements for space qualified product manufactured on Analog Devices, Inc.'s QML certified line per MIL-PRF-38535 Level V except as modified herein.

The manufacturing flow described in the STANDARD SPACE LEVEL PRODUCTS PROGRAM brochure is to be considered a part of this specification. <http://www.analog.com/aerospace>

This data sheet specifically details the space grade version of this product. A more detailed operational description and a complete data sheet for commercial product grades can be found at www.analog.com/REF43

2.0 Part Number. The complete part number(s) of this specification follow:

Part Number	Description
REF43-803J	+2.5V Low-Power Precision Voltage Reference
REF43-803L	+2.5V Low-Power Precision Voltage Reference
REF43-803RC	+2.5V Low-Power Precision Voltage Reference
REF43-803Z	+2.5V Low-Power Precision Voltage Reference
REF43R803J	Radiation Tested, +2.5V Low-Power Precision Voltage Reference
REF43R803L	Radiation Tested, +2.5V Low-Power Precision Voltage Reference
REF43R803RC	Radiation Tested, +2.5V Low-Power Precision Voltage Reference
REF43R803Z	Radiation Tested, +2.5V Low-Power Precision Voltage Reference

2.1 Case Outline

Letter	Descriptive designator ¹	Case Outline (Lead Finish per MIL-PRF-38535)
J	MACY1-X8	8-Lead Can
L	GDFP1-F10	10-lead cerpac
RC	CQCC1-N20	20-Terminal leadless chip carrier
Z	GDIP1-T8	8-Lead ceramic dual-in-line package (CERDIP)

¹ See MIL-STD-1835

3.0 Absolute Maximum Ratings. (T_A = 25°C, unless otherwise noted)

Supply voltage	40V
Power dissipation.....	500mW
Output short circuit duration	Indefinite
Storage Temperature range.....	-65° to +150°C
Operating temperature range	-55° to +125°C
Lead temperature (soldering, 60 sec)	+300°C
Junction Temperature (T _J)	+175°C

REF43

3.1 Thermal Characteristics:

Package Type	Junction-to-Case (Θ_{JC})	Junction-to-Ambient (Θ_{JA})	Units
J (TO-99 Package)	45	150	°C/W Max
L (CERPAC Package)	22	141	°C/W Max
RC (LCC Package)	35	110	°C/W Max
Z (CERDIP Package)	26	120	°C/W Max

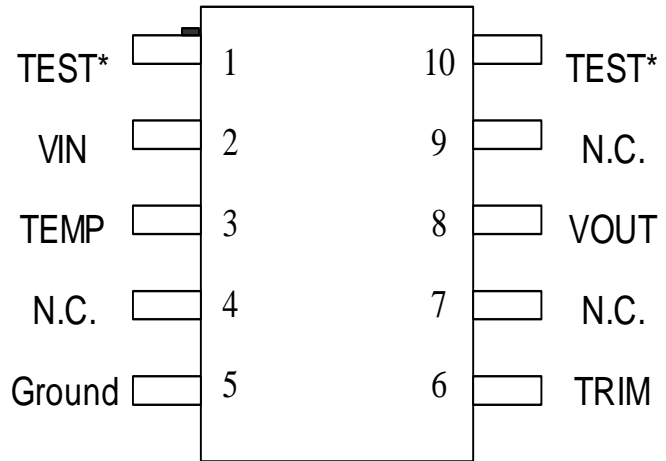
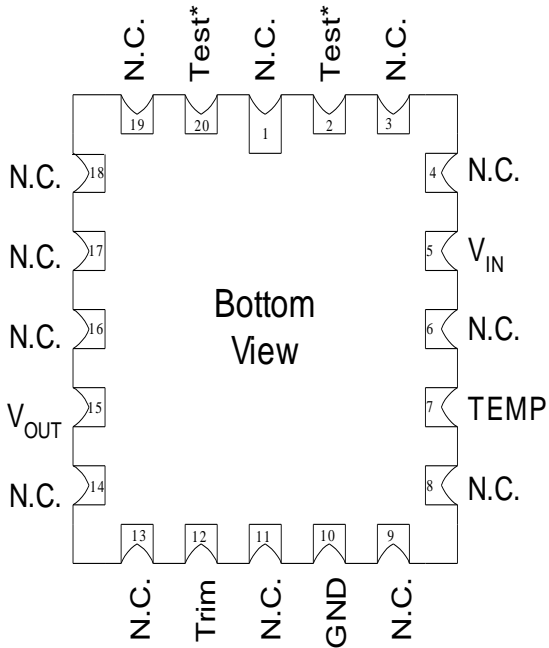
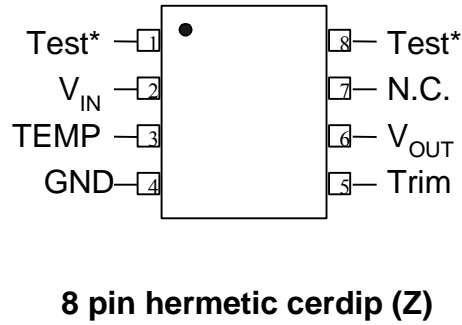
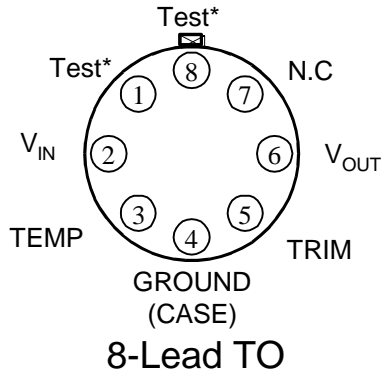

Figure 1 - Terminal connections.

* Reserved for factory testing. Make no electrical connection to these pins.

4.0 Electrical Table: See notes at end of table

Table I								
Parameter	Symbol	Conditions <u>1/</u>	Package	Sub-group	Limit Min	Limit Max	Units	
Output voltage	V_O	ALL	ALL	1	2.4975	2.5025	V	
				2, 3	2.4950	2.5050		
				M, D, L, R	ALL	1		2.4900
Output voltage temperature co-efficient <u>3/</u>	TC_{V_O}	ALL	ALL	8		15	ppm/°C	
Temperature voltage output <u>4/</u>	V_T	ALL	ALL	1	0.54	0.58	V	
				2	0.72	0.78		
				3	0.38	0.43		
Load regulation	LD_{REG}	$I_L = 0mA$ to 10mA	ALL	J, Z	1	20	ppm/mA	
				J, Z, RC	2, 3	40		
				L, RC	1	28		
				L	2, 3	50		
				M, D, L, R	J, Z, RC	1		60
				L	1	70		
Line regulation	LN_{REG}	$V_{IN} = 4.5V$ to 40V	ALL	1	2	ppm/V		
				2, 3	3			
				M, D, L, R	ALL		1	100
Short circuit current <u>4/</u>	I_{SC}	$V_O = 0V$	ALL	1	100	mA		
				2, 3	120			
Supply current	I_{SY}	ALL	ALL	1	450	μA		
				2, 3	600			
				M, D, L, R	ALL		1	450
Output adjustment range <u>4/</u>	ΔV_{TRIM}	ALL	ALL	1	± 3		%	
Load current <u>2/</u>	I_L	ALL	ALL	1, 2, 3	10		mA	
Wideband output noise	enRMS	ALL	ALL	7		10	$\mu VRMS$	

TABLE I NOTES:

- $V_{IN} = 5V$, unless otherwise specified. NOTE: Output decoupling is not generally required or recommended on the REF43. In applications that require output decoupling, care will need to be taken when choosing the capacitor due to the ESR of the capacitor. If capacitors with very low ESR are chosen it may be necessary to add some additional resistance in series with the capacitor to limit the initial charge current when power is applied to the REF43. Adding series resistance when low ESR capacitors are used will help with the stability of the REF43 when power is applied over the entire temperature range. Contact ADI Aerospace applications for more detailed application information.
- Guaranteed by Load regulation test.
- Output voltage temperature coefficient is measured by the box method. The tempco is defined as the slope of the diagonal of a box drawn around the output voltage plotted against temperature. V_{OUT} is measured at T_{MIN} and T_{MAX} . The lowest of these readings is subtracted from the highest reading and the resulting difference is divided by $(T_{MAX} - T_{MIN})$.
- Not tested post-irradiation.

4.1 Electrical Test Requirements:

Table II	
Test Requirements	Subgroups (in accordance with MIL-PRF-38535, Table III)
Interim Electrical Parameters	1
Final Electrical Parameters	1, 2, 3, 8 <u>1/</u> <u>2/</u>
Group A Test Requirements	1, 2, 3, 7, 8
Group C end-point electrical parameters	1 <u>2/</u>
Group D end-point electrical parameters	1
Group E end-point electrical parameters	1

1/ PDA applies to subgroup 1. Delta's excluded from PDA.
 2/ See table III for delta measurement parameters. See Table I for test conditions.

4.2 Table III. Lifetest / Burn-in delta limits.

Table III				
TEST TITLE	BURN-IN ENDPOINT	LIFETEST ENDPOINT	DELTA LIMIT	UNITS
VO	2.50 ±0.0025	2.50 ±0.005	±0.0025	V
ISY	450	495	±45	μA

5.0 Life Test/Burn-In Circuit:

- 5.1 HTRB is not applicable for this drawing.
- 5.2 Burn-in is per MIL-STD-883 Method 1015 test condition B.
- 5.3 Steady state life test is per MIL-STD-883 Method 1005.

Rev	Description of Change	Date
A	Initiate	26-May-00
B	Add subgroup 8 to table II, Add L package, update table III	Mar. 27, 2001
C	Update web address. Table II – delete subgroup 7 from final electrical parameters and add subgroup 7 to Group A Test Requirements.	Feb. 14, 2002
D	Update web address. Delete burn-in circuit.	May 29, 2003
E	Changed CERPAC Load Regulation limit from 20ppm/mA to 28ppm/mA. Add package column on electrical table	Feb. 03, 2005
F	Update Table I Load Regulation specs	April 27, 2006
G	Update Table I Load Regulation specs.	Feb. 13, 2007
H	Update header/footer and add to 1.0 Scope description.	Feb. 21, 2008
I	Add temperature junction (T _j)...+175°C to 3.0 Absolute Max. Ratings.	April 4, 2008
J	Correct typo in Section 2 part numbers to be "R803" parts.	Sep. 5, 2008
K	Add application note on output capacitive load sensitivity when using low ESR capacitors.	Oct. 5, 2012
L	Correct typo on Theta JC/JA symbol	Oct. 15, 2012
M	Change Load Regulation limit for RC package for Sub Group 1	March 30, 2016

