



***Radiation Lot Acceptance Testing (RLAT) Radiation Testing of the RH117K
Positive Adjustable Regulator for Linear Technology***

Customer: Linear Technology, PO# 57481L

RAD Job Number: 10-435

Part Type Tested: RH117K Positive Adjustable Regulator.

Traceability Information/Lot Number/ Date Code: Lot Date Code: 1024A, Assembly Lot# 576815.1, FAB Lot# WP1058.1, Wafer 6. Information obtained from Linear Technology PO# 57481L. See photograph of unit under test in Appendix A.

Quantity of Units: 12 units received, 5-units for biased, 5-units for unbiased irradiation and 2 units for control. Serial numbers 57, 58, 59, 60 and 92 were biased during irradiation, serial numbers 93, 94, 95, 97 and 98 were unbiased during irradiation and serial numbers 99 and 100 were used as controls. See Appendix B for the radiation bias connection tables.

Radiation and Electrical Test Increments: 50-300rad(Si)/s ionizing radiation with electrical test increments: pre-irradiation, 20krad(Si), 50krad(Si), 100krad(Si), and 200krad(Si). Note that LINEAR TECHNOLOGY datasheet guarantees post-irradiation performance to only the 100krad(Si) dose level. Testing to 200krad(Si), as reported herein is an overtest of the datasheet guaranteed radiation performance specification

Pre-Irradiation Burn-In: None Specified

Overtest and Post-Irradiation Anneal: No overtest. No anneal.

Radiation Test Standard: MIL-STD 883 and/or MIL-STD-750 TM1019 (latest revision), Condition A.

Test Hardware and Software: LTS2020 Automated Tester, Entity ID TS04, Calibration Date: 04-28-10, Calibration Due 04-28-11. LTS2101 Family Board, Entity ID FB02. LTS0606 Test Fixture, Entity ID TF05. RH117 DUT Board. Test Program: RH117LT.SRC

Facility and Radiation Source: Radiation Assured Devices' Longmire Laboratories, Colorado Springs, CO. Gamma rays provided by JLSA 81-24 Co60 source. Dosimetry performed by CaF₂ TLDs traceable to NIST. RAD's dosimetry has been audited by DSCC and RAD has been awarded Laboratory Suitability for MIL-STD-750 and MIL-STD-883 TM 1019.

Irradiation and Test Temperature: Room temperature controlled to 24°C±6°C per MIL-STD-883 and MIL-STD-750.

RLAT Result: PASSED. The units showed no significant degradation with total dose. All parameters remained within their datasheet specifications to the maximum dose level tested of 200krad(Si)



1.0. Overview and Background

It is well known that total dose ionizing radiation can cause parametric degradation and ultimately functional failure in electronic devices. The damage occurs via electron-hole pair production, transport and trapping in the dielectric and interface regions. In discrete devices the bulk of the damage is frequently manifested as a reduction in the gain and/or breakdown voltage of the device. The damage will usually anneal with time following the end of the radiation exposure. Due to this annealing, and to ensure a worst-case test condition MIL-STD-883 TM1019.8 calls out a dose rate of 50 to 300rad(Si)/s as Condition A and further specifies that the time from the end of an incremental radiation exposure and electrical testing shall be 1-hour or less and the total time from the end of one incremental irradiation to the beginning of the next incremental radiation step should be 2-hours or less. The work described in this report was performed to meet MIL-STD-883 TM1019.8 Condition A.

2.0. Radiation Test Apparatus

The total ionizing dose testing described in this final report was performed using the facilities at Radiation Assured Devices' Longmire Laboratories in Colorado Springs, CO. The high dose rate total ionizing dose (TID) source is a JLSA 84-21 irradiator modified to provide a panoramic exposure. The Co-60 rods are held in the base of the irradiator heavily shielded by lead, during the radiation exposures the rod is raised by an electronic timer/controller and the exposure is performed in air. The dose rate for this irradiator in this configuration ranges from <1rad(Si)/s to a maximum of approximately 120rad(Si)/s, determined by the distance from the source. For high-dose rate experiments the bias boards are placed in a radial fashion equidistant from the raised Co-60 rods with the distance adjusted to provide the required dose rate. The irradiator calibration is maintained by Radiation Assured Devices Longmire Laboratories using thermoluminescent dosimeters (TLDs) traceable to the National Institute of Standards and Technology (NIST). Figure 2.1 shows a photograph of the JLSA 81-24 Co-60 irradiator at RAD's Longmire Laboratory facility.

RAD is currently certified by the Defense Supply Center Columbus (DSCC) for Laboratory Suitability under MIL STD 750. Additional details regarding Radiation Assured Devices dosimetry for TM1019 Condition A testing are available in RAD's report to DSCC entitled: "Dose Rate Mapping of the J.L. Shepherd and Associates Model 81 Irradiator Installed by Radiation Assured Devices"



Figure 2.1. Radiation Assured Devices' high dose rate Co-60 irradiator. The dose rate is obtained by positioning the device-under-test at a fixed distance from the gamma cell. The dose rate for this irradiator varies from approximately 120rad(Si)/s close to the rods down to 1rad(Si)/s at a distance of approximately 2-feet.



3.0. Radiation Test Conditions

The RH117K Positive Adjustable Regulator described in this final report was irradiated using a split $\pm 15V$ supply and with all pins tied to ground, that is biased and unbiased. See the TID Bias Tables in Appendix B for the full bias circuits. In our opinion, these bias circuits satisfy the requirements of MIL-STD-883H TM1019 Section 3.9.3 Bias and Loading Conditions which states “The bias applied to the test devices shall be selected to produce the greatest radiation induced damage or the worst-case damage for the intended application, if known. While maximum voltage is often worst case some bipolar linear device parameters (e.g. input bias current or maximum output load current) exhibit more degradation with 0 V bias.” Note that the determination of pass / fail for this lot is based on the response of the biased units only.

The devices were irradiated to a maximum total ionizing dose level of 200krad(Si) with incremental readings at 20krad(Si), 50krad(Si) and 100krad(Si). Electrical testing occurred within one hour following the end of each irradiation segment. For intermediate irradiations, the parts were tested and returned to total dose exposure within two hours from the end of the previous radiation increment.

The TID bias board was positioned in the Co-60 cell to provide the required minimum of 50rad(Si)/s and was located inside a lead-aluminum enclosure. The lead-aluminum enclosure is required under MIL-STD-883H TM1019.8 Section 3.4 that reads as follows: “Lead/Aluminum (Pb/Al) container. Test specimens shall be enclosed in a Pb/Al container to minimize dose enhancement effects caused by low-energy, scattered radiation. A minimum of 1.5 mm Pb, surrounding an inner shield of at least 0.7 mm Al, is required. This Pb/Al container produces an approximate charged particle equilibrium for Si and for TLDs such as CaF₂. The radiation field intensity shall be measured inside the Pb/Al container (1) initially, (2) when the source is changed, or (3) when the orientation or configuration of the source, container, or test-fixture is changed. This measurement shall be performed by placing a dosimeter (e.g., a TLD) in the device-irradiation container at the approximate test-device position. If it can be demonstrated that low energy scattered radiation is small enough that it will not cause dosimetry errors due to dose enhancement, the Pb/Al container may be omitted”.

The final dose rate within the high dose rate lead-aluminum enclosure was determined based on TLD dosimetry measurements (see previous section). The final dose rate for this work was 69.8rad(Si)/s with a precision of $\pm 5\%$.



4.0. Tested Parameters

During the radiation lot acceptance testing the following pre- and post-irradiation electrical parameters were measured:

1. Reference Voltage, $V_{DIFF}=V_{IN}-V_{OUT}=3V$, $I_L=10mA$
2. Reference Voltage, $V_{DIFF}=40V$, $I_L=10mA$
3. Reference Voltage, $V_{DIFF}=3V$, $I_L=1.5A$
4. Reference Voltage, $V_{DIFF}=40V$, $I_L=0.3A$
5. Line Regulation, $V_{DIFF}=3V$ to $40V$, $I_L=10mA$
6. Load Regulation, $V_{OUT}\leq 5V$ $V_{DIFF}=5V$, $V_{IN}=6.25V$, $I_L=10mA$ to $1.5A$
7. Load Regulation, $V_{OUT}\geq 5V$ $V_{DIFF}=5V$, $V_{IN}=11.25V$, $I_L=10mA$ to $1.5A$
8. Adjust Pin Current, $V_{DIFF}=2.5V$, $I_L=10mA$
9. Adjust Pin Current, $V_{DIFF}=5V$, $I_L=10mA$
10. Adjust Pin Current, $V_{DIFF}=40V$, $I_L=10mA$
11. Adjust Pin Current Change, $V_{DIFF}=5V$, $I_L=10mA$ to $1.5A$
12. Adjust Pin Current Change, $V_{DIFF}=2.5V$ to $40V$, $I_L=10mA$
13. Minimum Load Current, $V_{DIFF}=40V$
14. Current Limit $V_{DIFF}\leq 15V$, $V_{DIFF}=15V$
15. Current Limit $V_{DIFF}=40V$, $V_{DIFF}=40V$

The parametric data was obtained as “read and record” and all the raw data plus an attributes summary are contained in this report as well as in a separate Excel file. The attributes data contains the average, standard deviation and the average with the KTL values applied. The KTL values used is 2.742 per MIL HDBK 814 using one sided tolerance limits of 90/90 and a 5-piece sample size. This survival probability/level of confidence is consistent with a 22-piece sample size and zero failures analyzed using a lot tolerance percent defective (LTPD) approach. Note that the following criteria must be met for a device to pass the low dose rate test: following the radiation exposure each of the 5 pieces irradiated under electrical bias shall pass the specification value. The units irradiated without electrical bias and the KTL statistics are included in this report for reference only. If any of the 5 pieces irradiated under electrical bias exceed the datasheet specifications, then the lot could be logged as a failure.



5.0. Total Ionizing Dose Test Results

Using the conditions stated above, the RH117K-Positive Adjustable Regulator (from the lot date code identified on the first page of this test report) passed the enhanced low dose rate sensitivity test to 200krad(Si) with all parameters remaining within their pre- and/or post-radiation specification limits. As noted above (Section 4) the data for the units-under-test irradiated in the unbiased condition and the KTL statistics presented in this report are for reference only and are not used for the determination of “PASS/FAIL” for the lot. Note that the KTLs statistics are “out of specification” for several parameters (including V_{REF1} through V_{REF4} and the Current Limit ($V_{OUT}=15V$)). This “out of specification” is due to the precision of the measurements and is not reflective of any radiation-induced degradation. We have upgraded the test program to include auto-ranging for future tests and should see an improvement in the overall precision of the test data.

Figures 5.1 through 5.15 show plots of all the measured parameters versus total ionizing dose while Tables 5.1 – 5.15 show the corresponding raw data for each of these parameters. In these data plots the solid diamonds are the average of the measured data points for the sample irradiated under electrical bias while the shaded diamonds are the average of the measured data points for the units irradiated with all pins tied to ground. The black lines (solid or dashed) are the average of the data points after application of the KTL statistics on the sample irradiated in the biased condition while the shaded lines (solid or dashed) are the average of the data points after application of the KTL statistics on the sample irradiated in the unbiased condition. The red dotted line(s) are the pre- and/or post-irradiation minimum and/or maximum specification value as defined in the datasheet and/or test plan.

The control units, as expected, show no significant changes to any of the parameters. Therefore we can conclude that the electrical testing remained in control throughout the duration of the tests and the observed degradation was due to the radiation exposure. Note that Appendix D lists all of the figures and tables used in this section.

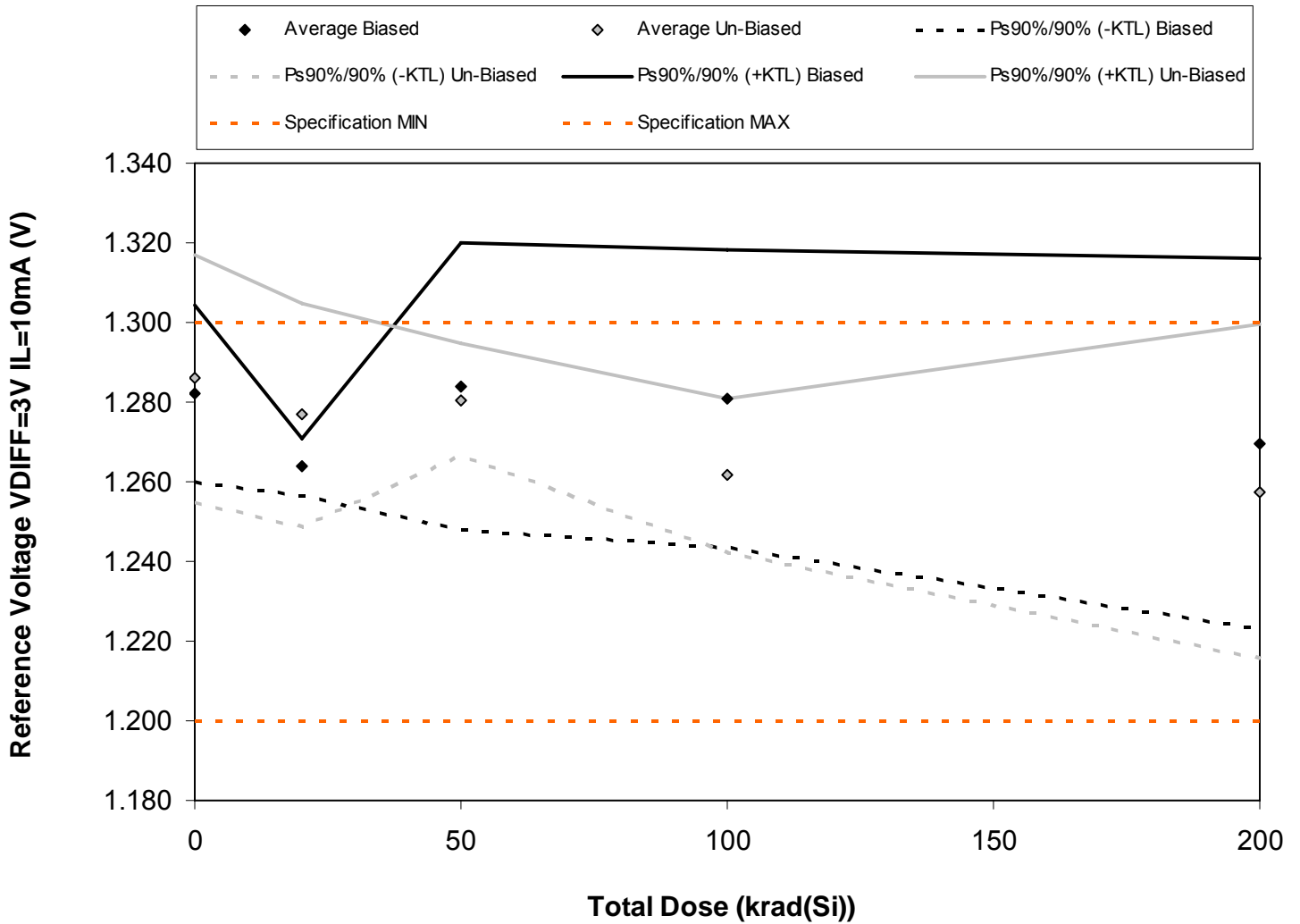

Figure 5.1. Plot of Reference Voltage VDIFF=3V IL=10mA (V) versus total dose. The solid diamonds are the average of the measured data points for the samples irradiated under electrical bias while the shaded diamonds are the average of the measured data points for the samples irradiated with all pins tied to ground. The black lines (solid and/or dashed) are the average of the data points after application of the KTL statistics on the samples irradiated under electrical bias while the gray lines (solid and/or dashed) are the average of the data points after application of the KTL statistics on the samples irradiated in the unbiased condition. The red dotted line(s) are the pre- and/or post-irradiation minimum and/or maximum specification value as defined in the datasheet and/or test plan.



Table 5.1. Raw data for Reference Voltage VDIFF=3V IL=10mA (V) versus total dose, including the statistical analysis, specification and the status of the testing (pass/fail).

| Reference Voltage VDIFF=3V IL=10mA (V) | Total Dose (krad(Si)) | | | | |
|--|-----------------------|--------------|--------------|--------------|--------------|
| | 0 | 20 | 50 | 100 | 200 |
| Device | 0 | 20 | 50 | 100 | 200 |
| 57 | 1.290 | 1.263 | 1.291 | 1.284 | 1.289 |
| 58 | 1.286 | 1.261 | 1.263 | 1.285 | 1.274 |
| 59 | 1.273 | 1.264 | 1.288 | 1.299 | 1.253 |
| 60 | 1.288 | 1.263 | 1.280 | 1.262 | 1.251 |
| 92 | 1.274 | 1.268 | 1.297 | 1.275 | 1.281 |
| 93 | 1.299 | 1.266 | 1.288 | 1.261 | 1.249 |
| 94 | 1.274 | 1.287 | 1.284 | 1.266 | 1.253 |
| 95 | 1.296 | 1.285 | 1.277 | 1.256 | 1.240 |
| 97 | 1.276 | 1.266 | 1.278 | 1.254 | 1.268 |
| 98 | 1.285 | 1.280 | 1.276 | 1.271 | 1.278 |
| 99 | 1.277 | 1.290 | 1.287 | 1.291 | 1.267 |
| 100 | 1.270 | 1.271 | 1.286 | 1.281 | 1.288 |
| Biased Statistics | | | | | |
| Average Biased | 1.282 | 1.264 | 1.284 | 1.281 | 1.270 |
| Std Dev Biased | 0.008 | 0.003 | 0.013 | 0.014 | 0.017 |
| Ps90%/90% (+KTL) Biased | 1.304 | 1.271 | 1.320 | 1.318 | 1.316 |
| Ps90%/90% (-KTL) Biased | 1.260 | 1.257 | 1.248 | 1.244 | 1.223 |
| Un-Biased Statistics | | | | | |
| Average Un-Biased | 1.286 | 1.277 | 1.281 | 1.262 | 1.258 |
| Std Dev Un-Biased | 0.011 | 0.010 | 0.005 | 0.007 | 0.015 |
| Ps90%/90% (+KTL) Un-Biased | 1.317 | 1.305 | 1.295 | 1.281 | 1.299 |
| Ps90%/90% (-KTL) Un-Biased | 1.255 | 1.249 | 1.266 | 1.242 | 1.216 |
| Specification MIN | 1.200 | 1.200 | 1.200 | 1.200 | 1.200 |
| Status | PASS | PASS | PASS | PASS | PASS |
| Specification MAX | 1.300 | 1.300 | 1.300 | 1.300 | 1.300 |
| Status | PASS | PASS | PASS | PASS | PASS |

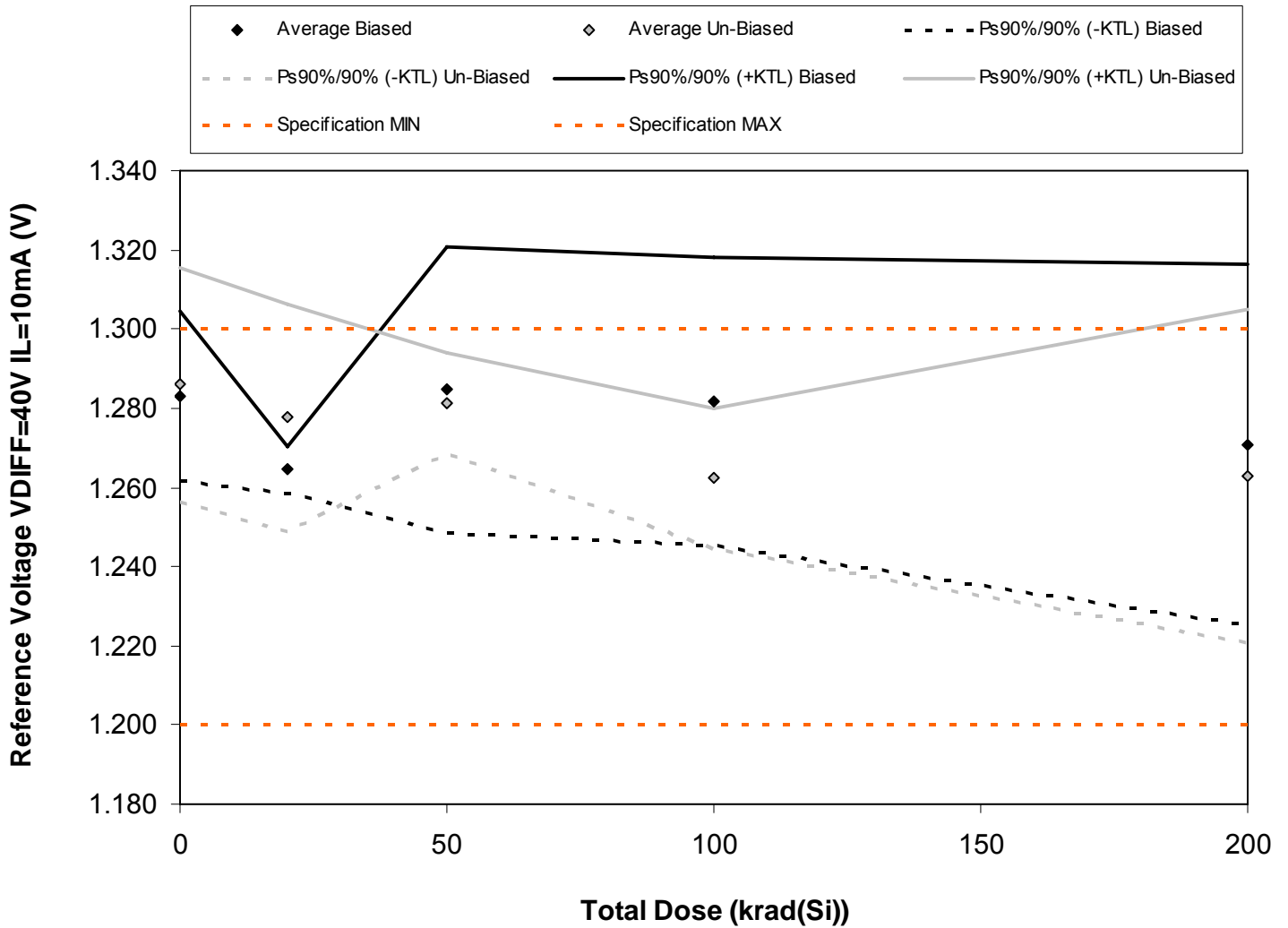

Figure 5.2. Plot of Reference Voltage VDIFF=40V IL=10mA (V) versus total dose. The solid diamonds are the average of the measured data points for the samples irradiated under electrical bias while the shaded diamonds are the average of the measured data points for the samples irradiated with all pins tied to ground. The black lines (solid and/or dashed) are the average of the data points after application of the KTL statistics on the samples irradiated under electrical bias while the gray lines (solid and/or dashed) are the average of the data points after application of the KTL statistics on the samples irradiated in the unbiased condition. The red dotted line(s) are the pre- and/or post-irradiation minimum and/or maximum specification value as defined in the datasheet and/or test plan.



Table 5.2. Raw data for Reference Voltage VDIFF=40V IL=10mA (V) versus total dose, including the statistical analysis, specification and the status of the testing (pass/fail).

| Reference Voltage VDIFF=40V IL=10mA (V) | Total Dose (krad(Si)) | | | | |
|---|-----------------------|--------------|--------------|--------------|--------------|
| | 0 | 20 | 50 | 100 | 200 |
| Device | | | | | |
| 57 | 1.290 | 1.264 | 1.292 | 1.285 | 1.290 |
| 58 | 1.287 | 1.262 | 1.264 | 1.285 | 1.274 |
| 59 | 1.274 | 1.264 | 1.289 | 1.299 | 1.254 |
| 60 | 1.289 | 1.264 | 1.280 | 1.263 | 1.253 |
| 92 | 1.275 | 1.268 | 1.298 | 1.276 | 1.282 |
| 93 | 1.297 | 1.266 | 1.288 | 1.262 | 1.255 |
| 94 | 1.275 | 1.288 | 1.284 | 1.266 | 1.257 |
| 95 | 1.297 | 1.286 | 1.278 | 1.257 | 1.246 |
| 97 | 1.276 | 1.267 | 1.279 | 1.255 | 1.271 |
| 98 | 1.285 | 1.281 | 1.277 | 1.271 | 1.285 |
| 99 | 1.277 | 1.291 | 1.288 | 1.292 | 1.268 |
| 100 | 1.271 | 1.271 | 1.287 | 1.281 | 1.288 |
| Biased Statistics | | | | | |
| Average Biased | 1.283 | 1.264 | 1.285 | 1.282 | 1.271 |
| Std Dev Biased | 0.008 | 0.002 | 0.013 | 0.013 | 0.017 |
| Ps90%/90% (+KTL) Biased | 1.305 | 1.270 | 1.321 | 1.318 | 1.316 |
| Ps90%/90% (-KTL) Biased | 1.261 | 1.258 | 1.248 | 1.245 | 1.225 |
| Un-Biased Statistics | | | | | |
| Average Un-Biased | 1.286 | 1.278 | 1.281 | 1.262 | 1.263 |
| Std Dev Un-Biased | 0.011 | 0.010 | 0.005 | 0.007 | 0.015 |
| Ps90%/90% (+KTL) Un-Biased | 1.316 | 1.306 | 1.294 | 1.280 | 1.305 |
| Ps90%/90% (-KTL) Un-Biased | 1.256 | 1.249 | 1.268 | 1.244 | 1.221 |
| Specification MIN | 1.200 | 1.200 | 1.200 | 1.200 | 1.200 |
| Status | PASS | PASS | PASS | PASS | PASS |
| Specification MAX | 1.300 | 1.300 | 1.300 | 1.300 | 1.300 |
| Status | PASS | PASS | PASS | PASS | PASS |

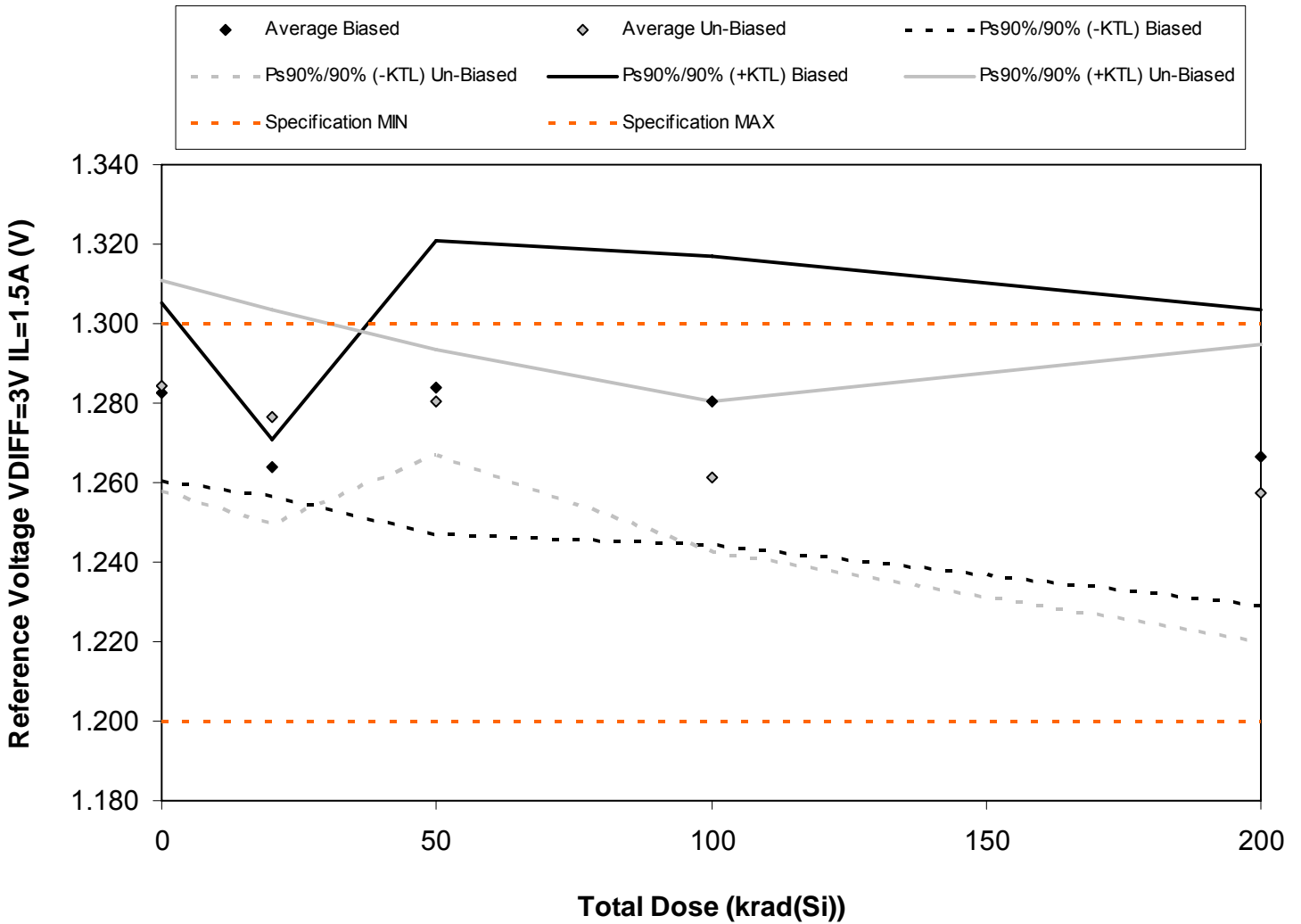

Figure 5.3. Plot of Reference Voltage $V_{DIFF}=3V$ $I_L=1.5A$ (V) versus total dose. The solid diamonds are the average of the measured data points for the samples irradiated under electrical bias while the shaded diamonds are the average of the measured data points for the samples irradiated with all pins tied to ground. The black lines (solid and/or dashed) are the average of the data points after application of the KTL statistics on the samples irradiated under electrical bias while the gray lines (solid and/or dashed) are the average of the data points after application of the KTL statistics on the samples irradiated in the unbiased condition. The red dotted line(s) are the pre- and/or post-irradiation minimum and/or maximum specification value as defined in the datasheet and/or test plan.



Table 5.3. Raw data for Reference Voltage VDIFF=3V IL=1.5A (V) versus total dose, including the statistical analysis, specification and the status of the testing (pass/fail).

| Reference Voltage VDIFF=3V IL=1.5A (V) | Total Dose (krad(Si)) | | | | |
|--|-----------------------|--------------|--------------|--------------|--------------|
| | 0 | 20 | 50 | 100 | 200 |
| Device | 0 | 20 | 50 | 100 | 200 |
| 57 | 1.290 | 1.263 | 1.292 | 1.284 | 1.277 |
| 58 | 1.286 | 1.261 | 1.263 | 1.284 | 1.271 |
| 59 | 1.274 | 1.264 | 1.289 | 1.298 | 1.253 |
| 60 | 1.290 | 1.263 | 1.279 | 1.262 | 1.251 |
| 92 | 1.274 | 1.268 | 1.297 | 1.275 | 1.280 |
| 93 | 1.292 | 1.266 | 1.287 | 1.261 | 1.250 |
| 94 | 1.274 | 1.287 | 1.284 | 1.265 | 1.253 |
| 95 | 1.296 | 1.283 | 1.277 | 1.256 | 1.241 |
| 97 | 1.276 | 1.266 | 1.278 | 1.254 | 1.267 |
| 98 | 1.284 | 1.280 | 1.276 | 1.271 | 1.275 |
| 99 | 1.277 | 1.290 | 1.287 | 1.289 | 1.266 |
| 100 | 1.270 | 1.271 | 1.286 | 1.281 | 1.286 |
| Biased Statistics | | | | | |
| Average Biased | 1.283 | 1.264 | 1.284 | 1.281 | 1.266 |
| Std Dev Biased | 0.008 | 0.003 | 0.013 | 0.013 | 0.014 |
| Ps90%/90% (+KTL) Biased | 1.305 | 1.271 | 1.321 | 1.317 | 1.304 |
| Ps90%/90% (-KTL) Biased | 1.260 | 1.257 | 1.247 | 1.244 | 1.229 |
| Un-Biased Statistics | | | | | |
| Average Un-Biased | 1.284 | 1.276 | 1.280 | 1.261 | 1.257 |
| Std Dev Un-Biased | 0.010 | 0.010 | 0.005 | 0.007 | 0.014 |
| Ps90%/90% (+KTL) Un-Biased | 1.311 | 1.303 | 1.294 | 1.280 | 1.295 |
| Ps90%/90% (-KTL) Un-Biased | 1.258 | 1.249 | 1.267 | 1.243 | 1.220 |
| Specification MIN | 1.200 | 1.200 | 1.200 | 1.200 | 1.200 |
| Status | PASS | PASS | PASS | PASS | PASS |
| Specification MAX | 1.300 | 1.300 | 1.300 | 1.300 | 1.300 |
| Status | PASS | PASS | PASS | PASS | PASS |

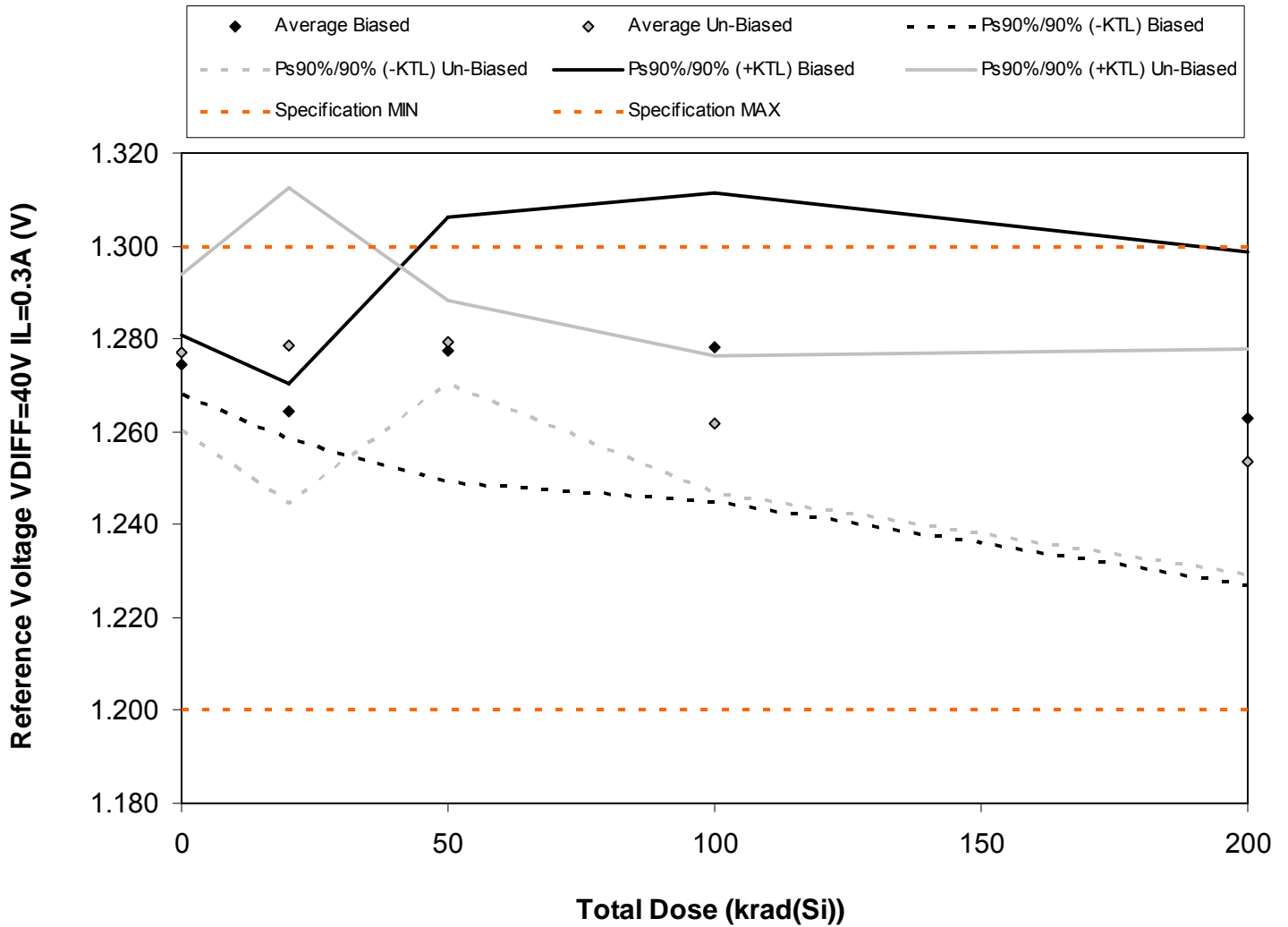

Figure 5.4. Plot of Reference Voltage $V_{DIFF}=40V$ $I_L=0.3A$ (V) versus total dose. The solid diamonds are the average of the measured data points for the samples irradiated under electrical bias while the shaded diamonds are the average of the measured data points for the samples irradiated with all pins tied to ground. The black lines (solid and/or dashed) are the average of the data points after application of the KTL statistics on the samples irradiated under electrical bias while the gray lines (solid and/or dashed) are the average of the data points after application of the KTL statistics on the samples irradiated in the unbiased condition. The red dotted line(s) are the pre- and/or post-irradiation minimum and/or maximum specification value as defined in the datasheet and/or test plan.



Table 5.4. Raw data for Reference Voltage VDIFF=40V IL=0.3A (V) versus total dose, including the statistical analysis, specification and the status of the testing (pass/fail).

| Reference Voltage VDIFF=40V IL=0.3A (V) | Total Dose (krad(Si)) | | | | |
|---|-----------------------|--------------|--------------|--------------|--------------|
| | 0 | 20 | 50 | 100 | 200 |
| Device | | | | | |
| 57 | 1.274 | 1.264 | 1.292 | 1.280 | 1.254 |
| 58 | 1.277 | 1.262 | 1.263 | 1.285 | 1.271 |
| 59 | 1.272 | 1.264 | 1.277 | 1.292 | 1.254 |
| 60 | 1.277 | 1.264 | 1.280 | 1.260 | 1.253 |
| 92 | 1.273 | 1.268 | 1.276 | 1.274 | 1.282 |
| 93 | 1.273 | 1.266 | 1.281 | 1.263 | 1.250 |
| 94 | 1.274 | 1.286 | 1.284 | 1.266 | 1.253 |
| 95 | 1.282 | 1.294 | 1.278 | 1.257 | 1.244 |
| 97 | 1.271 | 1.266 | 1.277 | 1.255 | 1.253 |
| 98 | 1.285 | 1.281 | 1.276 | 1.267 | 1.268 |
| 99 | 1.277 | 1.275 | 1.283 | 1.273 | 1.268 |
| 100 | 1.269 | 1.271 | 1.287 | 1.269 | 1.276 |
| Biased Statistics | | | | | |
| Average Biased | 1.275 | 1.264 | 1.278 | 1.278 | 1.263 |
| Std Dev Biased | 0.002 | 0.002 | 0.010 | 0.012 | 0.013 |
| Ps90%/90% (+KTL) Biased | 1.281 | 1.270 | 1.306 | 1.311 | 1.299 |
| Ps90%/90% (-KTL) Biased | 1.268 | 1.258 | 1.249 | 1.245 | 1.227 |
| Un-Biased Statistics | | | | | |
| Average Un-Biased | 1.277 | 1.279 | 1.279 | 1.262 | 1.254 |
| Std Dev Un-Biased | 0.006 | 0.012 | 0.003 | 0.005 | 0.009 |
| Ps90%/90% (+KTL) Un-Biased | 1.294 | 1.313 | 1.288 | 1.276 | 1.278 |
| Ps90%/90% (-KTL) Un-Biased | 1.260 | 1.245 | 1.270 | 1.247 | 1.229 |
| Specification MIN | 1.200 | 1.200 | 1.200 | 1.200 | 1.200 |
| Status | PASS | PASS | PASS | PASS | PASS |
| Specification MAX | 1.300 | 1.300 | 1.300 | 1.300 | 1.300 |
| Status | PASS | PASS | PASS | PASS | PASS |

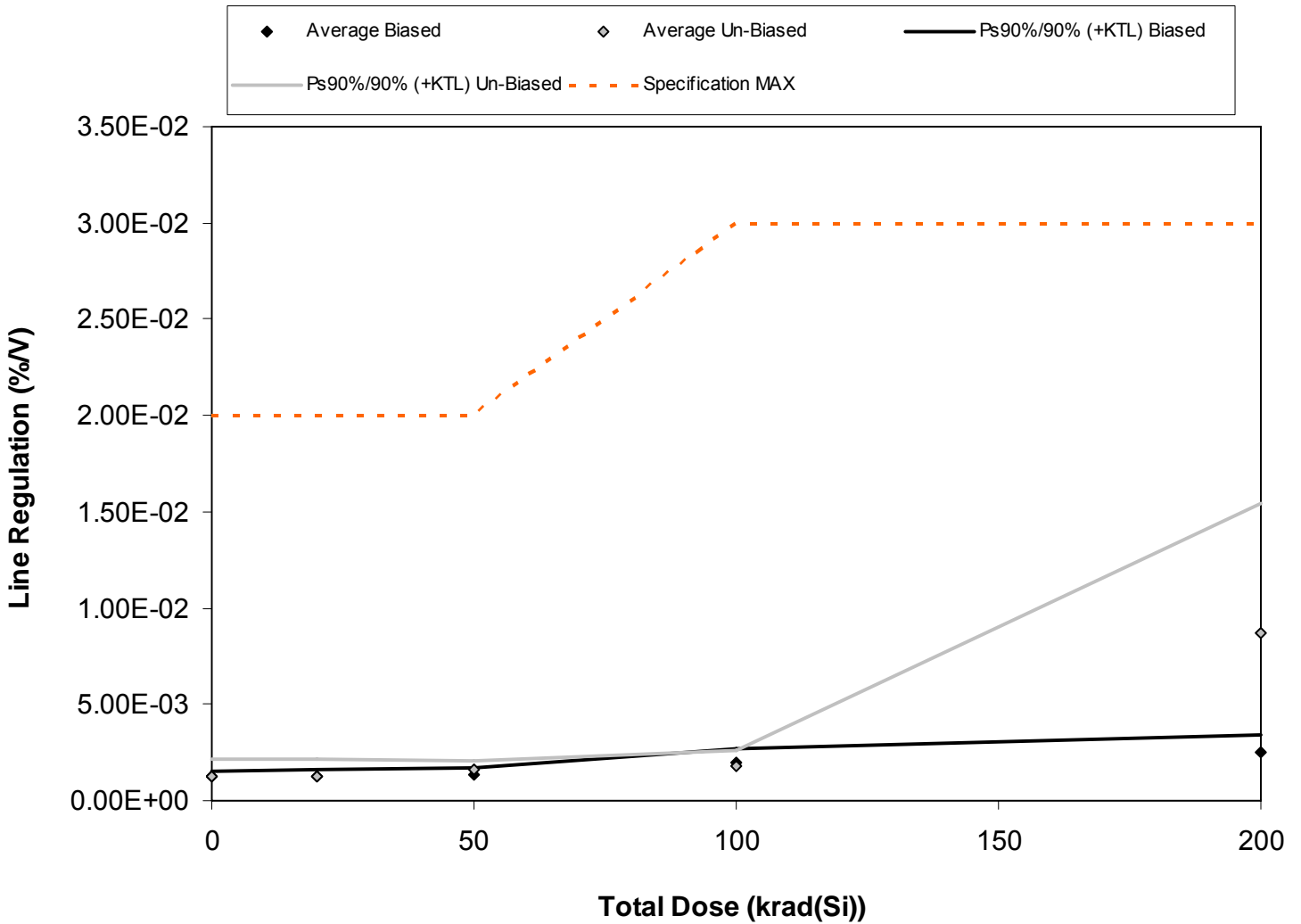

Figure 5.5. Plot of Line Regulation (%/V) versus total dose. The solid diamonds are the average of the measured data points for the samples irradiated under electrical bias while the shaded diamonds are the average of the measured data points for the samples irradiated with all pins tied to ground. The black lines (solid and/or dashed) are the average of the data points after application of the KTL statistics on the samples irradiated under electrical bias while the gray lines (solid and/or dashed) are the average of the data points after application of the KTL statistics on the samples irradiated in the unbiased condition. The red dotted line(s) are the pre- and/or post-irradiation minimum and/or maximum specification value as defined in the datasheet and/or test plan.



Table 5.5. Raw data for Line Regulation (%/V) versus total dose, including the statistical analysis, specification and the status of the testing (pass/fail).

| Line Regulation (%/V) | Total Dose (krad(Si)) | | | | |
|-----------------------------|-----------------------|-----------------|-----------------|-----------------|-----------------|
| Device | 0 | 20 | 50 | 100 | 200 |
| 57 | 1.30E-03 | 1.20E-03 | 1.30E-03 | 1.60E-03 | 2.30E-03 |
| 58 | 1.10E-03 | 1.30E-03 | 1.50E-03 | 2.00E-03 | 2.00E-03 |
| 59 | 1.10E-03 | 1.10E-03 | 1.20E-03 | 2.10E-03 | 2.50E-03 |
| 60 | 1.30E-03 | 1.40E-03 | 1.50E-03 | 2.30E-03 | 2.90E-03 |
| 92 | 1.30E-03 | 1.10E-03 | 1.40E-03 | 1.90E-03 | 2.70E-03 |
| 93 | 9.00E-04 | 1.80E-03 | 1.60E-03 | 1.90E-03 | 1.03E-02 |
| 94 | 1.40E-03 | 1.10E-03 | 1.70E-03 | 1.70E-03 | 7.10E-03 |
| 95 | 1.50E-03 | 9.00E-04 | 1.80E-03 | 2.20E-03 | 1.08E-02 |
| 97 | 1.60E-03 | 1.30E-03 | 1.40E-03 | 1.50E-03 | 5.10E-03 |
| 98 | 1.00E-03 | 1.30E-03 | 1.40E-03 | 1.50E-03 | 1.01E-02 |
| 99 | 1.60E-03 | 1.50E-03 | 1.40E-03 | 1.20E-03 | 1.60E-03 |
| 100 | 1.00E-03 | 7.00E-04 | 1.30E-03 | 1.20E-03 | 9.00E-04 |
| Biased Statistics | | | | | |
| Average Biased | 1.22E-03 | 1.22E-03 | 1.38E-03 | 1.98E-03 | 2.48E-03 |
| Std Dev Biased | 1.10E-04 | 1.30E-04 | 1.30E-04 | 2.59E-04 | 3.49E-04 |
| Ps90%/90% (+KTL) Biased | 1.52E-03 | 1.58E-03 | 1.74E-03 | 2.69E-03 | 3.44E-03 |
| Ps90%/90% (-KTL) Biased | 9.20E-04 | 8.62E-04 | 1.02E-03 | 1.27E-03 | 1.52E-03 |
| Un-Biased Statistics | | | | | |
| Average Un-Biased | 1.28E-03 | 1.28E-03 | 1.58E-03 | 1.76E-03 | 8.68E-03 |
| Std Dev Un-Biased | 3.11E-04 | 3.35E-04 | 1.79E-04 | 2.97E-04 | 2.47E-03 |
| Ps90%/90% (+KTL) Un-Biased | 2.13E-03 | 2.20E-03 | 2.07E-03 | 2.57E-03 | 1.55E-02 |
| Ps90%/90% (-KTL) Un-Biased | 4.26E-04 | 3.62E-04 | 1.09E-03 | 9.47E-04 | 1.90E-03 |
| Specification MAX | 2.00E-02 | 2.00E-02 | 2.00E-02 | 3.00E-02 | 3.00E-02 |
| Status | PASS | PASS | PASS | PASS | PASS |

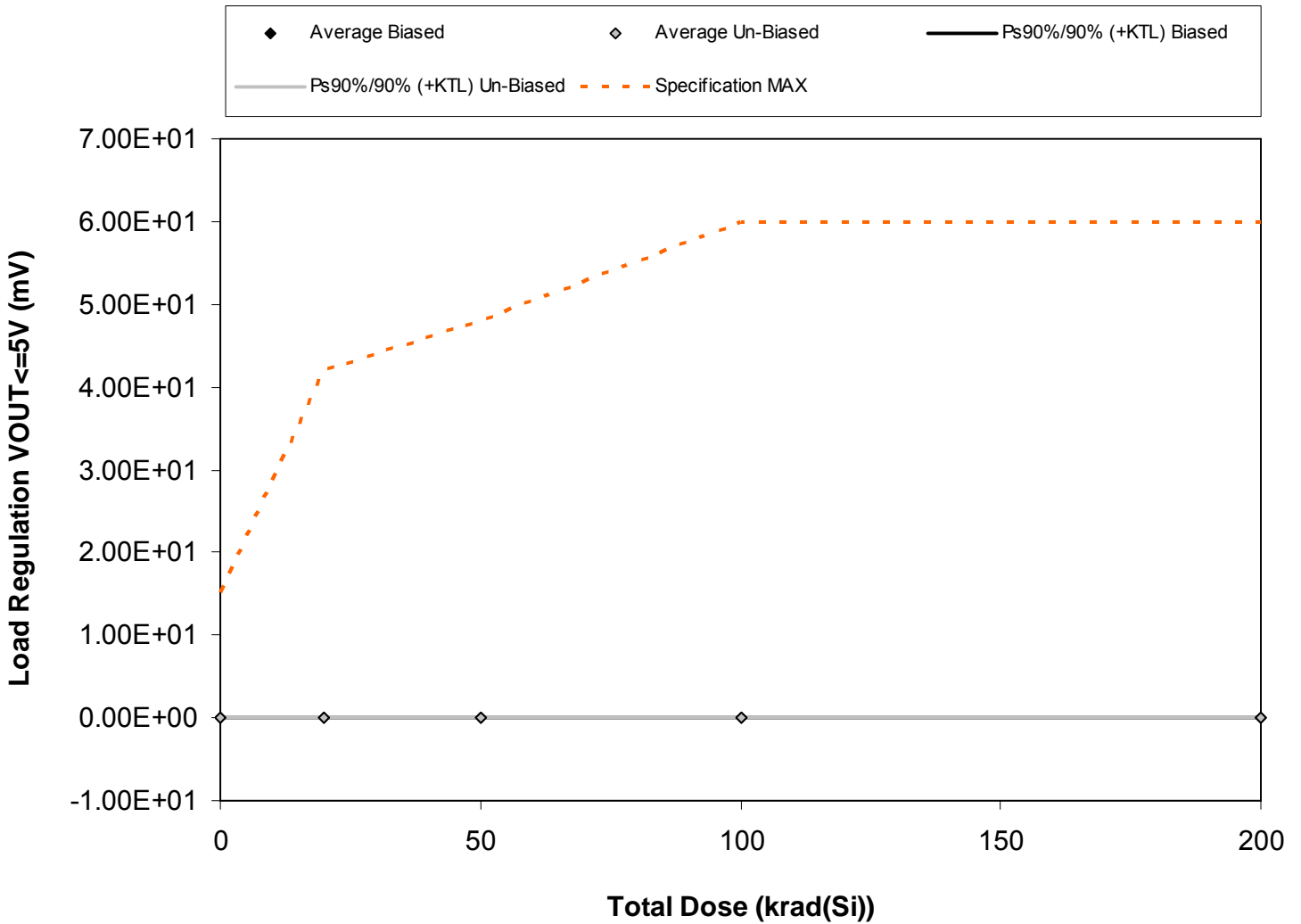

Figure 5.6. Plot of Load Regulation VOUT<=5V (mV) versus total dose. The solid diamonds are the average of the measured data points for the samples irradiated under electrical bias while the shaded diamonds are the average of the measured data points for the samples irradiated with all pins tied to ground. The black lines (solid and/or dashed) are the average of the data points after application of the KTL statistics on the samples irradiated under electrical bias while the gray lines (solid and/or dashed) are the average of the data points after application of the KTL statistics on the samples irradiated in the unbiased condition. The red dotted line(s) are the pre- and/or post-irradiation minimum and/or maximum specification value as defined in the datasheet and/or test plan.



Table 5.6. Raw data for Load Regulation $V_{OUT} \leq 5V$ (mV) versus total dose, including the statistical analysis, specification and the status of the testing (pass/fail).

| Load Regulation $V_{OUT} \leq 5V$ (mV) | Total Dose (krad(Si)) | | | | |
|--|-----------------------|-----------------|-----------------|-----------------|-----------------|
| | 0 | 20 | 50 | 100 | 200 |
| Device | | | | | |
| 57 | 3.87E-04 | 2.02E-04 | -8.40E-05 | 1.68E-04 | 3.40E-05 |
| 58 | 8.40E-05 | 0.00E+00 | 8.40E-05 | -1.70E-05 | 2.53E-04 |
| 59 | 6.70E-05 | 3.03E-04 | 6.57E-04 | 5.10E-05 | 1.52E-04 |
| 60 | 2.36E-04 | -3.40E-05 | 8.40E-05 | -8.40E-05 | 3.87E-04 |
| 92 | 2.86E-04 | 1.70E-05 | 1.52E-04 | -1.01E-04 | 2.53E-04 |
| 93 | 6.06E-04 | -6.70E-05 | -2.02E-04 | 2.02E-04 | -3.20E-04 |
| 94 | -1.70E-05 | 1.68E-04 | 0.00E+00 | -1.18E-04 | -2.36E-04 |
| 95 | 0.00E+00 | 3.81E-03 | 1.18E-04 | -1.18E-04 | -5.05E-04 |
| 97 | -2.02E-04 | -1.70E-05 | -1.70E-05 | -5.10E-05 | 1.18E-04 |
| 98 | 4.88E-04 | 2.36E-04 | 3.70E-04 | -3.40E-05 | 0.00E+00 |
| 99 | 3.40E-05 | 6.70E-05 | 4.04E-04 | 0.00E+00 | 0.00E+00 |
| 100 | -6.70E-05 | -2.19E-04 | -2.36E-04 | 5.10E-05 | 4.38E-04 |
| Biased Statistics | | | | | |
| Average Biased | 2.12E-04 | 9.76E-05 | 1.79E-04 | 3.40E-06 | 2.16E-04 |
| Std Dev Biased | 1.36E-04 | 1.47E-04 | 2.81E-04 | 1.10E-04 | 1.32E-04 |
| Ps90%/90% (+KTL) Biased | 5.85E-04 | 5.01E-04 | 9.50E-04 | 3.05E-04 | 5.76E-04 |
| Ps90%/90% (-KTL) Biased | -1.61E-04 | -3.05E-04 | -5.93E-04 | -2.98E-04 | -1.45E-04 |
| Un-Biased Statistics | | | | | |
| Average Un-Biased | 1.75E-04 | 8.25E-04 | 5.38E-05 | -2.38E-05 | -1.89E-04 |
| Std Dev Un-Biased | 3.51E-04 | 1.67E-03 | 2.11E-04 | 1.32E-04 | 2.50E-04 |
| Ps90%/90% (+KTL) Un-Biased | 1.14E-03 | 5.41E-03 | 6.31E-04 | 3.38E-04 | 4.96E-04 |
| Ps90%/90% (-KTL) Un-Biased | -7.88E-04 | -3.76E-03 | -5.24E-04 | -3.85E-04 | -8.73E-04 |
| Specification MAX | 1.50E+01 | 4.20E+01 | 4.80E+01 | 6.00E+01 | 6.00E+01 |
| Status | PASS | PASS | PASS | PASS | PASS |

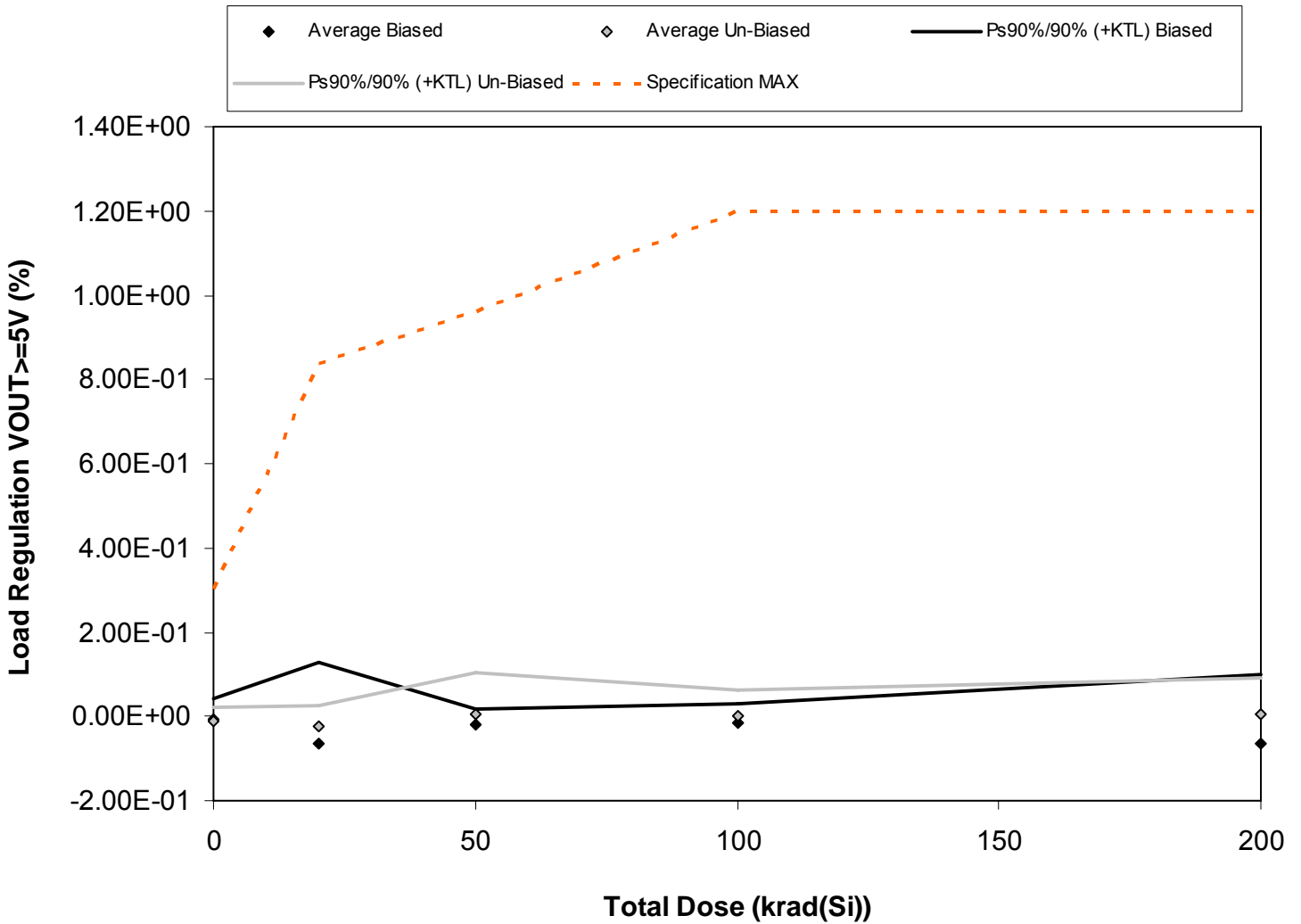

Figure 5.7. Plot of Load Regulation VOUT >= 5V (%) versus total dose. The solid diamonds are the average of the measured data points for the samples irradiated under electrical bias while the shaded diamonds are the average of the measured data points for the samples irradiated with all pins tied to ground. The black lines (solid and/or dashed) are the average of the data points after application of the KTL statistics on the samples irradiated under electrical bias while the gray lines (solid and/or dashed) are the average of the data points after application of the KTL statistics on the samples irradiated in the unbiased condition. The red dotted line(s) are the pre- and/or post-irradiation minimum and/or maximum specification value as defined in the datasheet and/or test plan.



Table 5.7. Raw data for Load Regulation $V_{OUT} \geq 5V$ (%) versus total dose, including the statistical analysis, specification and the status of the testing (pass/fail).

| Load Regulation $V_{OUT} \geq 5V$ (%) | Total Dose (krad(Si)) | | | | |
|---------------------------------------|-----------------------|-----------------|-----------------|-----------------|-----------------|
| | 0 | 20 | 50 | 100 | 200 |
| Device | | | | | |
| 57 | -4.10E-02 | -8.00E-02 | -3.90E-02 | -2.40E-02 | -1.59E-01 |
| 58 | -1.20E-02 | -7.60E-02 | -2.40E-02 | 1.10E-02 | -1.60E-02 |
| 59 | -5.00E-03 | 1.90E-02 | -2.00E-02 | -1.40E-02 | -7.90E-02 |
| 60 | 8.00E-03 | -1.30E-02 | -2.00E-03 | -2.30E-02 | -7.00E-02 |
| 92 | 4.00E-03 | -1.63E-01 | -1.50E-02 | -3.40E-02 | -9.00E-03 |
| 93 | -4.00E-03 | -7.00E-03 | -1.80E-02 | 3.40E-02 | 3.50E-02 |
| 94 | -1.00E-03 | -2.80E-02 | 6.70E-02 | 0.00E+00 | 4.00E-02 |
| 95 | -3.00E-03 | -1.00E-03 | -6.00E-03 | 8.00E-03 | -1.50E-02 |
| 97 | -2.90E-02 | -4.00E-02 | -2.10E-02 | -1.70E-02 | -3.20E-02 |
| 98 | -1.30E-02 | -3.70E-02 | 5.00E-03 | -2.20E-02 | -5.00E-03 |
| 99 | 1.20E-02 | -7.00E-03 | -1.90E-02 | 2.00E-03 | 2.30E-02 |
| 100 | 1.70E-02 | 8.00E-03 | -3.50E-02 | 1.30E-02 | 0.00E+00 |
| Biased Statistics | | | | | |
| Average Biased | -9.20E-03 | -6.26E-02 | -2.00E-02 | -1.68E-02 | -6.66E-02 |
| Std Dev Biased | 1.94E-02 | 7.01E-02 | 1.35E-02 | 1.71E-02 | 6.04E-02 |
| Ps90%/90% (+KTL) Biased | 4.40E-02 | 1.30E-01 | 1.69E-02 | 3.00E-02 | 9.90E-02 |
| Ps90%/90% (-KTL) Biased | -6.24E-02 | -2.55E-01 | -5.69E-02 | -6.36E-02 | -2.32E-01 |
| Un-Biased Statistics | | | | | |
| Average Un-Biased | -1.00E-02 | -2.26E-02 | 5.40E-03 | 6.00E-04 | 4.60E-03 |
| Std Dev Un-Biased | 1.16E-02 | 1.77E-02 | 3.59E-02 | 2.23E-02 | 3.16E-02 |
| Ps90%/90% (+KTL) Un-Biased | 2.17E-02 | 2.59E-02 | 1.04E-01 | 6.18E-02 | 9.12E-02 |
| Ps90%/90% (-KTL) Un-Biased | -4.17E-02 | -7.11E-02 | -9.32E-02 | -6.06E-02 | -8.20E-02 |
| Specification MAX | 3.00E-01 | 8.40E-01 | 9.60E-01 | 1.20E+00 | 1.20E+00 |
| Status | PASS | PASS | PASS | PASS | PASS |

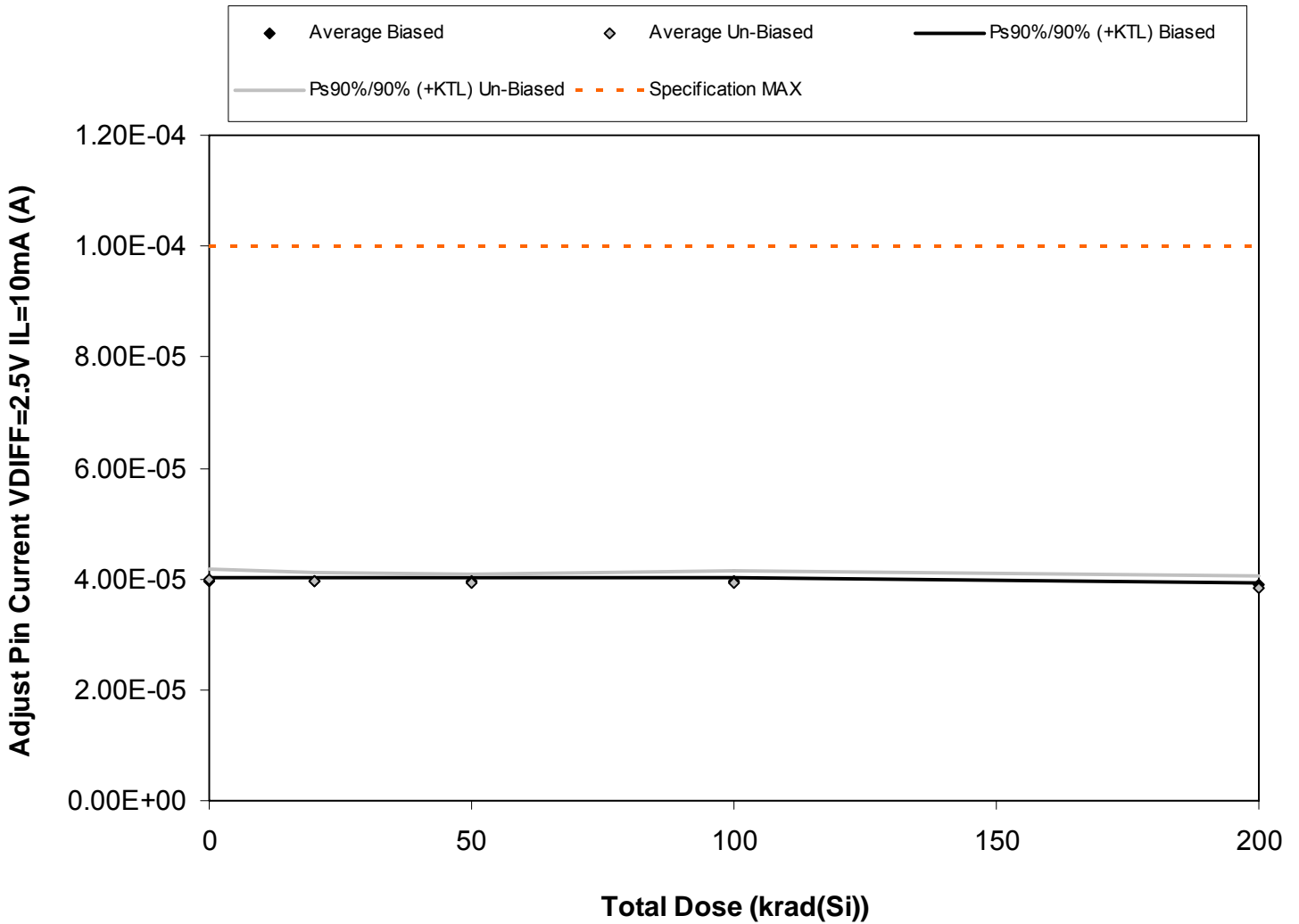

Figure 5.8. Plot of Adjust Pin Current VDIFF=2.5V IL=10mA (A) versus total dose. The solid diamonds are the average of the measured data points for the samples irradiated under electrical bias while the shaded diamonds are the average of the measured data points for the samples irradiated with all pins tied to ground. The black lines (solid and/or dashed) are the average of the data points after application of the KTL statistics on the samples irradiated under electrical bias while the gray lines (solid and/or dashed) are the average of the data points after application of the KTL statistics on the samples irradiated in the unbiased condition. The red dotted line(s) are the pre- and/or post-irradiation minimum and/or maximum specification value as defined in the datasheet and/or test plan.



Table 5.8. Raw data for Adjust Pin Current VDIFF=2.5V IL=10mA (A) versus total dose, including the statistical analysis, specification and the status of the testing (pass/fail).

| Adjust Pin Current VDIFF=2.5V IL=10mA (A) | | Total Dose (krad(Si)) | | | | |
|---|----------------------------|-----------------------|-----------------|-----------------|-----------------|-----------------|
| | | 0 | 20 | 50 | 100 | 200 |
| Device | | | | | | |
| | 57 | 3.96E-05 | 3.98E-05 | 3.97E-05 | 3.99E-05 | 3.92E-05 |
| | 58 | 3.96E-05 | 3.98E-05 | 3.98E-05 | 3.99E-05 | 3.90E-05 |
| | 59 | 3.99E-05 | 3.98E-05 | 3.98E-05 | 3.99E-05 | 3.92E-05 |
| | 60 | 3.94E-05 | 3.96E-05 | 3.95E-05 | 3.97E-05 | 3.88E-05 |
| | 92 | 3.94E-05 | 3.94E-05 | 3.93E-05 | 3.94E-05 | 3.88E-05 |
| | 93 | 4.03E-05 | 4.00E-05 | 3.99E-05 | 3.99E-05 | 3.90E-05 |
| | 94 | 3.87E-05 | 3.89E-05 | 3.88E-05 | 3.83E-05 | 3.78E-05 |
| | 95 | 4.04E-05 | 4.02E-05 | 3.98E-05 | 3.99E-05 | 3.90E-05 |
| | 97 | 4.02E-05 | 3.98E-05 | 3.98E-05 | 3.99E-05 | 3.90E-05 |
| | 98 | 3.93E-05 | 3.89E-05 | 3.88E-05 | 3.90E-05 | 3.74E-05 |
| | 99 | 4.10E-05 | 4.02E-05 | 4.06E-05 | 4.05E-05 | 3.99E-05 |
| | 100 | 4.01E-05 | 3.98E-05 | 3.98E-05 | 3.99E-05 | 3.93E-05 |
| Biased Statistics | | | | | | |
| | Average Biased | 3.96E-05 | 3.97E-05 | 3.96E-05 | 3.97E-05 | 3.90E-05 |
| | Std Dev Biased | 2.08E-07 | 1.70E-07 | 1.95E-07 | 1.93E-07 | 1.55E-07 |
| | Ps90%/90% (+KTL) Biased | 4.02E-05 | 4.01E-05 | 4.02E-05 | 4.03E-05 | 3.94E-05 |
| | Ps90%/90% (-KTL) Biased | 3.90E-05 | 3.92E-05 | 3.91E-05 | 3.92E-05 | 3.86E-05 |
| Un-Biased Statistics | | | | | | |
| | Average Un-Biased | 3.98E-05 | 3.96E-05 | 3.94E-05 | 3.94E-05 | 3.84E-05 |
| | Std Dev Un-Biased | 7.44E-07 | 6.18E-07 | 5.63E-07 | 7.27E-07 | 7.58E-07 |
| | Ps90%/90% (+KTL) Un-Biased | 4.18E-05 | 4.13E-05 | 4.10E-05 | 4.14E-05 | 4.05E-05 |
| | Ps90%/90% (-KTL) Un-Biased | 3.77E-05 | 3.79E-05 | 3.79E-05 | 3.74E-05 | 3.63E-05 |
| | Specification MAX | 1.00E-04 | 1.00E-04 | 1.00E-04 | 1.00E-04 | 1.00E-04 |
| | Status | PASS | PASS | PASS | PASS | PASS |

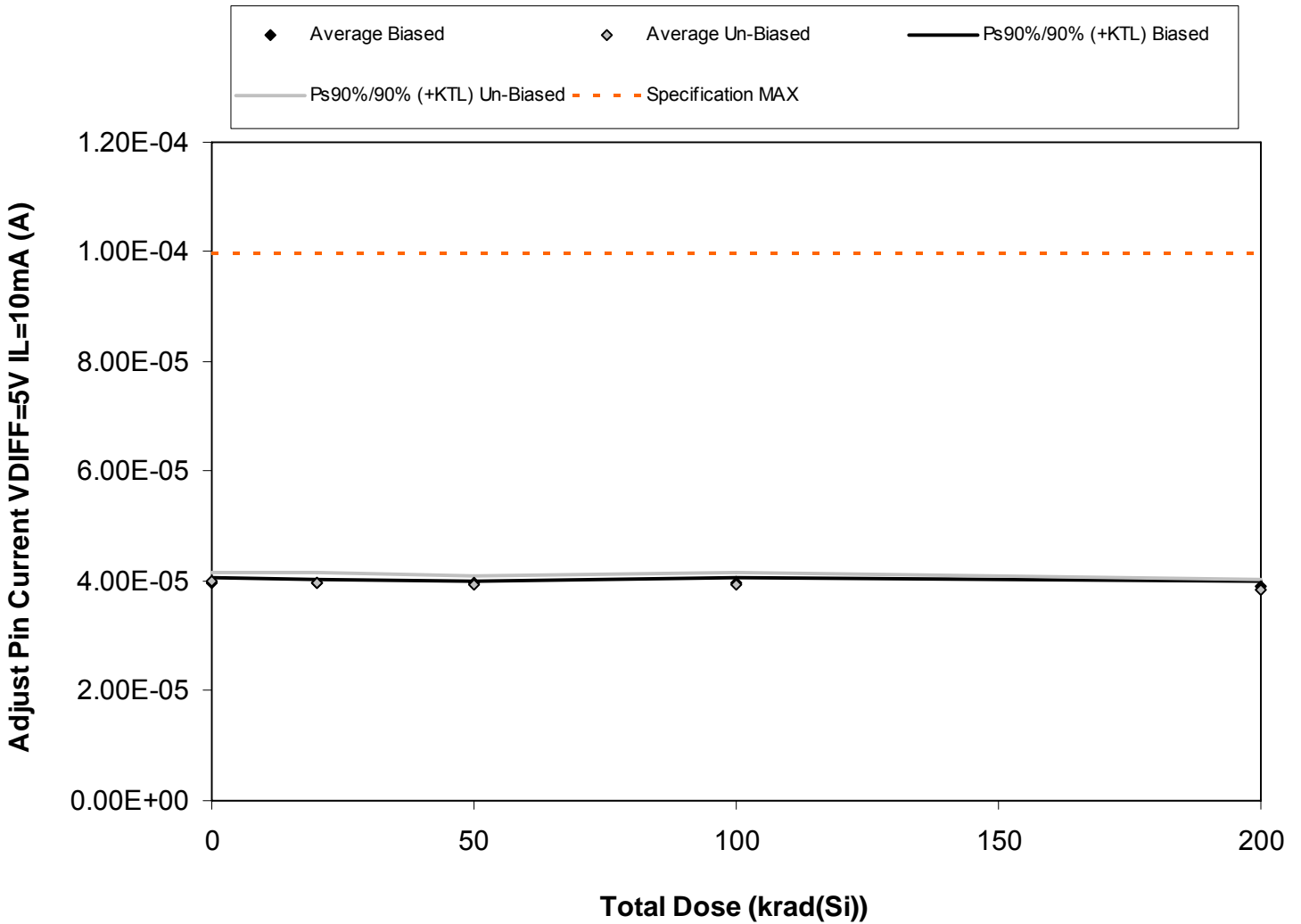

Figure 5.9. Plot of Adjust Pin Current VDIFF=5V IL=10mA (A) versus total dose. The solid diamonds are the average of the measured data points for the samples irradiated under electrical bias while the shaded diamonds are the average of the measured data points for the samples irradiated with all pins tied to ground. The black lines (solid and/or dashed) are the average of the data points after application of the KTL statistics on the samples irradiated under electrical bias while the gray lines (solid and/or dashed) are the average of the data points after application of the KTL statistics on the samples irradiated in the unbiased condition. The red dotted line(s) are the pre- and/or post-irradiation minimum and/or maximum specification value as defined in the datasheet and/or test plan.



Table 5.9. Raw data for Adjust Pin Current VDIFF=5V IL=10mA (A) versus total dose, including the statistical analysis, specification and the status of the testing (pass/fail).

| Adjust Pin Current VDIFF=5V IL=10mA (A) | Total Dose (krad(Si)) | | | | |
|---|-----------------------|-----------------|-----------------|-----------------|-----------------|
| | 0 | 20 | 50 | 100 | 200 |
| Device | | | | | |
| 57 | 3.96E-05 | 3.98E-05 | 3.97E-05 | 3.97E-05 | 3.91E-05 |
| 58 | 4.02E-05 | 3.97E-05 | 3.97E-05 | 3.99E-05 | 3.97E-05 |
| 59 | 4.02E-05 | 3.98E-05 | 3.98E-05 | 3.99E-05 | 3.90E-05 |
| 60 | 3.98E-05 | 3.97E-05 | 3.94E-05 | 3.99E-05 | 3.88E-05 |
| 92 | 3.95E-05 | 3.93E-05 | 3.94E-05 | 3.92E-05 | 3.88E-05 |
| 93 | 4.04E-05 | 4.01E-05 | 3.98E-05 | 3.99E-05 | 3.92E-05 |
| 94 | 3.91E-05 | 3.87E-05 | 3.87E-05 | 3.83E-05 | 3.78E-05 |
| 95 | 4.04E-05 | 4.04E-05 | 3.99E-05 | 3.99E-05 | 3.90E-05 |
| 97 | 4.02E-05 | 3.98E-05 | 3.98E-05 | 3.99E-05 | 3.90E-05 |
| 98 | 3.93E-05 | 3.89E-05 | 3.88E-05 | 3.85E-05 | 3.79E-05 |
| 99 | 4.06E-05 | 4.01E-05 | 4.04E-05 | 4.05E-05 | 4.01E-05 |
| 100 | 4.02E-05 | 3.97E-05 | 3.98E-05 | 3.98E-05 | 3.93E-05 |
| Biased Statistics | | | | | |
| Average Biased | 3.98E-05 | 3.96E-05 | 3.96E-05 | 3.97E-05 | 3.91E-05 |
| Std Dev Biased | 3.02E-07 | 2.11E-07 | 1.68E-07 | 2.90E-07 | 3.60E-07 |
| Ps90%/90% (+KTL) Biased | 4.07E-05 | 4.02E-05 | 4.01E-05 | 4.05E-05 | 4.01E-05 |
| Ps90%/90% (-KTL) Biased | 3.90E-05 | 3.91E-05 | 3.91E-05 | 3.89E-05 | 3.81E-05 |
| Un-Biased Statistics | | | | | |
| Average Un-Biased | 3.99E-05 | 3.96E-05 | 3.94E-05 | 3.93E-05 | 3.86E-05 |
| Std Dev Un-Biased | 6.40E-07 | 7.60E-07 | 5.98E-07 | 8.08E-07 | 6.60E-07 |
| Ps90%/90% (+KTL) Un-Biased | 4.16E-05 | 4.16E-05 | 4.10E-05 | 4.15E-05 | 4.04E-05 |
| Ps90%/90% (-KTL) Un-Biased | 3.81E-05 | 3.75E-05 | 3.78E-05 | 3.71E-05 | 3.67E-05 |
| Specification MAX | 1.00E-04 | 1.00E-04 | 1.00E-04 | 1.00E-04 | 1.00E-04 |
| Status | PASS | PASS | PASS | PASS | PASS |

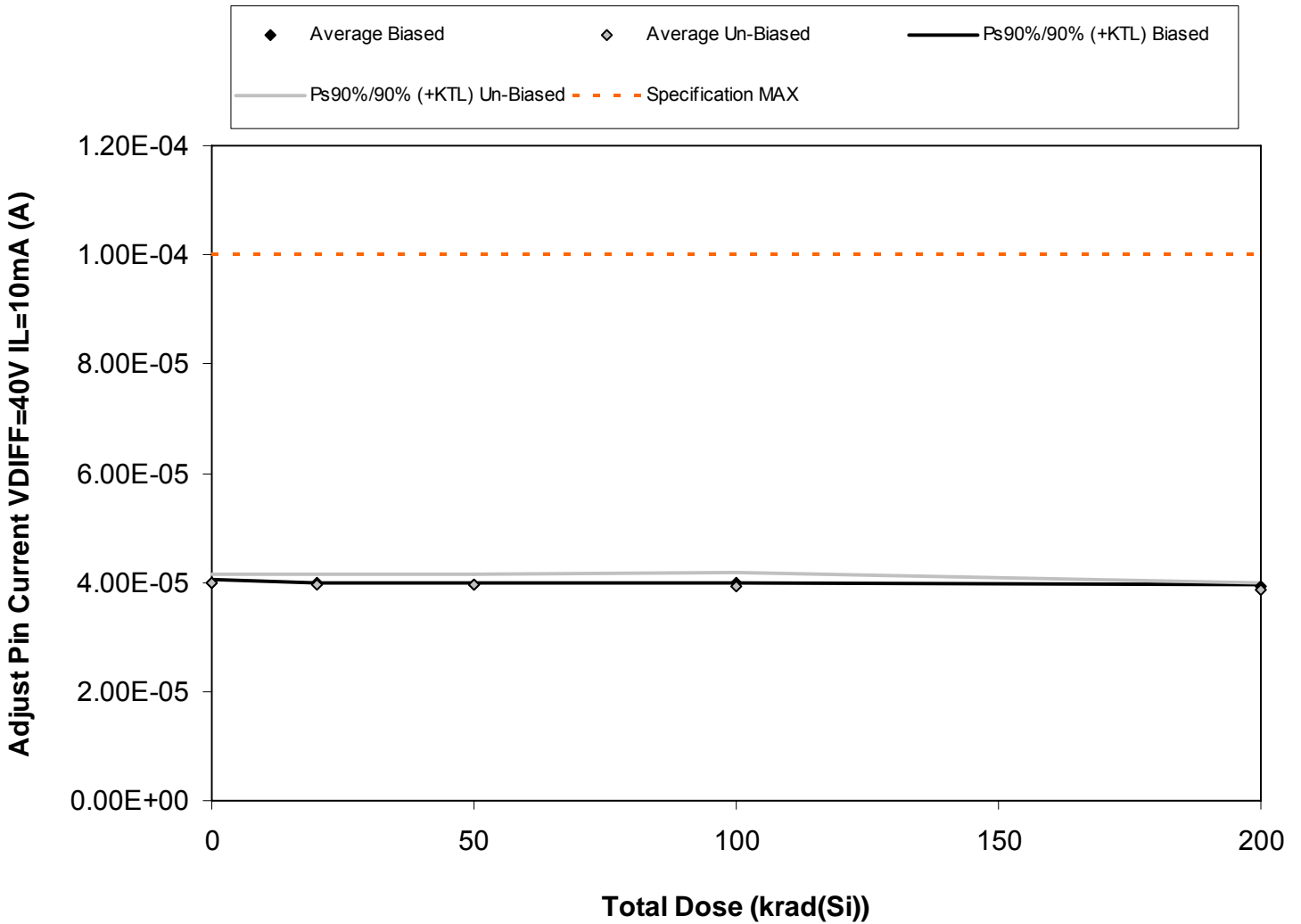

Figure 5.10. Plot of Adjust Pin Current VDIFF=40V IL=10mA (A) versus total dose. The solid diamonds are the average of the measured data points for the samples irradiated under electrical bias while the shaded diamonds are the average of the measured data points for the samples irradiated with all pins tied to ground. The black lines (solid and/or dashed) are the average of the data points after application of the KTL statistics on the samples irradiated under electrical bias while the gray lines (solid and/or dashed) are the average of the data points after application of the KTL statistics on the samples irradiated in the unbiased condition. The red dotted line(s) are the pre- and/or post-irradiation minimum and/or maximum specification value as defined in the datasheet and/or test plan.



Table 5.10. Raw data for Adjust Pin Current VDIFF=40V IL=10mA (A) versus total dose, including the statistical analysis, specification and the status of the testing (pass/fail).

| Adjust Pin Current VDIFF=40V IL=10mA (A) | | Total Dose (krad(Si)) | | | | |
|--|----------------------------|-----------------------|-----------------|-----------------|-----------------|-----------------|
| | | 0 | 20 | 50 | 100 | 200 |
| Device | | | | | | |
| | 57 | 3.95E-05 | 3.98E-05 | 3.97E-05 | 3.99E-05 | 3.93E-05 |
| | 58 | 4.00E-05 | 3.98E-05 | 3.98E-05 | 3.99E-05 | 3.94E-05 |
| | 59 | 4.02E-05 | 3.98E-05 | 3.98E-05 | 3.99E-05 | 3.91E-05 |
| | 60 | 3.96E-05 | 3.96E-05 | 3.95E-05 | 3.99E-05 | 3.90E-05 |
| | 92 | 3.95E-05 | 3.98E-05 | 3.97E-05 | 3.99E-05 | 3.90E-05 |
| | 93 | 4.02E-05 | 4.02E-05 | 4.03E-05 | 4.01E-05 | 3.90E-05 |
| | 94 | 3.93E-05 | 3.89E-05 | 3.87E-05 | 3.83E-05 | 3.81E-05 |
| | 95 | 4.05E-05 | 4.04E-05 | 4.01E-05 | 4.00E-05 | 3.90E-05 |
| | 97 | 4.02E-05 | 4.00E-05 | 3.98E-05 | 4.00E-05 | 3.91E-05 |
| | 98 | 3.92E-05 | 3.89E-05 | 3.89E-05 | 3.86E-05 | 3.81E-05 |
| | 99 | 4.09E-05 | 4.04E-05 | 4.04E-05 | 4.08E-05 | 4.01E-05 |
| | 100 | 4.02E-05 | 3.98E-05 | 3.98E-05 | 3.99E-05 | 3.93E-05 |
| Biased Statistics | | | | | | |
| | Average Biased | 3.98E-05 | 3.98E-05 | 3.97E-05 | 3.99E-05 | 3.92E-05 |
| | Std Dev Biased | 2.94E-07 | 8.67E-08 | 1.10E-07 | 0.00E+00 | 2.11E-07 |
| | Ps90%/90% (+KTL) Biased | 4.06E-05 | 4.00E-05 | 4.00E-05 | 3.99E-05 | 3.97E-05 |
| | Ps90%/90% (-KTL) Biased | 3.89E-05 | 3.95E-05 | 3.94E-05 | 3.99E-05 | 3.86E-05 |
| Un-Biased Statistics | | | | | | |
| | Average Un-Biased | 3.99E-05 | 3.97E-05 | 3.96E-05 | 3.94E-05 | 3.86E-05 |
| | Std Dev Un-Biased | 5.96E-07 | 7.17E-07 | 7.04E-07 | 8.68E-07 | 5.05E-07 |
| | Ps90%/90% (+KTL) Un-Biased | 4.15E-05 | 4.16E-05 | 4.15E-05 | 4.18E-05 | 4.00E-05 |
| | Ps90%/90% (-KTL) Un-Biased | 3.82E-05 | 3.77E-05 | 3.76E-05 | 3.70E-05 | 3.72E-05 |
| | Specification MAX | 1.00E-04 | 1.00E-04 | 1.00E-04 | 1.00E-04 | 1.00E-04 |
| | Status | PASS | PASS | PASS | PASS | PASS |

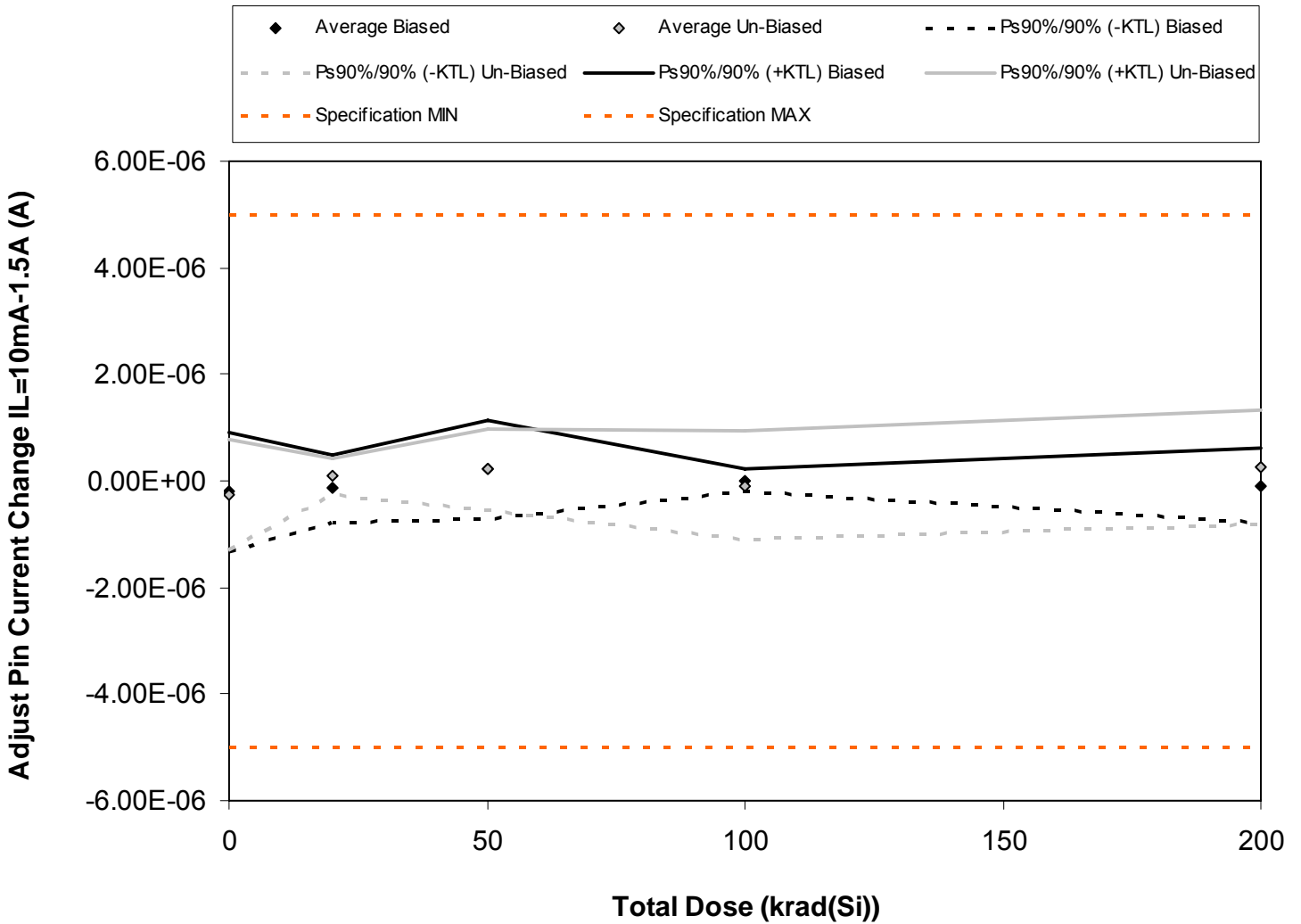

Figure 5.11. Plot of Adjust Pin Current Change IL=10mA-1.5A (A) versus total dose. The solid diamonds are the average of the measured data points for the samples irradiated under electrical bias while the shaded diamonds are the average of the measured data points for the samples irradiated with all pins tied to ground. The black lines (solid and/or dashed) are the average of the data points after application of the KTL statistics on the samples irradiated under electrical bias while the gray lines (solid and/or dashed) are the average of the data points after application of the KTL statistics on the samples irradiated in the unbiased condition. The red dotted line(s) are the pre- and/or post-irradiation minimum and/or maximum specification value as defined in the datasheet and/or test plan.



Table 5.11. Raw data for Adjust Pin Current Change IL=10mA-1.5A (A) versus total dose, including the statistical analysis, specification and the status of the testing (pass/fail).

| Adjust Pin Current Change IL=10mA-1.5A (A) | Total Dose (krad(Si)) | | | | |
|--|-----------------------|------------------|------------------|------------------|------------------|
| | 0 | 20 | 50 | 100 | 200 |
| Device | | | | | |
| 57 | 2.00E-08 | 0.00E+00 | -2.70E-07 | 0.00E+00 | 1.80E-07 |
| 58 | -2.70E-07 | 0.00E+00 | 3.10E-07 | 0.00E+00 | -4.70E-07 |
| 59 | -9.00E-08 | 0.00E+00 | 0.00E+00 | 0.00E+00 | 4.00E-08 |
| 60 | -8.70E-07 | -1.60E-07 | 5.30E-07 | 1.30E-07 | -2.20E-07 |
| 92 | 1.80E-07 | -5.30E-07 | 4.90E-07 | -9.00E-08 | 0.00E+00 |
| 93 | -4.50E-07 | 2.90E-07 | 2.00E-08 | -2.20E-07 | 0.00E+00 |
| 94 | 1.60E-07 | 0.00E+00 | 5.80E-07 | 4.00E-07 | 3.60E-07 |
| 95 | -8.00E-07 | 4.00E-08 | 4.00E-08 | 0.00E+00 | 0.00E+00 |
| 97 | 0.00E+00 | 9.00E-08 | 0.00E+00 | 0.00E+00 | 0.00E+00 |
| 98 | -1.80E-07 | 0.00E+00 | 4.50E-07 | -6.20E-07 | 8.90E-07 |
| 99 | 1.80E-07 | -4.70E-07 | 2.50E-07 | -2.70E-07 | 7.00E-08 |
| 100 | -9.00E-08 | 0.00E+00 | 0.00E+00 | 0.00E+00 | -3.60E-07 |
| Biased Statistics | | | | | |
| Average Biased | -2.06E-07 | -1.38E-07 | 2.12E-07 | 8.00E-09 | -9.40E-08 |
| Std Dev Biased | 4.06E-07 | 2.30E-07 | 3.41E-07 | 7.85E-08 | 2.55E-07 |
| Ps90%/90% (+KTL) Biased | 9.07E-07 | 4.92E-07 | 1.15E-06 | 2.23E-07 | 6.04E-07 |
| Ps90%/90% (-KTL) Biased | -1.32E-06 | -7.68E-07 | -7.23E-07 | -2.07E-07 | -7.92E-07 |
| Un-Biased Statistics | | | | | |
| Average Un-Biased | -2.54E-07 | 8.40E-08 | 2.18E-07 | -8.80E-08 | 2.50E-07 |
| Std Dev Un-Biased | 3.80E-07 | 1.21E-07 | 2.75E-07 | 3.72E-07 | 3.90E-07 |
| Ps90%/90% (+KTL) Un-Biased | 7.88E-07 | 4.16E-07 | 9.73E-07 | 9.33E-07 | 1.32E-06 |
| Ps90%/90% (-KTL) Un-Biased | -1.30E-06 | -2.48E-07 | -5.37E-07 | -1.11E-06 | -8.20E-07 |
| Specification MIN | -5.00E-06 | -5.00E-06 | -5.00E-06 | -5.00E-06 | -5.00E-06 |
| Status | PASS | PASS | PASS | PASS | PASS |
| Specification MAX | 5.00E-06 | 5.00E-06 | 5.00E-06 | 5.00E-06 | 5.00E-06 |
| Status | PASS | PASS | PASS | PASS | PASS |

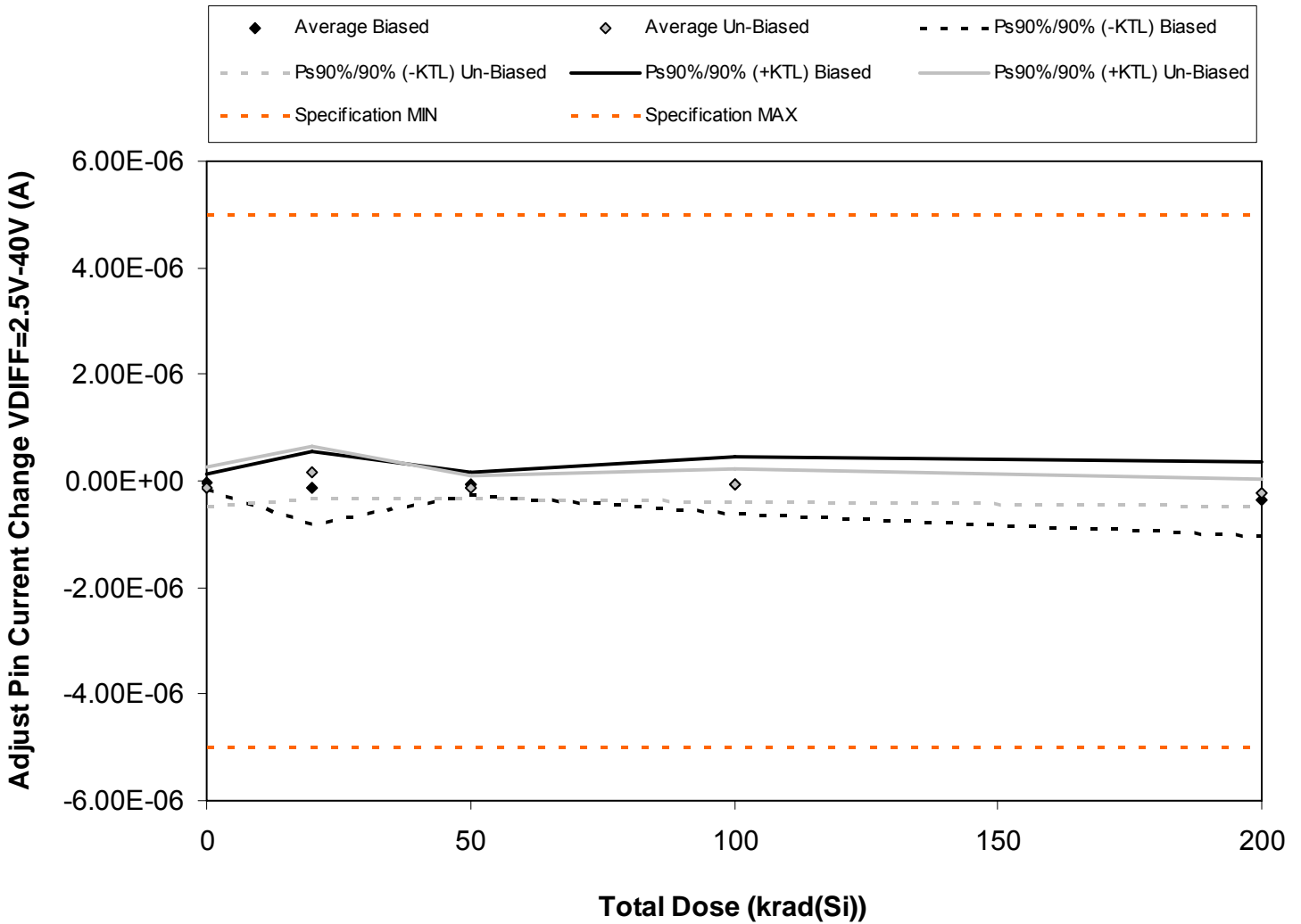

Figure 5.12. Plot of Adjust Pin Current Change VDIFF=2.5V-40V (A) versus total dose. The solid diamonds are the average of the measured data points for the samples irradiated under electrical bias while the shaded diamonds are the average of the measured data points for the samples irradiated with all pins tied to ground. The black lines (solid and/or dashed) are the average of the data points after application of the KTL statistics on the samples irradiated under electrical bias while the gray lines (solid and/or dashed) are the average of the data points after application of the KTL statistics on the samples irradiated in the unbiased condition. The red dotted line(s) are the pre- and/or post-irradiation minimum and/or maximum specification value as defined in the datasheet and/or test plan.



Table 5.12. Raw data for Adjust Pin Current Change VDIFF=2.5V-40V (A) versus total dose, including the statistical analysis, specification and the status of the testing (pass/fail).

| Adjust Pin Current Change VDIFF=2.5V-40V (A) | Total Dose (krad(Si)) | | | | |
|--|-----------------------|------------------|------------------|------------------|------------------|
| | 0 | 20 | 50 | 100 | 200 |
| Device | | | | | |
| 57 | -4.00E-08 | -9.00E-08 | 0.00E+00 | -3.10E-07 | -2.00E-08 |
| 58 | 0.00E+00 | 0.00E+00 | -9.00E-08 | 9.00E-08 | -6.20E-07 |
| 59 | 0.00E+00 | 0.00E+00 | 0.00E+00 | 0.00E+00 | -5.80E-07 |
| 60 | -1.10E-07 | 0.00E+00 | -1.80E-07 | -2.70E-07 | -3.10E-07 |
| 92 | 4.00E-08 | -5.80E-07 | 0.00E+00 | 9.00E-08 | -1.80E-07 |
| 93 | -1.80E-07 | 3.30E-07 | -1.30E-07 | -9.00E-08 | -4.00E-07 |
| 94 | -9.00E-08 | 9.00E-08 | -2.00E-07 | -2.70E-07 | -1.80E-07 |
| 95 | -3.10E-07 | 3.80E-07 | -2.00E-07 | 0.00E+00 | -1.80E-07 |
| 97 | 0.00E+00 | 2.00E-08 | -2.00E-08 | 0.00E+00 | -1.80E-07 |
| 98 | 0.00E+00 | 0.00E+00 | -9.00E-08 | -4.00E-08 | -1.80E-07 |
| 99 | 1.30E-07 | -1.80E-07 | -1.30E-07 | 7.00E-08 | -2.90E-07 |
| 100 | 0.00E+00 | 0.00E+00 | 0.00E+00 | -9.00E-08 | -9.00E-08 |
| Biased Statistics | | | | | |
| Average Biased | -2.20E-08 | -1.34E-07 | -5.40E-08 | -8.00E-08 | -3.42E-07 |
| Std Dev Biased | 5.67E-08 | 2.52E-07 | 8.05E-08 | 1.96E-07 | 2.57E-07 |
| Ps90%/90% (+KTL) Biased | 1.34E-07 | 5.58E-07 | 1.67E-07 | 4.57E-07 | 3.64E-07 |
| Ps90%/90% (-KTL) Biased | -1.78E-07 | -8.26E-07 | -2.75E-07 | -6.17E-07 | -1.05E-06 |
| Un-Biased Statistics | | | | | |
| Average Un-Biased | -1.16E-07 | 1.64E-07 | -1.28E-07 | -8.00E-08 | -2.24E-07 |
| Std Dev Un-Biased | 1.32E-07 | 1.78E-07 | 7.66E-08 | 1.12E-07 | 9.84E-08 |
| Ps90%/90% (+KTL) Un-Biased | 2.45E-07 | 6.53E-07 | 8.21E-08 | 2.28E-07 | 4.58E-08 |
| Ps90%/90% (-KTL) Un-Biased | -4.77E-07 | -3.25E-07 | -3.38E-07 | -3.88E-07 | -4.94E-07 |
| Specification MIN | -5.00E-06 | -5.00E-06 | -5.00E-06 | -5.00E-06 | -5.00E-06 |
| Status | PASS | PASS | PASS | PASS | PASS |
| Specification MAX | 5.00E-06 | 5.00E-06 | 5.00E-06 | 5.00E-06 | 5.00E-06 |
| Status | PASS | PASS | PASS | PASS | PASS |

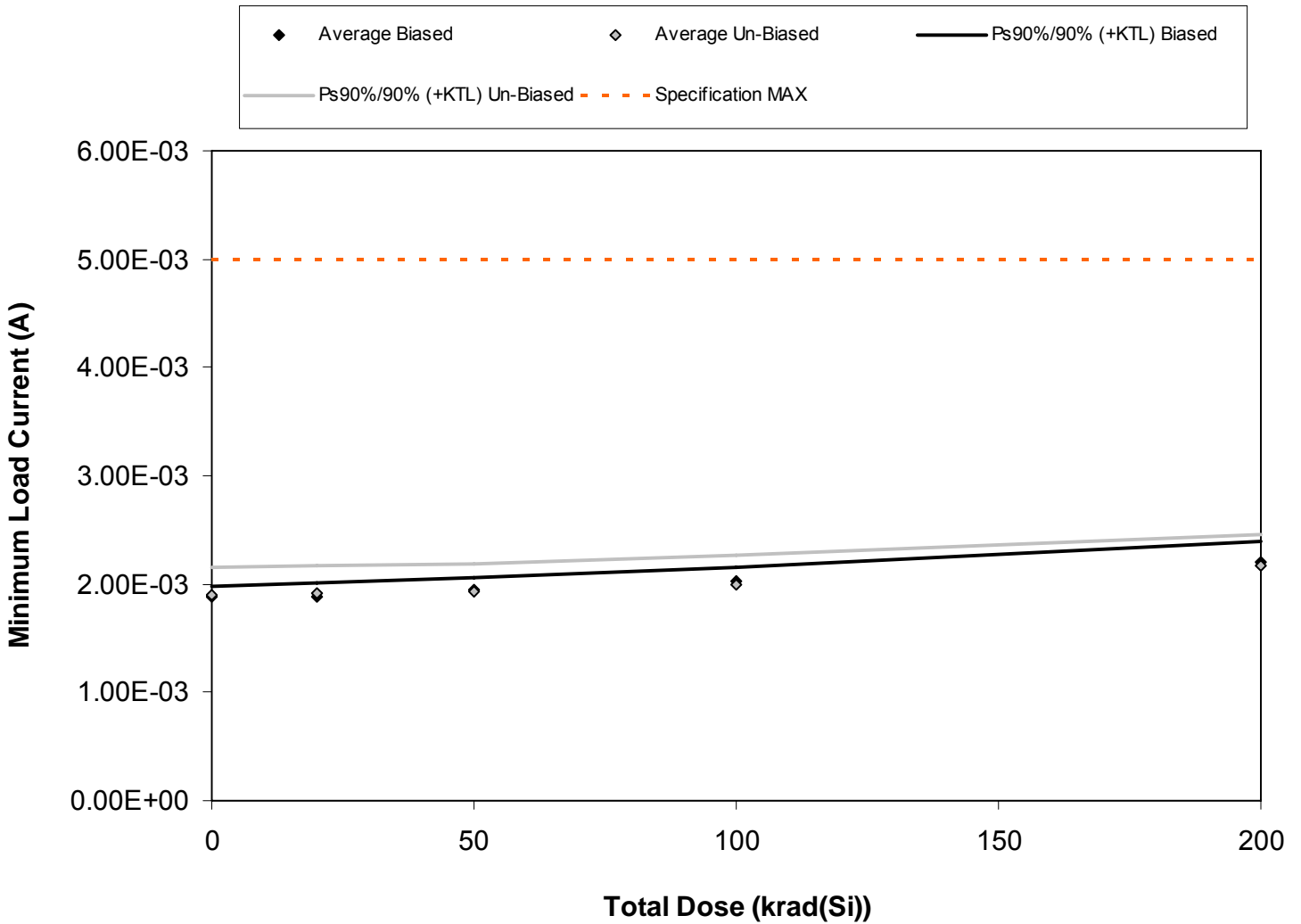

Figure 5.13. Plot of Minimum Load Current (A) versus total dose. The solid diamonds are the average of the measured data points for the samples irradiated under electrical bias while the shaded diamonds are the average of the measured data points for the samples irradiated with all pins tied to ground. The black lines (solid and/or dashed) are the average of the data points after application of the KTL statistics on the samples irradiated under electrical bias while the gray lines (solid and/or dashed) are the average of the data points after application of the KTL statistics on the samples irradiated in the unbiased condition. The red dotted line(s) are the pre- and/or post-irradiation minimum and/or maximum specification value as defined in the datasheet and/or test plan.



Table 5.13. Raw data for Minimum Load Current (A) versus total dose, including the statistical analysis, specification and the status of the testing (pass/fail).

| Minimum Load Current (A) | Total Dose (krad(Si)) | | | | |
|-----------------------------|-----------------------|-----------------|-----------------|-----------------|-----------------|
| | 0 | 20 | 50 | 100 | 200 |
| Device | | | | | |
| 57 | 1.93E-03 | 1.93E-03 | 1.96E-03 | 2.02E-03 | 2.18E-03 |
| 58 | 1.87E-03 | 1.89E-03 | 1.98E-03 | 2.08E-03 | 2.32E-03 |
| 59 | 1.85E-03 | 1.83E-03 | 1.89E-03 | 1.96E-03 | 2.14E-03 |
| 60 | 1.91E-03 | 1.93E-03 | 1.98E-03 | 2.06E-03 | 2.24E-03 |
| 92 | 1.85E-03 | 1.85E-03 | 1.91E-03 | 2.00E-03 | 2.18E-03 |
| 93 | 1.93E-03 | 1.96E-03 | 1.98E-03 | 2.06E-03 | 2.24E-03 |
| 94 | 1.81E-03 | 1.81E-03 | 1.83E-03 | 1.87E-03 | 2.06E-03 |
| 95 | 1.95E-03 | 1.96E-03 | 1.98E-03 | 2.06E-03 | 2.28E-03 |
| 97 | 2.02E-03 | 2.02E-03 | 2.04E-03 | 2.06E-03 | 2.24E-03 |
| 98 | 1.83E-03 | 1.85E-03 | 1.85E-03 | 1.90E-03 | 2.06E-03 |
| 99 | 1.93E-03 | 1.95E-03 | 1.95E-03 | 1.94E-03 | 1.92E-03 |
| 100 | 1.87E-03 | 1.89E-03 | 1.89E-03 | 1.89E-03 | 1.89E-03 |
| Biased Statistics | | | | | |
| Average Biased | 1.88E-03 | 1.88E-03 | 1.94E-03 | 2.03E-03 | 2.21E-03 |
| Std Dev Biased | 3.63E-05 | 4.56E-05 | 4.38E-05 | 4.79E-05 | 7.01E-05 |
| Ps90%/90% (+KTL) Biased | 1.98E-03 | 2.01E-03 | 2.06E-03 | 2.16E-03 | 2.40E-03 |
| Ps90%/90% (-KTL) Biased | 1.78E-03 | 1.76E-03 | 1.82E-03 | 1.89E-03 | 2.02E-03 |
| Un-Biased Statistics | | | | | |
| Average Un-Biased | 1.90E-03 | 1.92E-03 | 1.93E-03 | 1.99E-03 | 2.18E-03 |
| Std Dev Un-Biased | 8.86E-05 | 8.92E-05 | 9.34E-05 | 9.80E-05 | 1.04E-04 |
| Ps90%/90% (+KTL) Un-Biased | 2.15E-03 | 2.16E-03 | 2.19E-03 | 2.26E-03 | 2.46E-03 |
| Ps90%/90% (-KTL) Un-Biased | 1.66E-03 | 1.67E-03 | 1.68E-03 | 1.72E-03 | 1.89E-03 |
| Specification MAX | 5.00E-03 | 5.00E-03 | 5.00E-03 | 5.00E-03 | 5.00E-03 |
| Status | PASS | PASS | PASS | PASS | PASS |

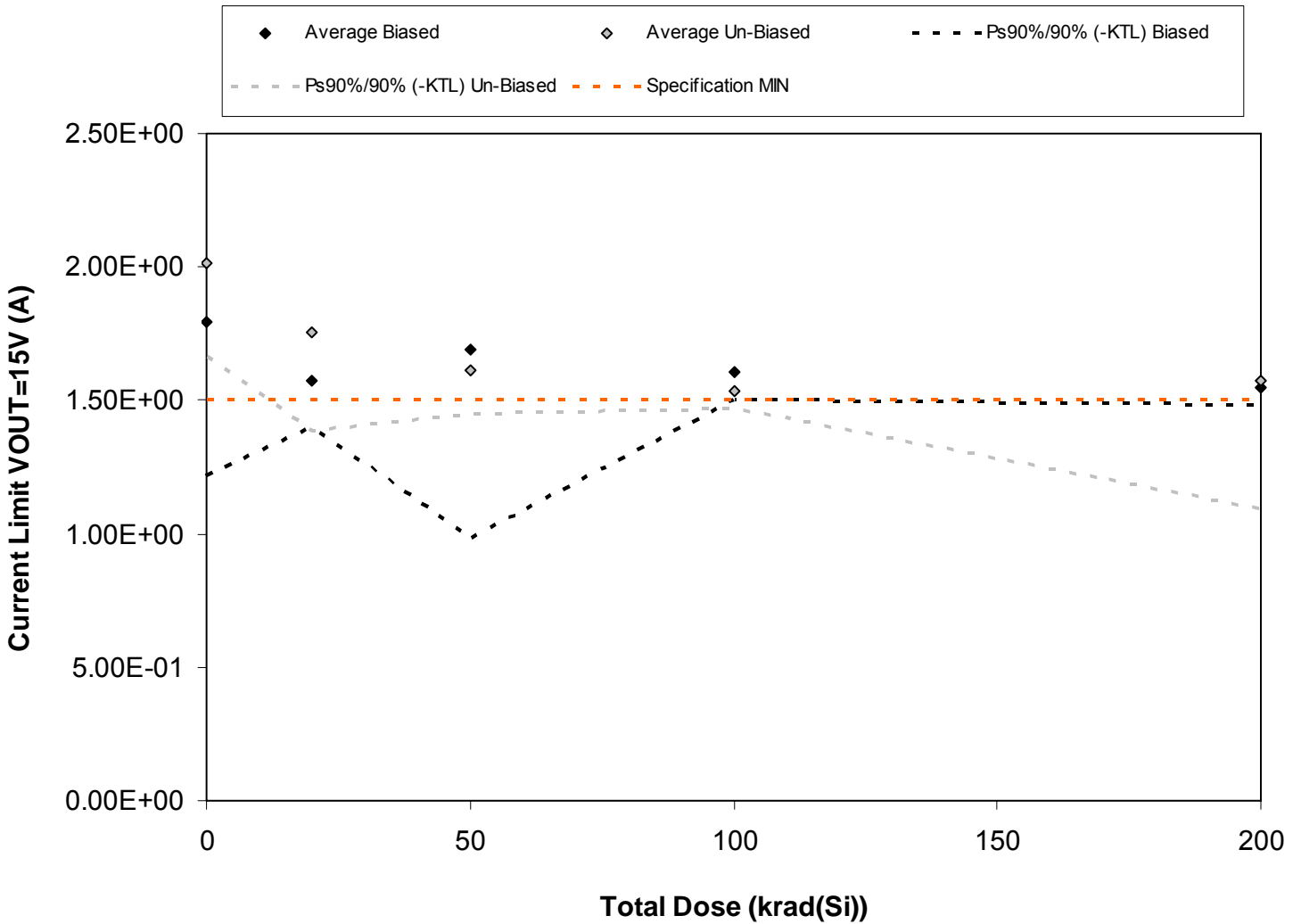

Figure 5.14. Plot of Current Limit VOUT=15V (A) versus total dose. The solid diamonds are the average of the measured data points for the samples irradiated under electrical bias while the shaded diamonds are the average of the measured data points for the samples irradiated with all pins tied to ground. The black lines (solid and/or dashed) are the average of the data points after application of the KTL statistics on the samples irradiated under electrical bias while the gray lines (solid and/or dashed) are the average of the data points after application of the KTL statistics on the samples irradiated in the unbiased condition. The red dotted line(s) are the pre- and/or post-irradiation minimum and/or maximum specification value as defined in the datasheet and/or test plan.



Table 5.14. Raw data for Current Limit VOUT=15V (A) versus total dose, including the statistical analysis, specification and the status of the testing (pass/fail).

| Current Limit VOUT=15V (A) | Total Dose (krad(Si)) | | | | |
|-----------------------------|-----------------------|-----------------|-----------------|-----------------|-----------------|
| | 0 | 20 | 50 | 100 | 200 |
| Device | | | | | |
| 57 | 1.66E+00 | 1.53E+00 | 2.15E+00 | 1.57E+00 | 1.53E+00 |
| 58 | 2.00E+00 | 1.66E+00 | 1.66E+00 | 1.66E+00 | 1.57E+00 |
| 59 | 1.61E+00 | 1.54E+00 | 1.56E+00 | 1.57E+00 | 1.58E+00 |
| 60 | 1.66E+00 | 1.53E+00 | 1.55E+00 | 1.61E+00 | 1.53E+00 |
| 92 | 2.06E+00 | 1.64E+00 | 1.55E+00 | 1.61E+00 | 1.55E+00 |
| 93 | 2.09E+00 | 1.70E+00 | 1.55E+00 | 1.58E+00 | 1.49E+00 |
| 94 | 2.03E+00 | 1.79E+00 | 1.70E+00 | 1.53E+00 | 1.53E+00 |
| 95 | 2.08E+00 | 1.70E+00 | 1.61E+00 | 1.53E+00 | 1.45E+00 |
| 97 | 1.79E+00 | 1.61E+00 | 1.57E+00 | 1.53E+00 | 1.53E+00 |
| 98 | 2.09E+00 | 1.97E+00 | 1.61E+00 | 1.53E+00 | 1.88E+00 |
| 99 | 2.09E+00 | 1.97E+00 | 2.06E+00 | 2.01E+00 | 2.06E+00 |
| 100 | 2.06E+00 | 2.06E+00 | 2.06E+00 | 2.06E+00 | 2.05E+00 |
| Biased Statistics | | | | | |
| Average Biased | 1.80E+00 | 1.58E+00 | 1.69E+00 | 1.60E+00 | 1.55E+00 |
| Std Dev Biased | 2.12E-01 | 6.57E-02 | 2.58E-01 | 3.72E-02 | 2.51E-02 |
| Ps90%/90% (+KTL) Biased | 2.38E+00 | 1.76E+00 | 2.40E+00 | 1.71E+00 | 1.62E+00 |
| Ps90%/90% (-KTL) Biased | 1.21E+00 | 1.40E+00 | 9.85E-01 | 1.50E+00 | 1.48E+00 |
| Un-Biased Statistics | | | | | |
| Average Un-Biased | 2.02E+00 | 1.76E+00 | 1.61E+00 | 1.54E+00 | 1.57E+00 |
| Std Dev Un-Biased | 1.28E-01 | 1.35E-01 | 5.82E-02 | 2.36E-02 | 1.74E-01 |
| Ps90%/90% (+KTL) Un-Biased | 2.37E+00 | 2.13E+00 | 1.77E+00 | 1.60E+00 | 2.05E+00 |
| Ps90%/90% (-KTL) Un-Biased | 1.66E+00 | 1.39E+00 | 1.45E+00 | 1.47E+00 | 1.10E+00 |
| Specification MIN | 1.50E+00 | 1.50E+00 | 1.50E+00 | 1.50E+00 | 1.50E+00 |
| Status | PASS | PASS | PASS | PASS | PASS |

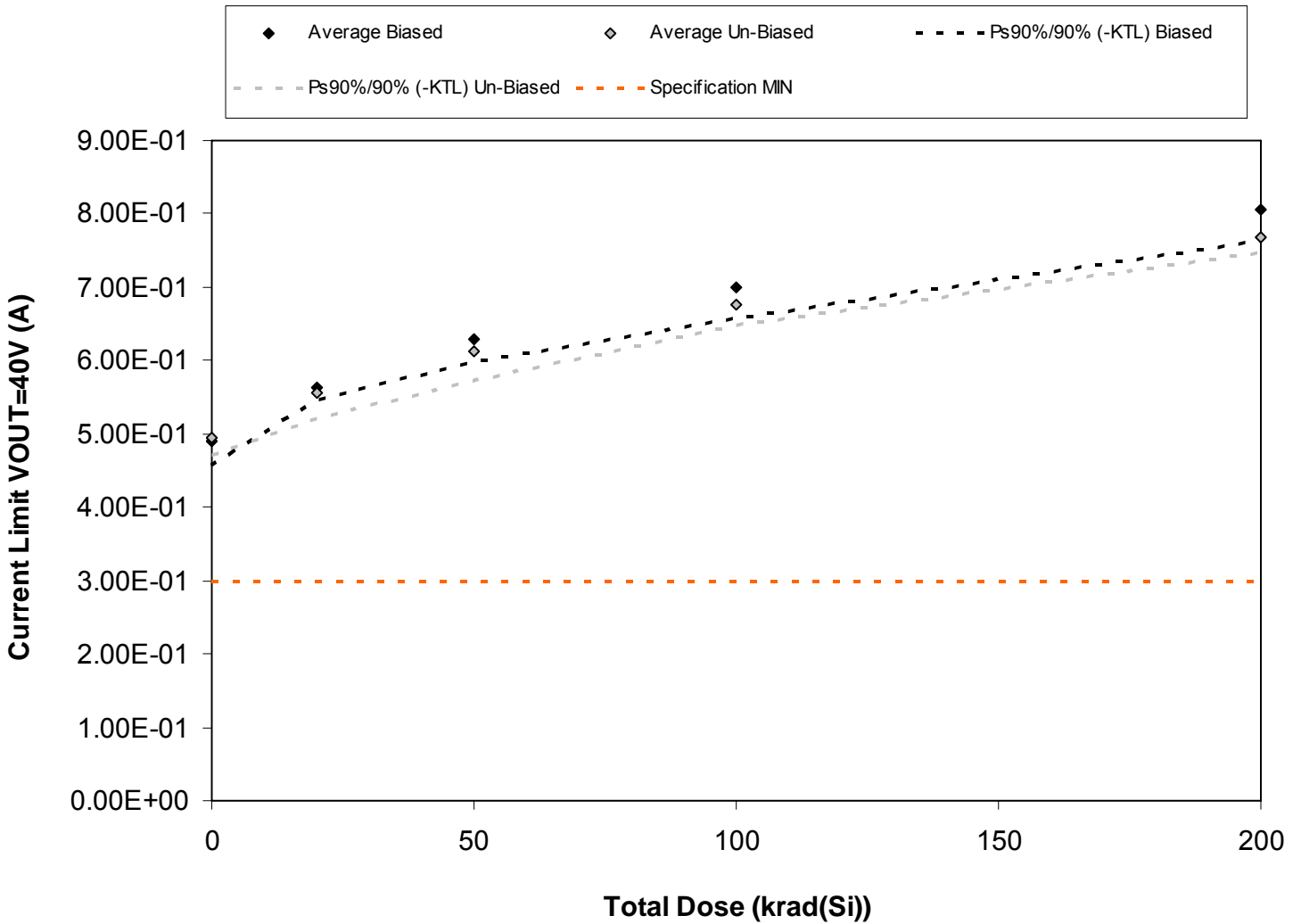

Figure 5.15. Plot of Current Limit VOUT=40V (A) versus total dose. The solid diamonds are the average of the measured data points for the samples irradiated under electrical bias while the shaded diamonds are the average of the measured data points for the samples irradiated with all pins tied to ground. The black lines (solid and/or dashed) are the average of the data points after application of the KTL statistics on the samples irradiated under electrical bias while the gray lines (solid and/or dashed) are the average of the data points after application of the KTL statistics on the samples irradiated in the unbiased condition. The red dotted line(s) are the pre- and/or post-irradiation minimum and/or maximum specification value as defined in the datasheet and/or test plan.



Table 5.15. Raw data for Current Limit VOUT=40V (A) versus total dose, including the statistical analysis, specification and the status of the testing (pass/fail).

| Current Limit VOUT=40V (A) | Total Dose (krad(Si)) | | | | |
|-----------------------------|-----------------------|-----------------|-----------------|-----------------|-----------------|
| | 0 | 20 | 50 | 100 | 200 |
| Device | | | | | |
| 57 | 4.97E-01 | 5.70E-01 | 6.36E-01 | 6.97E-01 | 8.02E-01 |
| 58 | 4.75E-01 | 5.53E-01 | 6.14E-01 | 6.86E-01 | 7.97E-01 |
| 59 | 5.02E-01 | 5.64E-01 | 6.36E-01 | 6.97E-01 | 7.91E-01 |
| 60 | 5.02E-01 | 5.64E-01 | 6.36E-01 | 7.25E-01 | 8.30E-01 |
| 92 | 4.80E-01 | 5.64E-01 | 6.20E-01 | 6.91E-01 | 8.13E-01 |
| 93 | 4.86E-01 | 5.64E-01 | 6.31E-01 | 6.86E-01 | 7.75E-01 |
| 94 | 5.02E-01 | 5.53E-01 | 6.14E-01 | 6.69E-01 | 7.58E-01 |
| 95 | 4.86E-01 | 5.36E-01 | 5.92E-01 | 6.63E-01 | 7.75E-01 |
| 97 | 4.97E-01 | 5.53E-01 | 6.09E-01 | 6.75E-01 | 7.75E-01 |
| 98 | 5.02E-01 | 5.70E-01 | 6.20E-01 | 6.86E-01 | 7.63E-01 |
| 99 | 4.91E-01 | 4.92E-01 | 4.86E-01 | 4.91E-01 | 4.91E-01 |
| 100 | 4.86E-01 | 4.92E-01 | 4.98E-01 | 4.91E-01 | 4.86E-01 |
| Biased Statistics | | | | | |
| Average Biased | 4.91E-01 | 5.63E-01 | 6.28E-01 | 6.99E-01 | 8.07E-01 |
| Std Dev Biased | 1.28E-02 | 6.16E-03 | 1.06E-02 | 1.51E-02 | 1.54E-02 |
| Ps90%/90% (+KTL) Biased | 5.26E-01 | 5.80E-01 | 6.58E-01 | 7.41E-01 | 8.49E-01 |
| Ps90%/90% (-KTL) Biased | 4.56E-01 | 5.46E-01 | 5.99E-01 | 6.58E-01 | 7.64E-01 |
| Un-Biased Statistics | | | | | |
| Average Un-Biased | 4.95E-01 | 5.55E-01 | 6.13E-01 | 6.76E-01 | 7.69E-01 |
| Std Dev Un-Biased | 8.11E-03 | 1.30E-02 | 1.44E-02 | 1.02E-02 | 8.14E-03 |
| Ps90%/90% (+KTL) Un-Biased | 5.17E-01 | 5.91E-01 | 6.53E-01 | 7.04E-01 | 7.92E-01 |
| Ps90%/90% (-KTL) Un-Biased | 4.72E-01 | 5.20E-01 | 5.74E-01 | 6.48E-01 | 7.47E-01 |
| Specification MIN | 3.00E-01 | 3.00E-01 | 3.00E-01 | 3.00E-01 | 3.00E-01 |
| Status | PASS | PASS | PASS | PASS | PASS |



6.0. Summary / Conclusions

The total ionizing dose testing described in this final report was performed using the facilities at Radiation Assured Devices' Longmire Laboratories in Colorado Springs, CO. The high dose rate total ionizing dose (TID) source is a JLSA 84-21 irradiator modified to provide a panoramic exposure. The Co-60 rods are held in the base of the irradiator heavily shielded by lead, during the radiation exposures the rod is raised by an electronic timer/controller and the exposure is performed in air. The dose rate for this irradiator in this configuration ranges from $<1\text{rad}(\text{Si})/\text{s}$ to a maximum of approximately $120\text{rad}(\text{Si})/\text{s}$, determined by the distance from the source.

The parametric data was obtained as "read and record" and all the raw data plus an attributes summary are contained in this report as well as in a separate Excel file. The attributes data contains the average, standard deviation and the average with the KTL values applied. The KTL values used is 2.742 per MIL HDBK 814 using one sided tolerance limits of 90/90 and a 5-piece sample size. This survival probability/level of confidence is consistent with a 22-piece sample size and zero failures analyzed using a lot tolerance percent defective (LTPD) approach. Note that the following criteria must be met for a device to pass the low dose rate test: following the radiation exposure each of the 5 pieces irradiated under electrical bias shall pass the specification value. The units irradiated without electrical bias and the KTL statistics are included in this report for reference only. If any of the 5 pieces irradiated under electrical bias exceed the datasheet specifications, then the lot could be logged as a failure.

Using the conditions stated above, the RH117K-Positive Adjustable Regulator (from the lot date code identified on the first page of this test report) passed the enhanced low dose rate sensitivity test to $200\text{krad}(\text{Si})$ with all parameters remaining within their pre- and/or post-radiation specification limits. As noted above (Section 4) the data for the units-under-test irradiated in the unbiased condition and the KTL statistics presented in this report are for reference only and are not used for the determination of "PASS/FAIL" for the lot.



Appendix A: Photograph of a Sample Unit-Under-Test to Show Part Traceability





Appendix B: Radiation Bias Connections

TID Radiation Biased Conditions:

| Pin | Function | Connection / Bias |
|-----------|----------|---|
| 1 | ADJ | 2k Ω to -15V |
| 2 | VIN | To 15V, 0.1 μ F decoupling to -15V |
| 3 CASE | VOUT | 61.9 Ω to -15V |

TID Radiation Unbiased Conditions:

| Pin | Function | Connection / Bias |
|-----------|----------|-------------------|
| 1 | ADJ | GND |
| 2 | VIN | GND |
| 3 CASE | VOUT | GND |

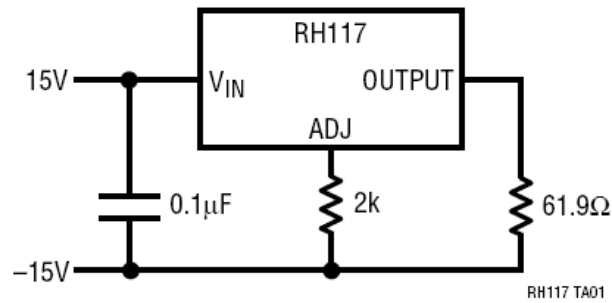

Figure B.1. Irradiation bias drawing for the units to be irradiated under electrical bias. This figure was extracted from LINEAR TECHNOLOGY CORPORATION, RH117 Datasheet.

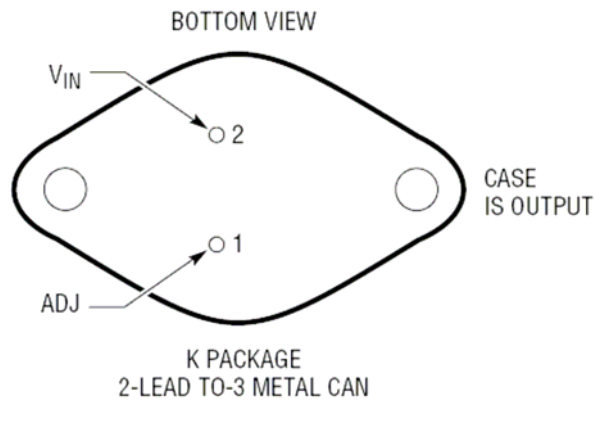

Figure B.2. K package drawing (for reference only). This figure was extracted from the LINEAR TECHNOLOGY CORPORATION RH117 Datasheet.



Appendix C: Electrical Test Parameters and Conditions

All electrical tests for this device are performed on one of Radiation Assured Device's LTS2020 Test Systems. The LTS2020 Test System is a programmable parametric tester that provides parameter measurements for a variety of digital, analog and mixed signal products including voltage regulators, voltage comparators, D to A and A to D converters. The LTS2020 Test System achieves accuracy and sensitivity through the use of software self-calibration and an internal relay matrix with separate family boards and custom personality adapter boards. The tester uses this relay matrix to connect the required test circuits, select the appropriate voltage / current sources and establish the needed measurement loops for all the tests performed. The measured parameters and test conditions are shown in Table C.1.

A listing of the measurement precision/resolution for each parameter is shown in Table C.2. The precision/resolution values were obtained from test data or from the DAC resolution of the LTS-2020 for the particular test shown, whichever is greater. To generate the precision/resolution shown in Table C.2, one of the units-under-test was tested repetitively (a total of 10-times with re-insertion between tests) to obtain the average test value and standard deviation. Using this test data MIL-HDBK-814 90/90 KTL statistics were applied to the measured standard deviation to generate the final measurement range. This value encompasses the precision/resolution of all aspects of the test system, including the LTS2020 mainframe, family board, socket assembly and DUT board as well as insertion error. In some cases, the measurement resolution is limited by the internal DACs, which results in a measured standard deviation of zero. In these instances the precision/resolution will be reported back as the LSB of the DAC.

Note that the testing and statistics used in this document are based on an “analysis of variables” technique, which relies on small sample sizes to qualify much larger lot sizes (see MIL-HDBK-814, p. 91 for a discussion of statistical treatments). Not all measured parameters are well suited to this approach due to inherent large variations. If necessary, larger samples sizes could be used to qualify these parameters using an “attributes” approach.



Table C.1. Measured parameters and test conditions for the RH117K.

| TEST DESCRIPTION | TEST CONDITIONS |
|-----------------------------------|--|
| Reference Voltage | $V_{DIFF}=V_{IN}-V_{OUT}=3V, I_L=10mA$ |
| | $V_{DIFF}=40V, I_L=10mA$ |
| | $V_{DIFF}=3V, I_L=1.5A$ |
| | $V_{DIFF}=40V, I_L=0.3A$ |
| Line Regulation | $V_{DIFF}=3V$ to $40V, I_L=10mA$ |
| Load Regulation $V_{OUT} \leq 5V$ | $V_{DIFF}=5V, V_{IN}=6.25V, I_L=10mA$ to $1.5A$ |
| Load Regulation $V_{OUT} \geq 5V$ | $V_{DIFF}=5V, V_{IN}=11.25V, I_L=10mA$ to $1.5A$ |
| Adjust Pin Current | $V_{DIFF}=2.5V, I_L=10mA$ |
| | $V_{DIFF}=5V, I_L=10mA$ |
| | $V_{DIFF}=40V, I_L=10mA$ |
| Adjust Pin Current Change | $V_{DIFF}=5V, I_L=10mA$ to $1.5A$ |
| | $V_{DIFF}=2.5V$ to $40V, I_L=10mA$ |
| Minimum Load Current | $V_{DIFF}=40V$ |
| Current Limit $V_{DIFF} \leq 15V$ | $V_{DIFF}=15V$ |
| Current Limit $V_{DIFF}=40V$ | $V_{DIFF}=40V$ |

Table C.2. Measured parameters, pre-irradiation specifications and measurement precision for the RH117K.

| Measured Parameter | Pre-Irradiation Specification | Measurement Resolution/Precision |
|-----------------------------------|-------------------------------|----------------------------------|
| Reference Voltage | $1.25V \pm 50mV$ | $\pm 1.09E-03V$ |
| Line Regulation | 0.02%/V MAX | $\pm 3.40E-04\%/V$ |
| Load Regulation $V_{OUT} \leq 5V$ | 15mV MAX | $2.40E-04V$ |
| Load Regulation $V_{OUT} \geq 5V$ | 0.3% MAX | $4.48E-03\%$ |
| Adjust Pin Current | 100 μ A MAX | $2.26E-06A$ |
| Adjust Pin Current Change | $\pm 5\mu$ A MAX | $4.20E-07A$ |
| Minimum Load Current | 5mA MAX | $2.84E-05A$ |
| Current Limit $V_{DIFF} \leq 15V$ | 1.5A MAX | $5.22E-03A$ |
| Current Limit $V_{DIFF}=40V$ | 0.3A MAX | $6.53E-03A$ |



Appendix D: List of Figures Used in Section 5 (RLAT Test Results)

- 5.1 Reference Voltage $V_{DIFF}=3V$ $I_L=10mA$ (V)
- 5.2 Reference Voltage $V_{DIFF}=40V$ $I_L=10mA$ (V)
- 5.3 Reference Voltage $V_{DIFF}=3V$ $I_L=1.5A$ (V)
- 5.4 Reference Voltage $V_{DIFF}=40V$ $I_L=0.3A$ (V)
- 5.5 Line Regulation (%/V)
- 5.6 Load Regulation $V_{OUT}\leq 5V$ (mV)
- 5.7 Load Regulation $V_{OUT}\geq 5V$ (%)
- 5.8 Adjust Pin Current $V_{DIFF}=2.5V$ $I_L=10mA$ (A)
- 5.9 Adjust Pin Current $V_{DIFF}=5V$ $I_L=10mA$ (A)
- 5.10 Adjust Pin Current $V_{DIFF}=40V$ $I_L=10mA$ (A)
- 5.11 Adjust Pin Current Change $I_L=10mA-1.5A$ (A)
- 5.12 Adjust Pin Current Change $V_{DIFF}=2.5V-40V$ (A)
- 5.13 Minimum Load Current (A)
- 5.14 Current Limit $V_{OUT}=15V$ (A)
- 5.15 Current Limit $V_{OUT}=40V$ (A)