



DSP Development Kit, Stratix II Edition

Getting Started User Guide



101 Innovation Drive
San Jose, CA 95134
(408) 544-7000
www.altera.com
P25-36008-00

Document Version: 6.0.1
Document Date: August 2006

Copyright © 2006 Altera Corporation. All rights reserved. Altera, The Programmable Solutions Company, the stylized Altera logo, specific device designations, and all other words and logos that are identified as trademarks and/or service marks are, unless noted otherwise, the trademarks and service marks of Altera Corporation in the U.S. and other countries. All other product or service names are the property of their respective holders. Altera products are protected under numerous U.S. and foreign patents and pending applications, maskwork rights, and copyrights. Altera warrants performance of its semiconductor products to current specifications in accordance with Altera's standard warranty, but reserves the right to make changes to any products and services at any time without notice. Altera assumes no responsibility or liability arising out of the application or use of any information, product, or service described herein except as expressly agreed to in writing by Altera Corporation. Altera customers are advised to obtain the latest version of device specifications before relying on any published information and before placing orders for products or services.



I.S. EN ISO 9001

UG-S29804.1.2



About this User Guide

Revision History	v
How to Contact Altera	v
Typographic Conventions	vi

Chapter 1. About this Kit

Features	1-1
----------------	-----

Chapter 2. Getting Started

System Requirements	2-1
DSP Development Kit, Stratix II Edition Contents	2-1
Inspect the Board	2-1
Software Requirements	2-2
Quartus II System Requirements	2-2
Software Installation	2-3
Installing the Quartus II Software & MegaCore Functions	2-3
Installing The MathWorks MATLAB/Simulink CD-ROM	2-3
Install DSP Builder	2-4
Installing the Reference Designs & Lab	2-5
Installing the Nios II Embedded Processor	2-7
Set Up Licensing	2-7
Connect the Cables to the Board & PC	2-8
USB Blaster Cable	2-8
SMA Cable	2-9
SLP-50 Anti-Aliasing Filter	2-10
Power Supply Cable	2-10
Using the Reference Designs & Labs	2-11
Unused Pins In Your Designs	2-12
Testing the Board Using the Factory Design	2-14
Testing LEDs & Pushbutton Switches	2-15
Performing the A/D & D/A Converter Performance Test	2-15
Conclusion	2-20



About this User Guide

Revision History

The table below displays the revision history for chapters in this user guide.

Chapter	Date	Version	Changes Made
All	October 2004	1.0.0	First release of User Guide
All	May 2005	1.1.0	Updated for Quartus II Release 5.0
All	August 2006	6.0.1	Updated for Quartus II Release 6.0 Service Pack 1



Refer to the readme file on the *DSP Development Kit, Stratix II Edition Version 6.0.1 CD-ROM* for late-breaking information that is not available in this user guide.





How to Contact Altera

For technical support or other information about Altera products, go to the Altera world-wide web site at www.altera.com. You can also contact Altera through your local sales representative or any of the sources listed below.

Information Type	USA & Canada	All Other Locations
Technical support	www.altera.com/mysupport/	www.altera.com/mysupport/
	800-800-EPLD (3753) 7:00 a.m. to 5:00 p.m. Pacific Time	+1 408-544-8767 7:00 a.m. to 5:00 p.m. (GMT -8:00) Pacific Time
Product literature	www.altera.com	www.altera.com
Altera literature services	lit_req@altera.com	lit_req@altera.com
Non-technical customer service	800-767-3753	+ 1 408-544-7000 7:00 a.m. to 5:00 p.m. (GMT -8:00) Pacific Time
FTP site	ftp.altera.com	ftp.altera.com

Typographic Conventions

This document uses the typographic conventions shown below.

Visual Cue	Meaning
Bold Type with Initial Capital Letters	Command names, dialog box titles, checkbox options, and dialog box options are shown in bold, initial capital letters. Example: Save As dialog box.
bold type	External timing parameters, directory names, project names, disk drive names, filenames, filename extensions, and software utility names are shown in bold type. Examples: fMAX , qdesigns directory, d: drive, chiptrip.gdf file.
<i>Italic Type with Initial Capital Letters</i>	Document titles are shown in italic type with initial capital letters. Example: <i>AN 75: High-Speed Board Design</i> .
<i>Italic type</i>	Internal timing parameters and variables are shown in italic type. Examples: <i>tPIA</i> , <i>n + 1</i> . Variable names are enclosed in angle brackets (< >) and shown in italic type. Example: < <i>file name</i> >, < <i>project name</i> >.pdf file.
Initial Capital Letters	Keyboard keys and menu names are shown with initial capital letters. Examples: Delete key, the Options menu.
"Subheading Title"	References to sections within a document and titles of on-line help topics are shown in quotation marks. Example: "Typographic Conventions."
Courier type	Signal and port names are shown in lowercase Courier type. Examples: <code>data1</code> , <code>tdi</code> , <code>input</code> . Active-low signals are denoted by suffix <i>n</i> , e.g., <code>resetn</code> . Anything that must be typed exactly as it appears is shown in Courier type. For example: <code>c:\qdesigns\tutorial\chiptrip.gdf</code> . Also, sections of an actual file, such as a Report File, references to parts of files (e.g., the AHDL keyword <code>SUBDESIGN</code>), as well as logic function names (e.g., <code>TRI</code>) are shown in Courier.
1., 2., 3., and a., b., c., etc.	Numbered steps are used in a list of items when the sequence of the items is important, such as the steps listed in a procedure.
■ ● ● ●	Bullets are used in a list of items when the sequence of the items is not important.
✓	The checkmark indicates a procedure that consists of one step only.
	The hand points to information that requires special attention.
	The caution indicates required information that needs special consideration and understanding and should be read prior to starting or continuing with the procedure or process.
	The warning indicates information that should be read prior to starting or continuing the procedure or processes
↵	The angled arrow indicates you should press the Enter key.
	The feet direct you to more information on a particular topic.

The DSP Development Kit, Stratix® II Edition provides everything you need to develop complete system-on-a-programmable-chip (SOPC) solutions. This document describes how to install the software provided with the kit, how to connect the Stratix II DSP development board to your PC, and how to test the board.



This document covers the Stratix II EP2S60 DSP Development Kit and the Stratix II EP2S180 Professional DSP Kit. As necessary, the device will be noted as EP2S60/EP2S180.

Features

The DSP development kit includes:

- *The Stratix II EP2S60/EP2S180 DSP development board*—a prototyping platform that allows you to develop high-performance DSP designs. Key features of the board include a Stratix II EP2S60/EP2S180 device, high-speed analog-to-digital (A/D) and digital-to-analog (D/A) converters, and connectors for Texas Instruments and Analog Devices evaluation boards. Refer to the *Stratix II Development Board Reference Manual* for specific information about the components and interfaces included on the board.
- *DSP Builder*—DSP system design in Altera® devices requires both high-level algorithms and hardware description language (HDL) development tools. Altera's DSP Builder is a system-level DSP design tool that provides an interface between the MathWorks MATLAB/Simulink software and the Altera Quartus® II software. DSP Builder integrates these tools by combining the algorithm development, simulation, and verification capabilities of the MATLAB/Simulink system-level design tools with Altera's HDL synthesis, simulation, and place-and-route tools. DSP Builder shortens DSP design cycles by helping you create the hardware realization of a DSP design in an algorithm-friendly development environment, allowing system, algorithm, and hardware designers to share a common development platform. Refer to the *DSP Builder User Guide* for more information.



The DSP Builder software license included with the DSP Development Kit, Stratix II Edition is a perpetual license with free software upgrades for the first 12 months. After 12 months, you must purchase a renewal subscription for access to future software upgrades. For more information, refer to the Altera web site at www.altera.com.

- *Quartus II Software, Development Kit Edition (DKE)*—The Quartus II software provides a comprehensive environment for SOPC design. The Quartus II software integrates into nearly any design environment, with interfaces to industry-standard EDA tools.



The Quartus II DKE software license allows you to use the product for 12 months. After 12 months, you must upgrade to a Fixed PC or FloatNet subscription to continue using the software. For more information, refer to the Altera web site at www.altera.com.

- *IP MegaCore® Library version 6.0.1 CD-ROM*—This CD-ROM contains Altera IP MegaCore functions, including DSP MegaCore functions. You can evaluate the MegaCore functions using the OpenCore® Plus feature, which allows you to:
 - Simulate the behavior of a MegaCore function within your system
 - Verify the functionality of your design, as well as quickly and easily evaluate its size and speed
 - Generate time-limited device programming files for designs that include MegaCore functions which allow you to program a device and verify your design in hardware

You only need to purchase a license for a MegaCore function when you are completely satisfied with its functionality and performance, and want to take your design to production.



The OpenCore Plus hardware evaluation feature is an evaluation tool for prototyping only. You must purchase a license to use an Altera IP MegaCore function in production designs.

- *Nios® II Embedded Processor Windows Evaluation version 6.0.1 CD-ROM*—This CD-ROM contains the following:
 - *The Nios II CPU Component for SOPC Builder*—The CPU component provides three processor IP functions for the SOPC Builder hardware component library. The CPU component is

required by SOPC Builder to generate the hardware and system descriptions.

- *Nios II IDE*—An integrated platform for embedded software development including multiple run configurations and project management.
- *MathWorks MATLAB and Simulink CD-ROM Release 2006a (2006a)*—This CD-ROM contains third-party tools that are used in conjunction with DSP Builder as part of Altera’s DSP development flow. MATLAB is a high-level technical computing language environment for algorithm development, data visualization, data analysis, and numerical computation. Simulink provides an interactive graphical environment and a customizable set of block libraries that let you accurately design, simulate, implement, and test signal processing systems.



A 30-day license for MATLAB/Simulink is included as part of the DSP Development Kit, Stratix II Edition. To obtain the personal license password and for more information, please visit the MathWorks at: www.mathworks.com/products/connections/trials/altera.shtml.

- *DSP Development Kit, Stratix II Edition Version 6.0.1 CD-ROM*—This CD-ROM includes several reference designs and labs to help you get started building applications, as well as documentation, board schematics, the *Stratix II DSP Development Board Reference Manual*, and this user guide. Refer to “[Using the Reference Designs & Labs](#)” on page 2–11 for more information.

System Requirements

Before using the kit or installing the software, be sure to check the contents of the kit and inspect the board to verify that you received all of the items. If any of these items are missing, contact Altera before you proceed. You should also verify that the hardware and software in your computer meets the kit's requirements.

DSP Development Kit, Stratix II Edition Contents

The DSP Development Kit, Stratix® II Edition contains the following items:

- Stratix II DSP development board with an EP2S60/EP2S180 device
- *DSP Development Kit, Stratix II Edition Version 6.0.1 CD-ROM*
- *DSP Builder Version 6.0.1 CD-ROM*
- *The MathWorks MATLAB and Simulink CD-ROM Release 2006a (2006a)*
- *Quartus® II Development Software version 6.0.1 CD-ROM*
- *Nios® II Embedded Processor Windows Evaluation Edition version 6.0.1 CD-ROM*
- *IP MegaCore® Library version 6.0.1 CD-ROM*
- SLP-50 anti-aliasing filter from Mini-Circuits
- USB Blaster™ Download cable and USB cable
- Power supply and adapters for North America/ Japan, Europe, and the United Kingdom
- SMA cable
- RS-232 cable

Inspect the Board

Place the board on an anti-static surface and inspect it to ensure that it has not been damaged during shipment. Verify that all components are on the board and appear intact.



The Stratix II DSP development board can be damaged without proper anti-static handling.



Refer to the *Stratix II DSP Development Board Reference Manual* (available on the *DSP Development Kit, Stratix II Edition Version 6.0.1 CD-ROM*) for information on the board components and their locations.

Software Requirements

You should install the following software before you begin developing designs for the kit.

- The Quartus II software version 6.0 or higher. See “Installing the Quartus II Software & MegaCore Functions” on page 2–3.
- Internet Explorer 4.01 with Service Pack 2 or later to use Quartus II Help. You need a web browser to register the Quartus II software and request license files.
- The software on the *DSP Development Kit, Stratix II Edition Version 6.0.1 CD-ROM*. See “Installing the Reference Designs & Lab” on page 2–5.
- The MathWorks MATLAB and Simulink DSP system design and modeling tools provided on the *MathWorks MATLAB and Simulink CD-ROM Release 2006a (2006a)*. See “Installing The MathWorks MATLAB/Simulink CD-ROM” on page 2–3.

You need your network identification card (NIC) ID for licensing the Quartus II software.



Your NIC ID is a 12-digit hexadecimal number that identifies your computer to the computer that serves Quartus II licenses. Networked (or floating-node) licensing requires a NIC ID or server host ID. When obtaining a license file for network licensing, you should use the NIC ID from the PC that will issue the Quartus II licenses to distributed users over a network. You can find the NIC ID for your card by typing `ipconfig /all` at a command prompt. Your NIC ID is the number on the physical address line, minus the dashes.

Quartus II System Requirements

To use the DSP Development Kit, Stratix II Edition with the Quartus II software provided with the kit, your system must meet the Quartus II software minimum requirements. Refer to the *Quartus II Installation & Licensing Manual for PCs* for system requirements.

Software Installation

The instructions in this section explain how to install the following software:

- The Quartus II software, Development Kit Edition, including MegaCore functions from the *IP MegaCore® Library version 6.0.1 CD-ROM*
- MATLAB/Simulink software
- DSP Builder
- The Nios II embedded processor
- DSP reference designs and labs

Installing the Quartus II Software & MegaCore Functions

Refer to *Installing the Quartus II Software* in the *Quartus II Installation & Licensing Manual for PCs* for software installation instructions. After installing the software, request and install a license to enable it. Refer to “Set Up Licensing” on page 2-7 for more information.



During the installation of the Quartus II software, you are given the option to install the MegaCore IP Library. When prompted to do so, choose to install the MegaCore IP Library and follow the on-screen instructions.

Installing The MathWorks MATLAB/Simulink CD-ROM

To install MathWorks software on a PC running Windows NT/2000/XP, perform the following steps:

1. Before installing, make sure that you have your Personal License Password (PLP) available. To obtain the 30-day evaluation license and for more information, please visit the MathWorks at: www.mathworks.com/products/connections/trials/altera.shtml.
2. If it is running, close the MATLAB/Simulink software.
3. Insert the *MathWorks MATLAB and Simulink CD-ROM Release 2006a (2006a)*. The MathWorks Installer starts automatically, displaying the **Welcome to the MathWorks Installer** dialog box. Choose **Install** and click **Next**.
4. Enter your name, company name, and Personal License Password (PLP) in the **License Information** dialog box and click **Next**.
5. Review the software licensing agreement and, if you agree with the terms, select the Yes check box and click **Next**.

6. Select **Typical** or **Custom** installation and click **Next**.
7. Click **Install**.
8. Click **Finish**.

Install DSP Builder

To install DSP Builder on a PC running Windows NT/2000/XP, perform the following steps.



Before you install DSP Builder, Altera recommends that you install the MATLAB and Simulink software and the Quartus II software.

1. Close the following software applications if they are open:
 - The Quartus II software
 - The MAX+PLUS® II software
 - The LeonardoSpectrum™ synthesis tool
 - The Synplify software
 - The ModelSim simulator
 - The Precision RTL Synthesis software
2. When you insert the DSP Builder CD-ROM into your CD-ROM drive, the installation wizard begins automatically. If the wizard does not start, perform the following steps to manually launch installation:
 - a. Choose **Run** (Windows Start menu).
 - b. Type `<drive letter>:\dspbuilder-v6.0.1_sp1.exe`, where `<drive letter>` is your CD-ROM drive.
 - c. Click **OK**. The **DSPBuilder v6.0.1 - InstallShield Wizard** dialog box appears. Follow the on-line instructions to finish installation.



DSP Builder launches the LeonardoSpectrum, Synplify, Precision RTL Synthesis, or Quartus II software by retrieving the software's path information from your PC's registry file. If you have installed multiple versions of these software products, the registry may not point to the version you want to use with DSP Builder. In DSP Builder you can specify a path to use other than the registry setting for each of the tools.



Refer to *Specifying LeonardoSpectrum, Synplify & Quartus II Path Information for SignalCompiler* in the *DSP Builder User Guide* for information on specifying the paths.

When you have finished installing DSP Builder, view DSP Builder libraries in the MATLAB software by performing the following steps.

1. Start the MATLAB software.
2. At the MATLAB command prompt, change directory to the **DSP Builder\altlib** directory and type the following:

```
setup_dspbuilder ←
```

3. Expand the Simulink icon in the MATLAB **Launch Pad** window.
4. Double-click the **Library Browser** icon. The **Altera DSP Builder** folder appears in the **Simulink Library Browser** window.

Refer to the *DSP Builder User Guide* for information on the DSP Builder directory structure. The *DSP Builder User Guide* also includes a tutorial that describes how to create a design in Simulink and then convert it to VHDL for synthesis, Quartus II compilation, and RTL simulation.

Installing the Reference Designs & Lab

To install the reference designs and lab, insert the *DSP Development Kit, Stratix II Edition Version 6.0.1 CD-ROM* into your CD-ROM drive. The installation program runs automatically.

Figure 2–1 shows the DSP Development Kit, Stratix II Edition directory structure, where *<path>* is the DSP Development Kit, Stratix II Edition installation directory.

Figure 2-1. DSP Development Kit Directory Structure

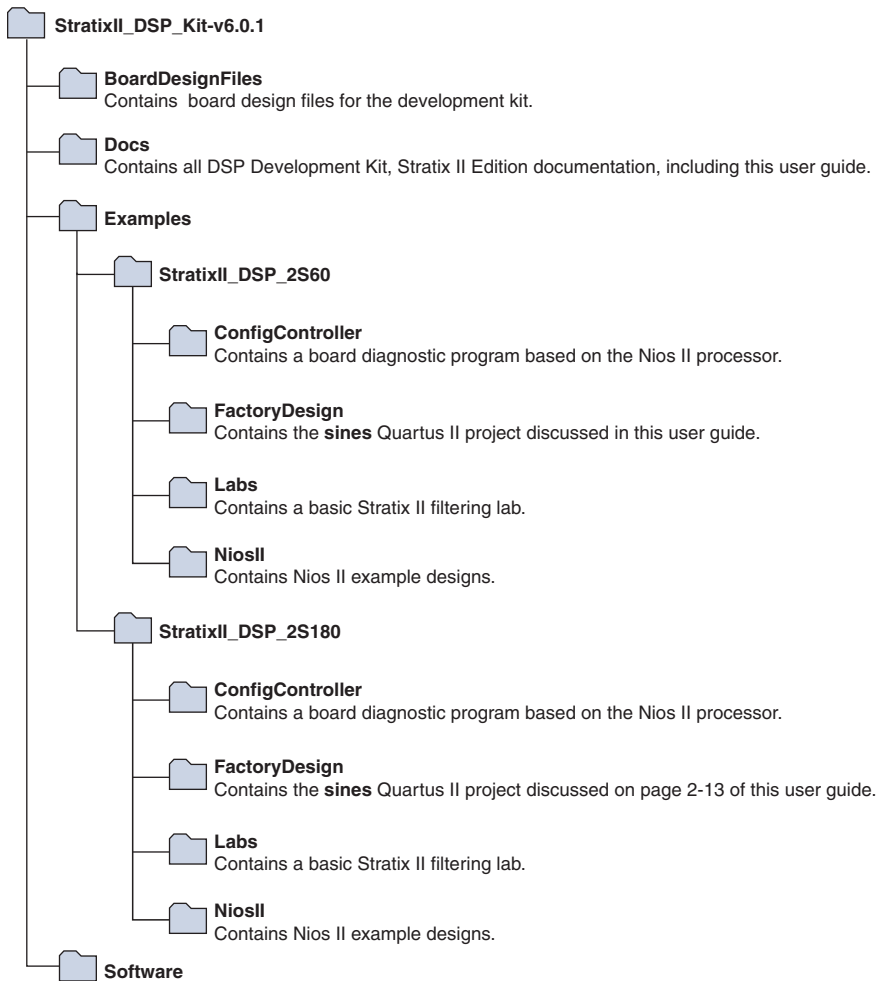

Installing the Nios II Embedded Processor

The Nios II CPU component and integrated development environment may be installed from the CD-ROM included in the kit.

1. Insert the *Nios® II Embedded Processor Windows version 6.0.1 CD-ROM*. If the install program does not automatically start, browse to your CD-ROM drive and double-click on the program **launcher.exe**.
2. Select which components to install. It is recommended that you install the default check box options.
3. Follow the on-screen instructions to select the installation directory and program group.
4. When installation completes, copy the board components for the Stratix II EP2S60/EP2S180 DSP development boards into the **Nios** directory so that they will be available in SOPC builder as board components. Perform the following steps to copy the components:
 - a. Browse to *<drive letter>*:\altera\kits**StratixII_DSP_DK_v6.0.1\Components**, where *<drive letter>* is the drive on which you have installed your Altera software.
 - b. Shift-click to select the **altera_dsp_dev_board_stratix_2s60** and **altera_dsp_dev_board_stratix_2s180** directories.
 - c. Press Ctrl + C to copy the directories.
 - d. Browse to the *<drive letter>*:\altera\kits directory.
 - e. Press Ctrl + V to paste the directories.

Set Up Licensing

Before using the Quartus II software and DSP Builder, you must request a license file from the Altera web site at www.altera.com/licensing and install it on your PC. When you request a license file, Altera e-mails you a **license.dat** file that enables the software.

To obtain a license, perform the following steps.

1. Point your web browser to the Altera web site at www.altera.com/licensing.
2. Click **DSP Development Kit, Stratix II Edition**.

3. Follow the on-line instructions to request your license. A license file is e-mailed to you.



Before installing your license, close the following software if it is running on your PC:

- The Quartus II software
 - The MAX+PLUS® II software
 - The LeonardoSpectrum synthesis tool
 - The Synplify software
 - The ModelSim simulator
 - The Precision RTL Synthesis Software
4. To install your license, refer to “Specifying the License File” in the *Quartus II Installation & Licensing Manual for PCs*, which is included with the kit.

Connect the Cables to the Board & PC

The instructions in this section explain how to set up the following hardware:

- USB Blaster cable
- Power supply cable
- SMA cable
- SLP-50 anti-aliasing filter

USB Blaster Cable

Connect the USB Blaster cable’s 10-pin female plug to the Stratix II device JTAG header on the Stratix II DSP development board (J21) and connect the other end to your PC to configure the Stratix II device directly using an SRAM Object File (.sof). See [Figure 2–2](#). The reference designs and lab provided with this kit include SOFs for configuring the Stratix II device directly.

Figure 2–2. Connecting the USB Blaster Cable to J21

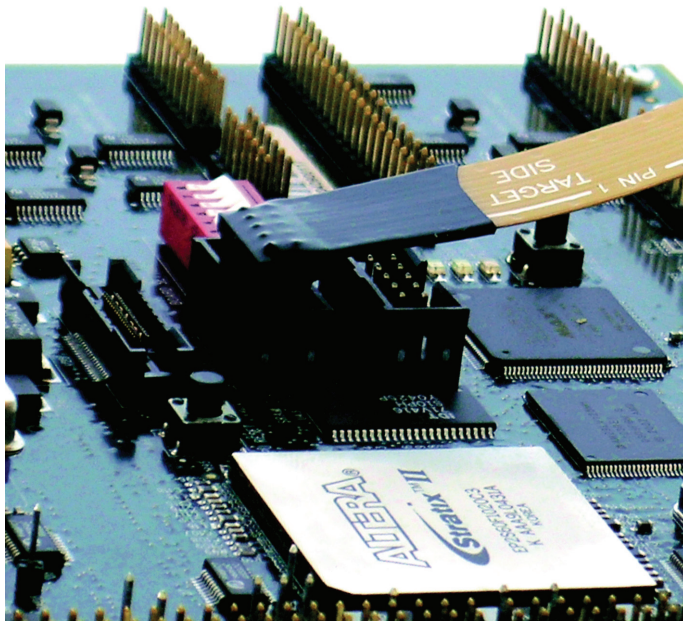

Refer to the *USB Blaster Download Cable User Guide* for information on how to install the USB Blaster download cable driver included with the Quartus II software.

SMA Cable

The ends of the SMA cable can be connected to any of the four connectors on the Stratix II DSP development board: the digital-to-analog converter connectors, DAC A OUT and DAC B OUT, or the analog-to-digital converter connectors, ADC A IN and ADC B IN. [Figure 2–3](#) shows the cable and the SLP-50 anti-aliasing filter installed as required in [“Performing the A/D & D/A Converter Performance Test”](#) on page 2–15.

Figure 2–3. SMA Cable & SLP-50 Filter Installed to Connect DAC B OUT with ADC A IN

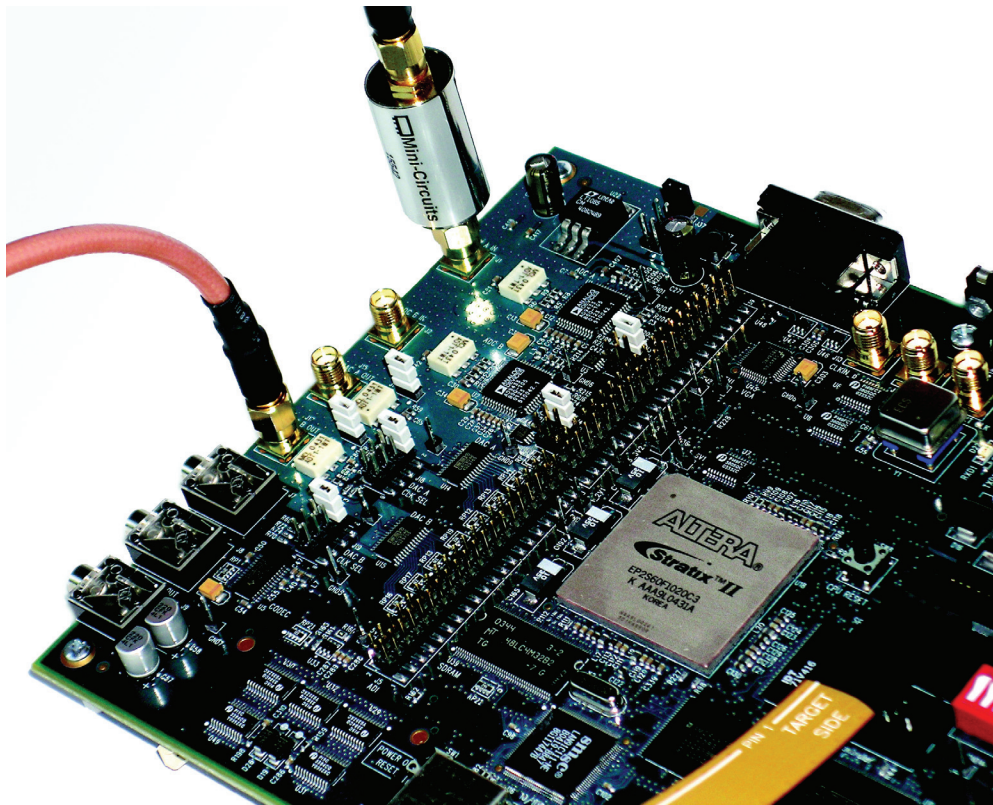

SLP-50 Anti-Aliasing Filter

The SLP-50 anti-aliasing filter from Mini-Circuits provides a 55-MHz cutoff frequency. To use the anti-aliasing filter, connect the filter to the SMA cable. You can perform an external loopback from one of the D/A converters to one of the A/D converters by connecting the output of the one to the input of the other, using the filter and cable assembly. If the cutoff frequency must be lower than 55 MHz, you can use other filters.

Power Supply Cable

Connect the power cable to the board as shown in [Figure 2–4](#) and plug the other end into a power outlet.

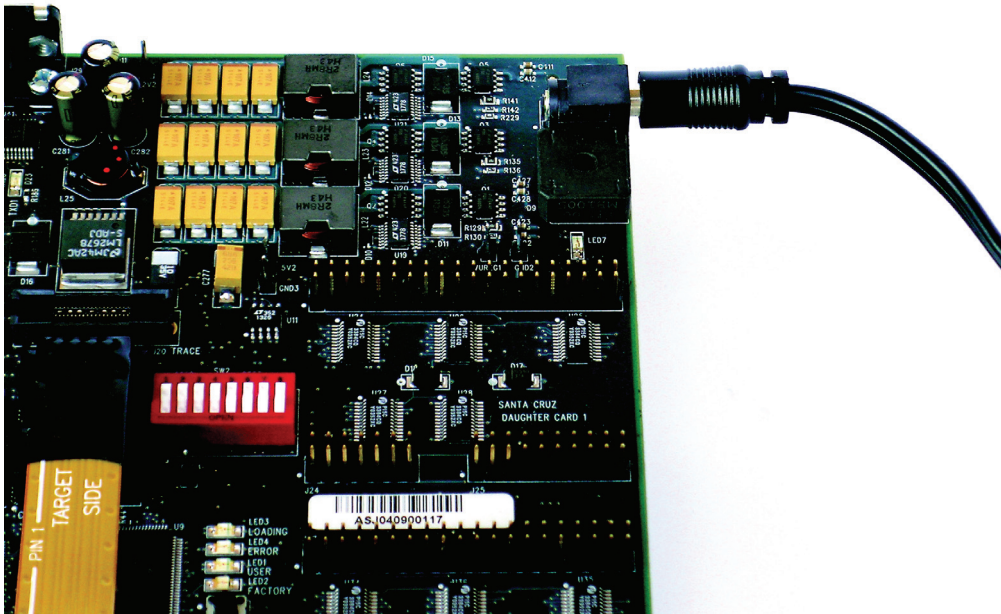
Figure 2–4. Connected Power Cable

After the board powers up, the on-board flash memory, which ships pre-programmed with the factory design, automatically configures the Stratix II device. The CONF_DONE LED turns on, signifying that the Stratix II device is configured. For more information on the factory design, refer to [“Testing the Board Using the Factory Design”](#) on page 2–14.



If the board does not power up after connecting the power cable, make sure that SW9, located near the Ethernet connector (RJ1) is in the “ON” position.

Using the Reference Designs & Labs

Altera provides several reference designs and a lab with the DSP Development Kit, Stratix II Edition to help you get started building applications. The included reference designs and lab are described in *AN 362: Stratix II Filtering Reference Design Lab*.

This document contains background information and lab exercises. The design’s `doc` directory contains the application note describing the design.

Unused Pins In Your Designs

When compiling your own designs, Altera recommends that you set all unused pins to act as tri-stated inputs.



The following procedure is not necessary for the reference designs and lab included with the DSP Development Kit, Stratix II Edition because the designs already have their unused pins set as tri-stated inputs.

To change this setting in the Quartus II software, perform the following steps:

1. Choose **Device** (Assignments menu).
2. On the **Device** page of the **Settings** dialog box, click **Device and Pin Options**.
3. In the **Device and Pin Options** dialog box, click the **Unused Pins** tab.
4. Under **Reserve all unused pins**, select **As Inputs, tri-stated** (Figure 2-5).

Figure 2–5. Device & Pin Options Dialog Box

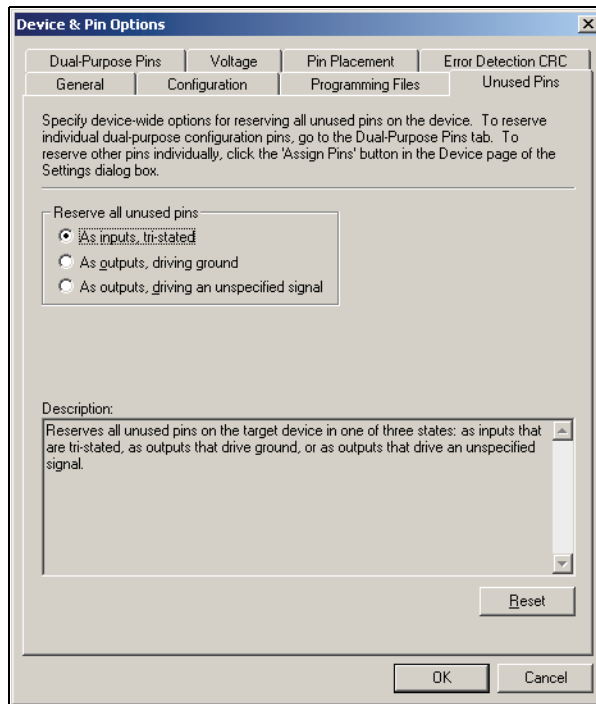

5. Click **OK** twice.



The Quartus II software default settings configure unused pins as outputs driving ground. Board components may be damaged by having GND signals driven onto pins that drive V_{CC} .



Refer to the *Stratix II DSP Development Board Reference Manual* for more information on how to configure the Stratix II device on the board. Refer to the *Configuring Stratix II devices* chapter of the *Stratix II Handbook* for more information on configuring Stratix II devices.

Testing the Board Using the Factory Design

When you apply power to the board, the Stratix II device is programmed with the factory design stored in flash memory. After the device is programmed, LEDs D5 through D8 behave as a binary counter that counts down to zero. This is a power-up indication that the board is functional and the device was successfully programmed with the factory design.



If you do not see the LEDs behaving as described above shortly after power is applied to the board, disconnect power. Make sure that SW9 is switched to “ON” and switch 4 on SW2 is in the “OPEN” position, then apply power to the board again.

In the factory design, two sine waves are generated by two blocks of IP generated by the Altera NCO Compiler. One of these oscillators is running at 10 times the frequency of the other, but both of them have the same amplitude, covering 13 bits of dynamic range. The two sine waves output from these blocks are added together and the output is converted from a 2’s complement representation into unsigned integer format. This combined sine wave signal of 14-bits dynamic range is sent to a 14-bit D/A converter. The analog output of a D/A converter is connected, via the included SMA cable, with the analog input of a 12-bit A/D converter. The A/D converter’s digital output is looped back to the Stratix II device. The design converts this loopback input from 2’s complement format to unsigned integer format. The converted loopback data is captured by an instance of the SignalTap® II logic analyzer in the design for display and analysis. Figure 2–6 shows a high-level view of the factory design and how it interacts with the D/A and A/D converters on the board.

Figure 2–6. Factory Design Functional Block Diagram

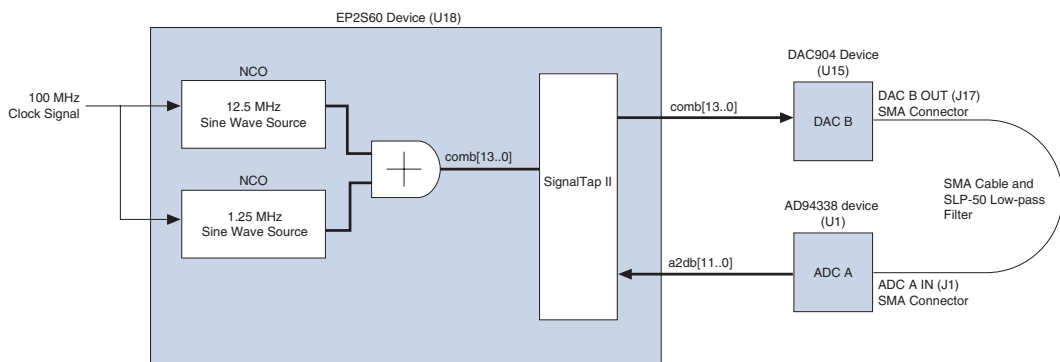



The design files for the factory design are installed from the *DSP Development Kit, Stratix II Edition Version 6.0.1 CD-ROM* to the `<path>\StratixII_DSP_Kit-v6.0.1\Examples\<board name>\FactoryDesign` directory, where `<path>` is the DSP Development Kit, Stratix II Edition installation directory.

Testing LEDs & Pushbutton Switches

In the factory design, switches SW4 to SW7 are connected via inverters to LEDs D1 to D4 respectively. Whenever a switch is pushed down, the corresponding LED lights up. Test this functionality on the board.

Performing the A/D & D/A Converter Performance Test

To test the A/D and D/A converter performance using the factory design, perform the following steps:

1. Configure the board.
2. Collect data from the design using the SignalTap II logic analyzer.
3. Analyze the data in the MATLAB software.

These steps are described in detail in the following sections.

Configuring the Board

To configure the board, perform the following steps:

1. Connect the SLP-50 filter (low-pass filter) to one end of the SMA cable.
2. Use the cable-filter assembly to connect DAC B OUT with ADC A IN.
3. Add the correct jumpers for the clocks.
 - a. For the ADC A clock, add a jumper to J3 between pins 1 and 2.
 - b. For the DAC B clock, add a jumper to J19 between pins 1 and 2.

Figure 2–7 shows the locations of J3 and J19.

Figure 2-7. Locations of J3 & J19

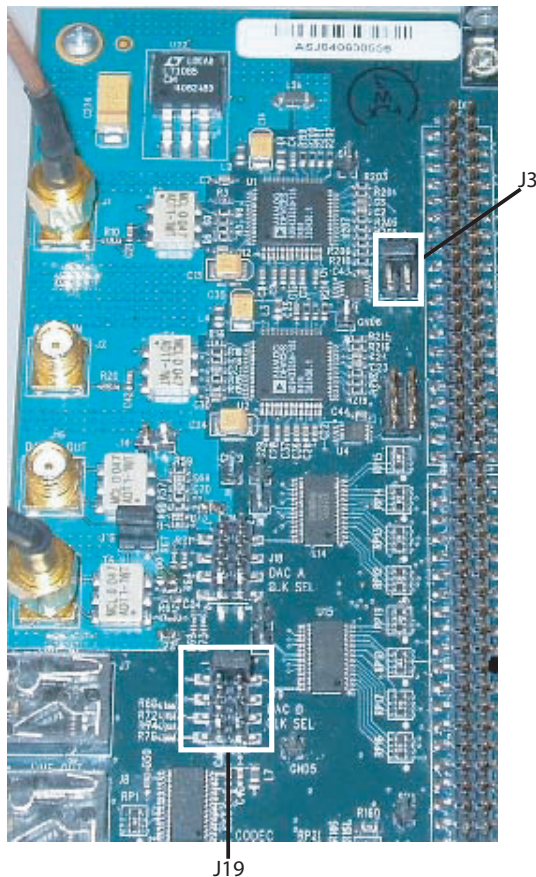

4. Start the Quartus II software.
5. In the Quartus II software, open the **sines** project at `<path>\StratixII_DSP_Kit-v6.0.1\Examples\<board name>\FactoryDesign\sines.qpf` where `<path>` is the directory where the DSP Development Kit, Stratix II Edition Version 6.0.1 CD-ROM is installed.
6. The Signal Tap II file (**.stp**) provided with the design, **sines.stp**, is opened automatically when you open the **sines** project. To bring it to the front, choose **sines.stp** (Window menu). Figure 2-8 shows **sines.stp** displayed in the SignalTap II logic analyzer.

Figure 2–8. Sines.stp Displayed in the SignalTap II Logic Analyzer

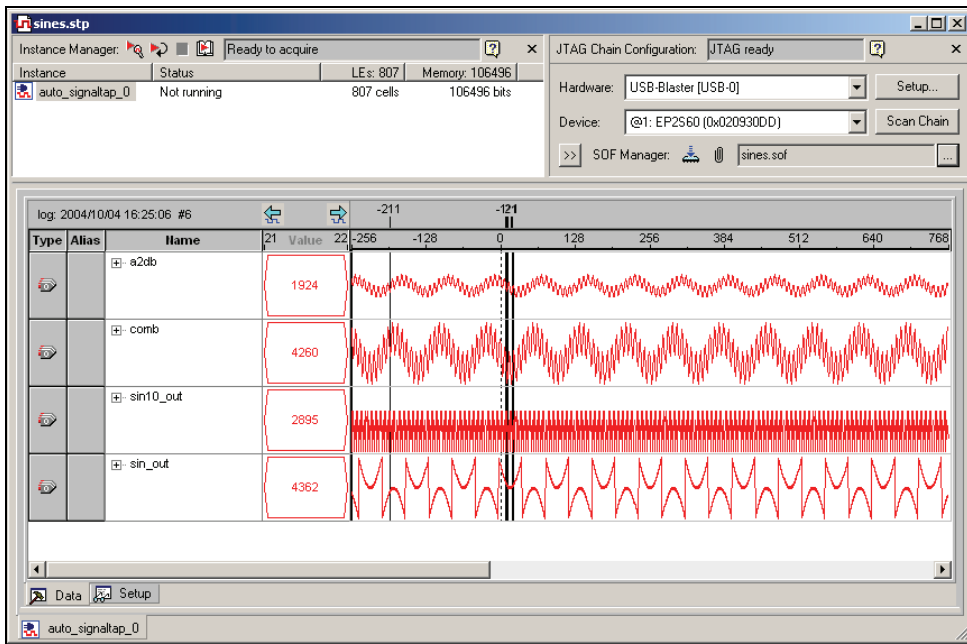

If you modify and recompile the design, specify your new SOF and click **Program Device** in the SignalTap II window to reprogram the device with your SOF file.

Collecting Data Using the SignalTap II Logic Analyzer

To collect data from the design for analysis, perform the following steps.

1. In the Instance Manager section of the SignalTap II window, click **Run Analysis** and observe the following:
 - a. Observe the D/A converter input on `comb [13..0]`. It shows a combination of two sine waves.
 - b. Observe the A/D converter output on `a2db [11..0]`. It shows an attenuated combination of two sine waves.



The A/D converter output is attenuated because the bit resolution is reduced from 14 bits to 12 bits. Analog circuitry on the board also causes some additional attenuation.

2. Ensure that all four busses are expanded in the SignalTap II logic analyzer.
3. Choose **Create SignalTap II List File** (File > Create / Update menu) The Quartus II software generates the file **sines_auto_signaltap_0.txt** in the project directory.

Analyzing the Data in the MATLAB Software

To analyze the a2db data from **sines_auto_signaltap_0.txt** in MATLAB, perform the following steps:

1. Start the MATLAB software.
2. In the MATLAB software, change the directory to the `<path>\StratixII_DSP_Kit-v6.0.1\Examples\<board name>\FactoryDesign\` directory, where `<path>` is the directory in which the *DSP Development Kit, Stratix II Edition Version 6.0.1 CD-ROM* is installed.
3. At the MATLAB command prompt, type the following:

```
nstp_plot('sines_auto_signaltap_0.txt') ←
```

The MATLAB software displays a normalized plot of DAC B input similar to [Figure 2-9](#).

Figure 2–9. Normalized Spectral Plot of 14-Bit DAC B Input Data

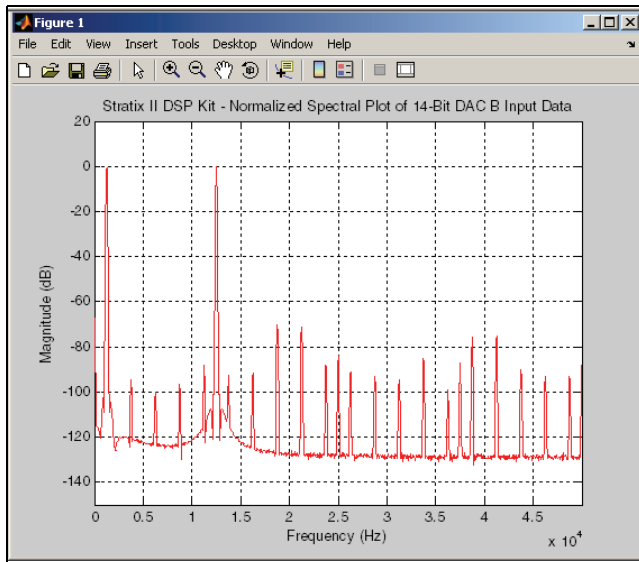

The plotted graph noise floor average is below 65 db. A normalized FFT plot of ADC A output is shown in [Figure 2–10](#).

Figure 2–10. Normalized Spectral Plot of The 12-bit ADC A Output Data

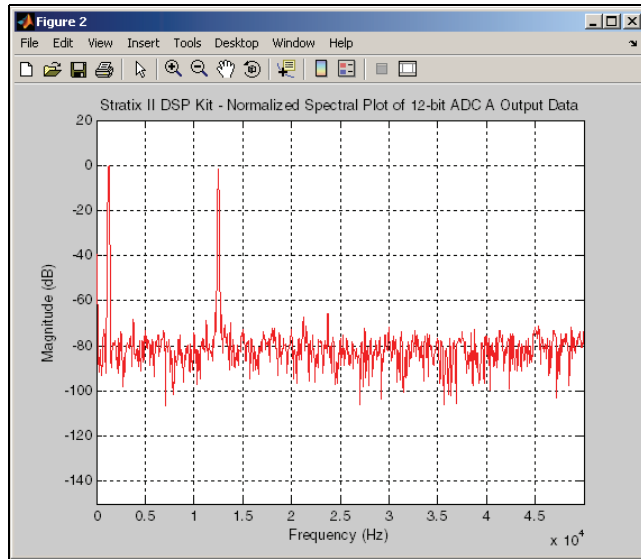

Conclusion

You have successfully completed the Getting Started steps for the DSP Development Kit, Stratix II Edition. You are now ready to begin building custom designs or explore the reference designs included in the *DSP Development Kit, Stratix II Edition Version 6.0.1 CD-ROM*.

