

USER'S  
HANDBOOK

4700

**datron**

INSTRUMENTS

**AUTOCAL MULTIFUNCTION  
CALIBRATOR**



**DANGER**  
**HIGH VOLTAGE**



**THIS INSTRUMENT IS CAPABLE  
OF DELIVERING  
A LETHAL ELECTRIC SHOCK!**



FRONT or REAR  
terminals carry the  
Full Output Voltage.

**THIS CAN KILL!**



Guard terminal is  
sensitive to over-  
voltage

**It can damage  
your instrument!**

Unless **you** are **sure** that  
it is **safe** to do so,  
**DO NOT TOUCH** the  
**I+ I- Hi or Lo leads**  
and **terminals**

**DANGER**

# CONTENTS

	Page
<b>SECTION 1 THE DATRON 4700 AUTOCAL MULTIFUNCTION CALIBRATOR</b>	1-1
Introduction	1-1
Standard and Optional Facilities	1-2
<b>SAFETY</b>	1-3
Optional Facilities	1-3
Accessories	1-3
Additional Documentation	1-3
Principles of Operation	1-4
<b>SECTION 2 INSTALLATION</b>	2-1
Unpacking and Inspection	2-1
Preparation for Operation	2-1
Bench Mounting	2-2
Rack Mounting	2-2
Connectors and Pin Designations	2-3
<b>SECTION 3 OPERATING CONTROLS</b>	3-1
Front Panel	3-1
Front Panel Keys	3-1
Power Switch	3-1
OUTPUT Switching	3-2
FUNCTION Keys	3-3
OUTPUT RANGE Keys	3-3
OUTPUT Display and $\uparrow$ / $\downarrow$ Keys	3-4
Frequency	3-5
MODE Selection Keys	3-8
I+, I-, Hi, Lo, Guard and Ground Terminals	3-9
Rear Panel	3-11
<b>SECTION 4 USING THE DATRON 4700</b>	4-1
Preliminaries	4-1
Limiting Characteristics	4-1
<b>SAFETY</b>	4-1
Interconnections	4-1
Typical Lead Connections	4-4
General Sequence of Operations	4-6
Display Messages	4-6
Operating Routines	4-7
DC Voltage Outputs	4-7
AC Voltage Outputs	4-7
Option 20 Currents and Resistance	4-9
DC Current	4-9
AC Current	4-9
Resistance	4-9
Additional Facilities	4-10
Frequency Store	4-10
'Spec' Mode	4-10
'Error' and 'Offset' Modes	4-12
Combining Offset and Error Modes	4-16
Test Key	4-16
Test Sequence	4-17
Warnings and Messages	4-20

<b>SECTION 5 SYSTEMS APPLICATION VIA THE IEEE 488 INTERFACE</b>	5-1
Introduction	5-1
Interface Capability	5-1
Bus Addresses	5-2
Interconnections	5-2
Typical System	5-3
Using the 4700 in a System	5-4
Programming Instructions	5-5
Programming of Operational Functions	5-8
Programming of Bus Transmissions	5-10
Activation of Commands	5-14
Multiple Commands	5-14
Operational Sequence Guidelines	5-15
<b>SECTION 6 SPECIFICATIONS</b>	6-1
General	6-1
DC Voltage	6-2
AC Voltage	6-4
Voltage/Frequency Constraints	6-6
Capacitive Loading Constraints	6-7
DC Current	6-8
AC Current	6-10
Resistance	6-12
<b>SECTION 7 SPECIFICATION VERIFICATION</b>	7-1
Introduction	7-1
DC Specification Verification	7-1
Equipment Requirements	7-2
Notes on the Use of the Null Detector	7-2
Specification Verification Report Sheet	7-3
Verification Procedures	7-3
4700 DC Voltage Performance	7-4
4700 DC Current Performance	7-7
4700 Resistance Performance	7-5
Model 4700 Verification Report Sheet. RS1	7-9
AC Specification Verification	7-9
Choice of Verification Method	7-9
Parameters to be Verified	7-9
Summary of Equipment Requirements	7-10
Summary of Verification Procedures	7-11
Specification Verification Procedures	7-12
AC Voltage Verification Procedure	7-13
Millivolts (LF) Verification Procedure	7-14
Millivolts (HF) Verification Procedure	7-16
AC Current Verification Procedure	7-17
Model 4700 Verification Report Sheet. RS2	
<b>APPENDICES TO SECTION 7:</b>	7-19
1. Verification Procedures For Users with Fixed DC Voltage Standards	7-25
2. Alternative Millivolt Verification Procedure	7-27
3. Alternative AC Current Verification Procedure using Calibrated Standard AC Shunts	7-29
4. Total Tolerance Limit Calculations	7-31
5. Uncertainty and Traceability	7-33
6. General Procedural Information	7-35
7. Harmonic Distortion Measurement	

<b>SECTION 8 ROUTINE AUTO CALIBRATION</b>	8-1
The 4700 Autocal Feature	8-1
DC Calibration	8-2
Autocal Availability	8-3
Zero Calibration	8-3
Equipment Required for DC Calibration	8-3
Interconnections	8-4
DC Calibration Sequence	8-4
4700 DC Voltage Calibration	8-5
4700 DC Current Calibration	8-8
4700 Resistance Calibration	8-10
AC Calibration	8-12
AC Calibration Sequence	8-13
4700 AC Voltage Calibration (1V-1000V)	8-15
4700 AC Millivolts (LF) Calibration (1mV-100mV)	8-17
4700 AC Millivolts (HF) Calibration (1mV-100mV)	8-18
4700 AC Current Calibration (1mA-1A)	8-20
 <b>APPENDIX TO SECTION 8:</b>	 8-21
4700 AC Current Calibration (100 $\mu$ A - 1A)	

Inside Rear Cover

**DATRON SALES AND SERVICE REPRESENTATIVES WORLDWIDE**

**Note to Readers**

This handbook has been designed for you to get the best use from your 4700. The sections are put together in a sequence flowing logically from one subject to another, so that understanding increases as the text is read naturally from front to rear. Here is an alternative (explanatory!) version of the Section Titles:

- Sect 1. Introduction and a brief account of the internal design.
- Sect 2. Physical connections and mounting — getting it installed.
- Sect 3. A brief scan of the available controls — where they are and what they do.
- Sect 4. The correct procedures for making the 4700 perform **for you**.
- Sect 5. How your 4700 can operate within an IEEE 488 system — the device dependent codes you will need to use.
- Sect 6. Specifications — what accuracy you can expect to get from your instrument.
- Sect 7. Verification that your 4700 matches the high specification it had when it left the factory.
- Sect 8. How to restore your 4700 to its original specification after it has suffered the ravages of time and temperature.

We are confident that your 4700 will give you many years of accurate and reliable service, and hope that you will use this handbook to obtain maximum benefit from its many facilities.

# SECTION 1

## THE DATRON 4700

### AUTOCAL MULTIFUNCTION CALIBRATOR

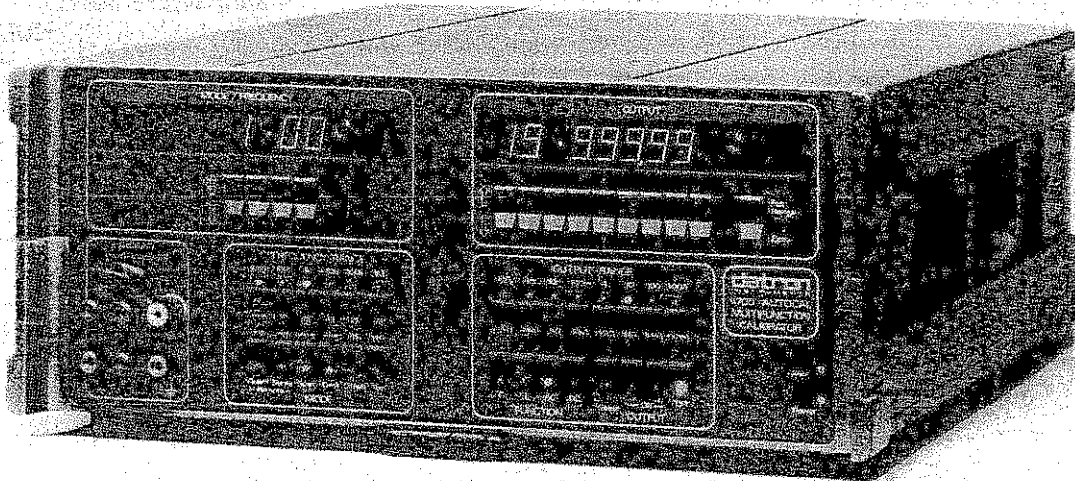

General View of Datron 4700 Autocal Multifunction Calibrator

## Introduction

The Datron 4700 Autocal Multifunction Calibrator is a high-precision calibrator which features exceptionally high stability and full systems capability. It is characterized by a wide-range coverage of DC Voltage, AC Voltage, DC Current, AC Current and Resistance functions in a single unit.

The basic instrument includes both DC Voltage and AC Voltage calibration sources up to the 100V range (200V maximum output).

Option 10 (factory-fitted) extends both DC Voltage and AC Voltage functions up to the 1000V range (1100V maximum output).

Option 20 (field or factory-fitted) adds calibration sources of DC Current, AC Current and Resistance.

The 4700 incorporates a reference module containing precision temperature-compensation elements, maintaining a high accuracy specification over the ambient temperature range of  $23^{\circ}\text{C} \pm 10^{\circ}\text{C}$ . A high level of stability is achieved by use of super-selected reference components and ultra-stable gain-defining resistors. The 'Autocal' feature ensures that its 24-hour specifications are usable; not merely figures of merit.

The 4700 uses a microprocessor for control management, simplifying its use in complex manual operations, such as calibration of high-quality digital multimeters. The IEEE 488 interface provides a comprehensive remote programming capability, allowing programmed calibration of the 4700 itself.

## Standard and Optional Facilities

### DC Voltage Ranges

The basic instrument provides DC Voltage calibration facilities in seven decade ranges from  $\pm 100\mu\text{V}$  to  $\pm 100\text{V}$ . By fitting Option 10, an eighth decade range to  $\pm 1000\text{V}$  is available. 100% overrange is incorporated, except on the optional  $\pm 1000\text{V}$  range, when the output is limited to 1100V.

### Resolution and Accuracy

The maximum resolution is  $7\frac{1}{2}$  digits with a unique facility for displaying the specified accuracy of any output voltage. The 4700 specification is in Section 6.

---

### AC Voltage Ranges

The basic instrument provides AC Voltage calibration facilities in six decade ranges from 1mV to 100V. By fitting Option 10, a seventh decade range to 1000V is available. 100% overrange is incorporated, except on the optional 1000V range (see page 3-6), when the output is limited to 1100V.

### Resolution and Accuracy

The maximum resolution is  $6\frac{1}{2}$  digits with a unique facility for displaying the specified accuracy of any output voltage. The 4700 specification is in Section 6.

---

### DC Current Ranges

By fitting Option 20, the instrument can be used to calibrate DC Current in five decade ranges from  $100\mu\text{A}$  to 1A.

### Resolution and Accuracy

The maximum resolution is  $6\frac{1}{2}$  digits with a unique facility for displaying the specified accuracy of output current. The 4700 specification is in Section 6.

---

### AC Current Ranges

By fitting Option 20, the instrument can be used to calibrate AC Current in five decade ranges from  $100\mu\text{A}$  to 1A.

### Resolution and Accuracy

The maximum resolution is  $6\frac{1}{2}$  digits with a unique facility for displaying the specified accuracy of output current. The 4700 specification is in Section 6.

---

### Resistance

By fitting Option 20, the instrument can be used to calibrate resistance in eight decade ranges from 10ohm to 100Mohm.

### Resolution and Accuracy

The maximum resolution is  $7\frac{1}{2}$  digits with a unique facility for displaying the specified accuracy of any output resistance. The 4700 specification is in Section 6.

---

## Frequency

The output frequency of the 4700 extends from 10Hz to 1MHz in five overlapping decade ranges, at a resolution of 1% of nominal Frequency Range. Any five frequency values within the range of the instrument can be stored in volatile memory.

## Output Deviation

A user may deviate the output voltage from the output display value by introducing a gain 'Error' within the general range  $\pm 10\%$ . Additionally, for DC functions, the output may be 'offset' by up to  $\pm 2\%$  of the range in use, or  $200\mu\text{V}$ , whichever is greater.

## Autocal

All Datron AUTOCAL instruments are designed to make the removal of the covers for calibration unnecessary, as full routine calibration of all ranges and functions can be carried out from the front panel or over the IEEE 488 bus.

Accidental or unauthorized use of the calibration routine is prevented by a key-operated switch on the instrument rear panel. The procedure for calibrating this instrument is contained in Section 8.

## Remote Sense

The specified output voltage may be sensed at the load, using 4-wire connections. Remote or Local Sense is selectable from the front panel.

## Remote Guard

This facility allows the instrument's internal guard shields to be externally connected.

## Self-test

On power-up, the internal calibration memory is automatically checked. At any time when the output is off and not under remote control, a user may conduct a sequenced test of the displays, keyboard, safety circuitry and Reset function.

## Message Readout

Messages to the user are presented on the MODE display:

The two main groups are:

### Fail

An internal fault condition has been detected.

### Error

A user has selected a task which is outside the instrument's capability.

## Systems Use

The instrument can form part of a system by means of the IEEE 488 standard digital interface. The method of connecting to the system controller and the command codes are described in Section 5.

## SAFETY

For protection of the user, safety trip circuits are incorporated to switch the OUTPUT OFF, in the event of instrument failures which might generate dangerous output voltages.

**UNDER NO CIRCUMSTANCES SHOULD USERS TOUCH ANY OF THE OUTPUT, SENSE OR GUARD TERMINALS UNLESS THEY ARE FIRST SATISFIED THAT NO DANGEROUS VOLTAGE IS PRESENT.**

## Optional Facilities

The available options for the 4700 are as follows:

Option 10: 1000V ranges (DCV and ACV)

Option 20: DC Current, AC Current and Resistance functions

Option 42: Rear output terminals (as a factory-fitted alternative to front panel terminals).

NB: The rear output option is not recommended for best performance in calibrating high bandwidth, low level instruments.

Option 90: Rack-mounting kit.

## Accessories

The instrument is supplied with the following accessories:

Description	Part Number
Power Cable	920012
Set of Calibration keys	700068
User's Handbook	850052
Calibration and Servicing Handbook	
(2 volumes)	(Volume 1) 850057
	(Volume 2) 850059

In addition the following accessories are available for use with the 4700 instrument:

Description	Part Number
RMK Rack-mounting kit (Option 90)	440094
Special Lead Kit	440070

## Additional Documentation

The Calibration and Servicing Handbook contains information required to adjust and service the 4700 instrument. It contains detailed descriptions of the circuits, trouble-shooting and calibration procedures, parts lists, layout drawings and circuit diagrams.



# Principles of Operation

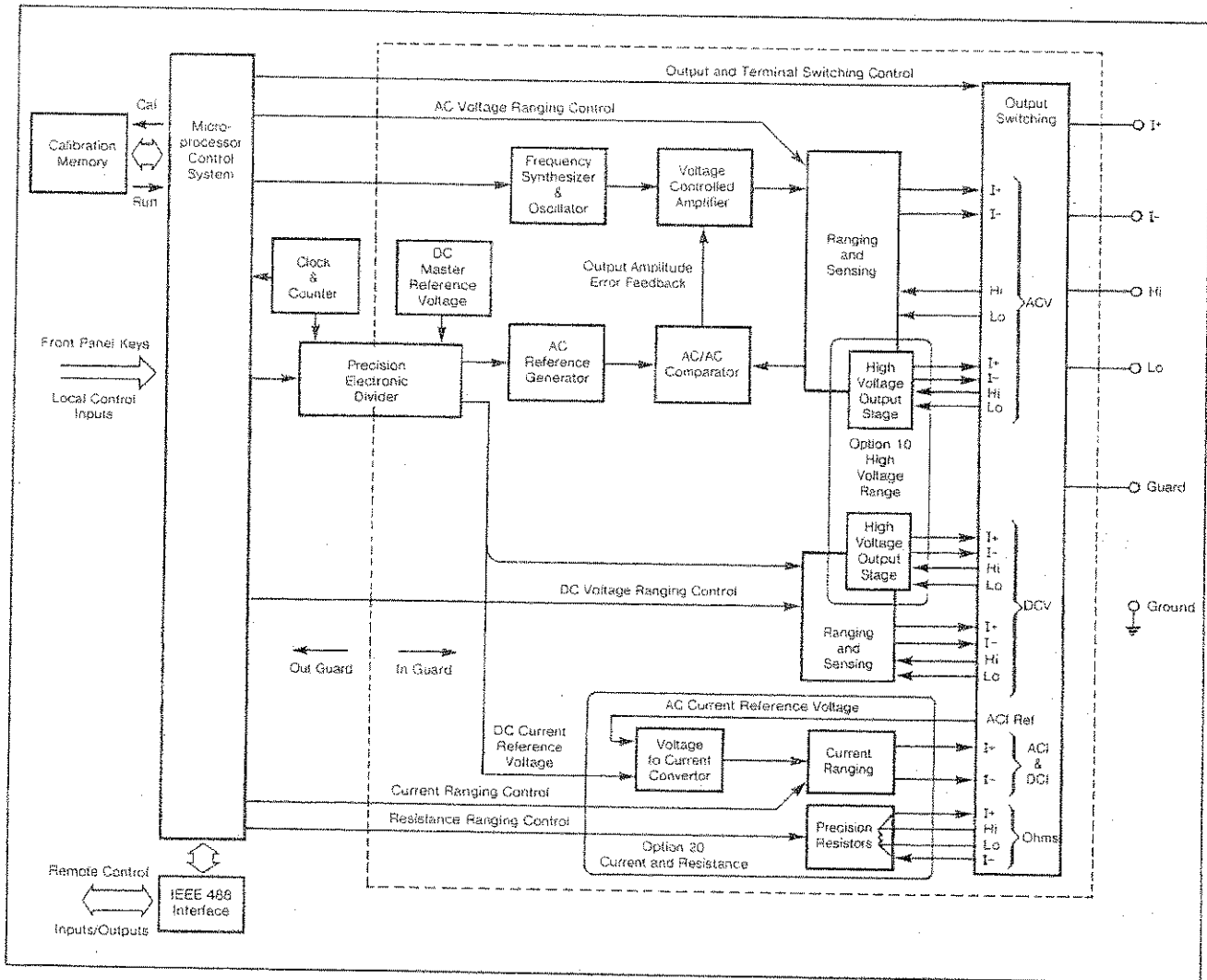

Simplified Functional Diagram . This shows the division and flow of functions within the 4700.

## Inputs

The 6802 microprocessor controls the output in response to three main inputs:

- i) Front panel keys.
- ii) IEEE 488 bus messages in 'Remote' operation.
- iii) Corrections placed in non-volatile memory during 'Autocalibration'. These modify the values which control the output.

After processing, the computing system changes the output of the instrument to respond to the input instructions.

## Reference Voltages

A 20V DC 'Master' Voltage Reference establishes the fundamental accuracy of the instrument. From this 20V, a precision electronic divider derives an

adjustable 'Working' reference voltage between 0V and 20V, whose value depends on digital inputs from front panel keys and calibration memory.

## Precision Electronic Divider

In the out-guard section the selected output value, including calibration corrections, is set into a digital comparator as a 25-bit number. This is counted out by a crystal controlled binary counter, resulting in a 125Hz square wave whose mark : period ratio accurately represents the output value selection. When transferred into guard, it chops the Master Reference voltage. A 7-pole active low-pass filter integrates the chopped reference, to generate the ripple-free DC Working Reference Voltage.

## DC Voltage Output

The working reference for DC Voltage Output is

a stable DC voltage, accurately variable at high resolution between 0 and + 20V.

**DC Voltage Ranging**  
**Low Voltage Ranges (100 $\mu$ V — 10V FR).** The basic range of the 4700 is  $\pm$  10V Full Range ( $\pm$  19.999999V Full Scale), derived directly from the working reference. The 1V and 100mV ranges are achieved by attenuation:

The 100mV range attenuator is also used for 10mV, 1mV and 100 $\mu$ V ranges, and the digital input to the precision divider is scaled to provide the correct working reference values:

Range	Working reference values
10mV	-2V - + 2V
1mV	-200mV - + 200mV
100 $\mu$ V	-20mV - + 20mV

**High Voltage Ranges (100V and 1000V)**  
The 100V range is a direct amplification of the working reference. The optional 1000V range employs step-up AC transformation.

**Output Switching.** In addition to switching between functions, the output switching circuits isolate terminals on **OUTPUT OFF**. Remote/Local Sense and Guard switching is incorporated.

**AC Voltage Output**  
The working reference for AC Voltage Output is a stable DC voltage, accurately variable at high resolution between + 0.1V and + 2V DC.

**AC Reference Generator**  
The higher accuracy of AC/AC comparison (over AC/DC) is exploited by converting the DC Working Reference into a stepped waveform whose characteristics match those of a sine wave. The amplitude of this 'Quasi-sinewave' is precisely controlled by the DC Working Reference value.

#### Sinewave Source

**Frequency Synthesizer**  
From the frequency value set into the MODE/FREQUENCY display, the processor controls the synthesizer using an encoded 9-bit command. The synthesizer translates the command into a pulse train at a crystal-derived frequency between 240kHz and 4MHz, to be divided down for use as phase-reference for the Quadrature Oscillator.

N.B. If required, the Frequency Synthesizer, can be locked to a customer's 1MHz or 10MHz frequency, input via J53 on the rear panel.

#### Quadrature Oscillator

The oscillator's output frequency is set, on demand, between 10Hz and 1MHz, by setting RC time constants of its dual integrators; correcting to the actual demand by comparison with the output from the sine wave source. The output sinewave purity and constant amplitude are precisely defined by a sophisticated correction circuit. The RMS value of the sinewave is adjusted to the demanded output level, roughly proportional to the demanded output current. Timing data is output from the oscillator to synchronize the actions of the AC Reference Generator and AC/AC Comparator.

#### Voltage-Controlled Amplifier (VCA)

This has variable gain, amplifying the output of the Sinewave Source and providing a buffer for the output circuits. Its gain is determined by the measured difference between the RMS value of the sensed calibrator output and the AC Reference. The VCA provides the correcting fine adjustment to the output amplitude loop.

#### AC Voltage Ranging

##### 1V Range

This is the basic AC voltage range of the 4700. The AC working reference is variable between 1V and 2V RMS, it is compared in 1:1 ratio with the sensed output. The 1V Buffer output is thus parallel to the output I+ and I- terminals.

##### 100mV, 10mV and 1mV Ranges

The 1V Buffer output is reduced by precision attenuators before being connected to the terminals, the level being sensed before attenuation.

##### 10V, 100V and 1000V Ranges

The 1V Buffer output is amplified on each of these ranges. A separate amplifier is provided for the 10V range, the output sense signal being obtained at the terminals and attenuated before comparison with the reference. A common power amplifier is used for both 100V and 1000V ranges. On the 100V Range the output is fed directly to the terminals, on the optional 1000V Range the output is stepped up by a transformer. On both ranges, the sensed terminal voltage is reduced to the reference level by precision attenuators.

#### Output Sensing

On the 1V range and above, the output is sensed at the front panel Hi and Lo terminals. With Remote Sense selected, these are isolated from I+ and I-, but in Local Sense Hi is internally connected to I+, and Lo to I-. As described above, the 10V, 100V and 1000V ranges...

#### AC/AC Comparator

The comparator generates an error voltage proportional to the difference between the RMS values of the AC reference and the sensed output. It alternately samples a number of cycles from its 'Ref' and 'Sense' inputs, computes and integrates the squares of their instantaneous values, and uses a 'Sample and Hold' technique to subtract one from the other, this being the 'error' voltage to control the VCA. The loop thus controls the 4700 output so that the RMS value of the comparator's sense input equates to that of its reference input.

## Option 20 Current and Resistance

#### DC Current

On changing functions to DC Current, the Working Reference voltage is switched to drive a voltage-to-current converter, and the **OUTPUT** display legend is changed to  $\mu\text{A}$ ,  $\text{mA}$  or  $\text{A}$ . Over-voltage protection is provided, and the Output lines are fused.

#### AC Current

An AC Current output is produced by the voltage-to-current converter. The  $100\mu\text{A}$  and  $1\text{A}$  ranges are driven directly from the basic  $1\text{V}$  range, and the others from the  $10\text{V}$  range. Range selection is achieved by switching internal shunts. Output protection against over-voltage is provided, and the output lines are fused. The **OUTPUT** display legend is altered to  $\mu\text{A}$ ,  $\text{mA}$  or  $\text{A}$ .

#### Resistance

**Remote Sense.** One of a set of eight precision resistors is internally 4-wire connected to the **I+**, **I-**, **Hi** and **Lo** terminals by operation of each **RANGE** key. Simultaneously the 4-wire calibrated value of the resistor is displayed (**OUTPUT** display). Pressing the **OUTPUT Zero** key connects a true 4-wire short to the terminals, and the **OUTPUT** display indicates zero. This zero display value cannot be recalibrated.

**Local Sense (Remote Sense LED Unlit).** The connections to the resistor remain the same, but the display value includes the resistance of the connections from the **Hi** and **Lo** terminals to the resistor. The arrangement provides a calibrated 2-wire facility with external connection to the **Hi** and **Lo** terminals. The **Zero** key shorts the **Hi** and **Lo** terminals, in this case the resistance between the terminals is displayed and may be recalibrated. When  $\Omega$  is selected from any other function, the 4700 is forced into **Remote Sense**, but this may be deselected for 2-wire operation.

#### Autocalibration

By setting the **CAL ENABLE** security keyswitch on the rear panel to **ENABLE**, the 4700 can be calibrated. (Refer to Section 8). The output value is measured and the microprocessor is activated, to add any new corrections to factors already retained in non-volatile memory. The updated correction factors are applied in the normal **RUN** mode.

#### Processor

A 6802-series microprocessor controls the internal performance of the instrument, employing 26K bytes of program memory.

2K bytes of memory are used for stack and work space, and 2K bytes are made non-volatile by a battery-powered back-up supply, storing calibration correction factors.

With the exception of the Power **ON/OFF** switch, each front and rear panel control provides an input to the microprocessor system, which translates the information to command the 4700 analog and calibration functions.

The processor also controls the display, the IEEE 488 Interface Bus and the operation of the restart and error circuitry.

## SECTION 2 INSTALLATION

This section contains information and instructions for unpacking and installing the Datron 4700.

### Unpacking and Inspection

Every care is taken in the choice of packing materials to ensure that your equipment will reach you in perfect condition.

If the equipment has been subject to excessive mishandling in transit, the fact will probably be visible as external damage to the shipping carton. In the event of damage, the shipping container and cushioning material should be kept for the carrier's inspection.

Unpack the equipment and check for external damage to the case, sockets, keys etc. If damage is found, notify the carrier and your sales representative immediately.

Standard accessories supplied with the instrument are as described in Section 1.

### Preparation for Operation

**DANGER**  
THIS INSTRUMENT IS CAPABLE OF DELIVERING A LETHAL ELECTRIC SHOCK. THE I+, I-, Hi and Lo TERMINALS ARE MARKED WITH ⚡ SYMBOL TO WARN USERS OF THIS DANGER.

**UNDER NO CIRCUMSTANCES SHOULD USERS TOUCH ANY OF THE FRONT TERMINALS UNLESS THEY ARE FIRST SATISFIED THAT NO DANGEROUS VOLTAGE IS PRESENT.**

#### Power Input

The recess **POWER INPUT** plug, **POWER FUSE** and **LINE VOLTAGE SELECTOR** are contained in an integral filtered module at the center of the rear panel.

The protective window allows the fuse rating and line voltage selection to be inspected with the power socket connected. This window slides to the left once the socket has been disconnected, for access to the fuse and voltage selector printed circuit board.

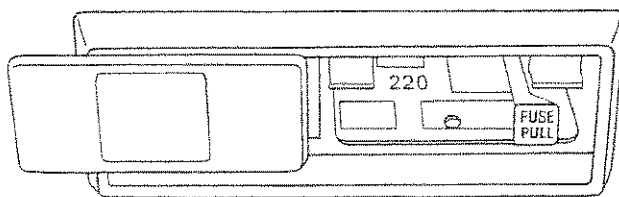

#### Power cable

The detachable supply cable, comprising two meters of 3-core PVC sheath cable permanently moulded to a fully-shrouded 3-pin socket, fits in the **POWER INPUT** plug recess, and should be pushed firmly home.

The supply lead should be connected to a grounded outlet ensuring that the ground lead is connected. Connect Black lead to Line, White lead to Neutral and Green lead to Ground. (European: Brown lead to Line, Blue lead to Neutral, and Green/Yellow lead to Ground).

#### Line voltage

The 4700 is operative within the line voltage ranges 100/115/120/220/230/240V  $\pm$  10%, 50 or 60Hz. To accommodate the ranges, a small PC selector board is housed beneath the **POWER FUSE**.

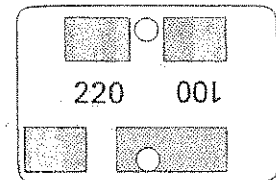
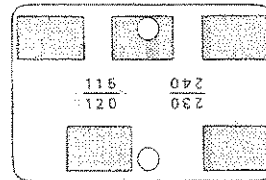

#### Operating Voltage Selection

**FIRST** ensure the **POWER CABLE** is removed. Slide the window to the left to reveal the fuse and PC selector board.

Draw the fuse-extractor to the left and remove the fuse.

Remove the PC selector board and rotate until the desired voltage is on the left of the upper surface. Reinsert the selector board firmly into the module slot.

The desired voltage is visible in the cutout below the fuse.

Return the fuse extractor to the normal position.

Insert the appropriate **POWER FUSE** (see over). Slide the window to the right and insert the **POWER CABLE**.

#### Power Fuse

The fuse rating is:

- 3.15A for 220/240V line supply
- 6.25A for 100/120V line supply

It is located behind the window in the **POWER INPUT** module on the rear panel, and should be of the anti-surge or **SLO BLO** type.

## WARNING

MAKE SURE THAT ONLY FUSES WITH THE REQUIRED RATED CURRENT AND OF THE SPECIFIED TYPE ARE USED FOR REPLACEMENT. THE USE OF MENDEED FUSES AND THE SHORT CIRCUITING OF FUSE-HOLDERS SHALL BE AVOIDED, AND RENDERS THE WARRANTY VOID.

## Bench Mounting

The instrument is fitted with six plastic feet. It is intended to stand flat on a bench, positioned so that the cooling-air inlet and exhaust apertures are not obstructed. It is recommended that at least 30cm (12 inches) of free space is at the rear.

## Rack Mounting

Option 90 permits the instrument to be mounted in a standard 19 inch cabinet.

### To Fit Option 90

#### CAUTION

Note that the 4700 is designed to be supported at front and rear. AT NO TIME should the 4700 be supported only by the front brackets. On no account should the upper and lower covers be removed.

Remove the two rear spacers from the case sides by releasing six screws. Fit the two rack-mounting slides to the rear of the case sides and secure using six of the shorter screws in the option kit.

N.B. The slides may be reversed to give rearward extension.

Fit the two rear rack-mounting ears to the rear of the cabinet, with tongues facing forward. In shallow cabinets it may be necessary to trim the tongue.

#### CAUTION

Assistance is required to fit the 4700 into the cabinet.

Lift the 4700 into position in the cabinet, locate the tongues in the slides, and carefully slide backwards until the front ears butt up against the cabinet front. Secure the front ears to the cabinet. Also clear ventilation for fan cooling to operate properly.

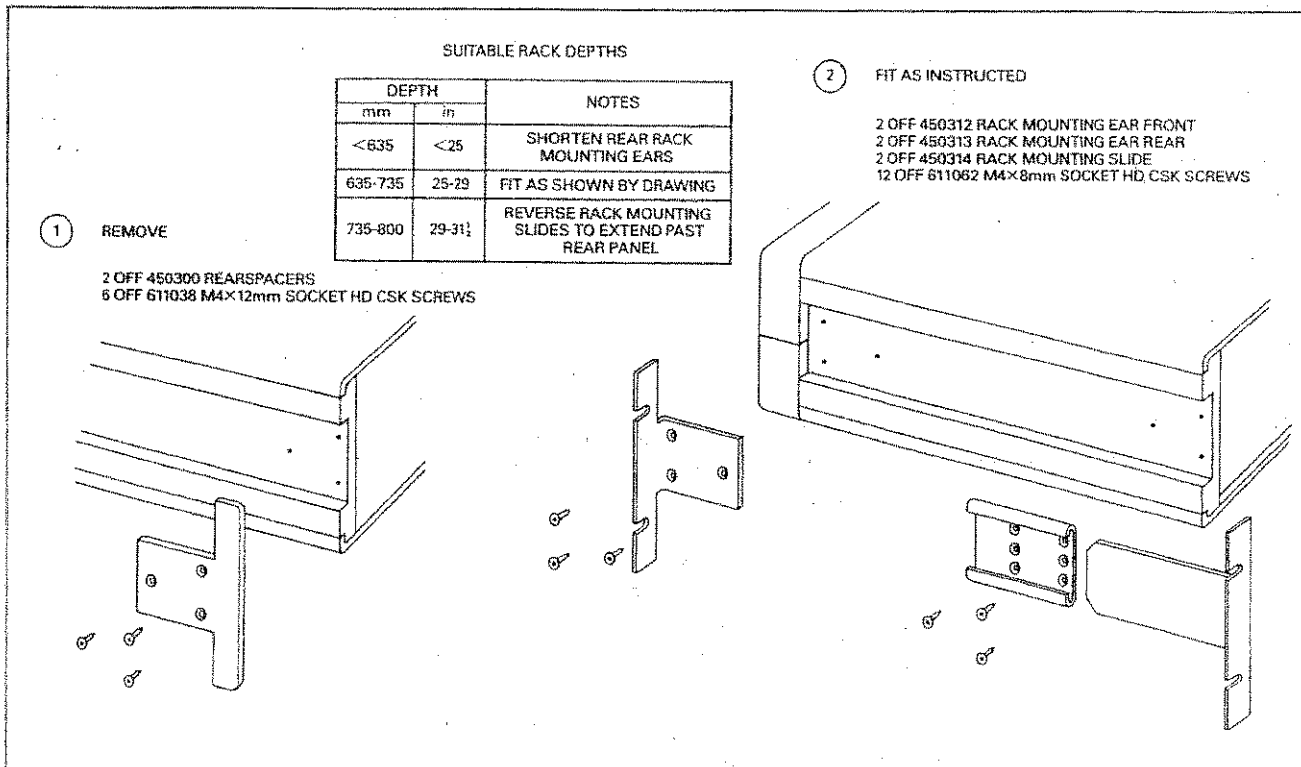

## Connectors and Pin Designations

### IEEE 488 Input/Output Socket J27.

The IEEE input/output is a 24-way connector that is directly compatible with the IEEE 488 interface and the IEC 625 Bus.

#### Pin Layout

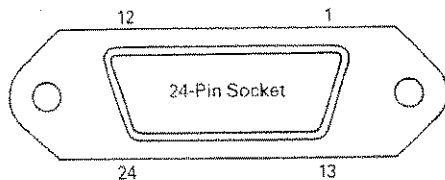

#### Pin Designations

J27 Pin No	Name	Description
1	DIO 1	Data Input Output Line 1
2	DIO 2	Data Input Output Line 2
3	DIO 3	Data Input Output Line 3
4	DIO 4	Data Input Output Line 4
5	EOI	End or Identify
6	DAV	Data Valid
7	NRFD	Not ready for Data
8	NDAC	Not Data Accepted
9	IFC	Interface Clear
10	SRQ	Service Request
11	ATN	Attention
12	SHIELD	Screening on cable (connected to 4700 Safety Ground)
13	DIO 5	Data Input Output Line 5
14	DIO 6	Data Input Output Line 6
15	DIO 7	Data Input Output Line 7
16	DIO 8	Data Input Output Line 8
17	REN	Remote Enable
18	GND 6	Gnd wire of twisted pair with DAV
19	GND 7	Gnd wire of twisted pair with NRFD
20	GND 8	Gnd wire of twisted pair with NDAC
21	GND 9	Gnd wire of twisted pair with IFC
22	GND 10	Gnd wire of twisted pair with SRQ
23	GND 11	Gnd wire of twisted pair with ATN
24	GND	4700 Logic Ground (internally connected to 4700 Safety Ground)

### Rear Output Terminals (Option 42)

The 4700 is fitted with either six front panel output terminals or six rear output terminals. The Rear Output alternative is fitted at the customer's request only at manufacture.

The 4700 cannot be fitted with both front and rear output terminals.

The functions of the six terminals are identical to those normally fitted on the front panel, and the external leads are connected in the same way. (See Section 4 for details).

### External Reference Frequency Input Socket J53

This BNC socket is located next to the cooling air intake filter. It enables the frequency synthesizer to be locked to a customer's own frequency standard provided that it meets the following criteria:  
Voltage: 500mV to 15V peak-to-peak.  
Frequency: 1MHz  $\pm$  1% or 10MHz  $\pm$  1%

N.B. The socket has an input resistance of approximately 50 $\Omega$

### External Reset Socket J54

#### Pin Layout

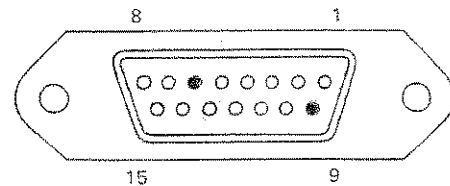

#### Pin Designation

J54 Pin	Signal
1-5	Not used
6	Reset line
7-8	Not used
9	Reset common
10-15	Not used

N.B. Some of the 'not used' pins may be wired for factory test purposes.

### External Reset Switch Wiring

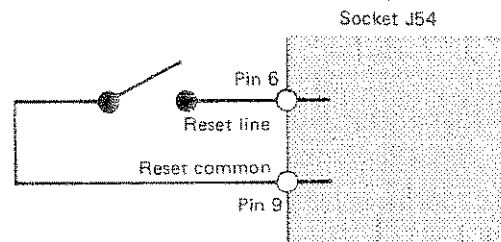



# DANGER HIGH VOLTAGE



**THIS INSTRUMENT IS CAPABLE  
OF DELIVERING  
A LETHAL ELECTRIC SHOCK!**



FRONT or REAR  
terminals carry the  
Full Output Voltage.

**THIS CAN KILL!**



Guard terminal is  
sensitive to over-  
voltage

**It can damage  
your instrument!**

Unless **you** are **sure** that  
it is **safe** to do so,  
**DO NOT TOUCH** the  
**I+ I- Hi or Lo leads**  
and **terminals**

# DANGER

# SECTION 3 OPERATING CONTROLS

This section summarizes the main operating features of the 4700. For detailed operating procedures refer to Section 4.

## Front Panel

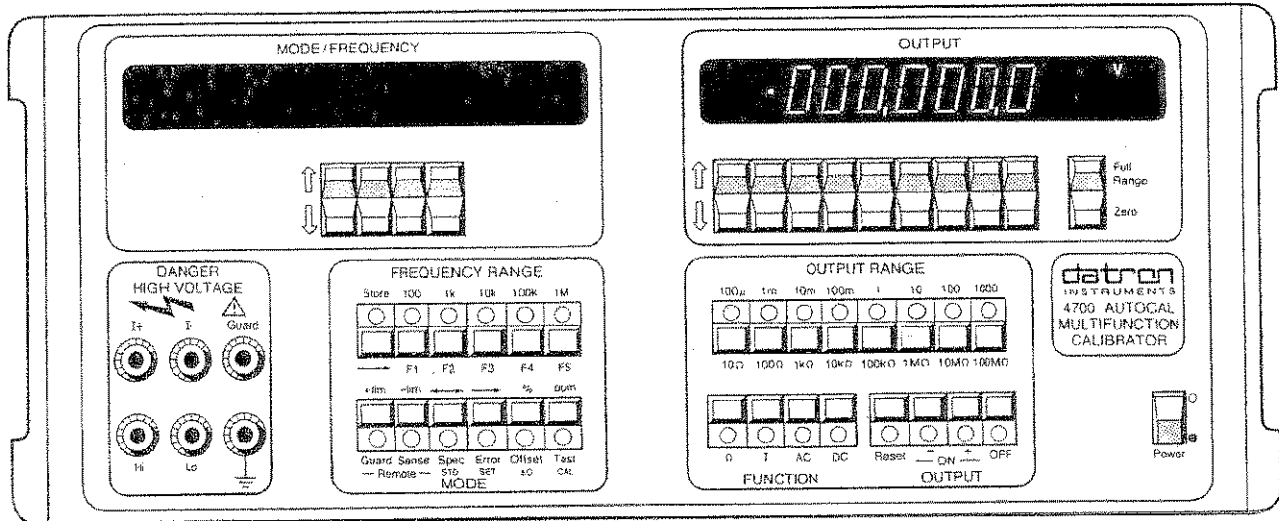

### Power-up State

The controls are outlined in blocks, left and right, associated with the appropriate display. The right-hand blocks generally deal with function and output definition, whereas the left-hand blocks are concerned with frequency, mode and terminal configurations.

### Front Panel Keys

All user commands from front panel keys are executed through main program firmware. A Key LED lit signifies that conditions are valid for the selected operation, and not merely that the key has made contact.

At any time, the instrument status is described by the combination of LED states, display values and display messages.

Generally, if an invalid condition is selected, an error message will be displayed and a buzzer will sound, the command is ignored and the 4700 remains in its previous state.

### Power Switch

#### WARNING

**THE POWER SWITCH SHOULD NOT BE SET TO ON UNTIL THE LINE VOLTAGE AND POWER FUSE RATING HAVE BEEN SELECTED AS DETAILED IN SECTION 2 (INSTALLATION)**

When set to the  OFF position, the 2-pole Power switch isolates the instrument from the supply.

When switched to  ON, the instrument powers up, runs a self-test program and is configured into the following state:

OUTPUT	OFF
FUNCTION	DC
OUTPUT RANGE	1
OUTPUT DISPLAY	.000,000,0V
FREQUENCY RANGE	Not selected
MODE/FREQUENCY	
DISPLAY	Blank
MODE	Not selected
Guard	Local connection (unlit)
Sense	Local connection (unlit)
Key LEDs Lit	OUTPUT OFF, DC, 1



## OUTPUT Switching

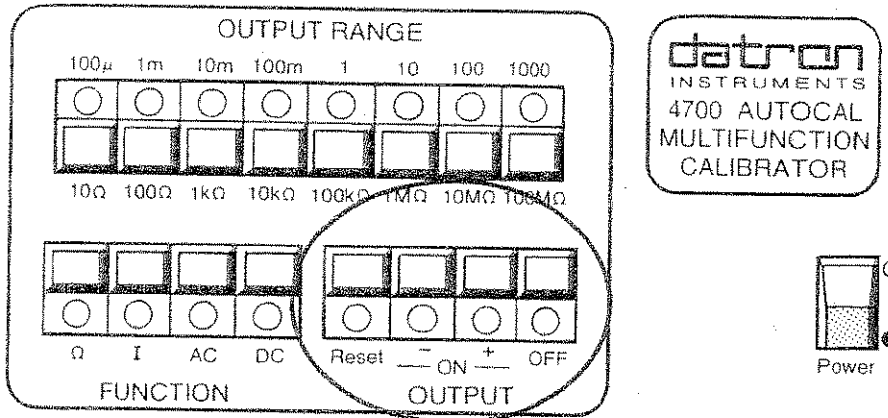

### OUTPUT ON/OFF

The 4700 should normally be connected and set up with its **output off**. This isolates the **I+**, **I-**, **Hi** and **Lo** terminals from their internal circuitry regardless of **RANGE**, **FUNCTION**, **FREQUENCY** or **MODE** selections. The **OUTPUT OFF LED** is lit.

Pressing the **OUTPUT ON** key connects the **I+**, **I-**, **Hi** and **Lo** terminals to their energized internal circuits.

### OUTPUT OFF Default

Certain instrument states are prohibited, and some transfers between states are restricted by program firmware. For safety reasons some of these transfers result in the output being switched **off**. Refer to Section 4, Operating Routines.

### OUTPUT ON - +

On DC Voltage or Current, the polarity at the Output terminals is determined by the Key used to switch the output on, as labelled. In addition, polarity may be reversed by using the  $\uparrow$  |  $\downarrow$  keys to step the output across zero value. The **ON LED**s describe the polarity **AT THE OUTPUT TERMINALS**, not on the **OUTPUT** display. (In "error" and "offset" modes these two could be opposite).

In AC Voltage, AC Current and Resistance functions, the **ON +** key will cause the selected outputs to appear at the output terminals. The **ON -** key will cause the error buzzer to sound and **Error 8** to appear in the **MODE/FREQUENCY** display.

### OUTPUT OFF Trip — Fail 5 Message

Under certain abnormal conditions which might compromise safety, the 4700 output will trip off, accompanied by a **FAIL 5** message on the **MODE** display. Control is removed from the front panel keys.

If the **FAIL 5** message is present, there is **no** automatic recovery from the tripped state whether internal conditions have or have not returned to normal.

### Reset Key

The **Reset Key** has two functions:

1. It allows a user to reset the safety trip to test whether conditions have returned to normal. If they have; the **FAIL** message will disappear, the previous instrument state will be restored but with **OUTPUT OFF**, and front panel control will be returned to the user. If conditions are still abnormal the **FAIL** state will persist, and a further attempt may be made after a suitable interval. The **Reset LED** is inoperative except in 'Test' mode.
2. It returns the instrument to power-up conditions in all cases except the following:
  - Self-test mode
  - **FAIL** conditions
  - In remote control mode (where it is inoperative).

### Other Messages

A full list of 4700 messages appears in Section 4. The fault conditions which generate Fail messages are analyzed in the Calibration and Servicing Handbook.

## FUNCTION Keys

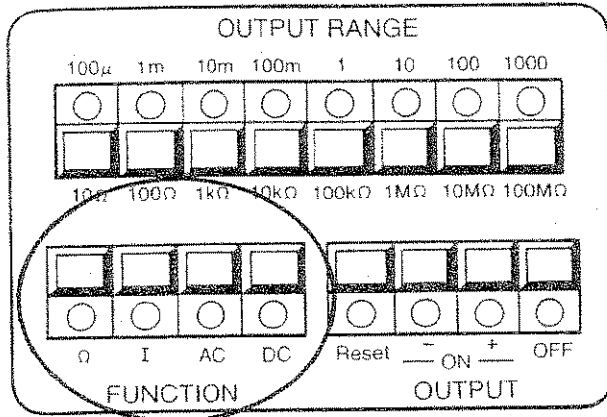

### Selected Function

DC  
AC  
Ω  
DC and I  
AC and I

### Specified Output

DC Voltage  
AC Voltage  
Resistance  
DC Current  
AC Current

or Error 9 and buzzer if Option 20 is not fitted

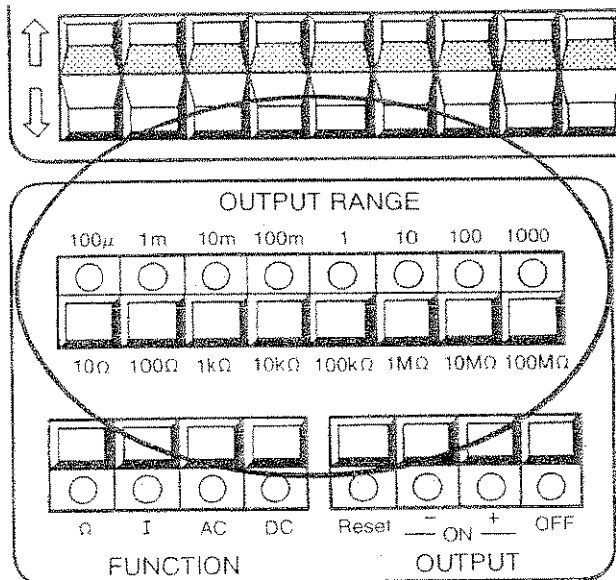

## OUTPUT RANGE Keys

Each **OUTPUT RANGE** key scales the output as selected by the user, setting the legend and decimal point on the **OUTPUT** display to match. Full range values for voltage and current are marked above the keys. Nominal values of each precision resistor for the Ω function are marked below the keys.

Voltage and current ranges are selectable as follows, the actual output value being selected by use of the **OUTPUT** display ↑|↓ keys:

DC Voltage : 100μV to 4000V  
AC Voltage : 1mV to 1000V RMS  
DC Current : 100μA to 1A  
AC Current : 100μA to 1A RMS  
Resistance : 10Ω to 100MΩ

If **OUTPUT** is **ON** when changing ranges, it remains on unless the change is to 1000V range, or ranging-up to more than 75V RMS in AC or 110V in DC on 100V range. In these cases **OUTPUT** defaults to **OFF**. Any range selection which would exceed the internally defined voltage-frequency limit is automatically inhibited. These limits are described on page 3-6.

Key selections	100 $\mu$	1m	10m	100m	1	10	100	1000
	10	100	1k	10k	100k	1M	10M	100M
DC Voltage	100 $\mu$ V	1mV	10mV	100mV	1V	10V	100V	1000V†
AC Voltage	*	1mV	10mV	100mV	1V	10V	100V	1000V†
DC Current†	100 $\mu$ A	1mA	10mA	100mA	1A	*	*	*
AC Current†	100 $\mu$ A	1mA	10mA	100mA	1A	*	*	*
Resistance†	10 $\Omega$	100 $\Omega$	1k $\Omega$	10k $\Omega$	100k $\Omega$	1M $\Omega$	10M $\Omega$	100M $\Omega$

\* Error 8

† Error 9 if option not fitted

### OUTPUT Display and $\uparrow/\downarrow$ Keys

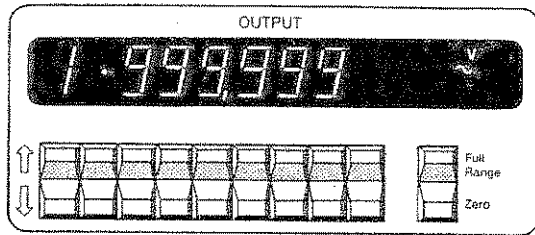

#### Output Resolution

The Output and display are resolved as follows:

Range	100 $\mu$	1m	10m	100m	1	10	100	1000
	10	100	1k	10k	100k	1M	10M	100M
DCV	4½	5½	6½	7½	7½	7½	7½	7½
ACV	—	4½	5½	6½	6½	6½	6½	6½
DCI	6½	6½	6½	6½	6½	—	—	—
ACI	6½	6½	6½	6½	6½	—	—	—
$\Omega$ (2-wire)	4½	5½	6½	7½	7½	7½	7½	7½
$\Omega$ (4-wire)	7½	7½	7½	7½	7½	7½	7½	7½

The **OUTPUT** display is supplemented by legends, which always indicate the correct units for the Range and Function selected.

#### Output and Display Control

Each vertical pair of  $\uparrow/\downarrow$  keys is assigned to the display digit above it. Thus the value registered on the display may be set within the range permitted by the function selected. Each momentary press of the  $\uparrow$  key adds 1 to its digit; pressing the  $\downarrow$  key subtracts 1. If **OUTPUT** is **ON**, the Output terminal value is also changed by the same increments as the display (subject to the instrument interlocks).

On  $\Omega$  ranges, only the overrange  $\uparrow/\downarrow$  keys are operative. These duplicate the action of the **Full Range/Zero** Keys.

The Resistance value displayed is the calibrated value of the standard internal resistor selected (not the nominal value). This may be updated during periodic calibration. The value displayed depends on the selection of **Local** (2-wire) or **Remote** (4-

wire) **Sense**, and should be recalibrated in the correct Sense mode (See Section 8).

#### Auto-Increment/Decrement

When a  $\uparrow/\downarrow$  key is pressed for more than ½ second, its digit is increased or decreased at a rate of approximately 3 digits per second until the key is released.

#### Overflow and Underflow

As a digit is stepped from 9 to 0, the value of the next higher-order digit is increased by 1. Stepping from 0 to 9 decreases the value by 1. The whole display therefore acts as a counter, with full 'carry' and 'borrow' action.

#### Range of Adjustment for DC Functions

The  $\uparrow/\downarrow$  keys adjust the readings between a minimum of 00000000 and 99999999 full scale on 100mV — 100V and between 00000000 and 99999999 for Current Ranges. The 1000V Range has a Full Scale of 1100.0000; the 100 $\mu$ V, 1mV and 10mV ranges are truncated.

### Range of Adjustment for AC Functions

The  $\uparrow/\downarrow$  keys adjust the reading between a minimum of 0090000 (9% of Nominal Range), and maximum of 1999999 full scale on 100mV — 100V and Current Ranges. The 1000V Range has a Full Scale of 1100.000; the 1mV and 10mV ranges are truncated.

**N.B.** There is no range of adjustment on Resistance functions.

### Leading Zeroes

For fractional readings, a leading zero is presented to the left of the decimal point to emphasise its position, except for **OUTPUT RANGE** selections 1m and 1.

**DC ZERO and polarity.** On DC voltage and current, a polarity sign is present except at zero. The numerical display represents the magnitude of the output.

As the display value is stepped to zero, the polarity sign disappears, and the opposite sign appears as stepping continues in the same direction. If the **OUTPUT** is **ON** during the sequence, the change in output polarity is signalled by a changeover from one polarity **ON** LED to the other.

**N.B.** If the 4700 is in **Offset Mode**, with an offset present, the display and output zeroes do not coincide. It is therefore possible to have a **positive** sign on the display, and the **ON**—LED lit; and vice-versa.

When using the  $\uparrow/\downarrow$  keys or **Zero** key to obtain a zero, the polarity is not changed over and the same **OUTPUT ON** LED remains lit. The polarity LEDs change over only when the opposite polarity appears at the output terminals.

### Full Range Key

When the **Full Range** key is pressed, the display reverts to the nominal value of the range selected. If **OUTPUT** is already **ON**, the terminal value follows the display value unless:

1. The combination of output voltage and frequency would exceed the instrument's internally defined limits. (Refer to Section 6).
2. **Offset or Error Mode** is selected: the user-input offset or gain error is not cancelled from the output.

### Zero key

This reduces the display value to zero. If **OUTPUT** is **ON**, the terminal value is also set to zero:

DC Voltage — an active zero is presented to the

output terminals.

AC Voltage — an internal short circuit is connected across the output terminals.

DC and AC Current — output terminals are open-circuited.

On  $\Omega$  ranges in **Remote Sense** with **OUTPUT ON**, the **Zero** key connects a true 4-wire internal short circuit to the **OUTPUT** terminals as shown below. With **Remote Sense** LED **UNLIT**, the same short is connected, but the actual resistive value of this short may be calibrated (See Section 8 and diagram below).

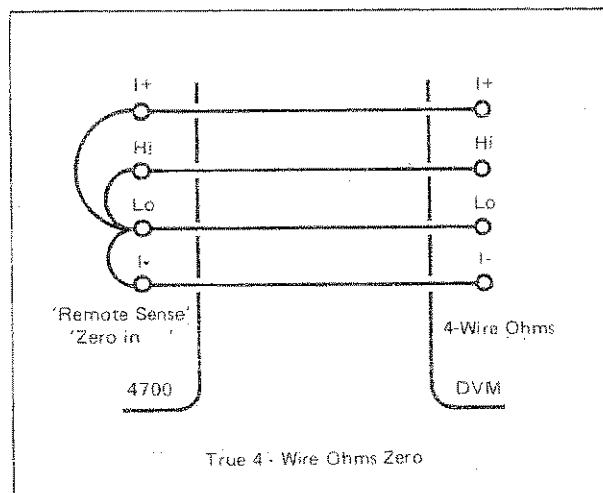

### Deselection of Zero in AC Functions

The size of the characters on the 'Zero' display is significant. A half-size '0' above any  $\uparrow/\downarrow$  key indicates that it cannot be used to deselect Zero, because it increments values which are less than 10% of nominal range. Any  $\uparrow$  key with a full-size '0' above it (and any key to its left) deselects Zero and adds its increment.

### Selection of High Voltage Outputs

The 4700 is capable of delivering **LETHAL** output voltages so program interlocks are used to ensure that users do not inadvertently select outputs in excess of 110V in DC or 75V RMS in AC. Details of the High Voltage selection procedure are given in Section 4.

### Frequency

The AC voltage output of the 4700 extends from 10Hz to 1MHz in five overlapping decade ranges, at a resolution of 1% of nominal Frequency Range. Any five frequency values within the range of the instrument can be stored in volatile memory.

## FREQUENCY RANGE keys

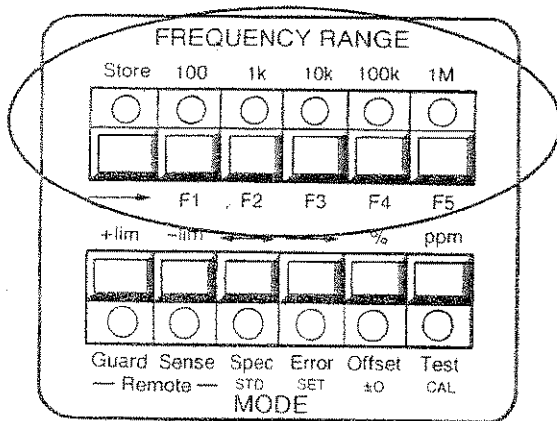

### Decade Ranging

Generally, selection of a new range changes the frequency by a whole number of decades; but ranging-up from a frequency between 10Hz and 30Hz, or ranging-up to the 1MHz range when the decade frequency would have been higher, causes **Error 7** to be displayed and buzzer to sound.

### Selection of Nominal Range Value

Once a Frequency Range has been selected, it can be set to its nominal value by re-pressing its key.

## FREQUENCY DISPLAY

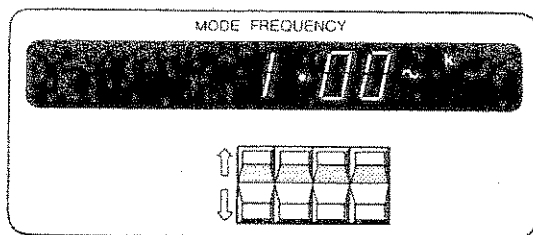

### Resolution

The output frequency is adjustable in steps of 1% of the selected **FREQUENCY RANGE** nominal value, matching the display resolution. Legends are appended on the display as appropriate, and a leading zero is presented to the left of the decimal point for fractional values.

### FREQUENCY $\uparrow/\downarrow$ Control Keys

Each vertical pair of  $\uparrow/\downarrow$  keys is assigned to the display digit above it. The frequency registered on the display is adjusted by manipulation of these keys. Each momentary press of the  $\uparrow$  key adds 1 to its digit, and each  $\downarrow$  key subtracts 1. If **OUTPUT** is **ON**, the output frequency is also changed by the same increments as the display (subject to the instrument interlocks). Keys below decimal points are inactive.

### Auto-increment/Decrement

When a  $\uparrow/\downarrow$  key is pressed for more than  $\frac{1}{2}$  second its digit is increased or decreased at a rate of approximately 3 digits per second until the key is released.

### Overflow and Underflow

As a digit is stepped from 9 to 0, the value of the next higher-order digit is increased by 1. Stepping from 0 to 9 decreases the value by 1. The whole display therefore acts as a counter, with full 'carry' and 'borrow' action.

### Autoranging

Stepping the frequency beyond the span of a range automatically switches range up or down, but further steps are inhibited until the  $\uparrow$  or  $\downarrow$  key is released (the key could be below a decimal point). When the range-change occurs, the alarm buzzer sounds and the **FREQUENCY** display is blanked for approx. 1 second.

When the display is reinstated, the 4700 has remembered the last frequency on the old range, and sets the new range to its next incremental frequency in the original direction. After releasing the original key, stepping can be continued to any increments of the new range.

### Autorange Limits

The 4700 displays an **Error 7** and sounds its buzzer when any attempted frequency increment or decrement is made which would produce an invalid combination of **FUNCTION**, **OUTPUT RANGE** or **FREQUENCY**. Neither will it increment or decrement to a frequency beyond the limits of the next frequency range up or down.

## OUTPUT/FREQUENCY CONSTRAINTS

### AC Voltage and Frequency

Under most conditions, the output amplitude and frequency are adjustable throughout their full scales:

Voltages — from  $90\mu\text{V}$  to 1100V RMS

Frequencies — from 10Hz to 1MHz.

On the 100V and 1000V Ranges, certain combinations of voltage and frequency cannot be selected.

The diagram below illustrates the boundaries.

The 10V Range span is also shown for comparison.

The 4700 refuses to select any Voltage/Frequency combination outside these constraints. The temporary message **Error 7** is displayed for approximately 1 second before reverting to the original display.

**AC Current and Frequency**

AC Current is adjustable between  $9\mu\text{A}$  and 2A RMS at frequencies from 10Hz to 5kHz (all Current Ranges have the same span). **Error 7** indicates an invalid Current/Frequency selection.

**FREQUENCY MEMORY**

This facility allows storage of up to five user-selected frequencies. Once stored, each can easily be retrieved or changed from the front panel. They are retained until power is removed from the instrument or reset key is depressed.

**Store Key**

Only five of the **FREQUENCY RANGE** keys select ranges. The first press of the sixth key, **Store**, reassigns the other five as frequency memories. It has toggle action: a second press deselects the memory function.

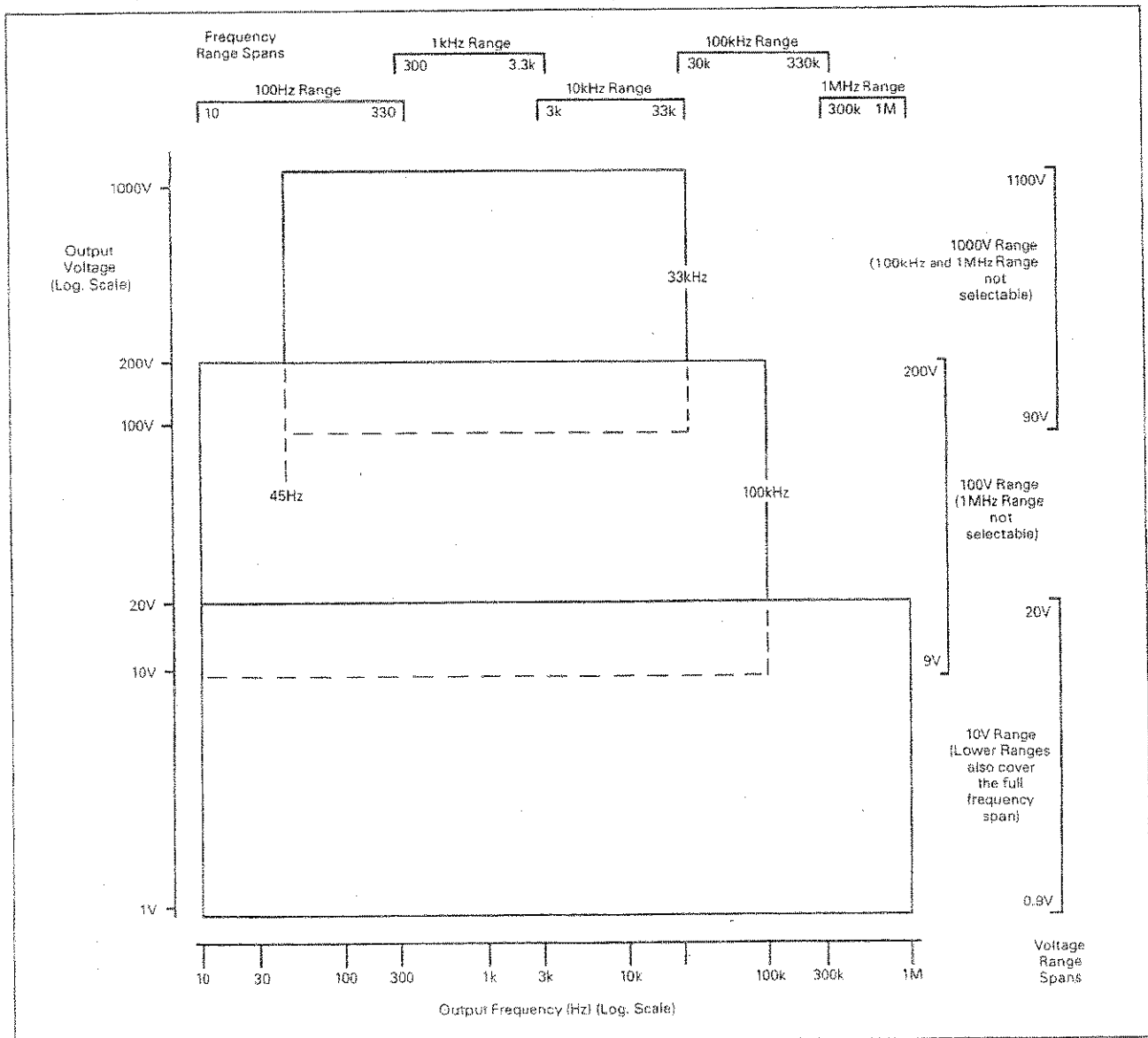
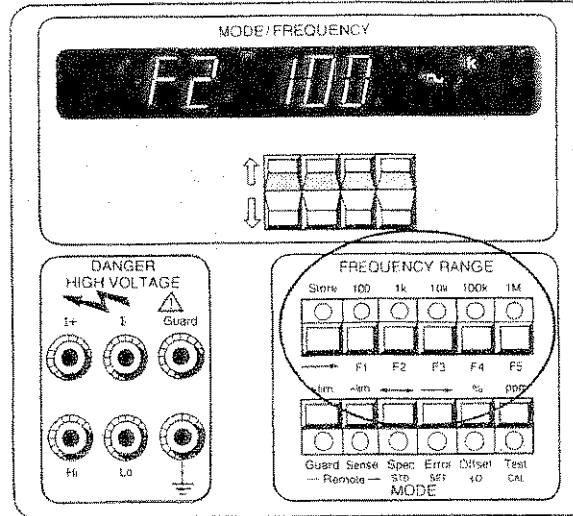

### F1-F5 Memory keys

When the **Store LED** is ON, these keys select individual memory locations.

**N.B.** Although the **FREQUENCY RANGE** keys double as memory selectors, this does not imply that a particular memory can only accept frequencies from its key's range. It is emphasized that any displayable frequency can be stored in any of the five locations.

### Power-up Default

Because the stores are volatile, the following default frequencies are stored in the five memory locations each time the 4700 is powered-up:

F1	30Hz
F2	300Hz
F3	3kHz
F4	30kHz
F5	300kHz

Details of storage and retrieval procedures are described in Section 4.

### MODE Selection Keys

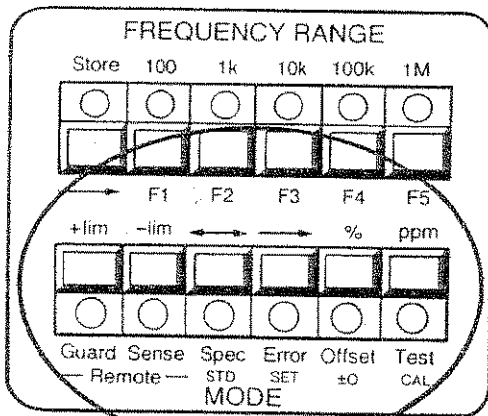

The **MODE** selection keys are located on the lower left of the front panel. The Remote Guard and Remote Sense keys are described under **I+**, **I-**, **Hi**, **Lo**, **Guard** and  $\perp$

**STD**, **SET**, **±0** and **CAL** are calibration modes, printed in red and described in Section 8.

### SPEC MODE

The **Spec** key controls the toggle-action 'Specification' function. By pressing the key, the 4700 specification tolerances are displayed on the **MODE** display, referred to its current **FUNCTION**, **OUTPUT**, **FREQUENCY** and

**CALIBRATION INTERVAL** selection. A second press cancels the function. For **24-hour** calibration intervals, the 'accuracy relative to calibration standards' figures are displayed but for **90 days** and **1 year** intervals they are 'Traceable' accuracy figures which include Datron's Calibration Uncertainty.

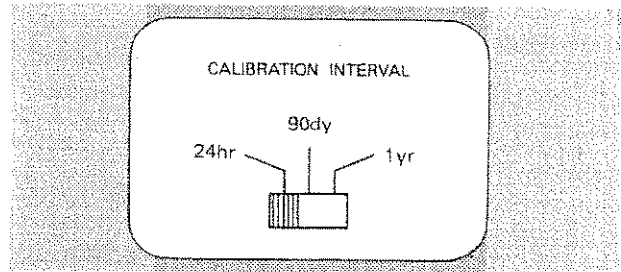

Rear Panel **CALIBRATION INTERVAL** switch

While in **Spec** mode, all primary functions of the other **MODE** keys are cancelled (although the selected Guard and Sense connections remain). The keys are reassigned to their secondary functions: **+lim**, **-lim**, **%** and **ppm** become active. When **Spec** mode is initiated, the magnitude of the specification tolerance itself determines whether **ppm** or **%** is selected. The arrow  $\leftrightarrow$  above the **Spec** key shows that all four secondary modes are available.

Full details of the operation of Specification mode are given in Section 4.

### ERROR AND OFFSET MODES

These keys are used to deviate the output at the terminals from the value on the **OUTPUT** display. The two modes may be selected together.

### Error and Offset Modes NOT Selected

The terminal value is a linear function of the **OUTPUT DISPLAY** value:

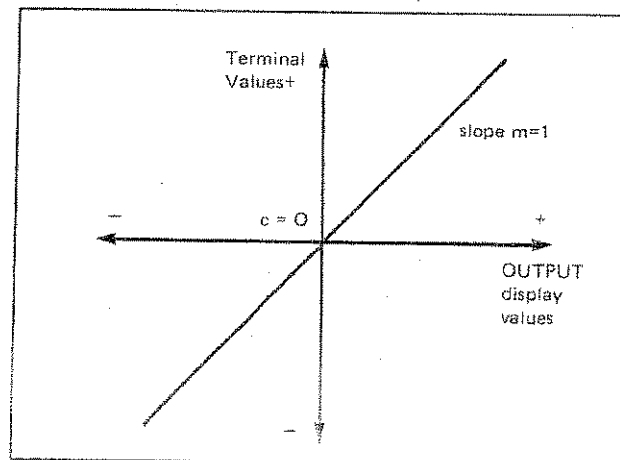

**Error mode selected**

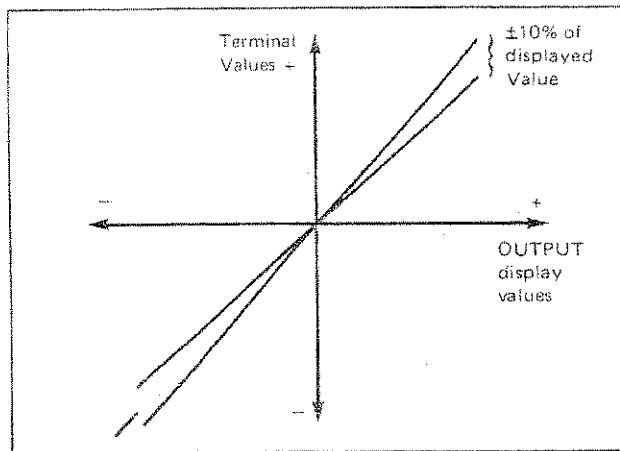

Full details of the operation of Error mode are given in Section 4.

**Offset mode selected (DC Functions only)**

In **Offset mode**, the intercept (c) may be adjusted to any value within the Offset limit.

Offset Limits: 100 $\mu$ V and 1mV Ranges:  $\pm$ 200 $\mu$ V.  
Other Ranges:  $\pm$ 2% of Full Range value.

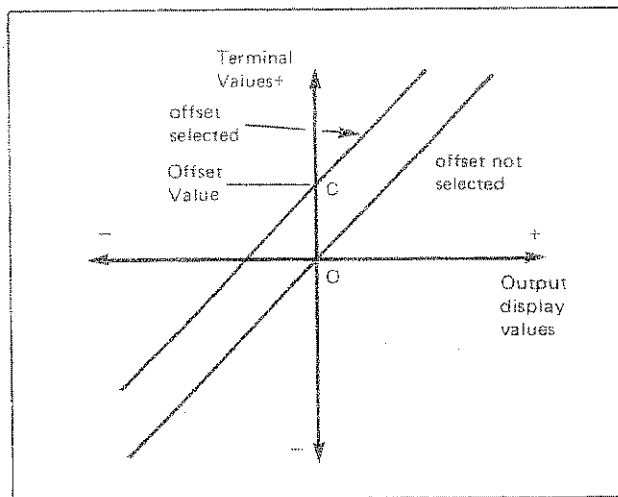

**Offset and Error Mode Combination.**

**Offset** cannot be selected or deselected when the 4700 is already in **Error Mode**.

The intercept (c) is established first in **Offset mode**, then the slope (m) is adjusted in **Error mode**.

Full details of the operation of Error, Offset and the combined mode are given in Section 4.

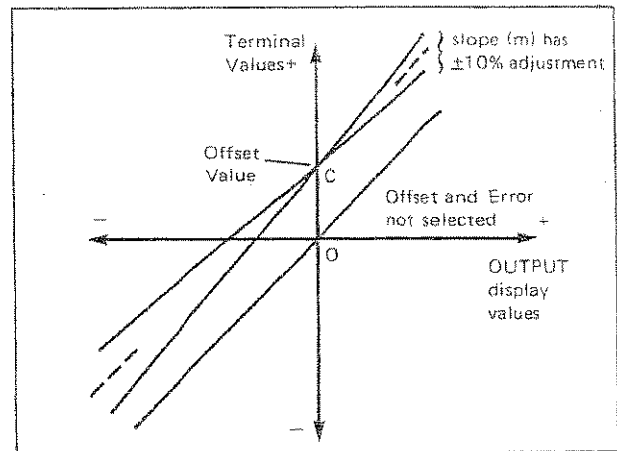

**TEST MODE**

**Test mode selected**

Full details of the operations in **Test mode** are given in Section 4.

I+, I-, Hi, Lo, Guard and  $\perp$   
(Ground) Terminals

**Local and Remote Switching**

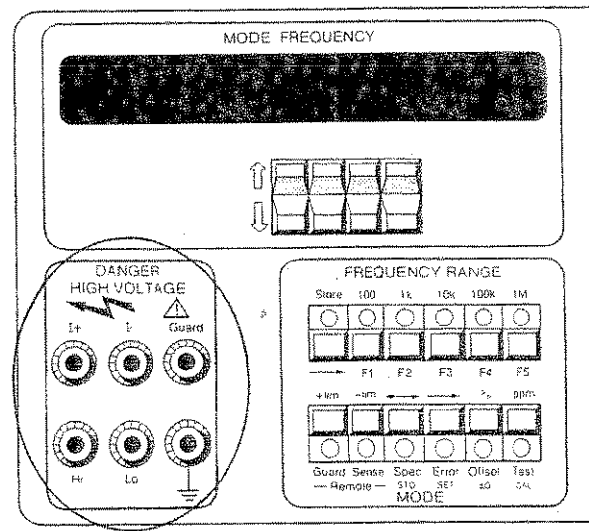

These terminals are located on the lower left of the Front Panel.

**I+ and I- Terminals**

The output from the internal power circuits is delivered to the I+ terminal, I- being its Return Analog Common.

**Hi and Lo Terminals**

These terminals provide a differential input to the amplitude sensing circuitry.



#### Remote Sense

The **Remote Sense** key has 'toggle' action. Successive presses alternate between **ON** and **OFF**.

**N.B. Sense connections can only be switched with OUTPUT OFF.**

The specified voltage output of the 4700 may be produced either at its output terminals (Local Sense for high impedance loads) or at the load terminals (Remote Sense for cases in which lead resistance and load impedance produce a significant effect).

With **Remote Sense OFF**, the I+ terminal is isolated, and the voltage output is fed to the **Hi** terminal.

With **Remote Sense ON**, the output voltage is fed across the I+ and I- terminals only, and must be sensed externally, using leads connected to the **Hi** and **Lo** terminals.

**Remote Sense** is not available on 100 $\mu$ V — 100mV ranges. It is not applicable to Current outputs.

On **Ohms** ranges, **Local Sense** is used for 2-wire connections, and **Remote Sense** for 4-wire. (Changing **FUNCTION** into  $\Omega$  forces the 4700 into **Remote Sense**, but this may be deselected for 2-wire operation). The **Remote Sense LED** always indicates the true connection:

Lit = Remote; Unlit = Local.

#### Guard Terminal

The Guard terminal is permanently connected to the internal guard shields:

#### Remote Guard

The **Remote Guard** key has 'toggle' action. Successive presses alternate between **ON** and **OFF**.

With **Remote Guard OFF**, Guard is internally connected to the I- terminal.

With **Remote Guard ON**, the internal link to I- is removed. The Guard terminal can then be connected externally to reduce common mode interference.

#### Ground Terminal

The  $\text{⏏}$  (Ground) terminal connects directly to the 4700 internal Ground shields and to Safety Ground via the power-cable.

#### Output Connections

Connections to the output terminals may be made either with leads or via a shrouded connector.

For Voltage outputs in local sense the two leads should be attached to the **Hi** and **Lo** terminals.

Various configurations of 4700 load connections are detailed in Section 4.

# Rear Panel

(Shown with alternative Rear Output terminals).

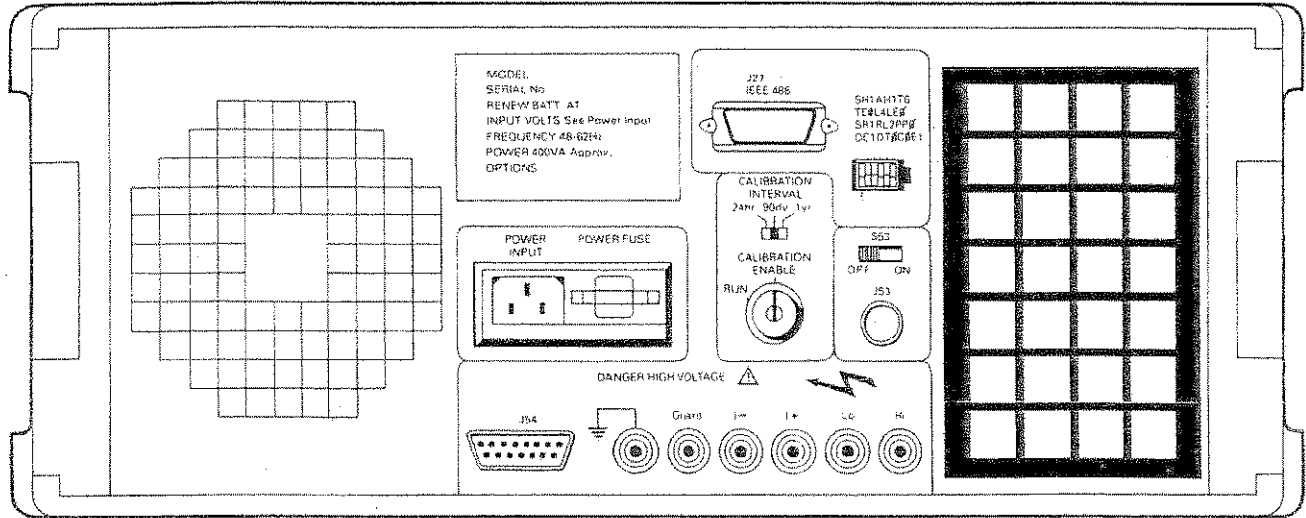

## POWER INPUT

The recessed **POWER INPUT** plug, **POWER FUSE** and **LINE VOLTAGE SELECTOR** are located in the center of the rear panel, contained within a single moulded unit. Details of connections, selection of line voltage and fuse are given in Section 2.

## REAR OUTPUT ALTERNATIVE (Option 42)

This can be incorporated at manufacture, to provide six output terminals on the rear panel instead of the six on the front. Their functions and connections are identical.

## SOCKET J53

(External Reference Frequency Input)

This BNC socket is located next to the cooling air intake filter. It may be used to lock the internal frequency synthesizer to a customer's own frequency standard. Voltage and frequency criteria are given in Section 2. An on-off switch, S53, located above this socket is provided to enable this facility. If the switch is on and an external frequency is not present, error message '**Error EF**' is displayed.

## SOCKET J54 (External Reset)

This D-type socket is located next to the optional rear output connectors. It may be used to input an external reset to restore the 4700 to its power-up state of DCV, 1V Range etc. if required. Pin Layout, Pin Designation and Switch Wiring details are given in Section 2.

## SOCKET J27 (IEEE 488 Input/Output)

The IEEE 488 Input/Output (D-type) socket J27 is a 24-way micro-ribbon connector that is directly compatible with the IEEE 488 interface and the IEC-defined system.

J27 is located at the top of the rear panel, outlined with the IEEE 488 address switch. The pin layout and designations appear in Sections 2 and 5.

## IEEE 488 ADDRESS SWITCH

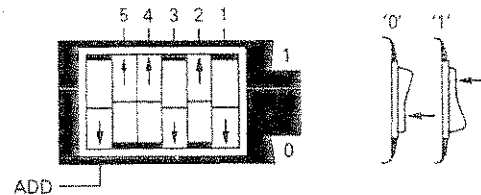

The 4700 may be addressed for use on the IEEE 488 interface bus. The address settings are given in Section 5.



# DANGER HIGH VOLTAGE



**THIS INSTRUMENT IS CAPABLE  
OF DELIVERING  
A LETHAL ELECTRIC SHOCK!**



FRONT or REAR  
terminals carry the  
Full Output Voltage.

**THIS CAN KILL!**



Guard terminal is  
sensitive to over-  
voltage

**It can damage  
your instrument!**

Unless **you** are **sure** that  
it is **safe** to do so,  
**DO NOT TOUCH** the  
**I+ I- Hi or Lo leads**  
and **terminals**

# DANGER

# SECTION 4 USING THE DATRON 4700

## Preliminaries

Before using the instrument it is important that it has been correctly installed as detailed in Section 2.

## Limiting Characteristics

The following details are given in Section 6:

Function	Characteristics
All functions	Peak terminal voltages
DC Voltage	Output resistance and current limit
AC Voltage	Output resistance and current limit; capacitive loading limits
DC Current	Maximum load resistance and maximum compliance
AC Current	Maximum load resistance and maximum compliance
Resistance	Maximum currents and accuracy de-rating factors

## SAFETY

The 4700 is designed to be Class 1 equipment as defined in IEC Publication 348 and UL 1244, concerning safety requirements.

Protection is provided by a direct connection via the power cable from ground to exposed metal parts and internal ground screens.

The line connection must only be inserted in a socket outlet provided with a protective ground contact, and continuity of the ground conductor must be assured between the socket and the instrument.

### WARNING:

**ANY INTERRUPTION OF THE PROTECTIVE GROUND CONDUCTOR INSIDE OR OUTSIDE THE INSTRUMENT, OR DISCONNECTION OF THE PROTECTIVE GROUND TERMINAL MAY MAKE THE APPARATUS DANGEROUS. INTENTIONAL INTERRUPTION IS PROHIBITED.**

**THE TERMINALS MARKED WITH THE  SYMBOL CARRY THE OUTPUT OF THE 4700. THESE TERMINALS AND ANY OTHER CONNECTIONS TO THE LOAD UNDER TEST COULD CARRY LETHAL VOLTAGES.**

**UNDER NO CIRCUMSTANCES SHOULD USERS TOUCH ANY OF THE FRONT (OR REAR) PANEL TERMINALS UNLESS THEY ARE FIRST SATISFIED THAT NO DANGEROUS VOLTAGE IS PRESENT.**

### CAUTION:

THE  SYMBOL IS USED TO REMIND THE USER OF SPECIAL PRECAUTIONS DETAILED IN THIS HANDBOOK AND IS PLACED ADJACENT TO TERMINALS THAT ARE SENSITIVE TO OVERVOLTAGE CONDITIONS.

REFER TO SECTION 6.

## Interconnections

### IMPORTANCE OF CORRECT CONNECTIONS

The 4700 has been designed for use as an accurate source for precision calibration. To match the external circuitry to its superior specification, it is essential to take great care in making connections to the load.

### SOURCES OF ERROR

#### Thermal EMFs

These can give rise to series (normal) mode interference, particularly for low voltage outputs, and where large currents have a heating effect at thermo-electric junctions. Draughts can cause unbalanced cooling in an otherwise thermo-electrically balanced measuring circuit.

#### E-M Interference

Noisy or intense electric, magnetic and electromagnetic effects in the vicinity can disturb the measurement circuit.

Some typical sources are:

- Proximity of large electric fields.
- Fluorescent lighting.
- Inadequate screening, filtering or grounding of power lines.
- Transients from local switching.
- Induction and radiation fields of local E-M transmitters.
- Excessive common mode voltages between source and load.

The disturbances may be magnified by the user's hand capacitance. Electrical interference has greatest effect in high impedance circuits. Separation of leads and creation of loops in the circuit can intensify the disturbances.

#### Lead Impedance

The impedance of the connecting leads can drop significant voltages between the source and load, and generate adverse phasing effects particularly if the leads are long or the current in them is high.

#### Lead Insulation Leakage

This can cause significant errors in measurement circuits at high voltages. Some insulating materials suffer greater losses than others e.g. PVC has more leakage than PTFE.

## AVOIDANCE TACTICS

#### Thermal EMFs

Screen thermal junctions from draughts.

Allow time for thermal equilibrium to be reached before taking readings.

Use conductors, joints and terminals with a good margin of current-carrying capacity.

Avoid thermo-electric junctions where possible:

e.g. Use untinned single-strand copper wire of high purity. Avoid making connections through Nickel, Tin, Brass and Aluminium. If oxidation is a problem use gold-plated copper terminals, and replace the terminals before the plating wears off. If joints must be soldered, low-thermal solders are available, but crimped joints are preferred. Use low-thermal switches and relays where they form part of the measuring circuits.

Balance one thermal EMF against another in opposition, where possible, (switch and relay contacts, terminals etc.)

#### E-M Interference

Choose as 'quiet' a site as possible (a screened cage may be necessary if interference is heavy).

Suppress as many sources as possible.

Always keep interconnecting leads as short as possible, especially unscreened lengths.

Run leads together as twisted pairs in a common screen to reduce loop pick-up area, but beware of leakage problems and excessive capacitance.

Where both source and load are floating, connect I— to ground at the source to reduce common mode voltages.

#### Lead Impedance

Keep all leads as short as possible. Use conductors with a good margin of current-carrying capacity. Use Remote Sense and 4-wire connections where necessary to establish the 4700 output specification

at the load. Use 4-wire connections for values of resistance below  $1k\Omega$ .

#### Lead Insulation Leakage

Choose low-loss insulated leads — PTFE is preferred to PVC.

When running leads together in screened pairs, avoid large voltages between leads in the same screen, especially if using PVC insulation.

#### Remote/Local Sense Configurations

The 4700 terminals are configured as follows:

Voltage ranges  $100\mu V$ ,  $1mV$ ,  $10mV$ ,  $100mV$

— Local sense only.

$1V$ ,  $10V$ ,  $100V$ ,  $1000V$

— user selects Local or Remote sense.

All Current ranges

— Local sense only.

All Resistance ranges

— Remote Sense gives 4-wire connection.

— Local Sense provides 2-wire connection capability.

The key LED indicates the true connection:

Lit = Remote, Unlit = Local.

N.B. When changing to  $\Omega$  function, the 4700 is automatically forced into **Remote Sense** for 4-wire operation.

## 4700 – CONNECTIONS TO THE LOAD

#### General Considerations

The choice of connection method is influenced by several factors:

##### a. Loading Effects

4-wire connections should be used for low load impedances. For high impedance loads, 2-wire connections can be employed.

The ratio :  $\frac{\text{Total Lead Resistance}}{\text{Load Resistance}}$

gives the approximate error for 2-wire connection at low frequencies.

e.g. Two  $\frac{1}{2}$ -Ohm leads with a load of  $100k\Omega$  produce an error of approx. 10ppm.

At frequencies higher than about 100kHz, the error is also modified by reactive effects.

##### b. Noise and Output Level

Providing the E-M environment is reasonably quiet, interference due to noise pickup in the load connection is insignificant for outputs of more

than about 100mV, so unscreened leads can be used. But at lower signal levels, or in noisier environments, it is advisable to use screened cable.

c. **Common Mode Disturbances**

When in Local Guard, the guard shields and tracks for the Sense circuitry are connected internally to 'I-', the low impedance terminal of the 4700 output power source. This classical connection effectively guards out internal common mode disturbances. To reduce external disturbances it is advisable to make only one ground connection to the measurement circuit, and in the case of a guarded DMM, to make use of its external guard facilities. Also, where a line-powered load (such as a DMM being calibrated) has a ground connection, it should be to the same line ground as the 4700.

d. **High Frequency Effects**

i. **Voltage.** Up to about 100kHz, for outputs above 100mV, it is possible to use pairs of unscreened wires, provided that the E-M environment is quiet. Twist or run leads together; keep length less than 1 meter.

Above 100kHz, both lead and load capacitances reduce the load impedance. Similarly, lead and load inductances combine to increase the load impedance with frequency (but heavily reactive loads should be avoided). It is therefore advisable to make leads from low-capacitance coaxial or twin-axial cable. To avoid mutual coupling, Sense and Power leads should not run together in the same screen.

ii. **Current.** Above about 1kHz, with low output currents, high lead capacitance can introduce shunt errors. To reduce these errors, the leads should be kept as short as possible, and be of low-capacitance.

e. **DANGER.**

**THE 4700 OUTPUT CIRCUITS ARE NOT INTERNALLY CONNECTED TO GROUND. USERS ARE STRONGLY ADVISED TO CONNECT L<sub>0</sub> OR I- EXTERNALLY TO GROUND (PREFERABLY AT THEIR COMMON JUNCTION), WHEN THE 4700 IS TO BE USED ON THE 100V OR 1000V RANGE. THIS ELIMINATES THE RISK OF L<sub>0</sub> AND I- FLOATING TO HIGH VOLTAGE.**

**Setting Priorities**

Because of:

- a. the variety of environmental conditions and loads likely to be encountered when using the 4700,
  - b. the extensive set of combinations of outputs from the instrument, and
  - c. the accuracy required;
- it is unrealistic to describe a definitive 'best' general method of connection to the load.

Combinations of the above factors can lead to conflicting requirements, and users may be faced with a choice between methods. In these cases it is sometimes necessary to arrive at a compromise solution by setting priorities.

**Suggested Lead Connections for the 4700**

Six suggestions for connecting the 4700 to its load are illustrated in the following pages 4-4 and 4-5. Each has found use with the combination of factors described, and together they cover the majority of predicted requirements.

# Typical Lead Connections

## Voltage and Resistance Outputs

**CAUTION:** All leads and cables must be proofed to at least 2kV.

### Simple 2-wire Connection

Use for many applications where:

The voltage drop in the leads is insignificant.

The E-M environment is 'quiet'.

External common-mode voltages are insignificant.

Use for measurements in the following ranges:

Voltage	DCV $\geq 100\text{mV}$
	ACV $\geq 100\text{mV}$
Frequency	$F < 100\text{kHz}$
Resistance	$1\text{k}\Omega \leq R < 1\text{M}\Omega$

**N.B.** After selecting  $\Omega$ , Remote Sense must be cancelled for 2-wire operation.

Select Local Sense and Local Guard.

Keep leads as short as possible, (not longer than 1 meter-twisted pair is preferable).

**On 100V/1000V Ranges, Ground the Lo line for Safety.**

Note: Refer also to reactive load specifications in Section 6.

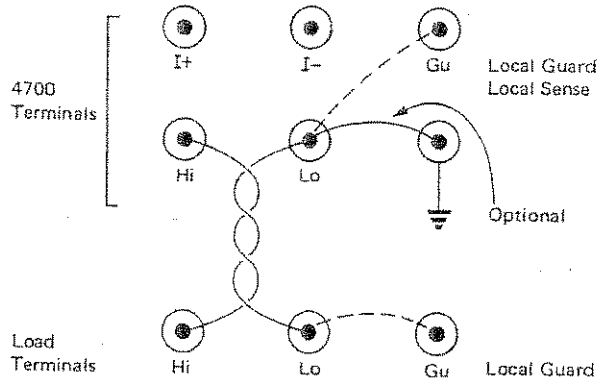

### Screened 2-wire Connection

Use where:

Sensitive measurements are being made.

The E-M environment is relatively 'noisy'.

External common-mode voltages are significant.

Use for measurements in the following ranges:

Voltage	DCV $\geq 10\mu\text{V}$
	ACV $> 90\mu\text{V}$
Frequency	$F \leq 1\text{MHz}$
Resistance	$1\text{k}\Omega \leq R < 1\text{M}\Omega$

After selecting  $\Omega$ , Remote Sense must be cancelled for 2-wire operation.

Select Local Sense and Local Guard.

Keep leads as short as possible, (not longer than 1 meter).

**On 100V/1000V Ranges, Ground the Lo line for Safety.**

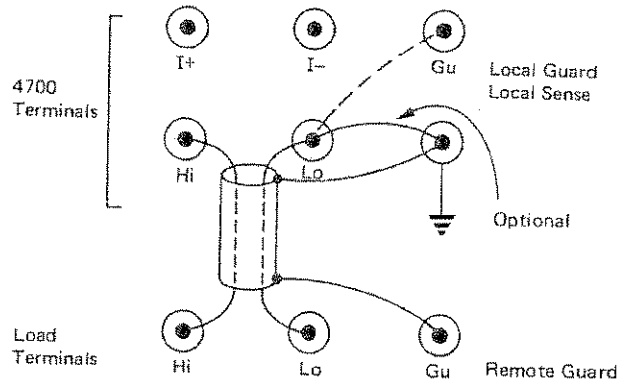

### Screened 4-wire Connection using Coaxial cable.

Use where:

The load resistance is low enough to cause a significant voltage drop in the output connection.

Sensitive measurements are being made.

The E-M environment is relatively noisy.

External common-mode voltages are significant.

Use for measurements in the following ranges:

Voltage	DCV $\geq 90\text{mV}$
	ACV $\geq 90\text{mV}$
Frequency	$F \leq 1\text{MHz}$
Resistance	Not appropriate

Select Remote Sense and Local Guard.

Keep leads as short as possible, (not longer than 1 meter).

**On 100V/1000V Ranges, Ground the Lo line for Safety.**

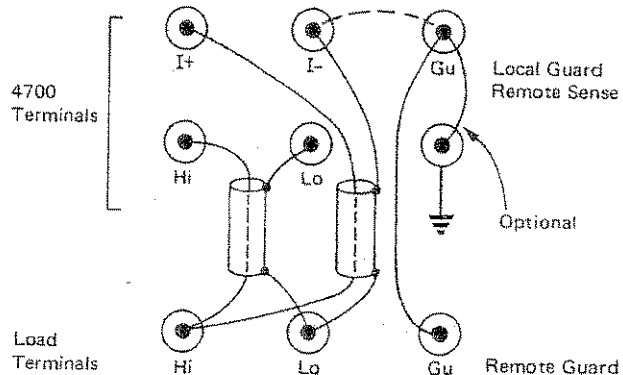

## Operating Routines

The following operating routines are subdivided into two main types:

- Standard Operating Sequences
- Additional Facilities

### Standard Operating Sequences

There are many common elements in the selection routines for both Voltage and Current operation. The diagram opposite shows the general sequence of operations. It should be used as the basis of any operating procedure, in conjunction with the individual selections detailed in the following pages.

### DC Voltage Outputs

There are two overlapping voltage states. The 20V overlap allows  $\pm 10\%$  adjustment about the typical full range value of 100V without changing state.

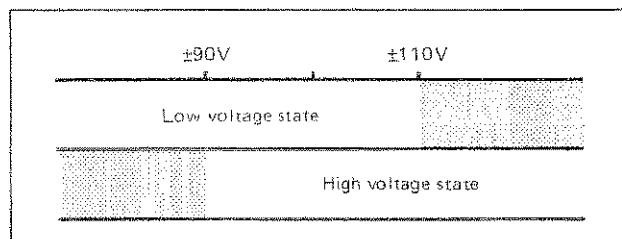

In the Low voltage state, the output may be switched ON directly but to transfer from Low to High Voltage state, deliberate user-actions are required.

N.B. The 4700 switches its output voltage OFF every time the 1000V RANGE is selected and when 1000V RANGE polarity is reversed.

**Low Voltage selections (up to  $\pm 110V$ ).** Use the general sequence:

At operation ③ : Select DC.

At operations ④ and ⑤ : No Remote Sense on 100 $\mu$ , 1m, 10m and 100m ranges

**High Voltage selections (above  $\pm 110V$ ).** Use the general sequence:

At operation ③ : Select DC

At operation ⑨ : RANGE LED flashes for selections above  $\pm 110V$

At operation ⑪ : Audible warning — 5 pulses/sec for 3 secs.

After 3 second warning  
— 4700 switches  
**OUTPUT ON.**

Whilst OUTPUT ON— Audible reminder pulses at approx. 1 sec. intervals, and RANGE LED continues flashing.

If OUTPUT OFF or ON switching is attempted during the 3 sec. delay the 4700 reverts to OUTPUT OFF.

Transfer into High Voltage State with OUTPUT ON

By changing RANGE:

- the OUTPUT is switched OFF, and the selected RANGE LED flashes.

User reselects OUTPUT ON:

- 3 sec audible warning
- 4700 switches OUTPUT ON
- Audible reminder whilst OUTPUT ON
- RANGE LED flashing.

By use of  $\uparrow/\downarrow$  keys in 100V or 1000V range:

- OUTPUT remains ON at previous voltage
- OUTPUT display shows selected (High Voltage) value
- RANGE and OUTPUT ON LEDs flash.

User reselects OUTPUT ON:

- 3 sec audible warning
- 4700 increases OUTPUT voltage to OUTPUT display value
- Audible reminder whilst in High Voltage state
- RANGE LED flashing
- OUTPUT ON LED lit continuously

Transfer out of High Voltage state with OUTPUT ON

By pressing OUTPUT OFF key:

- ON+ or ON— LED remains lit until the OUTPUT Voltage has decayed into Low Voltage State (Approx. 1 sec from 1000V).

By use of  $\uparrow/\downarrow$  keys or by changing RANGE down:

Transfer to Low Voltage State is automatic when the OUTPUT Voltage falls below 90V.

- RANGE LED stops flashing — stays lit
- OUTPUT ON LED stays lit
- Audible reminder is silent.

Changing voltage state when in Error or Offset Mode

For safety reasons, the thresholds are always defined with respect to voltage levels at the OUTPUT terminals. Therefore, if the instrument is in Error or Offset mode, the threshold indications may not coincide with 110V and 90V on the OUTPUT display.

### AC Voltage Outputs

#### Zero Output

Zero AC Voltage output from the 4700 can be obtained only by pressing the Zero key. Internal relay contacts short I+ to I—, and Hi to Lo.



### Increment from Zero

The smallest AC output available on any range is 9% of full range, so any attempt to reduce the output below 9% is refused. Thus the smallest possible increment from Zero is to 10% of full range, using the appropriate key (any key to the right of this would attempt to increment to 1% or less, and be refused, causing 'Error 8' and buzzer to sound). Half-size zeroes on the Zero display show which keys cannot be used to increment from Zero; full-size zeroes show those which can.

When the display is correctly incremented with **OUTPUT ON**, the output terminals are internally reconnected to the voltage output circuitry.

### Zero Displays

Range	Zero Display
1mV	. 0 0 0,0
10mV	0 . 0 0 0,0
100mV	0 0 . 0 0 0,0
1V	. 0 0 0,0 0 0
10V	0 . 0 0 0,0 0
100V	0 0 . 0 0 0,0
1000V	0 0 0 . 0 0 0

### Output Voltage Selection

There are two overlapping AC voltage states. The 15V overlap allows some adjustment without changing state.

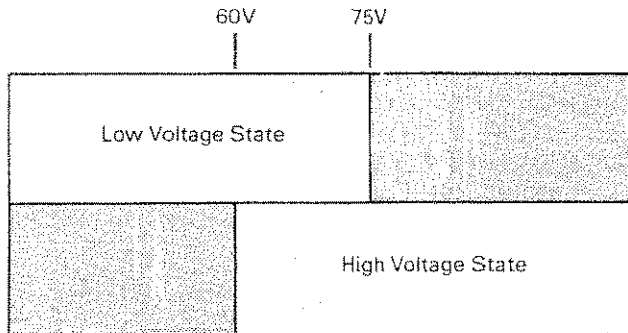

In the Low Voltage state, the output can be switched ON directly, but deliberate user-actions are required to transfer from Low to High Voltage state.

N.B. The 4700 switches its output voltage OFF each time the 1000V RANGE is selected.

### Low Voltage Selections (up to 75V RMS).

Using the general sequence:

At operation (3): Select AC

At operations (4) and (5): No Remote Sense on 1m, 10m and 100m ranges

### High voltage selections (above 75V RMS).

Using the general sequence:

At operation (3): Select AC

At operation (9): **OUTPUT RANGE LED** flashes for selections above 75V RMS.

At operation (11): **Audible warning** — 5 pulses/sec for 3 secs.

After 3 sec. warning: 4700 sets **OUTPUT ON**.

While **OUTPUT** is ON: **Audible reminder pulses** continue at approx. 1 sec. intervals, and **RANGE LED** continues flashing.

If **OUTPUT OFF OR ON** switching is attempted during the 3 sec. delay the 4700 reverts to **OUTPUT OFF**.

### OUTPUT ON Transfers

If **OUTPUT** is already switched ON in Low Voltage State when an attempt is made to select a voltage in excess of 75V RMS, the 4700 safety interlocks prevent the selection. Certain deliberate actions, detailed below, are then required by the operator to effect the selection.

Transfer from Low into High Voltage State, by manual upranging:

- 4700 switches **OUTPUT OFF**,
- Selected **RANGE LED** flashes.
- Operator reselects **OUTPUT ON**:
- 3 sec **audible warning**
- 4700 switches **OUTPUT ON**
- **Audible reminder** while **OUTPUT** is ON
- **RANGE LED** continues flashing.
- **OUTPUT ON LED** lit continuously.

Transfer from Low into High Voltage State, by incrementing the **OUTPUT** display:

- **OUTPUT** remains ON at previous voltage
- **OUTPUT** display shows selected value
- **RANGE** and **OUTPUT ON LEDs** flash.
- Operator reselects **OUTPUT ON**:
- 3 sec **audible warning**
- 4700 increases output voltage to the **OUTPUT** display value
- **Audible reminder** while **OUTPUT** is ON
- **RANGE LED** flashing.
- **OUTPUT ON LED** lit continuously.

Transfer from High into Low Voltage State, by pressing **OUTPUT OFF** key:

- **ON LED** remains lit until the output voltage has decayed (approx. 1 sec from 1kV).

Transfer from High into Low Voltage State, by decrementing the OUTPUT display, or by manual downranging:

- Transfer to Low Voltage State is automatic when the Output Voltage falls below 60V RMS.
- RANGE LED stops flashing — stays lit
- OUTPUT ON LED stays lit
- Audible reminder is silent

#### Changing Voltage State when in Error Mode

For safety reasons, the thresholds are always defined with respect to the voltage at the output terminals. When the instrument is in Error mode the displayed output voltage is modified by the gain error, so the threshold indications may not coincide exactly with 75V and 60V on the OUTPUT display.

#### Frequency Control

Refer to pages 3-6 to 3-8.

## Option 20 Currents and Resistance

#### DC Current

Use the General Sequence:

At operation (3): select DC followed by I

At operations (4) and (5): Remote Sense not available

N.B. Maximum compliance 3V on all ranges.

#### AC Current

#### Zero Output

Zero AC Current output from the 4700 can be obtained by pressing the Zero key. This causes the internal software to isolate the I+ and I- terminals from the internal circuitry, physically interrupting the Output Current.

#### Increment from Zero

The smallest AC output available on any range is 9% of full range, so any attempt to reduce the output below 9% is refused. Thus the smallest possible increment from Zero is to 10% of full range, using the appropriate key (any key to the right of this would attempt to increment to 1% or less, and be refused). Half-size zeroes on the Zero display show which keys cannot be used to increment from Zero; full-size zeroes show those which can.

When the display is correctly incremented with OUTPUT ON, the I+ and I- terminals are internally reconnected to the Current output circuits.

#### Zero Displays

Range	Zero Display
100 $\mu$ A	0 0 . 0 0 0, 0
1mA	0 0 0, 0 0 0
10mA	0 . 0 0 0, 0 0
100mA	0 0 . 0 0 0, 0
1A	. 0 0 0, 0 0 0

#### Current Outputs

To generate AC output currents, use the General Sequence:

At operation (3): select AC followed by I.

At operations (4) and (5): No Remote Sense.

N.B. Maximum compliance 3V on all ranges.

Changing functions switches OUTPUT OFF.

#### Resistance

Use the General Sequence:

At operation (3): Select  $\Omega$  — Remote Sense LED lights as 4700 is forced into 4-wire

At operation (4): If 2-wire Ohms is required, press Remote Sense to deselect

At operation (5): 4-wire Ohms — use I+ and I- terminals for energizing current. Measure at Hi and Lo terminals.

2-wire Ohms — use Hi and Lo terminals.

(I+ and I- terminals internally fused at 1.0A, Hi and Lo terminals fused at 3.75mA; on  $\Omega$  function).

At operation (8): RANGE key value is nominal. OUTPUT display value is as previously calibrated (At Full Range only, for 4-wire; at Full Range and Zero for 2-wire).

At operation (9): Left hand (overrange) pair of  $\uparrow/\downarrow$  keys have the same functions as Full Range/Zero keys. the other  $\uparrow/\downarrow$  keys are inoperative except in Calibration function (See Section 8).

## Additional Facilities

### Frequency Store

#### Store Key

This key controls the storage and recall of five user-selected frequencies. The memories are volatile in that their contents are lost when the 4700 is powered-down. At power-up, the following five decade frequencies are stored automatically:

F1	30Hz
F2	300Hz
F3	3kHz
F4	30kHz
F5	300kHz

### ACCESS TO STORED FREQUENCIES

#### Recall a Stored Frequency

To set the 4700 to one of the five stored frequencies, simply;

- Press and release the **Store** key.
  - Its green LED lights.
- Press and release the desired **F1-F5** key.
  - Its LED lights.
  - The **Store** LED remains lit.
  - The stored frequency is presented on the **FREQUENCY** display, accompanied by its store location (see illustration).

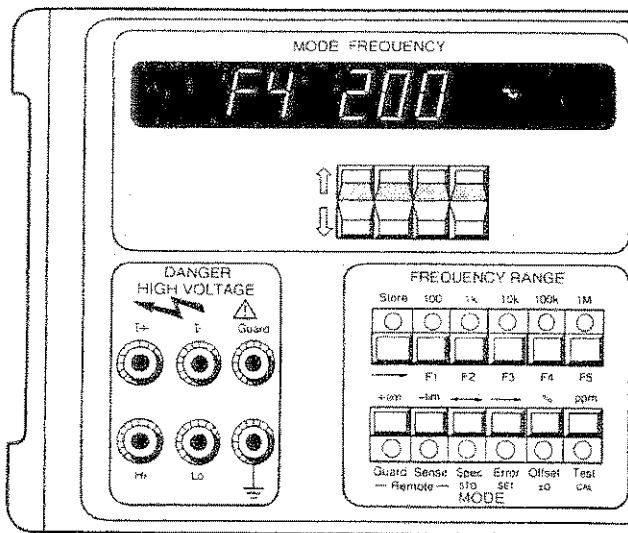

#### Recall from a Different Memory

To switch to a different stored frequency:

- Press and release the desired **F1-F5** key.
  - The displayed indications change as appropriate.

#### Deselect Store

To revert to normal frequency facility:

- Press the **Store** key again.
  - Its LED goes out.
  - The **F1-F5** LED goes out.
  - The stored frequency remains unchanged.

#### Re-program a Frequency Memory Store

To change the Frequency of a Memory Store, the following procedure stores any displayable frequency in any of the five locations:

- Select the required **FREQUENCY RANGE**. Use the **FREQUENCY** display  $\uparrow/\downarrow$  keys to set the new frequency on display.
- Press and hold the **Store** key.
  - Its green LED lights.
- Press and release the desired **F1-F5** key.
  - Its LED lights.
  - The store location is also present on the display.
- Release the **Store** key.
  - Its LED remains lit.
- If desired, deselect **Store** as above.

### STORE KEY — SUMMARY

**Press and Release:** Access **F1-F5** for stored-frequency retrieval.

**Press and Hold:** Allows displayed frequency to be stored in **F1-F5** memories.

#### 'Spec' Mode

##### Spec Key

This key allows a user to avoid constantly referring to the data sheet specifications, when it is necessary to determine the uncertainty for any set value.

#### Uncertainty Data Selection

The range of 4700 specification uncertainties is held in internal memory. **Spec** mode selects the stored data appropriate to the current settings of **Function**, **Range**, **Output Value**, **Frequency** and **Calibration Interval**; then calculates and displays the overall uncertainty.

**Initiation**

To transfer into Spec mode:

Select the required Calibration Interval (Rear Panel switch).

Then follow the sequence in the diagram:

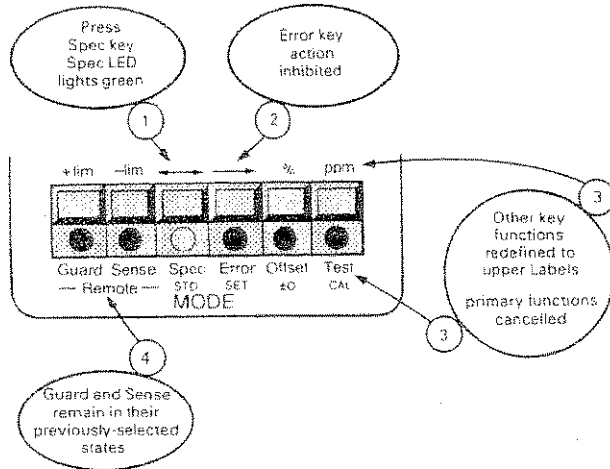

On pressing the Spec key the uncertainty appears on the **MODE** display, displacing the Frequency readout (except for Store, Frequency cannot be changed when in 'Spec' mode). Initially the presentation is as shown in the following table:

Uncertainty	Display Units
≤ 1,999ppm of set value	ppm
> 1,999ppm of set value	%
Not displayable or > 100%	Error 1

**Secondary Spec Modes**

Once the **Spec** key has been pressed, the other **MODE** keys become reassigned to give a choice of four display modes:

ppm, %, +lim, -lim.

**ppm or % Uncertainty** (of displayed value).

From 1ppm to 1999ppm, the uncertainty can be displayed in **ppm**. From 0.001% to 100%, it can be displayed in **%**. When the uncertainty is not defined, the message **Error 1** is displayed and the buzzer sounds.

Example of Error 1 Condition (Any Cal interval)

Output range	IV
Setting	Zero key pressed.
Frequency	Any frequency.
Uncertainty	Not defined at Zero.
Mode display is	<b>Error 1</b> .

**+Lim or -Lim**

To obtain a reading of an absolute limit of uncertainty:

Press the **+Lim** or **-Lim** key.

The **MODE** display will switch to the same resolution as the **OUTPUT** display and its reading will be the positive or negative absolute limit of uncertainty (i.e. the **OUTPUT** reading plus or minus the absolute uncertainty error limit for that output).

As the reading approaches full scale, its positive limit may exceed full scale. If **+lim** is selected, **Error 1** is displayed and the buzzer sounds.

**FUNCTION and RANGE Control in Spec Mode**

The **FUNCTION**, **OUTPUT RANGE** and **OUTPUT**  $\uparrow/\downarrow$  keys can be operated normally. The 4700 will adjust its **MODE** display to the uncertainty figure appropriate to each new selection.

**FREQUENCY Selection in Spec Mode**

The **MODE/FREQUENCY** display is assigned to its 'Uncertainty' presentation. Consequently the use of the **FREQUENCY RANGE**, **FREQUENCY**  $\uparrow/\downarrow$  and **Store** keys is inhibited.

Nevertheless, by pressing the **Store** key followed by one of the **F1-F5** keys **BEFORE** pressing **Spec**, all five 'Stored' frequencies can still be accessed.

In this case the **MODE** display normally presents the appropriate uncertainty figure. But a readout of the Stored frequency can be obtained by merely pressing and releasing the **F1-F5** key whose **LED** is lit. The store location and frequency will appear for about 1 second, before changing back to the uncertainty figure.

**4700 'Spec' Data**

Section 6 breaks down the specification into:

- a) Stability
- b) Accuracy relative to Standards
- c) Datron's Calibration Uncertainty.

The **CALIBRATION INTERVAL** switch on the rear panel is labelled:

**24hr, 90dy, and 1yr.**

The stored uncertainty data is selected from (b) and (c) above, as follows:

- 24hr : (b),  $23^{\circ}\text{C} \pm 1^{\circ}\text{C}$
- 90dy : (b) + (c),  $23^{\circ}\text{C} \pm 1^{\circ}\text{C}$
- 1yr : (b) + (c),  $23^{\circ}\text{C} \pm 10^{\circ}\text{C}$

Thus the accuracy figures displayed for 90dy and 1yr are traceable to National Standards.

In verifying the instrument's specification on receipt of a 4700, users are able to display the 90-day limits to check against the instrument's specified traceable accuracy. After recalibration, the '24 hour interval' limits should be used to verify against the same standards used for calibration.

Refer to Section 7, Specification Verification, for further information.

### 'Error' and 'Offset' Modes

(Voltage and Current Only)

The specification of a high accuracy DMM (and of other electrical measuring equipment) relates its display readings to its input values. A perfectly calibrated DMM would have an exact 1:1 correspondence, and the specification lays down acceptable tolerances of deviation from this direct relationship. Plotted as a graph, the ideal case is a straight line at  $45^{\circ}$  through the origin. The tolerances, plotted on the graph, enclose an area on both sides of this line.

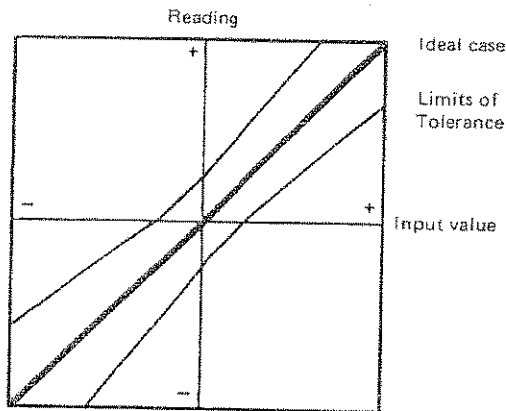

There are three major causes of deviation from the ideal case:

- Zero offset** — the line does not pass through the origin. Most DMMs have a front panel adjustment to correct this.
- Gain error** — the slope of the line is not  $45^{\circ}$

**Linearity error** — the slope of the line varies. (A common variation is a "dog's leg" at zero).

Each of these elements could cause large enough deviations to place the instrument out of tolerance, sometimes a combination of elements being responsible.

The "Error" and "Offset" modes allow a user to deviate the output of the 4700 in specific ways, so as to identify directly the causes of excessive deviation.

### Error Key

The Error key is used to initiate Error mode. The 4700 terminal value can then be deviated from the **OUTPUT** display value, by known gain factors, as entered on the **MODE display**.

### Error Mode Display

Pressing the Error key changes the **MODE/FREQUENCY** display from 'Frequency' readout to 'Error Mode' readout. The initial reading is always '0.0 ppm', indicating that the terminal value has not yet been deviated.

### MODE/FREQUENCY $\uparrow/\downarrow$ Keys

The terminal value is changed, without altering the **OUTPUT** display, by pressing the  $\uparrow/\downarrow$  keys beneath the **MODE/FREQUENCY** display. The gain compensation being applied is displayed as a **percentage** or **ppm** of the **OUTPUT** display value; with positive polarity for an increase of terminal value, and negative for a decrease.

The gain-compensation factor has a maximum possible resolution of  $\pm 0.1\text{ppm}$  of Full Range (DCV).

### Example of the use of "Error" mode

To measure the linearity of a DMM, a user needs to:

- Remove any zero offset.
- Detect and measure any inherent gain error ratio (usually from its response to a full range input).

Calculate compensating deviations for each of the inputs for the linearity measurement, based on the measured ratio,

and

- Compensate each input to the DMM so that the linearity errors may be measured.

In "Error" mode, once the gain error has been measured, the 4700 automatically calculates and

applies the compensating deviation to all its outputs on that range and function; whilst displaying both the nominal (uncompensated) value of output and the compensation ratio. Only if the DMM response is linear, will each DMM reading agree with the corresponding 4700 OUTPUT display value.

In the following sequence a DMM is checked for linearity. For purposes of explanation, it is assumed that linearity is correct, but the DMM has a gain error of +100.0 ppm.

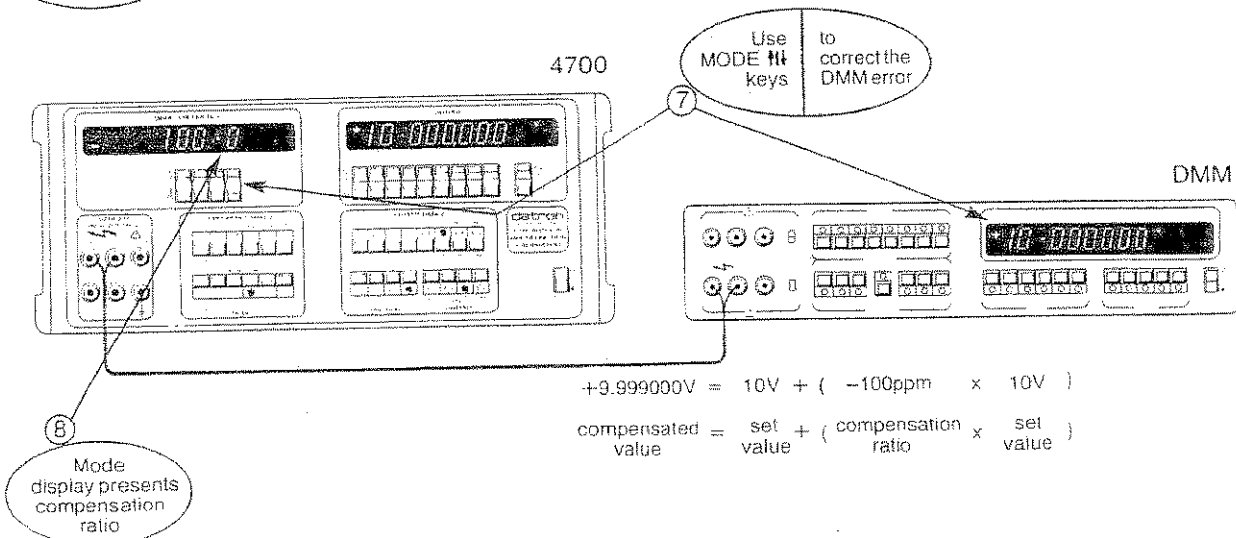
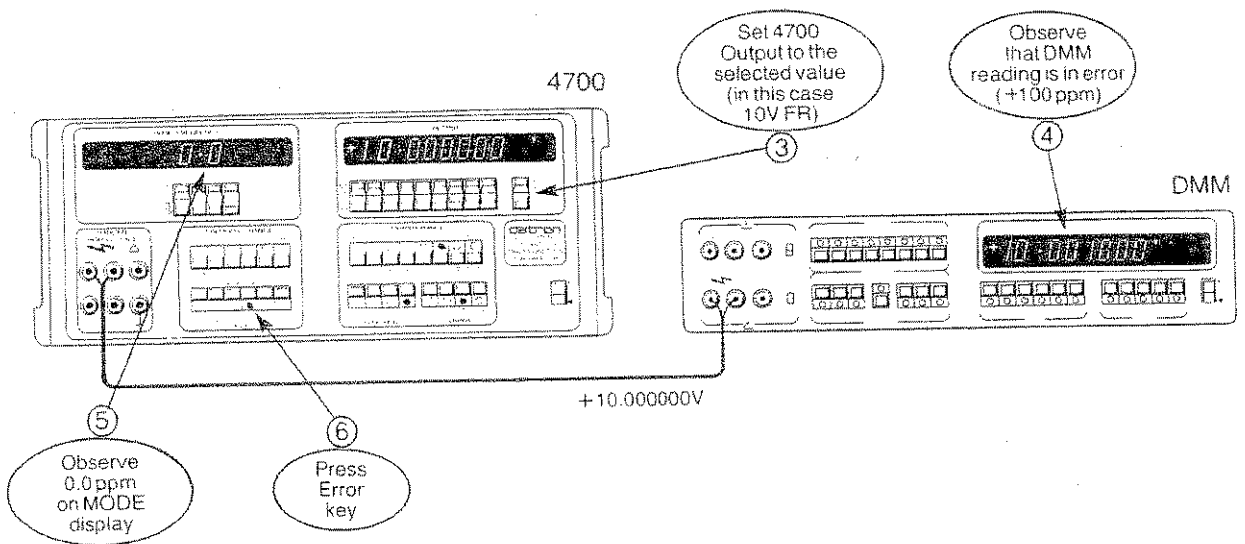
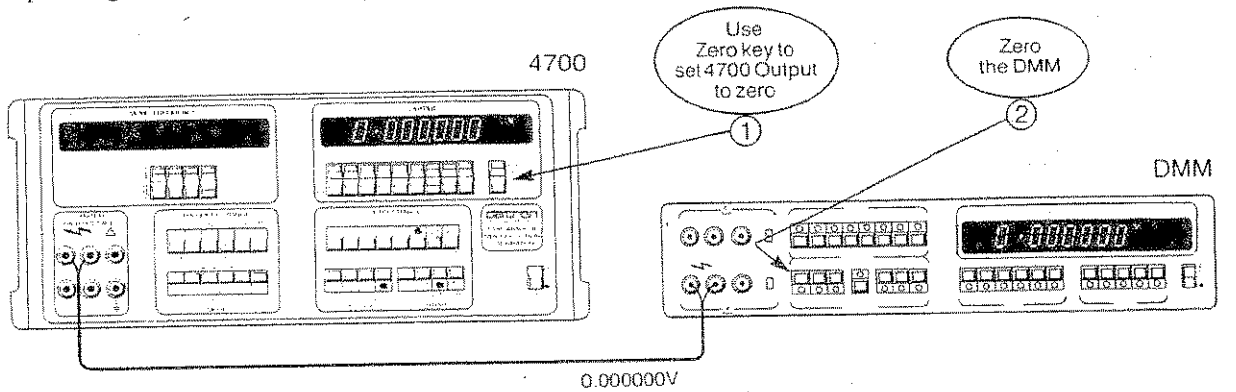

The 4700 output has now been compensated for the gain error of the DMM. All selected output values will be compensated in the same ratio on this range and function until either the ratio is changed or Error mode is deselected. The **Mode** display presents the compensation ratio directly. Note that the compensation polarity is shown, not the error polarity, therefore the true output is the sum of both displayed values; in this case  $+10.000000V - 100\text{ppm} = +9.999000V$ .

The linearity of the DMM may now be checked by directly comparing its reading with the **OUTPUT** display settings.

e.g. at +5V on this range, both 4700 and DMM read +5.000000V, although the terminal voltages are +4.995000V

Other linearity check values could be:

Nominal Check Point	4700 set Value	DMM Reading	Terminal Voltages
-0.5V	-0.500000V	-0.500000V	-0.499950V
+0.1V	+0.100000V	+0.100000V	+0.099990V
+0.01V	+0.010000V	+0.010000V	+0.009999V

**Full Scale Limiting.** The **OUTPUT** display cannot be raised to a value which sets its overrange digit to greater than 1, and the **Error MODE** display cannot be raised above  $\pm 9.9999\%$  ( $\pm 999.9$  ppm).

Nevertheless, a combination of **OUTPUT** display value and **gain error** could result in an off-scale value. The 4700 prevents this by rejecting any demand for an error-corrected Output Voltage in excess of full scale. The user is informed by **Error 5** message on the **MODE** display with no change to the **OUTPUT** display.

**Deselection of Error Mode** clears the **MODE** display, turns the green **Error LED OFF** and restores the 4700 gain factor to unity. Normally the mode is deselected by repressing the **Error** key, but it is also turned off by changing **FUNCTION** or **RANGE**.

## 'Offset' Mode (DC Functions only)

### Offset key

A device being checked against the 4700 (say a DMM) may have an inherent zero offset error. Nevertheless, a user may wish to perform other measurements before removing the offset error. The 4700 "Offset" Mode is used for this purpose.

**N.B.** The **MODE**  $\uparrow/\downarrow$  keys have an automatic action: If a key is held pressed, the display will increment or decrement continuously until the key is released.

The value of output at the 4700 terminals is now the **sum** of the **OUTPUT** display value and the **MODE** display offset value.

The following example generates an offset of  $-100\mu V$  on the 10V range of a DMM, for all set values (unless the 4700 would be driven off-scale).

Connect the DMM to the 4700, both set to 10V range, ensuring that 4700 **Error** and **Offset** LEDs are **UNLIT**.

Note that the negative polarity of the Offset value shown on the **MODE** display indicates that the Output voltage is more negative than the value on the **OUTPUT** display, i.e. the 4700 offset polarity is displayed, not the polarity of the DMM offset error.

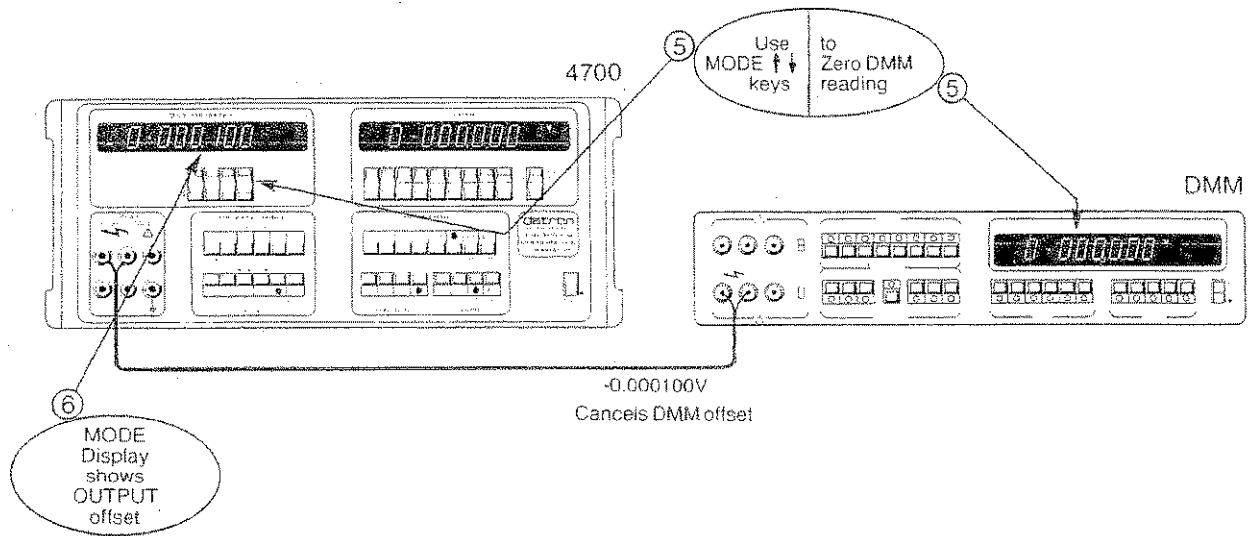
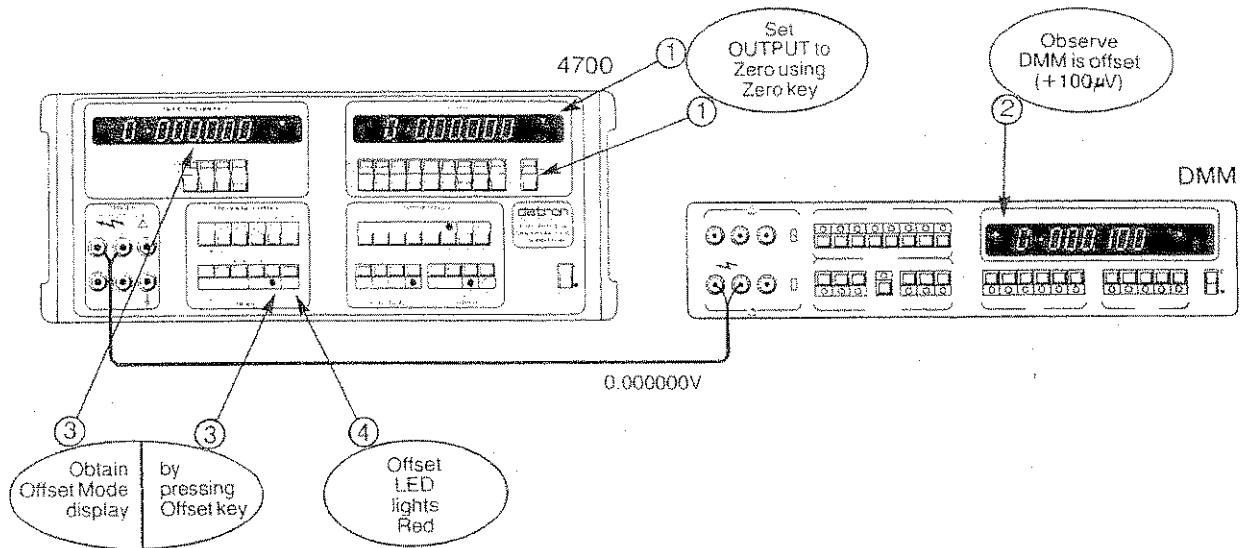

Now the DMM gain error only may be measured:

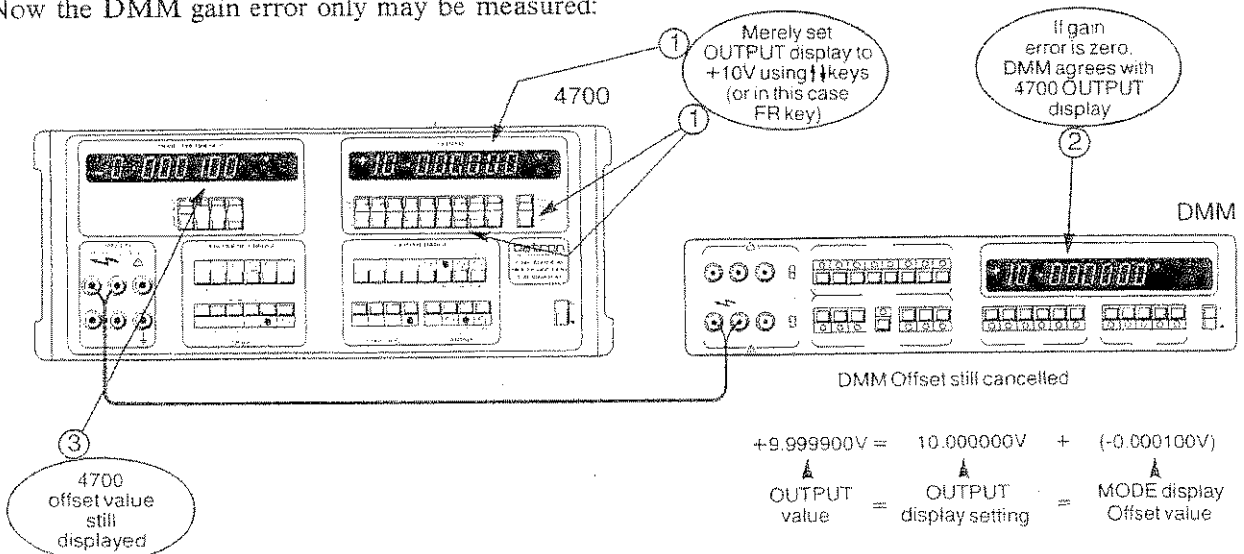



**Full Scale Limiting.** The 4700 will reject any combination of set value and zero offset which would result in an off-scale output.

e.g. if  $-19.999950V$  is set together with  $-100\mu V$  offset, the user is requesting an offscale output of  $-20.000050V$  and the combination is invalid. The 4700 causes **Error 5** to appear on the **MODE** display as a signal to the user, and continues to output its previous (valid) value.

The **OUTPUT display** cannot be set to a value greater than Full Scale. The **Offset MODE display** cannot be set to a value greater than the Offset span for the Range in use.

i.e.  $100\mu V$  and  $1mV$  Ranges:  $<200\mu V$   
Other Ranges:  $<2\%$  of Full Range value

**Deselection of Offset Mode** clears the **MODE** display, turns the red **Offset LED OFF** and reduces the 4700 offset to zero. Normally the mode is deselected by repressing the **Offset** key, but it is also turned off by changing **FUNCTION** or **RANGE**.

#### Combining Offset and Error modes (DC Functions only)

By combining Offset and Error modes it is possible to carry out a rapid analysis of a measuring instrument's linearity (e.g. for a DMM or A-D converter) without the need to correct its zero offset and gain errors.

This is done by using **Offset Mode** to compensate the 4700 output for the DMM's zero offset, and then using **Error Mode** to compensate for the DMM's gain error with the offset compensation still present.

In this condition, any residual deviations in DMM readings from the 4700 **OUTPUT display** settings represent non-linearities which would still be present if the DMM were corrected for offset and gain errors.

This facility also permits a user to quantify the linear response of the instrument to its input values in the form  $y = mx + c$

in which  $y$  = instrument reading  
 $x$  = input value  
 $m$  = gain ratio  
 $c$  = zero offset value

e.g. for a DMM on its  $10V$  range:

if  $y = 9.999956x - 0.000084$ ,  
then the DMM needs a gain compensation of  $+4.4ppm$  and a zero offset compensation of  $+84\mu V$

These compensation figures can be read directly from the 4700 **MODE display**, during the following procedure.

Combination procedure (See Note below)

1. Use Offset-mode to compensate for input offset error and record the 4700 **MODE display value** at operation **6**  $\rightarrow$  ( $\gamma$ ) on page 4-13.
2. With Offset LED still lit, press **Error** key. Use Error mode to compensate for the instrument's gain error and record the 4700 **MODE display value** (ppm or %) at operation **8**  $\rightarrow$  ( $\mu$ ) on page 4-13.
3. Use suitable values of **OUTPUT display setting** to check the linearity of the instrument under test. If the instrument has perfect linear response, then its readings will agree with those of the 4700 **OUTPUT display** and its linear transfer function is:

either: Instrument reading

$$= \left[ 1 - \frac{\mu \text{ (in ppm)}}{10^6} \right] \times \text{Input value} - \gamma \equiv y = mx + c$$

or:

$$= \left[ 1 - \frac{\mu \text{ (in \%)}}{100} \right] \times \text{Input value} - \gamma \equiv y = mx + c$$

4. Deselect in reverse sequence.

**NOTE:** For these equations to be valid, the procedure must follow the above sequence. Therefore the 4700 has been designed to inhibit any other sequence.

i.e. Offset mode cannot be selected or deselected when the Error LED is lit, and the Offset key operates in its secondary function of '%'.

#### Test Key

##### Tests available

There are two stages of 'Test' mode. The first stage, Safety and Memory checks, cannot be omitted from any 'Test' sequence.

### Safety and Memory Checks

On first pressing the **Test** key, the 4700 carries out three checks:

1. Operation of the Safety trip, buzzer and reset circuitry.
2. Calibration Memory integrity.
3. Over-voltage check. (High voltage when not in HV state).

Messages appear on the **MODE** display, and completion is signalled by the **Test LED** going **OFF**. The second stage Display and Key checks may be omitted by pressing any key **other than Test**.

### Display and Key Checks

If the **Test Key** is re-pressed before pressing any other key, a visual sequence tests the front panel:

1. Gas discharge displays.
2. Key LEDs.
3. Key contacts (user-selected).

The 4700 remains in the key-contact mode until the **Zero Key** is pressed or test is deselected. It may then be used normally.

- N.B.**
1. At any time during the second stage, the Test sequence may be aborted by pressing **Test Key** again.
  2. During self-test the instrument reset facility is not available.

### Test Sequence

The Front or Rear panel terminals are not energized during Test sequence.

### Safety and Memory Checks

#### 1. Initial Conditions

Ensure that **OUTPUT OFF LED** is lit, **Error** and **Spec LEDs** are unlit. Check that **Test LED** is unlit.

#### 2. Press Test Key:

**Test LED** lights as the checks begin.

#### 3. Safety Trip Check

The 4700 tests the safety trip circuits. The **SAFETy** message appears on the **MODE** display and the buzzer will sound continuously when the trips have operated, and the **Reset LED** flashes.

#### 4. Reset Check

The program ensures that user tests the **Reset** action.

#### Press Reset Key:

The **SAFETy** message is replaced by the **running** message and the buzzer stops sounding. Relay operation can be heard during the automatic checks which follow.

#### 5. Calibration Memory Check

This is a sum-check of the Non-volatile RAM. If the check fails, the Message **FAIL 6** appears, otherwise no message.

#### 6. Over-Voltage Checks

The 4700 automatically tests the over-voltage detector threshold levels in Low Voltage state.

If the check fails, the message **Fail 2** appears, otherwise **PASS** message indicates both tests completed successfully.

#### 7. The Test LED goes OFF.

The following table summarizes the **MODE** display messages:

Message	Reason
<b>SAFETy running</b>	First stage of 'test' operative.
<b>PASS</b>	No failure discovered.
<b>FAIL 6 only</b>	Parity error in Calibration Memory check.
<b>FAIL 2 only</b>	High voltage can be present in Low Voltage state.

Any combination of these two **FAIL** messages can appear in sequence, replacing the **running** message.

8. To terminate **Test** before the Display and Key checks, press any key **other than Test**:  
**4700** returns to prior conditions.

**Display and Key Checks.**

**Visual Check Sequence** Read this Note before pressing Test Key to start.

**NOTE:** After pressing Test Key, the Visual Check sequence commences. During this sequence observe that:

- (a) No display segments or blocks are missing or incomplete.
- (b) Segments and blocks do not appear spuriously.
- (c) Inter-digit and inter-segment 'streaming' does not occur.
- (d) All LEDs are lit in their correct sequence.
- (e) LEDs are not lit spuriously.

1. Press Test key — Test LED lights  
 — All other LEDs unlit  
 — Displays cleared momentarily,  
 then:

2. **MODE** Display  
 (a) Initial presentation:

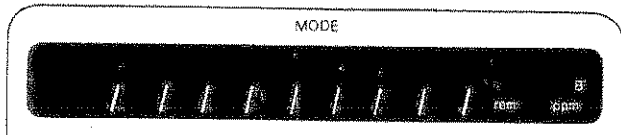

Nine segments and legends are presented.

(b) Progressively, all seven-segment digits and legends are displayed segment by segment.

**N.B.** Commas are presented in the **MODE** display sequence.

(c) **MODE** display cleared.

3. **OUTPUT** Display  
 (a) Initial presentation:

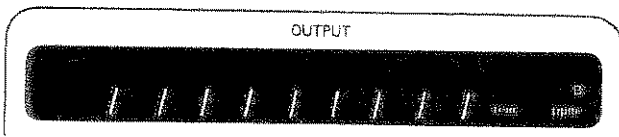

Nine segments and legends are presented.

(b) Progressively, all seven-segment digits and legends are displayed segment by segment.

(c) Final presentation: Nine commas are displayed on **OUTPUT** display then all 18 commas are displayed on **OUTPUT** and **MODE** displays.

(d) **OUTPUT** and **MODE** displays cleared.

4. **MODE** Display

(a) Initial presentation:

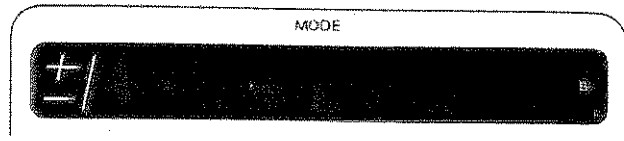

Polarity signs and overrange digit displayed.

(b) Progressively, seven-segment digits are presented digit by digit.

(c) Final presentation.

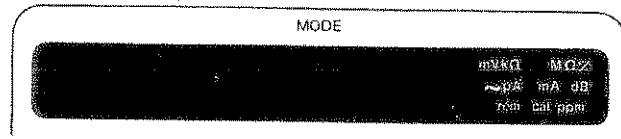

First, then second blocks of legends are displayed.

(d) **MODE** display cleared.

5. **OUTPUT** display digits are presented next, in the same order as for the **MODE** display.

6. **LED** Check sequence commences:

(a) Test LED stays on, and other key LEDs are lit in Left to Right sequence starting at  $100\mu$  key and ending at OFF.

(b) **MODE** display.

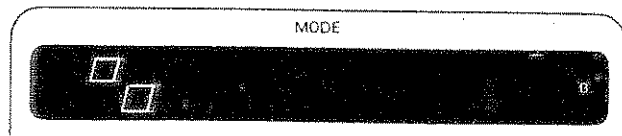

Symbol shown indicates that the keys are ready to be checked.

## 7. Key Checks

N.B. The **Zero** key should not be pressed until it is desired to terminate the Test Sequence.

(a) **↑|↓ Keys**

Each **↑** key should light the upper half of the digit immediately above it.

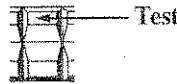

OUTPUT Display overrrange digit **↑** key.

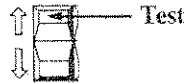

Each **↓** key should light the lower half of the digit immediately above it.

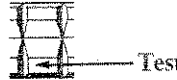

OUTPUT Display overrrange digit **↓** key.

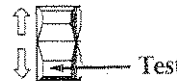

(b) **FREQUENCY RANGE, MODE, OUTPUT RANGE, FUNCTION** and **OUTPUT** keys should cause their LEDs to light, except:

- (i) **Reset** key, which is inoperative,
- and (ii) **Test** key, which aborts the test.

In these tests the key-press operates a latch so that the display or LED remains lit until another key is pressed. Only one key-press at a time is recognized.

(c) **To Terminate the Test Sequence:**

- Press **Zero** key to check its operation.
- 4700 reverts to initial conditions.
- **Test** LED goes **OFF**

(d) Operate 4700 normally.

## Warnings and Messages

### High Pitch Audible Warning

- (a) Sounds at approx 5 pulses per second during the 3 second delay between selection of **OUTPUT ON** and the High Voltage being connected to the terminals, when the **OUTPUT TERMINAL VOLTAGE WILL EXCEED 110V DC or 75V RMS.**
- (b) Sounds at approx 1 second intervals with **OUTPUT ON** in **High Voltage State.**
- (c) Sounds for 1 second with blank **FREQUENCY** display when frequency auto-ranges up or down.
- (d) Sounds continuously when **SAFETY** message is present on **MODE** display during self test.

### Low Pitch Audible Warning

- (a) Sounds when any message is displayed on the **MODE/FREQUENCY** display (except recalled messages).
- (b) Sounds when any invalid bus command is received.

### FREQUENCY/MODE display

- |          |                                    |  |
|----------|------------------------------------|--|
| Error 1  | — Spec Mode: [%]<br>; [+Lim, -Lim] | — Tolerance exceeds 100%.<br>— The selected limit is off-scale.  |
| Error 2  | — Calibrate Mode                   | — <b>OUTPUT OFF.</b>   |
| Error 3  | — Calibrate Mode                   | — Incorrect. <b>FUNCTION, OUTPUT</b> or <b>FREQUENCY RANGE</b> for this calibration mode.  |
| Error 4  | — Calibrate Mode                   | — Correction out of limits.  |
| Error 5  | — Offset or<br>Error Mode          | — Temporary message. The selected deviation would exceed the full-scale value. <b>Activation has been prevented.</b>                           |
| Error 6  | — Calibrate Mode<br>(Resistance)   | — The resistance value selected exceeds the calibration value.   |
| Error 7  | — 100V and<br>1000V Ranges         | — Temporary message. The selected Voltage and Frequency exceeds the 4700 internal constraints. <b>Activation has been prevented.</b>           |
| Error 8  | — Selection error                  | — Temporary message. The operation requested by the user is not possible in present machine configuration.                                     |
| Error 9  | — Option not fitted                | — Temporary message. The requested range or function option is not fitted.   |
| Error EF | — External frequency               | — The external frequency is not present, machine will perform out of specification.  |
| Error OL | — Voltage Ranges                   | — The output has been <b>current-limited</b> by an overload. (If in 100V or 1000V range, <b>OUTPUT</b> is automatically switched <b>OFF</b> ). |
|          | — Current Ranges                   | — The terminal voltage has been <b>compliance-limited</b> to 3V. (Load impedance too high)   |

- |        |   |        |   |
|--------|---|--------|---|
| FAIL 1 | — Excessive internal temperature.         | FAIL 7 | — 400V power supply fault – this 'trip' may reset itself if no hardware fault exists and the Fail message is temporary. |
| FAIL 2 | — Over-voltage                            | FAIL 8 | — 38V power supply fault.   |
| FAIL 3 | — Control data corrupted.                 | FAIL 9 | — 15V in-guard power supply fault.  |
| FAIL 4 | — Precision divider fault.                |        |   |
| FAIL 5 | — Safety circuits tripped.                |        |   |
| FAIL 6 | — Calibration memory sumcheck non-parity. |        |   |

- SAFETY** — Test Mode — Safety circuits tested by tripping: Press **Reset** key to continue test.  
**running** — Test Mode — Indicates test in progress.  
**PASS** — Test Mode — **FAIL 6** did not occur during test of calibration memory parity, and **FAIL 2** did not occur during test of over-voltage thresholds.

### Recalled Messages

- ISS XX.XX** — Firmware issue number (selected by pressing **Error** then **-Lim**).  
**Addr XX** — IEEE 488 Bus address as set on Address switch (selected by pressing **Error** then **+Lim**).

**Processor 'Busy' (Keyboard Unreceptive)**

The 4700 will not respond to commands while legend 'B' is present on the **MODE** and **OUTPUT** displays except to override during safety delay.

**KEY LEDs**

**Basic Indications:**

- Lit** — The labelled facility is selected and active.
- Unlit** — The labelled facility is not selected.
- Lit Green (Spec and Error only)** — Other **MODE** keys' facilities are reassigned to the secondary modes printed **ABOVE** their keys, as directed by the arrows
- Lit Green (Store only)** — **FREQUENCY RANGE** keys are reassigned to select **F1-F5** memory stores.

**Warnings with Function DC or AC Selected:**

- OUTPUT RANGE 100V or 1000V LED flashing**
  - A voltage in excess of **110V DC** or **75V RMS** has been selected (**OUTPUT ON** or **OFF**).
- ON LED flashing while in Low Voltage State with OUTPUT ON**
  - An attempt to select output in excess of **110V DC** or **75V RMS** has been prevented.
  - Reprising **OUTPUT ON** key will switch the **HIGH VOLTAGE ON**.



# DANGER HIGH VOLTAGE

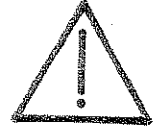

**THIS INSTRUMENT IS CAPABLE  
OF DELIVERING  
A LETHAL ELECTRIC SHOCK!**



FRONT or REAR  
terminals carry the  
Full Output Voltage.

**THIS CAN KILL!**



Guard terminal is  
sensitive to over-  
voltage

**It can damage  
your instrument!**

Unless **you** are **sure** that  
it is **safe** to do so,  
**DO NOT TOUCH** the  
**I+ I- Hi or Lo leads**  
and **terminals**

# DANGER

# SECTION 5 SYSTEMS APPLICATION VIA THE IEEE 488 INTERFACE

## Introduction

Section 5 gives the information necessary to put the 4700 into operation on the IEEE 488 bus. As some operators will be first-time users of the bus, the text is pitched at an introductory level. For more detailed information, refer to the standard specification, which appears in the publication ANSI/IEEE Std. 488-1978.

### Section Contents

The section is divided so as to group certain types of information together. These divisions are:

**Interface Capability** — the permitted options which have been implemented in the 4700.

**Typical System** — a brief view of a typical process using the 4700 to check a DMM calibration.

**Using the 4700 in a System** — implications of bus operation.

**Programming Instructions** — how the 4700 facilities have been transferred into remote commands.

**Programming of Operational Functions** — more detail about the codes which control 4700 operation.

**Programming of Bus Transmissions** — how to program the 4700 to obtain specific types of readout.

**Service Request** — why the 4700 needs the controller's attention and how it gets it.

**Activation of Commands** — what the 4700 does with the commands it receives.

**Operational Sequence Guidelines** — a little general help with programming sequences.

## INTERFACE CAPABILITY

### IEEE Standard 488

The 4700 conforms to the Standard specification IEEE 488-1978 — 'IEEE Standard Digital Interface for Programmable Instrumentation'.

It can be connected to the IEEE 488 Interface Bus and set into programmed communication with other

bus-connected devices under the direction of a system controller.

### Programming Options

The instrument can be programmed via the IEEE Interface, to:

- (1) Change its operational state (Range, Function, Frequency, Mode, Output, etc).
- (2) Transmit its own status data to other devices on the bus.
- (3) Request service from the system controller.

### Capability Codes

To conform to the standard specification, it is not essential for a compatible device to encompass the full range of bus capabilities.

The IEEE 488 document describes and codes each of the standard bus features, so that manufacturers can provide brief coded descriptions of their own interfaces' overall capability. A code string is often printed on the product itself.

The codes which apply to the 4700 are given in Table 5.1, together with short descriptions. They also appear on the rear of the instrument next to the interface connector.

Appendix C of the IEEE 488 document contains a fuller description of each code.

Code	Interface Function
SH1	Source Handshake Capability
AH1	Acceptor Handshake Capability
T6	Talker (basic talker, serial poll, unaddressed to talk if addressed to listen)
TE $\emptyset$	No Address Extension Talker Mode
L4	Listener (basic listener, unaddressed to listen if addressed to talk)
LE $\emptyset$	No Address Extension Listener Mode
SR1	Service Request Capability
RL2	Remote/Local Capability (without Local Lockout)
PP $\emptyset$	No Parallel Poll Capability
DC1	Device Clear Capability
DT $\emptyset$	No Device Trigger Capability
C $\emptyset$	No Controller Capability
E1	Open-Collector Drivers

Table 5.1 IEEE Interface Capability.



### Bus Addresses

When an IEEE 488 system comprises several instruments, a unique 'Address' should be assigned to each to enable the controller to communicate with them individually.

One address is sufficient for a Datron instrument, as the controller can add information to it to define either 'talk' or 'listen'.

### Interconnections

Instruments fitted with an IEEE 488 interface normally communicate through a set of interconnecting cables, specified in the IEEE 488-1978 Standard document.

The 4700's interface connector, J27, is fitted on its rear panel. It receives the specified connector, whose pin designations are also standardized and shown in Fig. 5.1 and Table 5.2.

Fig. 5.1 J27 Pin Layout

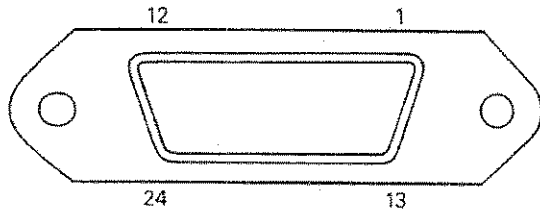

J27 Pin No	Name	Description
1	DIO 1	Data Input Output Line 1
2	DIO 2	Data Input Output Line 2
3	DIO 3	Data Input Output Line 3
4	DIO 4	Data Input Output Line 4
5	EOI	End or Identify
6	DAV	Data Valid
7	NRFD	Not ready for Data
8	NDAC	Not Data Accepted
9	IFC	Interface Clear
10	SRQ	Service Request
11	ATN	Attention
12	SHIELD	Screening on cable (connected to Safety Ground)
13	DIO 5	Data Input Output Line 5
14	DIO 6	Data Input Output Line 6
15	DIO 7	Data Input Output Line 7
16	DIO 8	Data Input Output Line 8
17	REN	Remote Enable
18	GND 6	Gnd wire of twisted pair with DAV
19	GND 7	Gnd wire of twisted pair with NRFD
20	GND 8	Gnd wire of twisted pair with NDAC
21	GND 9	Gnd wire of twisted pair with IFC
22	GND 10	Gnd wire of twisted pair with SRQ
23	GND 11	Gnd wire of twisted pair with ATN
24	GND	4700 Logic Ground (Internally connected to 4700 Safety Ground)

Table 5.2 IEEE 488-1978 Connector - Pin Designations

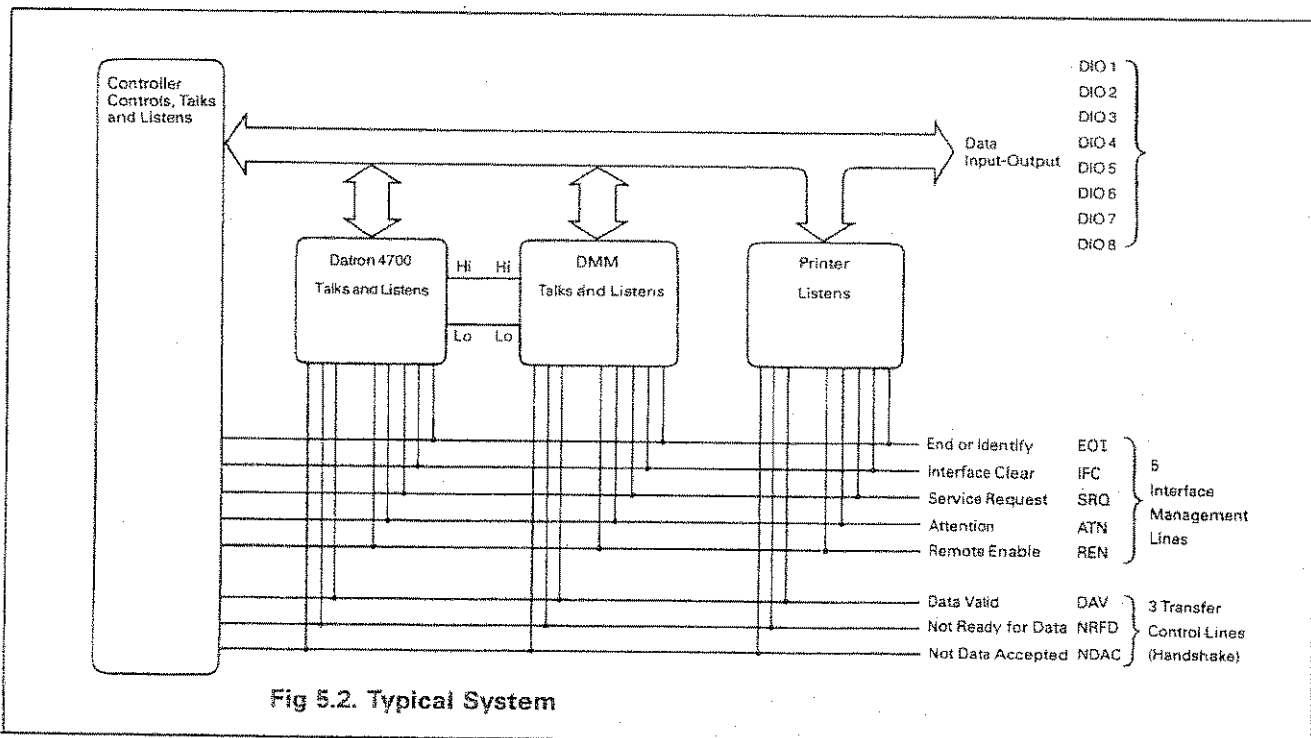

Fig 5.2. Typical System

## Typical System

A typical system is shown in Fig. 5.2. The system is directed by a controlling device able to:

- (a) 'Control' (Issue commands)
  - (b) 'Listen' (Receive data)
- and (c) 'Talk' (Transmit data)

### EXAMPLE OF A SYSTEM IN OPERATION

In the system example (Fig. 5.2) the programme task could be to check the DMM calibration against the 4700, and print out the results. The following is a typical sequence of events:

- (1) The controller needs to instruct the 4700 to set its output to a calibration point for the DMM. These commands must not be received by the DMM or the printer and so the controller sends the general bus message 'Unlisten'. When sending general messages, the controller makes all bus devices interpret any DIO-line data as configuration or data-flow commands, by holding the ATN line true.
- (2) The controller then sends the 4700's listen address to force it to receive, followed by 4700 configuration commands (including the **Output Disable** message, to prevent the DMM receiving an inappropriate analog input). The instructions are passed along the DIO (data input-output) lines as coded messages (bytes). The code used is ASCII (American Std. Code for Information Interchange).
- (3) Although the 4700 accepts the instructions as they are passed, their implementation takes a short time. The controller would perform other tasks during this period. In the example, it would pass configuring commands to the DMM, after 'Unlisten' and the DMM listen address have been sent.
- (4) The DMM also needs time to settle into stable operation, so the controller performs other tasks while waiting, such as configuring the printer.
- (5) The controller next generates 'Unlisten', addresses the 4700 as listener, and re-configures its Analog Output On by an **Output Enable** message. If the 4700 has executed its previous instructions, it sets OUTPUT ON immediately, otherwise the OUTPUT is set ON as soon as they have been executed. In either case, the instrument sends a message back to the controller via the SRQ (Service Request) management line, if programmed to do so.
- (6) As the SRQ facility is available to all bus devices (Wired-OR function), the controller needs to discover which one sent the 'SRQ'. It therefore asks all devices one by one ('serial poll'), finds out that the 4700 is the SRQ source and that its OUTPUT is ON.
- (7) It next addresses the DMM as a listener, and sends the GET message (Group Execute Trigger) via the DIO lines to initiate the reading. After a short delay for measurement, the DMM prepares output data and SRQ's the controller when it is ready for transfer.
- (8) The controller identifies the DMM by a serial poll. Finding that the reading is available, it sends the DMM's talk address, and printer's listen address, to activate both devices.
- (9) The controller sets the ATN line false, thus releasing both devices to start the transfer. The DMM sends its data, byte by byte, via the DIO lines to the printer. This data must be in a form acceptable to the printer, and to ensure orderly transfer, each byte is transferred by 'Handshake', using the three Transfer-Control lines.
- (10) Usually the controller is also listening to this data transfer to determine when it is complete. As an aid to the controller and printer, the DMM can send another message with the last byte to be transferred (EOI-end or identify, using another bus management line).
- (11) The sequence is complete, and the controller can start again at another calibration point.

The controller holds the REN line true when taking remote control. It can send an addressed command GTL, or some controllers can set REN false, to permit temporary manual control of a device. The IFC line is used at the discretion of the controller, to clear any activity off the bus.

Sequences such as this are often assembled into programs to check DMMs at many calibration points; changing functions, ranges and output levels as designed by the user. The program would also include 'display' messages to complete the printout in a recognizable form for the user's convenience. Programs must also cater for FAIL and ERROR SRQs.

With a Datron Autocal DMM, other sequences can cause the DMM errors to be reduced until they are within specification, using its 'calibrate' mode.

# Using the 4700 in a System

## ADDRESSING THE 4700

### Bus Address

The instrument address is set manually using a six-way miniature switch near the interface connector on the rear panel. Five of the switches are used to set any address in the range 00 to 30, using a binary code.

e.g. Switch setting - ADD 11010 = ADDRESS 26

A5	A4	A3	A2	A1	Decimal Code
0	0	0	0	0	00
0	0	0	0	1	01
0	0	0	1	0	02
0	0	0	1	1	03
0	0	1	0	0	04
0	0	1	0	1	05
0	0	1	1	0	06
0	0	1	1	1	07
0	1	0	0	0	08
0	1	0	0	1	09
0	1	0	1	0	10
0	1	0	1	1	11
0	1	1	0	0	12
0	1	1	0	1	13
0	1	1	1	0	14
0	1	1	1	1	15
1	0	0	0	0	16
1	0	0	0	1	17
1	0	0	1	0	18
1	0	0	1	1	19
1	0	1	0	0	20
1	0	1	0	1	21
1	0	1	1	0	22
1	0	1	1	1	23
1	1	0	0	0	24
1	1	0	0	1	25
1	1	0	1	0	26 (e.g. above)
1	1	0	1	1	27
1	1	1	0	0	28
1	1	1	0	1	29
1	1	1	1	0	30

Table 5.3 Address Selection

### 'ADD'

The sixth switch is provided for possible future variants. In the 4700, the position of the ADD switch is immaterial, as the normal bus addresses can be selected at either setting.

### Addresses 0-30

With an address selected in the range 0 to 30 the instrument may be controlled manually, or remotely as part of a system on the Bus. The address selected must be the same as that used in the controller program to activate the 4700.

**N.B.** The selected address can be temporarily displayed on the front panel when in manual control, by touching **Error** and then **Guard**.

### Remote Operation

When the 4700 is operating under the direction of the controller, the legend **rem** appears on the mode display, and all front panel controls are disabled except **Power** and **Reset**.

On entering remote, any earlier (manual) selection of **Error** mode is cancelled. During remote operation, the facilities of **Error** mode are excluded, as they can easily be programmed into the controller. **Spec** mode is also cancelled, but 'Spec' information can be obtained by bus command. There is no **Spec** mode display on the front panel during remote operation.

The 4700 power-up sequence is performed as for manual operation. After power-up, and on recovery from a power failure, the 4700 generates an **SRQ** and prepares an '**RQS Status Byte**' for transmission to the controller as a response to its subsequent **serial poll**.

### Calibration Enable

A '**Calibration Enable**' command via the bus is required to set the instrument into its Remote Calibration mode (the **CALIBRATION ENABLE** keyswitch on the rear panel must already be set at **ENABLE**). Selection of any address 0-30 inhibits manual calibration from the front panel.

### Address 31 (Illegal bus address)

This address configures manual operation only, inhibiting remote facilities. Address 31 **must** be selected (with **CAL** key set to **ENABLE**), for manual calibration to be carried out.

### Temporary Transfer to Local Operation (GTL)

The 4700 can be programmed to switch into '**Local**' operation (Command **GTL**), permitting a user to take manual control from the front panel. The system controller regains '**Remote**' control by sending the

following overriding commands:

#### LAD with REN True

The controller addresses the 4705 as a listener with the **Remote Enable** management line true (Low). This returns the 4705 from local to remote control. Any commands which had been sent during the period under local control will then be executed.

#### SDC

Specific '**Device Clear**' commands are sent over the bus, returning the 4705 to a predetermined state (described later in this section).

## Programming Instructions

### Programming Strings

From the example given earlier in this section it is evident that the 4705 requires an address code followed by a series of device-dependent messages or commands to alter its configuration.

A series of these commands can be sent together as a '**program string**', each programming instruction being position-independent.

Each string will contain at least one programming instruction (detailed later in this section), but the 4705 must receive the string '**terminator**' before it can activate any instructions. The required terminator for the 4705 is the ASCII character '='.



To assist in eliminating incorrect programming instructions, the 4705 checks for errors in the string, and generates a service request (**SRQ**) if a syntax error occurs or if an option is called for but not fitted. To ensure that the programming string does not set up a prohibited state, it also checks the whole string for validity. If it finds any errors in this phase, the whole command string is ignored.

#### For Example:

With the 4705 set in 10mV Range, a string is received which contains an unacceptable command to switch Sense connection ('S' command). The user needs to set up a completely new, valid string; so the whole string is discarded.

### Device-dependent commands

To give maximum scope for system programming, the bus operation of the 4705 differs in detail from manual operation, which is organized for ease of front panel use. Some functions of the 4705 firmware are deleted for bus operation, as they are easily programmed into the system controller; and extra functions have been made available to take advantage of the controller's added computing power.

The following Alphabetic codes are used to establish the required functioning of the 4705 as a calibration source:

Full Range/Zero:	A
Safety Delay Override:	D
Output ON/OFF:	O
Function DCV, ACV, DCI, ACI, R:	F
Output Range in all Functions:	R
Output Value:	M
Frequency:	H
Sense:	S
Guard:	G
'Calibrate' trigger:	C
Calibration Mode Enable:	W

The following Alphabetic codes are used to select and configure the messages to be passed by the 4705 via the IEEE Bus:

User memory	I
Output string terminators:	K
Notation of output values:	L
Specification tolerances (relative: per unit):	P
Specification tolerances (absolute limits):	U
Recall/Verify (relative):	V
Service request origination:	Q
Diagnostic information:	X

Table 5.4 lists the range of device-dependent command codes available.

Fig. 5.3 summarizes the way that front panel functions are transferred to system operation.

CONTROL	CODE	DESCRIPTION
Full Range/Zero	A0	Zero ) But not in Autorange
	A1	+ Full Range ) i.e. not if R0 set
	A2	- Full Range )
Calibration Mode	C0	"CAL" (Calibration Trigger) <b>see Section 8</b>
	C1	"SET"
	C2	"STD"
	C3	"±0" (in DC)
	C4	"Preca" (in AC)
Safety Delay	C5	DC Coarse Gain
	D0	DC Linearity
	D1	Safety delay Active Safety delay Over-Ridden
Function	F0	V (DC Voltage)
	F1	V~ (AC Voltage)
	F2	A (DC Current)
	F3	A~ (AC Current)
	F4	R (Resistance)
Guard	G0	Local Guard
	G1	Remote Guard
Frequency	H****	Numeric value of frequency
Memory (users Aide-Memoire)	I	Store next 16 ASCII characters
Output String Terminators	K0	Cr followed by Lf with EOI
	K1	Cr followed by Lf
	K2	Cr with :EOI
	K3	Cr
	K4	Lf with EOI
	K5	Lf
	K6	EOI with last character
	K7	No terminator
Value Notation (Output to bus)	L0	Scientific with legends
	L1	Scientific with no legends
	L2	Engineering with legends
	L3	Engineering with no legends
Main Register Value	M±***	Numeric value of 'Output' display
Output	O0	Output OFF
	O1	Output ON
Specification Tolerance	P0	24 hours
	P1	90 days
	P2	1 year
Service Request	Q0	SRQ on all specified states
	Q1	SRQ on Overload and Fail only
	Q2	No SRQs
Output Range	R0	Autorange
	R1	100μ ---
	R2	1m 10Ω
	R3	10m 100Ω
	R4	100m 1kΩ
	R5	1 10kΩ
	R6	10 100kΩ
	R7	100 1MΩ
	R8	1000 10MΩ
	R9	--- 100MΩ
Sense	S0	Local Sense
	S1	Remote Sense
Specification Tolerance (Absolute Limits of Uncertainty)	U0	24 hours )
	U1	90 days ) Output low limit to bus
	U2	1 year )
	U3	24 hours )
	U4	90 days ) Output high limit to bus
Recall/Verify	U5	1 year )
	V0	'Output' Value
	V1	'Frequency Setting'
	V2	4705 Status
	V3	Software Status (Part No/Issue)
	V4	F1 )
	V5	F2 )
	V6	F3 ) Recall 'Stored' frequency value
	V7	F4 )
V8	F5 )	
Calibration	W0	Calibration Mode Disable
	W1	Calibration Mode Enable
Diagnostic (The calstore values relate to the function set at the time) Refer to Calibration and Servicing Handbook for description of correct process.	X0	Zero Cal Store
	X1	Gain Cal Store
	X2	STD Cal Gain Factor
	X3	Zero offset ) Factory
	X4	Gain offset ) corrections
	X5	Linearity (not AC) )
	X6	Reference Divider Setting
	X7	Not Used
X8	User Message Recall	

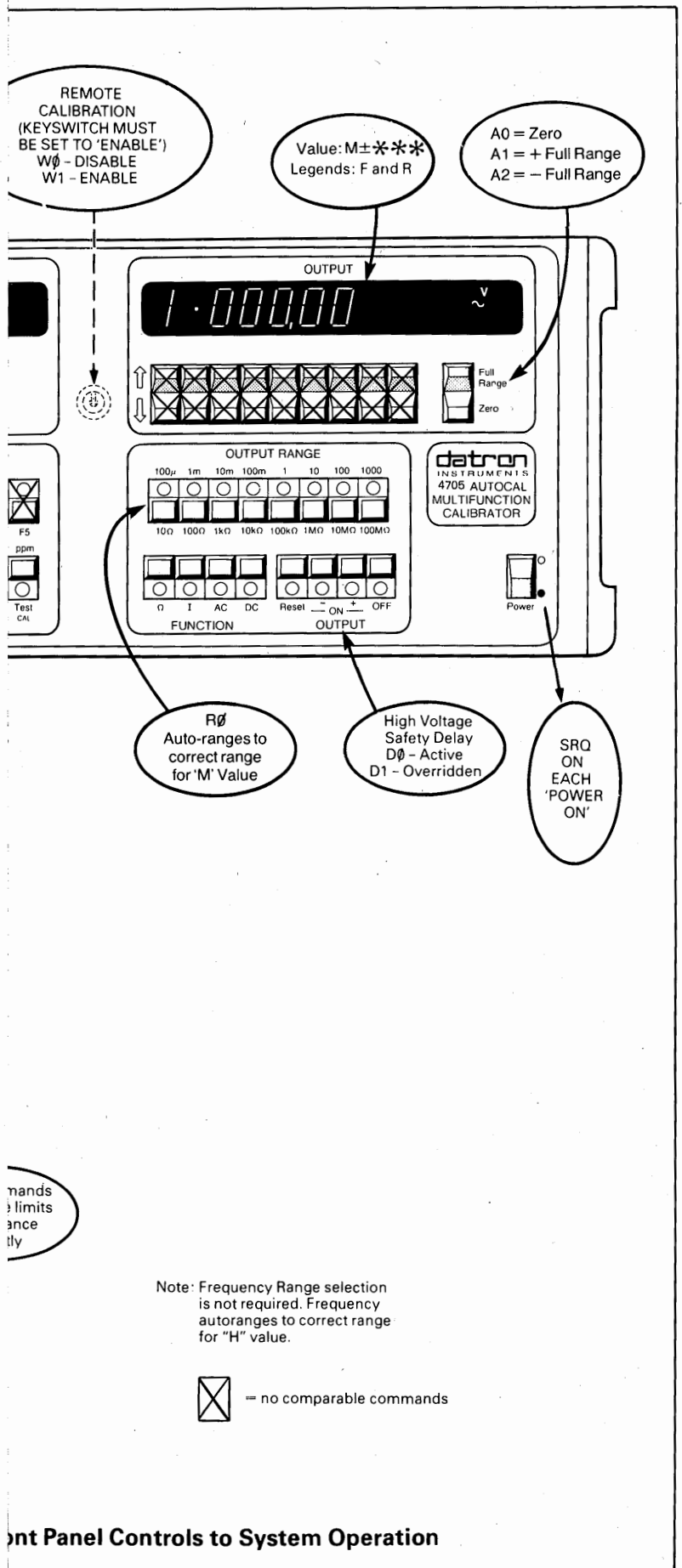

Front Panel Controls to System Operation

Table 5.4 4705 IEEE 488 Command Codes

CONTROL	CODE	DESCRIPTION
Full Range/Zero	A0	Zero ) But not in Autorange
	A1	+ Full Range ) i.e. not if R0 set
	A2	- Full Range )
Calibration Mode	C0	"CAL" (Calibration Trigger) <b>see Section 8</b>
	C1	"SET"
	C2	"STD"
	C3	"±0" (in DC)
	C4	"Preca" (in AC)
Safety Delay	C5	DC Coarse Gain
	D0	DC Linearity
	D1	Safety delay Active
Function	F0	Safety delay Over-Ridden
	F1	V (DC Voltage)
	F2	V~ (AC Voltage)
	F3	A (DC Current)
	F4	A~ (AC Current)
Guard	G0	R (Resistance)
	G1	Local Guard
Frequency	G1	Remote Guard
	H****	Numeric value of frequency
Memory (users Aide-Memoire)	I	Store next 16 ASCII characters
	Output String Terminators	K0
K1		Cr followed by LF
K2		Cr with :EOI
K3		Cr
K4		LF with EOI
K5		LF
K6		EOI with last character
K7		No terminator
Value Notation (Output to bus)	L0	Scientific with legends
	L1	Scientific with no legends
	L2	Engineering with legends
	L3	Engineering with no legends
Main Register Value	M±***	Numeric value of 'Output' display
	Output	O0
O1		Output ON
Specification Tolerance		P0
	P1	90 days
	P2	1 year
Service Request	Q0	SRQ on all specified states
	Q1	SRQ on Overload and Fail only
	Q2	No SRQs
Output Range	R0	Autorange
	R1	100μ ---
	R2	1m 10Ω
	R3	10m 100Ω
	R4	100m 1kΩ
	R5	1 10kΩ
	R6	10 100kΩ
	R7	100 1MΩ
	R8	1000 10MΩ
	R9	--- 100MΩ
Sense	S0	Local Sense
	S1	Remote Sense
Specification Tolerance (Absolute Limits of Uncertainty)	U0	24 hours )
	U1	90 days ) Output low limit to bus
	U2	1 year )
	U3	24 hours )
	U4	90 days ) Output high limit to bus
	U5	1 year )
Recall/Verify	V0	'Output' Value
	V1	'Frequency Setting'
	V2	4705 Status
	V3	Software Status (Part No/Issue)
	V4	F1 )
	V5	F2 )
	V6	F3 ) Recall 'Stored' frequency value
	V7	F4 )
V8	F5 )	
Calibration	W0	Calibration Mode Disable
	W1	Calibration Mode Enable
Diagnostic (The calstore values relate to the function set at the time) Refer to Calibration and Servicing Handbook for description of correct process.	X0	Zero Cal Store
	X1	Gain Cal Store
	X2	STD Cal Gain Factor
	X3	Zero offset ) Factory
	X4	Gain offset ) corrections
	X5	Linearity (not AC) )
	X6	Reference Divider Setting
	X7	Not Used
	X8	User Message Recall

Table 5.4 4705 IEEE 488 Command Codes

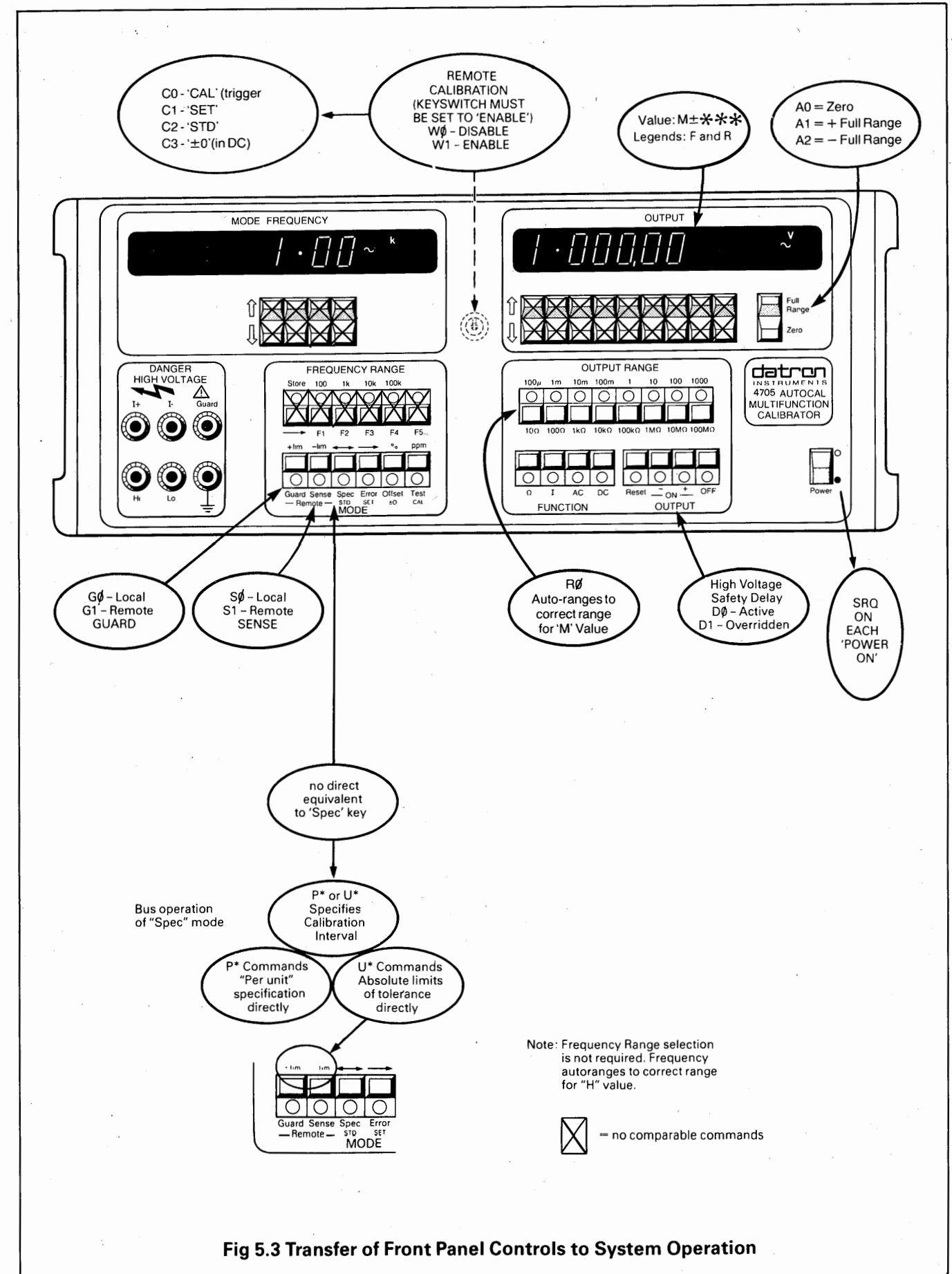
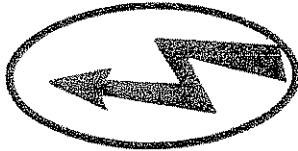

Fig 5.3 Transfer of Front Panel Controls to System Operation

# DANGER

## HIGH VOLTAGE



FRONT or REAR  
terminals carry the  
Full Output Voltage.

### THIS CAN KILL!

**READ THIS:** For manual operation, the 4700 High Voltage Interlocks ensure that users employ deliberate actions before voltages in excess of 110V DC or 75V RMS are generated at the OUTPUT terminals.

In system applications, the same interlocks require the same deliberate commands to be received from the system controller. (But see Safety Delay Override command D1 in the text).

In manual operation the user who is exposed to danger from high voltages also has direct control of the 4700 output, but it is not possible to give the same degree of built-in protection to exposed users when the instrument is under remote program control. This danger is intensified by the high speed of remote programming, so it is **ESSENTIAL** that

**WHENEVER THE 4700 IS BEING USED IN A SYSTEM TO GENERATE VOLTAGES IN EXCESS OF 75V, THERE MUST BE NO ACCESS TO THE 4700 FRONT PANEL OR REAR PANEL OUTPUT TERMINALS.**

Unless **you** are **sure** that  
it is **safe** to do so,

**DO NOT TOUCH** the  
**I+ I- Hi or Lo leads**  
and **terminals**

# DANGER

# Programming of Operational Functions

## OUTPUT ON/OFF

The analog OUTPUT is switched off by command **O0** (output disable), and switched on to the selected value by **O1**. The amplitude and frequency of the output are derived from the 'M' code and 'H' code data used to set the 'Main' (OUTPUT display), and 'Auxiliary' (MODE/FREQUENCY display) registers.

## Safety Delay

The High Voltage Safety delay (3 seconds) is normally active (**D0**). It can be overridden by the command **D1**, but the use of this command sets up potentially dangerous situations. **D0** is enforced by any Function or Range change (including Autorange changes).

## WARNING:

**DO NOT USE D1 UNLESS IT IS ESSENTIAL FOR HIGH SPEED OPERATION. TAKE SAFETY PRECAUTIONS TO PROTECT PERSONNEL IN THE VICINITY.**

## Function

**F0** (DC Voltage), **F1** (AC Voltage), **F2** (DC Current), **F3** (AC Current) and **F4** (Resistance) configure the instrument to the required function.

## Output Range

**R1** through to **R9** configure the 4700 to specific ranges as shown earlier in Table 5.4. **R0** puts the instrument in auto-range function, allowing the output value to be specified as a number without setting the actual range. Ranging down occurs at 20% of range, i.e. Full Scale value of next lower range. Ranging up occurs at Full Scale. In autorange, commands **A0**, **A1** and **A2** are invalid.

## Output Display Value (Main Register)

In remote programming, the incremental  $\Delta$  method of setting the output value is not used. Instead, Code **M±\*\*\*** is used to set the output value explicitly, either in numeric, scientific or engineering notation

(see examples below). If the resolution is too high, the value is truncated to the correct resolution and the controller is informed by SRQ and RQS Status byte (see RQS status byte formats later in this section).

## High Voltage Outputs

The change from Low to High voltage state is controlled by the same interlocks which govern the manual changeover (Refer to Section 4, page 4-7). To effect the changeover, the command string:

**'M (followed by voltage) O1 ='**

should be used if OUTPUT is already on and a range change is not involved. If a range change is programmed to set the output into high voltage state (for instance in **R0**) the 'O1' should be sent as a separate string.

If the M code alone is attempted (**M\*\*\*\*...=**) with OUTPUT already enabled (**O1**), the new value is set in the Main Register (OUTPUT display); but the output voltage will not ramp to high voltage state until the enabling string 'O1 =' is received.

If the attempt had been made with OUTPUT disabled (**O0**), the **O1** would be required in any case.

It should also be remembered that the output circuitry needs time to settle to its final value, especially if a range-change is incurred. Delays should be included in the controller program to allow for this.

During these processes, the front panel warnings of flashing LEDs and pulsing tones operate as for manual operation. Nevertheless, access to the front panel should be restricted because the high speed of programming in the IEEE interface adds to the safety hazard.

## Examples of valid M codes:

Required Output Value	Function	Range	M Code	Output Display
-153V	F0	R7	M-153	-153.000,0V
+1.621257V	F0	R5	M+1.6212574	+1.621,2574V
1.621257V RMS	F1	R5	M1621257E-6	1.621,257V~
1.621257V RMS	F1	R0	M1621.257E-03	1.621,257V~ (Autorange to R5 = 1V)
0.002563A RMS	F3	R0	M.002563	2.56300mA~ (Autorange to R3 = 10mA)



### Output Resolution

The output resolution conforms to the following number of digits:

Range		100 $\mu$	1m	10m	100m	1	10	100	1000
Range Code		10	100	1k	10k	100k	1m	10m	100m
		R1	R2	R3	R4	R5	R6	R7	R8
Functions:									
DC Voltage	F0	4½	5½	6½	7½	7½	7½	7½	7½
AC Voltage	F1	—	4½	5½	6½	6½	6½	6½	6½
DC Current	F2	6½	6½	6½	6½	6½	—	—	—
AC Current	F3	6½	6½	6½	6½	6½	—	—	—
Resistance and Local Sense	F4 } S0 }	4½	5½	6½	7½	7½	7½	7½	7½
Resistance and Remote Sense	F4 } S1 }	7½	7½	7½	7½	7½	7½	7½	7½

### Frequency Display Value (Auxiliary Register)

In remote programming, the incremental ( $\Delta$ ) method of setting the frequency is not used. Instead, each auxiliary register value is input explicitly by Code H\*\*\*\* in numeric, scientific or engineering notation.

The manual frequency 'Store' memories cannot be set via the bus, although their contents can be read using 'V' codes.

### Frequency Resolution

Frequency is resolved to three significant digits (1% to 100ppm accuracy). On the display this occupies four digit spaces, to accommodate the decimal point. If the significance is greater than three digits, the value is truncated and the controller is informed by SRQ Status byte (see SRQ status byte formats later in this section).

### Frequency and Voltage Constraints

On 100V and 1000V output ranges, the 4700 will refuse any command for an output which exceeds the limits defined on page 3-6. The controller is informed by 'Error 7' SRQ status byte (see SRQ status byte formats later in this section).

### Guard and Sense

These are configured into Local or Remote by G or S codes respectively:

- G0 — Local Guard
- G1 — Remote Guard
- S0 — Local Sense (forced when F2 or F3 has

been commanded and when F0, R1, R2, R3 and R4 or F1, R2, R3 and R4 have been commanded). Programs for 2-wire resistance in F4.

- S1 — Remote Sense (available only when F0 or F1 have been selected together with R5, R6, R7 and R8 or when F4 has been selected in all ranges). Programs for 4-wire resistance in F4.

These bus commands are subject to the constraints of the 4700 firmware. The instrument will reject and ignore invalid commands, such as Remote Sense when in 100mV range.

### Calibration Enable and Calibrate (W and C codes)

These are available for automatic calibration of the 4700, under remote control via the IEEE bus. Refer to the Calibration and Servicing Handbook.

- W0 — Calibration disable
  - W1 — Calibration enable (only if CALIBRATION ENABLE keyswitch set to ENABLE).
  - C0 — Calibration Trigger — equivalent to CAL key.
  - C1 — As SET key.
  - C2 — As STD key.
  - C3 — As  $\pm 0$  key (in DC)
- } Refer to Section 8.

# Programming of Bus Transmissions

## Output String Formation

The 4700 can be commanded to output 'internal' information to the system via the IEEE 488 bus, by sending one of the specified 'recall' messages.

Only one recall command should be included in a terminated string.

As well as the information it contains, the string needs to be formatted correctly for acceptance by the system. Many variations of format are available; these can be programmed for the type of system in use.

The length and construction of the string both depend upon the type of information to be transmitted, and thus upon the codes used to program the 4700. The purpose of this explanation is to describe the effects of these codes on the output string format.

Figure 5.4 illustrates the construction of a typical string, such as the 4700 output value. Notice that numerical data is reduced to a standard form, and scaled by means of an exponent in base 10. All device-dependent messages use the ASCII code.

**Figure 5.4 Breakdown of a Typical Output String**  
(This is a general example — two specific 4700 examples appear on page 5-12)

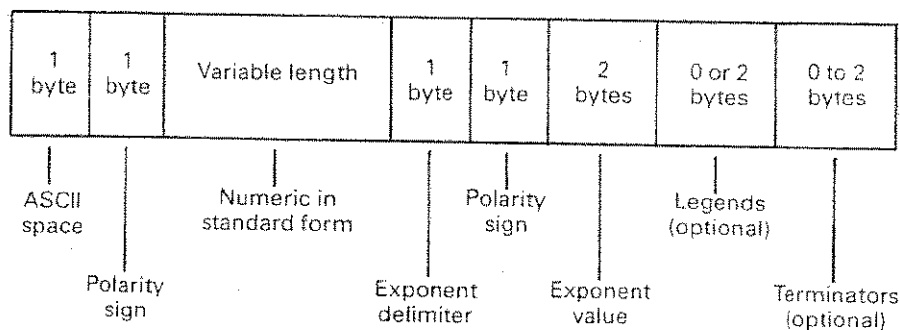

### ASCII 'Space'

A format character to denote the beginning of an output string — not present for recall command **X8**.

### Polarity sign

Replaced by an ASCII space in AC Functions. For DC functions, the appropriate polarity sign is presented.

### Numeric sub-string

Length depends on the resolution of the information to be transmitted, and form depends on the notation programmed by 'L' code.

### Exponent delimiter 'E'

Signifies that the numeric has finished and the next three bytes form the exponent.

### Exponent value

The first of the three bytes is always '+' or '-'. Because the value is never greater than 9, the second byte is always 0, and the third is a single decimal digit.

### Legends

Inclusion is optional, but if they are programmed in, two bytes are always present. The characters are appropriate to the programmed state of the 4700.

### Terminators

Two terminating characters are available, as programmed by 'K' code. The EOI bus management line can optionally be programmed for simultaneous transmission with the last byte of the string.

## Format Codes

The following pages list and describe the programming codes which determine the formation of the output string. The codes on page 5-11 select specific types of ASCII strings for retrieval.

### Recall/Verify (code V).

By sending a V code the controller interrogates the 4700 to obtain information about its present status. Unless otherwise stated, the output strings are formatted as programmed by K and L codes. The V codes are as follows:

V0 — The present Output value.

V1 — The present Frequency setting

V2 — The present functional status.

The response to V2 is a standard ASCII string: (space R\*F\*O\*G\*S\*W\*Q\*D\*L\*K\* terminator). The functions are represented by the same numerics as for programming. In addition, the Output Range is identified by a lower case 'r' if the 4700 is programmed in autorange.

V3 — Software status.

The software status is the part number and issue number of the internal program. This is formatted as follows, in response to command code V3:

(space 890077 — numeric terminator)

▲	▲
Part No.	Issue No.

(This status report is also available manually by pressing Error key then Lim—. The firmware issue-number is presented on the MODE display).

V4 to V8 — 'Stored' Frequencies.

Codes V4 to V8 recall each of the five frequencies held in volatile memory locations F1 to F5. These can only be set or selected manually. (Refer to page 3-7.)

The range of legends transmitted by the 4700 is listed under 'String Formatting Commands (K and L Codes)'.

### I-code (Aide-Memoire)

This allows the user to identify a specific calibrator with a designator up to 16 characters in length, stored in non-volatile memory. The 4700 must first be placed in the CAL mode by turning the CAL key to ENABLE and sending the W1 command. Sending the I command will store the subsequent 16 character string in memory. This string can be recalled using the X8 command.

N.B. The I-command and the W1 command must not be sent in the same string.

### Specification Tolerance (Per unit — P codes).

The P commands give access to Spec mode over the

bus, also setting the calibration interval:

P0 — 24 hour; P1 — 90 day; P2 — 1 year.

On being commanded by P code, the 4700 calculates the Output Uncertainty of its current state (as a 'per unit' fraction of the output value) and generates an output string formatted by K and L codes. Legends are transmitted as pu (per unit).

### Absolute Limits of Tolerance

In this case, the U commands cause the 4700 to calculate the high or low limit of uncertainty of its output value against the nominated calibration interval.

U0 — Low limit 24 hour

U1 — Low limit 90 day

U2 — Low limit 1 year

U3 — High limit 24 hour

U4 — High limit 90 day

U5 — High limit 1 year

On being commanded, the calculated value is output by the 4700 in an output string formatted by K and L codes.

### Diagnostic Information

The X commands recall the contents of certain non-volatile calibration memory locations. The values recalled are calibration constants stored at the most recent Autocalibration. They are used in the computations which establish the 4700 output level, as corrections for long-term drift in the analog circuitry.

X0 — Zero Cal. Store

X1 — Gain Cal. Store in DC, LF gain + HF calibration in AC

X2 — 'STD' calibration gain factor

X3 — Zero offset

X4 — Gain error

X5 — Linearity (not AC)

X6 — Reference Divider setting

X7 — Not used in 4700

X8 — Recall message which was memorized earlier by the operator using Code I.

### Activating the Recall Transmission

The 4700 assembles the appropriate output string in its output registers in response to the V, P, U or X command. It can subsequently be released onto the bus by addressing the 4700 as a talker.

### String Formatting Commands (K and L Codes).

The output string can be formatted and terminated to adapt to user's requirements. Scientific or Engineering notation can be programmed, with or

without descriptive legends. Two examples are given below.

Codes L0 to L3 configure the output string notation:

- L0 — Scientific notation with legends
- L1 — Scientific notation, no legends
- L2 — Engineering notation with legends
- L3 — Engineering notation, no legends

Two sorts of terminator are available:

- a. One or two bytes can be added to the end of the string. These contain either Carriage Return (Cr) or Line Feed (Lf); or both in the order: Cr followed by Lf.
- b. The EOI bus management line can be programmed to set true simultaneously with the last byte of the string. EOI can be used even if both Cr and Lf are suppressed.

The 4700 can also be programmed to transmit strings without terminators. To accommodate these variations, the system programmer uses the K codes:

- K0 — No suppression (Cr, Lf and EOI all present as terminators)
- K1 — Suppress EOI (Terminator Cr followed by Lf)
- K2 — Suppress Lf (Terminator Cr with EOI)
- K3 — Suppress Lf and EOI (Terminator Cr)
- K4 — Suppress Cr (Terminator Lf with EOI)
- K5 — Suppress Cr and EOI (Terminator Lf)
- K6 — Suppress Cr and Lf (Terminator EOI with last character)
- K7 — Suppress Cr, Lf and EOI (No terminators).

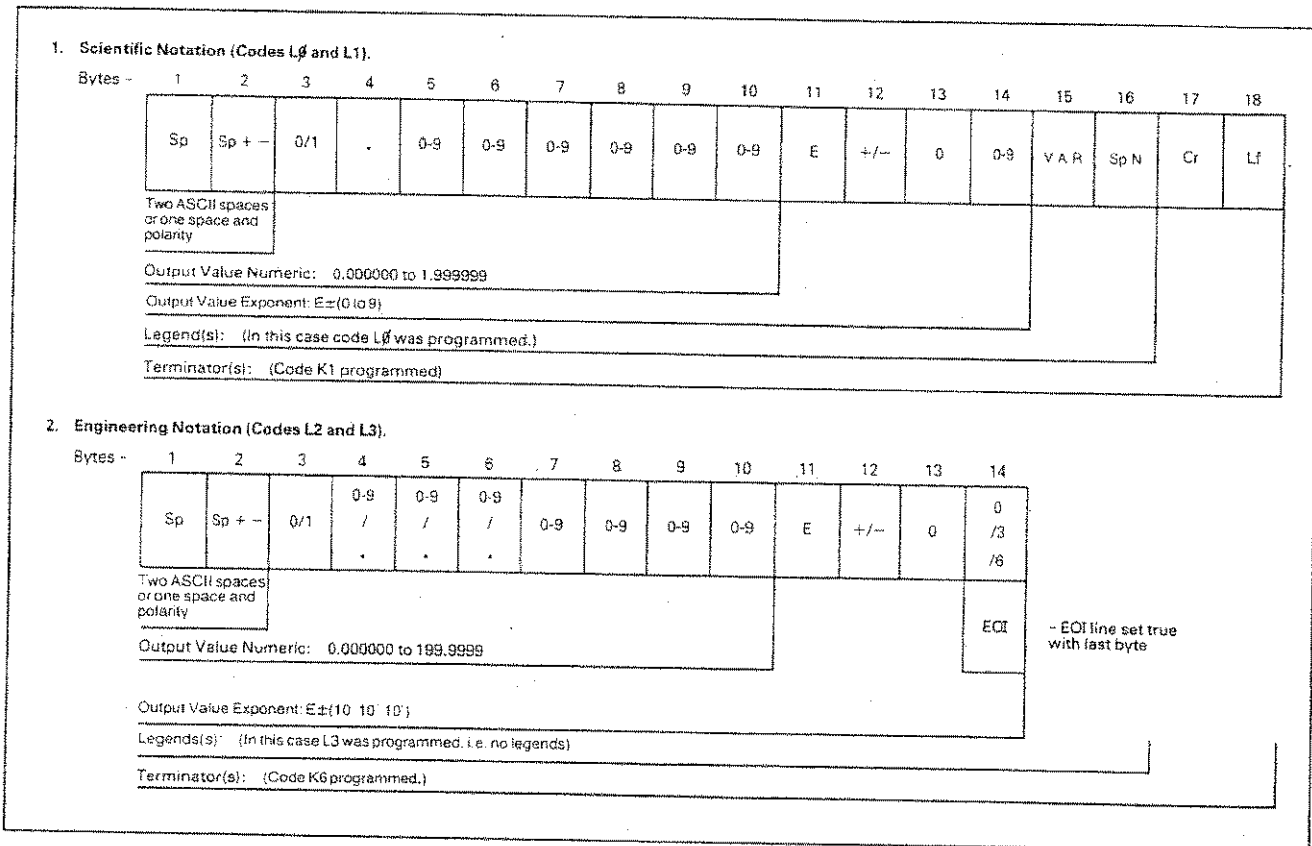

**Descriptive Legends.**

The following Legends will be fitted into the string after the exponent, if programmed by codes L0 or L2:

Recall	Function	Legend	Meaning	Recall	Legend	Meaning
V0, )	U0-U5	F0	V	P0-P2	pu	per unit
V0, )	U0-U5	F1	V~	Frequency	Hz	frequency
V0, )	U0-U5	F2	A			
V0, )	U0-U5	F3	A~			
V0, )	U0-U5	F4	R			

### Service Request

The 4705 can asynchronously request service from the controller by putting the **SRQ** line true (low).

SRQ is always generated by the action of switching the 4705 power ON, as the power-up default mode is **Q0**.

A user can program the 4705 to generate SRQs (or not) using command code Q:

- Code **Q0** — SRQ on any of the states in Table 5.5
- Q1** — SRQ on overload and any FAIL state in Table 5.5
- Q2** — No SRQs generated

### Serial Poll and RQS Status Byte

If programmed for SRQ response, the bus controller will pause in its operation to attend to the service request. It first conducts a serial or parallel poll to determine which device initiated the SRQ. The 4705 does not react to parallel poll, but only to serial poll, during which each device is addressed in turn. The instrument responds to its serial poll address by releasing a prepared 'RQS Status Byte' on to the bus. The RQS Request Bit (bit B7 of its status byte) is set true (Low) only if the 4705 has generated the SRQ. This validates the remainder of the byte, which describes the causal condition by the state codes listed in Table 5.5.

### RQS Status Byte Composition

- bit **b8**: Indicates a syntax error when true.
- bit **b7**: The RQS request bit, when true, confirms that the 4705 was the SRQ originator. The RQS status byte is not valid unless bit b7 is true.
- bit **b6 true**: Each combination of bits b5-b1 represents a single state as listed in Table 5.5
- bit **b6 false**: Bits b5-b1 each represent separate functional states within the 4705, and the RQS byte represents several states as listed in Table 5.5

### Example with bit b6 false:

RQS status byte 01000001 represents:

- 0 — Syntax error.
- 1 — This instrument originated the SRQ.
- 0 — The following bits each represent separate states.
- 0 — This bit is not used in the 4705.
- 0 — No High Voltage warning.
- 0 — Auxiliary register not at limit.
- 0 — Main register not at limit.
- 1 — Output is ON.

The RQS status byte should not be confused with other status messages (e.g. 'calibrator' or 'software' status, described earlier under 'Recall/Verify') which are called up by the system controller's program.

### DIO Line Transmissions

Providing **Q0** or **Q1** has been selected; when the 4705 has a message to transmit over the DIO lines, it sets the SRQ line true and prepares the 'Recall' RQS status byte (**x1100000**) ready for the subsequent serial poll. On receiving the status byte, the controller can address any device required to receive the data as a listener, and address the 4705 as a talker. Then the message is sent via DIO lines to the programmed listener(s).

### Fail Messages

The 4705 needs to react quickly to internally-generated **FAIL** messages and is programmed to take rapid protective action. A fault condition may generate a train of such internal messages, which occur too quickly for some controllers to detect.

Such a train may be terminated by a **FAIL 5** message, which is detected by the controller. Thus the receipt of **FAIL 5** by a controller should be taken as a final default condition, and not as indicating the origin of the fault. The **FAIL 5** message can be cleared, if the 4705 has recovered, by pressing the **Reset** key on the instrument front panel. As **FAIL 5** is related to safety, it cannot be reset by remote control.

Table 5.5 lists the possible RQS status bytes which may be transmitted by the 4705. The information in the byte is valid only if bit 7 (request bit) is true.

Legend: 1 = True, 0 = False, X = 1 either 1 or 0								
bits								
b8	b7	b6	b5	b4	b3	b2	b1	
1	1	X	X	X	X	X	X	Syntax error
X	1	X	X	X	X	X	X	RQS Request-for-service bit
Combination Status Messages								
X	1	0	X	X	X	X	1	Output ON
X	1	0	X	X	X	1	X	Main Register limit reached
X	1	0	X	X	1	X	X	Auxiliary Register limit reached
X	1	0	X	1	X	X	X	High Voltage Warning.
Individual Status Messages								
X	1	1	0	0	0	0	0	Recall message available
X	1	1	0	0	0	0	1	Error 1 Specification not displayable
X	1	1	0	0	0	1	0	Error 2 CAL mode: Output not ON
X	1	1	0	0	0	1	1	Error 3 CAL mode: Incorrect Range/Function
X	1	1	0	0	1	0	0	Error 4 CAL mode: Insufficient store span
X	1	1	0	0	1	0	1	Error 5 Error or Offset mode: Overscale output requested
X	1	1	0	0	1	1	0	Error 6 CAL mode: Resistance selected exceeds val. value
X	1	1	0	0	1	1	1	Error 7 AC Functions: Output has been limited by internal frequency constraints
X	1	1	0	1	0	0	0	Error 8 General selection error
X	1	1	1	0	0	0	0	Fail 0 Fault condition rectified
X	1	1	1	0	0	0	1	Fail 1 Over-temperature
X	1	1	1	0	0	1	0	Fail 2 Over-voltage
X	1	1	1	0	0	1	1	Fail 3 Control data corrupted
X	1	1	1	0	1	0	0	Fail 4 Precision divider fault
X	1	1	1	0	1	0	1	Fail 5 Safety alarm
X	1	1	1	0	1	1	0	Fail 6 Cal. store sum check non-parity
X	1	1	1	0	1	1	1	Fail 7 400V power supply fault (automatically resets if temporary)
X	1	1	1	1	0	0	0	Fail 8 3V power supply fault
X	1	1	1	1	0	0	1	Fail 9 15V In-guard power supply fault
X	1	1	1	1	0	1	1	Reset. Instrument reset to power-up state
X	1	1	1	1	1	0	0	Error EF External frequency not present
X	1	1	1	1	1	1	0	Overload - Current or Voltage limit
X	1	1	1	1	1	1	1	Power-on

**Table 5.5 Status Byte Coding**

- Notes:** (1) Power-up condition:  
 DØ FØ GØ KØ LØ MØ OØ QØ RØ (1V) SØ WØ  
 Device clear condition as power-up but K = and L = continue unchanged
- (2) Program string terminator: '=' activates preceding string.

## Activation of Commands

### Use of Terminator

The 4705 activates single or multiple commands, only on receipt of the recognized terminator. This is the ASCII character '='.

Commands or command strings may be received while the instrument is in Local control, but will not be activated even if a terminator is present, until the instrument is set to Remote control. The two 'Clear' messages (**DCL** and **SDC**) will be activated even when in Local control.

## Multiple Commands

### Activation sequence

The input buffer has a capacity of 128 characters. Commands in a multiple string may be entered in any order, provided correct character syntax is observed. They are extracted from the buffer in received sequence and stored by alpha character into command stores. Any existing commands in the store are over-written and lost.

When a string terminator is received, the commands in the store are validated. Validation ensures that the proposed instrument state (consisting of those changes programmed and those current states not reprogrammed) is valid. Any error results in the string being ignored and a syntax error generated.

New commands are executed in this sequence:

- K Output terminator format
- L Output notation
- Q SRQ Mode
- W Remote Calibration Enable
- I User Message Input
- Ø OUTPUT OFF
- G Guard
- D Safety Delay override
- F Function
- R Range
- M Main Register Value (Output)
- A Full Range/Zero
- S Sense
- H Auxiliary Register Value (Frequency)
- O1 OUTPUT ON
- C Calibrate Mode
- P Specification tolerance
- U Specification limits
- V Recall/Verify
- X Diagnostic information

A programmer may elect to change the sequence by inserting terminators between commands, but the basic constraints of the 4705 will still be imposed. For example, if the function is changed as a single command (e.g. **F3=**) the main program firmware will set **Output OFF** as a result, and it must then be re-programmed ON by the user.

### Succession of Multiple Commands

If the input buffer is not full, new commands are accepted to await their turn for processing, and are extracted string by string. The input system design makes it extremely unlikely that the buffer will overflow, unless the 4705 is in Local Control and the command input is excessive. If this does cause the buffer to fill up, the 4705 places a hold on the IEEE bus handshake sequence. The command **IFC** can be used to release the hold, followed by **DCL** to clear the 4705 input buffer; but as a general principle, this situation should be avoided by suitable reprogramming.

### Input Errors

Some unwanted commands are ignored. Others enter the input buffer and are rejected later.

### 'Read' commands

Before addressing the 4705 as a talker, it is essential that it has been programmed by a **P**, **U**, **V** or **X** command. Otherwise it will have no data to transmit.

### Universal commands

- LLO** (Local Lockout) – ignored, no capability.
- PPU** (Parallel Poll Unconfigured) – ignored, no capability for parallel poll.
- SPE** (Serial Poll Enable) – sets the 4705 to serial poll state, which when addressed responds with the **RQS** status byte. This byte contains the condition of the request-service bit (bit 7). If the 4705 is requesting service; bit 7 will be true, the other bits describing the service required.
- SPD** (Serial Poll Disable) – returns the instrument to serial poll idle state.

### Addressed commands

- PPC** (Parallel Poll Configure) – ignored, no capability.
- GET** (Group Execute Trigger) – ignored, no capability.
- TCT** (Take Control) – ignored, no capability.
- GTL** (Go To Local) – instrument returns to Manual Control. The controller regains remote control by addressing the 4705 as a listener with **REN** line true.

### Clear Commands (DCL and SDC)

When the 4700 receives either of the two 'Clear' messages, (DCL is universal and SDC is addressed to a selected device) it will default to the predetermined state defined below. During the time taken to default, the IEEE interface handshake is held. These commands are effective even in 'Local' control.

A?	Not Active (see M code)
F0	DC Volts
R0	Autorange 1V default
M0	Where value is zero
H(value)	Where value is 1kHz
G0	Local guard
S0	Local sense
O0	OUTPUT OFF state
Q0	SRQ on all specified states
D0	Safety delay active
W0	Calibration disabled
C?	Not active - disabled by W0
P?	Not active
U?	Not active
V?	Not active
X?	Not active
K*	Unchanged
L*	Unchanged

The frequency values held in 'Store' volatile memory locations F1-F5 are reset to the default state described on page 3-7.

## Operational Sequence Guidelines

Most interface communication tasks require sequences of coded messages to be sent over the interface. Many controllers assign a single programming instruction to a complete sequence, so it is advisable to study the available controller capabilities carefully before attempting to program a system. Because the IEEE Std 488 (1978) allows a certain latitude in bus protocol, considerable differences may be found between programming instructions and operating sequences from one make of controller to another. Consequently, the following sequences are recommendations only.

### Data Transfer

UNL	Inhibits all current listeners
LAD <sub>1</sub>	Each address sent enables a specific device to receive future data bytes.
LAD <sub>n</sub>	More than one address may be sent if multiple listeners desired.
TAD	The address sent enables a specific device to send data. The 4700 must be already programmed to prepare data.
DAB <sub>1</sub>	Data bytes sent by currently-enabled talkers to all currently-enabled listeners.
DAB <sub>n</sub>	
UNT	Disables the talker on receipt of the last character.

UNL = unlisten
LAD = listen address of specific device
TAD = talk address of specific device
DAB = data bytes
UNT = untalk

### Serial Poll

UNL	Inhibits all current listeners
SPE	Puts interface into serial poll mode during which all devices send status instead of data when addressed.
TAD <sub>n</sub>	Enables a specific device to send status. Within this loop, device should be sequentially enabled.
SBN or SBA	Status byte sent by enabled device: If SBN, loop should be repeated. If SBA sent, the enabled device is identified as having sent SRQ and will automatically remove it.
SPD	Disables serial poll mode.
UNT	Disable last talker.

SPE = Serial poll enable
SPD = Serial poll disable
SBN = Status byte negative where bit 7 = 0
SBA = Status byte affirmative where bit 7 = 1

### Untalk

It is highly desirable that a sequence which causes a device to be addressed as a talker should be terminated by an 'untalk' command.





# DANGER HIGH VOLTAGE



**THIS INSTRUMENT IS CAPABLE  
OF DELIVERING  
A LETHAL ELECTRIC SHOCK!**



FRONT or REAR  
terminals carry the  
Full Output Voltage.

**THIS CAN KILL!**



Guard terminal is  
sensitive to over-  
voltage

**It can damage  
your instrument!**

Unless **you** are **sure** that  
it is **safe** to do so,  
**DO NOT TOUCH** the  
**I+ I- Hi or Lo leads**  
and **terminals**

# DANGER

# SECTION 6 SPECIFICATIONS

## General

### POWER SUPPLY

Voltage	: 100/120/220/240V±10%
Line Frequency	: 48Hz to 62Hz
Consumption	: 370 VA normal 660 VA full power
Fuses 220/240V	: 3.15A
100/120V	: 6.25A

### MECHANICAL

Dimensions	: Height 178mm (7") Width 455mm (17.9") Depth 564mm (22.2")
Weight	: 35kg (77lb)

<b>SAFETY</b>	: The 4700 has been designed to meet BSI 4743, IEC 348 and UL 1244 specifications
---------------	---

### PEAK TERMINAL VOLTAGES

Guard to Ground	: 920V
Lo to Guard	: 920V
Lo to Ground	: 920V
Hi to Guard	: 1556V
Hi to Ground	: 1556V
Rear Panel Digital Inputs-	
to Hi	1556V
to Lo	920V
to Guard	: 920V
to Ground	: 0V to +5V

### N.B.

Digital Common is internally connected to Ground

### ENVIRONMENTAL CONDITIONS

Operating temperature	: 0°C to +50°C
<b>CAUTION.</b> Above 30°C on 1kV Range: maximum output power is derated	
Storage Temperature	: -40°C to +70°C
Maximum Relative Humidity	: 75% at 40°C Non-Condensing
Warm-up Time	: One hour to meet all specifications

### OPERATING INDICATIONS

Indication	: Symbols lit on displays and illuminated keys
------------	--

### Scale Lengths

Output Display	: 7½ Digits maximum
Frequency Display	: 3 Digits plus store location
Mode Display	: 7½ Digits maximum

TAO  
LAB  
USE ONLY

# DC VOLTAGE (Standard to 200V, Option 10 to 1100V)

## Accuracy

46.4°F - 55.4°F  
91.4°F - 100.4°F

Range	Stability 24 hour ± (ppm OUTPUT + ppmFS) (1)(2)	Accuracy Relative to Calibration Standards ± (ppm OUTPUT + ppmFS) (2)			Calibration Uncertainty (ppm) (3)	Temperature Coefficient (±ppm OUTPUT/°C) 8°C - 13°C 33°C - 38°C	Output Resistance	Output Compliance
		24 hour 23°C ± 1°C	90 days 23°C ± 1°C	1 year 23°C ± 10°C				
100.00μV to 100.00000mV	1.2+0.6μV	3+0.8μV	6+0.8μV	15+1.0μV	10+1μV	2.0	100Ω	-
1.0000000V	1.0+0.5	2+0.8	6+0.8	15+1.0	7	1.5	<0.1mΩ	25mA
10.000000V	0.6+0.1	1+0.5	4+0.5	15+1.0	5	1.0	<0.1mΩ	25mA
100.00000V	1.0+0.3	2+1.0	6+1.0	15+1.0	9	1.5	<1mΩ	25mA
1000.0000V(4)	1.0+0.2	3+0.5	6+0.5	15+1.0	12	2.0	<10mΩ	25mA

## Noise (5)

Bandwidth Range	2.5kHz (RMS)	Average Over 1 Line Period (pk-to-pk)	Average Over 10 Line Periods (pk-to-pk)	DC - 2Hz (Typical Null Detector) (pk-to-pk)
100μV - 100mV	4μV	0.2μV	0.5μV	0.1μV
1V	4μV	2μV	0.5μV	0.5μV
10V	10μV	5μV	2μV	2μV
100V	120μV	50μV	25μV	25μV
1000V	2.5mV	600μV	200μV	150μV

## Notes:

- (1) For same conditions between 18°C and 28°C
- (2) FS=2xRange
- (3) Factory calibration uncertainty using automated calibration equipment. Datron can provide better traceability. Contact factory for details.
- (4) Requires Option 10.
- (5) For 10kHz-wide band, multiply 2.5kHz figures by 2. For RMS, divide pk-to-pk figures by 6.

## Other Specifications

- Output** True bipolar output capable of delivering 1100V with respect to Output Lo.
- Overrange** 100% on 100μV to 100V ranges, 10% on 1000V range (1100V).
- Voltage Sensing** Selectable remote or local voltage sensing on 1V to 1000V ranges.
- Guarding** Selectable remote or local guard connection. Max Guard to Ground voltage of 650V rms (2.5kV flash test).
- Common Mode Rejection** 140dB at DC to 400Hz.
- Settling Time** To 1ppm of step size < 5s.  
To 10ppm of step size < 1s.  
To 100ppm of step size < 100ms.



# DANGER HIGH VOLTAGE



**THIS INSTRUMENT IS CAPABLE  
OF DELIVERING  
A LETHAL ELECTRIC SHOCK!**



FRONT or REAR  
terminals carry the  
Full Output Voltage.

**THIS CAN KILL!**



Guard terminal is  
sensitive to over-  
voltage

**It can damage  
your instrument!**

Unless **you** are **sure** that  
it is **safe** to do so,  
**DO NOT TOUCH** the  
**I+ I- Hi or Lo leads**  
and **terminals**

# DANGER

# AC VOLTAGE (Basic to 200V, Option 10 to 1100V)

## Accuracy

Range	Frequency (Hz)	Stability 24 hour ±(ppm OUTPUT +ppm FS) (1) (2)	Accuracy Relative to Calibration Standards ± (ppm OUTPUT + ppm FS) (2)		
			24 hour 23°C ± 1°C	90 days 23°C ± 1°C	1 year 23°C ± 10°C
1.0000mV to 100.0000mV	10-31 32-33k 30k-100k 100k-330k 300k-1M	120+10+10μV 60+10+10μV 60+10+10μV 160+20+10μV 260+20+10μV	200+60+10μV 160+40+10μV 600+60+10μV 0.2%+0.02%+20μV 0.6%+0.2%+30μV	250+60+10μV 200+40+10μV 600+60+10μV 0.2%+0.02%+20μV 0.6%+0.2%+30μV	340+60+10μV 240+60+10μV 700+60+10μV 0.2%+0.02%+20μV 0.6%+0.2%+30μV
1.000000V and 10.00000V	10-31 32-33k 30k-100k 100k-330k 300k-1M	80+20 40+10 40+10 100+20 240+20	180+40 100+20 180+30 500+200 0.3%+0.1%	200+40 120+20 200+30 600+200 0.4%+0.1%	280+60 180+40 300+40 1000+200 0.6%+0.1%
100.0000V	10-31 32-33k 30k-100k	80+20 40+10 40+10	180+40 100+20 220+40	200+40 120+20 250+40	280+60 180+40 320+40
1000.000V (6)	45-330 300-10k 10k-33k	100+20 60+20 100+30	180+50 120+50 220+50	200+50 150+50 250+50	360+50 280+50 360+50

### Notes:

- (1) For same conditions between 18°C and 28°C.
- (2) FS=2x Range.
- (3) Factory calibration uncertainty using automated calibration equipment. Datron can provide better traceability. Contact factory for details.
- (4) Estimated, not fully traceable.
- (5) Predominantly second harmonic (negligible error on mean sensing instruments).
- (6) Requires Option 10.
- (7) For Frequency Range or Output Range changes, Function changes, OFF/ON changes, and Frequency changes between 31 and 32Hz: the Settling Times are doubled.
  - In remote operation via the IEEE 488 Interface, hardware switching occurs under the control of 'H' (Frequency) codes. Any transfer (up or down) between the undermentioned frequencies must be regarded as a frequency range change. Settling Time should be allowed as for 'Other Specifications.'

31-32Hz	33.0-33.1kHz
300-301Hz	330-331kHz
3.00-3.01kHz	

- For settling to 10ppm of Step Size, multiply all times by 1.5.

Calibration Uncertainty (ppm) (3)	Temperature Coefficient ( $\pm$ ppm OUTPUT/ $^{\circ}$ C) 8 $^{\circ}$ C - 13 $^{\circ}$ C 33 $^{\circ}$ C - 38 $^{\circ}$ C	Total Harmonic Distortion (%) (5)	Output Impedance at Zero to Full Load Regulation	Output Compliance
110+12 $\mu$ V 250+10 $\mu$ V 560+11 $\mu$ V 800+12 $\mu$ V (4) 1300+12 $\mu$ V (4)	10 10 10 40 100	0.1 0.04 0.1 0.3 1.0	30 $\Omega$ at all frequencies	—
160 130 170 450 1150	6 6 6 20 100	0.1 0.04 0.1 0.3 1.0	Typically 0.001% FS to 33kHz increasing to 0.3% FS at 1MHz (2)	1V Range: 25mA 10V Range: 60mA
160 130 200 (4)	6 6 10	0.1 0.04 0.2	Typically 0.002% FS to 33kHz increasing to 0.02% FS at 100kHz (2)	120mA
190 170 250	10 10 10	0.2 0.1 0.1	Typically 0.002% FS to 33kHz (2)	<3.3kHz, 15mA >3.3kHz, 65mA

### Other Specifications

Scale Length	9% to 200% of Range, 1mV to 100V ranges. 9% to 110% of range, 1000V range (1100V).
Voltage Sensing	Selectable remote or local voltage sensing on 1V to 1000V ranges.
Guarding	Selectable remote or local guard connection. Maximum Guard to Ground voltage 650V RMS (2.5kV flash test).
Common Mode Rejection	140dB at DC to 400Hz.
Settling Time (7)	To 100ppm of step size (double for range changes); 10 - 32Hz < 10s. 32 - 330Hz < 3s. > 330Hz < 1s.
Frequency Accuracy	< 100ppm, typically < 10ppm.
Maximum Load Capacitance	1V to 100V ranges: 1000pF. 1000V range: 300pF.

# VOLTAGE/FREQUENCY CONSTRAINTS

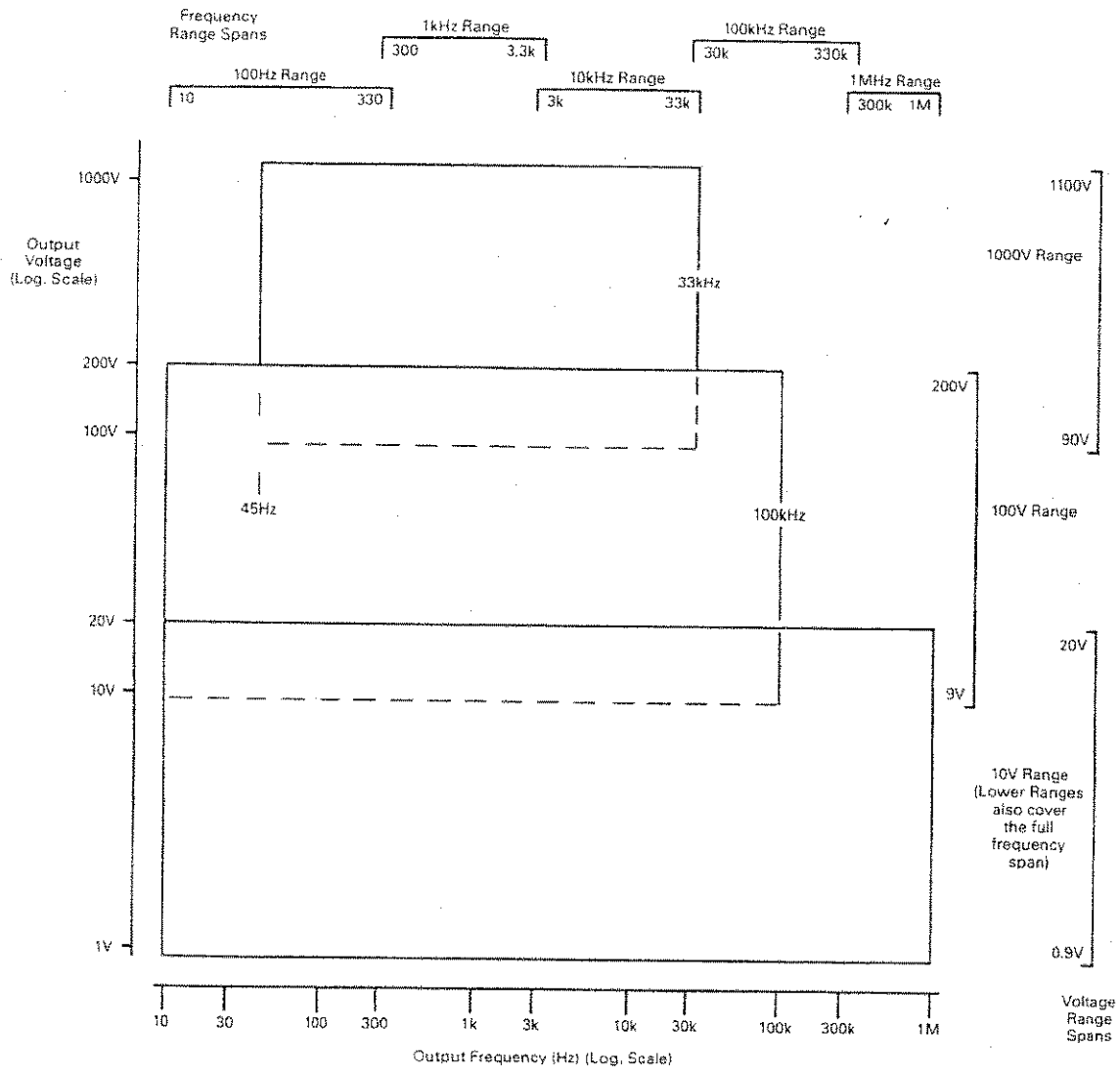

# CAPACITIVE LOADING CONSTRAINTS

Volt-Hertz Power Limit versus Capacitance Load (1 kV Range)

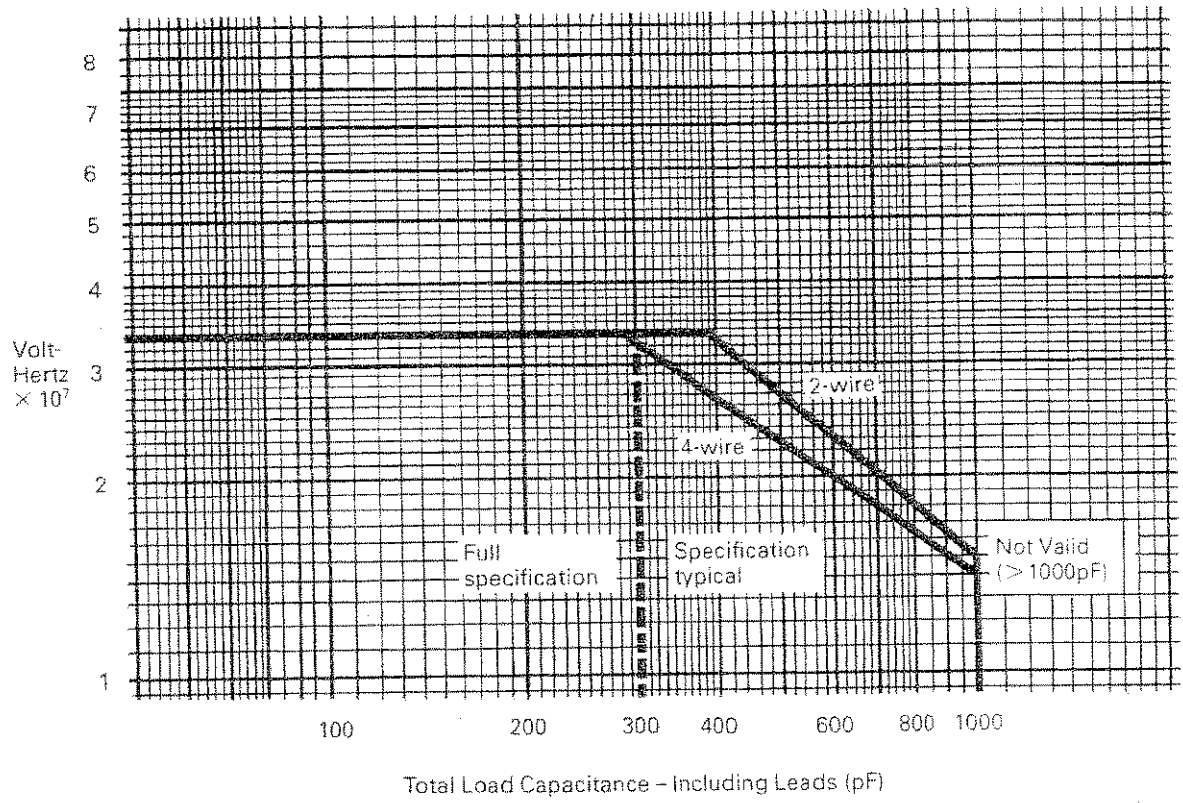



# DC CURRENT (Option 20)

## Accuracy

Range	Stability 24 hour $\pm$ (ppm OUTPUT + ppmFS) (1) (2)	Accuracy Relative to Calibration Standards $\pm$ (ppm OUTPUT + ppmFS) (2)			Calibration Uncertainty ( $\pm$ ppm) (3)	Temperature Coefficient ( $\pm$ ppm OUTPUT/ $^{\circ}$ C) 8 $^{\circ}$ C – 13 $^{\circ}$ C 33 $^{\circ}$ C – 38 $^{\circ}$ C	Output Resistance	Output Compliance
		24 hour 23 $^{\circ}$ C $\pm$ 1 $^{\circ}$ C	90 days 23 $^{\circ}$ C $\pm$ 1 $^{\circ}$ C	1 year 23 $^{\circ}$ C $\pm$ 10 $^{\circ}$ C				
100.0000 $\mu$ A	7+5	10+10	50+10	100+10	35	12	>2G $\Omega$	3V
1.000000mA	7+5	10+7	40+7	100+10	33	12	>2G $\Omega$	3V
10.00000mA	7+5	10+7	40+7	100+10	33	12	>200M $\Omega$	3V
100.0000mA	7+5	10+7	40+7	100+10	33	12	>20M $\Omega$	3V
1.000000A (4)	15+10	20+15	100+15	200+20	80	30	>1M $\Omega$	3V

## Noise

2.5kHz (RMS)	Bandwidth	
	Average Over 1 Line Period (pk-to-pk)	Average Over 10 Line Periods (pk-to-pk)
5nA	6nA	2nA
5nA	6nA	2nA
50nA	30nA	20nA
1 $\mu$ A	500nA	400nA
25 $\mu$ A	30 $\mu$ A	20 $\mu$ A

## Notes:

- (1) For same conditions between 18 $^{\circ}$ C and 28 $^{\circ}$ C.
- (2) FS=2xRange.
- (3) Factory calibration uncertainty using automated calibration equipment.  
Datron can provide better traceability. Contact factory for details.
- (4) Typical above 1A.

## Other Specifications

Output	True bipolar output capable of delivering $\pm$ 2A.
Overrange	100% on all ranges.
Settling Time	1s to full specification.
Local Sense Only, all ranges	
Max. reactive loads	100nF, 1mH (<1 $\mu$ s).



# DANGER HIGH VOLTAGE



**THIS INSTRUMENT IS CAPABLE  
OF DELIVERING  
A LETHAL ELECTRIC SHOCK!**



FRONT or REAR  
terminals carry the  
Full Output Voltage.

**THIS CAN KILL!**



Guard terminal is  
sensitive to over-  
voltage

**It can damage  
your instrument!**

Unless **you** are **sure** that  
it is **safe** to do so,  
**DO NOT TOUCH** the  
**I+ I- Hi or Lo leads**  
and **terminals**

# DANGER

# AC CURRENT (Option 20)

## Accuracy

Range	Frequency (Hz)	Stability 24 hour ±(ppm OUTPUT +ppm FS) (1) (2)	Accuracy Relative to Calibration Standards ± (ppm OUTPUT + ppm FS) (2)		
			24 hour 23°C + 1°C	90 days 23°C + 1°C	1 year 23°C + 10°C
100.0000μA	10-1k	50+20	400+80	400+80	500+100
	1k-5k	70+30	550+100 (7)	550+100 (7)	650+160 (7)
1.000000mA	10-1k	50+20	200+80	220+80	350+100
	1k-5k	50+20	350+80	350+80	450+100
10.000000mA	10-1k	50+20	200+80	220+80	350+100
	1k-5k	50+20	350+80	350+80	450+100
100.0000mA	10-1k	50+20	200+80	220+80	350+100
	1k-5k	50+20	350+80	350+80	450+100
1.000000A(4)	10-1k	50+20	400+80	400+80	500+100
	1k-5k	70+30	550+100 (7)	550+100 (7)	650+160 (7)

### Notes:

- (1) For same conditions between 18°C and 28°C.
- (2) FS=2x Range.
- (3) Factory calibration uncertainty using automated calibration equipment. Datron can provide better traceability. Contact factory for details.
- (4) Typical above 1 A.
- (5) Predominantly second harmonic (negligible error on mean sensing instruments).
- (6) For Frequency Range or Output Range changes, Function changes, OFF-ON changes, and Frequency changes between 31 and 32Hz: the Settling Times are doubled.
  - In remote operation via the IEEE 488 Interface, hardware switching occurs under the control of 'H' (Frequency) codes. Any transfer (up or down) between the undermentioned frequencies must be regarded as a frequency range change. Settling Time should be allowed as for Other Specifications.
 

31-32Hz	33.0-33.1kHz
300-301Hz	330-331kHz
3.00-3.01kHz	
  - For settling to 10ppm of Step Size, multiply all times by 1.5.
- (7) Assumes similar load time constant to that at calibration.

Calibration Uncertainty (ppm) (3)	Temperature Coefficient ( $\pm$ ppm OUTPUT $^{\circ}$ C 3 $^{\circ}$ C - 13 $^{\circ}$ C 33 $^{\circ}$ C - 43 $^{\circ}$ C)	Total Harmonic Distortion (%) (5)	Typical Output Impedance	Output Compliance
400	20	0.2	100M $\Omega$ *	3V rms
900	40	0.5		
255	20	0.2	30M $\Omega$	3V rms
255	20	0.2		
255	20	0.2	3M $\Omega$	3V rms
255	20	0.2		
255	20	0.2	300k $\Omega$	3V rms
255	20	0.2		
290	40	0.2	30k $\Omega$ **	3V rms
440	40	1.0		

\* Typical effective output capacitance = 200pF } Negligible on other Ranges  
 \*\* Typical effective output capacitance = 0.5 $\mu$ F }

### Other Specifications

Scale Length 9% to 200% of range, all ranges.  
 Settling Time (6) To 100ppm of step size (double for range changes):  
 10-32Hz < 10s  
 32-330Hz < 3s  
 > 330Hz < 1s  
 Frequency Accuracy <  $\pm$ 100ppm, typically 10ppm.  
 Maximum Load Capacitance 10nF (< 1 $\mu$ s).  
 Maximum Load Inductance 1mH (< 1 $\mu$ s).  
 Local Sense Only, all ranges.

# RESISTANCE (Option 20)

## Accuracy (2-wire or 4-wire sense)

Range (1)	Stability 24 hour $\pm$ (ppm OUTPUT +ppmFS) (1) (2)	* Accuracy Relative to Calibration Standards $\pm$ (ppm OUTPUT +ppmFS) (2)			Calibration Uncertainty (ppm) (3)	Temperature Coefficient ( $\pm$ ppm OUTPUT $^{\circ}$ C) 8 $^{\circ}$ C – 13 $^{\circ}$ C 33 $^{\circ}$ C – 38 $^{\circ}$ C	Specified Current (Is)	Maximum Current (Im)	Additional uncertainty for $I_s \leq I < I_m$ (ppm)
		24 hour 23 $^{\circ}$ C $\pm$ 1 $^{\circ}$ C	90 days 23 $^{\circ}$ C $\pm$ 1 $^{\circ}$ C	1 year 23 $^{\circ}$ C $\pm$ 10 $^{\circ}$ C					
		10.0000001 $\Omega$	6	8					
100.000001 $\Omega$	2.5	3	6	20	10	2	10mA	25mA	(8.5x10) $\Omega$
1.0000000k	2.5	3	6	20	10	2	1mA	10mA	(8.5x10) $\Omega$
10.000000k	2.5	3	6	20	10	2	100 $\mu$ A	2.5mA	(8.5x10) $\Omega$
100.00000k	2.5	3	6	25	20	2	100 $\mu$ A	1mA	(8.5x10) $\Omega$
1.0000000M	6	8	20	50	40	6	10 $\mu$ A	100 $\mu$ A	(10x10) $\Omega$
10.000000M	15	20	50	100	65	10	1 $\mu$ A	10 $\mu$ A	(15x10) $\Omega$
100.00000M	30	40	100	400	200	20	1 $\mu$ A	10 $\mu$ A	(15x10) $\Omega$

\* 2-wire Sense 24 Hrs and 90 days stability } 4-wire values  $\pm$ 0.1 $\Omega$   
 90 days accuracy }  
 1 year accuracy } 4-wire values  $\pm$ 0.2 $\Omega$

### Notes:

- (1) Range figures are nominal, actual calibrated values are displayed.
- (2) FS=2xRange.
- (3) Factory calibration uncertainty using automated calibration equipment.  
 Datron can provide better traceability. Contact factory for details.

### Other Specifications

- Connection: Selectable 2 or 4-wire connection to resistors.  
2-wire displayed value includes internal lead resistance.
- Guarding: Selectable remote or local guard connection.
- Protection: All resistors fuse protected to max applied voltage of 120V RMS.

# SECTION 7 SPECIFICATION VERIFICATION

## Introduction

The factory calibration of the 4700 ensures traceable accuracy to national standards. Figures of performance are quoted in the specifications of Section 6, related to time since calibration.

This section deals with user-verification of the 4700 performance to specification. It should be carried out as two independent verifications: DC specification and then AC specification.

## DC Specification Verification

### Verification upon receipt of a 4700 Autocal Multifunction Calibrator

Each instrument leaving the factory is calibrated to its nominal values in DC voltage. If Option 20 is fitted, it is also calibrated to nominal values in DC Current, and to actual values in Resistance. The Accuracy specifications can be made relative (i.e. Traceable) to National Standards, by the addition of Datron's Calibration Uncertainty figures printed in the specifications. Thus either the 90-day or 1-year accuracy specification is verifiable by comparison with traceable Reference Standards.

The 24-hour stability specifications can only be verified following a calibration operation or calibration check against the user's Reference Standards.

## Equipment Requirements

DC Voltage – A Standard DC Voltage source of suitable accuracy

Example: Series bank of 10 standard cells and Datron 4904 Standard Cell buffer.

– A Precision Divider

Example: Datron 4902 High Voltage divider and Datron 4903 DC Switching Unit

– A battery-operated null detector with variable sensitivity, able to withstand 1200V across its input terminals

Example: Keithley Instruments Model 155

DC Current – A DC Voltage source, calibrated to suitable accuracy at approximately 1V and 100mV.

Example: The standard voltage source used for DC Voltage, with the Datron 4903 DC Switching Unit.

– The battery-operated null detector used for DC Voltage.

– A set of calibrated current shunts of suitable accuracy.

### N.B.

To allow the same value to be set on the DC Voltage source for each range, the shunts may be of five decade values. Then the same Null Detector sensitivity can be used on each range.

### CAUTION

When choosing a set of current shunts ensure that their power dissipation ratings are sufficient to avoid permanent degradation from the self-heating effects of the current being checked. This applies particularly to the 1 Amp shunt.

– alternatively, a DMM of sufficient accuracy may be used to measure the voltage across the set of calibrated current shunts.

Example: Datron 1081 using "compute" mode.

Resistance – a set of standard resistors covering 10 $\Omega$  to 100M $\Omega$ . The 10 $\Omega$  to 10k $\Omega$  should be 4-wire type:

– an accurate resistance bridge, or other ratiometric device for measuring resistance to the required accuracy.

– a Datron 1081 used as a transfer measurement device.

## Notes on the Use of the Null Detector

The null detector is connected in the **Hi** lead between the DC Voltage Source and the 4700. A high-input-impedance device should be chosen to reduce off-null currents due to differences in the outputs of the DC voltage source and the 4700. A battery-operated instrument is preferred to ensure adequate isolation. Some null detectors possess high input impedance only when their readings are on-scale, so care should be taken to ensure that drain currents from the DC Voltage source do not become excessive. This applies particularly if the DC source is a standard cell or a bank of cells. Five points are important:

1. The null detector should be connected to the 4700 (or 4700 load resistor in Current function) only when the 4700 **OUTPUT OFF LED** is lit. (With Output **OFF**, the **I+**, **I-**, **Hi** and **Lo** terminals are at high impedance).
2. Always set the null detector to its lowest sensitivity before connecting up, and increase sensitivity only when the voltages output by the DC Voltage source and the 4700 are close in value.
3. Do not change polarity of the 4700 or DC Voltage source without first switching the 4700 **OUTPUT OFF**. Care must be taken to ensure that the correct-polarity **ON** key is pressed, to avoid excessive voltages being connected across the null detector, particularly when checking the 4700 directly against a standard cell.
4. **WARNING** During Performance checks and calibration a common mode voltage equal to the full range voltage is present at the Null Detector input terminals. On  $\pm 1000\text{V}$  checks this voltage is potentially lethal, so **EXTREME CAUTION** must be observed when making adjustments to the null detector sensitivity.
5. **CAUTION** The Null Detector used must be able to withstand voltages up to 1200V between its input terminals. Such voltages will be present during the time that the 4700 is ramping from zero to 1000V Full Range after setting **OUTPUT ON**.

## Specification Verification Report Sheet

The verification procedures in this section use the **+Lim** and **-Lim** facilities of **Spec** mode, so a written table of tolerance limits is unnecessary. In most cases, users will wish to verify against Reference Standards at non-cardinal values, so a table of Full Range limits would have little value.

Instead of Limit tables, a Report Sheet is provided later. This can be used for recording the results of verifying any of the three stored specifications. Spaces are provided to record the displayed limits as well as the measured values. The sheet may be used as a master to generate duplicate copies for future use.

### Stored Specifications

Three specifications are stored within each 4700 instrument's non-volatile memory:

24-hour accuracy,  
90-day accuracy + Datron's Calibration  
Uncertainty  
1 year accuracy + Datron's Calibration  
Uncertainty

These are selectable by the **CALIBRATION INTERVAL** switch on the rear panel, and are accessible to users by selecting 'Spec' mode (Refer to Sections 3 and 4). Thus 'Spec' mode provides tolerance and limit figures which are traceable to National Standards.

### 4700 Tolerance Limits

The 'Spec' mode 24-hour accuracy limits are computed from their specifications in Section 6. The displayed 90-day and 1-year accuracy limits for the 4700 are given at  $23^{\circ}\text{C} \pm 1^{\circ}\text{C}$  and  $23^{\circ}\text{C} \pm 10^{\circ}\text{C}$  respectively. They include Datron's calibration uncertainty, but not the user's calibration uncertainty. This should be taken into account if appropriate.

### Non-Verification

If an instrument is found to be out of specification, refer to the Routine Autocalibration in Section 8, or contact your nearest Datron Servicing Center.

**N.B.** It is recommended that the Blank Report Sheets be duplicated to give copies for future use.

## Verification Procedures

A full verification should be carried out in the sequence appearing on the Specification Verification Report Sheet. The instructions which follow are divided into 4 procedures:

- DC Voltage Full Range
- DC Voltage Linearity (10V Range only)
- DC Current Full Range
- Resistance

The displayed limits do not include temperature-coefficient corrections or the user's calibration uncertainties which should be taken into account if this is appropriate.

### 4700 DC Voltage Performance

**CAUTION:** First read the notes on the use of the Null Detector (page 7-2).

1. Turn on the instrument to be checked and allow a minimum of 4 hours to warm-up in the specified environment.
2. Cancel any MODE keys, set OUTPUT OFF and check that cal is not present on the MODE display.
3. Select Test to carry out the test routine described in Section 4. Terminate the test routine.
4. Select DC and connect the DC Voltage source and Null Detector to the 4700 Hi and Lo terminals as shown. Use short leads.
  - (a) Low Voltage. 100 $\mu$ V — 10V Ranges

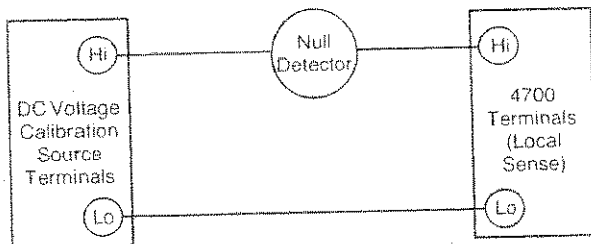

(b) High Voltage : 100V and 1000V Ranges

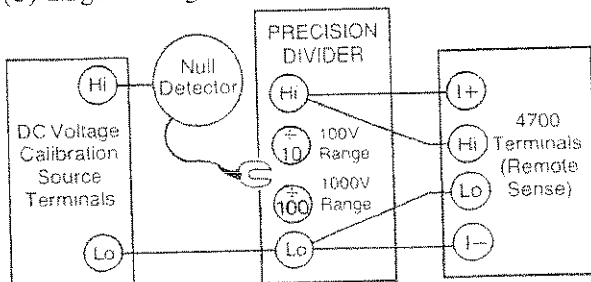

Turn to the voltage source down to zero and allow the circuit to stabilize thermally.

- N.B.** When changing polarity during the checks; if leads are reversed it will be necessary to allow time for thermal effects to stabilize in the reversed connection before proceeding with the check.

#### 5. Full Range Checks

Press Spec Key, check each range in turn in the following order to reduce the stabilization time for thermal effects at the terminals:  
 $\pm 100\mu\text{V}$ ,  $\pm 1\text{mV}$ ,  $\pm 10\text{mV}$ ,  $\pm 100\text{mV}$ ,  $\pm 1\text{V}$ ,  $\pm 10\text{V}$ ,  $\pm 100\text{V}$ ,  $\pm 1000\text{V}$ .

The checks may be carried out either at Full Range voltage or at a user's Reference standard voltage close to Full Range. For each check use the routine detailed in para 7. Use Report Sheet Table 1a to record the results.

#### 6. Linearity Check

This is performed on the 10V range. Press Spec Key. Check each pair of values in turn in the following order to reduce the stabilization time for thermal effects at the terminals:  
 $\pm 10\text{mV}$ ,  $\pm 100\text{mV}$ ,  $\pm 1\text{V}$ ,  $\pm 10\text{V}$ ,  $\pm 19\text{V}$ .

The checks may be carried out either at the above values or at user's Reference standard voltages close to the above values. For each check use the routine detailed in para 7. Use Report Sheet Table 1b to record the results.

7. To check each value against its specification limits use the following routine:

- a) Null Detector Set to low sensitivity.
- b) 4700 Switch OUTPUT OFF
- c) DC Voltage Source Set to correct polarity and voltage.
- d) 4700 Select DC and correct RANGE
- e) 4700 Use OUTPUT  $\uparrow\downarrow$  keys to set correct polarity and voltage on OUTPUT display.

Press +Lim: Record the displayed positive limit.  
 Press -Lim: Record the displayed negative limit.



- f) 4700 Press the correct-polarity ON Key.  
**CAUTION.** Pressing the wrong ON Key will result in approximately twice the OUTPUT voltage being connected across the null detector.
- g) Null Detector Increase sensitivity to give an off-null reading and use 4700  $\uparrow/\downarrow$  keys to back off to null, until the null lies between two consecutive values of the OUTPUT voltage least-significant digit.
- h) 4700 OUTPUT display Record the value closest to null and check against the specification limits.

An output voltage of 1V from the DC Voltage source now represents full range values of 4700 Output current, except on 1A range where self-heating is reduced by using an output voltage of 100mV.

Turn the DC Voltage source down to zero and allow the circuit to stabilize.

### 3. Full Range checks

Press Spec Key. Check each range in turn, in the following order to reduce thermal stabilization time:

$\pm 100\mu\text{A}$ ,  $\pm 1\text{mA}$ ,  $\pm 10\text{mA}$ ,  $\pm 100\text{mA}$ ,  $\pm 1\text{A}$ .

These checks may be carried out either at Full Range current or at a value close to full-range represented by a user's Reference standard voltage. For each check use the routine detailed in para 4. Use Report Sheet Table 2 to record the results.

4. To check each value against its specification limits use the following routine:

- a) Null Detector Set to low sensitivity.
- b) 4700 Switch OUTPUT OFF.
- c) DC Voltage source Set to correct polarity and voltage.
- d) 4700 Select I and correct RANGE.
- e) 4700 Use OUTPUT keys to set correct polarity and current on OUTPUT display.

Press +Lim: Record the displayed positive limit.  
 Press -Lim: Record the displayed negative limit.  
 Press the correct-polarity ON key and allow 5 minutes to stabilize.

**CAUTION:** Pressing the wrong ON key can result in approximately twice the DC voltage source output voltage being connected across the null detector.

- g) Null Detector Connect to the shunt terminal. Increase sensitivity to give an off-null

## 4700 DC Current Performance

1. Carry out the DC Voltage performance checks 1 to 3 if the DC voltage performance has not been verified.
2. Select DC and then I and connect the DC Voltage source, null detector and calibrated current shunt to the 4700 I+ and I- terminals as shown below. Do not connect null detector to shunt yet.

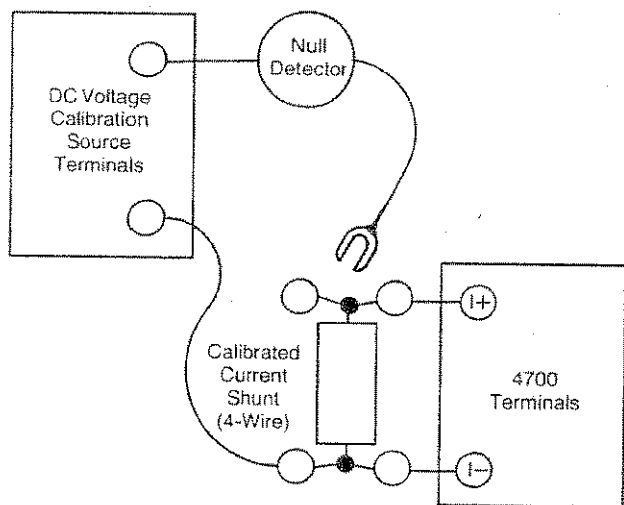

Preferred shunt values are as follows:

100 $\mu\text{A}$ range	—	10k $\Omega$	1mW min
1mA range	—	1k $\Omega$	10mW min
10mA range	—	100 $\Omega$	100mW min
100mA range	—	10 $\Omega$	1W min
1A range	—	0.1 $\Omega$	1W min

reading and use 4700  $\uparrow$   $\downarrow$  keys to back off to null again. Continue increasing sensitivity and backing off until the null lies between two consecutive values of the OUTPUT display least-significant digit. Ensure that the null obtained is stable.

- h) 4700 OUTPUT display Record the value closest to null and check against the specification limits.
- j) Null Detector Set to low sensitivity. Disconnect from the shunt terminal.
- k) DC Voltage source Set output to zero.
- l) 4700 Switch OUTPUT OFF.

## 4700 Resistance Performance

1. Carry out the DC Voltage performance checks 1 to 3 if the DC Voltage performance has not been verified.
2. For each resistance (RANGE) selection, three checks are required:
  - a) Remote Sense (4-wire) at Full Range (Resistor Value).
  - b) Local Sense (2-wire) at Full Range (Resistor plus internal wiring).
  - c) Local Sense (2-wire) at Zero (internal wiring only).

The displayed values were obtained at the most recent calibration, except 10M $\Omega$  and 100M $\Omega$  zero and Full Range in Local Sense which are the same as in Remote Sense.
3. For each verification check, the measured value should lie between the 90-day specification limits taken about the displayed value. The upper and lower test limits should be determined using Spec mode and secondary modes +Lim and -Lim, with the CALIBRATION INTERVAL switch on the rear panel set to 90-day (see Section 4 for operation of Spec mode). Space to record these limits, is reserved in Table 3 (Resistance) on the Specification Verification Report Sheet.

**N.B.** It is assumed that the specified energizing currents will be used to verify the resistance specification, so the displayed limits have been

calculated directly from the specification figures in Section 6 and are not modified by accuracy derating factors. The displayed limits refer to the 90-day Accuracy specification. The Stability specification should only be referred to, when checking against the same standard used for the previous calibration.

### 4. Press Spec Key.

Carry out the checks in the order listed in Table 3 (Resistance) on the Verification Report Sheet, to minimize waiting time for thermal stabilization.

Perform each check in the following order:

Set 4700 OUTPUT OFF.

Select resistor value (RANGE Key). (If Local Zero press OUTPUT Zero Key).

Select Local/Remote Sense (OUTPUT must be OFF).

Record OUTPUT displayed value on Table 3.

Press +Lim and record value on Table 3.

Press -Lim and record value on Table 3.

Connect measuring equipment (2-wire to Hi and Lo Terminals, or 4-wire energizing current to I+ and I- Terminals, voltage measurement across Hi and Lo Terminals).

Set 4700 OUTPUT ON.

Measure Resistance value and record on Table 3.

Check that this value is between +Lim and -Lim values recorded.



# DANGER HIGH VOLTAGE



**THIS INSTRUMENT IS CAPABLE  
OF DELIVERING  
A LETHAL ELECTRIC SHOCK!**



FRONT or REAR  
terminals carry the  
Full Output Voltage.

**THIS CAN KILL!**



Guard terminal is  
sensitive to over-  
voltage

**It can damage  
your instrument!**

Unless **you** are **sure** that  
it is **safe** to do so,  
**DO NOT TOUCH** the  
**I+ I- Hi or Lo leads**  
and **terminals**

# DANGER

# MODEL 4700 VERIFICATION REPORT SHEET. RS1

(Use as master for duplicate copies)

Serial Number \_\_\_\_\_ Date \_\_\_\_\_  
 Checked by \_\_\_\_\_ Company/Dept. \_\_\_\_\_

- Note: 1. The comparison between OUTPUT display readings for null and the Spec Mode Limits is Valid if zero errors have first been nulled out.  
 2. DC Current & Resistance table on reverse

## 1 DC Voltage

### a. Full Range Checks

Polarity/ Range	DC Calibration Source Voltage	Spec Mode Limits		OUTPUT display reading for null
		+Lim	-Lim	
+ 100 $\mu$ V				
- 100 $\mu$ V				
+ 1mV				
- 1mV				
+ 10mV				
- 10mV				
+ 100mV				
- 100mV				
+ 1V				
- 1V				
+ 10V				
- 10V				
+ 100V				
- 100V				
+1000V				
-1000V				

### b. 10V Range Linearity

Polarity/ nominal value	DC Calibration Source Voltage	Spec Mode Limits		OUTPUT display reading for null
		+Lim	-Lim	
+ 10mV				
- 10mV				
- 100mV				
+ 100mV				
+ 1V				
- 1V				
- 10V				
+ 10V				
+ 19V				
- 19V				

2 DC Current: Full Range Checks

Polarity/ Range	Shunt Value	DC Calibration Source Voltage	Spec Mode Limits		OUTPUT display reading for null
			+Lim	-Lim	
+ 100 $\mu$ A					
- 100 $\mu$ A					
+ 1mA					
- 1mA					
+ 10mA					
- 10mA					
+ 100mA					
- 100mA					
+ 1A					
- 1A					

3 Resistance: Value Measurements

Method used \_\_\_\_\_

Range/Sense	Specified Current	Current Used	Displayed Value	Spec Mode		Measured Value
				+Lim	-Lim	
100M $\Omega$ Remote	1 $\mu$ A					
Local						
Local Zero						
10M $\Omega$ Remote	10 $\mu$ A					
Local						
Local Zero						
1M $\Omega$ Remote	100 $\mu$ A					
Local						
Local Zero						
100k $\Omega$ Remote	100 $\mu$ A					
Local						
Local Zero						
10k $\Omega$ Remote	1mA					
Local						
Local Zero						
1k $\Omega$ Remote	10mA					
Local						
Local Zero						
100 $\Omega$ Remote	10mA					
Local						
Local Zero						
10 $\Omega$ Remote	100mA					
Local						
Local Zero						

## AC Specification Verification

### Choice of Verification Method

The wide dynamic range of the 4700 makes it necessary to employ different verification methods for different groups of output and frequency ranges.

For instance: The most common method of verifying AC Voltage outputs is to check against an accurate DC Voltage Standard via a Thermal Transfer. However, available thermal transfer standards are not suitable for direct verification of the millivolt ranges, because their transfer elements are insufficiently sensitive.

Naturally, the range, accuracy and traceability of users' standards governs the degree to which the performance of any new equipment can be verified. This is especially true for the 4700, in view of the range of the parameters to be checked.

This section describes a recommended method of verifying each of the parameters listed below. Where appropriate, alternative methods are described in Appendices to the section.

### Parameters to be Verified, with Recommended Methods

The following list of parameters is grouped according to the type of equipment suitable for verification.

#### 1. Voltage Ranges (1V to 1000V)

- a. Full Range values are verified at LF and HF by direct thermal transfer against a DC Voltage Standard.

and

- b. Instrument Linearity is verified at 1V, 10V and 19.99999V on the 10V range at LF, using the same method.

#### 2. Millivolt Ranges (1mV to 100mV).

Full Range values are verified as follows:

- a. At LF:  
Commercially available Inductive Voltage Divider (IVD) and standardized DVM Transfer. (Such IVDs are normally only suitable for LF verification, up to about 5kHz).

and

- b. at HF:  
A 100% to 10% of Range Transfer method, after verifying 10V range HF linearity and 1V HF Full Range value. A DVM is standardized and corrected for linearity error, then used as a transfer standard. The method is described later in this section.

An alternative method is described at Appendix 2 for users in possession of a Wideband (to 100kHz) Inductive Voltage Divider (WIVD).

#### 3. Current Ranges (1mA to 1A).

- a. 10mA, 100mA and 1A Full Range values are checked using a Thermal Transfer Standard fitted with standard shunts at LF and HF, against a DC Current Standard.

and

- b. The 1mA Full Range value can be checked using the same method, provided that low-current shunts for the thermal transfer standard are available.

Alternatively, if calibrated AC current shunts are available, the Current Ranges can be verified by voltage measurement, using an AC DVM, as described in Appendix 3.

#### Fixed or Adjustable Voltage Standard?

Many users who are able to verify AC Voltage and Current to the accuracy required for the 4700, will also have access to an adjustable DC Voltage Standard as Reference. In these cases their 4700 can be verified at cardinal values. For users with fixed DC Voltage Standards only, the 4700 can be verified at non-cardinal values directly or by using the 4700 'Error Mode'. In both cases users will need to calculate the effects of their own Standards' uncertainty, so calculations for total tolerance limits are given in Appendix 4.

## Summary of Equipment Requirements

This summary relates to the recommended method of verifying the 4700. Alternative methods, with the required equipment, are described in appendices.

### AC VOLTAGE (1V – 1000V Full Range Values and 10V Range Linearity)

An Adjustable DC Voltage Source of suitable accuracy.

#### Example:

Datron 4000 or 4000A Autocal Standard.

An AC/DC Thermal Transfer Standard capable of operating over the range 1V to 1100V RMS.

### AC MILLIVOLTS

(1mV – 100mV Full Range Values)

at LF:

A commercially-available Inductive Voltage Divider tapped at 10:1, 100:1 and 1000:1 of suitable accuracy and frequency response.

at HF:

The 4700 under test with the correction figure for 10% of its 10V Range at HF.

The DC Voltage Source used for 1V – 1000V ranges.

and at both LF and HF:

The AC/DC Thermal Transfer used for 1V – 1000V ranges.

A DVM of suitable accuracy and frequency response.

**Example:**

Datron 1081 or similar.

## AC CURRENT (1mA – 1A Full Range Values)

A DC Current Source of suitable accuracy and an AC/DC Thermal Transfer together with a set of Calibrated Thermal Transfer Current Shunts of suitable accuracy.

For the alternative method at Appendix 3, a set of calibrated AC Current Shunts of suitable value and accuracy.

## Summary of Verification Procedures

### 1. Full Range Voltage (1V – 1000V Ranges)

#### Adjustable DC Standard

The 4700 is connected up and set to output a Full Range voltage at the required frequency. The Thermal Transfer is nulled against the 4700 Full Range voltage. The DC Standard is adjusted to null with the Thermal Transfer, and its output voltage recorded. Its uncertainty is also recorded, and the Tolerance Limits calculated. The 4700 is verified if the DC voltage is within the tolerance limits.

Details of the procedure are on page 7-12.

#### Fixed DC Standard

The Thermal Transfer is nulled against the DC Standard, and its fixed voltage is recorded on the Report Sheet. The 4700 **OUTPUT** display is set to this voltage, the **Spec Mode** tolerance is recorded, and the **Tolerance Limits** are calculated. The 4700 output voltage is adjusted to null with the Thermal

Transfer, and its displayed voltage is recorded and checked against the tolerance limits.

See Appendix 1 for the procedure.

### 2. Linearity (Performed on 10V Range)

This should be checked at 1V, 10V and 19.99999V in turn, or at user's Reference standard voltages close to the above values. Similar techniques are used as for Full Range voltages. For each check the results are recorded.

See page 7-12 or Appendix 1 for the procedure.

### 3. Full Range Voltage (1mV – 100mV Ranges)

#### Method 1

At LF, the 1V Full Range value is first verified using thermal transfer, then this voltage is divided via the standard IVD to standardize an AC DVM at the millivolt Full Range value. The 4700 millivolt range is then verified at this standardized value by DVM measurement.

See page 7-13 for the procedure.

At HF, the 4700 is set to the 10V Range. Outputs are measured at 10V and 1V using thermal transfer, and a linearity correction factor is calculated for the 1V output.

The 1V Range is selected with output set to 100mV at HF. The output setting is changed by the correction factor and the output is used to standardize the AC DVM.

The 100mV Range is selected at HF Full Range, and the output measured on the DVM. The 100mV Full Range value verifies if the DVM reading is the corrected value, plus or minus the specified tolerances.

The DVM is standardized again at 10mV on the 100mV Range, and used to verify the 10mV Full Range in the same way. The process is repeated to verify the 1mV Range.

See page 7-14 for the procedure.

#### Method 2

At both LF and HF, the 1V Full Range value is first verified using thermal transfer, then this voltage is divided via the wideband IVD to standardize an AC DVM at the millivolt Full Range value. The 4700 millivolt range is then verified at this standardized value by DVM measurement.

See Appendix 2 for the procedure.

**4. Full Range Current (using Standard Shunts)**  
 The Thermal Transfer Current Shunt is fitted to the Shunt Input of the Thermal Transfer Standard and the 4700 set to output a Full Range current into the shunt at the required frequency. The output current is split between the shunt and the transfer element. This is compared with the output from a Standard DC Current Source.

See Page 7-18 or Appendix 1 for the procedure.

**Alternative Method**

The 4700 is connected up and set to output a Full Range current into the calibrated AC Current Shunt at the required frequency. The 4700 Current output develops a voltage across the shunt which is measured by the AC DVM, with care taken not to load the shunt.

The procedure is detailed in Appendix 3.

## Specification Verification Procedures

**Preparation**

Before attempting any verification ensure the following steps are carried out.

1. Turn on the instrument to be checked and allow a minimum of 2 hours to warm-up in the specified environment.
2. Ensure familiarity with normal operation as described in this Handbook.
3. Cancel any MODE Keys, ensure OUTPUT OFF and check that 'cal' is not present on the MODE display. (If 'cal' is present, turn the Calibration Keyswitch on the Rear Panel to its RUN position).
4. Self-Test: select Test to carry out the test routine described in Section 4. Terminate the test routine.
5. Consult the manufacturer's handbooks before connecting and operating any equipment in the measurement system.
6. Interconnections and Guarding: Refer to Section 4 page 4-1.
7. Select 24hr, 90dy or 1yr on the CALIBRATION INTERVAL Switch. Refer to Section 4 page 4-10.

<b>Index of Recommended Procedures</b> (using adjustable DC Voltage Standard)	<b>Page</b>
<b>Voltage Ranges (1V to 1000V)</b>	
a. Full Range Values	7-12
b. Instrument Linearity (10V Range)	7-12
<b>Millivolt Ranges (1mV to 100mV)</b>	
a. LF	7-13
b. HF	7-14
<b>Current Ranges (1mA to 1A)</b>	7-18
<b>Report Sheet RS2</b>	7-19
<b>Alternative Procedures</b>	Appendix
<b>As Recommended but using Fixed DC Voltage Source (with Report Sheet RS3)</b>	1
<b>Millivolt Checks using Wideband IVD</b>	2
<b>Current Checks using Calibrated AC Shunts</b>	3
<b>Total Tolerance Limit Calculations</b>	4
<b>Uncertainty and Traceability</b>	5
<b>General Procedural Information</b>	6
<b>Harmonic Distortion Measurement</b>	7



# AC Voltage Verification Procedure

(Using Adjustable DC Voltage Calibration Standard)

Record Results on Report Sheet RS2 (page 7-19)

Full Range Checks (1V – 1000V)

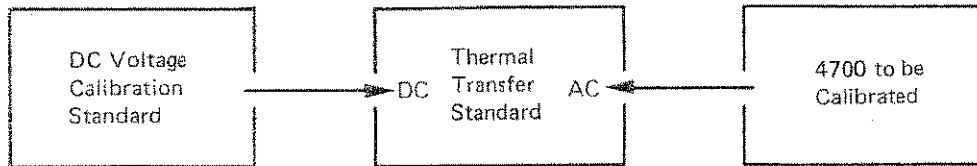

## WARNING

**THE TERMINALS MARKED WITH THE SYMBOL CARRY THE OUTPUT OF THE 4700. THESE TERMINALS AND ANY OTHER CONNECTIONS TO THE LOAD UNDER TEST COULD CARRY LETHAL VOLTAGES. UNDER NO CIRCUMSTANCES SHOULD USERS TOUCH ANY OF THE FRONT (OR REAR) PANEL TERMINALS UNLESS THEY ARE FIRST SATISFIED THAT NO DANGEROUS VOLTAGE IS PRESENT.**

- a. With OUTPUT OFF, connect the DC Voltage Standard to the Thermal Transfer DC input. Use 4-wire connection and Remote Sense if available.
- b. With OUTPUT OFF, connect the 4700 to the Thermal Transfer AC input. Use 4-wire connection and Remote Sense.
- c. Configure the Thermal Transfer for AC measurement at the required voltage.
- d. Set the 4700 OUTPUT Range, Voltage and Frequency (see Report Sheet RS2)
- e. Set 4700 OUTPUT ON, and null the Thermal Transfer to the 4700 AC OUTPUT.
- f. Configure the Thermal Transfer for DC nulling.
- g. Configure the DC Voltage Standard at the required voltage, set its OUTPUT ON and adjust its output to null the Thermal Transfer. Record its output voltage on Report Sheet RS2.
- h. Repeat (c) to (g) for all 4700 outputs on Report Sheet RS2 Table 1(a).

- j. Sum the Verification setup uncertainties and record in the Us column as voltage deviations. (Refer to Appendix 5).

For Total Tolerance Limit Calculations refer to Appendix 4 page 7-31, para 1.

- k. Calculate the Lower and Upper Total Tolerance Limits. Use Calculation A if the 4700 was last calibrated by Datron. Use Calculation B if the 4700 was last calibrated against the standards being used for verification.
- l. Each 4700 Full Range output is verified if the DC Voltage outputs recorded in (g) are at or between the corresponding Total Tolerance Limits.

## Linearity (10V Range)

- m. If the 10V Range verified correctly, repeat operations (c) to (g) for Report Sheet RS2 Table 1(b).
- n. If the 1V and 10V Ranges verified, proceed to AC Millivolt verification and AC Current verification.

## Millivolts (LF) Verification Procedure

(Using verified 4700 1V Range, Inductive Voltage Divider (IVD) and AC DVM).

Record results on Report Sheet RS2, Table 2(a)  
(Page 7-20).

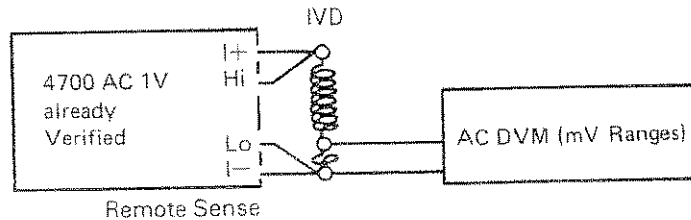

Standardization of DVM Millivolt Ranges

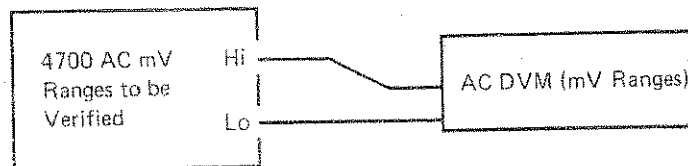

Verification of 4700 LF Millivolt Ranges

- a. With **OUTPUT OFF**, connect the 4700, IVD and DVM for Standardization. Set the IVD ratio to 1:10 and the AC DVM to measure 100mV.
- b. Set 4700 to 1V Range, 1kHz, and adjust for corrected 1.000000V output.
- c. Set 4700 **OUTPUT ON** and note the DVM reading as **V1**.
- d. Set 4700 **OUTPUT OFF**, and reconnect the test circuit for Verification.
- e. Set the 4700 **OUTPUT RANGE** to 100mV and adjust the **OUTPUT Display** to 100.0000mV.
- f. Set 4700 **OUTPUT ON** and adjust the **OUTPUT**  $\uparrow$ / $\downarrow$  keys for a DVM reading of **V1**.
- g. Record the 4700 **OUTPUT Display** setting in the last column of Report Sheet RS2 Table 2(a).
- h. Repeat (a) to (g), but setting the 4700, IVD ratio and DVM as required to verify the 10mV and 1mV Full Range outputs; still using the corrected 1V Full Range output in (b). Record the results on Report Sheet RS2 Table 2(a).
- i. The 4700 mV Full Ranges are verified if each of the 4700 **OUTPUT Display** settings recorded at (g) are at or between the corresponding Total Tolerance Limits.
- j. Sum the Verification setup uncertainties and record in the **Us** column as voltage deviations. (Refer to Appendix 5).

**Total Tolerance Limit Calculations** Refer to Appendix 4 page 7-31, para 1.

- k. Calculate the Lower and Upper Total Tolerance Limits:  
Use Calculation A if the 4700 was last calibrated by Datron.  
Use Calculation B if the 4700 was last calibrated against the standards being used for verification.

# Millivolts (HF) Verification

## Procedure

(Using verified 4700 AC 1V and 10V Ranges, 10% Range Correction Factor and AC DVM) Record results on Report Sheet RS2, Table 2(b) (Page 7-20).

### Full Range Checks (1mV — 100mV at 1MHz)

N.B. These verification checks are not fully traceable. The verified output values of 1V on the 1V Range; and 10V on the 10V Range are used to measure the 4700 linearity error at 1V on the 10V range. From the linearity measurement a 10% of range Linearity and Scaling factor 'C' is derived.

This factor is subsequently used to correct the 4700 output setting at 10% of range, to standardize a DVM for verification of the next range down.

### Interconnections

FIG 1 (10V and 1V Ranges)

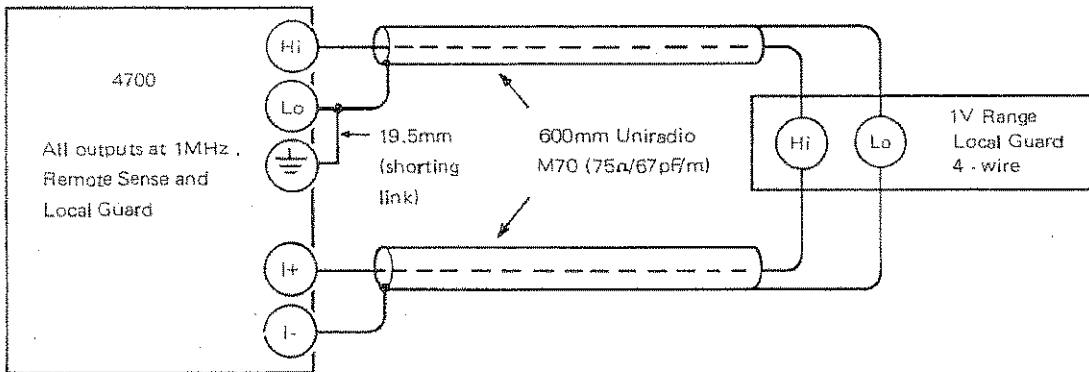
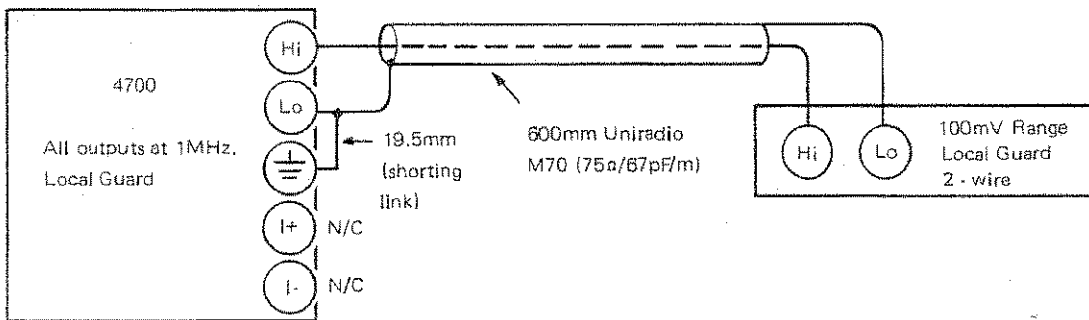

FIG 2 (100mV to 1mV Ranges)



Stage 1 Derive the Linearity and Scaling Factor 'C' as follows (C is a number of value close to 0.1):

- a. Ensure that the Millivolts (LF) Verification has been completed.

Ensure that the 4700 has been verified at 10V and 1V HF (1MHZ) Full Range (page 7-12). Record the measured values as follows:

4700 10V FR setting — 10.000,00V  
Actual output voltage — 'V1'

4700 1V FR setting — 1.000,000V  
Actual output voltage — 'V2'

- b. Calculate 1V correction 'V3' =  $\frac{1}{V2}$
- c. With OUTPUT OFF connect a DVM to the 4700 terminals using the exact 4-wire connections as in Fig. 1. Set the DVM to measure AC on its 1V range.
- d. On 4700, select the 1V range and Remote Sense.  
Set FREQUENCY to 1MHz.  
Set OUTPUT display reading to V3.  
Set OUTPUT ON, and note the DVM reading as 'Vt'.  
Set OUTPUT OFF.
- e. On 4700, select the 10V range (Remote Sense).  
Set 4700 OUTPUT display reading to 1V.  
Set OUTPUT ON.  
Adjust the OUTPUT display for DVM reading of Vt.
- f. Note the 4700 OUTPUT display reading as 'V4'.  
Set OUTPUT OFF.
- g. From the values V1 and V4 calculate the 10V range linearity correction and scaling factor 'C' as follows:

$$C = \frac{V1 \times V4}{100}$$

Note:

The optimum resolutions quoted above the boxes in this column may not be achievable with the DVM in use. In these cases it is permissible to reduce the resolution by a maximum of 1 digit only.

Record in 6½ digits resolution

V1 =
V2 =
V3 =

Vt is a transfer value

Vt =
------

Record in 6½ digits resolution

V4 =
------

Calculate in 6½ digits resolution

C =
-----

**Stage 2 To Verify the 100mV AC Range Full Range Output**

- a. Ensure that the DVM is still connected to the 4700 terminals as shown in Fig. 1.
- b. Set the 4700 to the 1V AC range.  
Calculate the value ' $V_3 \times C$ '.  
Set OUTPUT display to this value.
- c. Set the DVM to measure 100mV.
- d. Set the 4700 OUTPUT ON, allow the output to settle.  
Note the DVM reading as ' $V(100t)$ '.
- e. Set the 4700 OPUTPUT OFF and reconnect the DVM to the 4700 terminals in 2-wire as shown in Fig. 2.
- f. Set 4700 to its 100mV AC range.  
(Remote Sense is automatically deselected.)  
Set OUTPUT ON.  
Adjust the 4700 Output for a DVM reading of  $V(100t)$ .  
Note the 4700 OUTPUT display setting as ' $V(100m)$ '.  
  
Record this setting in the last column of RS2 table 2(b).

Calculate in  $6\frac{1}{2}$  digits resolution

$$V_3 \times C =$$

$V(100t)$  is a transfer value

$$V(100t) =$$

Record in  $6\frac{1}{2}$  digits resolution

$$V(100m) =$$

**Stage 3 To verify the 10mV AC Range Full Range Output**

- a. Ensure that the DVM is still connected to the 4700 terminals as shown in Fig. 2.
- b. Ensure that the 4700 is set to the 100mV AC range.  
Calculate the value ' $V(100m) \times C$ '.  
Set OUTPUT display to this value.
- c. Set the DVM to measure 10mV.
- d. Allow the output to settle.  
Note the DVM reading as ' $V(10t)$ '.
- e. Set 4700 to its 10mV AC range.  
Adjust the 4700 Output from a DVM reading of  $V(10t)$ .  
Note the 4700 OUTPUT display setting as ' $V(10m)$ '.  
  
Record this setting in the last column of RS2 table 2(b).

Calculate in  $6\frac{1}{2}$  digits resolution

$$V(100m) \times C =$$

$V(10t)$  is a transfer value

$$V(10t) =$$

Record in  $5\frac{1}{2}$  digits resolution

$$V(10m) =$$

**Stage 4 To Verify the 1mV AC Range Full Range Output**

- a. Ensure that the DVM is still connected to the 4700 terminals as shown in Fig. 2.
- b. Ensure that the 4700 is set to the 10mV AC range.  
Calculate to value ' $V(10m) \times C$ '.  
Set OUTPUT display to this value.
- c. Set the DVM to measure 1mV.
- d. Allow the output to settle.  
Note the DVM reading as ' $V(lt)$ '.
- e. Set 4700 to its 1mV AC range.  
Adjust the 4700 Output to give a settled DVM reading of  $V(lt)$ .  
Note the 4700 OUTPUT display setting as ' $V(1m)$ '.  
  
Record this setting in the last column of RS2 Table 2(b).

Calculate in 5½ digits resolution

$$V(10m) \times C =$$

$V(lt)$  is a transfer value

$$V(lt) =$$

Record in 4½ digits resolution

$$V(1m) =$$

**Stage 5 Verification Against Limits**

**For Total Tolerance Limit Calculations**  
Refer to Appendix 4 page 7-31 para 1.

- a. Sum the Verification setup uncertainties and record in the  $U_s$  column of RS2 Table 2(b) as voltage deviations. (Refer to Appendix 5).
- b. Calculate the Lower and Upper Total Tolerance Limits:  
  
Use Calculation A if the 4700 was last calibrated by Datron.  
  
Use Calculation B if the 4700 was last calibrated against the standards being used for verifications.
- c. Each 4700 mV Full Range (HF) is verified if the 4700 OUTPUT display settings ( $V(100m)$ ,  $V(10m)$  and  $V(1m)$ ), recorded in the last column of RS2 Table 2(b), are at or between their corresponding Wideband Calculated Tolerance Limits.

# AC Current Verification Procedure

(Using Thermal Transfer, Current Shunts and DC Current Standard).

Record results on Report Sheet RS2, Table 3 (Page 7-20).

## Full Range Checks (1mA – 1A)

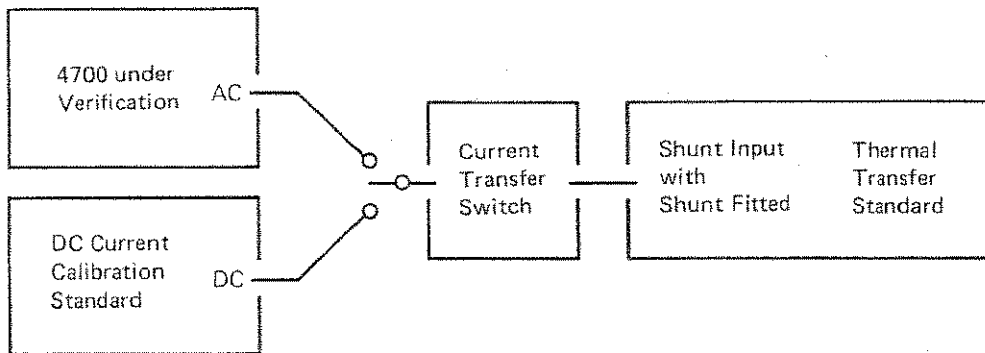

- a. With 4700 **OUTPUT OFF**, set the Function to AC and then I, **OUTPUT RANGE** to 10m, **OUTPUT Display** to 10.00000mA at a Frequency of 300Hz.
- b. Configure the Thermal Transfer for 10mA Current measurement and connect the appropriate shunt.
- c. With **OUTPUT OFF**, connect the 4700 I+ and I- terminals across the Shunt.
- d. Set 4700 **OUTPUT ON**, and null the Thermal Transfer to the 4700 AC **OUTPUT**. Set 4700 **OUTPUT OFF**.
- e. With **OUTPUT OFF**, configure the DC Current Standard for an output of 10mA, and connect across the Transfer Shunt.
- f. Set the DC Standard **OUTPUT ON** and adjust its output current to null the Thermal Transfer. Record its output current on Report Sheet RS2 Table3(a).
- g. Set 4700 Frequency to 5kHz, and repeat (c) to (f).
- h. Repeat (a) to (g), but for 4700 100mA and 1A Full Range outputs.
- j. If the Thermal Transfer has been adequately calibrated for 1mA transfers, repeat (a) to (g) for 4700 1mA Full Range outputs, recording the DC Standard output currents in Report Sheet RS2 Table 3(b).
- k. Sum the Verification setup uncertainties and record in the Us column as current deviations. (Refer to Appendix 5).

For Total Tolerance Limit Calculations refer to Appendix 4 page 7-31 Para 1.

1. Calculate the Lower and Upper Total Tolerance Limits.  
Use Calculation A if the 4700 was last calibrated by Datron.  
Use Calculation B if the 4700 was last calibrated against the standards being used for verification.
- m. Each 4700 Full Range output verifies if the DC Current outputs recorded in (f) are at or between the corresponding Total Tolerance Limits.

# MODEL 4700 VERIFICATION REPORT SHEET. RS2

RS2 - For Users with Adjustable DC Voltage Standards.

Serial Number \_\_\_\_\_ Date \_\_\_\_\_

Checked by \_\_\_\_\_ Company/Dept. \_\_\_\_\_

Note: - On receipt of the instrument it is recommended to check at the frequencies shown below.

## 1. AC VOLTAGE (Using Adjustable DC Voltage Standard via Thermal Transfer)

### a. 1V to 1000V Ranges.

4700 OUTPUT RANGE/ FREQUENCY	4700 Nominal OUTPUT Voltage	Wideband Relative Accuracy Tolerance Limits		Datron Cal. Std. Uncert'y ±Ud(Abs)	User's Cal. Std. Uncert'y ±Us (Abs)	Wideband Calculated Total Tolerance Limits		User's DC Standard value for Null
		Lower(Lr)	Upper(Ur)			Lower	Upper	
1V 1kHz	1.000000V	.999840	1.000160	0.000130V				
1V 1MHz	1.000000V	.994000	1.006000	0.001150V				
10V 1kHz	10.00000V	9.99840	10.00160	0.00130V				
10V 1MHz	10.00000V	9.94000	10.06000	0.01150V				
100V 1kHz	100.0000V	99.9840	100.0160	0.0130V				
100V 100kHz	100.0000V	99.9710	100.0290	0.0200V				
1000V 1kHz	1000.000V	999.750	1000.250	0.170V				
1000V 30kHz	1000.000V	999.650	1000.350	0.250V				

### b. Linearity (Performed on 10V Range)

10V 1kHz	1.00000V	0.99948	1.00052	0.00013V				
10V 1kHz	10.00000V	9.99840	10.00160	0.00130V				
10V 1kHz	19.00000V	18.00732	19.00268	0.00260V				



## 2. AC MILLIVOLTS 1mV to 100mV Ranges

### a. LF 1kHz (using Verified 1V Full Range, Inductive Voltage Divider and AC DVM)

4700 OUTPUT RANGE	4700 Nominal OUTPUT Voltage	Wideband Relative Accuracy Tolerance Limits		Datron Cal. Std. Uncert'y $\pm U_d$ (Abs)	User's Cal. Std. Uncert'y $\pm U_s$ (Abs)	Wideband Calculated Total Tolerance Limits		4700 OUTPUT Display Setting
		Lower (Lr)	Upper (Ur)			Lower	Upper	
100mV	100.0000mV	99.9620	100.0380	0.0350mV				
10mV	10.0000mV	9.9872	10.0128	0.0125mV				
1mV	1.0000mV	.9897	1.0103	0.0103mV				

### b. HF 1MHz (Using Verified 1V and 10V Full Range, 10% Range Correction and AC DVM)

100mV	100.0000mV	98.9700	101.0300	0.1420mV				
10mV	10.0000mV	9.8700	10.1300	0.0250mV				
1mV	1.0000mV	.9600	1.0400	0.0138mV				

## 3. AC CURRENT

### a. 10mA to 1A Ranges. (Using Thermal Transfer, Current Shunts and DC Current Standard)

4700 OUTPUT RANGE/ FREQUENCY	Transfer Shunt Value	Wideband Relative Accuracy Tolerance Limits		Datron Cal. Std. Uncert'y $\pm U_d$ (Abs)	User's Cal. Std. Uncert'y $\pm U_s$ (Abs)	Wideband Calculated Total Tolerance Limits		User's DC Standard value for Null
		Lower (Lr)	Upper (Ur)			Lower	Upper	
10mA 300Hz		9.99620	10.00380	0.00255mA				
10mA 5kHz		9.99490	10.00510	0.00255mA				
100mA 300Hz		99.9620	100.0380	0.0255mA				
100mA 5kHz		99.9490	100.0510	0.0255mA				
1A 300Hz		.999440	1.000560	0.000290A				
1A 5kHz		.999250	1.000750	0.000440A				

### b. 1mA Range. (If Thermal Transfer is calibrated at this level)

1mA 300Hz		.999620	1.000380	0.000255mA				
1mA 5kHz		.999490	1.000510	0.000255mA				

## APPENDIX 1

# VERIFICATION PROCEDURES FOR USERS WITH FIXED DC VOLTAGE STANDARDS

## AC Voltage Verification Procedure

(Using Fixed Voltage DC Calibration Standard).  
Record results on Report Sheet RS3 (Page 7-25).

### Full Range Checks (1V – 1000V)

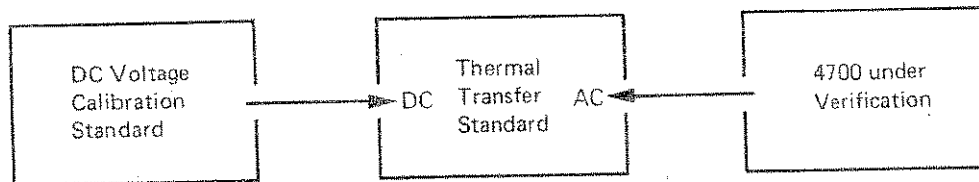

**WARNING**  
THE TERMINALS MARKED WITH THE  SYMBOL CARRY THE OUTPUT OF THE 4700. THESE TERMINALS AND ANY OTHER CONNECTIONS TO THE LOAD UNDER TEST COULD CARRY LETHAL VOLTAGES. UNDER NO CIRCUMSTANCES SHOULD USERS TOUCH ANY OF THE FRONT (OR REAR) PANEL TERMINALS UNLESS THEY ARE FIRST SATISFIED THAT NO DANGEROUS VOLTAGE IS PRESENT.

- a. With OUTPUT OFF, connect the DC Voltage Standard to the Thermal Transfer DC input. Use 4-wire connection and Remote Sense if available.
- b. With OUTPUT OFF, connect the 4700 to the Thermal Transfer AC input. Use 4-wire connection and Remote Sense.
- c. Configure the Thermal Transfer for DC measurement at the required voltage.
- d. Set the DC Voltage Standard to the required voltage, OUTPUT ON, and null the Thermal Transfer to its output. Record its output voltage on Report Sheet RS2 Table 1(a) as '4700 Required OUTPUT Voltage'.
- e. Configure the Thermal Transfer for AC measurement at the required voltage.
- f. Set 4700 OUTPUT ON, and adjust its OUTPUT Display reading to null on the Thermal Transfer.
- g. Record the '4700 OUTPUT Display Reading for Null' on Report Sheet RS3 Table 1(a).
- h. Ensure that the 4700 CALIBRATION INTERVAL switch is set to 90dy. Press the 4700 Spec key and record the MODE Display reading in ppm as ' $\pm U_r$  ppm'. Press the Spec key again to cancel.
- i. Obtain the Datron Calibration Uncertainty from Section 6 for the 4700 output, and record as ' $\pm U_d$  ppm'.
- k. Repeat (c) to (j) for required voltages close to all 4700 outputs on Report Sheet RS3 Table 1(a).
- l. Sum the Verification setup uncertainties and record as ' $\pm U_s$  ppm'. (Refer to Appendix 5).

**Total Tolerance Limit Calculations**  
See Appendix 4 page 7-31 Para 2.

- m. Calculate the Lower and Upper Total Tolerance Limits.  
Use Calculations A and C if the 4700 was last calibrated by Datron.  
Use Calculations B and C if the 4700 was last calibrated against the standards being used for verification.

- n. Each 4700 Full Range is verified if the AC Voltage outputs recorded in (h) are at or between the corresponding Total Tolerance Limits.

**Linearity**  
(10V Range)

- p. If the 10V Range verified correctly, repeat the procedure for Report Sheet RS3 Table 1(b).
- q. If the 1V Range verified correctly, proceed to AC Millivolt verification and AC Current (option 20) verification.

## **Millivolt (LF) Verification Procedure**

(Using Verified 4700 1V Range, Inductive Voltage Divider (IVD) and AC DVM)  
Record results on Report Sheet RS3, Table 2(a)  
(Page 7-26)

### **Full Range Checks (1mV – 100mV)**

This procedure uses the same equipment, following the same steps as on page 7-13.

However, because the 1V Range was verified at the User's Standard voltage, standardization of the DVM and verification of Full Range values takes place at sub-multiples of that voltage.

## **Millivolt (HF) Verification Procedure**

(Using verified 4700 1V and 10V Ranges, 10% Range Correction Factor and AC DVM)  
Record results on Report Sheet RS3, Table 2(b)  
(Page 7-26).

### **Full Range Checks (1mV – 100mV at 1MHz)**

This procedure uses the same equipment, following the same steps as on page 7-14.

However, because the 1V and 10V Ranges were verified at the User's Standard voltages, calculation of the correction factor, standardization of the DVM and verification of Full Range values takes place at sub-multiples of those voltages.

# AC Current Verification Procedure

(Using Thermal Transfer, Current Shunts and DC Current Standard)

Record Results on Report Sheet RS3, Table 3 (Page 7-26).

## Full Range Checks (1mA - 1A)

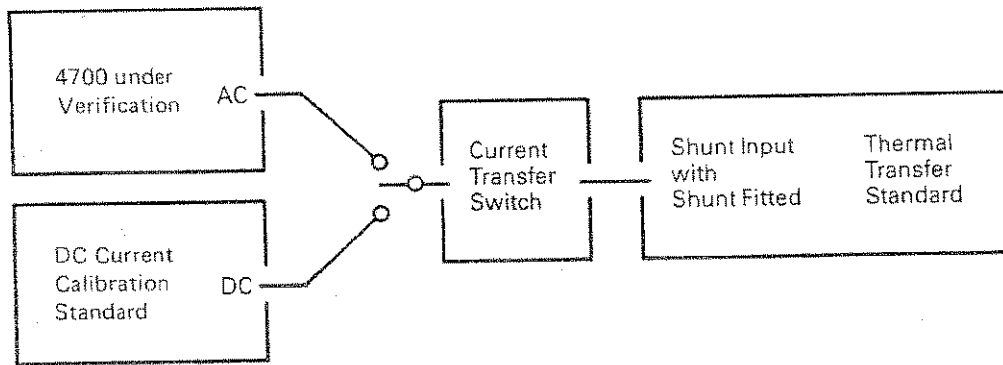

- a. With 4700 OUTPUT OFF, set the Function to AC and then I, OUTPUT Range to 10m, OUTPUT Display to the required current at a Frequency of 300Hz.
- b. Configure the Thermal Transfer for 10mA Current measurement and connect the appropriate shunt.
- c. With the DC Current Standard OUTPUT OFF, ensure that it is set to the required current, and connect its output terminals across the shunt.
- d. Set the DC Current Standard OUTPUT ON, and null the Thermal Transfer to its DC output current. Set its OUTPUT OFF and disconnect from the shunt. Record its output value as '4700 Required OUTPUT Current'.
- e. With OUTPUT OFF, connect the 4700 I+ and I- terminals across the Shunt.
- f. Set the 4700 AC Current OUTPUT ON and adjust its keys to null the Thermal Transfer. Record its output current on Report Sheet RS3 Table 3(a) as '4700 OUTPUT Display Reading for Null'. Set 4700 OUTPUT OFF.
- g. Ensure that the 4700 CALIBRATION INTERVAL switch is set to 90dy. Press the 4700 Spec key and record the MODE Display reading in ppm as ' $\pm U_r$  ppm'. Press the Spec key again to cancel.
- h. Set 4700 Frequency to 5kHz; repeat (f) and (g), then disconnect the 4700 terminals from the shunt.
- j. Obtain the Datron Calibration Uncertainty from Section 6 for the 4700 output, and record as ' $\pm U_d$  ppm'.
- k. Sum the Verification setup uncertainties and record as ' $\pm U_s$  ppm'. (Refer to Appendix 5).
- l. Repeat (a) to (k), but for 4700 LF and HF outputs, and DC Current Standard outputs close to 100mA and 1A Full Range.
- m. If the Thermal Transfer has been adequately calibrated for 1mA transfers, repeat (a) to (k) for DC and AC outputs close to 1mA Full Range, recording the 4700 output currents on Report Sheet RS3 Table 3(b).

### For Total Tolerance Limit Calculations

See Appendix 4 page 7-31 Para 2.

- n. Calculate the Lower and Upper Total Tolerance Limits:  
Use Calculations A and C if the 4700 was last calibrated by Datron.  
Use Calculations B and C if the 4700 was last calibrated against the standards being used for verification.
- p. Each 4700 Full Range verifies if the AC Current outputs recorded in (f) are at or between the corresponding Total Tolerance Limits.



# DANGER HIGH VOLTAGE



**THIS INSTRUMENT IS CAPABLE  
OF DELIVERING  
A LETHAL ELECTRIC SHOCK!**

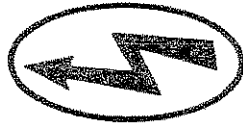

FRONT or REAR  
terminals carry the  
Full Output Voltage.

**THIS CAN KILL!**



Guard terminal is  
sensitive to over-  
voltage

**It can damage  
your instrument!**

Unless **you** are **sure** that  
it is **safe** to do so,  
**DO NOT TOUCH** the  
**I+ I- Hi** or **Lo** leads  
and **terminals**

# DANGER

# MODEL 4700 VERIFICATION REPORT SHEET, RS3

RS3 - For Users with Fixed DC Voltage Standards. (Output Values other than Full Range).

Serial Number \_\_\_\_\_ Date \_\_\_\_\_

Checked by \_\_\_\_\_ Company/Dept. \_\_\_\_\_

Note: - On receipt of the instrument it is recommended to check at the frequencies shown below.

## 1. AC VOLTAGE (Using Fixed DC Voltage Standard via Thermal Transfer)

### a. 1V to 1000V Ranges.

4700 OUTPUT RANGE/ FREQUENCY	4700 Required OUTPUT Voltage	4700 Spec Mode Readout ( $\pm U_r$ ppm)	Datron Cal. Std. Uncertainty ( $\pm U_d$ ppm)	User's Cal. Std. Uncertainty ( $\pm U_s$ ppm)	Wideband Calculated Total Tolerance Limits		4700 OUTPUT Display Reading for Null
					-Lim	+Lim	
1V 1kHz							
1V 1MHz							
10V 1kHz							
10V 1MHz							
100V 1kHz							
100V 100kHz							
1000V 1kHz							
1000V 30kHz							

### b. Linearity (Performed on 10V Range)

1V 1kHz							
10V 1kHz							
19.00000V 1kHz							

## 2. AC MILLIVOLTS 1mV to 100mV Ranges

### a. LF 1kHz (using Verified 1V Full Range, Inductive Voltage Divider and AC DVM)

4700 OUTPUT RANGE	4700 Required OUTPUT Voltage	4700 Spec Mode Readout ( $\pm U_r$ ppm)	Datron Cal. Std. Uncert'y ( $\pm U_d$ ppm)	User's Cal. Std. Uncert'y ( $\pm U_s$ ppm)	Wideband Calculated Total Tolerance Limits		4700 OUTPUT Display Setting
					-Lim	+Lim	
100mV							
10mV							
1mV							

### b. HF 1MHz (Using Verified 1V and 10V Full Range, 10% Range Correction and AC DVM)

100mV							
10mV							
1mV							

## 3. AC CURRENT

### a. 10mA to 1A Ranges. (Using Thermal Transfer, Current Shunts and DC Current Standard)

4700 OUTPUT RANGE FREQUENCY	Transfer Shunt Value	4700 Required OUTPUT Current	Wideband Relative Accuracy ( $\pm U_r$ ppm)	Datron Cal. Std. Uncert'y ( $\pm U_d$ ppm)	User's Cal. Std. Uncert'y ( $\pm U_s$ ppm)	Wideband Calculated Total Tolerance Limits		4700 OUTPUT Display Reading for Null
						Lower	Upper	
10mA 300Hz								
10mA 5kHz								
100mA 300Hz								
100mA 5kHz								
1A 300Hz								
1A 5kHz								

### b. 1mA Range. (If Thermal Transfer is calibrated at this level)

1mA 300Hz								
1mA 5kHz								

## APPENDIX 2

# ALTERNATIVE MILLIVOLT VERIFICATION PROCEDURE

(Using verified 4700 1V Range, Wideband Inductive Voltage Divider (WIVD) and AC DVM).  
Record results on Report Sheet RS4, (Page 7-28)

Full Range Checks (1mV – 100mV), LF (1kHz)  
and HF (100kHz).

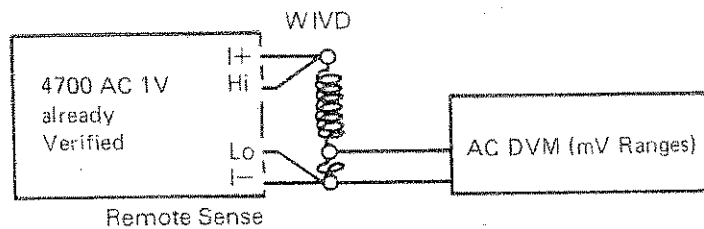

Standardization of DVM Millivolt Ranges

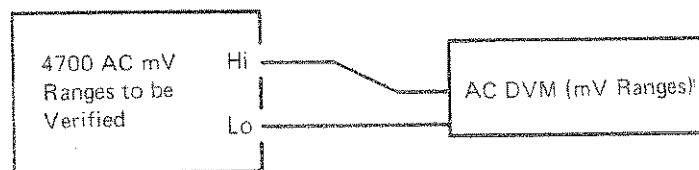

Verification of 4700 LF Millivolt Ranges

- a. With **OUTPUT OFF**, connect the 4700, WIVD and DVM for Standardization. Set the WIVD ratio to 1:1000, the AC DVM to measure 1mV.
- b. Set 4700 to 1V Range, 1kHz, and adjust for corrected 1.000000V output.
- c. Set 4700 **OUTPUT ON** and note the DVM reading as **V1**.
- d. Set 4700 **OUTPUT OFF**, and reconnect the test circuit for Verification.
- e. Set the 4700 **OUTPUT RANGE** to 1mV and adjust the **OUTPUT Display** to 1.0000mV.
- f. Set 4700 **OUTPUT ON** and adjust the **OUTPUT** keys for a DVM reading of **V1**.
- g. Record the 4700 **OUTPUT Display** setting in the last column of Report Sheet RS4.
- h. Repeat (a) to (g), but setting the 4700 frequency to 100kHz.
- j. Set the WIVD ratio and DVM as required to verify the 10mV and 100mV Full Range outputs; still using the corrected 1V Full Range output in (b). Record the results on Report Sheet RS4.
- k. Sum the Verification setup uncertainties and record in the **Us** column as voltage deviations (Refer to Appendix 5).

### Total Tolerance Limit Calculations

Refer to Appendix 4 page 7-31. Para 1.

- l. Calculate the Lower and Upper Total Tolerance Limits:  
Use Calculation A if the 4700 was last calibrated by Datron.  
Use Calculation B if the 4700 was last calibrated against the standards being used for verification.
- m. Each 4700 mV Full Range verifies if the 4700 **OUTPUT Display** readings recorded in (g) are at or between the corresponding Total Tolerance Limits.



# MILLIVOLTS (LF & HF) VERIFICATION REPORT SHEET. RS4

RS4 - For Users with Adjustable DC Voltage Standards.  
 (Using Verified 1V Full Range, Wideband Inductive Voltage Divider and AC DVM)

Serial Number \_\_\_\_\_ Date \_\_\_\_\_

Checked by \_\_\_\_\_ Company/Dept. \_\_\_\_\_

Note: - On receipt of the instrument it is recommended to check at the frequencies shown below.

## Full Range Outputs 1mV to 100mV Ranges

4700 OUTPUT RANGE FREQUENCY	4700 Nominal OUTPUT Voltage	Wideband Relative Accuracy Tolerance Limits		Datron Cat. Std. Uncert'y ±Ud(Abs)	User's Cat. Std. Uncert'y ±Us (Abs)	Wideband Calculated Total Tolerance Limits		4700 OUTPUT Display Setting
		Lower (Lr)	Upper (Ur)			Lower	Upper	
1mV 1kHz	1.0000mV	.9897	1.0103	0.0103mV				
1mV 100kHz	1.0000mV	.9893	1.0107	0.0115mV				
10mV 1kHz	10.0000mV	9.9872	10.0128	0.0125mV				
10mV 100kHz	10.0000mV	9.9228	10.0172	0.0166mV				
100mV 1kHz	100.0000mV	99.9620	100.0380	0.0350mV				
100mV 100kHz	100.0000mV	99.9180	100.0820	0.0670mV				

## APPENDIX 3

# ALTERNATIVE AC CURRENT VERIFICATION PROCEDURE USING CALIBRATED STANDARD AC SHUNTS

(Using verified 4700 1V Range,  
Calibrated Standard AC Shunts  
and AC DVM).

Record results on Report Sheet RS5  
(Page 7-28).

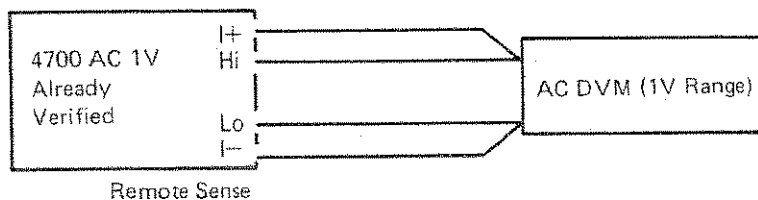

Standardization of DVM 1V Range

Full Range Checks ( $100\mu\text{A} - 1\text{A}$ )

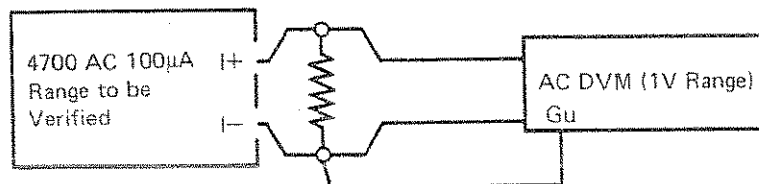

Verification of 4700 Current Ranges

N.B. The effects of shunt loading by the DVM must be accounted for when calculating the results. (Typical DVM input impedance: 1Mohm in parallel with 150pF.)

- a. With **OUTPUT OFF**, connect the 4700 and DVM for Standardization. Select 1V Range on the AC DVM.
- b. Set 4700 to 1V Range, 300Hz; and adjust for corrected 1.000000V output.
- c. Set 4700 **OUTPUT ON** and note the DVM reading as  $V_1$ .
- d. Set 4700 **OUTPUT OFF**, and set the 4700 **OUTPUT** range to  $100\mu\text{A}$ ; adjust the **OUTPUT Display** to  $100.0000\mu\text{A}$ .
- e. Reconnect the test circuit for Verification, using the appropriate Calibrated Standard Shunt.
- f. Set 4700 **OUTPUT ON** and note the DVM reading as  $V_2$  (see N.B. above).
- g. Calculate  $V_3$  as follows:  
$$V_3 = 1.000000\text{V} + (V_2 - V_1).$$
Record  $V_3$  as 'Measured Shunt Voltage' on Report Sheet RS5.

- h. Divide  $V_3$  by the shunt resistance to convert to current. Record as 'Calculated Current' on Report Sheet RS5.
- j. Repeat (a) to (h), but for all 4700 300Hz Current outputs on Report Sheet RS5, using appropriate shunts.
- k. Repeat (a) to (h) for all 4700 5kHz Current outputs on Report Sheet RS5.
- l. Sum the Verification setup uncertainties and record in the  $U_s$  column as current deviations (Refer to Appendix 5).

For Total Tolerance Limit Calculations  
Refer to Appendix 4 page 7-31 Para 1.

- m. Calculate the Lower and Upper Total Tolerance Limits:  
Use Calculation A if the 4700 was last calibrated by Datron.  
Use Calculation B if the 4700 was last calibrated against the standards being used for verification.
- n. Each 4700 Current Full Range output verifies if the Current outputs recorded in (h) are at or between the corresponding Total Tolerance Limits.

# AC CURRENT VERIFICATION REPORT SHEET. RS5

RS5 - For Users with Adjustable DC Voltage Standards.  
 (Using verified 1V Full Range, Calibrated Standard AC Shunts and AC DVM)

Serial Number \_\_\_\_\_ Date \_\_\_\_\_

Checked by \_\_\_\_\_ Company/Dept. \_\_\_\_\_

Note: - On receipt of the instrument it is recommended to check at the frequencies shown below.

## Full Range Outputs 100sA to 1A Ranges

4700 OUTPUT RANGE FREQUENCY	External Shunt Value	Wideband Relative Accuracy Tolerance Limits		Datron Cal. Std. Uncert'y $\pm U_d$ (Abs)	User's Cal. Std. Uncert'y $\pm U_s$ (Abs)	Wideband Calculated Total Tolerance Limits		Measured Shunt Voltage	Calculated Current
		Lower (Lr)	Upper (Ur)			Lower	Upper		
100 $\mu$ A 300Hz		99.9440	100.0560	0.0400 $\mu$ A					
100 $\mu$ A 5kHz		99.9250	100.0750	0.0900 $\mu$ A					
1mA 300Hz		.999620	1.000380	.000255mA					
1mA 5kHz		.999490	1.000510	.000255mA					
10mA 300Hz		9.99620	10.00380	0.00255mA					
10mA 5kHz		9.99490	10.00510	0.00255mA					
100mA 300Hz		99.9620	100.0380	0.0255mA					
100mA 5kHz		99.9490	100.0510	0.0255mA					
1A 300Hz		.999440	1.000560	0.000290A					
1A 5kHz		.999250	1.000750	0.000440A					

## APPENDIX 4

# TOTAL TOLERANCE LIMIT CALCULATIONS

This appendix lists the calculations necessary to determine the Total Tolerance Limits for each of the verification procedures.

Reference to the appropriate calculation is given in each procedure.

1. AC Volts, Millivolts and Current Ranges when an **Adjustable** DC Voltage or Current Source is used as the Standard.

The abbreviations used for these calculations are:

$L_r$  = Lower Wideband Relative-Accuracy Tolerance Limit;

$U_r$  = Upper Wideband Relative-Accuracy Tolerance Limit;

$U_d = U_d$  (Abs) = Datron's Calibration Uncertainty expressed as a voltage or current;

$U_s = U_s$  (Abs) = User's Calibration Standard Uncertainty expressed as a voltage or current.

### A. On Receipt from Datron:

For each 4700 OUTPUT Value/Frequency selection calculate the Total Tolerance Limits as follows:

$$\begin{aligned} \text{Lower Total Limit} &= L_r - U_d - U_s \\ \text{Upper Total Limit} &= U_r + U_d + U_s \end{aligned}$$

Enter the results as Lower and Upper Total Limits respectively.

### B. Following User Calibration:

For each 4700 OUTPUT Value/Frequency selection calculate the Total Tolerance Limits as follows:

$$\begin{aligned} \text{Lower Total Limit} &= L_r - U_s \\ \text{Upper Total Limit} &= U_r + U_s \end{aligned}$$

Enter the results as Lower and Upper Total Limits respectively.

2. AC Volts, Millivolts and Current Ranges when a **Fixed** DC voltage or Current Source is used as the Standard.

The abbreviations used for these calculations are:

$U_r = U_r$  ppm = 4700 Spec. Mode Readout;

$U_d = U_d$  ppm = Datron's Calibration Uncertainty expressed in ppm of the reading;

$U_s = U_s$  ppm = User's Calibration Standard Uncertainty expressed in ppm of the reading;

$U_t$  = Cumulative Uncertainty as calculated, expressed in ppm of the reading.

$V$  = Required 4700 OUTPUT Value of voltage or current.

### A. On Receipt from Datron

For each 4700 OUTPUT Value/Frequency selection calculate the Cumulative Uncertainty ( $U_t$ ) from:

$$U_t = U_r + U_s \text{ (ppm).}$$

Calculate the Lower and Upper Total Tolerance Limits as in (C) below.

### B. Following Calibration against the same Standard

Calculate the Cumulative Uncertainty ( $U_t$ ) from:

(For CALIBRATION INTERVALS 90dy or 1yr)

$$U_t = U_r + U_s - U_d \text{ (ppm),}$$

(For CALIBRATION INTERVAL 24hr)

$$U_t = U_r + U_s \text{ (ppm).}$$

Calculate the Lower and Upper Total Tolerance Limits as in (C) below.

### C. Obtain the Cumulative Uncertainty from (A) or (B) and calculate the limits:

$$\text{Lower Limit} = V - \frac{(V + U_t)}{10^6};$$

$$\text{Upper Limit} = V + \frac{(V + U_t)}{10^6}.$$



# DANGER HIGH VOLTAGE



**THIS INSTRUMENT IS CAPABLE  
OF DELIVERING  
A LETHAL ELECTRIC SHOCK!**



FRONT or REAR  
terminals carry the  
Full Output Voltage.

**THIS CAN KILL!**



Guard terminal is  
sensitive to over-  
voltage

**It can damage  
your instrument!**

Unless **you** are **sure** that  
it is **safe** to do so,  
**DO NOT TOUCH** the  
**I+ I- Hi** or **Lo** leads  
and **terminals**

# DANGER

## APPENDIX 5

# UNCERTAINTY AND TRACEABILITY

### Cumulative Tolerances

If an instrument was correctly calibrated against the factory standard at its uncertainty limit, and then verified against a user's standard, also at its limit; there are two extremes to the range of traceable results which could be obtained. If, for example, both standard's traceable errors were equal and in the same sense, the instrument would appear to verify as absolutely accurate. But if the errors were in opposite sense, it could appear to be inaccurate by the sum of the two limits of uncertainty.

In the following numerical example, a 4700 is verified in the factory at 10V, 1kHz on the 10V Range, and with 0ppm error against a 20ppm-high standard.



It remains correctly calibrated, and could be delivered to one of two users: one user's standard is 20ppm higher than the National Standard, and the other's is 20ppm lower.

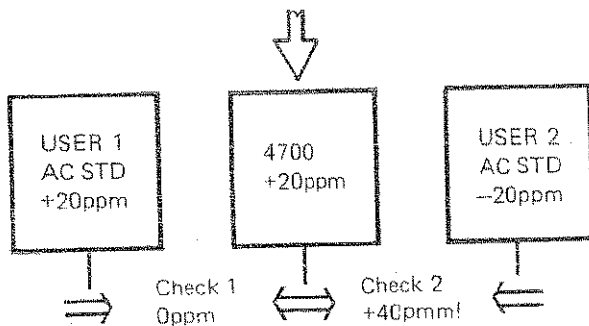

Despite the instrument sustaining its original accuracy of +20ppm and the standards all being within 20ppm of National Standards; the first user would verify the 4700 has having 0ppm error, but the second would obtain an error of +40ppm.

The increased uncertainty is unavoidable unless the same standard is used for each verification. This is clearly not a practical proposition following delivery. But after the first autocalibration against the user's standard, Datron's calibration uncertainty no longer applies.

### Verification Uncertainties

Each element in the calibration traceability chart (on the next page) contributes its uncertainty to influence the overall verification tolerance limits. All uncertainties must be accounted for when calculating the total tolerances.

In addition, if two separate systems are used, one for calibration and the other for verification, then the cumulative total tolerance is the sum of those established for each system (as described earlier).

Thus on receipt of the 4700, Datron's uncertainties must be included in the total tolerance limits; but when verifying against the same Standards setup used to calibrate the instrument they are excluded.

Two formulae for calculating the total tolerance limits are given for each procedure, covering the two types of verification occasions mentioned.

### Total Tolerance Limit Calculations

The 4700 is verified by comparing its output with the Total Tolerance Limits. These are calculated by summing the appropriate uncertainties from the traceability chart, and expressing the result in upper and lower absolute deviations from the chosen verification value. The 4700 checks out if its measured output is between the limits.

Where possible, the 4700 specification and Datron calibration uncertainties are given in a form suitable for calculation (see Report Sheet RS2). Where this is not possible they can be assembled from the specifications in Section 6, and in some cases can be more easily obtained using Spec Mode (Report Sheet RS3 has columns for this purpose).

User's uncertainties need to be assembled and included, expressed in the form appropriate to the calculations.

Whereas Datron's uncertainties are normally included in the calculations only once (on receipt), user's uncertainties must always be included. So it is sensible to provide a permanent record, e.g. on Report Sheets.

Once the relevant uncertainties have been entered on the Report Sheet, the Total Tolerance Limits can be calculated. The correct calculations are identified in the individual procedures.

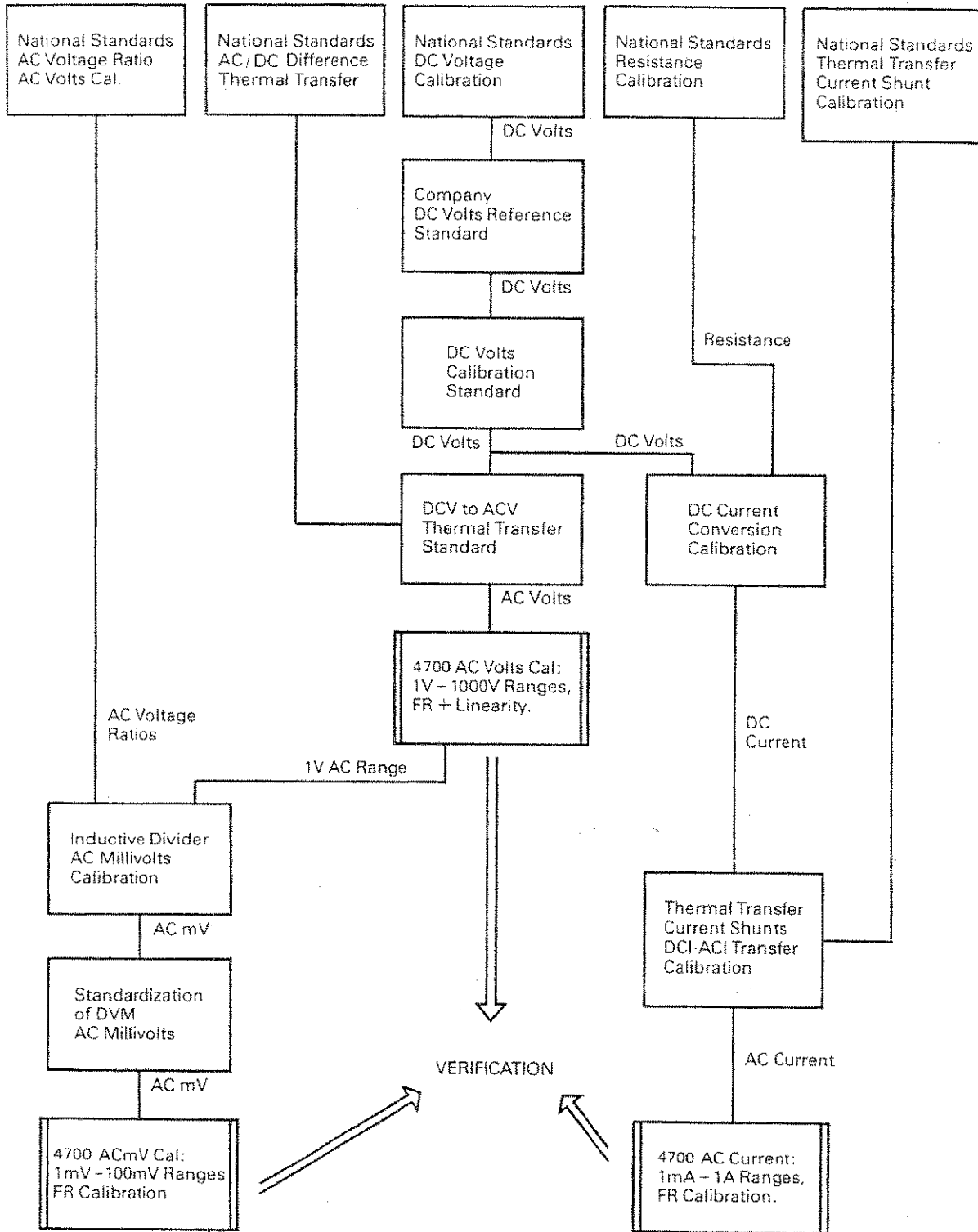

Recommended AC Verification Procedures Calibration Traceability Chart

## APPENDIX 6

# GENERAL PROCEDURAL INFORMATION

### Thermal Transfer

The Thermal Transfer Standard is connected between the DC Voltage Source and the 4700.

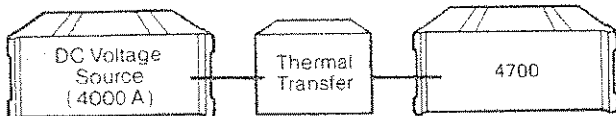

A 4-wire sense connection will reduce inaccuracies due to differences in the output impedances of the DC voltage source and the 4700.

Four points are important:

1. Start with OUTPUT OFF  
The 4700 should be connected to the Thermal Transfer Standard only when the 4700 OUTPUT OFF LED is lit. (With Output OFF, the I+, I-, Hi and Lo terminals are at high impedance).
2. Sensitivity  
Always set the Thermal Transfer Standard to its lowest sensitivity before connecting up. Increase sensitivity when necessary to obtain the required input level.

#### WARNING

During Performance checks and calibration the full range voltage is present at the Thermal Transfer Standard input terminals. On 1000V checks this voltage is potentially lethal, so EXTREME CAUTION must be observed when making adjustments to the Thermal Transfer Standard sensitivity.

#### CAUTION

The Thermal Transfer Standard used must be able to withstand peak voltages up to 1600V between its input terminals. Such voltages may be present during the time that the 4700 is ramping from zero to 1100V Full Scale after setting OUTPUT ON.

3. Local/Remote Sense  
Remote Sense is available as follows:

1V 10V 100V 1000V — Local/Remote Sense  
1mV 10mV 100mV — Local Sense only  
All Current Ranges — not applicable

Local = Remote Sense LED OFF - 2-Wire Sense  
Remote = Remote Sense LED ON - 4-Wire Sense

OUTPUT must be OFF to change Sense connection (except that Remote changes automatically to Local when switching to Millivolt Ranges).

#### 4. Up-ranging - OUTPUT OFF Default

The 4700 cannot enter High-Voltage State (>75V) with OUTPUT ON. Consequently, when ranging-up, the operating system allows the up-ranging to occur, but defaults to OUTPUT OFF for two specific cases:

- a. When up-ranging to the 1000V Range,
- b. When up-ranging to the 100V Range to a voltage of 75V or more.

In H-V state an audible warning is provided.

Otherwise, OUTPUT remains ON when changing OUTPUT RANGE.

### Other Useful Features

Although not essential to normal verification, the following additional facilities can sometimes simplify procedures:

FREQUENCY Store: Refer to Section 4 page 4-10,

'Spec' Mode: Refer to Section 4 page 4-10,

'Error' Mode: Refer to Section 4 page 4-12.



# General Procedural Information

## 4700 Specification Formats

The specifications can be found in two forms:

### a. Tabular layout as in Section 6

In Section 6, the stability and relative accuracy specifications alone describe the true performance of the instrument, in a form which can be made traceable to National Standards, merely by adding in the uncertainty of the reference standard used for checking. Datron's calibration uncertainty is shown in a separate column. This must be added, to obtain true traceable accuracy for all instruments which were last calibrated by Datron. For instruments calibrated by other agencies, their calibration uncertainty must be added instead.

### b. Specifications stored within the instrument's non-volatile memory.

(see Section 4 page 4-10 to 4-12).

The instrument's non-volatile memory figures can be accessed using 'Spec' Mode. These are compiled specifically for users without verification facilities, so that they can determine the tolerance limits of the 4700 output, without reference to Section 6. The 90 day and 1 year accuracy readout includes Datron's calibration uncertainty, giving traceable accuracies for instruments which were last calibrated by Datron.

### 24hr CALIBRATION INTERVAL

24 Hours Stability figure only.

### 90dy CALIBRATION INTERVAL

90 Days Wideband Relative Accuracy figure + Datron's Calibration Uncertainty.

### 1yr CALIBRATION INTERVAL

1 Year Wideband Relative Accuracy figure + Datron's Calibration Uncertainty.

Spec mode provides 90 day and 1 year accuracy figures which are traceable through Datron standards to National Standards, for users who have no calibration or verification facilities.

## Verification Conditions

The 24-hour stability specifications are relative to user's reference standards. In all cases validity depends on using the same standard as reference, under the same conditions, including temperature. Also, verification is valid only within 24 hours of calibration or within 24 hours of a previous

verification. In the latter case, the specifications are relative to the figures obtained at the earlier verification.

On receipt, the 90-day and 1-year tolerances can be calculated by adding both the user's reference standard uncertainty and Datron's calibration uncertainty to the Relative Accuracy figure (Section 6).

Following User Calibration or a Previous Verification, add only the user's uncertainty to the Relative Accuracy figure.

Where ambient temperatures are outside the Specified range, temperature coefficient correction should be taken into account.

## Report Sheets

Please use the printed report sheets as masters to generate duplicate copies, then record the instrument's performance on the duplicates (both on receipt from Datron and for future periodic checks).

The 'Adjustable DC Voltage Standard' report sheet (page 7-19) lists the appropriate wideband relative accuracy limits, and Datron's calibration uncertainty at the verification points. Blank columns are provided for the user's calibration uncertainty, the cumulative tolerance limits, and the DC Voltage Standard's adjusted reading (for comparison with the tolerance).

The 'Fixed DC Voltage Standard' report sheet (Appendix 1, page 7-25) should be used if the DC Reference Standard cannot be used at the values required for the checks detailed in the tables. In this case the 4700 'Spec Mode' can be accessed to generate its tolerance limits, but these will need to be processed to calculate the true cumulative tolerances.

The appropriate limit calculations are detailed in Appendix 4.

## APPENDIX 7

# HARMONIC DISTORTION MEASUREMENT

The measurement of Total Harmonic Distortion (THD) is not detailed as part of the verification procedure. However, some users may wish to check this feature from time to time, so one or two points need to be clarified.

The very low noise content of the 4700 output is included in its accuracy specifications, but not in its TOTAL HARMONIC DISTORTION specifications on pages 6-5 and 6-11. The latter relate to true harmonic distortion only.

If the 4700 distortion specification is to be verified, the measurement equipment must be selected with care. Some distortion meters merely suppress the fundamental and measure the remainder over a specific bandwidth. The readings obtained include wideband noise integrated over the full bandwidth, introducing measurement errors which increase the apparent harmonic distortion (particularly at low fundamental levels, where the harmonic envelope rapidly descends into the noise floor).

Measurement of true harmonic distortion only, in any signal, can be a laborious process. To measure the value of each single frequency harmonic, (as would be required to verify the 4700 THD specification), any wideband noise must be filtered out. Very selective bandpass notch filtering is required; this is usually achieved by phase-locking the measurement circuitry to the signal, as performed by a selective signal level meter.

A modern automatic spectrum analyzer is more satisfactory. The harmonic amplitudes can be displayed on a screen against a grid, the noise levels can also be seen, or a cursor can be used to set a bandpass notch filter to the harmonic frequency required, to give a direct digital readout. THD measurement is simplified and speeded up by this method.

It is therefore recommended that either a spectrum analyzer or selective level meter be employed. Suitable instruments are:

Hewlett-Packard HP 3585 Spectrum Analyzer, or  
HP3586 Selective Level Meter.



**DANGER**  
**HIGH VOLTAGE**



**THIS INSTRUMENT IS CAPABLE  
OF DELIVERING  
A LETHAL ELECTRIC SHOCK!**



FRONT or REAR  
terminals carry the  
Full Output Voltage.

**THIS CAN KILL!**



Guard terminal is  
sensitive to over-  
voltage

**It can damage  
your instrument!**

Unless **you** are **sure** that  
it is **safe** to do so,  
**DO NOT TOUCH** the  
**I+ I- Hi or Lo leads**  
and **terminals**

**DANGER**

# SECTION 8 ROUTINE AUTOCALIBRATION

Users requiring to verify the specification without adjustment to the instrument's calibration status refer to Section 7. For full information on calibration of the 4700 refer to the Calibration and Servicing Handbook, Section 1.

## The 4700 Autocal Feature

Using the standard 'Autocal' feature, the 4700 is calibrated entirely from the front panel (or remotely via the IEEE 488 Interface). Because it is not necessary to remove the covers, thermal disturbance is avoided and the 4700 can be put back into service immediately after calibration.

Users wishing to maintain the highest specification (24 Hours) can recalibrate daily, on a regular basis, if desired. The procedures contained in this Section provide the essential information for setting up such routines. It is not necessary to update all ranges, as it is possible to calibrate one output range.

During the Autocal process, the microprocessor adjusts correction factors which are already stored in non-volatile memories. After adjustment, the updated factors are continuously applied to correct the 4700 output amplitude.

Special keys are used in the Autocal mode. They are illustrated below:

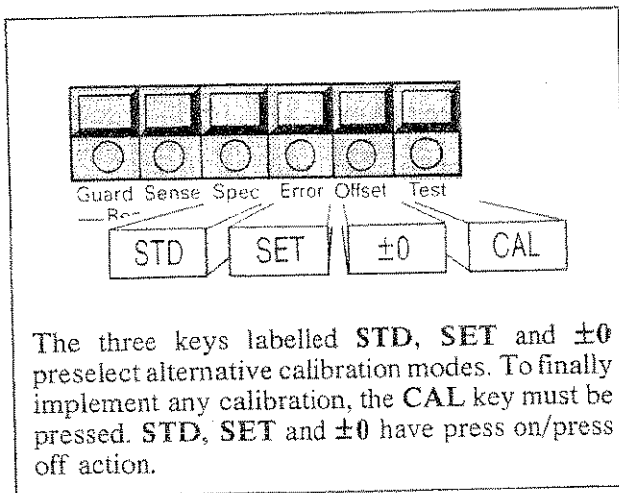

These keys are activated by a simple procedure. On the rear panel there are two switches: the IEEE address switch, and a security keyswitch labelled **RUN/CAL ENABLE**. By setting the address switch to 31 (ADD 11111) for Front Panel calibration and the keyswitch to **CAL ENABLE**, four of the front panel **MODE** keys are reassigned to calibration functions, permitting access to the correction memories.

The activation procedure is illustrated below:

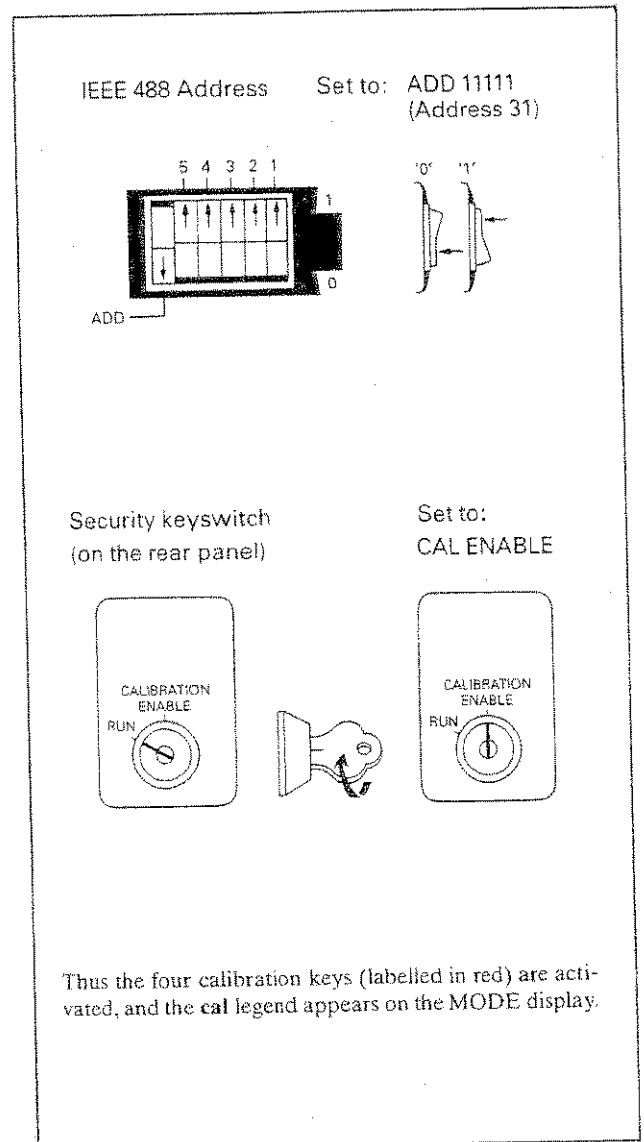

Once the keys are activated, up to four modes of calibrating the 4700 become available. The meanings of the modes differ slightly for DC and AC Calibration.

The meanings of the names, and the detailed procedures for using the modes, are described overleaf.

## DC Calibration

**STD key** STD calibration is carried out on the 1V or 10V range, and differs from the "SET" procedure only in the use of the STD key instead of the SET key.

It changes the DC gain of all voltage and current ranges in the same ratio, and thus performs the same function as trimming the internal Master Reference voltage. The facility can be used to avoid a full recalibration of the 4700 when Laboratory References have been re-standardized (or for instance when a 4700 has been moved from one country to another). In DC mode it does not affect AC or Ohms.

**SET key** The SET key allows calibration to any value in the selected Range (e.g. at a standard cell voltage):

Before selecting SET, the  $\uparrow/\downarrow$  keys are operated to place the Calibration Standard value on the OUTPUT display and set the 4700 output level. Pressing SET then informs the 4700 that calibration is to be carried out at this value. The instrument acknowledges by duplicating the value on the MODE display.

Next, the  $\uparrow/\downarrow$  keys are manipulated to null the 4700 output against the Calibration Standard (the OUTPUT display changes during this adjustment).

Pressing the CAL key executes the calibration. The 4700 memorizes the difference between the two display values, and exits from SET mode. This is shown by transfer of the Standard value from the MODE display to the OUTPUT display. The instrument uses the difference to modify stored constants, which in "RUN" mode correct both positive and negative outputs on the calibrated range only.

If the Calibration Standard value is below 2% of Full Range, the 4700 assumes a request for "Offset" correction; but if at 2% or above, "Gain" correction is assumed.

**$\pm 0$  key** The  $\pm 0$  key is used to align the ON+ and ON- zeroes of all voltage and current ranges by a 2-part calibration on the 10V range. The  $\pm 0$  Alignment Routine on Page 8-6 is necessary only when the ON+ and ON- zeroes on the 10V range do **not** coincide at the same null.

**CAL Key** The CAL key executes the preselected Autocal facility, as described in "SET" above. Alternatively, it can be used without first pressing SET,  $\pm 0$  or STD to calibrate Voltage or Current ranges, but only at Zero or Full Range values:

Before selecting CAL, the Zero or Full Range key is pressed to set the 4700 output level.

Next the  $\uparrow/\downarrow$  keys are manipulated to null the 4700 output against the Calibration Standard (the OUTPUT display changes during this adjustment).

Pressing CAL commands the 4700 to calibrate. The instrument decides on "Zero Offset" or "Full Range Gain" from the OUTPUT display value (defined by the same limits as for "SET"), and executes the calibration. The difference between the OUTPUT display value and the value chosen by the 4700 is used to modify the stored constants mentioned in "SET" above.

## Autocal Availability

As the Autocal keys perform specific DC tasks, they are available only as defined by Table 8.1. The message "Error 3" appears on the **MODE** display for any attempt to select an inappropriate mode.

AUTOCAL DC Mode		DC Voltage (DC)	DC Current (I)	Resistance ( $\Omega$ )	
				Local Sense (2-wire)	Remote Sense (4-wire)
SET and CAL	Zero offset for range at User's selected value	All Ranges	All Ranges		
	Gain for range at User's standard value	100mV-1000V Ranges only			
$\pm 0$ and CAL	Alignment of internal ON+ and ON- zeros	10V Range only			
STD and CAL	Internal Reference gain at User's Standard value	1V and 10V Range only			
CAL Only	Zero offset for range	All Ranges	All Ranges	10 $\Omega$ -1M $\Omega$ Ranges only	All Ranges
	Gain for range at Full Range Value	10mV-1000V Ranges only			

Table 8.1 Autocal availability for DC Calibration

## Zero Calibration

It is common practice to accept a small offset in the output of a voltage calibration standard, providing that the same offset is present at all output values, including zero.

The output of the 4700 is fully floating, so its output may be referred to any common mode voltage within the range specified on page 6.1. In particular, its zero may be aligned to absolute zero in Local Sense by calibration to a null across its Hi and Lo (Sense) terminals. But if it is then gain-calibrated against an offset standard without re-zeroing to that standard's offset zero, normal mode gain errors will result.

It is therefore essential that each voltage and current range zero is first calibrated to a standard's zero before using that standard to calibrate the range gain.

If the 4700 zero output is to be regarded as absolute Laboratory Reference Zero, then **AFTER** range gain calibration its range zero output may be recalibrated to a null across the Hi and Lo (Sense) terminals.

## Equipment Required for DC Calibration

DC Voltage — A Standard DC Voltage source of suitable accuracy:

Example:

Series bank of 10 standard cells and Datron 4904 Standard Cell buffer.

— A Precision Divider:

Example: Datron 4902 High Voltage Divider and Datron 4903 DC Switching Unit

— A battery-operated null detector with variable sensitivity, able to withstand 1200V across its input terminals:

Example: Keithley Instruments Model 155

DC Current — A DC Voltage source, calibrated to suitable accuracy at approximately 1V and 100mV:

Example: The standard voltage source used for DC Voltage, with the Datron 4903 DC Switching Unit.

— The battery-operated null detector used for DC Voltage.

— A set of calibrated current shunts of suitable accuracy.

**N.B.** To allow the same value to be set on the DC Voltage source for each range, the shunts may be of five decade values. Then the same Null Detector sensitivity can be used on each range.

**CAUTION** When choosing a set of current shunts ensure that their power dissipation ratings are sufficient to avoid permanent degradation from the self-heating effects of the current being checked. This applies particularly to the 1 Amp shunt.

— alternatively, a DMM of sufficient accuracy may be used to measure the voltage across the set of calibrated current shunts.

Example: Datron 1081 using "compute" mode.

Resistance — a set of standard resistors covering 10 $\Omega$  to 100M $\Omega$ . The 10 $\Omega$  to 10k $\Omega$  should be 4-wire type.

— an accurate resistance bridge, or other ratiometric device for measuring resistance to the required accuracy.

— a Datron 1081 used as a transfer-measurement device.

## Interconnections

Interconnection instructions in this section are necessarily simple and basic, and are mainly intended to show connections to the 4700. It is recognized that they may need to be adapted to meet an individual user's requirements. It is assumed that users will possess knowledge of the operation and use of standards equipment such as that mentioned above.

## DC Calibration Sequence

The sequence of operations for DC calibration of a 4700 is given below:

Preparation  
DC Voltage  
DC Current  
Resistance  
Return to Use

If only a partial recalibration is to be done, step 1 of the DC Voltage sequence should be carried out immediately after the preparation.

**WARNING** During Performance checks and calibration a common mode voltage equal to the full range voltage may be present at the Null Detector input terminals. On  $\pm 1000V$  checks this voltage is potentially lethal, so **EXTREME CAUTION** must be observed when making adjustments to the null detector sensitivity.

**CAUTION** The Null Detector used must be able to withstand voltages up to 1200V between its input terminals. Such voltages will be present during the time that the 4700 is ramping from zero to 1000V Full Range after setting OUTPUT ON. Inadvertent disconnection of the Precision Divider terminals can transfer full output across the Null detector.

**Preparation:** Before any calibration from the front panel is carried out, prepare the 4700 as follows:

1. Turn on the instrument to be checked and allow minimum of 4 hours to warm-up in the specified environment.

2. IEEE 488 Address switch:  
Set to **ADD 11111** as shown (Address 31).

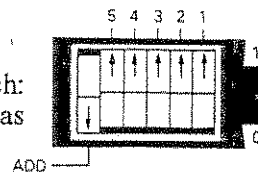

3. **CALIBRATION ENABLE** key switch:  
Insert calibration Key and turn to **ENABLE**.

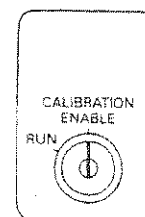

These actions activate the four calibration modes (labelled in red) and present the cal legend on the MODE display.

4. Ensure that OUTPUT OFF LED is lit.

**Return to Use:** When any calibration is completed, return the 4700 to use as follows:

1. Ensure that OUTPUT OFF LED is lit.

2. **CALIBRATION ENABLE** key switch:  
Turn to **RUN** and withdraw calibration key.

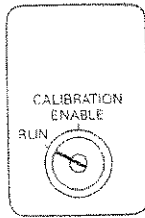

3. **IEEE 488 Address switch:**  
Restore to **correct address** if the 4700 is to be used in an IEEE 488 system.

## 4700 DC Voltage Calibration

### 1. Initial Setup

**CAUTION:** First read the Notes on the use of the Null Detector in Section 7.

Carry out the Preparation as detailed on Page 8-4.

Select **DC** and connect the DC Voltage Calibration Source and Null Detector to the 4700 terminals as shown in Fig. 8.1(a).

Use short leads, ensure that the Calibration Source voltage is set to zero and that the inter-connecting circuit has thermally stabilized.

### 2. Calibrate as follows:

#### a) Full Calibration

Calibrate the DC Voltage ranges in the step sequence of Table 8.2, using the Calibration Routine at each step (except steps 2 and 3). For steps 10 - 13, reconnect as Fig. 8.1(b).

#### b) Partial Calibration

Carry out Step 1 of Table 8.2.

Proceed with the desired steps of Table 8.2, using the Calibration Routine at each step (except steps 2 and 3). For steps 10 - 13, reconnect as Fig. 8.1(b).

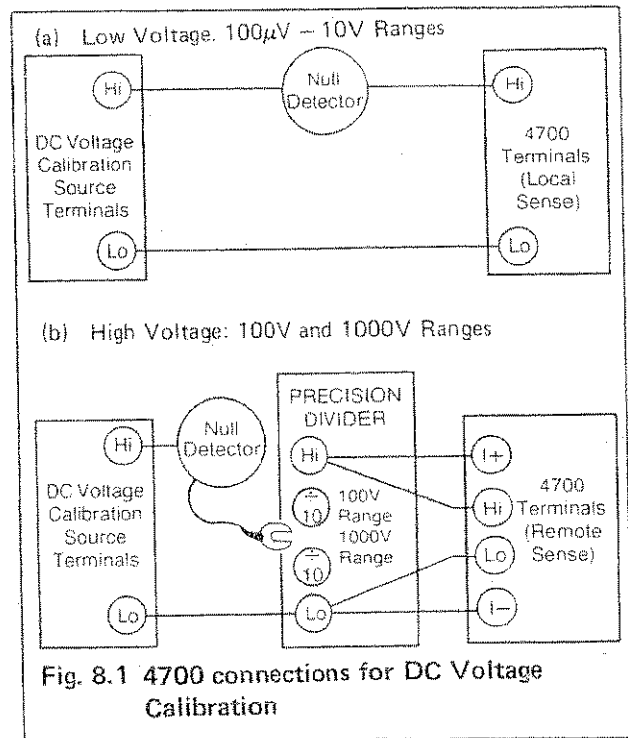

Fig. 8.1 4700 connections for DC Voltage Calibration

### c) Re-standardizing using "STD"

To re-standardize all DC Voltage and Current ranges in the same ratio, carry out steps 1, 2, 3, then either 6 and 7, or 8 and 9. In operation (g) of the Calibration Routine, substitute "STD" for "SET". (Refer to earlier description of "STD").

**3. Calibration Routine:** Calibration of DC Voltage to a Standard voltage calibration source.

**NOTES:** A For calibration at any value, this routine may be used as printed.

B For calibration at zero or positive nominal Full Range only, operation (g) may be omitted.

C In Table 8.2(a), use interconnections as Fig. 8.1(a) (Low Voltage), obtaining the correct calibration voltage from the source.

In Table 8.2(b), use interconnections as Fig. 8.1(b) (High Voltage) selecting  $\pm 10$  at steps 10 and 11,  $\pm 100$  at steps 12 and 13.

**CAUTION:** Below 2% of Range, the 4700 corrects for an assumed offset error, at 2% of Range and above the correction is for an assumed gain error.



### 3. Calibration Routine (contd.)

- a) Null Detector Set to **Low** sensitivity.
- b) 4700 Ensure **OUTPUT OFF**.
- c) DC Source Set to the required polarity and value.
- d) 4700 Select correct **FUNCTION** and **RANGE**.
- e) 4700 Use **Full Range, Zero** or **OUTPUT**  $\uparrow\downarrow$  keys to set the required polarity and value on **OUTPUT** display.

N.B. Operation (f) must be carried out before operation (g).

- f) 4700 Press the correct-polarity **ON** key.

Omit Operation (g) if calibrating at **zero** or **Full Range** value.

- g) 4700 Press **SET** key:  
**SET LED** lights green.  
**OUTPUT** display reading also appears on **MODE** display.

- h) Null Detector Increase sensitivity to give an off-null reading and use 4700 **OUTPUT**  $\uparrow\downarrow$  keys to back off to null. Repeat until null lies between two values of the **OUTPUT** display least-significant digit.

- j) Null Detector Set to **LOW** sensitivity.

- k) 4700 Press **CAL** key:  
**CAL LED** flashes once.  
**MODE** display value is transferred to **OUTPUT** display.  
**MODE** display is cleared.  
**SET LED** goes **OFF**.
- Not applicable if operation (g) omitted

The 4700 is now calibrated at this value.

**$\pm 0$  Alignment Routine:** Alignment of 10V Range positive and negative zeroes if necessary at step 3 of Table 8.2.

- a) Null Detector Set to **low** sensitivity.
- b) 4700 Ensure **OUTPUT OFF** on **DC 10V** Range.
- c) Calibration Source Ensure set to **zero** and thermally stable.

- d) 4700 Press **OUTPUT Zero** Key.  
Press **ON+** Key.  
Press  $\pm 0$  Key:  
 $\pm 0$  **LED** lights, **OUTPUT** display at **zero**.

- e) Null Detector Increase sensitivity to give an off-null reading and use 4700 **OUTPUT**  $\uparrow\downarrow$  keys to back off to null. Repeat until null lies between two values of the **OUTPUT** display least-significant digit.

- f) 4700 Press **CAL** key:  
**CAL LED** lights.  
No change to **OUTPUT** display.

- g) 4700 Press **ON-** key.

- h) Null Detector Obtain accurate null as in (e) above.

- j) 4700 Press **CAL** key:  
**CAL LED** goes **OFF**.  
 $\pm 0$  **LED** goes **OFF**.  
**OUTPUT** display falls to **zero**.

The 4700 positive and negative zeroes are now both aligned to the Calibration Source zero.

**Table 8.2 STEPS in DC VOLTAGE CALIBRATION**

(a) Low Voltage — connect as Fig. 8.1(a)

Step	Calibration Operation	4700 Range	Calibration Source Voltage	4700 Output Setting (Nominal value)[1]	AUTOCAL Key Used[2]
1	10V Range ON+ zero	10	0.000000V	(ON+) 0.000000V	—
2	10V Range ON- zero check only - do not calibrate	10	0.000000V	(ON-) 0.000000V	Check only 0.000000V
3	±0 Alignment	10	0.000000V	Refer to ±0 Alignment Routine	'±0'
4	100mV Range zero	100m	0.00000mV	0.00000mV	—
5	100mV Range gain	100m	+100.00000mV	(ON+) 100.00000mV	'SET' for non-nominal
6	1V Range zero	1	.0000000V	(ON+) .0000000V	—
7[3]	1V Range gain	1	+1.0000000V	(ON+) 1.0000000V	'SET' for non-nominal
8	10V Range zero	10	0.000000V	(ON+) 0.000000V	—
9[3]	10V Range gain	10	+10.000000V	(ON+) 10.000000V	'SET' for non-nominal

(b) High Voltage — connect as Fig. 8.1(b)

Step	Calibration Operation	4700 Range	Calibration Source Voltage	Precision Divider Select	4700 Output Setting (Nominal value)[1]	AUTOCAL Key Used[2]
10	100V Range zero	100	0.00000V	÷10	(ON+) 0.00000V	—
11	100V Range gain	100	+10.000000V	÷10	(ON+) 100.00000V	'SET' for non-nominal
12	1000V Range zero	1000	0.0000V	÷100	(ON+) 0.0000V	—
13	1000V Range gain <b>LETHAL VOLTAGE</b>	1000	+10.000000V	÷100	(ON+) 1000.0000V Enter High Voltage state using interlock procedure (User's Handbook Sect. 4)	'SET' for non-nominal

- NOTES** [1] It is expected that many users will wish to calibrate Range gains at values other than the nominals shown. In these cases set the Calibration Source voltage and 4700 OUTPUT display to in-house standard values near nominal.  
 [2] Except for Step 2, use CAL key as trigger (Refer to Calibration Routine).  
 [3] To trim the internal Master Reference voltage, substitute 'STD' for 'SET' for 1V or 10V Range (Refer to Calibration Routine and description of 'STD').

# 4700 DC Current Calibration

1. Ensure that the 4700 **OUTPUT OFF** LED is lit. Select DC and I and connect the DC Voltage calibration source, null detector and calibrated current shunt to the 4700 OUTPUT terminals as shown below. **Do not connect** null detector to shunt until the voltage across the shunt and the source voltage are close in value.

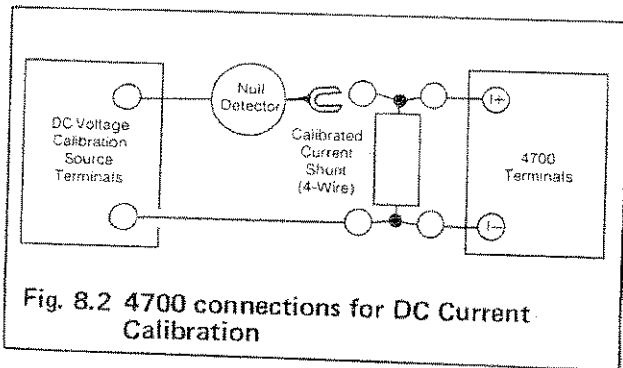

Preferred shunt values are as follows:

	Calibration Source Output Voltage for Full Range
100 $\mu$ A range - 10k $\Omega$ 1mW min	1V
1mA range - 1k $\Omega$ 10mW min	1V
10mA range - 100 $\Omega$ 100mW min	1V
100mA range - 10 $\Omega$ 1W min	1V
1A range - 0.1 $\Omega$ 1W min	100mV

Ensure that the calibration source voltage is set to zero and that the interconnecting circuit has thermally stabilized.

2. Calibrate the DC Current ranges in the step sequence of Table 8.3, using the Calibration Routine at each step.

3. **Calibration Routine:** Calibration of DC Current using a DC Voltage Calibration Source and a series of calibrated current shunts.

**NOTES:** A. For calibration at any value, the routine may be used as printed.

B. For calibration at zero or positive nominal Full Range only, operation (g) may be omitted.

**CAUTION:** Below 2% of Range, the 4700 corrects for an assumed offset error, at 2% of Range and above the correction is for an assumed gain error.

- a) Null Detector Set to **Low** sensitivity
- b) 4700 Ensure **OUTPUT OFF**
- c) DC Source Set to the required polarity and value
- d) 4700 Select correct **FUNCTION** and **RANGE**
- e) 4700 Use **Full Range, Zero** or **OUTPUT**  $\uparrow/\downarrow$  keys to set the required polarity and value on **OUTPUT** display.

**N.B.** Operation (f) must be carried out before operation (g)

- f) 4700 Press the correct polarity **ON** key

**CAUTION:** Pressing the wrong **ON** key will result in twice the **OUTPUT** being connected across the null detector.

Omit operation (g) if calibrating at Zero or Full Range value.

- g) 4700 Press **SET** key:  
**SET LED** lights green.  
**OUTPUT** display reading also appears on **MODE** display.

- h) Null Detector Increase sensitivity to give an off-null reading and use 4700 **OUTPUT**  $\uparrow/\downarrow$  keys to back off to null. Repeat until null lies between two values of the **OUTPUT** display least-significant digit.

- j) Null Detector Set to **LOW** sensitivity

- k) 4700 Press **CAL** key  
**CAL LED** flashes once.  
**MODE** display value is transferred to **OUTPUT** display.  
**MODE** display is cleared.  
**SET LED** goes **OFF**.

Not applicable if operation (g) omitted

Step	Calibration Operation	Shunt Value	Calibration Source Voltage <sup>[1]</sup>	4700 OUTPUT Current		AUTOCAL Key used <sup>[2]</sup>
				Range	OUTPUT Setting <sup>[1]</sup>	
1	100 $\mu$ A Range zero	10k $\Omega$	.0000000V	100 $\mu$	0.0000 $\mu$ A	—
2	100 $\mu$ A Range gain	10k $\Omega$	+ 1.0000000V	100 $\mu$	+100.0000 $\mu$ A	'SET' for non-nominal
3	1mA Range zero	1k $\Omega$	.0000000V	1m	.000000mA	—
4	1mA Range gain	1k $\Omega$	+ 1.0000000V	1m	+ 1.000000mA	'SET' for non-nominal
5	10mA Range zero	100 $\Omega$	.0000000V	10m	0.00000mA	—
6	10mA Range gain	100 $\Omega$	+ 1.0000000V	10m	+ 10.00000mA	'SET' for for-nominal
7	100mA Range zero	10 $\Omega$	.0000000V	100m	0.0000mA	—
8	100mA Range gain	10 $\Omega$	+ 1.0000000V	100m	+100.0000mA	'SET' for non-nominal
9	1A Range zero	0.1 $\Omega$	0.00000mV	1	.000000A	—
10	1A Range gain	0.1 $\Omega$	+100.00000mV	1	+ 1.000000A	'SET' for non-nominal

**Table 8.3 STEPS in DC CURRENT CALIBRATION**

**NOTES:** [1] It is expected that most users will wish to calibrate Range gains at values other than the nominals shown. In these cases set the Calibration Source voltage and the 4700 OUTPUT display to in-house standard values near nominal.

[2] At each step, use **CAL** key as a trigger (Refer to Calibration Routines).

# 4700 Resistance Calibration

## 1. Calibration Memory

In  $\Omega$  function, each RANGE key selects a nominal-value standard resistor. Routine adjustment of the resistor is not necessary. During calibration the actual value is measured and stored in the calibration memory to be displayed whenever that range is selected. Separate memory stores exist for Remote Sense (4-wire), Local Sense (2-wire) and Local Sense zero.

## 2. 4-Wire Calibration Limits

The value measured in 4-wire Remote Sense does not include the resistance of internal or external wiring. The 4700 accepts any value within  $\pm 200$  ppm of nominal as a valid calibration.

## 3. 2-Wire Calibration Limits

The value measured in 2-wire Local Sense is greater than for 4-wire Remote Sense, as it includes the resistance of internal wiring and relay contacts. The 4700 will not accept any 2-wire value less than the stored value for 4-wire, so the 4-wire Remote Sense calibration must be carried out before attempting 2-wire Local Sense. The extra internal resistance depends on Range, so the 4700 accepts the following values (x) as valid 2-wire calibrations:

Zero calibration.

10  $\Omega$  — 1 M $\Omega$  Ranges:  
 $0 \leq x < 0.900 \Omega$

Value calibrations.

10  $\Omega$  — 1 M $\Omega$  Ranges:  
 4-wire value  $\leq x < (4\text{-wire value} + 1.999 \Omega)$

## 4. "Error 6" message

"Error 6" appears on the MODE display for any attempt to enter a value outside the 4-wire or 2-wire limits quoted above.

**NOTE:** When resistance is calibrated in Remote Sense, the 4700 overwrites the Local Sense calibration memory with the new 4-wire value.

## 5. 4-wire and 2-wire Connections

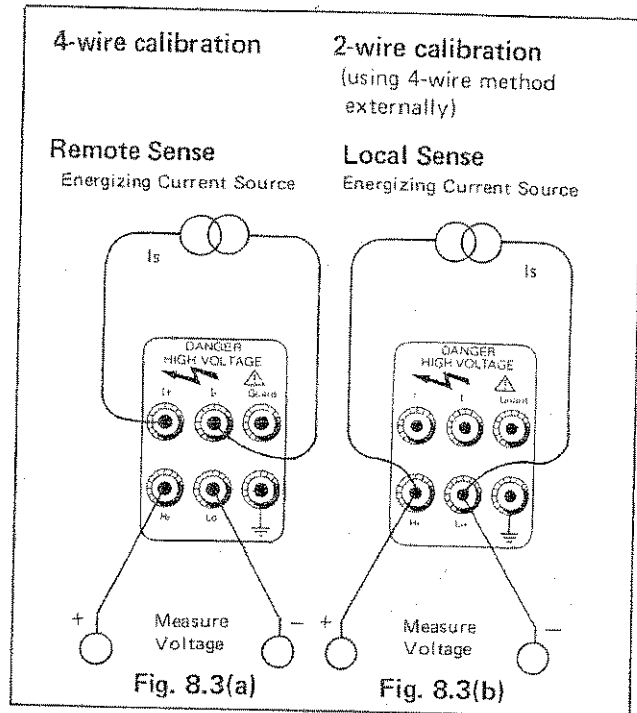

## 6. Calibration sequence

Press  $\Omega$  key and calibrate the resistors in the step sequence of Table 8.4 (a) and (b), using the Calibration Routine at para 7 (a) or (b). Refer to para 5 for connections to the measuring equipment. For 4-wire connections in Remote Sense (Fig. 8.3(a)) only the value of the internal Standard Resistor is measured. In Local Sense (Fig. 8.3 (b)) a 4-wire method is used to exclude the resistance of the external leads from the measured value.

## 7. Calibration Routine: Measurement and Storage of the values of an internal resistor.

- a) **Remote Sense** (Internal 4-wire, connected as Fig. 8.3(a))
 

Full Range values — Routine for Table 8.4(a)	
i) 4700	Select <b>OUTPUT OFF</b> and $\Omega$ .
ii) 4700	Select <b>Remote Sense</b> . Press required resistor (RANGE) key: The previously-calibrated value appears on the <b>OUTPUT</b> display.

- iii) 4700 and resistance-measuring equipment } Press **OUTPUT ON+** and measure the value of the internal resistor.
- iv) 4700 **OUTPUT** Set the **measured value** on the **OUTPUT** display.
- v) 4700 **CAL** Key Press to **store** **OUTPUT** display value.
- vi) 4700 Set **OUTPUT OFF**.
- vii) Repeat operations (ii) to (iv) for each step of Table 8.4(a).
- b) **Local Sense** (Internal 2-wire, connected as Fig. 8.3(b), Remote Sense **OFF**)  
Full Range and Zero values — Routine for Table 8.4(b)
  - i) 4700 Select **OUTPUT OFF** and  $\Omega$ .  
Deselect Remote Sense.
  - ii) 4700 Press required resistor (**RANGE**) key:  
The previously-calibrated value appears on the **OUTPUT** display.
  - iii) 4700 and resistance-measuring equipment } Press **OUTPUT ON+** and measure the value of the internal resistance.
  - iv) 4700 **OUTPUT** Set the **measured value** on the output display.
  - v) 4700 **CAL** Key Press to **store** **OUTPUT** display value.
  - vi) 4700 Zero Key Press and repeat operations (iii) to (v) for this **RANGE** selection.
  - vii) 4700 Set **OUTPUT OFF**.
  - viii) Repeat operations (ii) to (vii) for each step of Table 8.4(b).

**Table 8.4 STEPS IN RESISTANCE CALIBRATION**  
(Internal resistor value measurement and storage).

a) **Remote Sense** (Internal 4-wire, connect as Fig. 8.3a)  
Calibration at **Full Range**. Resolution  $7\frac{1}{2}$  digits, Tolerance  $\pm 199.9\text{ppm}$  ( $\pm 1999$  digits).

Step	Range	Measured resistance value, Calibration Limits		
1	100M $\Omega$	99.980,01	to 100.019,99	M $\Omega$
2	10M $\Omega$	9.998,001	to 10.001,999	M $\Omega$
3	1M $\Omega$	.999,800,1	to 1.000,199,9	M $\Omega$
4	100k $\Omega$	99.980,01	to 100.019,99	k $\Omega$
5	10k $\Omega$	9.998,001	to 10.001,999	k $\Omega$
6	1k $\Omega$	.999,800,1	to 1.000,199,9	k $\Omega$
7	100 $\Omega$	99,980,01	to 100.019,99	$\Omega$
8	10 $\Omega$	9.998,001	to 10.001,999	$\Omega$

b) **Local Sense** (Internal 2-wire, connect as Fig. 8.3(b), Remote Sense **OFF**)  
Calibration at **Full Range** and **Zero**. Resolution as listed in table.  
Tolerances  $-0\Omega + 1.999\Omega$  on 10 $\Omega$  - 1M $\Omega$  Ranges,  $-0\Omega + 0.900\Omega$  for zero on 10 $\Omega$  - 1M $\Omega$  Ranges.

Step	Range	Resolution (digits)	Resistance value Limits	Zero Limits	
9	1M $\Omega$	$7\frac{1}{2}$	Step 3 value, $-0 +19$ digits	.000,000,0	to .000,000,0 M $\Omega$
10	100k $\Omega$	$7\frac{1}{2}$	Step 4 value, $-0 +199$ digits	0.000,00	to 0.000,90 k $\Omega$
11	10k $\Omega$	$7\frac{1}{2}$	Step 5 value, $-0 +1999$ digits	0.000,000	to 0.000,900 k $\Omega$
12	1k $\Omega$	$6\frac{1}{2}$	Step 6 value, $-0 +1999$ digits	.000,000	to 0.000,900 k $\Omega$
13	100 $\Omega$	$5\frac{1}{2}$	Step 7 value, $-0 +1999$ digits	0.000	to 0.900 $\Omega$
14	10 $\Omega$	$4\frac{1}{2}$	Step 8 value, $-0 +1999$ digits	0.000	to 0.900 $\Omega$

# AC Calibration

## 'Wideband' Calibration

When CAL is pressed without preselecting SET,  $\pm 0$  or STD; the 4700 makes the assumption that each OUTPUT Range is to be calibrated at the exact Full Range value, at either LF or HF, or both.

This allows two correction values to be stored for each output range. From their difference, the microprocessor calculates a compensation factor, which affects the corrections applied at all subsequently-selected frequencies on that output range. In this way, the 4700 can be calibrated to meet its 'Wideband' specification.

To ensure that the selected Low and High frequencies have sufficient separation for the compensation to be effective over the full frequency range, calibration is automatically prohibited in an 'excluded' band of frequencies for each output range. Because of the extended frequency range of lower Voltage ranges, and the Voltage/Frequency constraints on higher Voltage ranges, the exclusion band can differ from one output range to another. If an excluded frequency is selected, the calibration is cancelled and Error 3 is displayed. The following diagram illustrates the mid-frequency exclusions:

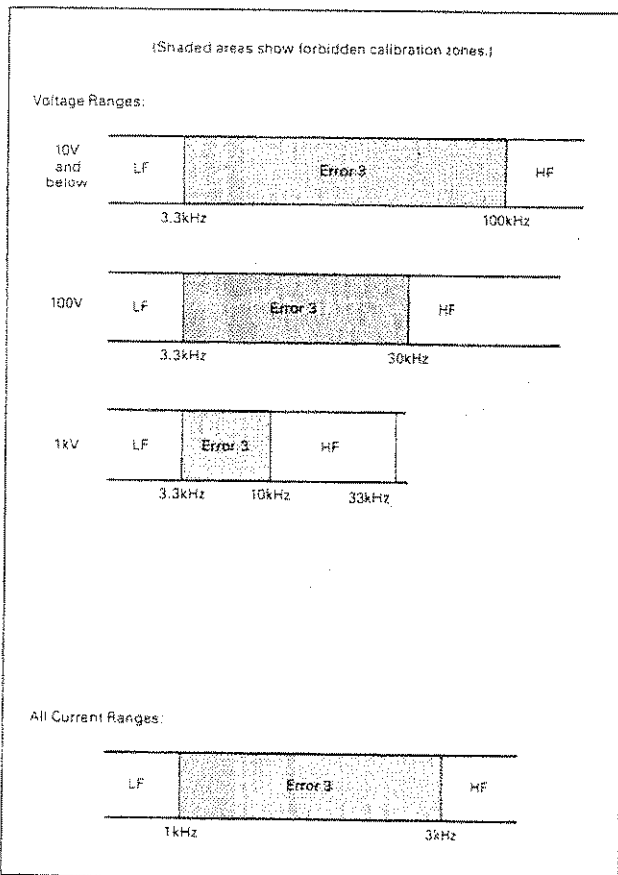

## SET Calibration

If Calibration is to be carried out with sources which are not exactly at Full Range, then the SET preselection key allows the 4700 to be prepared for calibration at other than its full range values. In this way the 4700 can be calibrated between 20% and 200% of full range, except for 1000V Range (20% to 110% - max. 1100V).

SET can also be used as a means of compensating for known errors in the Measurement System.

## $\pm 0$ Calibration.

(Not applicable for AC operation.)

## STANDARD Calibration

### CAUTION! This calibration affects all Voltage and Current Ranges!

STD calibration is designed for certain occasions when it is required to adjust the gain of all voltage and current ranges in the same ratio. The facility can be used to avoid a full recalibration of the 4700 when Laboratory References have been re-standardized, or when a 4700 has been moved from one country to another.

The STD facility is restricted to the 1V and 10V Ranges, on the 100Hz and 1kHz Frequency Ranges only. The procedure follows the SET procedure except that the STD key is pressed in place of the SET key. Pressing the CAL key to trigger the calibration adjusts all Voltage and Current Range gains in the same ratio,

# AC Calibration Sequence

## INTRODUCTION

Because most users will calibrate the 4700 via thermal transfer standards, the calibration procedures assume that this method will be employed. However, details of setting up a thermal transfer standard are not included, as several different models are in use, each with its own methods of connection and procedures.

Instead it is assumed that users will be able to operate their own equipment correctly, according to the manufacturer's instructions. The procedures which follow therefore concentrate on the operation of the 4700 during calibration, accepting that the required thermal transfer will be set up to a DC source of suitable accuracy.

## GENERAL PROCEDURE

**WARNING! During Performance checks and calibration the Full Range voltage is present at the Thermal Transfer Standard input terminals. On 1000V checks this voltage is potentially lethal, so EXTREME CAUTION must be observed when adjusting the Thermal Transfer Standard sensitivity.**

**Voltage Calibration using a Thermal Transfer**  
Select AC and the desired frequency, set the 4700 **OUTPUT** display to the Calibration Standard value, and switch the 4700 **OUTPUT ON**. If calibrating a non-nominal voltage value, **SET** needs to be selected. Adjust the 4700 output to obtain a null at the Calibration Standard value, and press the **Cal** key to execute the calibration.

### LF Millivolt Calibration

Because 'Flatness' data is passed on to the millivolt ranges from the 1V Range calibration, the 1V range must be calibrated first. A DVM is then standardized at the required millivolt value and frequency, using the calibrated 1V Range and an Inductive Voltage Divider (IVD). The desired frequency is selected, the **OUTPUT** display set to Full Range, and incremented or decremented to give the required value on the DVM. If calibrating at a non-nominal value **SET** must be selected. The **CAL** key is pressed to execute the calibration.

### HF Millivolt Calibration

From the 10V Range a 10% Range correction is calculated. This is applied at 100mV on the 1V Range to standardize a DVM, which is subsequently used to calibrate the 100mV Full Range. The

process is extended to calibrate the 10mV Range from 10% of the 100mV Range, and 1mV Range from 10% of the 10mV Range.

### Current Calibration

(Using Thermal Transfer Standard Current Shunts)

The method employs a DC Current Standard, so that the shunt remains connected for both AC and DC nulling of the Thermal Transfer Standard.

Otherwise the procedure is similar to that for DC Voltage Calibration.

### Alternative Current Calibration

(Using Calibrated Standard AC Current Shunts)

This method requires Standard Current Shunts which have been designed to give a flat frequency response. Each current range requires its own specific value of shunt, calibrated to develop either 1V or 100mV Full Range at LF and HF. An AC DVM is standardized to the appropriate voltage, and the Current range is calibrated when the voltage across its shunt is correct. The method is detailed in Appendix 1 to this section.

### Standardization

To 'Standardize' all Ranges: The Voltage procedure is used, but pressing **STD** instead of **SET** on the 1V/10V Range.

**CAUTION! Do not 'Standardize' unless it is necessary for the reasons quoted on page 8-12.**



## GENERAL NOTES

Remote Sense is available as follows:

1V 10V 100V 1000V - Local/Remote Sense  
1mV 10mV 100mV - Local Sense only  
All current ranges - not applicable  
(Local: 2-wire sense, Remote: 4-wire sense)  
Output must be **OFF** to change sense connection  
(except that Remote changes automatically to Local  
when switching to Millivolt Ranges).

### Up-ranging - OUTPUT OFF Default

The 4700 cannot enter High-Voltage state (>75V RMS) with OUTPUT ON. Consequently, when ranging-up, the operating system allows the up-ranging to occur, but defaults to OUTPUT OFF for two specific cases:

- a. When up-ranging to the 1000V Range,
- b. When up-ranging to the 100V Range to a voltage of 75V or more.

Otherwise, OUTPUT remains ON when changing OUTPUT RANGE (refer to Section 4, pages 4-7 to 4-9).

### High Frequency Calibrations

Several passes may be required to achieve satisfactory calibration, particularly if the initial errors are large or the calibration takes longer than required by the Transfer System in use. Repeat procedure as required.

### 1000V Range Calibration Sequence:

LF calibration must be completed first.

### Preparation

Before any calibration is carried out, prepare the 4700 as follows:

1. Turn on the instrument to be checked and allow minimum of 4 hours to warm up in the specified environment.
2. Ensure familiarity with normal operation of the 4700 described in this Handbook.
3. Refer to 'Equipment Requirements' in Section 7; the same equipment and techniques used for verification are also applicable to calibration.
4. Consult the manufacturer's handbooks before connecting and operating the Thermal Transfer Std, DC Voltage Std., Inductive Voltage Divider, AC DVM, and Thermal Transfer Standard Current Shunts.

5. Interconnections and Guarding: Refer to Section 4, page 4-1.

6. Cancel any **MODE** keys, ensure **OUTPUT** set to **OFF**.

7. IEEE 488 Address switch:  
Set to **ADD 11111** (Address 31) unless the 4700 is to be calibrated via the IEEE 488 interface.

8. **CALIBRATION ENABLE** key switch:  
Insert Calibration Key and turn to **ENABLE**.

9. Set the Calibration Interval Switch to **24 hr**.

### WARNING

During calibration, the Full Range voltage is present at the Thermal Transfer Standard input terminals. On 1000V checks this voltage is potentially lethal, so **EXTREME CAUTION** must be observed when making adjustments to the Thermal Transfer Standard sensitivity.

# 4700 AC Voltage Calibration (1V - 1000V)

(Using Thermal Transfer Standard and DC Calibration Standard)

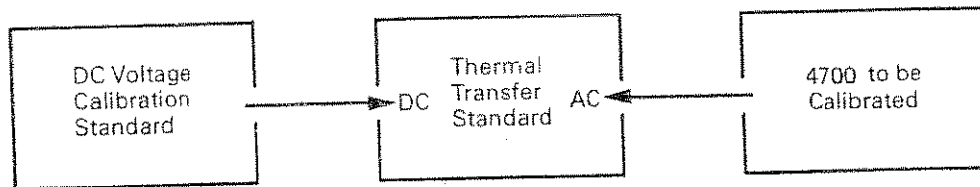

Calibrate the 4700 at or close to the calibration points in the table, selecting SET as required as part of the following procedure:

## WARNING:

THE TERMINALS MARKED WITH THE ⚡SYMBOL CARRY THE OUTPUT OF THE 4700. THESE TERMINALS AND ANY OTHER CONNECTIONS TO THE LOAD UNDER TEST COULD CARRY LETHAL VOLTAGES. UNDER NO CIRCUMSTANCES SHOULD USERS TOUCH ANY OF THE FRONT (OR REAR) PANEL TERMINALS UNLESS THEY ARE FIRST SATISFIED THAT NO DANGEROUS VOLTAGE IS PRESENT.

### 1. 4700 & DC Voltage Standard

With OUTPUT OFF, connect to the Thermal Transfer AC and DC inputs, respectively.

### 2. Thermal Transfer Standard

Configure for DC measurement at the required Calibration Voltage.

### 3. DC Voltage Calibration Standard

Set to the Cal Voltage, OUTPUT ON.

### 4. Thermal Transfer Standard

- Adjust for Null at the Cal. Voltage.
- Configure for AC measurement at the Calibration Voltage.

### 5. 4700

- On AC FUNCTION, select the required OUTPUT RANGE.
- Select the required FREQUENCY RANGE
- Use FREQUENCY  $\uparrow\downarrow$  keys to display the required Cal. Frequency.
- Use OUTPUT  $\uparrow\downarrow$  keys to display the required Cal. Voltage (if at Nominal Full Range, merely press the Full Range key).
- Set 4700 OUTPUT ON (and if NOT at Nominal Full Range, Select SET).
- Use the OUTPUT  $\uparrow\downarrow$  keys to adjust the OUTPUT Display reading to obtain a null on the Thermal Transfer.
- Execute the calibration by pressing the CAL key.

Nominal Cal. Points for 1V to 1000V Ranges.

DC Standard OUTPUT Voltage	4700 OUTPUT RANGE/ FREQUENCY	4700 Nominal OUTPUT Voltage	Freq. Band set by 4700
1.000000V	1V 1kHz	1.000000V	LF
1.000000V	1V 1MHz	1.000000V	* HF
10.00000V	10V 1kHz	10.00000V	LF
10.00000V	10V 1MHz	10.00000V	* HF
100.0000V	100V 1kHz	100.0000V	LF
100.0000V	100V 100kHz	100.0000V	HF
1000.000V	1000V 1kHz	1000.000V	LF
1000.000V	1000V 30kHz	1000.000V	HF

\*6. 2-wire HF Calibration (1V and 10V ranges - see table above)

**NOTE:** It is important that 4-wire and 2-wire calibrations are carried out in the correct sequence. Two stores are used, one for 4-wire (which sets the master HF cal), and the other containing the corrections to the 4-wire figures for 2-wire. The correct procedure is:

- (a) Select 1V or 10V range.
- (b) Select Remote Sense.
- (c) Do a 4-wire HF calibration as normal. This changes the numbers in the 4-wire calstore and clears the 2-wire calstore to zero.
- (d) Deselect Remote Sense
- (e) Do another HF calibration. This sets the correction numbers into the 2-wire calstore. If Remote Sense is deselected, only the 2-wire calibration is performed.

# 4700 AC Millivolts (LF) Calibration (1mV - 100mV)

(Using calibrated 4700 1V Range, Inductive Voltage Divider (IVD) and AC DVM)

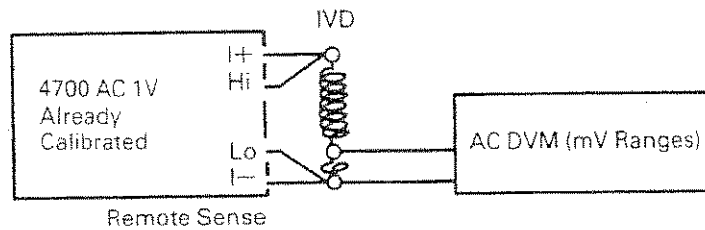

Standardization of DVM Millivolt Ranges

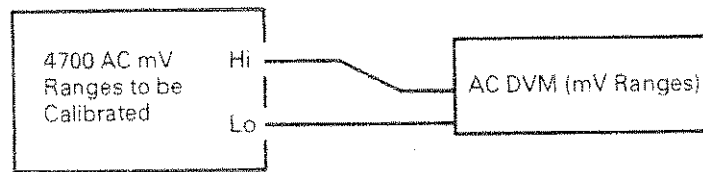

Calibration of 4700 LF Millivolt Ranges

Calibrate the 4700 at or close to the calibration points in the table, selecting SET as required as part of the following procedure:

**1. 4700, IVD and AC DVM**

With OUTPUT OFF, connect the circuit for Standardization.

**2. IVD**

Set ratio as required for the Millivolt Range to be calibrated.

**3. AC DVM**

Configure for measurement at the required Calibration Point.

**4. 4700**

a. On AC FUNCTION, select 1V RANGE.

b. Select the required Frequency Range.

c. Use FREQUENCY  $\uparrow/\downarrow$  keys to display the required Cal. Frequency.

d. Use OUTPUT  $\uparrow/\downarrow$  keys to display the required IVD input voltage (if at Nominal Full Range, merely press the Full Range key).

e. Set OUTPUT ON; note DVM reading as VI.

f. Set OUTPUT OFF, and reconnect the circuit for Calibration.

g. Select the required Millivolt OUTPUT RANGE.

h. Use OUTPUT  $\uparrow/\downarrow$  keys to display the Cal. Voltage on the OUTPUT Display (if at Nominal Full Range, merely press the Full Range key).

j. Set 4700 OUTPUT ON (and if NOT at Nominal Full Range, Select SET).

k. Use the  $\uparrow/\downarrow$  keys to adjust the OUTPUT Display reading to obtain VI on the DVM.

l. Execute the calibration by pressing the CAL key. Set OUTPUT OFF.

Nominal Cal. Points for Millivolt Ranges.

IVD Ratio (1V Range to mV Range)	4700 OUTPUT RANGE/FREQUENCY	4700 Nominal OUTPUT Voltage	Freq. Band set by 4700
10 : 1	100mV 1kHz	100.0000mV	LF
100 : 1	10mV 1kHz	10.0000mV	LF
1000 : 1	1mV 1kHz	1.0000mV	LF

# 4700 AC Millivolts (HF) Calibration (1mV - 100mV)

(Using verified 4700 AC 1V and 10V Ranges, 10% Range Correction Factor and AC DVM).

### Summary

The verified AC output values of 1V on the 1V Range; and 10V on the 10V Range are used to measure the 4700 linearity error at 1V on the 10V range. From the linearity measurement, a 10% of range Linearity and Scaling Factor 'C' is derived.

This factor is subsequently used to correct the 4700 output setting at 10% of range, to standardize a DVM for calibration of the next range down.

Calibrate the 4700 at or close to the calibration points in the table.

N.B. These calibrations are not fully traceable.

### Note:

It is assumed that the 1V and 10V ranges have been calibrated at the required HF calibration points. It is also assumed that the Millivolt (LF) Calibration has been completed.

### Interconnections

FIG 1 (10V and 1V Ranges)

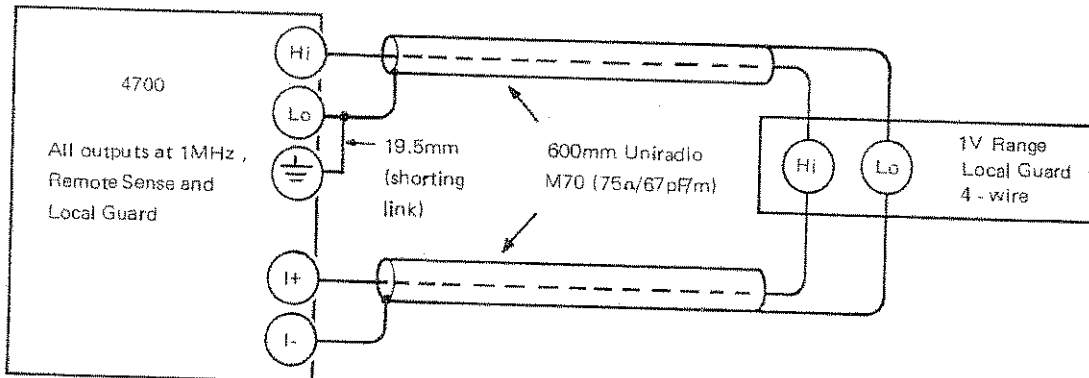
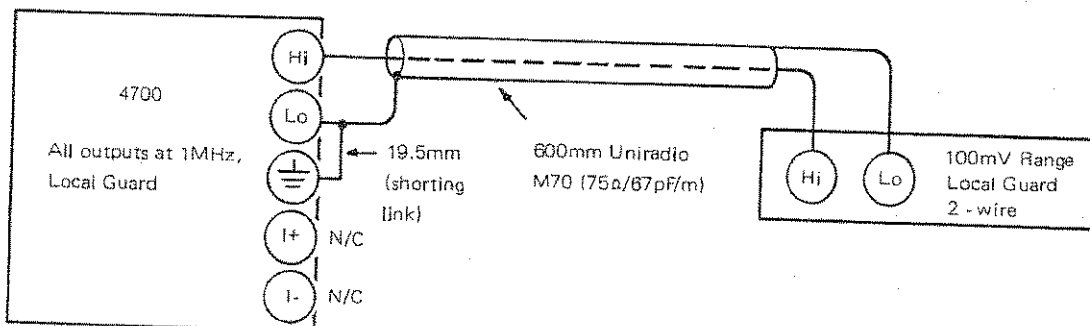

FIG 2 (100mV to 1mV Ranges)



Nominal Cal. Points for HF Millivolt Ranges

4700 AC OUTPUT RANGE/ FREQUENCY	4700 Nominal OUTPUT Voltage	Freq. Band set by 4700
100mV 1MHz	100.0000mV	HF
10mV 1MHz	10.0000mV	HF
1mV 1MHz	1.0000mV	HF

Stage 1 Derive the Linearity and Scaling Factor 'C' as follows (C is a number of value close to 0.1):

- a. Ensure that the Millivolts (LF) Calibration has been completed.  
 Ensure that the 4700 has been calibrated and verified at AC 10V and 1V HF (1MHz) Full Range. Record the measured values as follows:  
  
 4700 10V FR setting — 10.000,00V  
 Actual output voltage — 'V1'  
  
 4700 1V FR setting — 1.000,000V  
 Actual output voltage — 'V2'
- b. Calculate 1V correction 'V3' =  $\frac{1}{V2}$
- c. With OUTPUT OFF connect a DVM to the 4700 terminals using the exact 4-wire connections as in Fig. 1. Set the DVM to measure AC on its 1V range.
- d. On 4700, select the 1V range and Remote Sense.  
 Set FREQUENCY to 1MHz.  
 Set OUTPUT display reading to V3.  
 Set OUTPUT ON, and note the DVM reading as 'Vt'.  
 Set OUTPUT OFF.
- e. On 4700, select the 10V range (Remote Sense).  
 Set 4700 OUTPUT display reading to 1V.  
 Set OUTPUT ON.  
 Adjust the OUTPUT display for a DVM reading of Vt.
- f. Note the 4700 OUTPUT display reading as 'V4'.  
 Set OUTPUT OFF.
- g. From the values V1 and V4 calculate the 10V range linearity correction and scaling factor 'C' as follows:

$$C = \frac{V1 \times V4}{100}$$

Note:

The optimum resolution quoted above the boxes in this column may not be achievable with the DVM in use. In these cases it is permissible to reduce the resolution by a maximum of 1 digit only.

Record in 6½ digits resolution

V1 =
V2 =
V3 =

Vt is a transfer value

Vt =
------

Record in 6½ digits resolution

V4 =
------

Calculate in 6½ digits resolution

C =
-----

N.B. The following calibration from the front panel can only be carried out if the IEEE Address switch on the rear panel is set to Address 31 (11111).

**Stage 2 To Calibrate the AC 100mV Range Full Range Output**

- a. Insert the Calibration security key into the 'CALIBRATION ENABLE' switch on the rear panel, and turn to 'ENABLE'.
- b. Ensure that the DVM is still connected to the 4700 terminals as shown in Fig. 1.
- c. Set the 4700 to the AC IV range. Calculate the value ' $V3 \times C$ '. Set OUTPUT display to this value.
- d. Set the AC DVM to measure 100mV.
- e. Set 4700 OUTPUT ON, allow the output to settle. Note the DVM reading as ' $V(100t)$ '.
- f. Set 4700 OUTPUT OFF and reconnect the DVM to the 4700 terminals in 2-wire as shown in Fig. 2.
- g. Set 4700 to its AC 100mV range. (Remote Sense is automatically deselected.) Set OUTPUT ON and adjust the 4700 Output for a DVM reading of  $V(100t)$ . Press the 'CAL' pushbutton and observe the DVM reading.
- h. Repeat operation (g) until the post-CAL DVM reading is within  $1\mu V$  of  $V(100t)$ . (If calibrating a Spot Frequency, re-press the SPOT key to deselect).

**Stage 3 To Calibrate the AC 10mV Range Full Range Output**

- a. Ensure that the DVM is still connected to the 4700 terminals as shown in Fig. 2. Reselect the Spot Frequency if required.
- b. Ensure that the 4700 is set to the AC 100mV range. Calculate the value ' $100mV \times C$ '. Set OUTPUT display to this value.
- c. Set the AC DVM to measure 10mV.
- d. Allow the output to settle. Note the DVM reading as ' $V(10t)$ '.
- e. Set 4700 to its AC 10mV range.

f. Adjust the 4700 Output for a DVM reading of  $V(10t)$ . Press the 'CAL' pushbutton and observe the DVM reading.

g. Repeat operation (f) until the post-CAL DVM reading is within  $1\mu V$  of  $V(10t)$ . Deselect the Spot Frequency if selected at (a).

Calculate in  $6\frac{1}{2}$  digits resolution

$$V3 \times C =$$

$V(100t)$  is a transfer value

$$V(100t) =$$

Calculate in  $6\frac{1}{2}$  digits resolution

$$100mV \times C =$$

$V(10t)$  is a transfer value

$$V(10t) =$$

**Stage 4 To Calibrate the 1mV Range Full Range Output**

- a. Ensure that the DVM is still connected to the 4700 terminals as shown in Fig. 2.
- b. Ensure that the 4700 is set to the 10mV range.  
Calculate the value '10mV x C'.  
Set OUTPUT display to this value.
- c. Set the DVM to measure 1mV.
- d. Allow the output to settle.  
Note the DVM reading as 'V(lt)'.
- e. Set 4700 to its 1mV range.
- f. Adjust the 4700 Output to give a settled DVM reading of V(lt).  
Press the 'CAL' pushbutton and observe the DVM reading.
- g. Repeat operation (f) until the post-CAL DVM reading is within 1uV of V(lt).

Calculate in 5½ digits resolution

$10\text{mV} \times C =$
--------------------------

V(lt) is a transfer value

$V(\text{lt}) =$
------------------

**Stage 5 Calibration Disable**

- a. Turn the Calibration security key, inserted in the 'CALIBRATION ENABLE' switch on the rear panel, to 'RUN'. Remove the key.



# 4700 AC Current Calibration (1mA - 1A)

(Using Thermal Transfer, Current Shunts and DC Current Standard)

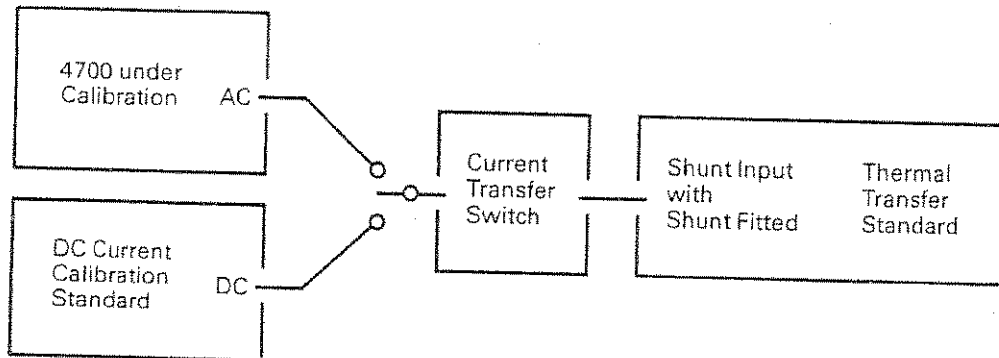

Calibrate the 4700 at or close to the calibration points in the table, selecting SET as required as part of the following procedure:

Calibrate 1mA Range only if the Thermal Transfer is adequately calibrated at these levels.

## 1. Thermal Transfer Standard

Configure for DC measurement at the required Cal. Current and connect the appropriate shunt.

## 2. DC Current Standard

a. With OUTPUT OFF, connect across the Thermal Transfer shunt, and set to the required Cal. Current.

b. Set OUTPUT ON.

## 3. Thermal Transfer Standard

Adjust for null at the Cal. Current.

## 4. DC Current Standard

a. Set OUTPUT OFF.

b. Disconnect from the shunt.

## 5. 4700

a. With OUTPUT OFF, connect the I+ and I- terminals across the Shunt.

b. On ACI FUNCTION, select the required OUTPUT RANGE.

c. Select the required FREQUENCY RANGE.

d. Use FREQUENCY  $\uparrow/\downarrow$  keys to display the required Cal. Frequency.

e. Use OUTPUT  $\uparrow/\downarrow$  keys to display the required Cal. Current (if at Nominal Full Range, press the Full Range key).

f. Set 4700 OUTPUT ON (and if NOT at Nominal Full Range, Select SET).

g. Use the OUTPUT  $\uparrow/\downarrow$  keys to adjust the OUTPUT Display reading to obtain a null on the Thermal Transfer.

h. Execute the calibration by pressing the CAL key. Set OUTPUT OFF.

Nominal Cal. Points for 1mA to 1A Ranges.

DC Standard OUTPUT Current	4700 OUTPUT RANGE/ FREQUENCY	4700 Nominal OUTPUT Current	Freq. Band set by 4700
1.000000mA	1mA 300Hz	1.000000mA	LF
1.000000mA	1mA 5kHz	1.000000mA	HF
10.000000mA	10mA 300Hz	10.000000mA	LF
10.000000mA	10mA 5kHz	10.000000mA	HF
100.000000mA	100mA 300Hz	100.000000mA	LF
100.000000mA	100mA 5kHz	100.000000mA	HF
1.0000000A	1A 300Hz	1.0000000A	LF
1.0000000A	1A 5kHz	1.0000000A	HF

## APPENDIX 1 4700 AC Current Calibration (100 $\mu$ A - 1A)

(Using verified 4700 1V Range, Calibrated Standard AC Shunts and AC DVM)

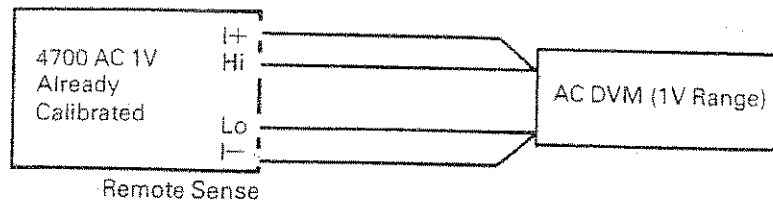

Standardization of DVM 1V Range

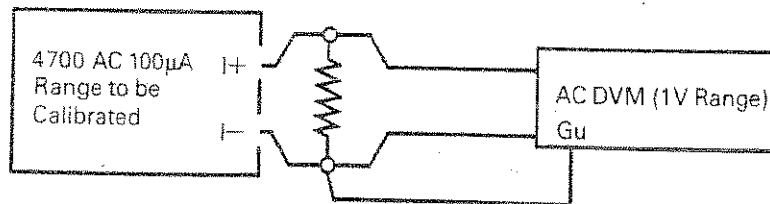

Calibration of 4700 Current Ranges

Calibrate the 4700 at or close to the calibration points in the table, selecting SET as required as part of the following procedure:

### 1. 4700 and AC DVM

With OUTPUT OFF, connect the 4700 and DVM for Standardization. Select 1V Range on the AC DVM.

### 2. 4700

- Set to 1V Range at the Calibration Frequency and adjust for calibrated 1.000000V output.
- Set OUTPUT ON and note the DVM reading as VI.
- Set OUTPUT OFF, and reconnect the test circuit for Calibration, using the correct shunt for the range to be calibrated.
- On ACI FUNCTION, select the required OUTPUT RANGE.
- Select the required FREQUENCY RANGE.
- Use FREQUENCY  $\uparrow/\downarrow$  keys to display the required Cal. Frequency.
- Use OUTPUT  $\uparrow/\downarrow$  keys to display the required Cal. Current (if at Nominal Full Range, press the Full Range key).
- Set 4700 OUTPUT ON (and if NOT AT Nominal Full Range, Select SET).

j. Use the OUTPUT  $\uparrow/\downarrow$  keys to adjust the OUTPUT Display reading to obtain a DVM reading of VI.

k. Execute the calibration by pressing the Cal key. Set OUTPUT OFF.

Nominal Cal. Points for 100 $\mu$ A to 1A Ranges.

4700 OUTPUT RANGE/ FREQUENCY	4700 Nominal OUTPUT Current	Freq. Band set by 4700
100 $\mu$ A 300Hz	100.0000 $\mu$ A	LF
100 $\mu$ A 5kHz	100.0000 $\mu$ A	HF
1mA 300Hz	1.000000mA	LF
1mA 5kHz	1.000000mA	HF
10mA 300Hz	10.00000mA	LF
10mA 5kHz	10.00000mA	HF
100mA 300Hz	100.0000mA	LF
100mA 5kHz	100.000mA	HF
1A 300Hz	1.000000A	LF
1A 5kHz	1.000000A	HF