

# MODEL 253

## Autoranging Digital Impedance Meter

### Instruction Manual

Part Number 43761B

June 1985

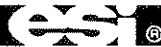
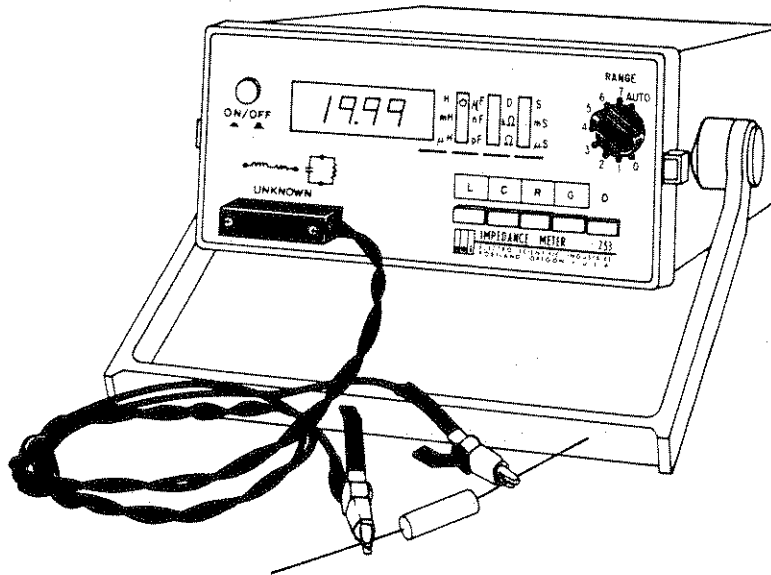

Electro Scientific Industries, Inc.

13900 N.W. Science Park Drive • Portland, Oregon 97229 • Telephone: (503) 641-4141 • Telex 4742064

©Copyright 1979 Electro Scientific Industries, Inc.  
All rights reserved • Litho in U.S.A.

ESI® Reserves the right to change specifications  
and other product information without notice.

# PROTECT AGAINST ELECTROSTATIC DISCHARGE

In this instrument there are MOSFET semiconductors, which can be damaged by electrostatic discharge during handling. The following precautionary procedures are recommended to minimize this possibility.



**HANDLE STATIC SENSITIVE DEVICES ONLY AT A GROUNDING, STATIC-FREE WORK STATION**

**HANDLE DEVICES BY THE BODY. DO NOT TOUCH THE DEVICE LEADS.**



**BE SURE YOUR SOLDERING IRON TIP IS GROUNDING AND DO NOT USE SOLDER-SUCKERS THAT ARE NOT ANTI-STATIC PROTECTED**

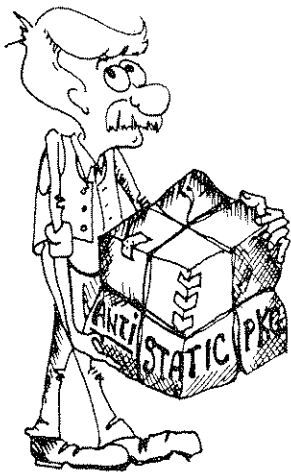

**USE ANTI-STATIC PACKAGING FOR HANDLING AND TRANSPORT**

**KEEP PARTS IN MANUFACTURER'S PROTECTED CONTAINERS**

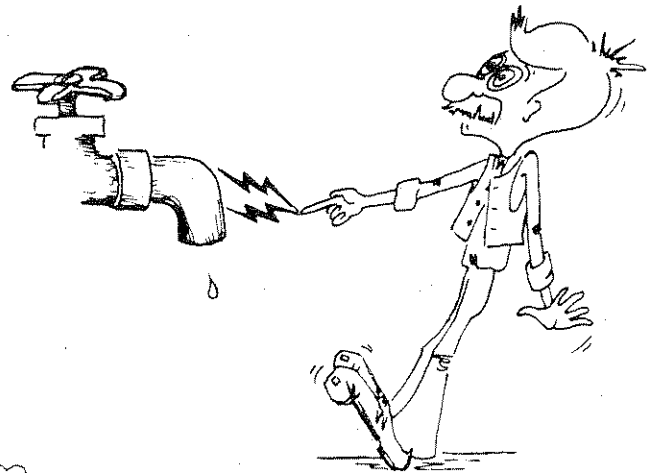

**DISCHARGE PERSONAL STATIC BEFORE HANDLING DEVICES**



**AVOID HANDLING WHENEVER POSSIBLE**

**DO NOT SLIDE STATIC SENSITIVE DEVICES OVER ANY SURFACE AND AVOID PLASTIC, VINYL AND STYROFOAM IN WORK AREAS**

0  
1  
2  
3  
4  
5  
6  
7  
8  
9  
A  
B  
C  
D  
E  
F  
G  
H  
I  
J  
K  
L  
M  
N  
O  
P  
Q  
R  
S  
T  
U  
V  
W  
X  
Y  
Z

## TABLE OF CONTENTS

**WARNING**

DANGEROUS VOLTAGE POTENTIALS EXIST INSIDE THIS INSTRUMENT. MAINTENANCE INSTRUCTIONS WITHIN THIS MANUAL ARE FOR USE BY QUALIFIED SERVICE PERSONNEL ONLY. TO AVOID ELECTRICAL SHOCK, DO NOT ATTEMPT ANY SERVICING OTHER THAN THAT CONTAINED IN THE OPERATION INSTRUCTIONS UNLESS YOU ARE QUALIFIED TO DO SO.

1	DESCRIPTION	
1.1	INTRODUCTION	1-1
1.2	SPECIFICATIONS	1-2
2	OPERATION	
2.1	CONTROLS AND CONNECTORS	2-1
2.1.1	Front Panel	2-1
2.1.2	Rear Panel	2-3
2.2	OPERATING PROCEDURE	2-4
2.2.1	Power Requirements	2-4
2.2.2	Applying Power	2-5
2.2.3	Connection to Unknowns	2-5
2.2.3.1	Test Fixture Compensation	2-7
2.2.4	Function Selection	2-9
2.2.5	Range Selection	2-12
2.2.6	Summary of Operation	2-14
2.3	MEASUREMENT TECHNIQUES	2-15
2.3.1	Resistance Measurements at 1kHz	2-15
2.3.2	Capacitance Measurements	2-15
2.3.3	Inductance Measurements	2-18
2.3.4	Determining Quality Factor (Q) of Inductors	2-19
2.3.5	Determining Dissipation Factor (D) of Capacitors using Nomograph	2-20
2.3.6	Using the Bias Feature	2-22
2.3.7	Signal Output Terminals	2-23
2.3.8	Measuring Grounded Unknowns	2-23
2.3.9	Measuring Battery Impedance	2-26
2.3.10	Component Sorting	2-28
3	CIRCUIT DESCRIPTIONS	
3.1	GENERAL DESCRIPTION	3-1

## TABLE OF CONTENTS (continued)

3.2	DETAILED CIRCUIT DESCRIPTIONS	3-2
3.2.1	1kHz Oscillator	3-3
3.2.2	Unknown Differential Amplifier	3-3
3.2.3	Range Amplifier	3-3
3.2.4	Reference Generator and Phase Sensitive Detector	3-4
3.2.5	Dissipation Factor Circuit	3-4
3.2.6	Overload Blanking Circuit	3-5
3.2.7	Analog to Digital Converter	3-5
3.2.8	Function and Range Programming	3-5
3.2.9	Auto Range Circuit	3-6
4	MAINTENANCE	
4.1	CALIBRATION PROCEDURE	4-1
4.1.1	Power Supply Check	4-2
4.1.2	Oscillator Adjust	4-2
4.1.3	L, C, R, G Alignment	4-2
4.1.4	Dissipation Factor (D) Alignment	4-3
4.2	MAINTENANCE	4-7
4.2.1	Preventive Maintenance	4-7
4.2.1.1	Cleaning	4-7
4.2.1.2	Visual Inspection	4-8
4.2.2	Troubleshooting	4-8
4.2.2.1	Troubleshooting Aids	4-8
4.2.2.2	Troubleshooting Procedure	4-9
4.3	CORRECTIVE MAINTENANCE	4-12
4.3.1	Obtaining Replacement Parts	4-12
4.3.2	Component Replacement Parts	4-13
4.4	REPACKING FOR SHIPMENT	4-14
5	PARTS LISTS AND DIAGRAMS	
5.1	MAINFRAME PARTS	5-1
5.2	MOTHERBOARD CIRCUIT ASSEMBLY	5-2
5.3	DISPLAY CIRCUIT ASSEMBLY	5-8
5.4	AUTORANGE CIRCUIT ASSEMBLY	5-10
5.5	REAR PANEL ASSEMBLY	5-12
5.6	POWER SUPPLY CIRCUIT ASSEMBLY	5-14

# SECTION 1

## DESCRIPTION

### 1.1 INTRODUCTION

The ESI Model 253 Digital Impedance Meter is a semi-automatic instrument which permits rapid measurement of inductance (L), capacitance (C), resistance (R), conductance (G), and dissipation factor (D) at a test frequency of 1kHz. Measurement accuracy and versatility satisfies most demanding engineering or scientific applications.

This instrument has both an autoranging mode and a manual range selection mode. The autoranging feature eliminates the need for manual range selecting, thus saving time and avoiding operator errors. It is designed to measure an unknown and select the lowest corresponding range automatically, thereby providing the highest resolution display. When a series of measurements are to be made within a particular range, time can be saved by turning the range switch to the corresponding fixed range position. Front panel LED lamps indicate the unit of measurement being displayed by the 3-1/2 digit LED readout.

To operate, merely push the button for the desired function, manually turn the knob to the desired range, and connect the unknown. KELVIN KLIPS® test leads are included, thus ensuring true four-terminal connections.

Excellent reliability of the Model 253 is assured through use of solid state devices and etched circuit board construction. Its small size is ideal for use on benchtops where work space may be at a premium. The carrying handle tilts the unit to a convenient viewing angle. Rear panel brackets provide line cord storage and enable it to be operated in a vertical position.

## 1.2 SPECIFICATIONS

		Ranges							
		0	1	2	3	4	5	6	7
Full Scale Values	L <sub>s</sub>	200 μH	2 mH	20 mH	200 mH	2 H	20 H	200 H	200 H
	C <sub>p</sub>	200 pF	2 nF	20 nF	200 nF	2 μF	20 μF	200 μF	2000 μF
	R <sub>s</sub>	2 Ω	20 Ω	200 Ω	2000 Ω	20 kΩ	200 kΩ	2000 kΩ	2000 kΩ
	G <sub>p</sub>	2 μS	20 μS	200 μS	2000 μS	20 mS	200 mS	2000 mS	20 S
	D	1999							
Accuracy (15°C to 35°C)	L <sub>s</sub>	±[0.25% + (1 + 0.002R <sub>s</sub> <sup>*</sup> ) digits]**	±[0.25% + (1 + 0.001R <sub>s</sub> <sup>*</sup> ) digits]					±[0.25% + (1 + 0.002R <sub>s</sub> <sup>*</sup> ) digits]	±[0.25% + (1 + 0.002R <sub>s</sub> <sup>*</sup> ) digits]
	C <sub>p</sub>	±[0.25% + (1 + 0.002G <sub>p</sub> <sup>*</sup> ) digits]**	±[0.25% + (1 + 0.001G <sub>p</sub> <sup>*</sup> ) digits]					±[0.25% + (1 + 0.002G <sub>p</sub> <sup>*</sup> ) digits]	±[0.5% + (1 + 0.004G <sub>p</sub> <sup>*</sup> ) digits]
	R <sub>s</sub>	±[0.25% + (1 + 0.002L <sub>s</sub> <sup>*</sup> ) digits]	±[0.25% + (1 + 0.001L <sub>s</sub> <sup>*</sup> ) digits]					±[0.25% + (1 + 0.002L <sub>s</sub> <sup>*</sup> ) digits]	±[0.25% + (1 + 0.002L <sub>s</sub> <sup>*</sup> ) digits]
	G <sub>p</sub>	±[0.25% + (1 + 0.002C <sub>p</sub> <sup>*</sup> ) digits]	±[0.25% + (1 + 0.001C <sub>p</sub> <sup>*</sup> ) digits]					±[0.25% + (1 + 0.002C <sub>p</sub> <sup>*</sup> ) digits]	±[0.5% + (1 + 0.004C <sub>p</sub> <sup>*</sup> ) digits]
	D	±(1% + 0.002) for L or C ≥ 200 counts ±(2% + 0.010) for L or C 50 to 199 counts							±(2% + 0.010)
Test Signal	Voltage C <sub>p</sub> , G <sub>p</sub>	1.0 VRMS			0.1 VRMS				0.01 VRMS
	Current L <sub>s</sub> , R <sub>s</sub>	100 mA	10 mA	1 mA	100 μA	10 μA		1 μA	

\*Digit count, same range.

\*\*After correction for test lead zero reading.  
0°C to 15°C and 35°C to 50°C: add 0.1(rated accuracy)/°C.

Table 1-1. Model 253 Specifications

Test Frequency: 1kHz ±1%

Unknown Excitation: The 1kHz voltage (V<sub>x</sub>) and current (I<sub>x</sub>) levels listed in Table 1-1 are held constant by an internal amplitude control circuit.

Measurement Rate: Four per second; one second is required for first reading after connecting unknown to terminals.

Measurement Display: 3-1/2 digit LED with decimal point. Blanked for overload conditions.

Unit Display: Unit of measurement being displayed by the LED readout is indicated by front panel LED lamps used in conjunction with the desired function button and the front panel range switch or autoranging mode.

External Bias: Rear panel terminals are provided for connection of external supply. 0V to 50VDC, 0.1A maximum. (Read Section 2.2.6 before using external bias.)

Static Charge Protection: Diode and resistor discharge network.



Connection to Unknown: Four-terminal, shielded, connections are provided by the KELVIN KLIPS® cable assembly (ESI Part Number 43072) supplied with the Model 253.

Outputs: Analog signals of 1V per 1,000 counts, 1k $\Omega$  source resistance is available at rear panel. L, C, R, or G, with simultaneous output of D for L or C.

Power Consumption: 4 watts typical.

Power Requirements: 100 to 125V or 200 to 250V, 50/60Hz.

Fuse: 110V: 1/16A, 250VAC Slow Blow  
220V: 1/20A, 250VAC Slow Blow

Size: Height (with feet) - 100mm (4 in.)  
Width - 260mm (10 in.)  
Depth (overall) - 370mm (14.6 in.)

Weight: 3.2kg (7 lb).

Accessories supplied with Model 253:

	ESI Part No.
KELVIN KLIPS® Four-Terminal Clips	43072
Instruction Manual	43761

Options Available:

	ESI Part No.
Model 1412B Universal Limits Comparator	31412B
Sorting Fixture Model 2001 (low frequency)	32001
Cable Assembly (for Model 2001 connection)	43586
Front Panel Dust Cover	43374

1  
2  
3  
4  
5  
6  
7  
8  
9  
10  
11  
12  
13  
14  
15  
16  
17  
18  
19  
20  
21  
22  
23  
24  
25  
26  
27  
28  
29  
30  
31  
32  
33  
34  
35  
36  
37  
38  
39  
40  
41  
42  
43  
44  
45  
46  
47  
48  
49  
50  
51  
52  
53  
54  
55  
56  
57  
58  
59  
60  
61  
62  
63  
64  
65  
66  
67  
68  
69  
70  
71  
72  
73  
74  
75  
76  
77  
78  
79  
80  
81  
82  
83  
84  
85  
86  
87  
88  
89  
90  
91  
92  
93  
94  
95  
96  
97  
98  
99  
100

## SECTION 2

# OPERATION

### 2.1 CONTROLS AND CONNECTORS

#### 2.1.1 Front Panel

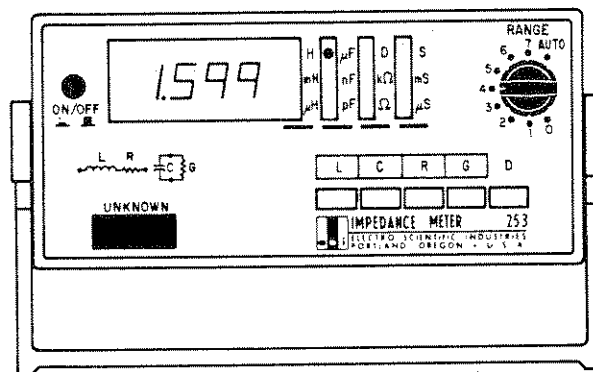

Figure 2-1. Model 253 Front Panel

1. ON/OFF Switch -- A push-on, push-off switch for applying and removing power from the instrument.
2. UNKNOWN Connector -- Terminals designed to be used with KELVIN KLIPS® test leads (ESI Part No. 43072), provided with Model 253, to provide a true four-terminal connection to the unknown or test fixture.

3. L, R, C, and G Pushbuttons -- Function pushbuttons select the type of meter circuit that will measure series inductance (L) and resistance (R) or parallel capacitance (C) and conductance (G).
4. D Pushbutton -- The push-to-read D (dissipation factor) pushbutton displays the D of a capacitor or inductor when the C or L function is selected.
5. Range Switch -- Selects the decimal multiplier and units of measurement for the meter circuit being used. Each range, 0 - 7, can be individually selected or the AUTO position puts the instrument in auto-ranging mode..
6. Display -- A 3-1/2 digit readout for all functions.
7. Units Indicators -- Front panel LED lamps indicate the units of measurement. The basic multipliers and units are: H (henrys), mH (millihenrys),  $\mu$ H (microhenrys), mF (millifarad),  $\mu$ F (microfarad), nF (nanofarad),  $k\Omega$  (kilohms),  $\Omega$  (ohms), S (siemens), mS (millisiemens),  $\mu$ S (microsiemens), and D (dissipation factor).
8. Tiltstand Handle -- Aids portability; tilts instrument for easier viewing of the LED display.

## 2.1.2 Rear Panel

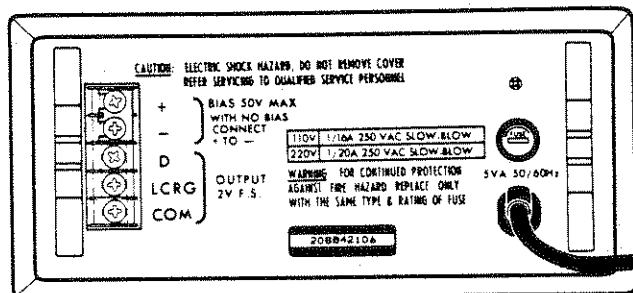

Figure 2-2. Model 253 Rear Panel

1. Bias Terminals -- Allows application of a 0V to 50VDC, 0.1A maximum bias to the capacitor being measured. (The shorting bar must be in place when not using bias feature.) See Section 2.3.6 before using external bias.
2. Output Terminals -- Provides two analog signals proportional to the function selected (L, R, C, or G) and D (for L and C). These terminals can be used with external DVM's (for increased full scale readings or resolution capability), with chart recorders, or with limits comparators, such as the ESI Model 1412B.
3. Fuse -- A 1/16A, 250V, type MDL Slow Blow for 110V line voltage or a 1/20A, 250V, type MDL Slow Blow for 220V line voltage.

## 2.2 OPERATING PROCEDURE

### 2.2.1 Power Requirements

Before turning the power ON, make sure the instrument is set to the proper line voltage. The Model 253 contains an internal slide switch to select the nominal line voltage (see Figure 2-3). In its up position, the switch selects 100 to 125VAC, 50/60Hz operation. In the down position it selects 200 to 250VAC, 50/60Hz operation.



WHEN CHANGING FROM 110VAC OPERATION TO 220VAC OPERATION (OR IN OPPOSITE ORDER), BE SURE TO REPLACE THE REAR PANEL AC FUSE WITH THE PROPER VALUE FOR THE LINE VOLTAGE SELECTED.

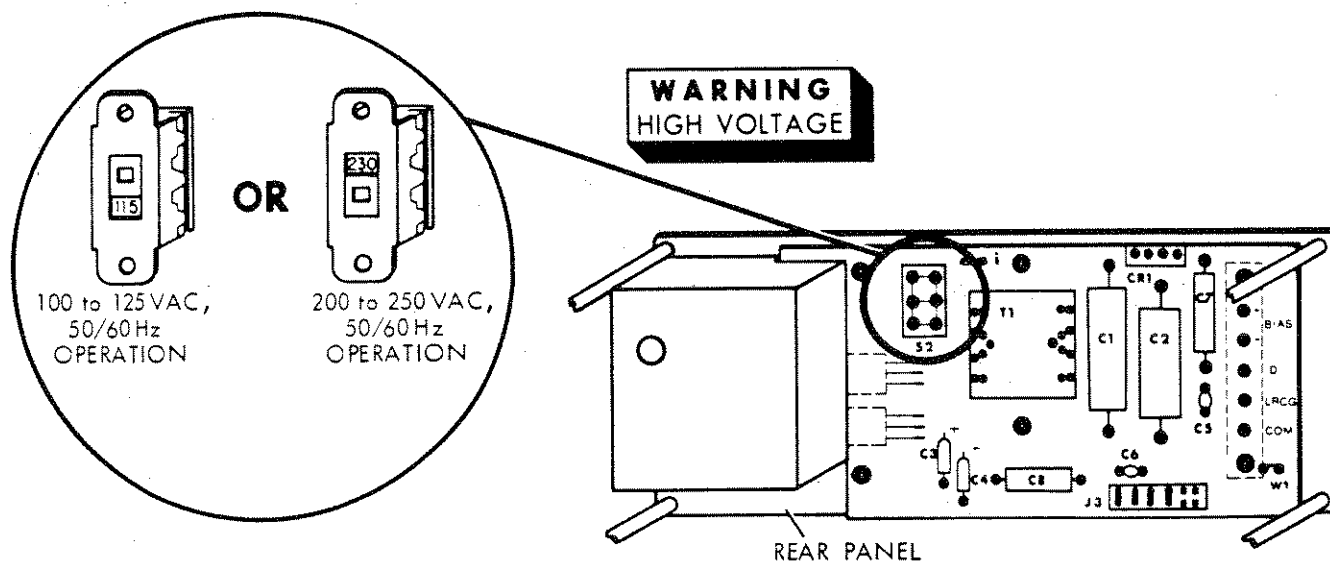

Figure 2-3. Line Voltage Switch

Because of differing power requirements, all instruments shipped outside the United States are without a power cord connector. When placing a connector on the power cord, care must be taken to assure the wires are connected properly. The green or green with yellow stripe wire is always connected to earth ground. The white or light blue wire is connected to the neutral side of the power line. And, the black or brown wire is connected to the high side of the power line.

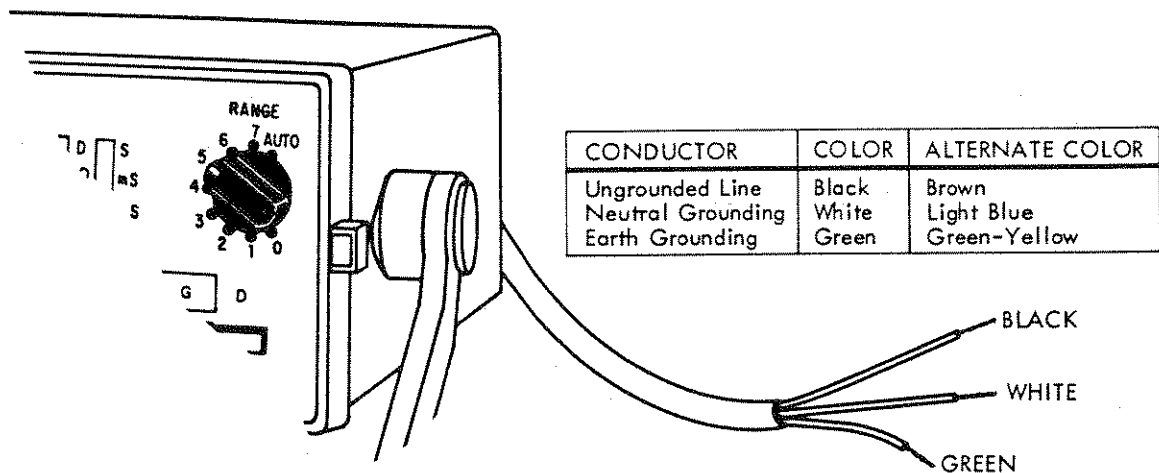

Figure 2-4. Power Cord

### 2.2.2 Applying Power

The push-on, push-off, ON/OFF button in its depressed position applies power to the measurement circuitry. When power is applied, the LED display lights and reads zero when in C and G modes or the display is blank with the decimal point lit in the L and R modes.

### 2.2.3 Connection to Unknowns

The KELVIN KLIP® test lead set (ESI Part No. 43072) is plugged into the 253's front panel UNKNOWN connector. The test leads connector cover is spring-locking and should be squeezed together before inserting or removing.

The test leads provide a shielded, four-terminal connection to the unknown (see Figure 2-5a). The clip with the red hinge-spool provides the HI DRIVE and HI SENSE connections to the unknown and the clip with the black hinge-spool make the LO DRIVE and LO SENSE connections.

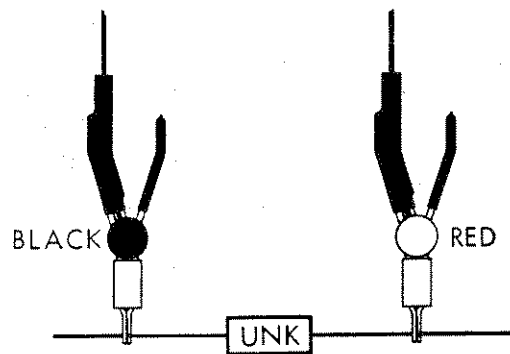
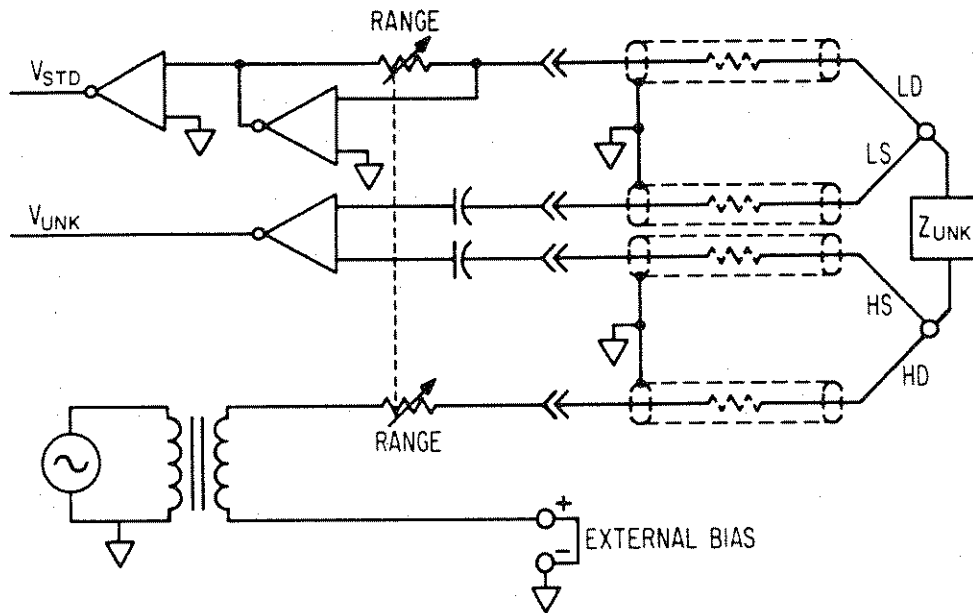

Figure 2-5a.



For connection to three terminal unknowns (the third connection is to ground), a ground wire must be added to the test lead set. This wire is connected as in Figure 2-5b.

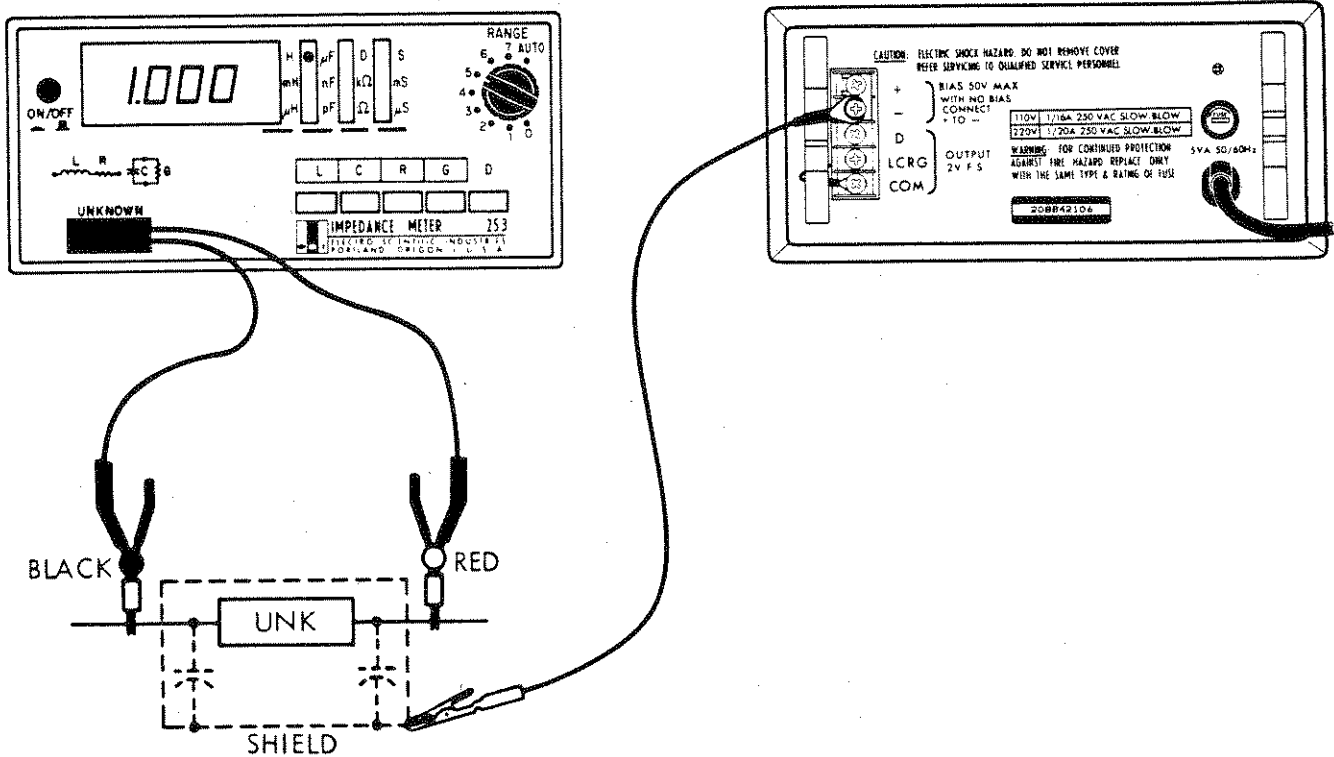

Figure 2-5b

### 2.2.3.1 Test Fixture Compensation

The Model 253 uses a 3.3pF capacitor (C6 in Figure 2-6) to compensate for the capacitance of the test leads. If the 253 is used with a test fixture, the larger capacitance of the fixture must also be compensated for. There are two methods for compensating this larger capacitance. The first method is to make a zero capacitance measurement with the test fixture connected. This reading is mentally subtracted from all other measurements.

The second method for compensating the larger capacitance is to change the value of C6 from 3.3pF to 10pF and to add an external trim capacitor. The external trim capacitor is connected in parallel with the unknown and should be of such a value that the test fixture capacitance can be trimmed to zero. Typically, the maximum value of this trim capacitor is 15pF. The trim capacitor can either be added to the test cable, between Terminals 1 and 3 of the connector as shown in Figure 2-6, or it can be added to the test fixture.

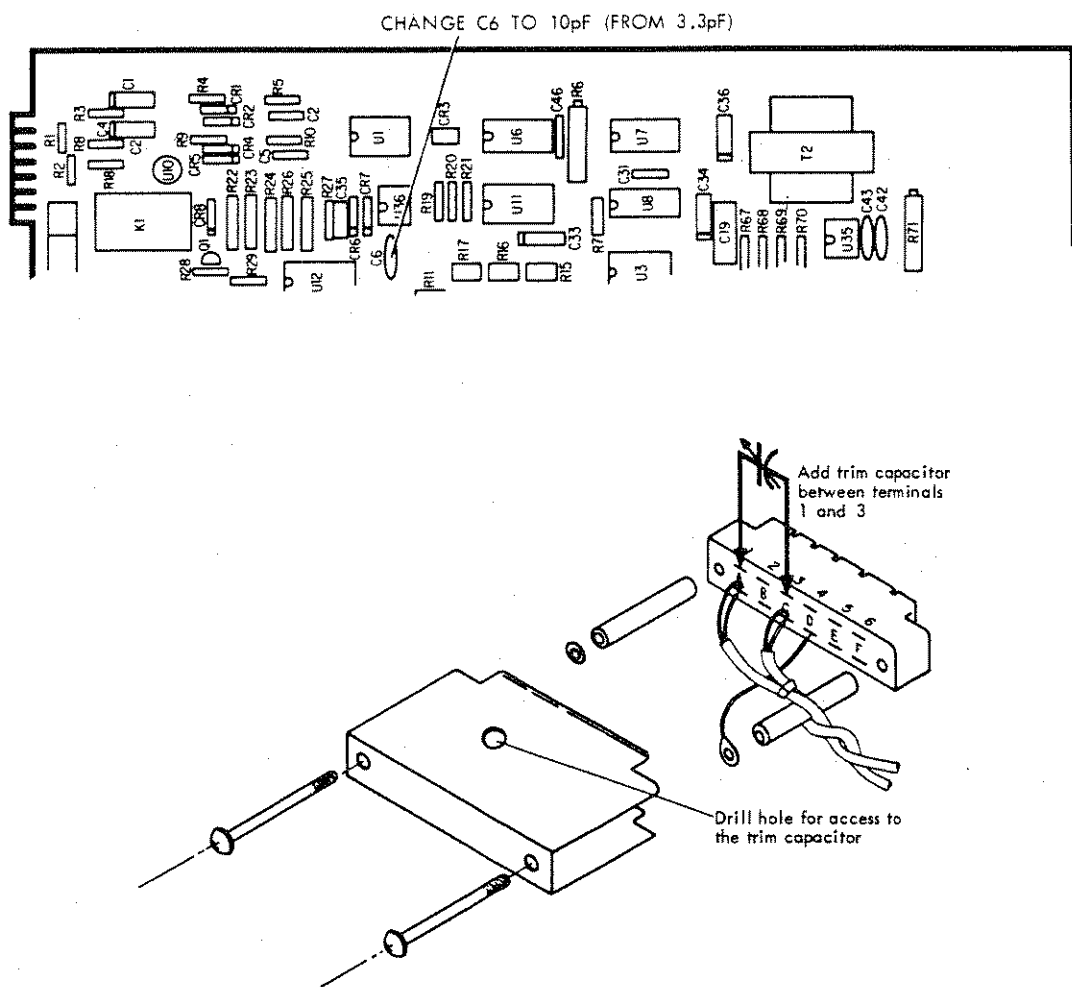
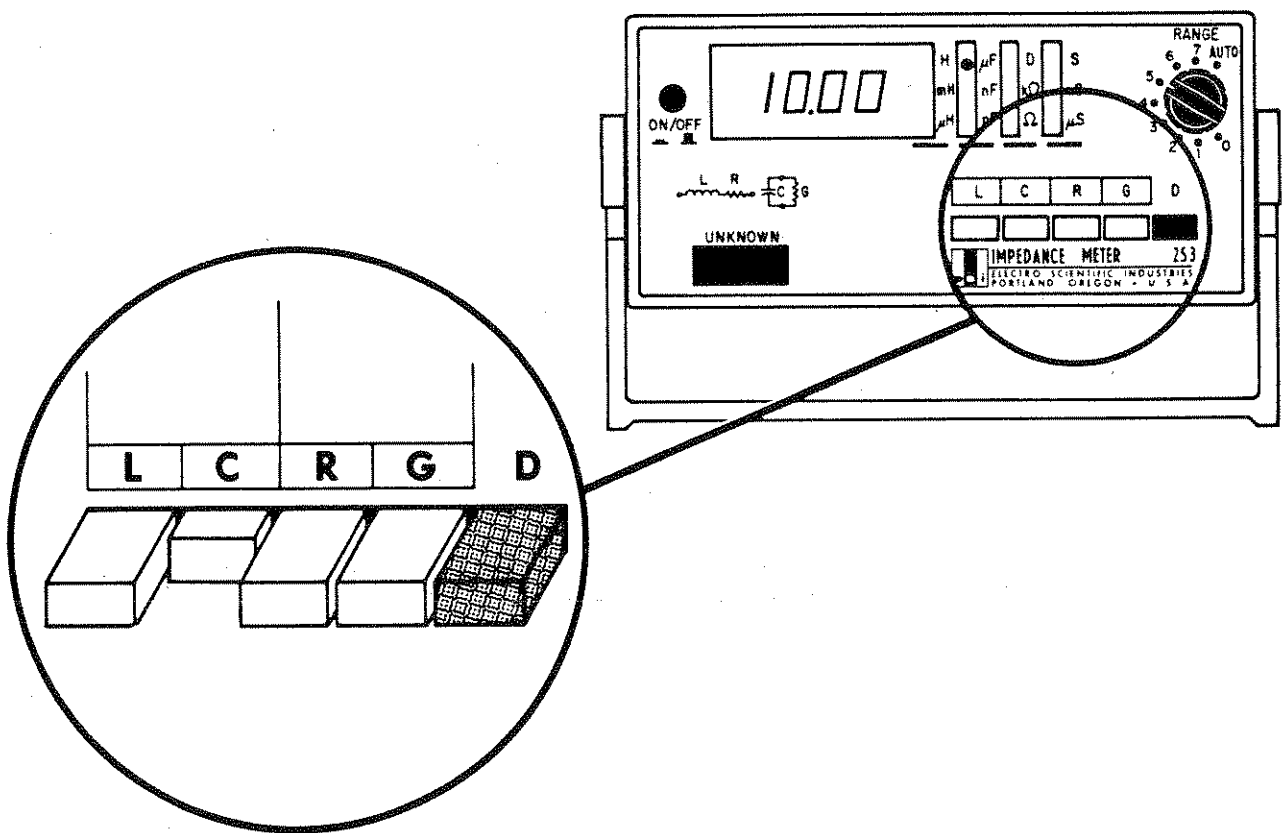

Figure 2-6. Test Fixture Compensation

## 2.2.4 Function Selection

Model 253 is designed to measure series inductance (L), parallel capacitance (C), series resistance (R), parallel conductance (G), and dissipation factor (D) of inductance and capacitance. One of these measurement modes is selected by depressing the proper front panel button. (If all buttons are in their out position, the instrument reverts to the inductance measurement mode.)

Example: Select the capacitance measurement function. (Depress the C pushbutton.)



Example: Select the conductance measurement function. (Depress the G pushbutton.)

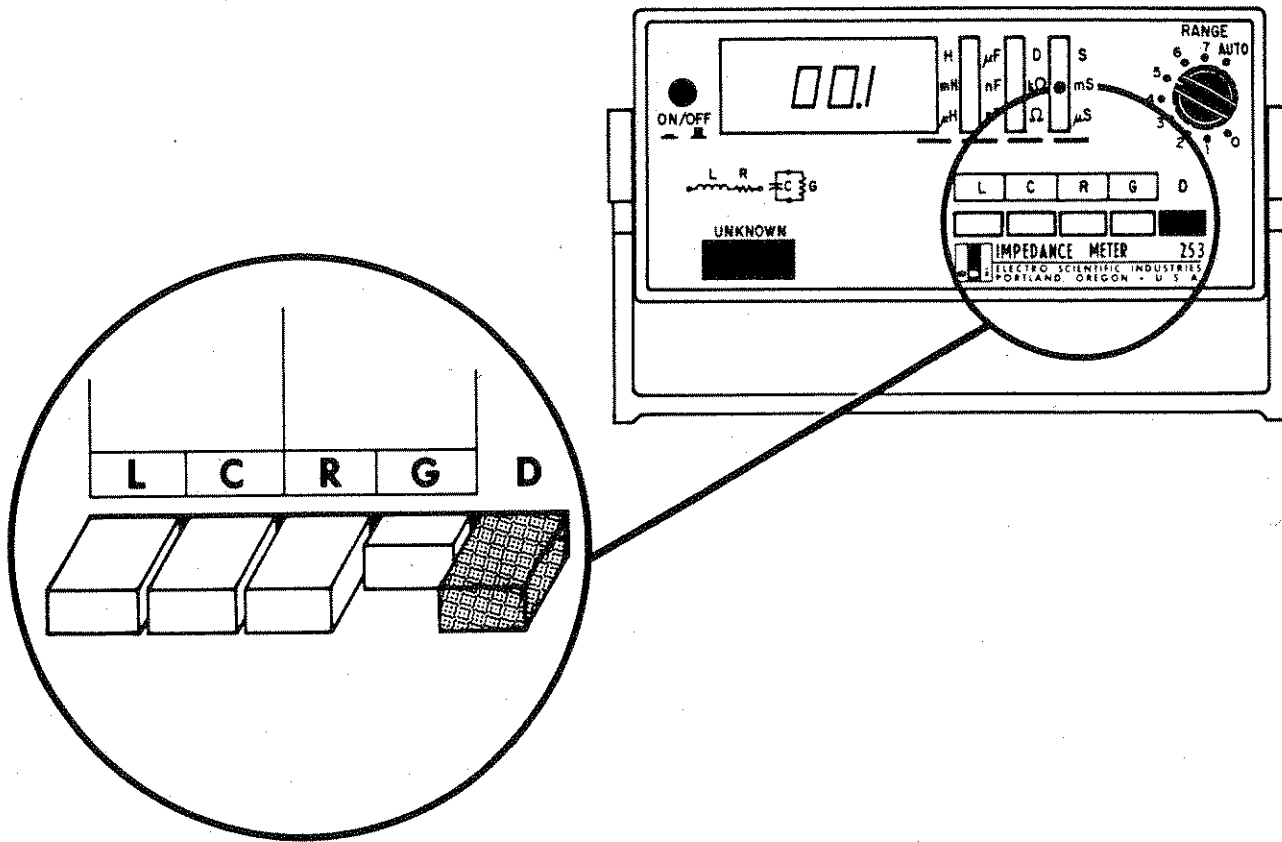

If a negative sign appears on the display when measuring an unknown, possible causes are:

- "C" button has been pushed when measuring an inductor.
- "L" button has been pushed when measuring a capacitor.
- The unknown is more capacitive (or inductive) than suspected. For example, an inductor that resonates below 1kHz will measure as though it were a capacitor.
- A diode requires bias voltage (a negative reading may appear if bias voltage is not applied).

To measure the dissipation factor (D) of a capacitor or inductor, push and hold the D button while the C or L function is selected. (The display will blank if D is pushed, while the unit is in R or G mode and the unknown is resistive.)

When measuring the conductance (G) of a capacitor or the resistance (R) of an inductor, the R or G reading may be quite small. In trying to acquire more resolution by moving the range switch to the next lower range, the display will, usually blank, indicating overload. Blanking occurs because the instrument is still monitoring the reactive component (L or C) in addition to measuring and displaying the loss component (R or G). In moving to the next lower range, the reactive component becomes too large for the lower range causing overload and a blanked display.

Example: While measuring a  $0.82\mu\text{F}$  capacitor using the  $2\mu\text{F}$  range, the 253 display reads:

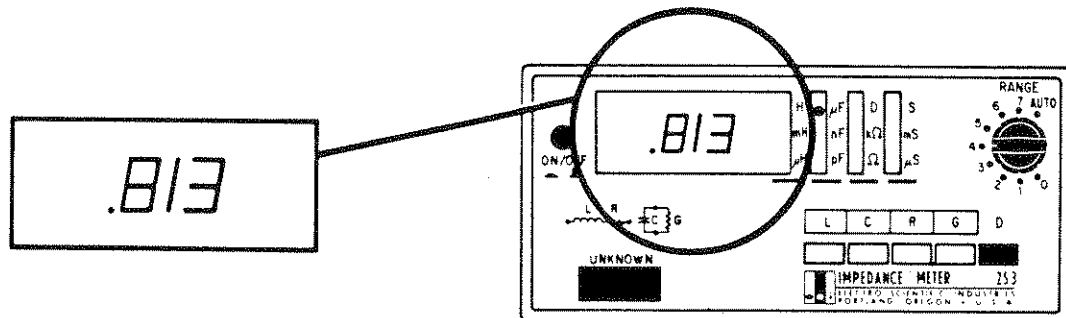

Switching to the conductance (G) mode, the display may read:

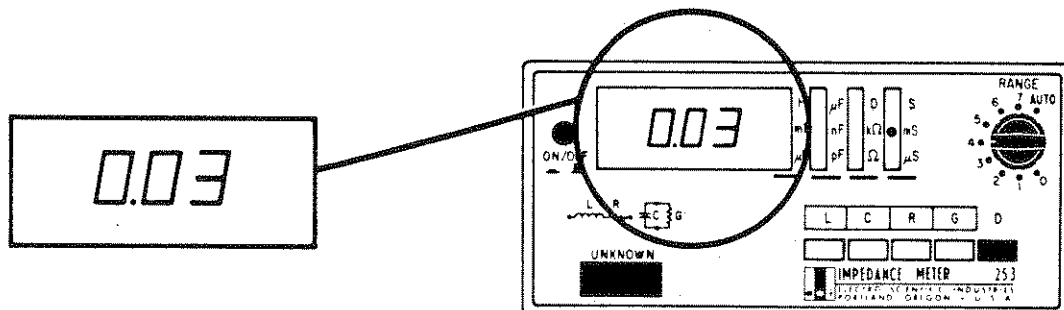

Trying further to investigate this reading, you down range from the 20mS range to the 2000µS range. The display blanks:

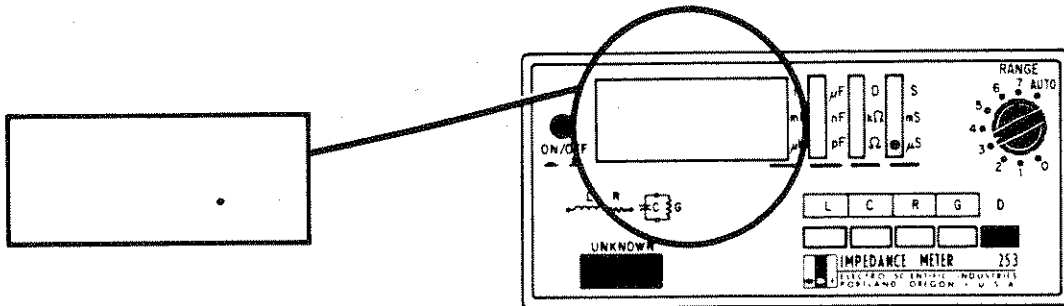

The display blanks because, while ranging from 20mS to 2000µS, the capacitance range changed from 2µF to 200nF. Since 0.82µF is too large to measure on the 200nF range, an overload occurs and the display blanks.

### 2.2.5 Range Selection

Measurement ranges are selected either manually or automatically via a nine-position rotary switch. Switch positions 0 - 7 manually select the corresponding range (See Figure 2-7). For maximum accuracy, select the range that gives the largest on-scale reading. The AUTO position automatically selects the lowest corresponding range to give the highest resolution display.

		Ranges							
		0	1	2	3	4	5	6	7
Full Scale Values	L <sub>s</sub>	200 µH	2 mH	20 mH	200 mH	2 H	20 H	200 H	200 H
	C <sub>p</sub>	200 pF	2 nF	20 nF	200 nF	2 µF	20 µF	200 µF	2000 µF
	R <sub>s</sub>	2 Ω	20 Ω	200 Ω	2000 Ω	20 kΩ	200 kΩ	2000 kΩ	2000 kΩ
	G <sub>p</sub>	2 µS	20 µS	200 µS	2000 µS	20 mS	200 mS	2000 mS	20 S
	D	1.999							

Figure 2-7. Range Chart

Autoranging operates for the major component of the unknown i.e., C for capacitors, L for inductors, R for resistors. When measuring the minor component of the unknown, i.e. R of inductors, G of capacitors, use manual ranging.

The units of the displayed reading, i.e.  $\mu\text{H}$ ,  $\text{mH}$ ,  $\text{H}$ , etc., are indicated by front panel LED lamps. If either the reactive or resistive value of the unknown exceeds the range selected, the display will blank.

Example: Set the instrument to measure  $100\text{pF}$  capacitors.

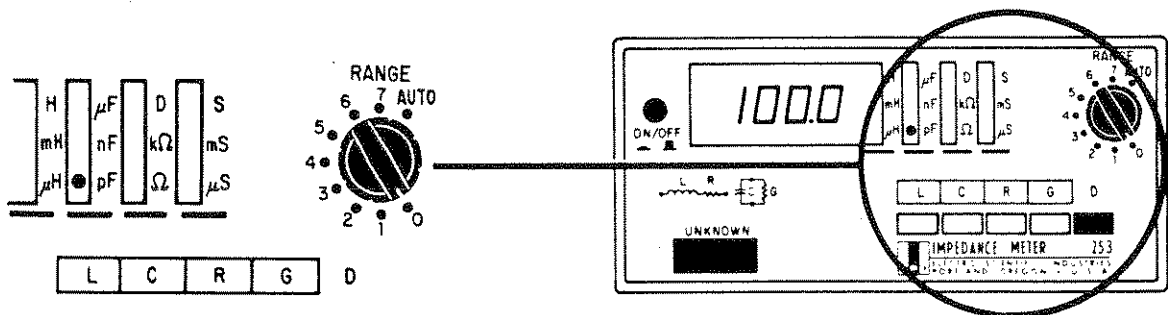

Example: Set the instrument to measure  $100\text{k}\Omega$  resistors.

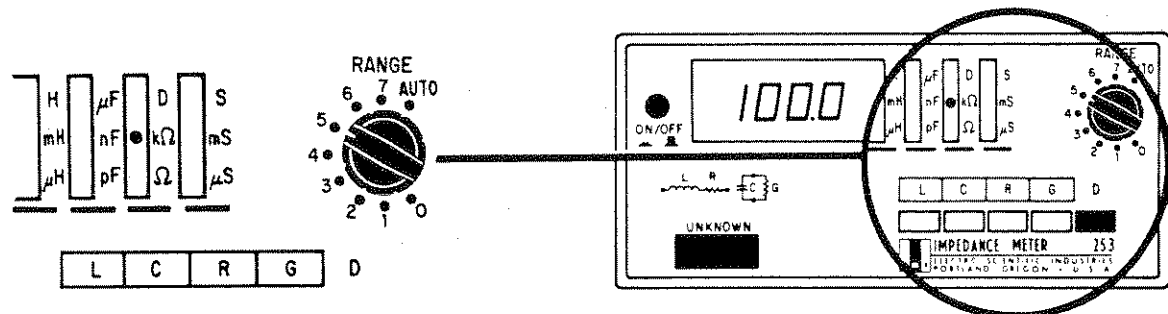

If the value of a component is not known, set the instrument to its highest range before connecting the test leads. Step the instrument down one range at a time until the range with the highest resolution is reached. If the display is blank after the component is connected, the value of the component is too large to measure directly, see Section 2.3 for alternate measurement techniques.

## 2.2.6 Summary of Operation

Press the appropriate function button (L, C, R, or G) and connect the KELVIN KLIPS\* to the unknown. For maximum accuracy, select the range that gives the largest on-scale reading. When the RANGE switch is in AUTO position, the instrument automatically selects the lowest corresponding range to give the highest resolution display. The measurement is displayed after one second or less. Repetitive measurements are made at the rate of four per second. The range LED lamps indicate the readout units (i.e.  $\mu\text{H}$ ,  $\text{mH}$ ,  $\text{H}$ , etc.). If the value of the unknown exceeds the range selected, the display will remain blanked. To measure the dissipation factor of a capacitor or inductor, push and hold the D button while the C or L function is selected.



## 2.3 MEASUREMENT TECHNIQUES

### 2.3.1 Resistance Measurements at 1kHz

When using the resistance function, the maximum measurement is 1999k $\Omega$ . For measurements from 1999k $\Omega$  to 1000M $\Omega$ , use the G (conductance) function where  $G=1/R$  or  $R=1/G$ . Measurement accuracy is determined by  $\pm(0.25\% + 1 \text{ digit})$  where 1 digit will be  $\pm 100\%$  at 1000M $\Omega$ ,  $\pm 10\%$  at 100M $\Omega$ , and  $\pm 1\%$  at 10M $\Omega$ .

High-value, bobbin-type, wire-wound resistors have shunt capacitance which may affect measurements by appearing as " $-L_s$ ". This causes some difference between AC and DC resistance measurement values.

The resistive component ( $R_s$ ) of inductors and transformers, when measured at 1kHz, will differ from the DC winding resistance. If the core material is air or low loss (e.g. powdered permalloy), the AC and DC values will be nearly equal. For laminated magnetic cores, the AC resistance will be greater than the winding resistance (sometimes much greater). This is caused by the core losses which change both with frequency and test current level.

### 2.3.2 Capacitance Measurements

Shielded devices. For shielded devices, the shield should be connected to the rear panel -Bias terminal to provide proper guarding.

Most two- and four-terminal cables or sorting fixtures are not guarded immediately adjacent to where the unknown capacitor is connected, and a zero capacitance reading can change by a few picofarads whenever the ends of the cable or fixture terminals are physically moved. Always maintain the physical orientation of the leads or terminals after checking for zero capacitance. Subtract zero-capacitance reading from the capacitance reading for the unknown.

**Equivalent Series Resistance (ESR).** To measure series resistance of capacitors, use the Rs function. Series resistance will be displayed on the front panel.

**Series Capacitance.** The Ls function can be used to measure series capacitance. (The capacitor is measured with a constant current rather than a constant voltage.) A negative reading will be shown, and the following equation must be used to convert the "-Ls" readings to the "Cs" values:

$$C_s = \frac{1}{(2\pi f)^2 (L_s)}$$

Where: f = frequency in hertz  
Cs = series capacitance in farads  
Ls = series inductance in henrys (ignore sign)

**Dissipation factor (D).** The D of large value electrolytic capacitors can be determined using the Ls and Rs functions (using the same range). The following equation converts the Rs and Ls, in counts (ignore the sign and decimal point), to D values:

$$D = 1.59 \times \left( \frac{R_s}{L_s} \right) \text{ for } 100\text{Hz and } 1\text{kHz operation}$$

$$D = 1.33 \times \left( \frac{R_s}{L_s} \right) \text{ for } 120\text{Hz operation}$$

Where: D = dissipation factor  
Rs = equivalent series resistance reading in counts  
Ls = series inductance in counts

**Parallel Capacitance Measurements.** The relation between parallel and series capacitance measurements is:

$$C_s = (1 + D^2) C_p \text{ where } D = G_p / 2\pi f C_p$$

The following graph illustrates the relation between  $C_s$  and  $C_p$ . The graph is used to obtain a  $C_s$  value for a capacitor by measuring the  $C_p$  and  $D$  values of the capacitor. To locate the  $C_s$  value, find the measured  $D$  value along the horizontal axis of the graph. (The  $D$  reading from the Model 253 will be a Dissipation Factor value not a Percent Dissipation value.) Move up the graph to the B curve and read the corresponding value on the righthand vertical axis. Multiply the measured  $C_p$  value by this reading to obtain the desired  $C_s$  value.

The A curve on the graph is used with the lefthand vertical axis in the same manner as described above. The A curve and lefthand scale provide the Percent Difference between  $C_s$  and  $C_p$ .

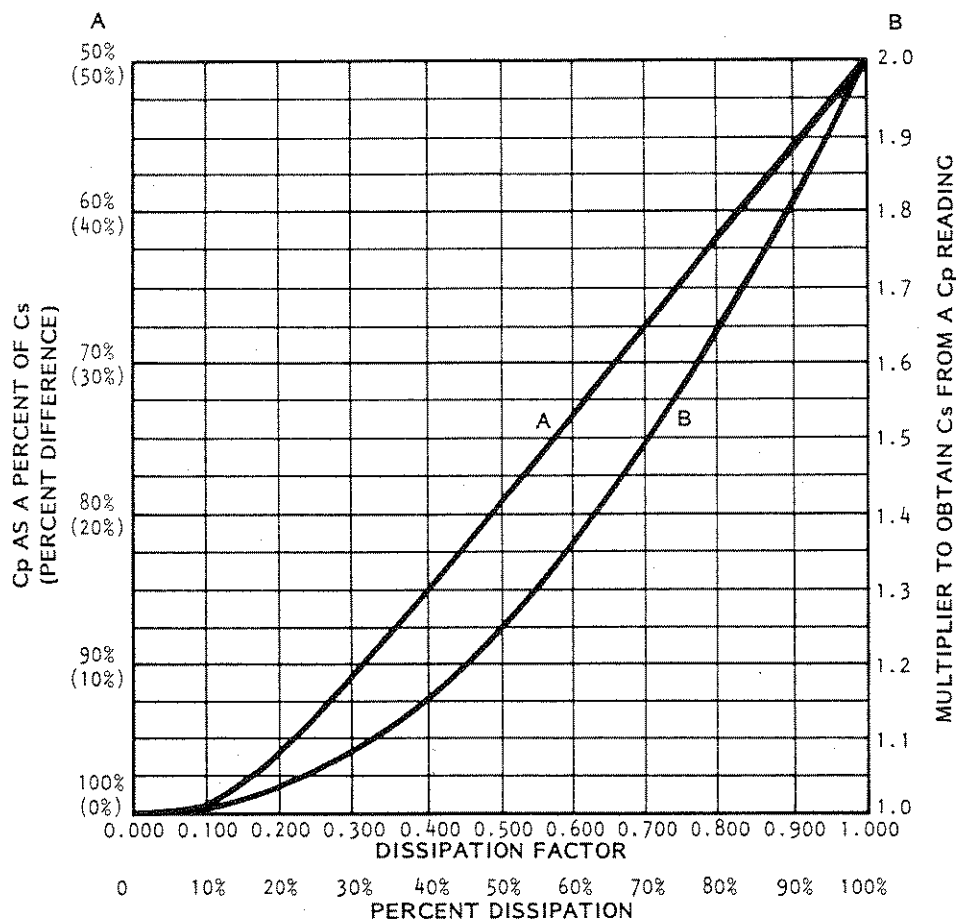

### 2.3.3 Inductance Measurements

The 253 measures the total impedance connected to its terminals. Both the unknown inductor and its leads contribute to this impedance. The leads have some resistance and inductance which affect the value read from the meter.

In making high inductance measurements, avoid AC pickup and keep the stray capacitance to a minimum. To minimize both effects, keep hands as far as possible from the inductor being measured. Keep the leads as short and direct as possible. Take care to avoid coupling stray magnetic fields into the inductor.

For greatest accuracy on low inductance measurements, minimize the lead impedance. Closely spaced, twisted leads will reduce the inductance and pickup of stray fields. The KELVIN KLIPS® Cable Assembly will add about  $0.5\mu\text{H}$  to  $L_s$  and  $0\text{m}\Omega$  to  $R_s$ . Short the test leads together and subtract the reading from the unknown inductance measured.

Measuring leakage inductance of transformer windings is an easy task for the Model 253 since there are no "false nulls" as found in manually-balanced bridges.

### 2.3.4 Determining Quality Factor (Q) of Inductors

To determine the Q of inductors, push the D button, record the D reading and calculate Q from the equation  $Q=1/D$ . This procedure works well for  $Q \geq 0.5$  (or  $D \leq 2$ ). For  $Q < 0.5$ , measure the inductance of the unknown and record the readout display in digits only. With the RANGE switch in the same position, press the R button and note the readout display in digits, only. Do not record the decimal point or range multiplier for  $L_s$  or  $R_s$ ; they are not required. Turn to Figure 2-8 for the D-Q nomograph. Use a straightedge to line up the  $L_s$  digits recorded (left-hand scale) with the  $R_s$  digits recorded (right-hand scale). Q is taken from the left-hand side of the center scale where the straightedge crosses. For example, with an  $L_s$  digital display of "300" and an  $R_s$  digital display of "600", Q is 0.3. Accuracy of Q is primarily limited by interpolation of the nomograph.

Although the nomograph provides a convenient way to approximate Q, it may be determined more accurately by the formula:

$$Q = 0.628 \times \left( \frac{L_s}{R_s} \right) \text{ for } 100\text{Hz and } 1\text{kHz operation}$$

$$Q = 0.754 \times \left( \frac{L_s}{R_s} \right) \text{ for } 120\text{Hz operation}$$

Where: Q = quality factor  
Rs = equivalent series resistance reading in counts  
Ls = series inductance in counts

See Table 1-1 for accuracy of  $L_s$  and  $R_s$  measurements.

### 2.3.5 Determining Dissipation Factor (D) of Capacitors Using Nomograph

Model 253 will measure dissipation factor up to 1.999. For D values greater than 2 the nomograph should be used. Measure the capacitance of the unknown and record the readout display in digits only; do not record the decimal point. With the RANGE switch left in the same position, push the G button and note the readout display in digits only; do not record the decimal point. Turn to Figure 2-8 for the D-Q nomograph. Use a straightedge to line up the Cp digits recorded (left-hand scale) with the Gp digits recorded (right-hand scale). D is taken from the right-hand side of the center scale where the straightedge crosses. For example, with a Cp digital display of "200" and a Gp digital display of "300", D is 2.3. Accuracy of D is primarily limited by interpolation of the nomograph.

Dissipation factor may be determined more accurately by the formula:

$$D = 1.59 \times \left( \frac{G_p}{C_p} \right) \text{ for } 100\text{Hz and } 1\text{kHz operation}$$

$$D = 1.33 \times \left( \frac{G_p}{C_p} \right) \text{ for } 120\text{Hz operation}$$

Where: D = dissipation factor

Gp = parallel conductance reading in counts

Cp = parallel capacitance in counts

See Table 1-1 for accuracy of Cp and Gp measurements.

Electrolytic capacitors with high dissipation are usually unstable and the measured values may drift.

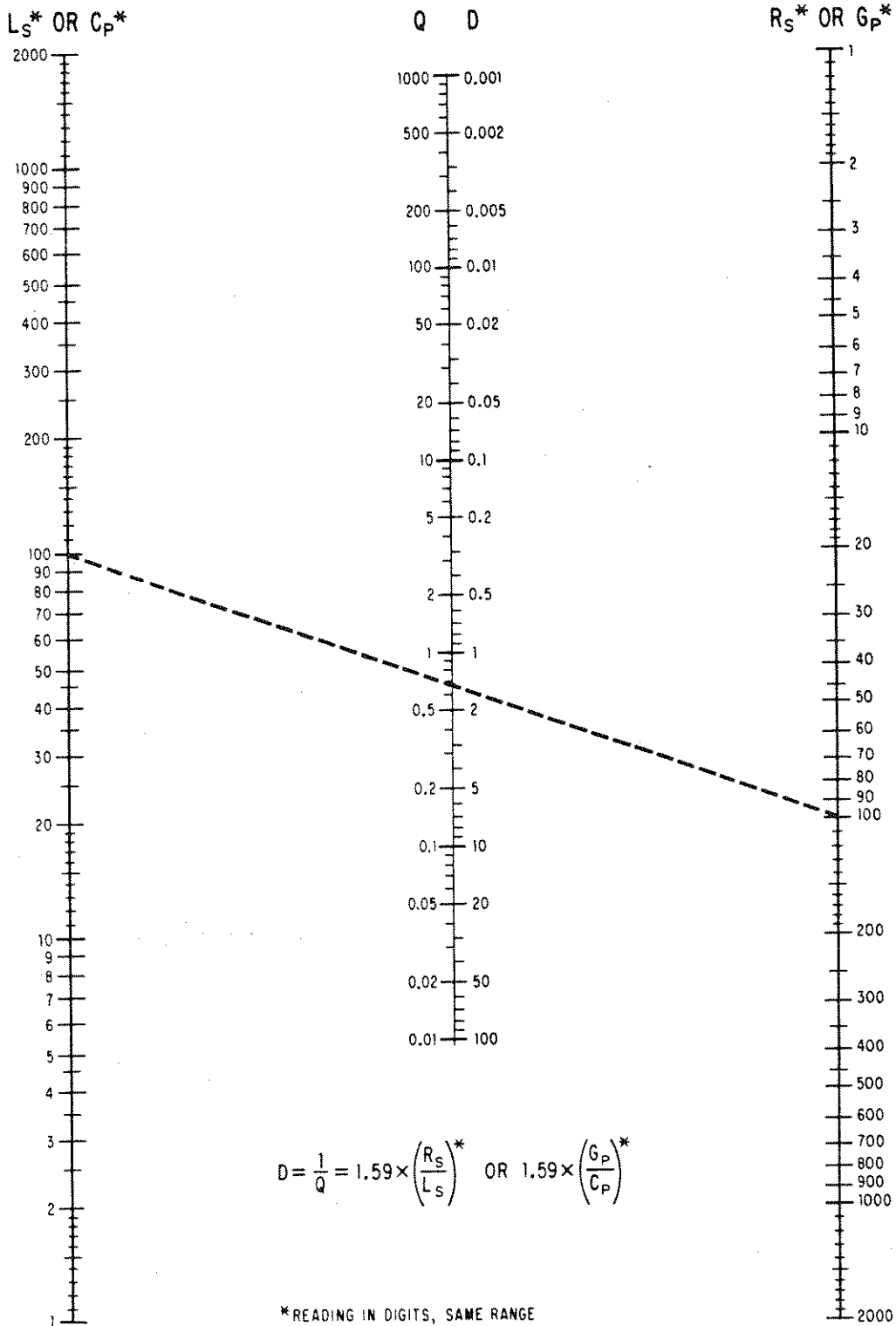

Figure 2-8. Model 253 D-Q Nomograph

### 2.3.6 Using the Bias Feature

**WARNING**

**TO AVOID PERSONAL INJURY FROM ELECTRICAL SHOCK OBSERVE SAFETY PROCEDURES AS NEEDED FOR THE BIAS VOLTAGE APPLIED.**

Bias voltage is necessary or desirable when measuring the capacitance of diodes or of some electrolytic or tantalum capacitors.

There is a provision on the rear panel for connecting an external bias source of zero to 50VDC. Remove the shorting link between BIAS terminals when using this feature.

If the external bias supply is not a low AC impedance type, it should have a capacitor bypass of five times the range full-scale value connected across the bias terminals. The bias supply should be current limited to 0.1A maximum.

With no bias supply connected, the rear-panel + and - terminals must be strapped together.

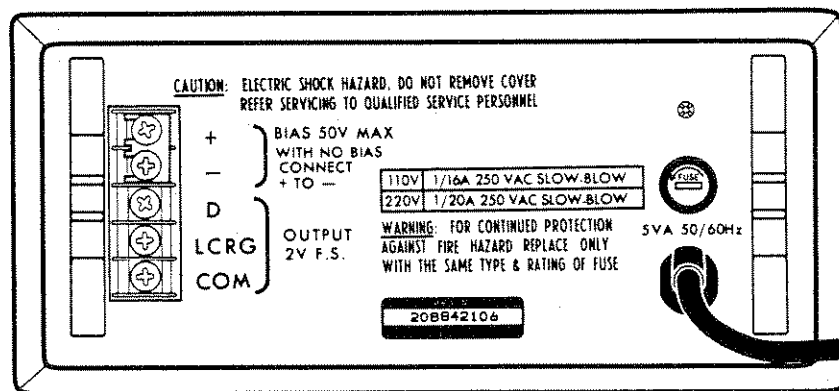

Figure 2-9. Rear Panel



### 2.3.7 Signal Output Terminals

Terminals are provided on the Model 253's rear panel for connecting external devices: digital voltmeters to increase full-scale resolution or simultaneous D reading; chart recorders to evaluate unknowns with changing impedances; limits comparators (ESI Model 1412B) for HI, LO, GO, and HI D component sorting.

The analog output signals are proportional to the function selected (L, C, R, or G) and D (for L and C only). Specifications for these signals are:

Scale Factor	1V per 1000 counts
Source Resistance	1000Ω
Accuracy	±(0.25% of reading + 1mV)

### 2.3.8 Measuring Grounded Unknowns

The Model 253 is designed to measure ungrounded components. However, with a minor modification, it can be used to measure impedances that are connected directly or tightly coupled to earth ground.

This first procedure outlines the modification of all instruments with serial numbers 928999 and smaller.

1. Remove all instrument power.
2. Remove instrument cover by unscrewing the two cover screws and sliding the cover off.

**WARNING**

TO AVOID PERSONAL INJURY FROM ELECTRIC SHOCK DO NOT REMOVE INSTRUMENT COVERS OR PERFORM ANY MAINTENANCE OTHER THAN DESCRIBED IN THIS MANUAL. INSTALLATION AND MAINTENANCE PROCEDURES DESCRIBED IN THIS MANUAL ARE TO BE PERFORMED BY QUALIFIED SERVICE PERSONNEL ONLY.

A small zero offset may become apparent during low value grounded capacitance measurements. This offset can be corrected by making a reading with the unknown connected only to the red clips and subtracting it from the final measured capacitance.

To return to normal ungrounded measurements reverse the above procedures.

### 2.3.9 Measuring Battery Impedance

Current producing capabilities of a battery can be determined by using the 253 to measure its impedance. Series resistance and series capacitance measurements can be made on batteries with voltages up to 50V. To measure series resistance:

1. Set the 253 to measure  $R_s$  and to the highest measurement range.
2. Remove the shorting bar from the + and - bias terminals. The bias terminals are located on the instrument's rear panel terminal strip.
3. Connect a  $500\mu\text{F}$  (or larger) capacitor, whose working voltage is greater than the rated voltage of the battery, to the bias terminals (see Figure 2-14). Observe correct polarity when connecting the capacitor.
4. Connect the test leads with the red hinge-spool to the positive battery terminal and the lead with the black hinge-spool to the negative terminal (see Figure 2-14).

5. Move the range switch to the range with the highest resolution displayed (see Section 2.2.5) unless that range uses excessive test current for the size of battery being measured. See Table 1-1 for range test currents.

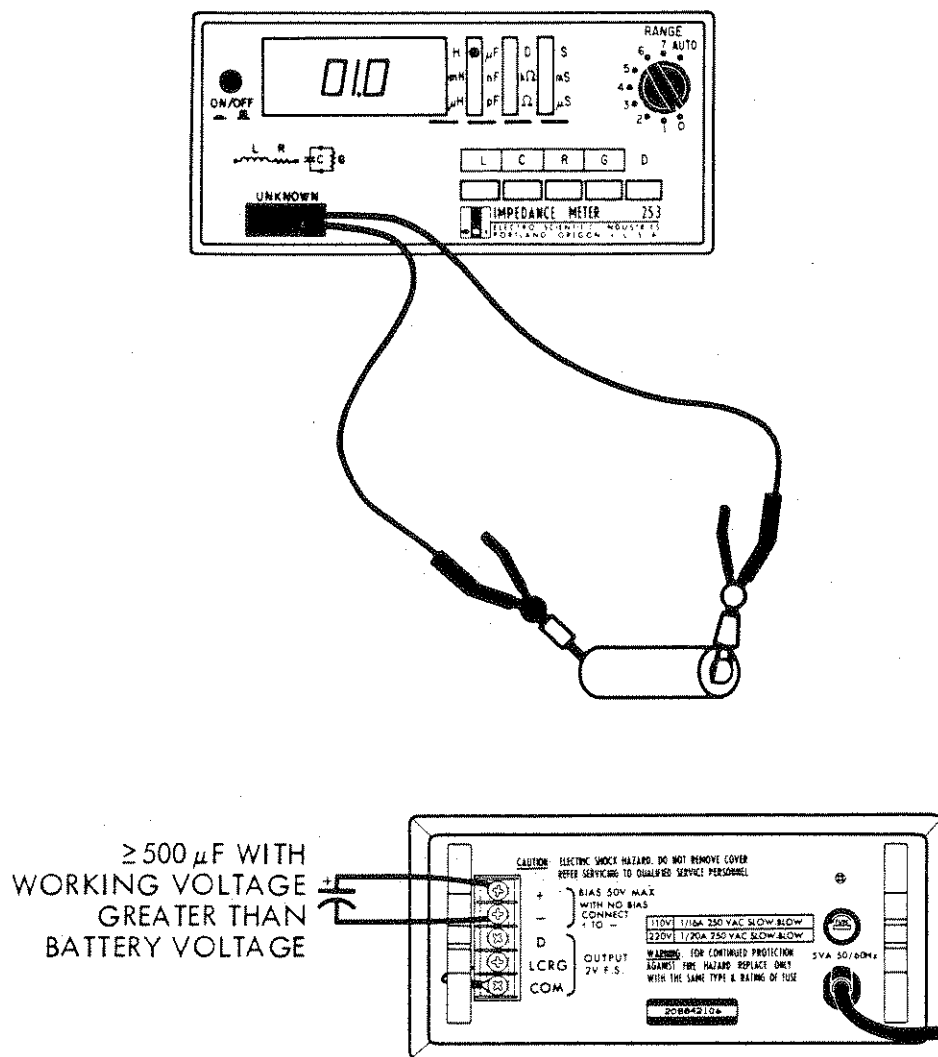

Figure 2-14. Measuring Battery Impedance

The Ls function must be used to measure the series capacitance of a battery. Instrument set up is the same as for Rs measurements (Figure 2-14). A negative reading will be shown, and the following equation must be used to convert the "-Ls" reading to "+Cs" values:

$$Cs = \frac{1}{(2\pi f)^2 (-Ls)}$$

Where: f = frequency in hertz

Cs = series capacitance in farads

Ls = series inductance in henrys

Care must be taken so the measurement current level of the 253's internal source does not exceed the rating of the battery being tested. See Table 1-1 for range test currents.

### 2.3.10 Component Sorting

Model 253, when used with ESI Model 1412B Limits Comparator, sorts components according to percent deviation and dissipation factor, simultaneously. Component sorting can be manual or automatic; Model 1412B provides four contact closures for operating automatic component handling equipment.

Model 1412B front panel controls set upper and lower limits around a nominal value (L, R, C, or G), with either of two full scale ranges -- 10% or 100%. An upper limit for dissipation factor (D) is also set by a front panel control. Test results are shown by four front panel LEDs. They indicate:

GO indicates value between - and + % limits and less than D limit.

LO indicates value less than - % limit.

HI indicates value greater than + % limit.

D HI indicates dissipation factor greater than limit.

Connect the 253 and 1412B as shown in Figure 2-15.

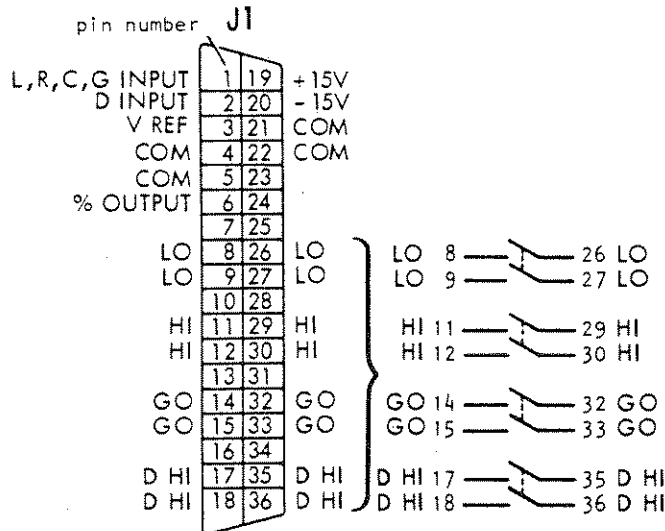
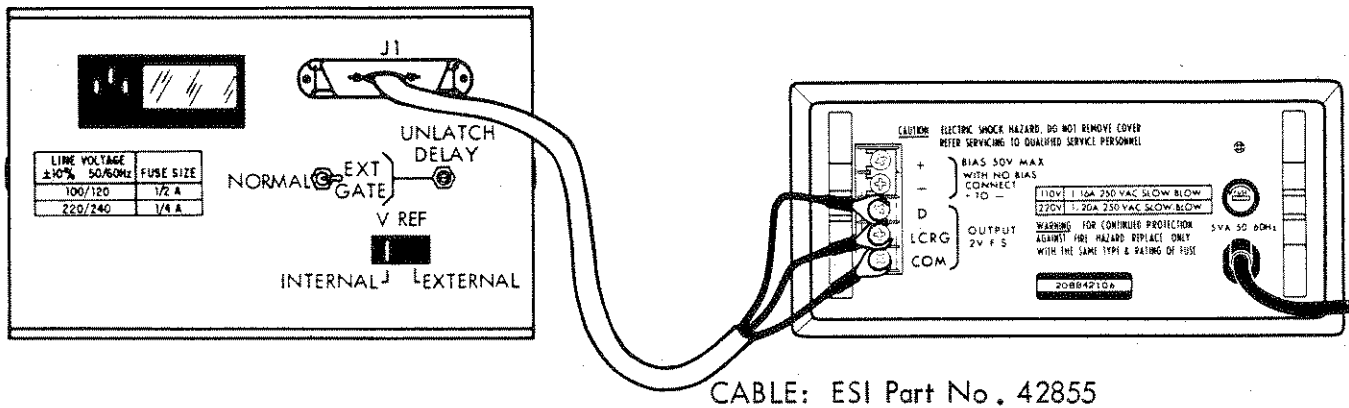

NOTE: For resistive unknowns connect the D lead to the COM terminal

Figure 2-15. Model 253 and Model 1412B Interconnection

## Operation

The following instructions assume Model 253 and Model 1412B are connected and both are turned on.

Model 253 setup: (for capacitor sorting)

1. Push the C button on the Model 253 front panel.
2. Set the range switch to give maximum resolution on the display.

Model 1412B setup:

1. Set the rear panel V REF switch to INTERNAL.
2. Set NOMINAL VALUE switches to anticipated value.
3. Set LIMITS FULL SCALE toggle switches, and % LIMITS and D LIMIT dials to desired limits.

The measurement:

Connect unknown to the Model 253. If the unknown is within the set limits, the GO LED will light. If it is not within limits, the appropriate indicator will light.

Example: Sort 15 $\mu$ F capacitors within +25%, -15% limits with a maximum dissipation limit of 0.0250. Instrument set up is as follows:

Model 253:

Function and Range settings

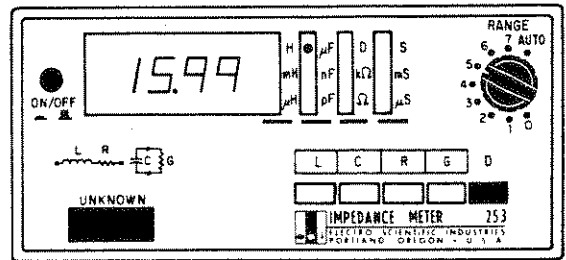

Model 1412B:

Nominal value setting

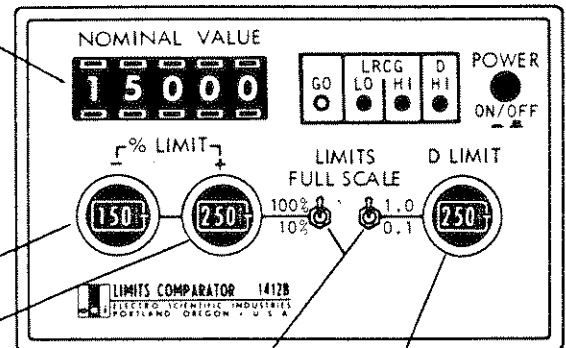

- % Limits setting

+ % Limits setting

LIMITS FULL SCALE Toggle switches settings

D Limit setting

Connect the unknown and observe indicator lights. If the LO LED is lit, the unknown is lower than the lower % limit. Similarly, if the HI LED is lit, the unknown is a larger value than the upper % limit. If the D HI LED is lit, the dissipation factor of the unknown exceeds the set limit. If the GO indicator is lit, the unknown value is within the desired limits; in the example, 15 $\mu$ F, +25%, -15%, with a dissipation factor less than 0.0250.

For further operating instructions, see the Model 1412B instruction manual.



## SECTION 3

# CIRCUIT DESCRIPTIONS

### 3.1 GENERAL DESCRIPTION

When measuring  $C_p$  or  $G_p$ , a voltage is applied across the unknown and range resistor in Figure 3-1. The voltage across the unknown is held constant to within one part in several thousand by the 1kHz oscillator feedback control circuit. A current proportional to the value of the unknown impedance is produced through the range resistor. The resultant voltage drop across the range resistor is separated into two vector components by the Phase Sensitive Detectors (PSD) and Reference Voltage Generator (RVG). Receiving gating signals from RVG, the PSD will measure  $G_p$ , the component in phase ( $0^\circ$ ) with RVG, and  $C_p$ , the component at quadrature ( $90^\circ$ ). The selected detector output is then fed to the A/D Converter which has a readout of 1000 counts/volt.

When measuring  $L_s$  or  $R_s$ , a voltage is applied across the unknown and range resistor in Figure 3-1. The voltage across the range resistor is held constant to within one part in several thousand by the 1kHz oscillator feedback control circuit. With a constant current flowing through the unknown, a voltage proportional to the value of the unknown impedance is developed across the unknown. The resultant voltage drop is separated into two vector components by the Phase Sensitive Detector (PSD) and Reference Voltage Generator (RVG). Receiving gating signals from the RVG, the PSD will measure  $R_s$ , the component in phase ( $0^\circ$ ) with the RVG, and  $L_s$ , the component at quadrature ( $90^\circ$ ). The selected detector output is then fed to the A/D Converter which has a readout of 1000 counts/volt.

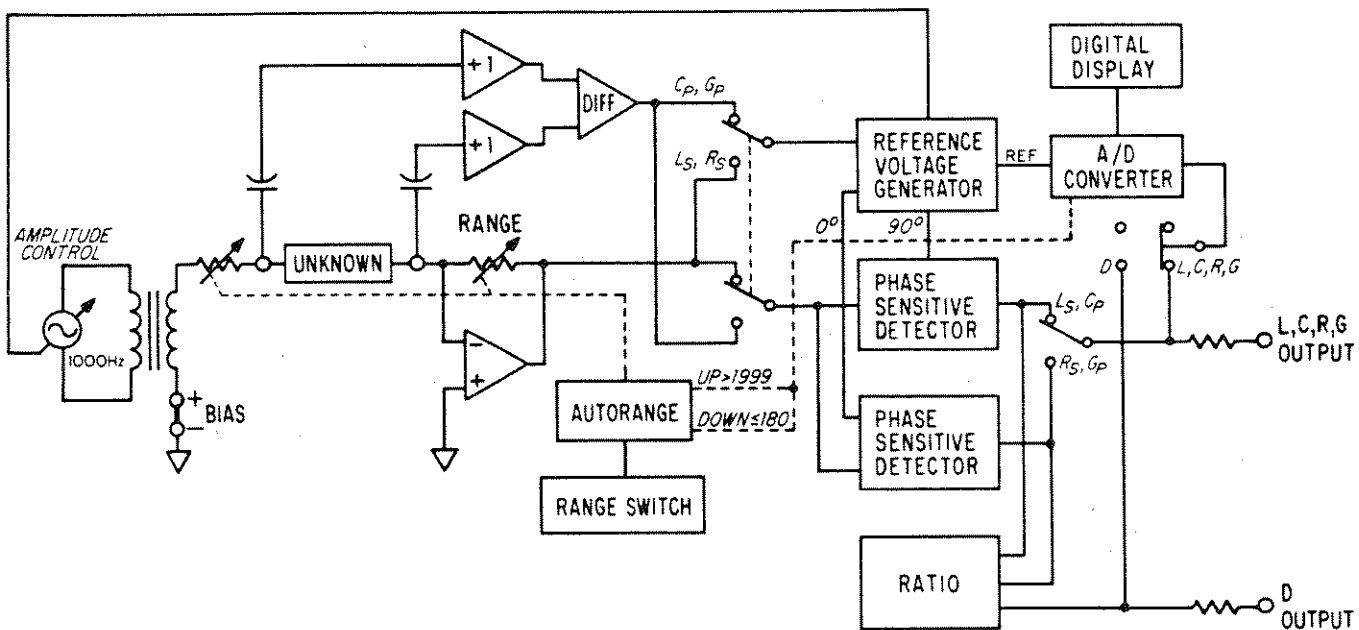

Figure 3-1. Model 253 Simplified Diagram

When measuring the dissipation factor (D) of inductors or capacitors, an analog ratio circuit is used. This circuit compares the loss component (Rs or Gp) to the reactive component (Ls or Cp) and presents a voltage proportional to D to the A/D Converter.

Analog output voltages are available at the rear of Model 253 for the selected function (L, C, R or G) and simultaneous D (for L or C unknowns).

### 3.2 DETAILED CIRCUIT DESCRIPTIONS

In the following descriptions several conventional resistor networks are involved. To identify which resistor elements are being discussed, the elements are identified by the lower terminal numbers and each is prefixed by a small letter "r". Example: U7 (r1 and r2).

### 3.2.1 1kHz Oscillator

The 1kHz signal applied to the unknown and range resistor is generated by a power op amp U2, used as a Wien bridge oscillator, with C20, C21 and U19 (r4 and r5) controlling the frequency. Amplitude control for the oscillator is provided by U27 working as a reference voltage null integrator and U35 as the feedback control element. Transformer T2 provides coupling to the unknown and range resistor with provision for inserting bias voltage at rear terminals.

### 3.2.2 Unknown Differential Amplifier

The voltage drop across the unknown is measured by differential amplifier U3-3. Amplifiers U1-3 and U1-4 act as high impedance AC-coupled buffers to prevent loading the unknown. Resistors U6 (r7 and r8) and U7 (r1 and r2) determine the gain ( $x1$ ) of U3-3. Trimmer R6 is an adjustment for common-mode voltage rejection. Amplifiers U3-2 and U3-3 are switch (U5) selectable gain stages that provide an overall gain of  $x1$ ,  $x10$  or  $x100$ . Trimmers R11 through R17, switched by U4, provide phase adjustments for each range.

### 3.2.3 Range Amplifier

The voltage drop across the range resistor (R22, R24 through R27), selected by U12, is measured by amplifier U1-2. Relay K1 switches R22 in series with the unknown for ranges  $20\Omega$  and  $2\Omega$  (or equivalent). For these ranges U36 is used as a gain amplifier of  $x1$  or  $x10$ . Other ranges use U36 as a guard amplifier to reduce the effect of shunt impedances on high value unknowns.

### 3.2.4 Reference Generator and Phase Sensitive Detector

#### Reference Generator

A DC voltage proportional to the voltage across the unknown or range resistor is generated by U13-2 and U13-3 used in an operational rectifier circuit. For reactive unknowns, amplifier U13-1 is used as the AC voltage reference input to the operational rectifier. Gating signals for the in-phase and quadrature phase sensitive detectors are produced by U15-3 and U15-4 used as zero crossing detectors. Trimmer R35 is used for adjustment of the  $90^\circ$  reference gate.

#### Phase Sensitive Detectors

Voltage across the unknown ( $R_s$  or  $L_s$ ) or across the range resistor ( $C_p$  or  $G_p$ ) is measured by two phase-sensitive detectors. The in-phase ( $0^\circ$ ) detector consists of amplifiers U17-1 and U30, together with resistor network U23 and switching gate U20. Ripple filtering is provided by R46, R47, C17, and C18. The quadrature ( $90^\circ$ ) detector consists of amplifiers U17-4 and U22, together with resistor network U21 and switching gate U20. Ripple filtering is provided by R41, R42, C13, C14, and C15. Trimmer R45 is used to adjust the full scale value of L or C.

### 3.2.5 Dissipation Factor Circuit

The dissipation factor (D) of inductors or capacitors is derived from the ratio of the loss component ( $0^\circ$  phase detector) and reactive component ( $90^\circ$  phase detector). This is done with a pulse-width modulator consisting of integrating amplifier U26 and resistor summing network using U28, R60 and R58. The ratio of R (or G) to L (or C) changes the pulse width ratio of the switching amplifier U27 (with switch U24) to produce a null at the integrator input. Comparator U15-2 acts as the switch driver and is frequency set by the test frequency of the instrument. Amplifiers U27-1 and U27-3 together with

switch U24 are the demodulator which produces an analog voltage proportional to the pulse width variation and scaled to equal the dissipation factor. Trimmer R52 adjusts full scale D value.

### 3.2.6 Overload Blanking Circuit

U15-1 is a comparator amplifier. It monitors the signal levels of the phase detector input and the level regulator amplifier U27-4. When either level exceeds its limit, comparator U15 goes low. This output is combined with a digital overrange signal at the input of a NAND gate of U29 to provide a display blanking output.

### 3.2.7 Analog to Digital Converter

The A/D converter resides in U31 (MC14433) which is a CMOS dual-slope integrating converter. This circuit provides a multiplexed output which is decoded and displayed by a plug-in circuit assembly (42916).

### 3.2.8 Function and Range Programming

A bipolar PROM (U33) stores the necessary range and function programming information for Model 253. The stored program has 32 addresses each with 8 bits of data. These addresses are reached by 2 function bits and 3 range bits which are set by the front panel switches.

### 3.2.9 Auto Range Circuit

The range programming PROM is interfaced to the range switch with a presettable counter U3 (Assy 43407). In the non-autorange positions the counter is in a preset mode and the PROM addressing follows the bit information of the switch. In the AUTO position, the counter takes information from the A/D converter. If the display exceeds 1999, the counter up-ranges and if the display is 180 or less, it down-ranges.

## SECTION 4

# MAINTENANCE

### WARNING

TO AVOID PERSONAL INJURY FROM ELECTRIC SHOCK DO NOT REMOVE INSTRUMENT COVERS OR PERFORM ANY MAINTENANCE OTHER THAN DESCRIBED IN THIS MANUAL. INSTALLATION AND MAINTENANCE PROCEDURES DESCRIBED IN THIS MANUAL ARE TO BE PERFORMED BY QUALIFIED SERVICE PERSONNEL ONLY.

#### 4.1 CALIBRATION PROCEDURE

Although Model 253 is inherently stable, good maintenance practices suggest it be calibrated every six months; more often if used in extreme environments or if inaccurate readings are suspected.

<u>Equipment Required</u>	<u>Minimum Specifications</u>
Frequency Counter	Measure 1000Hz with resolution of 1Hz
Digital Voltmeter	Resolution of 100 $\mu$ VDC
Resistance Standard	1000 $\Omega$ $\pm$ 0.05%, non-inductive such as ESI Model SR 1.
Capacitance Standard	100nF, $\pm$ 0.05%, silvered mica or polystyrene
Dissipation Factor Standards	1 $\mu$ F Decade Capacitor, 5 dial, polystyrene, $D < 0.0002$ ; 10 $\mu$ F polystyrene capacitor with D known to $\pm 0.001$ ; 100 $\mu$ F capacitor with D known to $\pm 0.001$
KELVIN KLIPS* Four-	ESI Part No. 43072
Terminal Clips	

Refer to Figure 4-1 for adjustment locations.

#### 4.1.1 Power Supply Check

Setup - Turn on instrument and allow ten minute warm-up period; then remove cover. Check - Power supply voltages at C44 and C45 should be + and -5V  $\pm 5\%$  (4.75V to 5.25V). Use rear panel COM terminal for voltmeter low input.

#### 4.1.2 Oscillator Adjust

Setup - Press R function button. Set RANGE switch to 2000 $\Omega$  and short unknown test leads together. Connect voltmeter high input to Test Socket (TS) pin (2) and frequency counter input to TS (1). Use rear panel COM terminal for circuit common. Adjustment - Set trimmer S for DVM reading of 0V ( $\pm 0.2$ V). Counter reading should be 1000Hz ( $\pm 10$ Hz).

#### 4.1.3 L, C, R, G Alignment

1. R, G PHASE DETECTOR ZERO TRIM. Setup - Press R function button and set RANGE switch to 2000 $\Omega$  and short unknown test leads together. Connect DVM input to TS (6). Adjustment - Set trimmer P for +0.3mV  $\pm 0.1$ mV on DVM.
2. UNKNOWN AMP COMMON MODE TRIM. Setup - Press R function button and set RANGE switch to 2 $\Omega$  and short unknown test leads together (keep movable jaws adjacent). Adjustment - Adjust trimmer J for DVM reading of 0V  $\pm 0.3$ mV at TS (6).
3. L, C PHASE DETECTOR ZERO TRIM. Setup - Press L function button and set RANGE switch to 200mH. Short unknown test leads together and connect DVM input to TS (5). Adjustment - Set trimmer M for +0.3mV  $\pm 0.1$ mV on DVM.



4. L, C, R, G OUTPUT AMP ZERO TRIM. Setup - Same as step 3 except connect DVM input to TS (4). Adjustment - Set trimmer V for  $0V \pm 0.3mV$  on DVM.
5. UNKNOWN AND RANGE AMP PHASE TRIM. Setup - Press C function button and set RANGE switch to  $200nF$ . Connect decade capacitor to unknown test leads and set at  $160nF (\pm 5\%)$ . Adjustment - Note voltage at TS (6) and then push L function button, again noting TS (6) voltage. The two should be equal ( $\pm 0.3mV$ ). If not, adjust trimmer X until they are. Next adjust trimmer D for  $0V \pm 0.3mV$  output at TS (6) for both L and C functions.
6. QUADRATURE GATE PHASE TRIM. Setup - Press R function button and set RANGE switch to  $2000\Omega$ . Connect  $1000\Omega (\pm 0.05\%)$  standard to unknown test leads. Adjustment - Set trimmer L for DVM reading of  $0V \pm 0.3mV$  at TS (5).
7. R, G FULL SCALE TRIM. Setup - Same as step 6. Adjustment - Set trimmer K for front panel digital reading of 1000. With DVM, read voltage at TS (4) and adjust trimmer R for  $+1.0V (\pm 0.5mV)$ .
8. L, C FULL SCALE TRIM. Setup - Press C function button and set RANGE switch to  $200nF$ . Connect  $100nF (\pm 0.05\%)$  standard to the unknown test leads. Adjustment - Set trimmer N for front panel reading of 1000.

#### 4.1.4 Dissipation Factor (D) Alignment

1. LOW LEVEL ZERO TRIM. Setup - Press C function button and set RANGE switch to  $200nF$ . Connect a low loss ( $D < 0.0002$ ) decade capacitor to unknown test leads. Adjustment - Set the decade capacitor to  $105nF$  and, with a DVM, note the voltage at TS (3) or D output terminal at the rear panel. Set the decade to  $5nF$  and

again note the voltage. If the two voltages are not equal ( $\pm 1\text{mV}$ ), adjust trimmer W until switching between  $105\text{nF}$  and  $5\text{nF}$  produces equal readings.

2. HIGH LEVEL ZERO TRIM. Setup - Same as step 1. Adjustment - Set decade capacitor to  $100\text{nF}$  and adjust trimmer U until voltage at TS (3) or D output is  $0\text{V} \pm 0.3\text{mV}$ .
3. D FULL SCALE TRIM. Setup - Same as step 1. Adjustment - Set the decade capacitor for a front panel C reading of  $159.2\text{nF}$ . Connect the  $1000\Omega$  standard resistor in parallel with the decade capacitor. Set trimmer T for a front panel D reading (push D button) of  $1.000$ .

**NOTE:** The following trim adjustments set  $D=0$  for all C ranges except  $200\text{nF}$ , which was adjusted in step 5 of Paragraph 4.1.3.

4.  $200\text{pF}$  RANGE D TRIM. Setup - Press C function button and set RANGE switch to  $200\text{pF}$ . Connect the low loss ( $D < 0.0002$ ) decade capacitor to unknown test leads. Adjustment - Set the decade to  $100\text{pF}$  ( $\pm 20\%$ ) and adjust trimmer H for  $0\text{V} \pm 0.3\text{mV}$  at TS (3), or D output.
5.  $2\text{nF}$  RANGE D TRIM. Setup - Same as step 4, except set RANGE switch to  $2\text{nF}$ . Adjustment - Set decade to  $1\text{nF}$  ( $\pm 20\%$ ) and adjust trimmer F for  $0\text{V} \pm 0.3\text{mV}$  at TS (3), or D output.
6.  $20\text{nF}$  RANGE D TRIM. Setup - Same as step 4, except set RANGE switch to  $20\text{nF}$ . Adjustment - Set decade to  $10\text{nF}$  ( $\pm 20\%$ ) and adjust trimmer E for  $0\text{V} \pm 0.3\text{mV}$  at TS (3), or D output.
7.  $2\mu\text{F}$  RANGE D TRIM. Setup - Same as step 4, except set RANGE switch to  $2\mu\text{F}$ . Adjustment - Set decade to  $1\mu\text{F}$  ( $\pm 20\%$ ) and adjust trimmer C for  $0\text{V} \pm 0.3\text{mV}$  at TS (3), or D output.

8. 20 $\mu$ F RANGE D TRIM. Setup - Set RANGE switch to 20 $\mu$ F and connect a 10 $\mu$ F ( $\pm 20\%$ ) capacitor (D known to  $\pm 0.001$ ) to unknown test leads. Adjustment - Adjust trimmer B for front panel D reading (push D button) equal to D value of the 10 $\mu$ F capacitor.
  
9. 200 $\mu$ F RANGE D TRIM. Setup - Set RANGE switch to 200 $\mu$ F and connect a 100 $\mu$ F ( $\pm 20\%$ ) capacitor (D known to  $\pm 0.001$ ) to unknown test leads. Adjustment - Adjust trimmer A for front panel D reading (push D button) equal to D value of the 100 $\mu$ F capacitor.

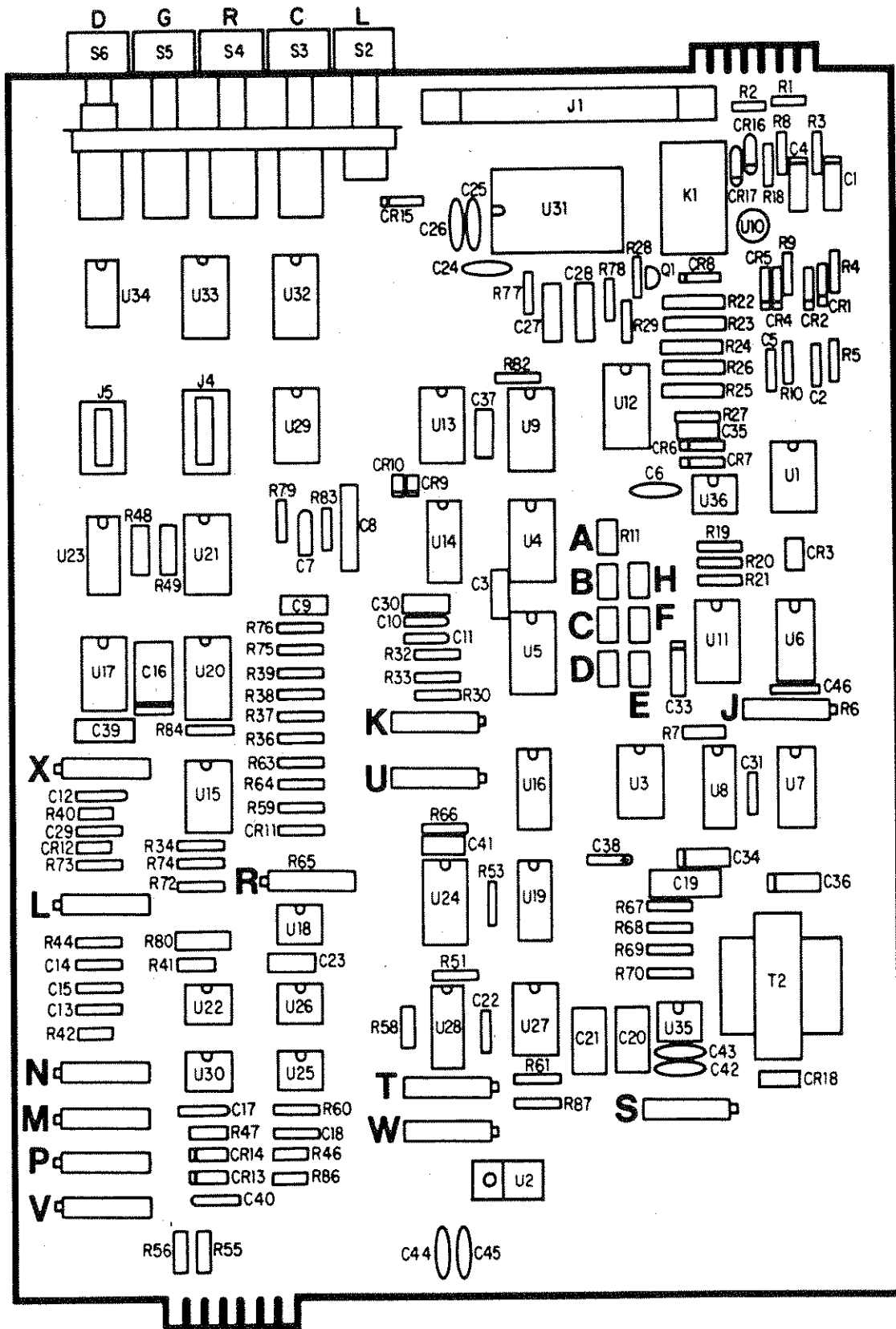

Figure 4-1.

## 4.2 MAINTENANCE

This section of the manual contains maintenance information for use in preventive maintenance, corrective maintenance, and troubleshooting of the Model 253.

### 4.2.1 Preventive Maintenance

**WARNING**

REMOVAL OF INSTRUMENT COVERS MAY CONSTITUTE AN ELECTRICAL HAZARD AND SHOULD BE ACCOMPLISHED BY QUALIFIED SERVICE PERSONNEL ONLY.

Preventive maintenance performed on a regular basis will improve the reliability of this instrument. It may include cleaning, visual inspection, or even monitoring the operating environment.

#### 4.2.1.1 Cleaning

**CAUTION**

AVOID THE USE OF CHEMICAL CLEANING AGENTS WHICH MIGHT DAMAGE THE PLASTICS USED IN THIS UNIT. DO NOT APPLY ANY SOLVENT CONTAINING KETONES, ESTERS OR HALOGENATED HYDROCARBONS. TO CLEAN, USE ONLY WATER SOLUBLE DETERGENTS, ETHYL, METHYL, OR ISOPROPYL ALCOHOL.

**Exterior.** Loose dust may be removed with a soft cloth or a dry brush. Water and mild detergent may be used; however, abrasive cleaners should not be used.

**Interior.** Use low-velocity compressed air to blow off the accumulated dust. Hardened dirt can be removed with a cotton-tipped swab, soft, dry cloth, or a cloth dampened with a mild detergent and water.

#### 4.2.1.2 Visual Inspection

This instrument should be inspected occasionally for such defects as broken connections, improperly seated semiconductors, damaged circuit boards, and heat-damaged parts.

The corrective procedure for most visible defects is obvious. If heat damaged components are found, particular care must be taken. Overheating usually indicates other trouble may be present in the instrument. It is important that the cause of overheating be corrected to prevent recurrence of the damage.

#### 4.2.2 Troubleshooting

The following troubleshooting information is provided to augment other sections of this manual. The Circuit Description and Part Lists and Schematic Diagrams sections should be used to full advantage. Section 3 in this manual gives circuit description information while, Section 5 contains the part lists and schematic diagrams.

##### 4.2.2.1 Troubleshooting Aids

**Schematic Diagrams.** Schematic diagrams are provided on foldout pages in Section 5. The electrical value and circuit numbers of each component are shown on the diagrams. Power supply voltages are also shown.

**Circuit-Board Illustrations.** Illustrations of circuit boards are shown along with the schematic diagrams. Each board-mounted electrical component is identified by its circuit number.

**Test Point Locations.** Test point locations have been indicated on both the schematic diagrams and the circuit-board illustrations.

**Component Color Code.** Colored stripes or dots on resistors and capacitors signify electrical values, tolerances, etc., according to the EIA standard color code. Components not color-coded usually have the value printed on the body.

**Multi-pin Connector Identification.** Multi-pin connectors are soldered to the circuit boards. They mate with ribbon type cable assemblies to carry signals between boards. Connector pin 1 is indexed with a number 1 etched on the circuit board. Each connector is identified by a P number and can be located by using the circuit board illustration in Section 5 of this manual. P numbers shown on the illustration correspond to the P numbers on the schematic diagrams.

#### 4.2.2.2 Troubleshooting Procedure

This troubleshooting procedure checks the simple trouble sources before proceeding with more extensive troubleshooting. The first few checks ensure proper connection and operation. If the trouble is not located by these checks, the remaining steps aid in locating the component. When the defective component is located, it should be replaced using the information given under Corrective Maintenance.

1. **Check Instrument Setup.** Make sure the instrument is properly plugged into a wall socket. Also, check the rear panel line voltage switch and the line fuse to see that they match the line voltage being used.
2. **Visual Check.** Visually check the portion of the instrument in which the trouble is suspected. Many problems can be located by visual indications such as unsoldered connections, broken wires, damaged circuit boards, damaged components, or components bent over and touching.
3. **Check Voltages.** A circuit stage may not be operating due to incorrect supply voltages. Typical supply voltages are given on

the diagrams; however, these are not absolute and may vary slightly between instruments.

4. **Trace the Signal.** The analog portion of the circuitry can be checked by tracing the signal with an oscilloscope. By noting where the signal disappears or distorts, the source of trouble can be located.
5. **Check Individual Components.** The following methods are provided for checking the individual components. Components which are soldered in place can sometimes be checked by disconnecting one end to isolate the measurement from the effects of surrounding circuitry.
  - a. **TRANSISTORS.** It is always best to check transistor operation under operating conditions. Transistors that are soldered to the circuit board should first be checked in-circuit using a dynamic transistor tester; then a replacement can be substituted to verify that the old transistor is bad. Socketed transistors can be checked by substituting a component known to be good; however, be sure that circuit conditions are not such that a replacement might also be damaged. If substitute transistors are not available, check the old transistor out-of-circuit using a dynamic tester. Be sure the power is off before attempting to remove or replace any transistor.
  - b. **INTEGRATED CIRCUITS.** Analog IC's such as comparators and operational amplifiers can usually be checked in-circuit with a voltmeter or test oscilloscope. An understanding of the device and circuit operation is essential for this type of troubleshooting. (For example, an op amp can be tested by measuring the input and output circuit voltages and comparing this ratio to the ratio of input and feedback resistors.)

Analog IC's that are socketed can also be checked out-of-circuit using a dynamic tester such as the ESI Model 1234.



Digital IC's are best checked in-circuit using a logic probe or voltmeter. Use care when checking voltages and waveforms around DIP (Dual-Inline-Package) IC's so that adjacent leads are not shorted together. A convenient means of connecting a test probe to 14 and 16 pin IC's is with an IC test clip. This device also doubles as an extraction tool.

- c. DIODES. A diode can be checked for an open or shorted condition by measuring the resistance between terminals with an ohmmeter set to the R X 1k scale. The diode resistance should be very high in one direction and very low when the meter leads are reversed.



DO NOT USE AN OHMMETER SCALE THAT HAS A HIGH INTERNAL CURRENT. HIGH CURRENTS MAY DAMAGE THE DIODES UNDER TEST.

- d. RESISTORS. Check resistors with an ohmmeter. Resistor tolerance is given in the Parts List. Resistors normally do not need to be replaced unless the measured value varies widely from the specified value.
- e. CAPACITORS. A leaky or shorted capacitor can be detected by checking resistance with an ohmmeter on the highest scale. Use an ohmmeter that will not exceed the voltage rating of the capacitor. (Be careful to observe correct polarity when checking electrolytic capacitors.) The resistance reading should be high after initial charge of the capacitor. An open capacitor can best be detected with a capacitance meter, or by checking whether the capacitance passes AC signals.

### 4.3 CORRECTIVE MAINTENANCE

Corrective maintenance consists of component replacement and instrument repair.

#### 4.3.1 Obtaining Replacement Parts

**Standard Parts.** All electrical and mechanical replacement parts for the Model 253 can be obtained from Electro Scientific Industries, Inc. However, many of the electronic components can be obtained locally in less time than is required to order them from ESI. Before purchasing or ordering replacement parts, check the parts list for value, tolerance, rating and description.

**NOTE:** When selecting replacement parts, it is important to remember that the physical size and shape of a component may affect the performance of the instrument. All replacement parts should be direct replacements unless it is known that a different component will not adversely affect instrument performance.

Order all special parts directly from Electro Scientific Industries.

### 4.3.2 Component Replacement

**WARNING**

DISCONNECT ALL POWER TO THE INSTRUMENT BEFORE REPLACING COMPONENTS. FAILURE TO DO SO MAY RESULT IN ELECTRICAL SHOCK.

**Semiconductor Replacement.** Replacement semiconductors should be of the original type or a direct replacement. If the replacement semiconductor is not of the original type, check the manufacturer's basing diagram for proper lead identification.

**Free Standing Components.** When replacing any components that are free-standing (not directly mounted to circuit boards), be sure to place the new components in the same physical location and position as the old components. If this is not done, there may be a possibility of components touching and causing a short circuit.

#### 4.4 REPACKAGING FOR SHIPMENT

If the Model 253 is to be shipped back to ESI for service or repair, attach a tag showing: owner (with address) and the name of an individual at your firm that can be contacted, complete instrument serial number and a description of the service required.

Save and re-use the package in which your instrument was shipped. If the original packaging is unfit for use or not available, repackage the instrument as follows:

1. Obtain a carton of corrugated cardboard having inside dimensions of not less than six inches more than the instrument dimensions; this will allow for cushioning.
2. Surround the unit with polyethylene sheeting to protect the finish of the instrument.
3. Cushion the instrument on all sides by tightly packing dunnage of urethane foam between the carton and the instrument allowing three inches on all sides.
4. Seal the carton with shipping tape or an industrial stapler.

## SECTION 5

### PARTS LISTS AND DIAGRAMS

#### 5.1 MAINFRAME PARTS (30253)

<u>DESCRIPTION</u>	<u>ESI PART NO.</u>	<u>SEE FIGURE NO.</u>
Assembly, Back Panel (includes Circuit Assembly, Power Supply)	43157 (42903)	5-5 (5-6)
Assembly, Cable, Auto Range Control	43766	
Assembly, Cable, KELVIN KLIPS®	43072	
Assembly, Range Switch	43721	
P1 Header, 16 Pin, DIP	20799	
S1 Switch, Range	43654	
Circuit Assembly, Auto Range	43407	5-4
Circuit Assembly, Display	43668	5-3
Circuit Assembly, Motherboard	43064	5-1, 5-2
Cover, Chassis	42988	
Display Window, Acrylic	43116	
Foot, Rubber	08739	
Frame, Front Panel	43068	
Front Panel Overlay	43431	
Handle, Kit	43088	
Instruction Manual	43761	
Knob, Range Switch	22593	
Pushrod, Power Switch	43143	

#### Options:

Front Panel Dust Cover	43374
Sorting Fixture	Model 2001
Sorting Fixture Cable Assembly (4BNC)	43586

## 5.2 MOTHERBOARD CIRCUIT ASSEMBLY (Part No. 43064)

<u>CIRCUIT NO.</u>	<u>DESCRIPTION</u>	<u>ESI PART NO.</u>	
C1, C4	Capacitor, 0.047 $\mu$ F, 200V, Mylar	12239	
C2, C5, C13	Capacitor, 1 $\mu$ F, 35V, Tant	06472	C17,
C18, C22, C29			
C3, C37, C39	Capacitor, 1000pF, 500V, Poly	07094	
C6	Capacitor, 3.3pF, 1kV, Disc	01925	
C7, C12	Capacitor, 6.8 $\mu$ F, 35V, Tant	25339	
C8	Capacitor, 2000pF, 500V Mica	02158	
C9, C19, C23, C28	Capacitor, 0.1 $\mu$ F, 200V, Mylar	12121	C27,
C10, C11, C14, C15, C31, C38, C40	Capacitor, 2.2 $\mu$ F, 20V, Tant	13283	
C16	Capacitor, 0.33 $\mu$ F, 200V, Mylar	12446	
C20, C21	Capacitor, 0.0159 $\mu$ F, 1%, 100V	18845	
C24-C26, C42-C45	Capacitor, 0.05 $\mu$ F, 50V, Disc	12116	
C30	Capacitor, 390pF, 600V, Poly	29299	
C33	Capacitor, 0.01 $\mu$ F, 100V, Mylar	12260	
C34	Capacitor, 0.0033 $\mu$ F, 100V, Mylar	20879	
C35	Capacitor, 91pF, 2%, 600V Silver Mica	43738	
C36	Capacitor, 0.0022 $\mu$ F, 100V, Mylar	12399	
C41	Capacitor, 220pF, 600V, Poly	29297	
C46	Capacitor, 560pF, 600V, Poly	25922	
CR1, CR2, CR4, CR5 CR9-CR12, CR15	Diode, 1N914	12356	
CR3	Diode Bridge, Mini DIP	26339	
CR6-CR8	Diode, 1N4005	01779	
CR13, CR14	Diode, 1N4732, Zener	12449	
CR16, CR17	Diode, 1N4738, Zener, 8.2V	12160	
CR18	Transorb, 10V	42632	
J1	Connector, 24 pin, PC	43081	
K1	Relay, 12V, 4PDT, PC MT	43083	
Q1	Transistor, 2N3702	12041	
R1-R3, R8, R29, R32, R41, R46, R56, R87	Resistor, 1k $\Omega$ , 10%, 1/4W	13920	
R4, R5, R9, R10 R18, R68, R70	Resistor, 100k $\Omega$ , 10%, 1/4W	13945	
R6	Resistor, Trimmer, 200 $\Omega$ , 15 Turn	12083	
R7	Resistor, 30.1k $\Omega$ , 1%, 1/8W	43082	
R11-R17	Resistor, Trimmer, 100k $\Omega$ , 1 Turn	43092	
R19	Resistor, 18k $\Omega$ , 10%, 1/4W	13936	
R20, R28	Resistor, 2.2k $\Omega$ , 10%, 1/4W	13924	
R21	Resistor, 220 $\Omega$ , 10%, 1/4W	13911	
R22	Resistor, 1.001 $\Omega$ , ESI, QB, 4T	43302	
R23, R25	Resistor, 1k $\Omega$ , ESI, QB	24940	
R24	Resistor, 100 $\Omega$ , 0.02%, ESI, QB	24939	
R26	Resistor, 10k $\Omega$ , ESI, QB	24941	
R27	Resistor, 100k $\Omega$ , 0.1%, MF	43300	
R30	Resistor, 1.8k $\Omega$ , 10%, 1/4W	13923	

<u>CIRCUIT NO.</u>	<u>DESCRIPTION</u>	<u>ESI PART NO.</u>
R31, R35, R65	Resistor, Potentiometer, 1k $\Omega$ , 15 Turn	18469
R33	Resistor, 33 $\Omega$ , 10%, 1/4W	43301
R34	Resistor, 3.32k $\Omega$ , 1%, 1/8W	21771
R36-R40, R79	Resistor, 10k $\Omega$ , 10%, 1/4W	13933
R42, R47	Resistor, 68 $\Omega$ , 10%, 1/4W	13902
R43, R45, R50, R85	Resistor, Potentiometer, 10k $\Omega$ , 15 Turn	20145
R44	Resistor, 11k $\Omega$ , 1%, 1/4W	13359
R48, R49	Resistor, 90.9k $\Omega$ , 1%, 1/4W	24557
R51, R58	Resistor, 100k $\Omega$ , 1%, 1/4W	21750
R52	Resistor, Potentiometer, 2k $\Omega$ , 15 Turn	12084
R53	Resistor, 2.2M $\Omega$ , 10%, 1/4W	13962
R54, R62	Resistor, Potentiometer, 100k $\Omega$ , 15 Turn	21455
R55, R86	Resistor, 470 $\Omega$ , 10%, 1/4W	13915
R57	Resistor, Potentiometer, 20k $\Omega$ , 15 Turn	21199
R59, R75, R76	Resistor, 22k $\Omega$ , 10%, 1/4W	13937
R60, R84	Resistor, 4.99k $\Omega$ , 1%, 1/4W	21737
R61, R77	Resistor, 470k $\Omega$ , 10%, 1/4W	13955
R63, R64	Resistor, 4.7k $\Omega$ , 10%, 1/4W	13927
R66, R80	Resistor, 2k $\Omega$ , 1%, 1/4W	21733
R67	Resistor, 82k $\Omega$ , 10%, 1/4W	24812
R69	Resistor, 100 $\Omega$ , 10%, 1/4W	13907
R71	Resistor, Potentiometer, 500 $\Omega$ , 15 Turn	12093
R72	Resistor, 20k $\Omega$ , 1%, 1/4W	21743
R73	Resistor, 31.6k $\Omega$ , 1%, 1/4W	21745
R74	Resistor, 63.4k $\Omega$ , 1%, 1/4W	21718
R78	Resistor, 316k $\Omega$ , 1%, 1/4W	21755
R82	Resistor, 10k $\Omega$ , 1%, 1/8W, MF	21740
R83	Resistor, 402k $\Omega$ , 1%, 1/8W, MF	21756
S2-S6	Switch, 5 Station, Pushbutton	42882
T2	Transformer, Coupling	42964
U1, U3, U13, U17	IC, 3403	40840
U2	IC, 759	43098
U4	IC, 4051	40841
U5, U9, U20, U24	IC, 4053	20744
U6, U8	Resistor Network, 1k $\Omega$ , 0.5%, 8 Resistors	43117
U7, U14, U16, U19, U21, U23, U28	Resistor Network, 10k $\Omega$ , 0.5%, 8 Resistors	43077
U10	LED Isolator, CLM 6000	25940
U11, U12	IC, 4052	20743
U15	IC, 339	40849
U18	IC, Precision 2.5V REF, 1403	43099
U22, U30	IC, 741	20668
U25, U36	IC, 356H	41473
U26	IC, 741K	21625
U27	IC, TL074	43299
U29	IC, 4012	43086
U31	IC, 14433	43067

<u>CIRCUIT NO.</u>	<u>DESCRIPTION</u>	<u>ESI PART NO.</u>
U32	IC, 4049	41305
U33	IC, 6331N	43104
U34	Resistor Network, 22k $\Omega$ , 13 Res	20712
U35	IC, 3080	20723
	PC Board, Motherboard	43063
	Socket, 8 Pin, DIP for U18, U22, U25, U26, U30, U35 and U36	22410
	Socket, 14 Pin, DIP for J5, U1, U3, U13, U15, U17, U27 and U29	19189
	Socket, 16 Pin, DIP for J4, U4, U5, U9, U11, U12, U20, U24, U32 and U33	20860
	Socket, 24 Pin, DIP for U31	41492



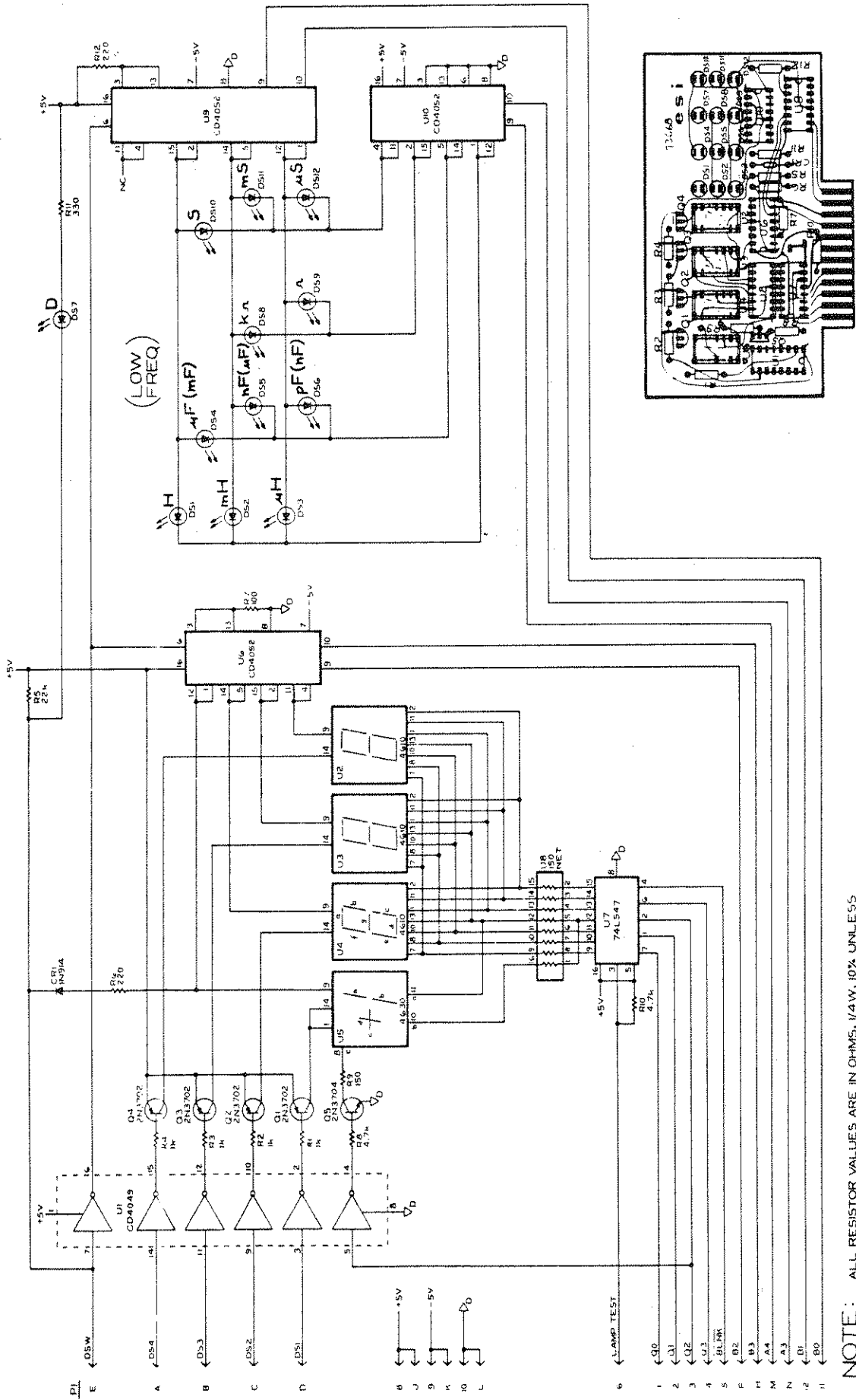
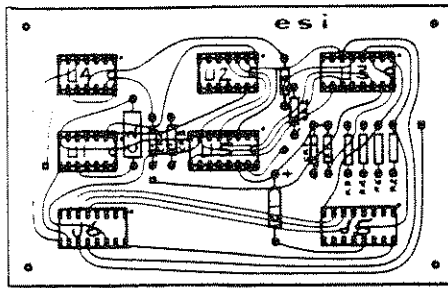

Figure 5-3. Display Circuit Assembly

## 5.4 AUTORANGE CIRCUIT ASSEMBLY (Part No. 43407)

<u>CIRCUIT NO.</u>	<u>DESCRIPTION</u>	<u>ESI PART NO.</u>
CR1-CR4	Diode, IN914A	12356
C1	Capacitor, 2.2 $\mu$ F, 20V, Tantalum	13283
C2	Capacitor, 100pF, 500V, Poly	07094
R1	Resistor, 470k $\Omega$ , $\pm$ 10%, 1/4W	13955
R2-R4,R6	Resistor, 22k $\Omega$ , $\pm$ 10%, 1/4W	13937
R5	Resistor, 15k $\Omega$ , $\pm$ 10%, 1/4W	13935
U1	IC, 4011	20725
U2	IC, 4012	43086
U3	IC, 4029	40843
U4	IC, 4030	40844
U5	IC, 4049	41305
	PC Board, Autorange	43406
	Socket, 14 Pin, DIP for U1, U2 and U4	19189
	Socket, 16 Pin, DIP for U3, U5, J5 and U6	20860



IC POWER			
CKT REF	5V	0V	NC
U5	1	8	13,16
U3	16	8	
U2	14	7	6,8
U1, U4	14	7	

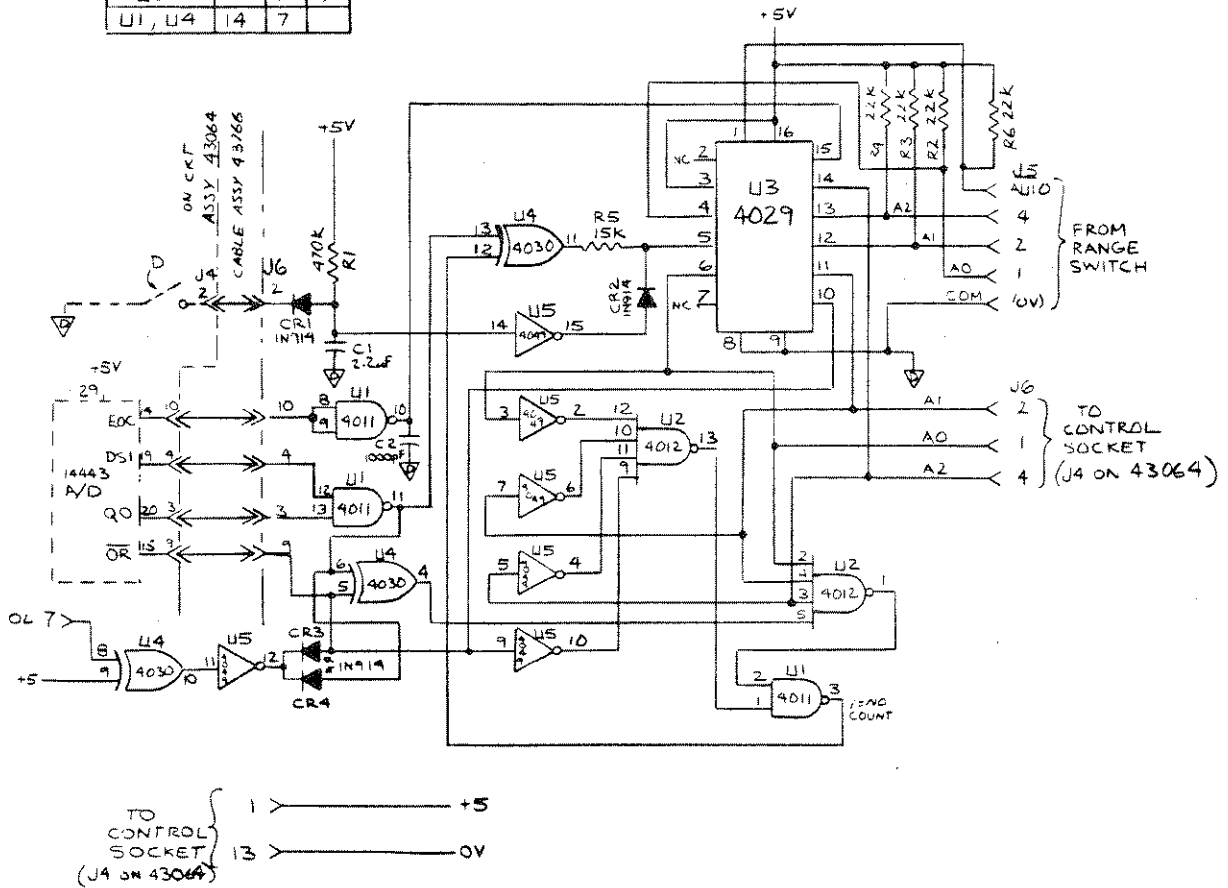
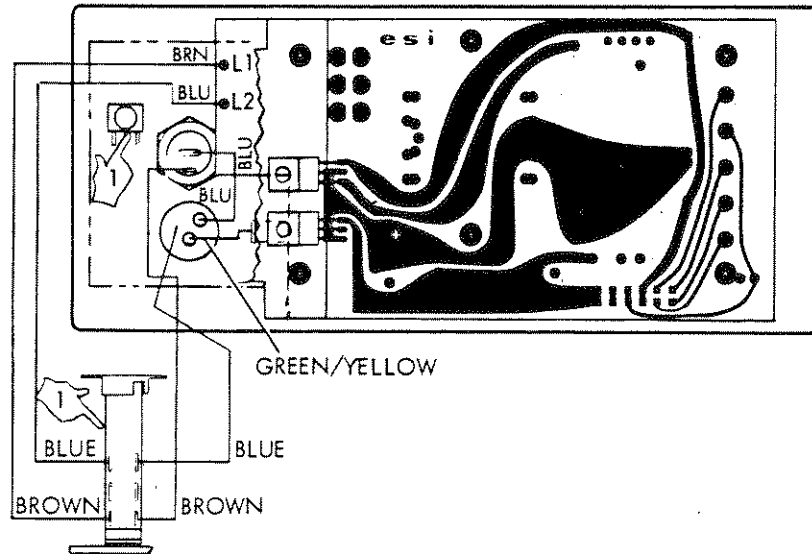

Figure 5-4. Autorange Circuit Assembly

5.5 BACK PANEL ASSEMBLY (Part No. 43157)

<u>CIRCUIT NO.</u>	<u>DESCRIPTION</u>	<u>ESI PART NO.</u>
F1	Fuse, 115V line voltage, 1/16A 250VAC Slow Blow	08952
F1	Fuse, 230V line voltage, 1/20A 250VAC Slow Blow	53327
S1	Power Switch	23164
U1	Voltage Regulator, 7805	20699
U2	Voltage Regulator, LM320T-5	41876
	Back Panel	42986
	Ckt Assy, Power Supply	42903
	Bracket, Instrument Cord Wrap	43768
	Bracket, Switch Support	43052
	Wrap, Switch Support	43138
	Fuse Holder Body, Low Profile	45967
	Fuse Carrier, 3AG, Gray	45966
	Fuse Carrier, 5x20mm, Black	45965
	Power Cord	24077



1 WIRING DETAIL OF SWITCH

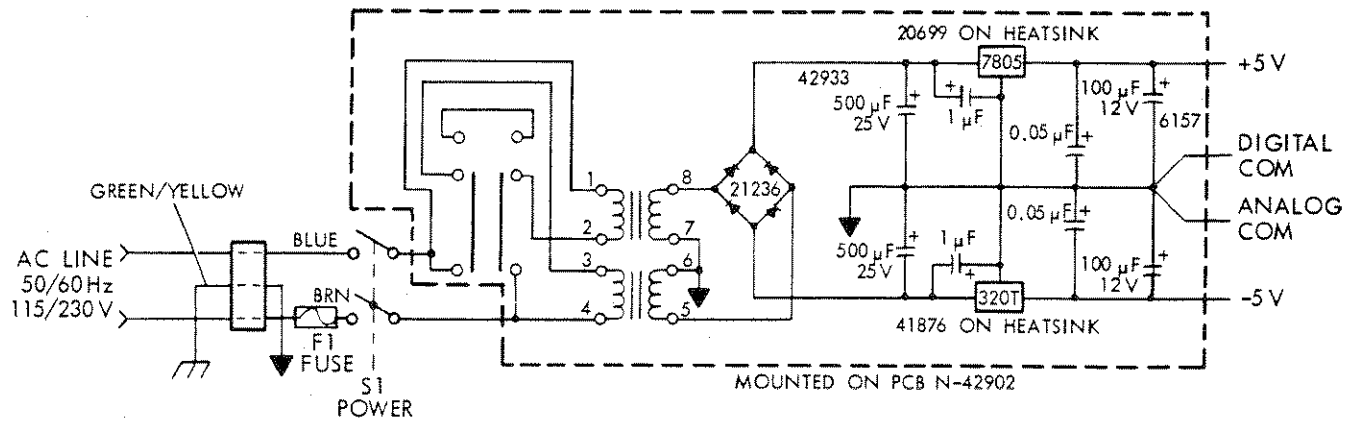
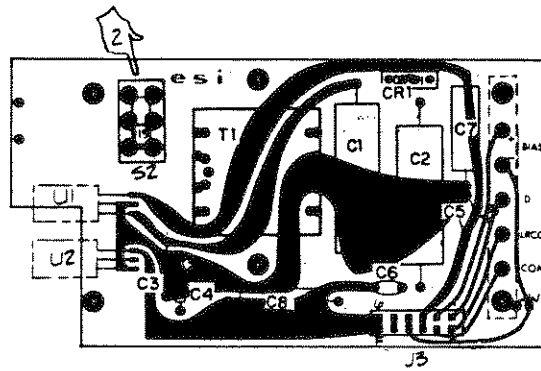

Figure 5-5. Rear Panel Assembly

5.6 POWER SUPPLY CIRCUIT ASSEMBLY (Part No. 42903)

<u>CIRCUIT NO.</u>	<u>DESCRIPTION</u>	<u>ESI PART NO.</u>
C1, C2	Capacitor, 500 $\mu$ F, 25V	42938
C3, C4	Capacitor, 1 $\mu$ F, Tantalum	06472
C5, C6	Capacitor, 0.05 $\mu$ F, Disc	12116
C7, C8	Capacitor, 100 $\mu$ F, 12V	06157
CR1	Bridge, Full Wave	21236
J3	Connector, 6 Position	43101
S2	Switch, Slide (230/115V)	29233
T1	Transformer	43303
TB1	Barrier Strip, 5 Position	43079
W1	Wire, No. 20 Copper	
	PC Board, Power Supply	42902
	Shorting Strap	43308



**NOTE:**

1. ALL CAPACITOR VALUES ARE IN  $\mu$ F UNLESS OTHERWISE SPECIFIED.

2 SWITCH IS SHOWN IN 115 V POSITION.

3 U1, U2 MOUNTED TO SWITCH SUPPORT BRACKET N° 43052 AT THE ASSY., BACK PANEL N° 43157.

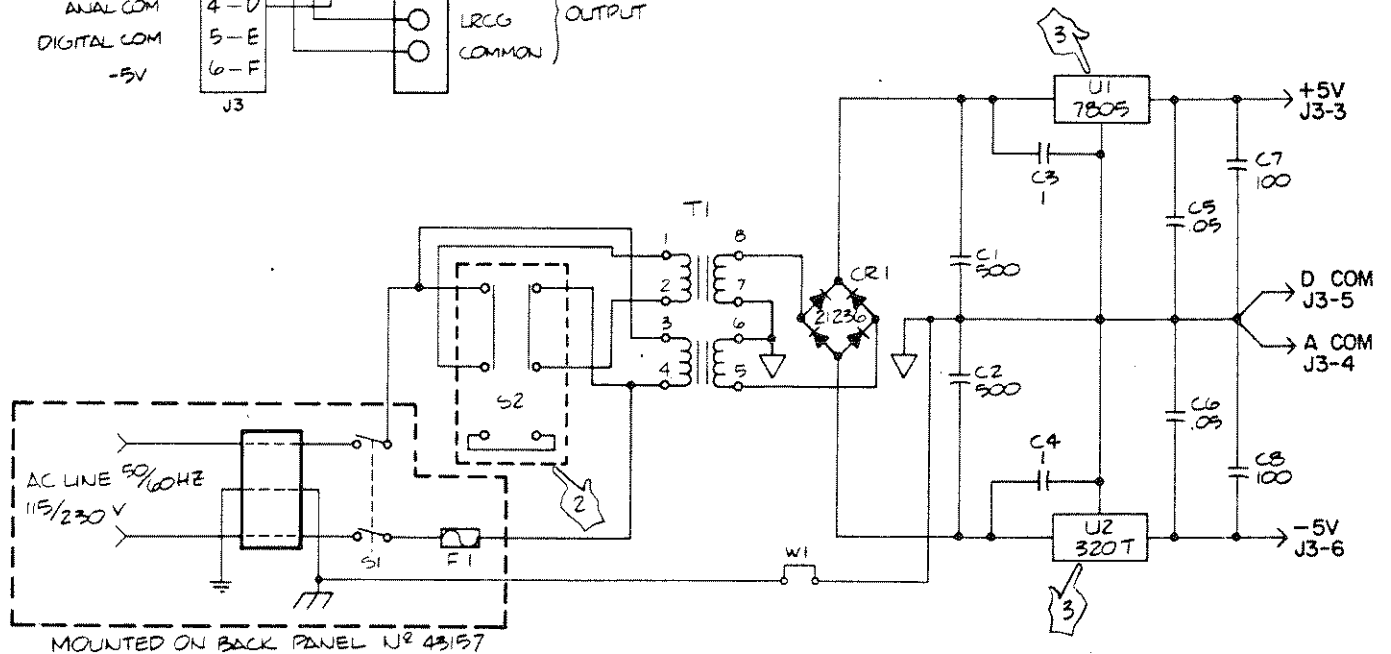
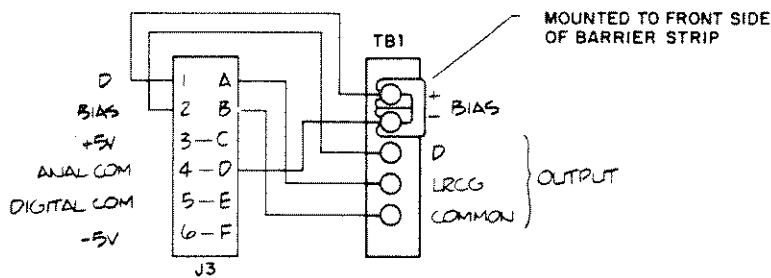
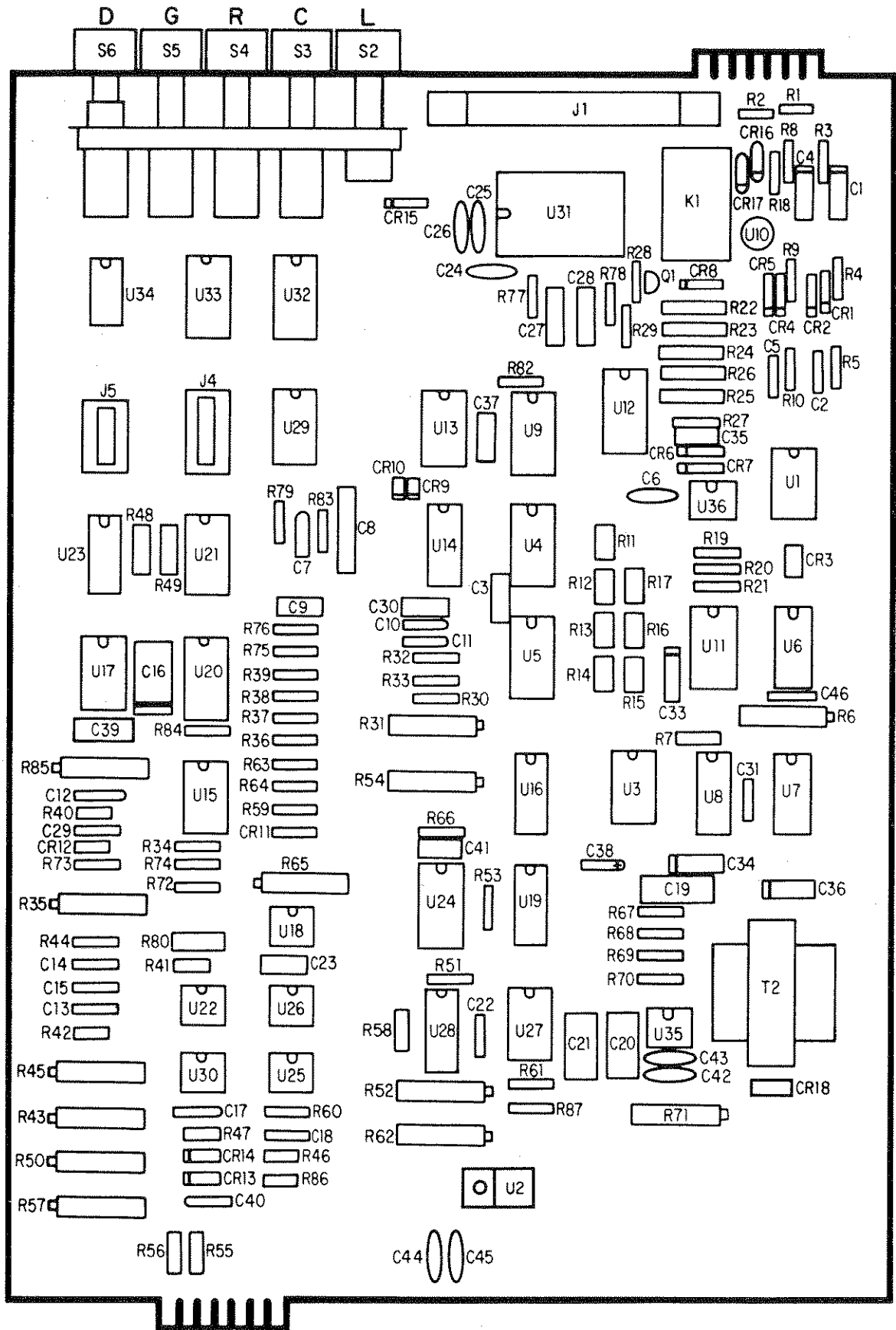
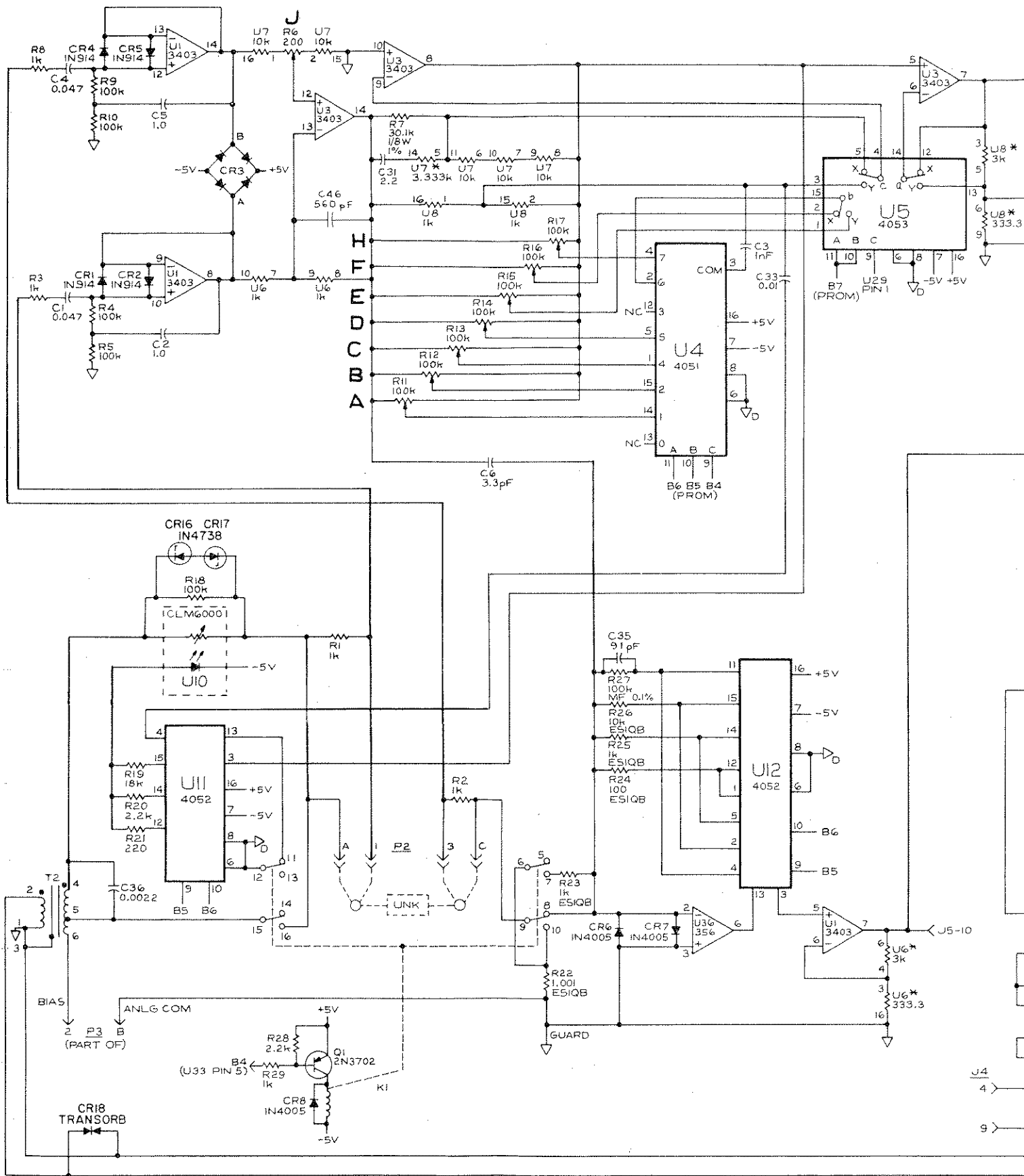

Figure 5-6. Power Supply









**NOTE:**

1. ALL RESISTOR VALUES ARE IN OHMS, 1/4 W, 10% UNLESS OTHERWISE STATED.
2. ALL CAPACITORS ARE IN  $\mu$ F UNLESS OTHERWISE STATED.
3. LARGE BOLD ALPHABET LETTERS DESIGNATED ON PC BOARD FOR TRIMPOT REFERENCE.
4. ASTERISK (\*) DENOTES EQUIVALENT RESISTANCE VALUES FROM SERIES OR PARALLEL COMBINATIONS WITHIN THE RESISTANCE NETWORK PACKAGES.

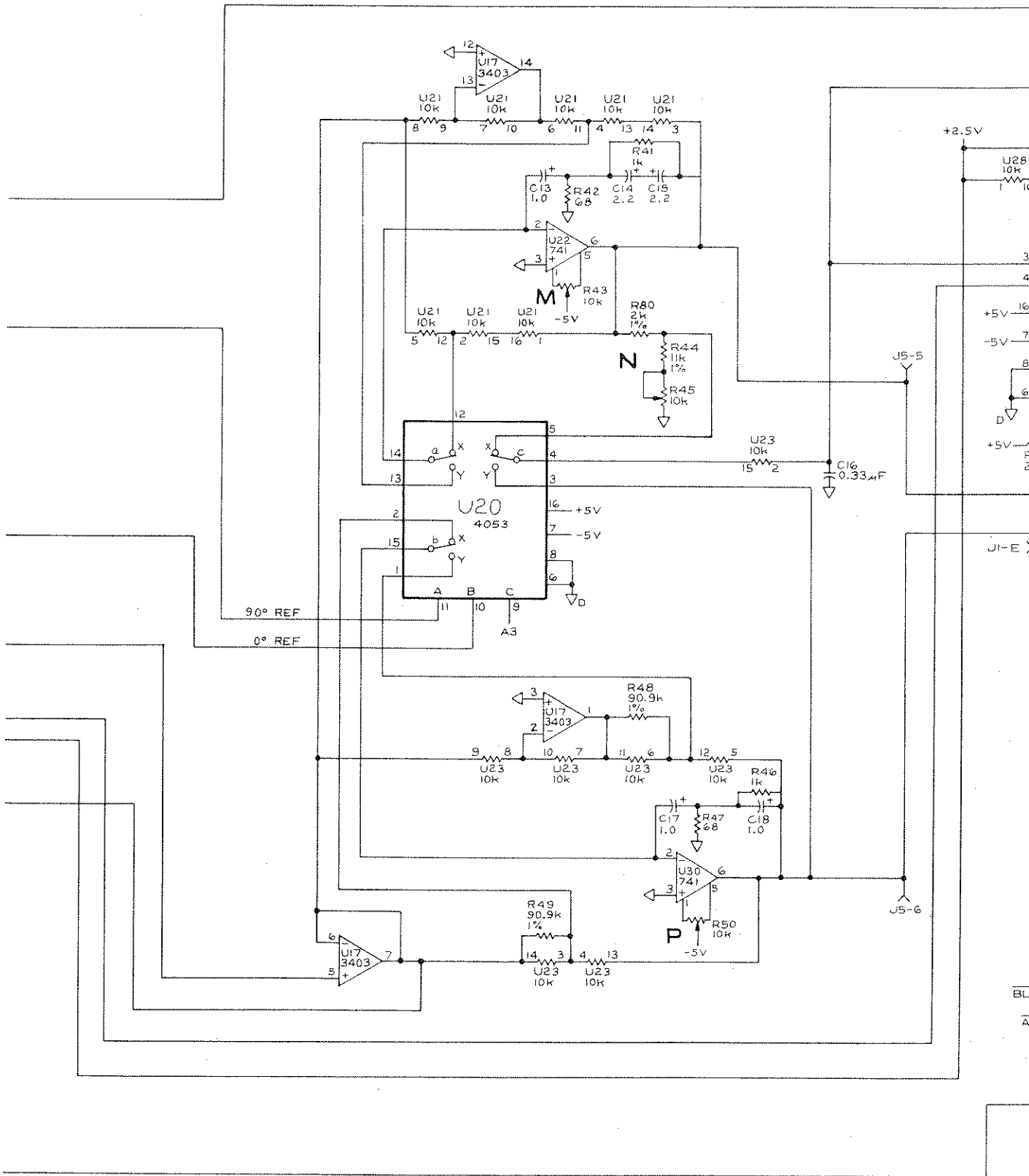

NOTE:

5 S2 WHEN ENGAGED, RELEASES C, R, OR G FUNCTIONS (S3, S4 & S5).

ANAL



## Warranty of Quality

Electro Scientific Industries, Inc. warrants its products to be free from defects in material and workmanship. Rigorous quality control permits the following standard new equipment warranties:

1. Two years for components and instruments utilizing passive circuitry.
2. One year on components and instruments utilizing active circuitry. One year on test fixtures.

During the in-warranty periods, we will service or, at our option, replace, at the factory, any device that fails in normal use to meet its published specifications. Batteries, tubes and relays that have given normal service are excepted.

## Warranty of Traceability

The reference standards of measurement of Electro Scientific Industries, Inc., are compared with the U.S. National Standards through frequent tests by the U.S. National Institute of Standards and Technology. The ESI working standards and testing apparatus used are calibrated against the reference standards in a rigorously maintained program of measurement control.

The manufacture and final calibration of all ESI instruments are controlled by use of the ESI reference and working standards and testing apparatus in accordance with established procedures and documented results. (Reference MIL-STD-45662A)

## Disclaimer of Implied Warranties

The foregoing warranties of ESI are in lieu of all other warranties, express or implied. ESI specifically disclaims any implied warranties of merchantability or fitness for a particular purpose. In no event will ESI be liable for special or consequential damages. Purchaser's sole and exclusive remedy in the event any item fails to comply with the foregoing express warranties of ESI shall be to return the item to ESI, shipping charges prepaid, and at the option of ESI obtain a replacement item or a refund of the purchase price.

Where ESI product will interconnect with components not supplied by ESI, ESI does not warrant the ESI product against failures caused by mismatch of the non-ESI component to the ESI product nor will ESI be liable for damages to the non-ESI component resulting from mismatch.



13900 N.W. Science Park Drive Portland, Oregon 97229 Telephone 503/641-4141, Telex 4742064

P/N 67215B 1/90

