

For the benefit and convenience of its customers, Fluke Corporation (Fluke) has reproduced this copy of a manual which is no longer in production. This manual has not been edited or updated since the revision date shown on the *lower left hand corner of the first page*. Fluke will not be liable for any claims, losses or damages of any kind incurred by any user arising from use of this manual.

# FLUKE

## 77/75/73/70/23/21

# Series II Multimeter

Service Manual

PN 896204

July 1991 Rev. 1, 9/92

©1992 John Fluke Mfg., Inc. All rights reserved. Litho in U.S.A.

**FLUKE®**

## OPERATOR SAFETY INFORMATION

This meter has been designed and tested according to IEC Publication 348. Follow all safety and operating instructions to ensure that the meter is used safely and is kept in good operating condition.

- Never use the meter if the meter or test leads look damaged.
- Always turn off power to the circuit before cutting, unsoldering, or breaking the circuit. Small amounts of current can be dangerous.
- Never measure resistance in a circuit when power is applied to the circuit.
- Never touch the probes to a voltage source when the test leads are plugged into the 10A or 300 mA input jack.
- To avoid damage or injury, never use the meter on unprotected circuits that exceed 4800 volt-amps.
- Never apply more than 1000V dc or 750V ac rms (sine) between any input jack and earth ground.
- Always be careful when working with voltages above 60V dc or 30V ac rms. Such voltages pose a shock hazard.
- Always keep your fingers behind the finger guards on the probe when making measurements.
- Always use a high voltage probe to measure voltage if the peak voltage might exceed 1000V.

### SYMBOLS MARKED ON EQUIPMENT



DANGER - High voltage.



Attention - refer to the manual. This symbol indicates that information about usage of a feature is contained in the manual.



Fuse information.

### USE THE PROPER FUSE

To avoid fire hazard, use only a fuse identical in type, voltage rating, and current rating as specified on the case bottom fuse rating label.

### DO NOT OPERATE DISASSEMBLED METER

Always operate the meter with case top and bottom properly assembled.

Access procedures and the warnings for such procedures are contained in this Service Manual. Service procedures are for qualified service personnel only.

### DO NOT ATTEMPT TO OPERATE IF PROTECTION MAY BE IMPAIRED

If the meter appears damaged or operates abnormally, protection may be impaired. Do not attempt to operate it. When in doubt, have the meter serviced.

# Table of Contents

SECTION	TITLE	PAGE
<b>1</b>	<b>Introduction and Specifications .....</b>	<b>1-1</b>
1-1.	INTRODUCTION .....	1-3
1-2.	ORGANIZATION OF THE SERVICE MANUAL .....	1-3
1-3.	CONVENTIONS .....	1-4
1-4.	SPECIFICATIONS .....	1-4
<b>2</b>	<b>Theory of Operation .....</b>	<b>2-1</b>
2-1.	INTRODUCTION .....	2-3
2-2.	FUNCTIONAL BLOCK DESCRIPTION .....	2-3
2-3.	DETAILED DESCRIPTION .....	2-3
2-4.	Voltage Signal Conditioning .....	2-3
2-5.	Current Conditioning .....	2-4
2-6.	Ohms .....	2-4
2-7.	Additional Circuitry .....	2-4
2-8.	AC CONVERTER .....	2-4
2-9.	ACTIVE FILTER .....	2-4
2-10.	ROTARY SWITCH .....	2-5
2-11.	A/D CONVERSION .....	2-5
<b>3</b>	<b>Maintenance .....</b>	<b>3-1</b>
3-1.	INTRODUCTION .....	3-3
3-2.	PCA ACCESS AND GENERAL MAINTENANCE .....	3-3
3-3.	DISPLAY ACCESS .....	3-4
3-4.	CLEANING .....	3-4
3-5.	PERFORMANCE TESTS .....	3-6
3-6.	Initial Procedure .....	3-6
3-7.	Display Test .....	3-6
3-8.	DC Voltage Test .....	3-6
3-9.	AC Voltage Test .....	3-7
3-10.	Resistance Test .....	3-8
3-11.	Diode Test .....	3-8
3-12.	DC mA Test (75/21 & 77/23 Only) .....	3-9
3-13.	DC Amps Test (73, 75/21, and 77/23 Only) .....	3-9
3-14.	CALIBRATION .....	3-9
3-15.	TROUBLESHOOTING .....	3-9
3-16.	Supplemental Troubleshooting Procedures .....	3-11

## Table of Contents

---

SECTION	TITLE	PAGE
3-17.	CHECKING THE CRYSTAL OSCILLATOR.....	3-11
3-18.	CHECKING THE REFERENCE VOLTAGE .....	3-11
3-19.	CHECKING DISPLAY DRIVE VOLTAGE .....	3-11
3-20.	CHECKING BEEPER DRIVE SIGNAL .....	3-11
3-21.	TRACING THE VDC SIGNAL PATH.....	3-11
<b>4</b>	<b>List of Replaceable Parts .....</b>	<b>4-1</b>
4-1.	INTRODUCTION .....	4-3
4-2.	HOW TO OBTAIN PARTS .....	4-3
4-3.	TECHNICAL SERVICE CENTERS.....	4-3
<b>5</b>	<b>Schematic Diagrams .....</b>	<b>5-1</b>

# List of Tables

TABLE	TITLE	PAGE
1-1.	Specifications .....	1-5
2-1.	S1 Function Codes .....	2-6
3-1.	Recommended Test Equipment .....	3-4
3-2.	DC Voltage Test .....	3-7
3-3.	AC Voltage Test .....	3-7
3-4.	Resistance Test .....	3-8
3-5.	DC mA Test .....	3-9
3-6.	DC Amps Test .....	3-9
5-1.	Abbreviations .....	5-2

# List of Illustrations

FIGURE	TITLE	PAGE
2-1.	Overview .....	2-3
2-2.	Ohms Function .....	2-5
2-3.	AC and A/D Converter .....	2-7
3-1.	Assembly Details .....	3-5
3-2.	Display .....	3-6
3-3.	Troubleshooting Tree .....	3-10
5-1.	A1 Main PCA .....	5-3
5-2.	Signal Flow Diagram .....	5-5

# Section 1 Introduction and Specifications

## CONTENTS

	PAGE
1-1. INTRODUCTION.....	1-3
1-2. ORGANIZATION OF THE SERVICE MANUAL.....	1-3
1-3. CONVENTIONS.....	1-4
1-4. SPECIFICATIONS.....	1-4

**INTRODUCTION****1-1.**

This manual presents service information for the Fluke 70, 73, 75, 77, 21, and 23 Series II Multimeters. The manual includes a theory of operation, general maintenance procedures, performance tests, calibration procedures, troubleshooting information, a list of replaceable parts, and schematic diagrams.

A meter under warranty will be promptly repaired or replaced (at Fluke's option) and returned at no charge. See the registration card for warranty terms. If the warranty has lapsed, the meter will be repaired and returned for a fixed fee. Contact the nearest Service Center for information and prices. A list of U.S. and International Service Centers is included at the end of Section 4 of this manual.

**ORGANIZATION OF THE SERVICE MANUAL****1-2.**

The following descriptions briefly describe each section in the manual.

**SECTION 1. INTRODUCTION AND SPECIFICATIONS**

This section describes use of the Service Manual and application of special terminology (conventions) to describe the meter's circuitry. A complete set of specifications appears at the end of this section.

**SECTION 2. THEORY OF OPERATION**

This section first categorizes instrument circuitry into functional blocks, with a description of each block's role in overall operation. A detailed circuit description is then given for each block. These descriptions explore operation to the component level and fully support troubleshooting and repair procedures defined in Section 3.

**SECTION 3. MAINTENANCE**

Provides complete maintenance information, from general maintenance and cleaning instructions to detailed troubleshooting and repair procedures to the component level. Troubleshooting and repair procedures rely heavily on both the Theory of Operation presented in Section 2 and the Schematic Diagrams shown in Section 5.

**SECTION 4. LIST OF REPLACEABLE PARTS**

Includes parts lists for all standard assemblies. Information on how and where to order parts is also provided.

**SECTION 5. SCHEMATIC DIAGRAMS**

Includes schematic diagrams for all assemblies.



## CONVENTIONS

1-3.

Throughout the manual, certain notational conventions are used. A summary of these conventions follows:

- Instrument Reference

When the discussion involves common features of the Fluke model 70, 73, 75, 77, 21, and 23 multimeters, the term "meter" is used. Where features differ among models, further identification is made by model number.

- Printed Circuit Assembly

The term "pca" is used to represent a printed wiring board and its attached parts.

- Circuit Nodes

Individual pins or connections on a component are specified by a dash (-) following the component reference designator. For example, pin 19 of U30 would be U30-19.

- User Notation

Generally, push buttons, function positions, input terminals, and display notation are presented in this manual as they are seen on the meter.

Special terms (mnemonics) used in text descriptions of meter circuitry correspond to terms used on the schematic diagrams in Section 5.

## SPECIFICATIONS

1-4.

Specifications for the meters are presented in Table 1-1.

Table 1-1. Specifications

Maximum Voltage Between any Terminal and Earth Ground	1000V dc, 750V ac rms (sine)
Fuse Protection	300 mA: 630 mA, 250V Fast Fuse 10A: 15A, 600V FAST Fuse
Display	Digital: 3,200 counts, updates 2.5/sec Analog: 32 segments, updates 25/sec
Response Time of Digital Display to Rated Accuracy	V ac < 2 s V dc < 1 s $\Omega$ < 1 s to 320 k $\Omega$ , < 2 s to 3.2 M $\Omega$ , < 10 s to 32 M
Operating Temperature	0°C to 50°C
Storage Temperature	-40°C to 60°C
Temperature Coefficient	0.1 x (specified accuracy)/°C (<18°C or >28°C)
Relative Humidity	0% to 90% (0°C to 35°C)
Except 32 M $\Omega$ Range:	0% to 70% (35°C to 50°C)
32 M $\Omega$ Range Only:	0% to 80% (0°C to 35°C) 0% to 70% (35°C to 50°C)
Battery Type	9V, NEDA 1604 or 6F22 or 006P
Battery Life	2000 hrs typical with alkaline 1600 hrs typical with carbon zinc
Continuity Beeper	4096 Hz
Shock, Vibration	Per MIL-T-28800 for a Style B, Class 2 Instrument
Size (HxWxL)	2.8 cm x 7.5 cm x 16.6 cm (1.12 in x 2.95 in x 6.55 in)
Weight	340g (12 oz)
Safety	Designed to Protection Class II per IEC 348, ANSI/ISA-S82, UL1244, and CSA C22.2 No.231

Table 1-1. Specifications (cont)

FUNCTION	RANGE	RESOLUTION	ACCURACY	BURDEN VOLTAGE (TYPICAL)
VAC (45-500 Hz, 3.2V rmg Other ranges 45-1kHz)	3.200V 32.00V 320.0V 750V	0.001V 0.01V 0.1V 1V	$\pm(2\%+2)$ $\pm(2\%+2)$ $\pm(2\%+2)$ $\pm(2\%+2)$	Not Applicable
$\Omega$	320.0 $\Omega$ 3200 $\Omega$ 32.00 k $\Omega$ 320.0 k $\Omega$ 3.200 M $\Omega$ 32.00 M $\Omega$	0.1 $\Omega$ 1 $\Omega$ 0.01 k $\Omega$ 0.1 k $\Omega$ 0.001 M $\Omega$ 0.01 M $\Omega$	$\pm(0.5\%+2)$ $\pm(0.5\%+1)$ $\pm(0.5\%+1)$ $\pm(0.5\%+1)$ $\pm(0.5\%+1)$ $\pm(2\%+1)$	Not Applicable
$\rightarrow \vdash \text{ III}$ )	2.0V	0.001V	$\pm(1\%$ Typical)	Not Applicable
AAC* (45 Hz to 1 kHz)	32.00 mA** 320 mA** 10.00 A***	0.01 mA 0.1 mA 0.01A	$\pm(2.5\%+2)$ $\pm(2.5\%+2)$ $\pm(2.5\%+2)$	6 mV/mA 6 mV/mA 50 mV/A
ADC*	32.00 mA** 320 mA** 10.00 A***	0.01 mA 0.1 mA 0.01A	$\pm(1.5\%+2)$ $\pm(1.5\%+2)$ $\pm(1.5\%+2)$	6 mV/mA 6 mV/mA 50 mV/A
<p>* Current function not available on Fluke 70  ** Ranges available on Fluke 75/21 and 77/23 only.  *** 10A continuous, 20A for 30 seconds maximum</p>				

FUNCTION	RANGE	RESOLUTION	ACCURACY		
			70	73/75/21	77/23
VDC	3.200V	0.001V	$\pm(0.5\%+1)$	$\pm(0.4\%+1)$	$\pm(0.3\%+1)$
	32.00V	0.01V	$\pm(0.5\%+1)$	$\pm(0.4\%+1)$	$\pm(0.3\%+1)$
	320.0V	0.1V	$\pm(0.5\%+1)$	$\pm(0.4\%+1)$	$\pm(0.3\%+1)$
	1000V	1V	$\pm(0.6\%+1)$	$\pm(0.4\%+1)$	$\pm(0.4\%+1)$
mVDC	320mV	0.1mV	$\pm(0.5\%+1)$	$\pm(0.4\%+1)$	$\pm(0.3\%+1)$

Table 1-1. Specifications (cont)

FUNCTION	OVERLOAD PROTECTION	INPUT IMPEDANCE (NOMINAL)	COMMON MODE REJECTION RATIO (1-KΩ UNBALANCE)		NORMAL MODE REJECTION
VDC	1000V dc 750V ac rms (sine)	>10 MΩ, <50 pF	>120 dB at dc, 50 Hz, or 60 Hz		>60 dB at 50 Hz or 60 Hz
mVDC	500V dc 500V ac rms (sine)	>10 MΩ, <50 pF	>120 dB at dc, 50 Hz, or 60 Hz		>60 dB at 50 Hz or 60 Hz
VAC	1000V dc 750V ac rms (sine)	>10 MΩ, <50 pF (ac-coupled)	>60 dB, dc to 60 Hz		
Ω	500V dc 500V ac rms (sine)	Open Circuit Test Voltage	Full Scale Voltage		Short Circuit Current
			To 3.2 MΩ	32 MΩ	
		<3.1V dc <2.8V dc (typical)	<440 mVdc <420 mV (typical)	<1.4V dc <1.3V dc (typical)	500 μA (typical)
	500V dc 500V ac rms (sine)	<3.1V dc	2.0V dc	--	700 μA (typical)
		Typical Test Current		V <sub>F</sub>	
		0.7 mA	0.0V		
		0.5mA	0.6V		
		0.3 mA	1.2V		
		0.1 mA	2.0V		

# Section 2 Theory of Operation

## CONTENTS

	PAGE
2-1. INTRODUCTION .....	2-3
2-2. FUNCTIONAL BLOCK DESCRIPTION .....	2-3
2-3. DETAILED DESCRIPTION .....	2-3
2-4. Voltage Signal Conditioning .....	2-3
2-5. Current Conditioning .....	2-4
2-6. Ohms .....	2-4
2-7. Additional Circuitry .....	2-4
2-8. AC CONVERTER .....	2-4
2-9. ACTIVE FILTER .....	2-4
2-10. ROTARY SWITCH .....	2-5
2-11. A/D CONVERSION .....	2-5

**INTRODUCTION**

2-1.

This section contains a brief overview of the 70, 73, 75, 77, 21, and 23 Series II Multimeters, followed by a more detailed explanation of operation.

**FUNCTIONAL BLOCK DESCRIPTION**

2-2.

The heart of the instrument consists of a two-chip CMOS system: U1, a primarily analog IC, and U2, a calculator-style microcomputer (see Figure 2-1).

The analog chip, U1, contains the a/d converter, active filter, ac converter, analog signal routing, range switching, and power supply functions. Peripherals to U1 include function switching, voltage reference, and the crystal.

The microcomputer, U2, controls the a/d converter function and range switching, reads and formats the a/d samples, and drives the liquid crystal display (LCD).

**DETAILED DESCRIPTION**

2-3.

The following paragraphs describe the 70, 73, 75, 77, 21 and 23 Series II multimeters in more detail. While reading this description, refer to the schematic diagram in Section 5.

**Voltage Signal Conditioning**

2-4.

Input divider Z1 and dc blocking capacitor C1 make up an input voltage signal conditioning circuit.

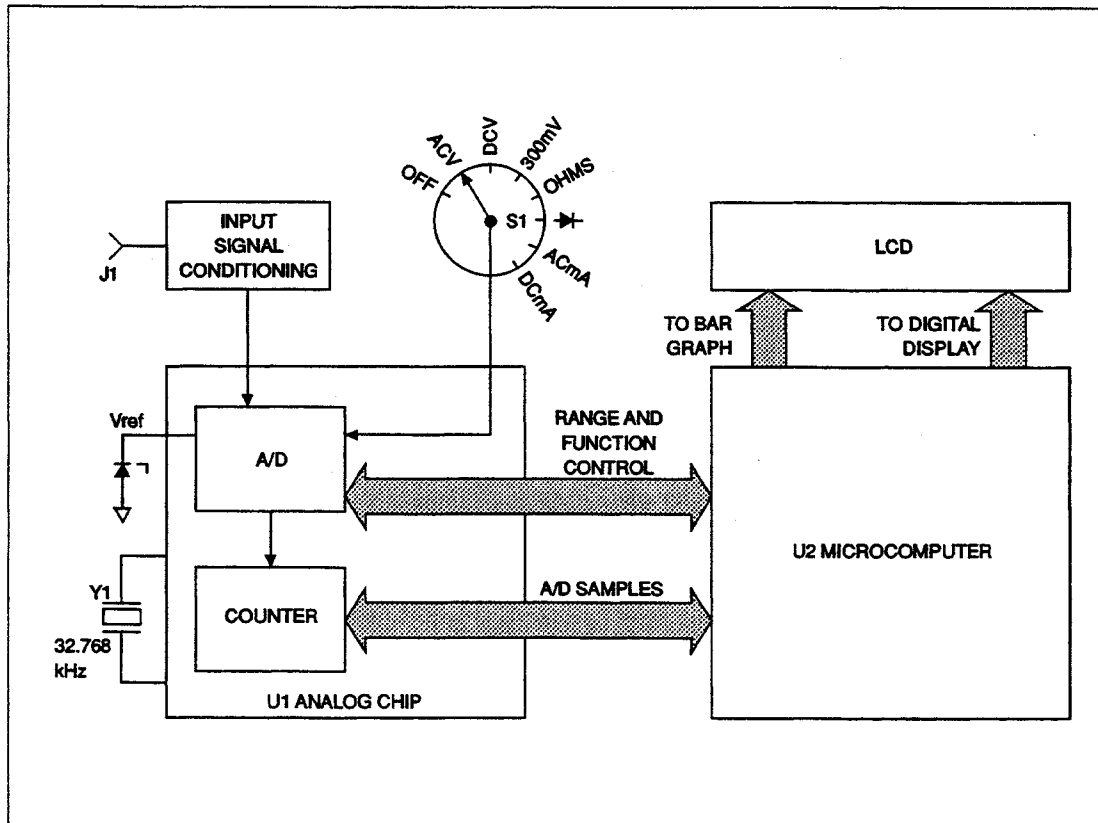

Figure 2-1. Overview

## Theory of Operation

### DETAILED DESCRIPTION

---

The pins of Z1 are used as follows:

Z1-PIN NUMBER	FUNCTION
1	input
3	3.2V range tap
4	32V range tap
5	320V range tap
6	1000V dc/750V ac range tap

Overvoltage protection is provided by E1, R1, R2, RV1, and RV2.

E1 is a spark gap that fires between 1200V and 1800V. R1 is a fusible resistor that opens with excessive inputs. RV1 and RV2 are metal-oxide varistors that clamp around 910V each.

#### Current Conditioning

2-5.

Current input conditioning is provided by R6, R7, R5, and R13. R6 and R7 develop input voltage from the applied current. R5 and R13 act as a voltage divider for the 300-mA range. F1 protects the mA circuitry; F3 protects the 10A circuitry. (Model 70 has no current-measuring capability; Model 73 measures current only on the 10A range.)

#### Ohms

2-6.

When the ohms function is selected, the meter compares the unknown resistance at J1 with the reference resistors in Z1. (See Figure 2-2, Ohms Function.)

Input protection for the ohms ranges consists of Q1, Q2, Q3, R2, R3, R4, and RT1. Q1 and Q2 serve as back-to-back zener diodes which limit the input to between 7 and 9V. RT1 is a thermistor that normally has about 1 k $\Omega$  of resistance but increases to very high impedance as it heats up with an overload voltage. Also, R2, R3, and R4 limit current, and Q3 clamps pin 29 of U1 to approximately 2.5V.

#### Additional Circuitry

2-7.

In addition to the above circuitry, the following circuitry is also used in the Series II meters: AC Converter, Active Filter, Rotary Switch, and A/D Conversion.

#### AC CONVERTER

2-8.

The ratio of R17 and R18 determines ac voltage and current accuracy (see Figure 2-3, AC and A/D Converter), and C11 is the averaging capacitor for the half-wave ac converter portion of U1.

#### ACTIVE FILTER

2-9.

An active filter that includes R9, R10, C5, and C6 is located in U1. Conditioned input signals are passed through the active filter in route to the a/d converter section of U1. (See Figure 2-3, AC and A/D Converter.)

The clock frequency for the digital portion of the circuit is a function of 32.768-kHz crystal Y1. Y1, C12, C15, and amplifiers in U1 make up the oscillator circuit.

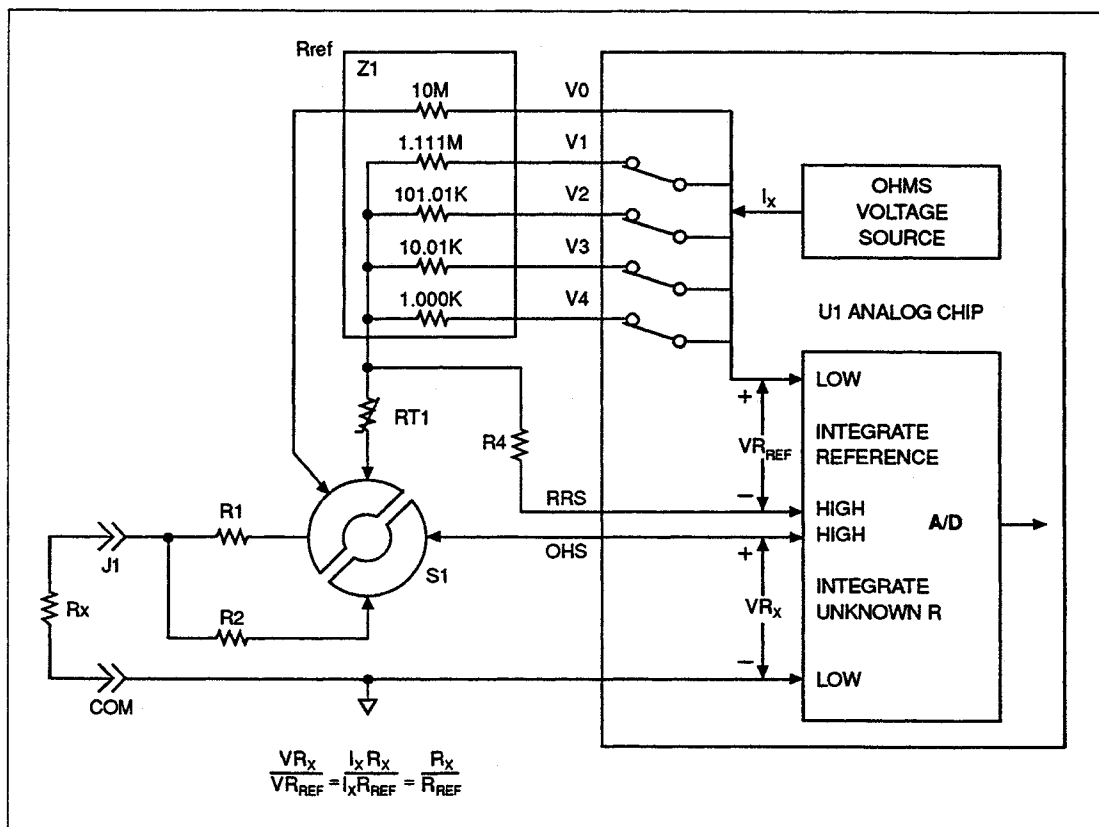

Figure 2-2. Ohms Function

### ROTARY SWITCH

2-10.

Rotary switch S1 FRONT selects and routes the input signals. Function codes for switch S1 REAR are shown in Table 2-1. Range switch S2 signals the microcomputer U2 for the manual ranging and automatic Touch Hold<sup>®</sup> function.

CR1 acts as protection for U1 if the battery is installed backwards. C2 is part of the power-on reset for microcomputer U2.

### A/D CONVERSION

2-11.

Analog-to-digital (a/d) conversion is accomplished within U1 using a modified dual-slope a/d converter circuit. (See Figure 2-3, AC and A/D Converter.)

Since the a/d conversion process is essentially a dual slope method, two voltages are required to complete a measurement cycle. One is the unknown input and the other is the reference voltage.

Conditioned input signals are routed to the a/d converter in U1, where they are integrated. The reference voltage developed by reference supply VR1, R15, R16, and R8 is routed to the a/d converter in U1, where it is used for the integrate reference (de-integrate) portions of the measurement cycle.

C7 stores offsets of the buffer, integrator, and comparator amplifiers of the a/d converter. The gain of the buffer is determined by the resistors of Z1 between pins 8, 9, and 10. C8 is the integrator capacitor.

<sup>®</sup> Touch Hold is a registered trademark of the John Fluke Mfg. Co., Inc.



## Theory of Operation

### DETAILED DESCRIPTION

---

A series of 10 minor cycle conversions occurs without taking time for an autozero phase between the conversions. These minor cycle conversions, or samples, occur at a rate of 25 per second, and are used to provide the fast response bar-graph display and fast autoranging.

New samples are taken every 40 ms. Ten samples are summed to produce a full-resolution digital display, with full scale greater than 3200 counts. A 50-ms autozero phase occurs following every 10 sample sequence.

**Table 2-1. S1 Function Codes**

<b>FUNCTION</b>	<b>B0</b>	<b>B1</b>	<b>B2</b>
ACV	1	1	1
DCV	0	1	1
300 mV	0	0	0
Ohms	0	0	1
	1	0	0
ACA	1	1	0
DCA	0	1	0

1 = VDD  
0 = (common)

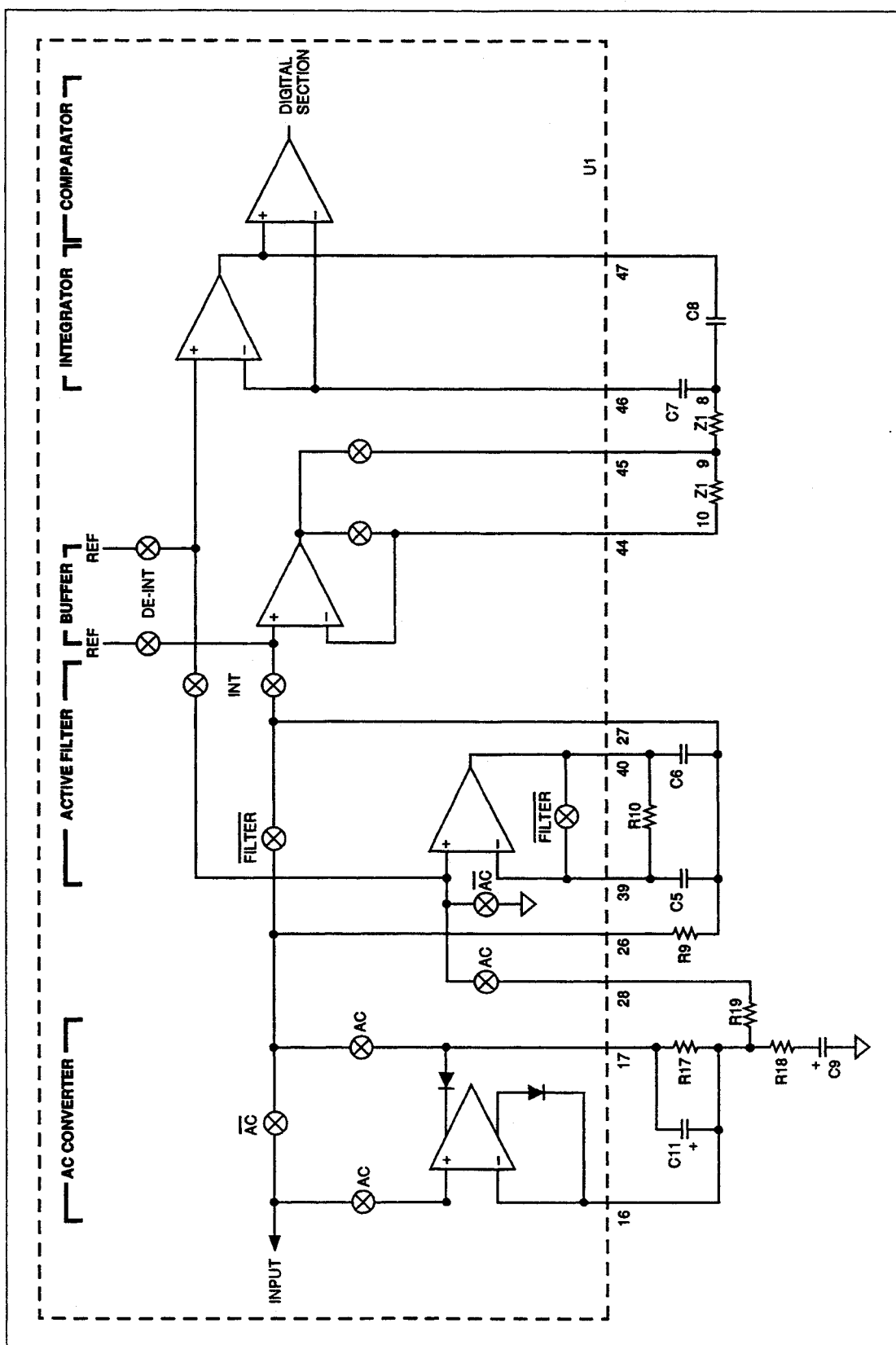

Figure 2-3. AC and A/D Converter



# static awareness



A Message From  
Fluke Corporation

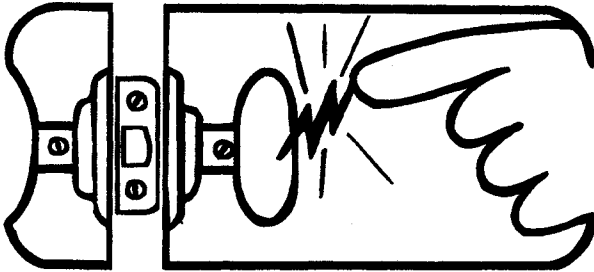

Some semiconductors and custom IC's can be damaged by electrostatic discharge during handling. This notice explains how you can minimize the chances of destroying such devices by:

1. Knowing that there is a problem.
2. Learning the guidelines for handling them.
3. Using the procedures, packaging, and bench techniques that are recommended.

The following practices should be followed to minimize damage to S.S. (static sensitive) devices.

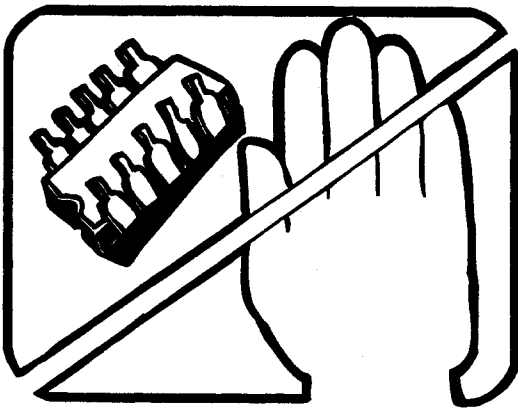

1. MINIMIZE HANDLING

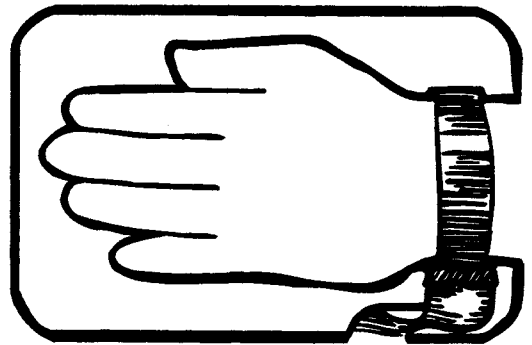

3. DISCHARGE PERSONAL STATIC BEFORE HANDLING DEVICES. USE A HIGH RESISTANCE GROUNDING WRIST STRAP.

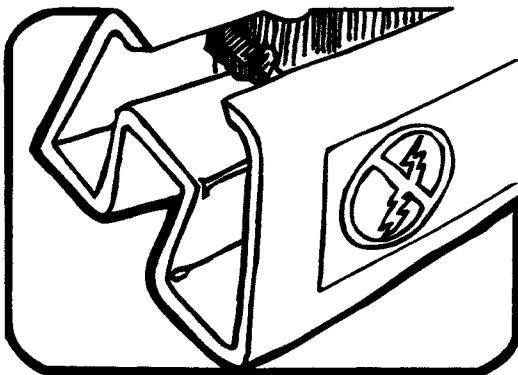

2. KEEP PARTS IN ORIGINAL CONTAINERS UNTIL READY FOR USE.

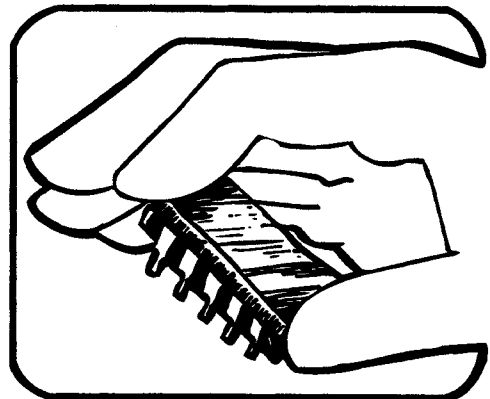

4. HANDLE S.S. DEVICES BY THE BODY.

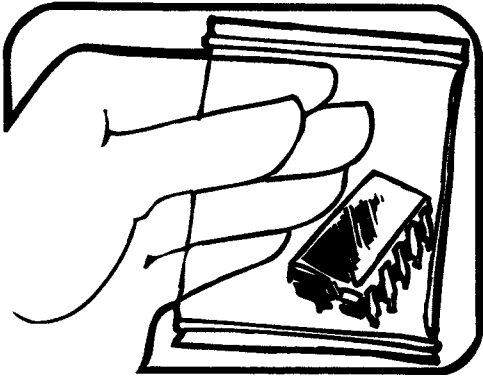

5. USE STATIC SHIELDING CONTAINERS FOR HANDLING AND TRANSPORT.

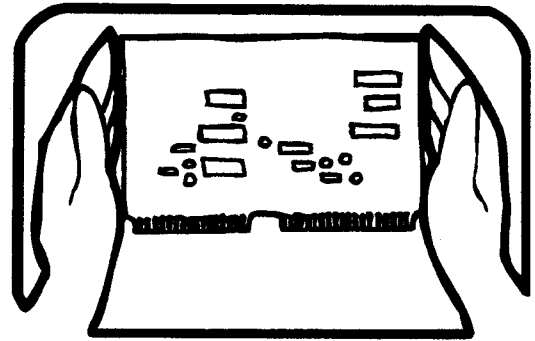

8. WHEN REMOVING PLUG-IN ASSEMBLIES HANDLE ONLY BY NON-CONDUCTIVE EDGES AND NEVER TOUCH OPEN EDGE CONNECTOR EXCEPT AT STATIC-FREE WORK STATION. PLACING SHORTING STRIPS ON EDGE CONNECTOR HELPS PROTECT INSTALLED S.S. DEVICES.

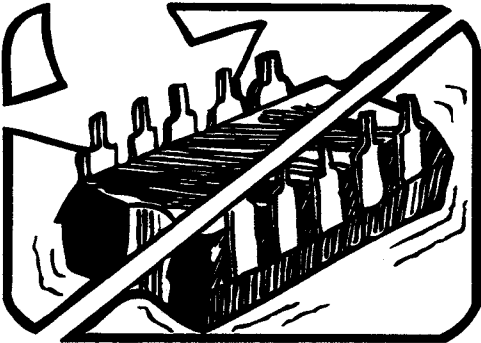

6. DO NOT SLIDE S.S. DEVICES OVER ANY SURFACE.

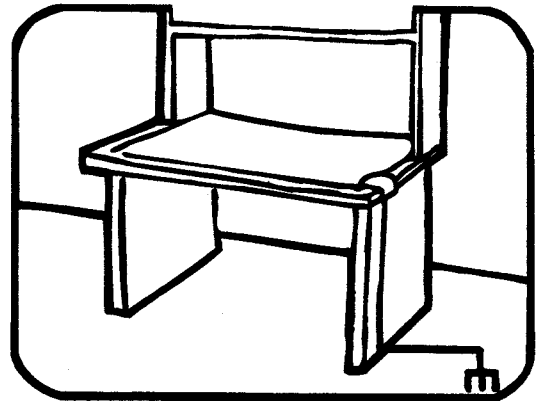

9. HANDLE S.S. DEVICES ONLY AT A STATIC-FREE WORK STATION.

10. ONLY ANTI-STATIC TYPE SOLDER-SUCKERS SHOULD BE USED.

11. ONLY GROUNDED-TIP SOLDERING IRONS SHOULD BE USED.

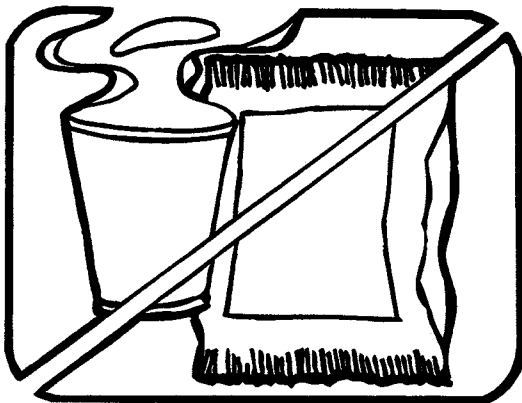

7. AVOID PLASTIC, VINYL AND STYROFOAM® IN WORK AREA.

PORTIONS REPRINTED  
WITH PERMISSION FROM TEKTRONIX INC.  
AND GENERAL DYNAMICS, POMONA DIV.

# Section 3 Maintenance

## CONTENTS

	PAGE
3-1. INTRODUCTION .....	3-2
3-2. PCA ACCESS AND GENERAL MAINTENANCE .....	3-2
3-3. DISPLAY ACCESS .....	3-4
3-4. CLEANING .....	3-4
3-5. PERFORMANCE TESTS .....	3-5
3-6.     Initial Procedure .....	3-5
3-7.     Display Test .....	3-5
3-8.     DC Voltage Test .....	3-5
3-9.     AC Voltage Test .....	3-6
3-10.    Resistance Test .....	3-6
3-11.    Diode Test .....	3-7
3-12.    DC mA Test (75/21 & 77/23 Only) .....	3-8
3-13.    DC Amps Test (73, 75/21, and 77/23 Only) .....	3-8
3-14. CALIBRATION .....	3-8
3-15. TROUBLESHOOTING .....	3-8
3-16.    Supplemental Troubleshooting Procedures .....	3-11
3-17.    CHECKING THE CRYSTAL OSCILLATOR .....	3-11
3-18.    CHECKING THE REFERENCE VOLTAGE .....	3-11
3-19.    CHECKING DISPLAY DRIVE VOLTAGE .....	3-11
3-20.    CHECKING BEEPER DRIVE SIGNAL .....	3-11
3-21.    TRACING THE VDC SIGNAL PATH .....	3-11

**WARNING**

**THESE SERVICE INSTRUCTIONS ARE FOR USE BY QUALIFIED PERSONNEL ONLY. TO AVOID ELECTRIC SHOCK, DO NOT PERFORM ANY SERVICING OTHER THAN THAT CONTAINED IN THE OPERATOR'S MANUAL UNLESS YOU ARE QUALIFIED TO DO SO.**

**INTRODUCTION****3-1.**

This section contains maintenance information for the performance testing, calibration, general maintenance, and troubleshooting of the 70, 73, 75, 77, 21, and 23 Series II Multimeters (collectively called the Series II meters). For operator maintenance and instrument specifications, refer to the Users Manual.

The performance tests are recommended as a preventive maintenance tool to verify proper instrument operation. A one year calibration cycle is recommended to maintain the specifications given in the Users Manual. Test equipment required for the performance tests and calibration is listed in Table 3-1. If the recommended equipment is not available, instruments with equivalent specifications may be used.

**PCA ACCESS AND GENERAL MAINTENANCE****3-2.****WARNING**

**TO AVOID ELECTRICAL SHOCK, REMOVE THE TEST LEADS BEFORE OPENING THE CASE, AND CLOSE THE CASE BEFORE OPERATING THE METER. TO PREVENT FIRE, INSTALL FUSES WITH THE RATING SHOWN ON BACK OF THE METER.**

**CAUTION**

**To avoid contaminating the pca with oil from the fingers, handle it by the edges or wear gloves. PCA contamination may not cause immediate instrument failure in controlled environments. Failures typically show up when contaminated units are operated in humid areas.**

Use the following procedure for removing the pca (printed circuit assembly) from its case:

1. Set the function switch to OFF, and disconnect test leads if they are installed.
2. Remove the four Phillips screws from the bottom cover.
3. Turn the meter face up, grasp the top cover, and pull the top cover from the meter.
4. Some Series II meters have a fuse on the lower portion of the pca. This fuse must be removed to access the screw that holds the pca to the case bottom.

**NOTE**

*Be careful not to lose the spring located directly under the screw on the back side of the pca.*

5. The pca may now be removed from the bottom cover.

Table 3-1. Recommended Test Equipment

INSTRUMENT TYPE	REQUIRED CHARACTERISTICS	RECOMMENDED MODEL
<b>PREFERRED</b>		
DMM Calibrator	John Fluke 5100B Family	John Fluke Models 5100B, 5101B, 5102B, 5700A
<b>ALTERNATE</b>		
DCV Calibrator	DC Voltage Range: 0 to 1000V Accuracy: $\pm .05\%$	
ACV Calibrator	AC Voltage Range: 0 to 750V Accuracy: $\pm 0.4\%$	
Current Calibrator	Frequency Range: 40 Hz to 1 kHz DC mA: 0 to 300 mA DCA: 0 to 2A Accuracy: 0.3%	
Decade Resistor	Resistance: 0 to 30 M $\Omega$ Accuracy: $\pm .1\%$ Resistance: 0 to 10 M $\Omega$ Accuracy: 0.1%	
		General Resistance RDS-77B ESI DB-62

**DISPLAY ACCESS**

**3-3.**

**CAUTION**

**Do not handle the conductive edges of the LCD interconnects. If contaminated, clean with alcohol.**

Refer to Figure 3-1.

1. Remove the four Phillips screws from the back side of the pca.
2. Remove the LCD mounting bracket.
3. Insert a small screwdriver under the edges of the display holding bracket, and gently pry the bracket loose from the snaps.
4. Turn the bracket upside down to remove the LCD.
5. Before installing a new LCD, make sure that all connector contact points are clean.

**CLEANING**

**3-4.**

**CAUTION**

**To avoid damaging the meter, do not use aromatic hydrocarbons or chlorinated solvents for cleaning. These solutions will react with the plastics used in the instruments.**

**Do not allow the LCD to get wet. Remove the display assembly before washing the pca and do not install until the pca is completely dry.**

**Do not use detergent of any kind for cleaning the pca.**

**Do not remove lubricants from the switch when cleaning the pca.**

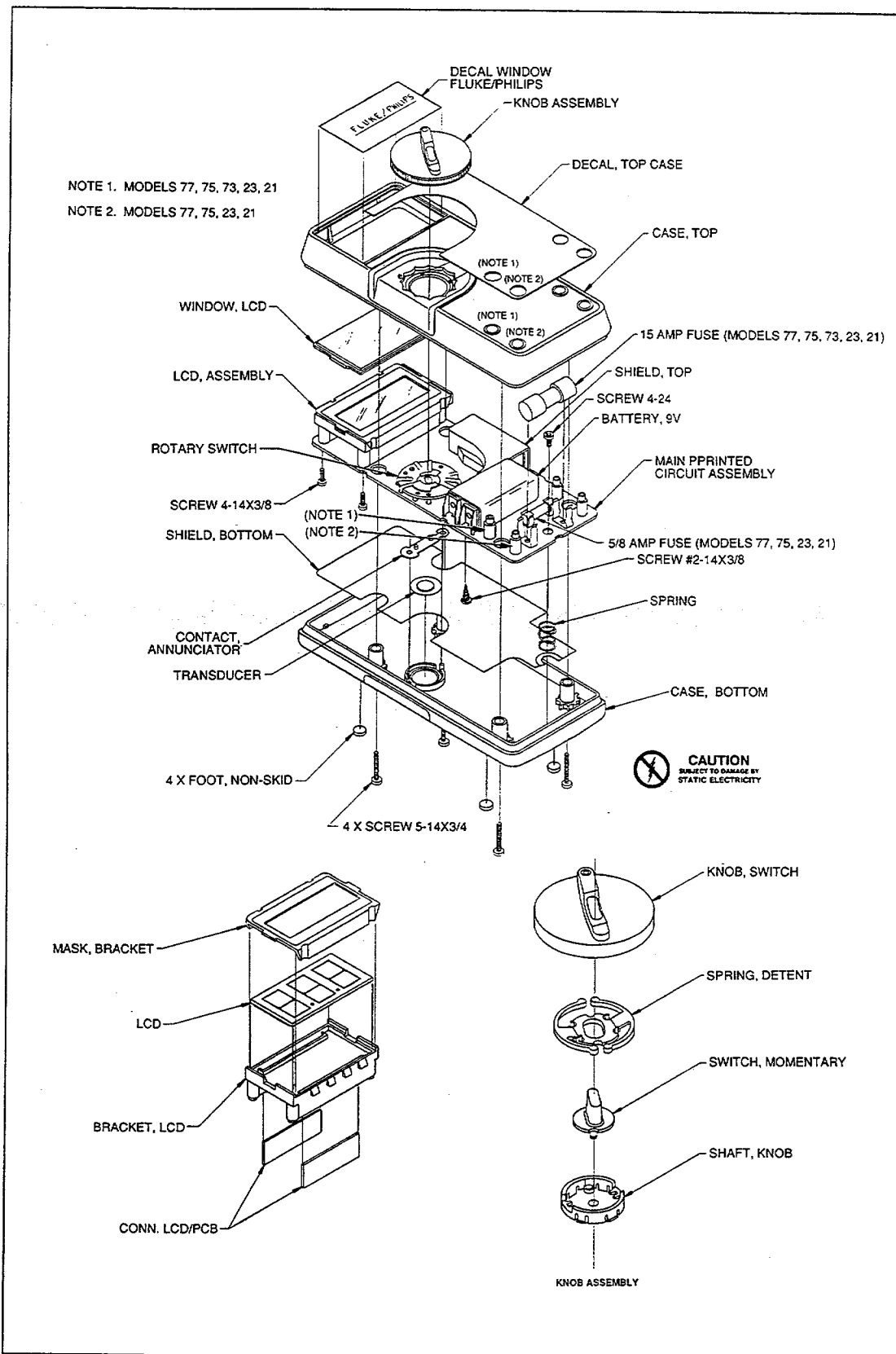

Figure 3-1. Assembly Details



Clean the instrument case with a mild detergent and water.

The pca may be washed with isopropyl alcohol or deionized water and a soft brush. Remove the display assembly and fuses before washing, and avoid washing the switch if possible. Dry the pca with clean dry air at low pressure, then bake it at 50°C for 24 hours.

### PERFORMANCE TESTS

3-5.

Performance tests are recommended for incoming inspection, periodic maintenance, and for verifying the specifications in the Users Manual. If the instrument fails any part of the test, calibration and/or repair is indicated.

In the performance tests, the Fluke Series II meters are referred to as the unit under test (UUT).

### Initial Procedure

3-6.

1. Allow the UUT to stabilize to room temperature  $23^{\circ}\text{C} \pm 5^{\circ}\text{C}$  ( $73^{\circ}\text{F} \pm 9^{\circ}\text{F}$ ).
2. Check the fuses and battery, and replace them if necessary.

### WARNING

**TO PREVENT FIRE, INSTALL FUSES IN ACCORDANCE WITH THE RATING SHOWN ON THE BACK OF THE METER.**

### Display Test

3-7.

To test the display, turn the UUT on and check whether all display segments come on as indicated in Figure 3-2.

### DC Voltage Test

3-8.

### WARNING

**CONNECT THE GROUND/COMMON/LOW SIDE OF THE DC CALIBRATOR TO COM ON THE UUT.**

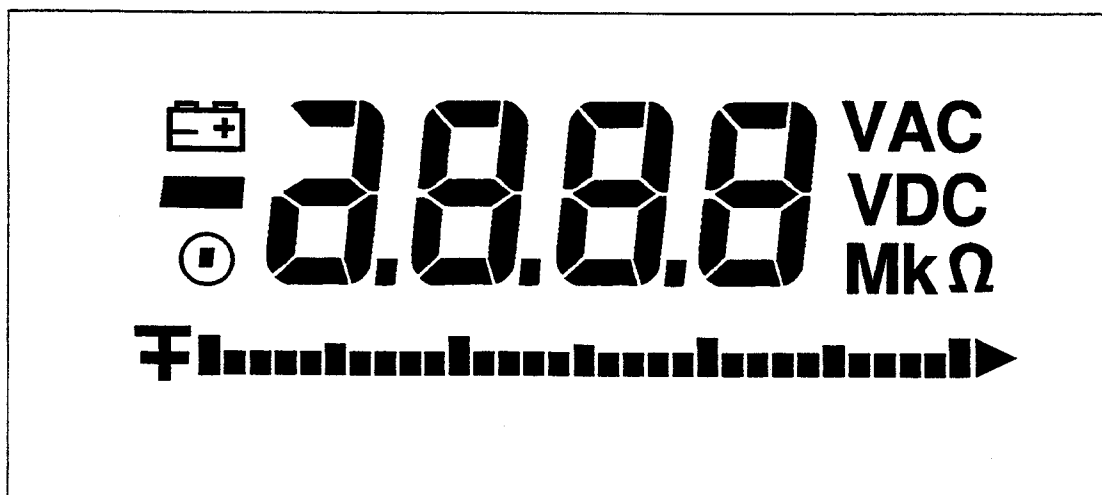

Figure 3-2. Display

1. Set the UUT function switch to VDC, and connect the DC Voltage Calibrator output to the  $\nu\Omega\rightarrow$  and COM input terminals of the UUT.
2. Referring to Table 3-2, set the DC Voltage Calibrator for the output indicated in steps 1 through 4 only. Verify that the UUT display reading is within the limits shown.

Table 3-2. DC Voltage Test

STEP	DC INPUT VOLTAGE	DISPLAY READING		
		70	73/75/21	77/23
1	+2.7V	2.685 to 2.715	2.688 to 2.712	2.691 to 2.709 V DC
2	+27V	26.85 to 27.15	26.88 to 27.12	26.91 to 27.09 V DC
3	+270V	268.5 to 271.5	268.8 to 271.2	269.1 to 270.9 V DC
4	+1000V	993 to 1007	995 to 1005	995 to 1005 V DC
*5	+300 mV	298.4 to 301.6	298.7 to 301.3	299.0 to 301.0 V DC
*300 mV function only				

3. Set the DC Voltage Calibrator for an output of +300 mV, and switch the UUT to the 300 mV function. Verify that the UUT display reading is within the limits shown in Table 3-2 (step 5).

AC Voltage Test

3-9.

**WARNING**

**CONNECT THE GROUND/COMMON/LOW SIDE OF THE AC CALIBRATOR TO COM ON THE UUT.**

1. Set the UUT function switch to VAC, and connect the AC Voltage Calibrator to the  $\nu\Omega\rightarrow$  and COM input terminals.
2. Set the AC Voltage Calibrator for the output given in Table 3-3, and verify that the UUT display reading is within the limits shown.

*NOTE*

*When the input is open in the VAC function, it is normal for the 70 Series II meters to read some counts on the display. This is due to ac pickup in the ac amplifier when the ac amplifier is unterminated.*

Table 3-3. AC Voltage Test

STEP	INPUT		DISPLAY READING 70, 73, 75/21 and 77/23
	VOLTAGE	FREQ.	
1	2.7V	100 Hz	2.644 to 2.756 V AC
2	2.7V	500 Hz	2.644 to 2.756 V AC
3	750V	100 Hz	733 to 767 V AC
4	750V	1000 Hz	733 to 767 V AC

**Resistance Test**

**3-10.**

1. Select the ohms function on the UUT.
2. Connect the Ohms Calibrator or Decade Resistor to the  $V\Omega \rightarrow$  and COM input terminals of the UUT.
3. Referring to Table 3-4, set the Ohms Calibrator or Decade Resistor to the resistance value indicated in steps 1 through 6. Verify that the display reading is within the limits shown.

**Table 3-4. Resistance Test**

STEP	INPUT RESISTANCE	DISPLAY READING
1	short	0.0 to 0.2 $\Omega$
Decades of 1:		
2	100 $\Omega$	99.3 to 100.7 $\Omega$ (plus 0 reading)
3	1 k $\Omega$	994 to 1006 $\Omega$
4	10 k $\Omega$	9.994 to 10.06 k $\Omega$
5	100 k $\Omega$	99.94 to 100.6 k $\Omega$
6	1 M $\Omega$	.994 to 1.006 M $\Omega$
7	10 M $\Omega$	9.79 to 10.21 M $\Omega$
Decades of 1.9:		
2	190 $\Omega$	188.8 to 191.2 $\Omega$ (plus 0 reading)
3	1.9 k $\Omega$	1889 to 1911 $\Omega$
4	19 k $\Omega$	18.89 to 19.11 k $\Omega$
5	190 k $\Omega$	188.9 to 191.1 k $\Omega$
6	1.9 M $\Omega$	1.889 to 1.911 M $\Omega$
7	19 M $\Omega$	18.61 to 19.39 M $\Omega$
Decades of 2.7:		
2	270 $\Omega$	268.4 to 271.6 $\Omega$ (plus 0 reading)
3	2.7 k $\Omega$	2685 to 2715 $\Omega$
4	27 k $\Omega$	26.85 to 27.15 k $\Omega$
5	270 k $\Omega$	268.5 to 271.5 k $\Omega$
6	2.7 M $\Omega$	2.685 to 2.715 M $\Omega$
7	27 M $\Omega$	26.45 to 27.55 M $\Omega$

**Diode Test**

**3-11.**

To test the Series II meters, perform the following steps:

1. Set the UUT to the Diode Test function.

*NOTE*

*On Fluke 5100 series calibrators, activate the 50 $\Omega$  divider override.*

2. Apply an input from the DC Voltage Calibrator of +.090V dc to the  $V\Omega \rightarrow$  and COM input terminals of the UUT, and verify that the beeper is on.
3. Increase the DC Voltage Calibrator output to +.110V dc, and verify that the beeper is off.

**DC mA Test (75/21 & 77/23 Only)**

**3-12.**

1. Set the output of the DC Current Calibrator to zero, and connect it to the 300mA and COM input terminals of the UUT.
2. Set the DC Current Calibrator to the output shown in Table 3-5, and verify that the UUT display reading is within the limits shown.

**Table 3-5. DC mA Test**

STEP	INPUT CURRENT	DISPLAY READING 75/21 & 77/23
1	+27 mA	26.57 to 27.43 DC
2	+200 mA	196.8 to 203.2 DC

**DC Amps Test (73, 75/21, and 77/23 Only)**

**3-13.**

1. Set the DC Current Calibrator to standby and connect it to the 10A and COM input terminals of the UUT.
2. Apply currents as indicated in Table 3-6, and verify that the display reading is within the limits shown.

**Table 3-6. DC Amps Test**

STEP	INPUT CURRENT (5100B)	DISPLAY READING
1	+1.99999A dc	1.95 to 2.05 DC

**CALIBRATION**

**3-14.**

1. Set the DC Voltage Calibrator to zero, and set the UUT to the VDC function.
2. Remove the case top cover as previously described.
3. Connect the DC Voltage Calibrator to the  $v_{n-}$  and COM input terminals of the UUT.
4. Set the DC Voltage Calibrator for an output of +3.000V dc, and adjust R8 for a display reading of +3.000V dc  $\pm$  .001V.

**TROUBLESHOOTING**

**3-15.**

A troubleshooting tree for the Series II meters is given in Figure 3-3. Faults are listed in the order of probability. This tree gives a systematic approach to isolation of problems to a component or component area. Complete the procedures in the order listed in this table; all measurements are made with respect to common.

Also, supplemental troubleshooting procedures are presented in the following paragraphs.

When troubleshooting the 70 Series II meters, use the precautions listed on the static awareness sheet to prevent damage from static discharge.



**Supplemental Troubleshooting Procedures** 3-16.

**CHECKING THE CRYSTAL OSCILLATOR** 3-17.

Connect an oscilloscope or counter to pin 54 of U1 or to the junction of C12 and the Y1 crystal. Check for a 32.768-kHz sine wave approximately 600 mV p-p in amplitude. Note that U2 and the display will not work if the clock circuit is not working.

Probable related failures include: U1, Y1, or C12.

**CHECKING THE REFERENCE VOLTAGE** 3-18.

Check for a reference voltage of 1.00V dc (adjustable by R8) at pin 14 of U1 or at the junction of R15 and R16.

Probable related failures include: R8, R14, R15, R16, VR1, or CR2.

**CHECKING DISPLAY DRIVE VOLTAGE** 3-19.

Check that VM (V middle) is 1.6V dc  $\pm$  .1V at pin 28 of U2 or at the junction of R11 and R12.

Probable related failures include: R11 or R12.

**CHECKING BEEPER DRIVE SIGNAL** 3-20.

Put the unit in the Diode Test Mode and short the input leads. Using an oscilloscope, measure the signal at pin 3 of U1. The signal should be a 4V p-p symmetrical square wave at about 4.1 kHz.

A probable related failure is: U1.

**TRACING THE VDC SIGNAL PATH** 3-21.

Use the following procedure to trace the VDC signal path:

1. Set the UUT to the VDC function and apply 2V dc to the input.
2. Using a DVM, measure the input at J1 for 2V dc.
3. Measure pin 1 of Z1 input divider for 2V dc. Probable related failures include: R1, S1, RV1, or RV2.

**NOTE**

*Measurements in steps 4, 5, and 6 may be affected by loading.*

4. Measure Z1 pin 3 for 200 mV dc. Probable related failures are: Z1, U1.
5. Measure for 200 mV dc at the active filter input (AFI, pin 26 of U1 or R9). A probable failure is: U1.
6. Measure for 200 mV at the active filter output (AFO, pin 27 of U1 or R9). Probable related failures are: R9, C5, or C6.

**WARNING**

**R1 IS A FUSIBLE RESISTOR. TO ENSURE SAFETY, USE EXACT REPLACEMENT ONLY.**

# Section 4

## List of Replaceable Parts

### CONTENTS

TITLE	DRAWING NUMBER	TABLE NO.	PAGE NO.	FIGURE NO.	PAGE NO.
Final Assembly (77,75,23,21)	FLUKE-77-2 T&B	4-1	4-5	4-1	4-6
A1 Main PCA (77,75,23,21)	FLUKE-77-2-4021	4-2	4-8	4-2	4-9
Final Assembly (73)	FLUKE-73-2-T&B	4-3	4-10	4-3	4-11
A1 Main PCA (73)	FLUKE-73-2-4021	4-4	4-13	4-4	4-14
Final Assembly (70)	FLUKE-70-2-T&B	4-5	4-15	4-5	4-16
A1 Main PCA (70)	FLUKE-70-2-4021	4-6	4-18	4-6	4-19

## INTRODUCTION

4-1.

Parts are listed alphanumerically by reference designator or item number. Each part is shown in an accompanying illustration unless otherwise noted.

Parts lists include the following information:

- Reference designation or item number
- Description of each part
- Fluke part number
- Manufacturer's supply code
- Manufacturer's part number
- Total quantity of components per assembly

## HOW TO OBTAIN PARTS

4-2.

Use the Fluke Stock Number when ordering all components from the John Fluke Mfg. Co., Inc. or an authorized representative. In the U.S., order directly from the Fluke Parts Department by calling 1-800-526-4731.

Some components may be ordered directly from the manufacturer using the manufacturer's part number.

In the event the part your order has been replaced by a new or improved part, the replacement will be accompanied by an explanatory note and installation instructions, if necessary.

To ensure prompt and efficient handling of your order, include the following information:

1. Instrument model and serial number
2. Fluke stock number
3. Description of part
4. Printed circuit assembly (pca) part number and revision letter as printed in ink on the board.
5. The reference designation or item number of the part
6. Quantity

Price information for parts is available from the John Fluke Mfg. Co., Inc., and its authorized representatives. Prices are also available in a Fluke Replacement Parts Catalog, which is available on request.

## CAUTION

An asterisk (\*) indicates a device that may be damaged by static discharge.

## TECHNICAL SERVICE CENTERS

4-3.

A list of technical service centers is included at the end of this section.



Table 4-1. Final Assembly (Models 77, 75, 23, 21)  
(See Figure 4-1.)

REFERENCE DESIGNATOR	FLUKE STOCK	MFRS SPLY	MANUFACTURERS PART NUMBER	TOT QTY	N O T E
-A>-NUMERICS-->	S-----	DESCRIPTION-----	--NO-- -CODE--	-OR GENERIC TYPE-----	-E-
A 1		* MAIN PCA	NON-PROCURABLE	1	
BT 1		BATTERY, 9V, 0-15MA	696534 59717 216	1	
F 1		FUSE, 5X20MM, 0.63A, 250V, FAST	740670 71400 GDA-630MA	1	
F 3		FUSE, .406X1.5, 15A, 600V, FAST	820829 71400 KTK-15	1	
H 1		SCREW, THD FORM, PH, P, STL, 4-24, .250	519116 COMMERCIAL	1	
H 2		SCREW, THD FORM, PH, P, 2-14, .375	821140 COMMERCIAL	1	
H 3		SCREW, THD FORM, PH, P, STL, 4-14, .375	448456 COMMERCIAL	4	
H 7		SCREW, THD FORM, PH, P, STL, 5-14, .750	733410 COMMERCIAL	4	
LS 1		AF TRANSD, PIEZO, 20 MM	642991 51406 7BB-20-604	1	
MP 9		SHIELD, TOP	819300 89536 819300	1	
MP 10- 13		FOOT, NON-SKID	640565 2K262 640565	4	
MP 14		CASE, BOTTOM	896316 89536 896316	1	1
MP 15		SHIELD, BOTTOM	896225 89536 896225	1	
MP 16		SPRING, COIL, COMP, M WIRE, .500, .360	697227 27745 C0360-026-0500	1	
MP 17		CASE, TOP	896311 89536 896311	1	2
MP 18		WINDOW, LCD	885850 89536 885850	1	3
MP 19		BRACKET, LCD	646653 89536 646653	1	
MP 20		MASK, BRACKET	885848 89536 885848	1	
MP 21, 22		CONN, ELASTOMERIC, LCD TO PWB, 1.900 L	649632 0K392 SG	2	
MP 23		SWITCH, KNOB	885843 89536 885843	1	4
MP 24		SHAFT, KNOB	646661 89536 646661	1	
MP 25		SPRING, DETENT	646679 89536 646679	1	
MP 26		SHOCK ABSORBER	428441 25099 428441	1	
MP 27		DECAL, CASE TOP	896332 89536 896332	1	5
MP 28		LABEL, WINDOW FLUKE-PHILIPS	844340 89536 844340	1	
MP 31		HOLSTER & FLEXSTAND ASSY	890298 89536 890298	1	6
MP 32		TEST LEADS	855742 89536 855742	1	
MP 33		MANUAL, PAMPHLET, DMM ACCESSORY LIST	825851 89536 825851	1	
S 2		SWITCH, MOMENTARY	890280 89536 890280	1	7
S 4		CONTACT, ANNUNCIATOR	642983 89536 642983	1	
TM 1		OPERATOR MANUAL	896191 89536 896191	1	
TM 2		SERVICE MANUAL	896204 89536 896204	1	
U 3		LCD, 3.75 DIGIT, BAR GRAPH, MULTIPLIED	640581 62786 LS-068-C	1	

An \* in 'S' column indicates a static-sensitive part.

NOTES:

- NOTE 1 = For Fluke Model 21,23 Stock No. is 895792.
- NOTE 2 = For Fluke Model 21,23 Stock No. is 745661.
- NOTE 3 = For Fluke Model 21 Stock No. is 895797.  
For Fluke Model 23 Stock No. is 895826.  
For Fluke Model 75 Stock No. is 896324.
- NOTE 4 = For Fluke Model 21,23 Stock No. is 748129.
- NOTE 5 = For Fluke Model 21,23 Stock No. is 895813.
- NOTE 6 = Not used on Fluke Model 21.
- NOTE 7 = For Fluke Model 21,23 Stock No. is 895800.

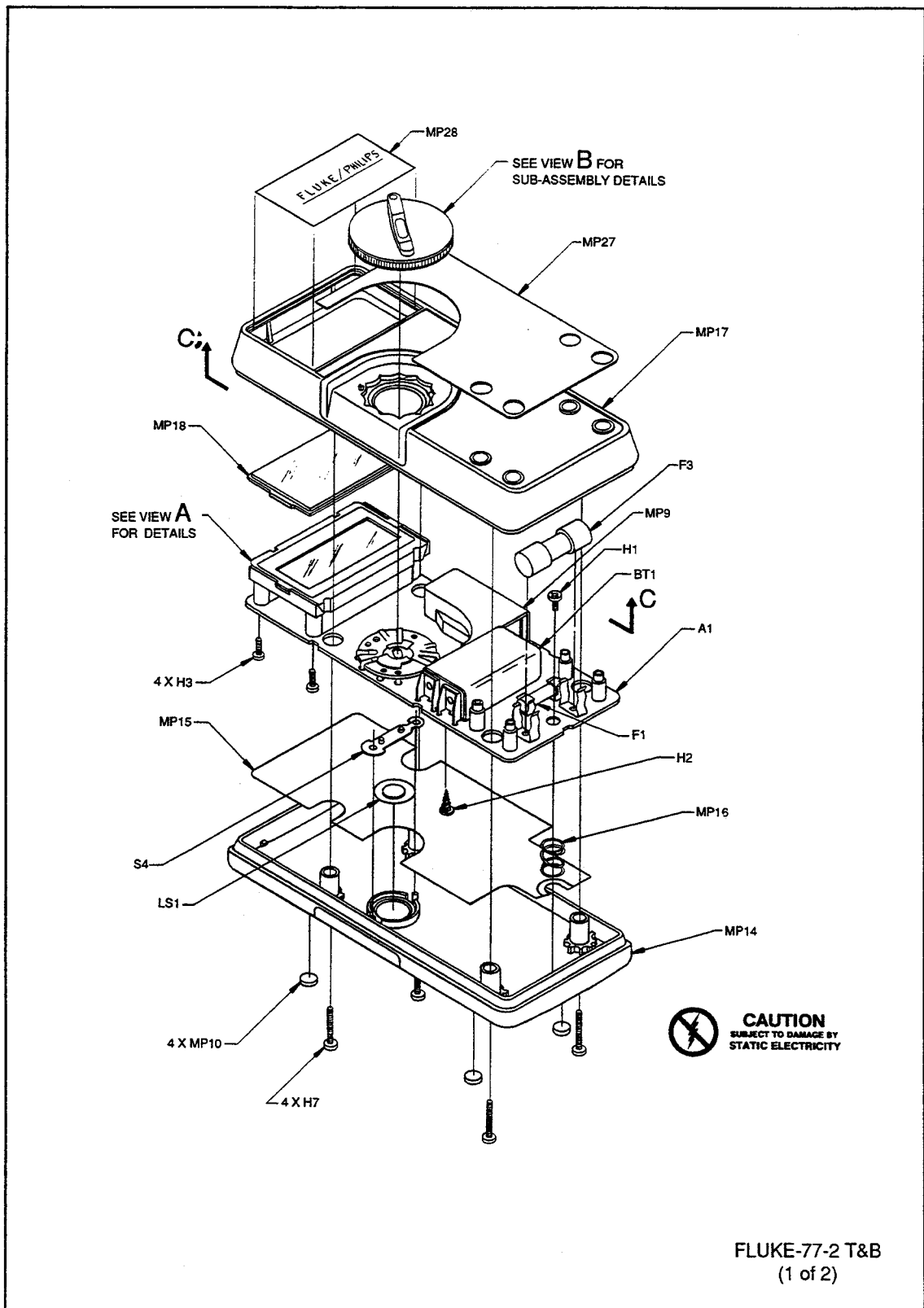
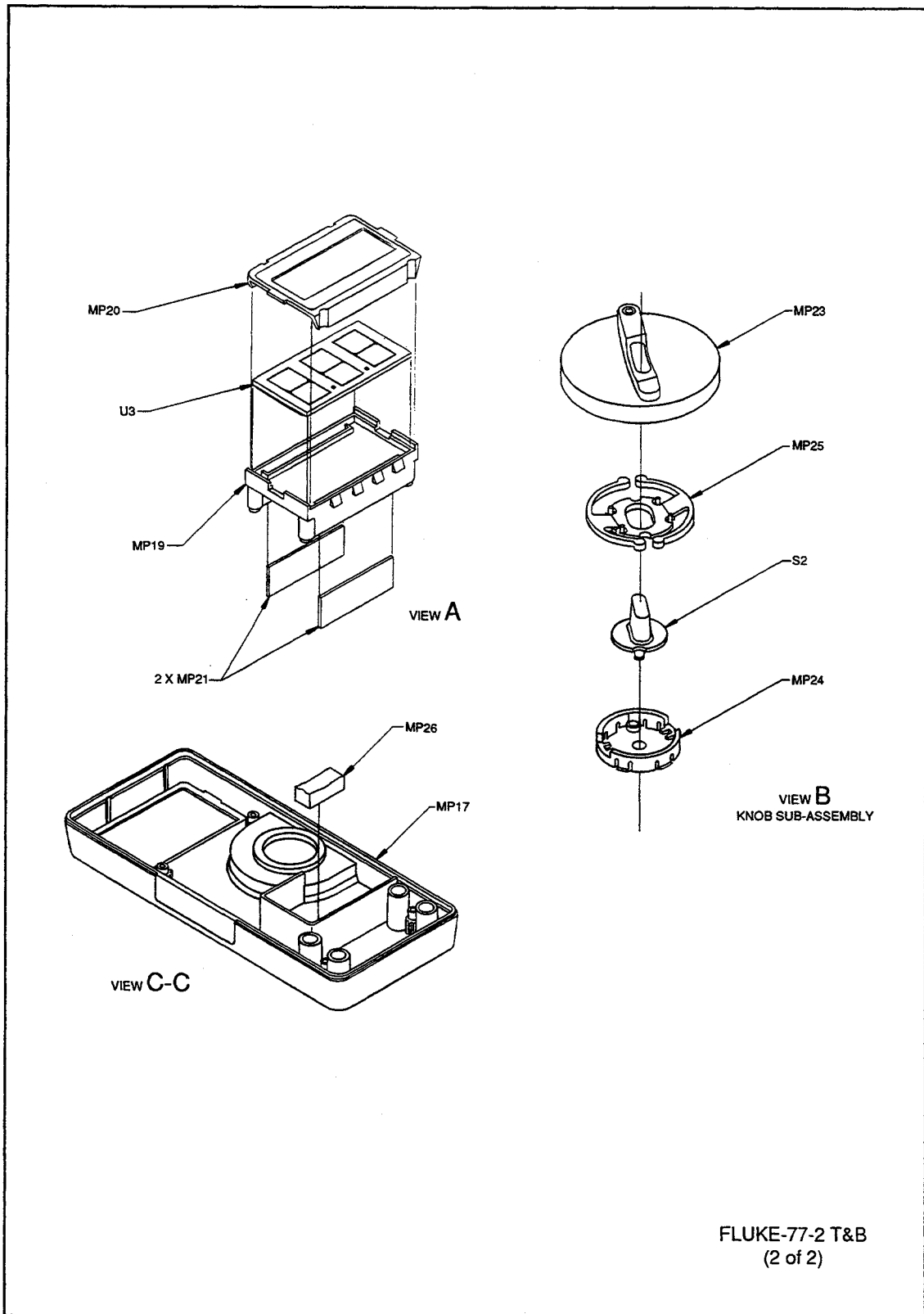

Figure 4-1. Final Assembly (Models 77, 75, 23, 21)



FLUKE-77-2 T&B  
(2 of 2)

Figure 4-1. Final Assembly (Models 77, 75, 23, 21) (cont)

# List of Replaceable Parts

Table 4-2. A1 Main PCA (Models 77,75,23,21)  
(See Figure 4-2.)

REFERENCE DESIGNATOR	FLUKE STOCK	MFRS SPLY	MANUFACTURERS PART NUMBER	TOT QTY	N O T
-A>-NUMERICS-----> S-----DESCRIPTION-----	--NO--	-CODE-	-OR GENERIC TYPE-----	QTY-	-E-
C 1	721019	60935	MKT-1.60	1	
C 2, 10	655035	56289	199D474X0035AG2	2	
C 4	650069	62643	SRAC50VB2R2M4X7C3	1	
C 5, 6	720979	68919	MKC2-272-K-63V	2	
C 7	697409	60935	185-2/0.47/K/0050/R/A/B	1	
C 8	721050	68919	MKP20-333-K-63V	1	
C 9	655043	56289	199D685X0010BG2	1	
C 11	706804	56289	199D225X0016AE2	1	
C 12	706705	04222	SR595A470MAATR1A	1	
C 13	733386	04222	SR595E224ZAATR1A	1	
C 14, 15	714543	04222	SR595A330JAATR1A	2	
CR 1, 2	659516	03508	1N4448	2	
DS 1	655134	91984	100T1	1	
J 1- 4	642959	89536	642959	4	
MP 2, 3	697086	61857	H-0011-2	2	
MP 4, 5	707190	76970	707190	2	
MP 6	642967	89536	642967	1	
MP 7	654228	89536	654228	1	
Q 1, 3	685404	04713	SPS8763RLRA	2	
Q 2	698225	04713	2N3904RLRA	1	
R 1	650085	91637	CMF65 1001 F T-1	1	
R 2, 3	655175	19647	MS214-105-5%-200PPM/C	2	
R 4	658963	59124	CF1-4 VT 104 J B	1	
R 5	706739	59124	MF55D4023C	1	
R 6	655019	91637	NS-2C4R99F	1	
R 7	740415	91637	SPR R005F	1	
R 8	649897	51406	RVG-0707-V-100-3-104M	1	
R 9, 19	649970	59124	CF1-4 VT 105 J B	2	
R 10	649962	59124	CF1-4 VT 155 J B	1	
R 11	655217	59124	MF50DVT3323F REEL	1	
R 12	655274	59124	MF50DVT3013F REEL	1	
R 13	706747	59124	MF50DVT4482C REEL	1	
R 14	713941	59124	CF1-4 VT 623 J B	1	
R 15	706242	59124	MF50DVT5622F REEL	1	
R 16	706234	59124	MF50DVT2053F REEL	1	
R 17	682716	59124	MF50DVT2052D REEL	1	
R 18	715219	59124	MF50DVT9201D REEL	1	
R 20	740662	23237	SFF360K	1	
RT 1	446849	54583	911P84E102YU13	1	
RV 1, 2	876193	09214	V910LSX1399	2	
S 1	642918	89536	642918	1	
U 1	683052	89536	683052	1	
U 2	659656	18520	LR3676	1	
VR 1	634451	12040	LM385Z-1.2D26Z	1	
W 2	682575	91637	FRJ-55	1	
W 5	747394	60386	747394	1	
Y 1	643031	5W664	NDK-32.768	1	
Z 1	683797	89536	683797	1	

An \* in 'S' column indicates a static-sensitive part.

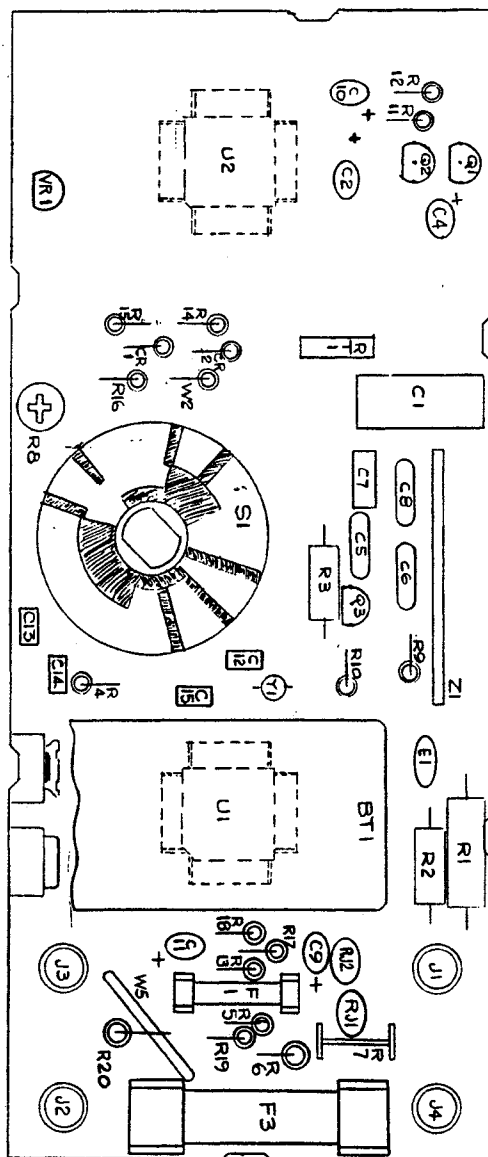

FLUKE-77-1621

Figure 4-2. A1 Main PCA (Models 77, 75, 23, 21) (cont)

# List of Replaceable Parts

Table 4-3. Final Assembly (Model 73)  
(See Figure 4-3.)

REFERENCE DESIGNATOR	FLUKE STOCK	MFRS SPLY	MANUFACTURERS PART NUMBER	TOT QTY	N O T E
-A>-NUMERICS--> S-----DESCRIPTION-----	--NO--	-CODE-	-OR GENERIC TYPE----	-E-	
A 1			NON-PROCURABLE	1	
BT 1	696534	59717	216	1	
F 3	820829	71400	KTk-15	1	
H 1	519116		COMMERCIAL	1	
H 2	821140		COMMERCIAL	1	
H 3	448456		COMMERCIAL	4	
H 7	733410		COMMERCIAL	4	
LS 1	642991	51406	7BB-20-604	1	
MP 9	819300	89536	819300	1	
MP 10- 13	640565	2K262	640565	4	
MP 14	896340	89536	896340	1	
MP 15	896225	89536	896225	1	
MP 16	697227	27745	C0360-026-0500	1	
MP 17	896337	89536	896337	1	
MP 18	896345	89536	896345	1	
MP 19	646653	89536	646653	1	
MP 20	885848	89536	885848	1	
MP 21, 22	649632	OK392	SG	2	
MP 23	885843	89536	885843	1	
MP 24	646661	89536	646661	1	
MP 25	646679	89536	646679	1	
MP 26	428441	25099	428441	1	
MP 27	896357	89536	896357	1	
MP 28	844340	89536	844340	1	
MP 32	855742	89536	855742	1	
MP 33	825851	89536	825851	1	
S 2	890280	89536	890280	1	
S 4	642983	89536	642983	1	
TM 1	896191	89536	896191	1	
TM 2	896204	89536	896204	1	
U 3	640581	62786	LS-068-C	1	

An \* in 'S' column indicates a static-sensitive part.

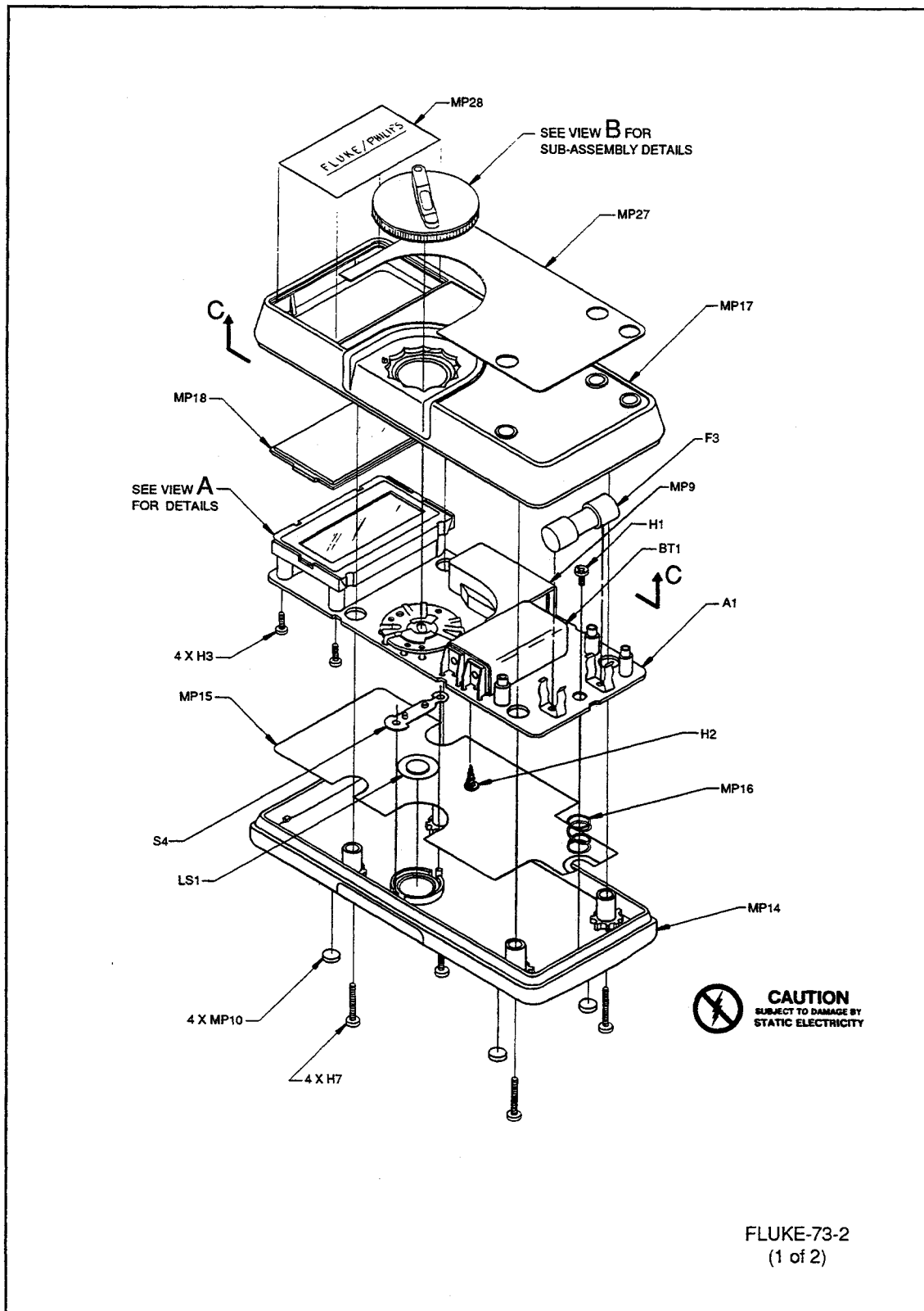
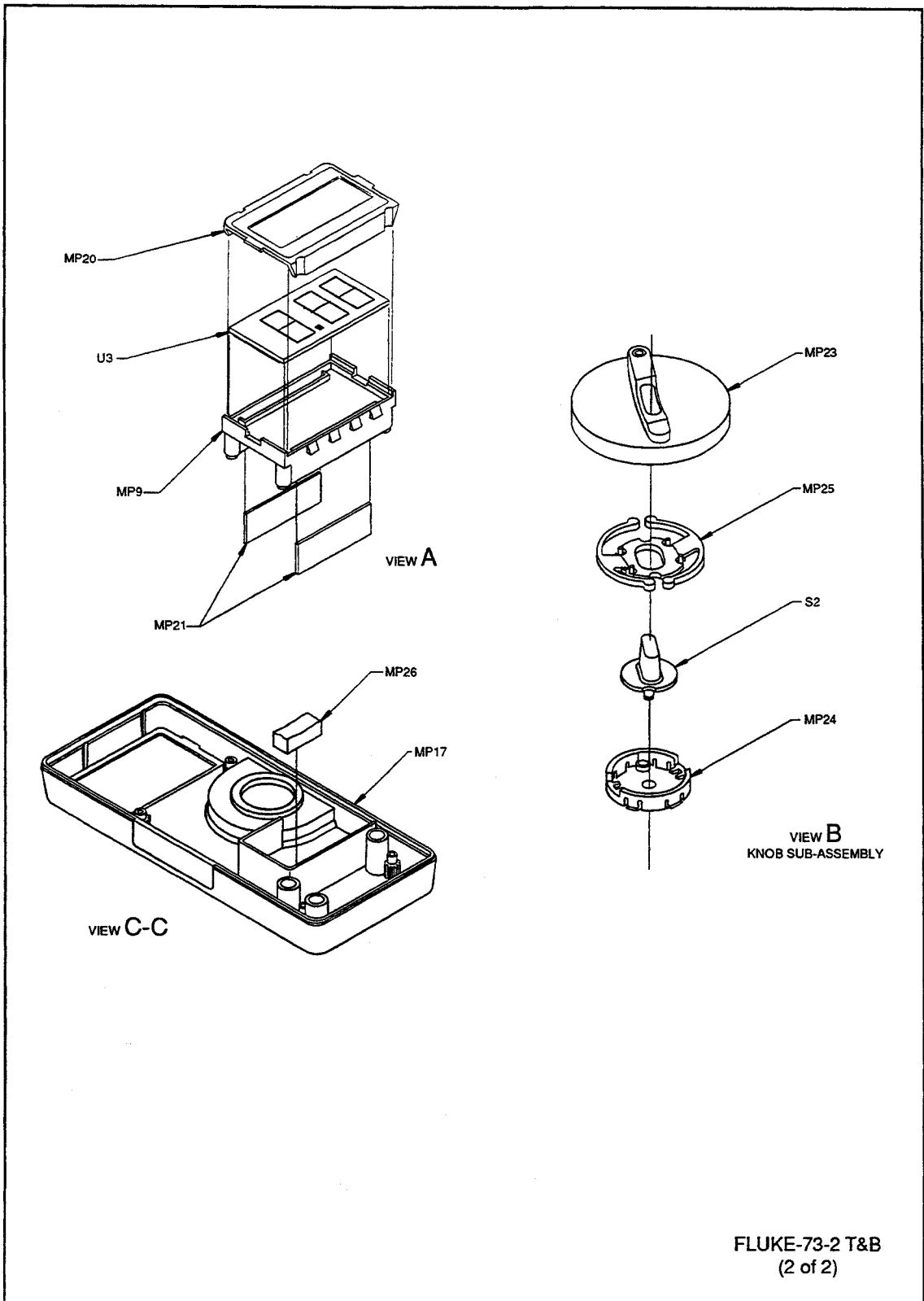

Figure 4-3. Final Assembly (Model 73)



FLUKE-73-2 T&B  
(2 of 2)

Figure 4-3. Final Assembly (Model 73) (cont)



Table 4-4. A1 Main PCA (Model 73)  
(See Figure 4-4.)

REFERENCE DESIGNATOR	FLUKE STOCK	MFRS SPLY	MANUFACTURERS PART NUMBER	TOT QTY	N O T T E
-A>-NUMERICS-----> S-----DESCRIPTION-----	--NO--	-CODE-	-OR GENERIC TYPE-----	QTY-	-E-
C 1	721019	60935	MKT-1.60	1	
C 2, 10	655035	56289	199D474X0035AG2	2	
C 4	650069	62643	SRAC50VB2R2M4X7C3	1	
C 5, 6	720979	68919	MKC2-272-K-63V	2	
C 7	697409	60935	185-2/0.47/K/0050/R/A/B	1	
C 8	721050	68919	MKP20-333-K-63V	1	
C 9	655043	56289	199D685X0010BG2	1	
C 11	706804	56289	199D225X0016AE2	1	
C 12	706705	04222	SR595A470MAATRIA	1	
C 13	733386	04222	SR595E224ZAATRIA	1	
C 14, 15	714543	04222	SR595A330JAATRIA	2	
CR 1, 2	659516	03508	1N4448	2	
DS 1	655134	91984	100T1	1	
J 1, 3, 4	642959	89536	642959	3	
MP 4, 5	707190	76970	707190	2	
MP 6	642967	89536	642967	1	
MP 7	654228	89536	654228	1	
Q 1, 3	685404	04713	SP58763RLRA	2	
Q 2	698225	04713	2N3904RLRA	1	
R 1	650085	91637	CMF65 1001 F T-1	1	
R 2, 3	655175	19647	MS214-105-5%-200PPM/C	2	
R 4	658963	59124	CF1-4 VT 104 J B	1	
R 5	706754	59124	CF1-4 VT 394 J B	1	
R 7	740415	91637	SPR R005F	1	
R 8	649897	51406	RVG-0707-V-100-3-104M	1	
R 9, 19	649970	59124	CF1-4 VT 105 J B	2	
R 10	649962	59124	CF1-4 VT 155 J B	1	
R 11	655217	59124	MF50DVT3323F REEL	1	
R 12	655274	59124	MF50DVT3013F REEL	1	
R 14	713941	59124	CF1-4 VT 623 J B	1	
R 15	706242	59124	MF50DVT5622F REEL	1	
R 16	706234	59124	MF50DVT2053F REEL	1	
R 17	682716	59124	MF50DVT2052D REEL	1	
R 18	715219	59124	MF50DVT9201D REEL	1	
RT 1	446849	54583	911P84E102YU13	1	
RV 1, 2	876193	09214	V910LSX1399	2	
S 1	642918	89536	642918	1	
U 1	683052	89536	683052	1	
U 2	659656	18520	LR3676	1	
VR 1	634451	12040	LM3852-1.2D262	1	
W 2- 4	682575	91637	FRJ-55	3	
W 5	747394	60386	747394	1	
Y 1	643031	5W664	NDK-32.768	1	
Z 1	683797	89536	683797	1	

An \* in 'S' column indicates a static-sensitive part.

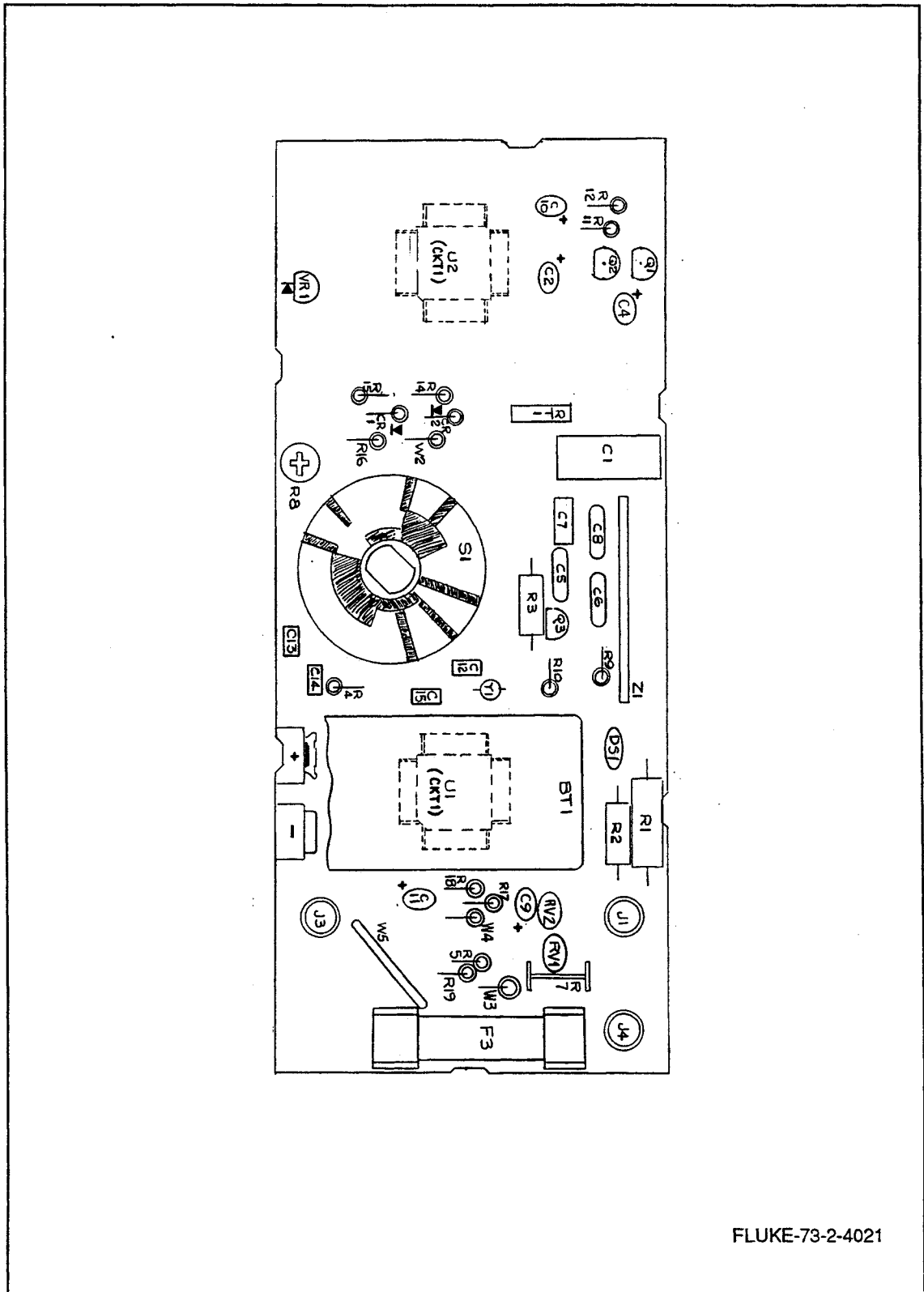

FLUKE-73-2-4021

Figure 4-4. A1 Main PCA (Model 73)

Table 4-5. Final Assembly (Model 70)  
(See Figure 4-5.)

REFERENCE DESIGNATOR		FLUKE STOCK	MFRS SPLY	MANUFACTURERS PART NUMBER		N O T
-A> NUMERICS-->	S-----DESCRIPTION-----	--NO--	--CODE--	-OR GENERIC TYPE----	QTY-	-E-
A	1			NON-PROCURABLE		1
BT	1			BATTERY, 9V, 0-15MA		1
H	1	696534	59717	216		1
H	2	519116		COMMERCIAL		1
H	3	821140		COMMERCIAL		1
H	7	448456		COMMERCIAL		4
LS	1	733410		COMMERCIAL		4
MP	9	642991	51406	7BB-20-604		1
MP	10- 13	819300	89536	819300		1
MP	14	640565	2K262	640565		4
MP	15	896365	89536	896365		1
MP	16	896225	89536	896225		1
MP	17	697227	27745	C0360-026-0500		1
MP	18	896360	89536	896360		1
MP	19	896373	89536	896373		1
MP	20	646653	89536	646653		1
MP	21, 22	885848	89536	885848		1
MP	23	649632	0K392	SG		2
MP	24	885843	89536	885843		1
MP	25	646661	89536	646661		1
MP	26	646679	89536	646679		1
MP	27	428441	25099	428441		1
MP	28	895784	89536	895784		1
MP	32	844340	89536	844340		1
MP	33	855742	89536	855742		1
S	2	825851	89536	825851		1
S	4	890280	89536	890280		1
TM	1	642983	89536	642983		1
TM	2	896191	89536	896191		1
U	3	896204	89536	896204		1
		640581	62786	LS-068-C		1

An \* in 'S' column indicates a static-sensitive part.

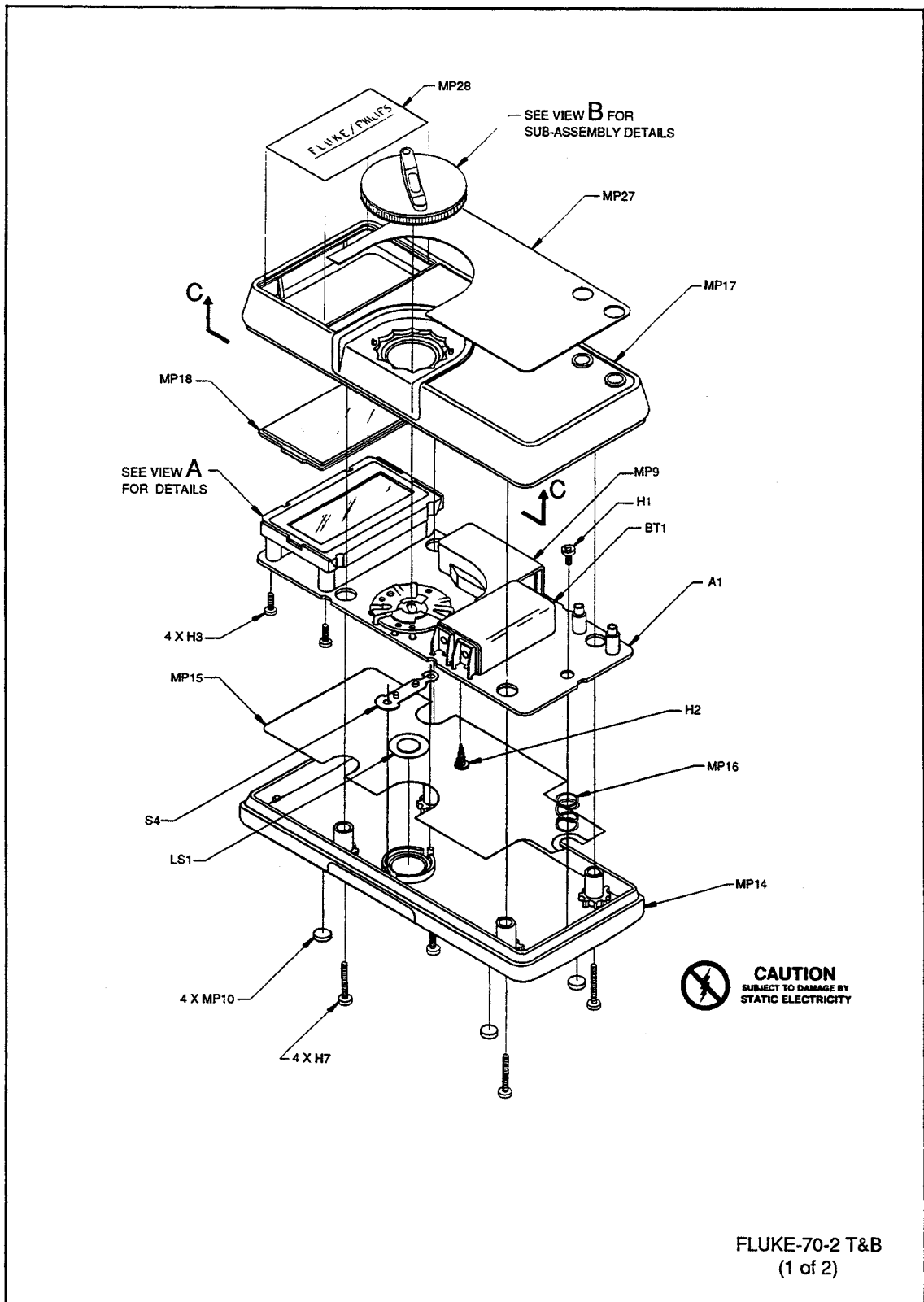

Figure 4-5. Final Assembly (Model 70)

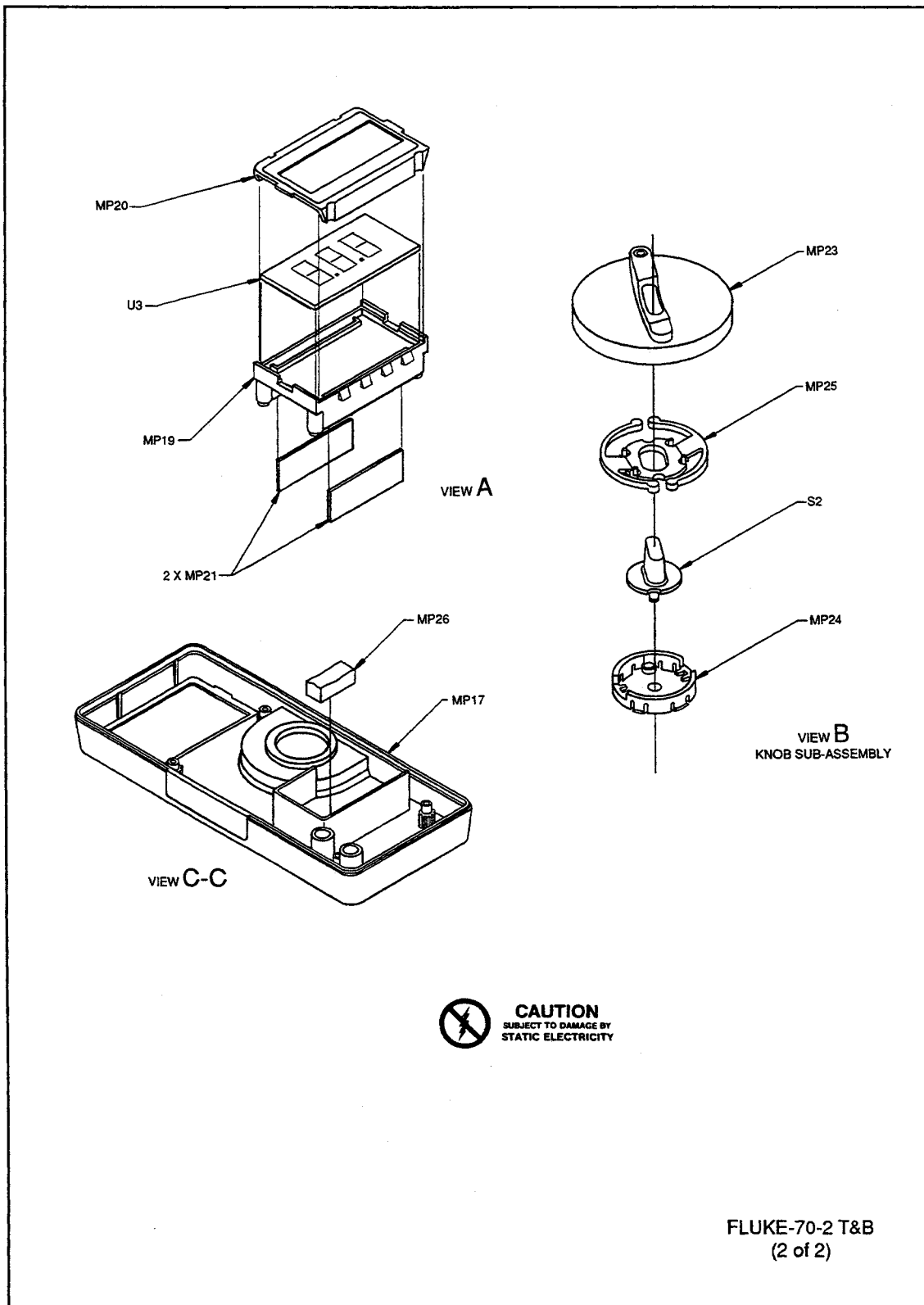

Figure 4-5. Final Assembly (Model 70) (Cont)

# List of Replaceable Parts

Table 4-6. AI Main PCA (Model 70)  
(See Figure 4-6.)

REFERENCE DESIGNATOR	FLUKE STOCK	MFRS SPLY	MANUFACTURERS PART NUMBER	TOT	N
-A>-NUMERICS--> S-----DESCRIPTION-----	--NO--	-CODE-	-OR GENERIC TYPE----	QTY-	-E-
C 1	721019	60935	MKT-1.60	1	
C 2, 10	655035	56289	199D474X0035AG2	2	
C 4	650069	62643	SRAC50VB2R2M4X7C3	1	
C 5, 6	720979	68919	MKC2-272-K-63V	2	
C 7	697409	60935	185-2/0.47/R/0050/R/A/B	1	
C 8	721050	68919	MKP20-333-K-63V	1	
C 9	655043	56289	199D685X0010BG2	1	
C 11	706804	56289	199D225X0016AE2	1	
C 12	706705	04222	SR595A470MAATRIA	1	
C 13	733386	04222	SR595E224ZAATRIA	1	
C 14, 15	714543	04222	SR595A330JAATRIA	2	
CR 1, 2	659516	03508	1N4448	2	
DS 1	655134	91984	100T1	1	
J 1, 4	642959	89536	642959	2	
MP 6	642967	89536	642967	1	
MP 7	654228	89536	654228	1	
Q 1, 3	685404	04713	SPS8763RLRA	2	
Q 2	698225	04713	2N3904RLRA	1	
R 1	650085	91637	CMF65 1001 F T-1	1	
R 2, 3	655175	19647	MS214-105-5*-200PPM/C	2	
R 4	658963	59124	CF1-4 VT 104 J B	1	
R 8	649897	51406	RVG-0707-V-100-3-104M	1	
R 9, 19	649970	59124	CF1-4 VT 105 J B	2	
R 10	649962	59124	CF1-4 VT 155 J B	1	
R 11	655217	59124	MF50DVT3323F REEL	1	
R 12	655274	59124	MF50DVT3013F REEL	1	
R 14	713941	59124	CF1-4 VT 623 J B	1	
R 15	706242	59124	MF50DVT5622F REEL	1	
R 16	706234	59124	MF50DVT2053F REEL	1	
R 17	682716	59124	MF50DVT2052D REEL	1	
R 18	715219	59124	MF50DVT9201D REEL	1	
RT 1	446849	54583	911P84E102YU13	1	
RV 1, 2	876193	09214	V910LSX1399	2	
S 1	642918	89536	642918	1	
U 1	683052	89536	683052	1	
U 2	659656	18520	LR3676	1	
VR 1	634451	12040	LM3852-1.2D26Z	1	
W 2, 4	682575	91637	FRJ-55	2	
Y 1	643031	5W664	NDK-32.768	1	
Z 1	616870	89536	616870	1	

An \* in 'S' column indicates a static-sensitive part.

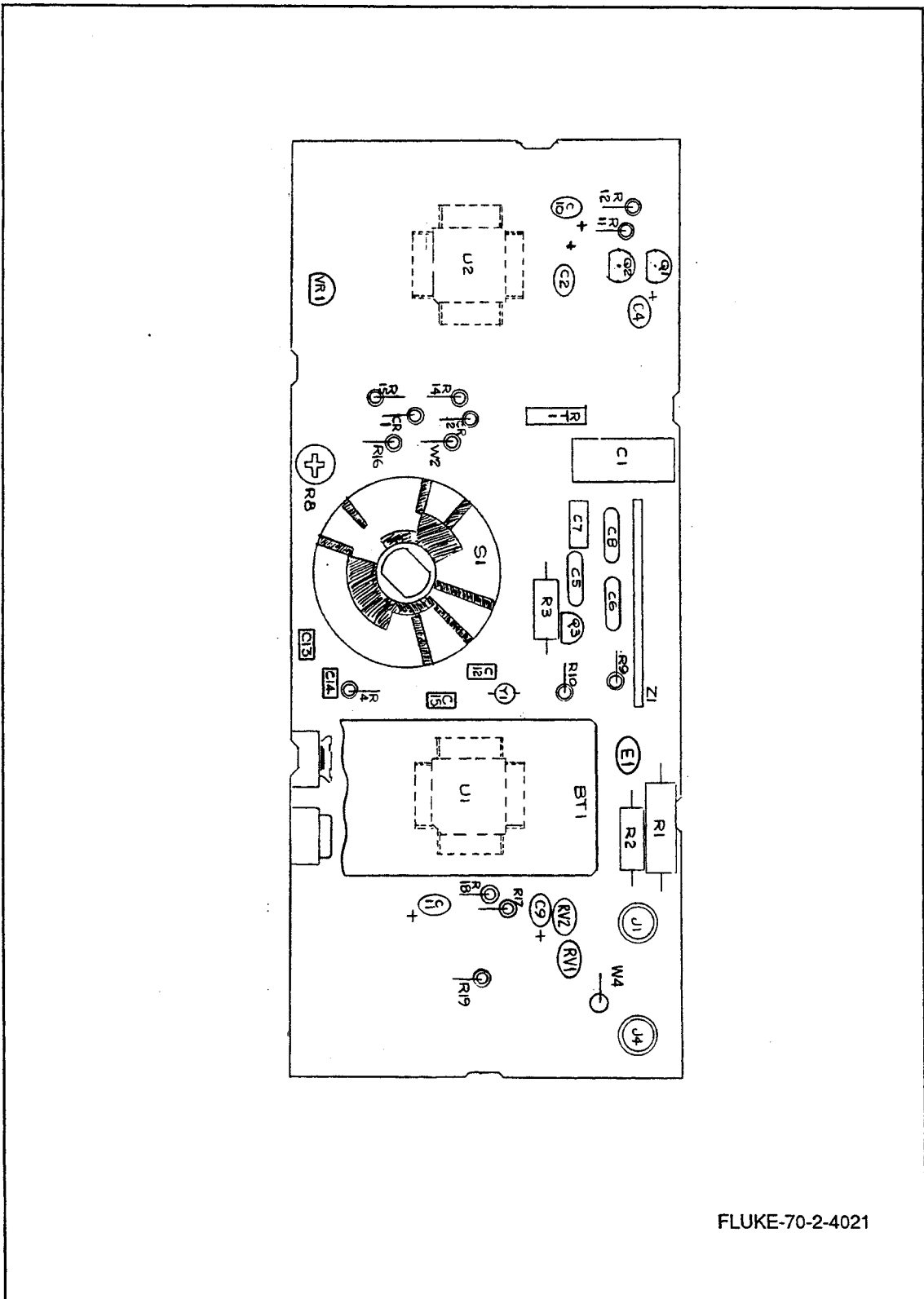

FLUKE-70-2-4021

Figure 4-6. A1 Main PCA (Model 70)

**List of Replaceable Parts**  
 Manufacturer's Federal Supply Codes

**MANUFACTURER'S FEDERAL SUPPLY CODES**

03508 General Electric Co. Semiconductor Products Dept. Auburn, NY	19647 Caddock Electronics Inc. Riverside, CA	59124 KOA-Speer Electronics Inc. Bradford, PA	68919 Inter-Technical Group Inc., The Irvington, NY
04222 AVX Corp. AVX Ceramics Div. Myrtle Beach, SC	23237 I R C, Inc. Microcircuits Div Philadelphia, PA	59717 Eveready Battery Co. Inc. St. Louis, MO	71400 Bussman Div. of Cooper Industries Inc. St. Louis, MO
04713 Motorola Inc. Semiconductor Products Sector Phoenix, AZ	25099 Cascade Gasket & Mfg. Co. Inc. Kent, WA	5W664 NDK America Inc. Div. of Nihon Dempa Kogyo LTD Lynchburg, VA	7G970 Connor Spring & Mfg. Co. San Jose, CA
09214 General Electric Co. Semiconductor Products Dept. Auburn, NY	27745 Associated Spring Barnes Group Inc. Syracuse, NY	60386 Squires Electronics Inc. Cornelius, OR	89536 John Fluke Mfg. Co., Inc. Everett, WA
0K392 Skin-Etsu Silicones of America Torrance, CA	2K262 Boyd Corp. Portland, OR	60935 Westlake Capacitor Inc. Tantalum Div. Greencastle, IN	91637 Dale Electronics Inc. Columbus, NE
12040 National Semiconductor Corp. Danbury, CT	51406 Murata Erie, No. America Inc. Symma, GA	61857 SAN-O Industrial Corp. Bohemia, NY	91984 Maida Development Co. Hampton, VA
18520 Sharp Electronics Corp. Professional Products Div. Mahwah, NJ	54583 TDK Electronics Corp. Port Washington, NY	62643 United Chemi-con Inc. Rosemont, IL	
	56289 Sprague Electric Co. Nashua, NH	62786 Hitachi America Ltd. Semiconductor & IC Div. San Jose, CA	



# Section 5 Schematic Diagrams

## TABLE OF CONTENTS

FIGURE	TITLE	PAGE
5-1	A1 Main PCA .....	5-3
5-2	Signal Flow Diagram .....	5-5

Table 5-1. Abbreviations

ABBREVIATION	DEFINITION
ACA	AC Converter Feedback
ACHI	AC Converter High
ACL	All Clear, Reset
ACLO	AC Converter Low
AFI	Active Filter Input
AFO	Active Filter Output
AMQ	Amps Input
AM1	Amps Divide by 10
AZ	Auto Zero Point
BPR	Beeper Driver
BT	Battery
CLK	Clock Output
COM	Common
DCS	DC Sense
EC	Reference Voltage
FA0	Active Filter Amp Output
FA(-)	Active Filter Amp Feedback
INT	Integrator Output
K0	Buffer x 1 Output
K1	Buffer Divide by 3 Output
LS	Loud Speaker
LO	Low
OHS	Ohms Sense
RNG	Range
RRS	Reference Resistor Sense
RT	Thermistor
VSS	Negative Supply Voltage
VDD	Positive Supply Voltage
VM	Volts Middle
WW	Wirewound
XTL	Crystal Oscillator Inputs
Z	Impedance

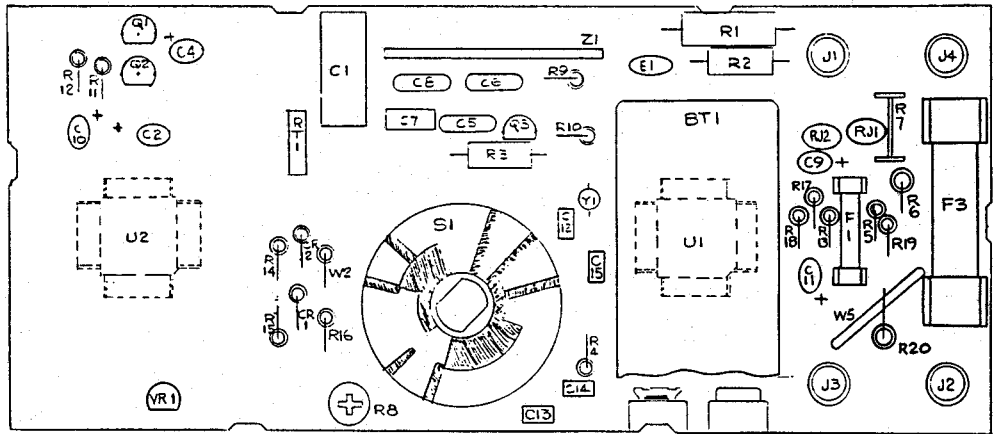

MODELS 77, 75, 23, 21  
(FLUKE 77-2-4021)

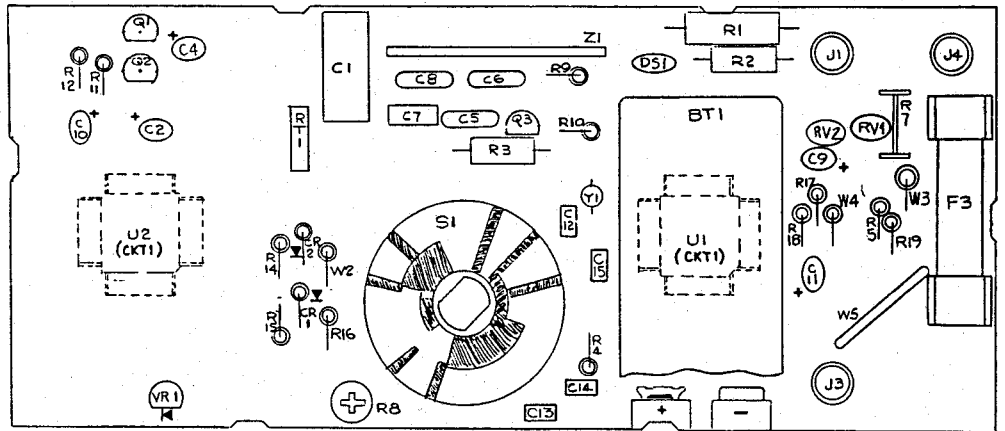

MODEL 73  
(FLUKE 73-2-4021)

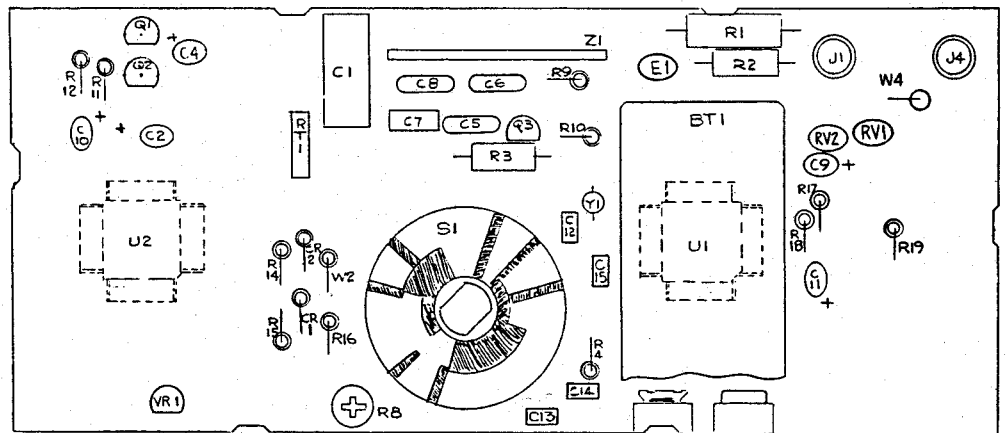

MODEL 70  
(FLUKE 70-2-4021)

REFERENCE DESIGNATION		HIGHEST	NOT USED
U	R	3	21
N	Q	20	23
C	R	15	
T	R	1	
C	R	2	
V	Y	3	
S	Y	1	
M	Y	2	
R	M	1,3,4	

WARNING: R1 IS A FUSIBLE RESISTOR. TO ENSURE SAFETY, USE EXACT REPLACEMENT ONLY.

MODEL(S) WHERE USED		
F1	77/5/29/21	73
F2		70
F3		
F4		
F5		
F6		
F7		
F8		
F9		
F10		
F11		
F12		
F13		
F14		
F15		
F16		
F17		
F18		
F19		
F20		
F21		
F22		
F23		
F24		
F25		
F26		
F27		
F28		
F29		
F30		
F31		
F32		
F33		
F34		
F35		
F36		
F37		
F38		
F39		
F40		
F41		
F42		
F43		
F44		
F45		
F46		
F47		
F48		
F49		
F50		
F51		
F52		
F53		
F54		
F55		
F56		
F57		
F58		
F59		
F60		
F61		
F62		
F63		
F64		
F65		
F66		
F67		
F68		
F69		
F70		
F71		
F72		
F73		
F74		
F75		
F76		
F77		
F78		
F79		
F80		
F81		
F82		
F83		
F84		
F85		
F86		
F87		
F88		
F89		
F90		
F91		
F92		
F93		
F94		
F95		
F96		
F97		
F98		
F99		
F100		

\* 390K

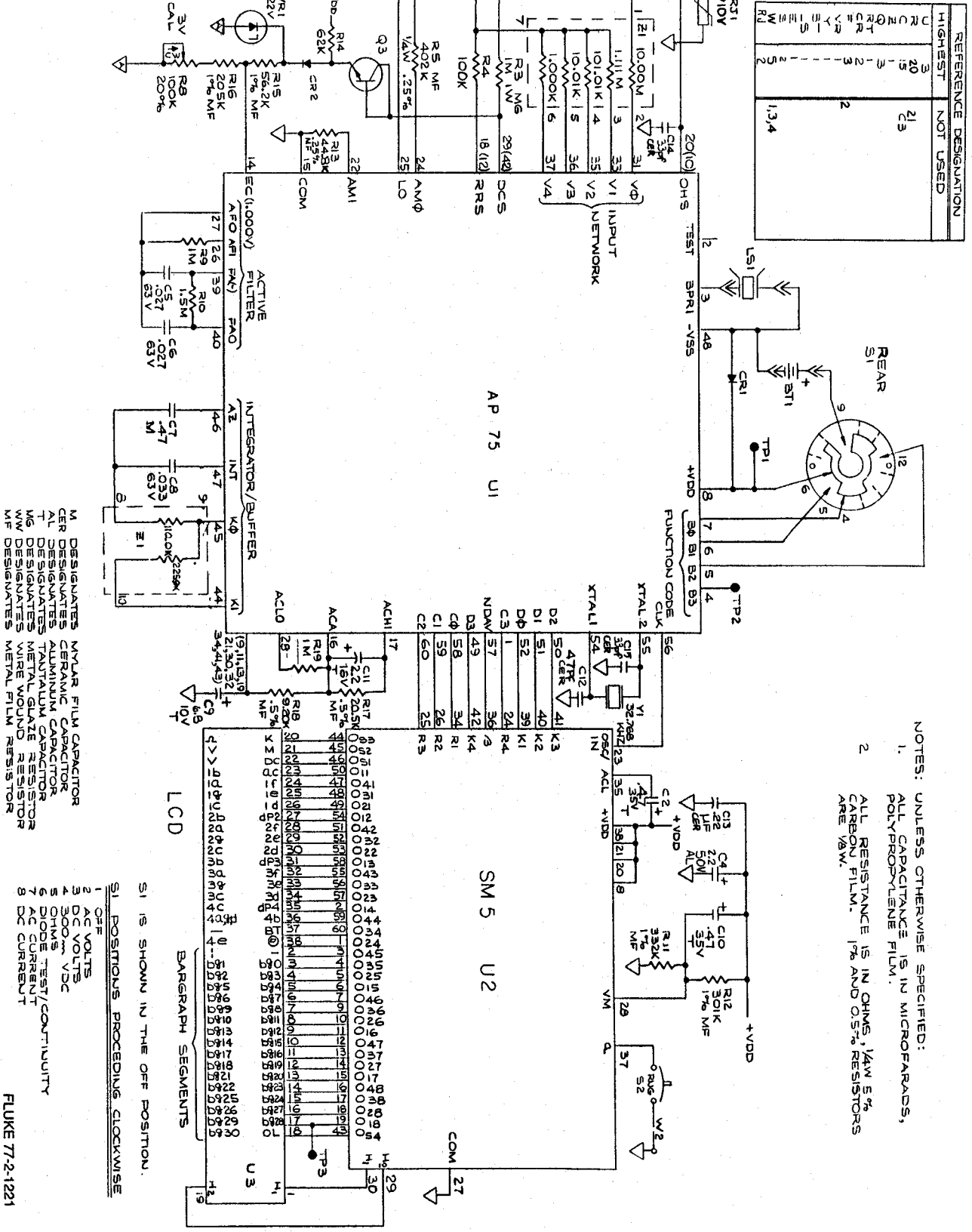

NOTES: UNLESS OTHERWISE SPECIFIED:  
 1. ALL CAPACITANCE IS IN MICROFARADS, POLYPROPYLENE FILM.  
 2. ALL RESISTANCE IS IN OHMS, 1/4W 5% CARBON FILM. 1% AND 0.5% RESISTORS ARE 1/8W.

FLUKE 77-2-1221

Figure 5-1. A1 Main PCA

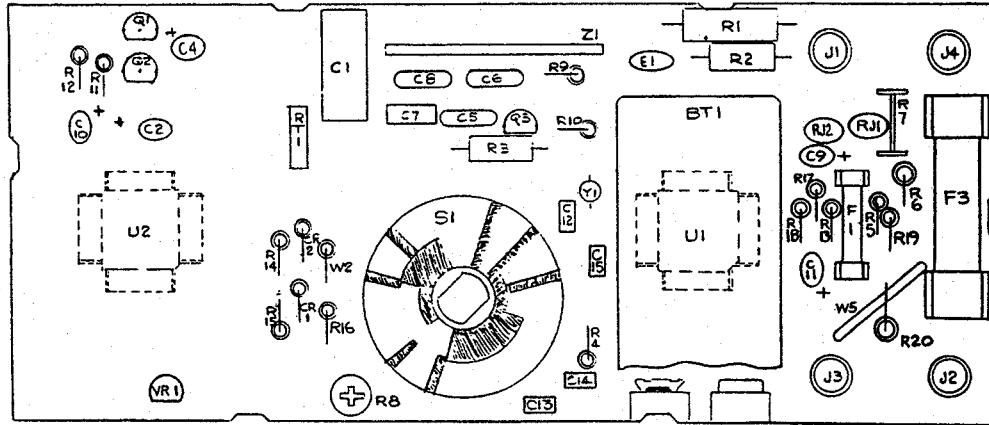

MODELS 77, 75, 23, 21  
(FLUKE 77-2-4021)

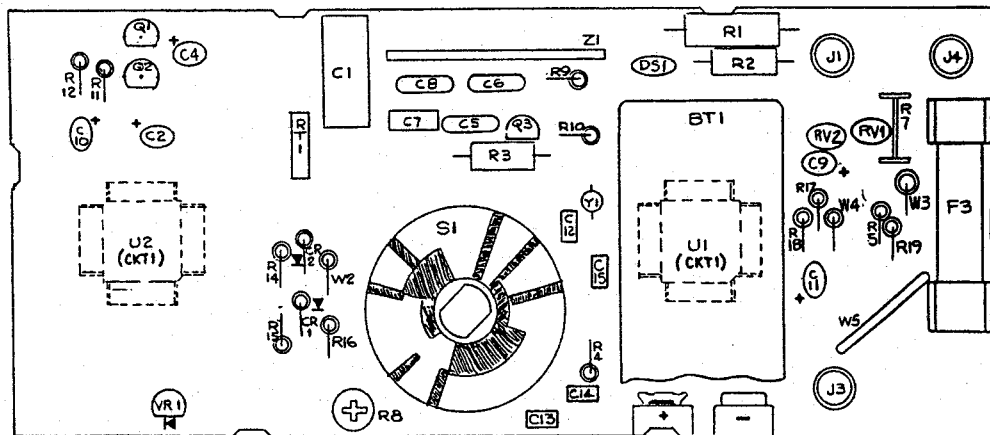

MODEL 73  
(FLUKE 73-2-4021)

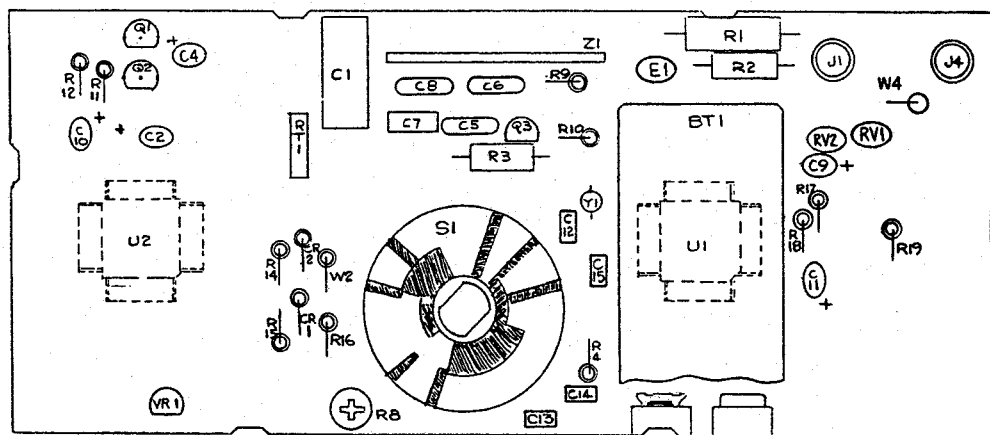

MODEL 70  
(FLUKE 70-2-4021)

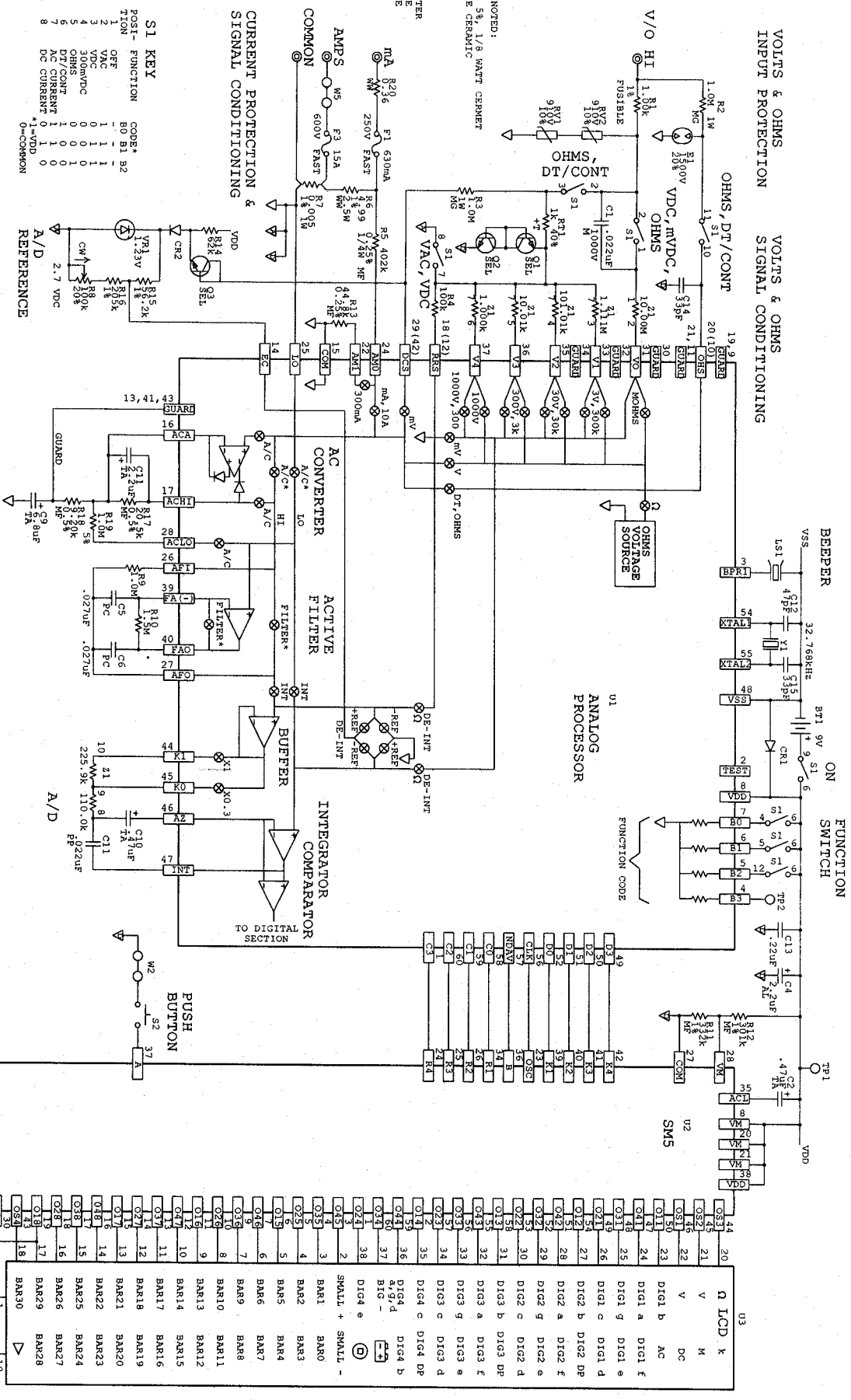

Figure 5-2. Signal Flow Diagram