

Enhancements for Ultra-high Resistance Measurements

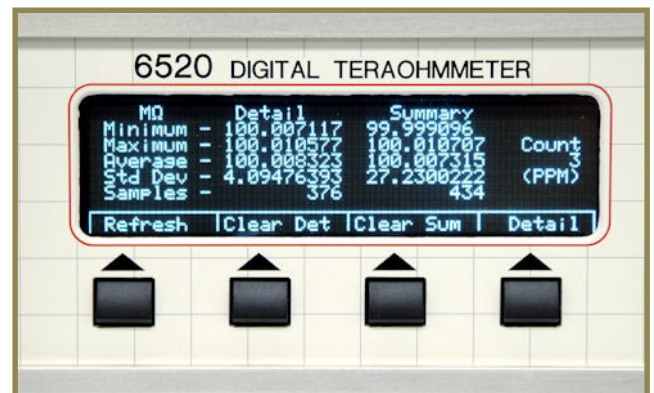

Guildline Instruments Limited 6520 Programmable Digital Teraohmmeter is Guildline's latest instrument standard capable of Resistive measurements to 10^{16} from Guildline Instruments. With wide range of available options, the Teraohmmeter can become truly a Metrologist tool, not just a measurement Instrument.

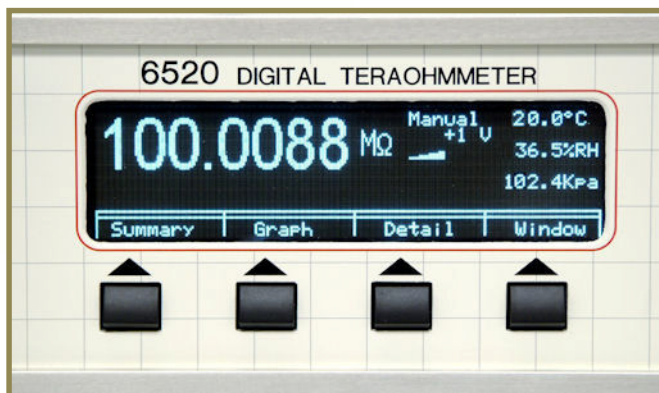
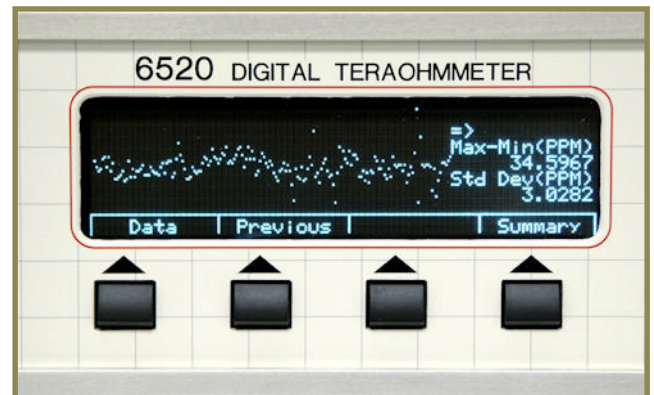

65201 PENN AIRBORNE (REFERENCE FIGURE 1)

The 65201 Penn Airborne enclosure is to allow the Penn Airborne series of High Value Resistors to be plugged directly in for ease of measurements by the 6520. The connectors are plugged into the front of the 6520. Since the Penn Airborne Resistors were susceptible to variables such as air flow and movement, this option is highly recommended if you calibrate these resistors.

Figure 1 - Penn Airborne Fixture

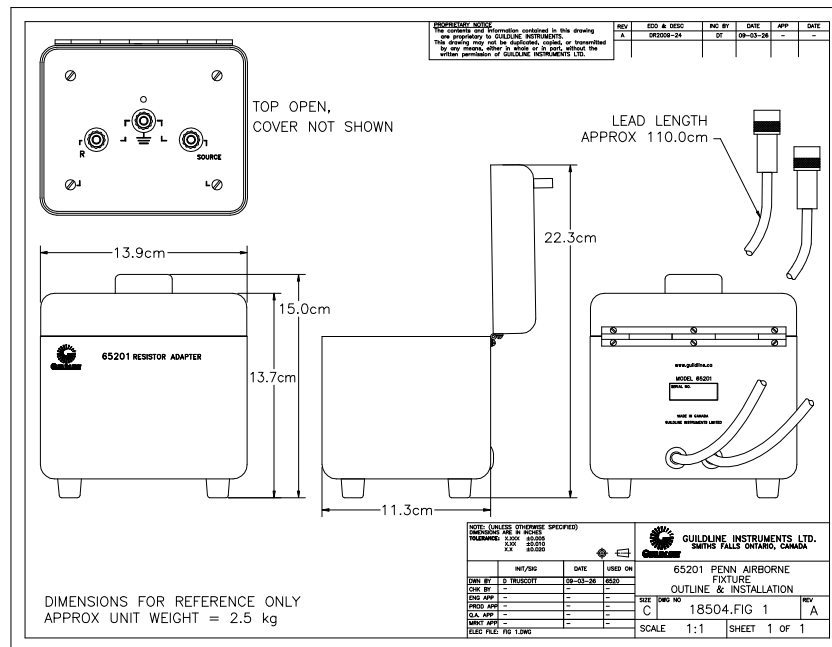

65220 ENVIRONMENTAL MONITOR

This option consists of two sensors that plug into the rear of the 6520. One sensor measures temperature and humidity, the second sensor measures barometric pressure. The sensors convert a volt input into a full scale reading. The temperature, humidity and pressure readings can be accessed via the front panel. The readings can also be time stamped.

Combined Temperature/Humidity Sensor (Reference Figure 2 and Figure 3)

Temperature/Humidity Sensor Construction

The RH Sensor construction consists of a planar capacitor with a second polymer layer to protect against dirt, dust, oils and other hazards.

The temperature sensors are precision integrated-circuit temperature sensors, whose output voltage is linearly proportional to the Celsius (Centigrade) temperature. The sensor thus has an advantage over linear temperature sensors calibrated in ° Kelvin, as the user is not required to subtract a large constant voltage from its output to obtain convenient Centigrade scaling.

Figure 2



The sensor does not require any external calibration or trimming to provide typical accuracies of $\pm .25^{\circ}\text{C}$ at room temperature and $\pm .75^{\circ}\text{C}$ over a full -55 to $+150^{\circ}\text{C}$ temperature range. The low output impedance, linear output, and precise inherent calibration make interfacing to readout or control circuitry especially easy. As it draws only $60\ \mu\text{A}$ from its supply, it has very low self-heating, less than 0.1°C in still air. The sensor is rated to operate over a -5°C to $+150^{\circ}\text{C}$ temperature range.

RH Sensor Specifications

Accuracy	$\pm 2\%$ RH, 0-100 % RH non-condensing, 25°C
Range RH	0 to 100% RH, non-condensing
Range Temperature	-40°C to 85°C (-40°F to 185°F)
Interchangeability	$\pm 5\%$ RH, 0-60% RH; $\pm 8\%$ @ 90% RH Typical
Hysteresis	$\pm 1.2\%$ of RH Span Maximum
Linearity	$\pm 0.5\%$ RH Typical
Repeatability	$\pm 0.5\%$ RH
Response Time	15 s in slowly moving air @ 25°C
Stability	$\pm 1\%$ RH Typical at 50% RH in 5 Years

Temperature Sensor Specifications

Stability (Room)	$\pm .25^{\circ}\text{C}$ at Range of 20 to 30°C
Stability Range	$\pm .55^{\circ}\text{C}$ at Range of -55 to $+150^{\circ}\text{C}$
Self Heating Effects	$\pm .1^{\circ}\text{C}$ Ambient Air

Temperature Compensation: True RH = Sensor RH/(1.0546-0.00216T) T in $^{\circ}\text{C}$ (True RH = Sensor RH/(1.093-0.0012T) T in $^{\circ}\text{F}$)

Note: The Temperature Compensation is NOT factored in with the humidity displayed on the 6520.

Figure 3 – Temp/Humidity and Pressure Sensor Layout

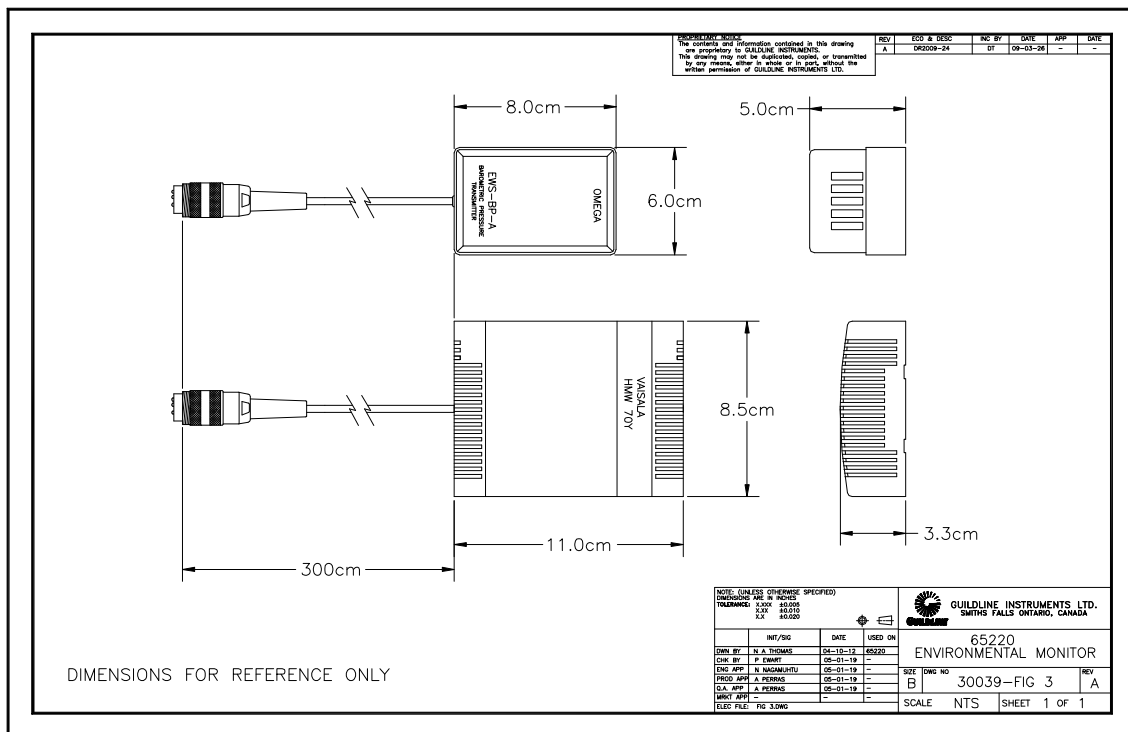

65220 ENVIRONMENTAL MONITOR (CON'T)

Pressure Sensor (Figure 4)

The piezoresistive transducer is a state-of-the-art monolithic silicon pressure sensor designed for a wide range of applications, but particularly those employing a microcontroller or microprocessor with A/D inputs.

This patented, single element transducer combines advanced micromachining techniques, thin-film metallization, and bipolar processing to provide an accurate, high level analog output signal that is proportional to the applied pressure

Integrated Pressure Sensor Specifications

0 to 100 kPa (0 to 14.5 psi): 15 to 115 kPa (2.18 to 16.68 psi)
0.2 to 4.7 Volts Output



Figure 4
Pressure Sensor

65221 SURFACE VOLUME RESISTIVITY TEST FIXTURE (Reference Figure 5)

This optional accessory allows the 6520 user to make direct measurement of volume resistivity up to $10^{18}\Omega\cdot\text{cm}$ (on samples 0.1cm thick) and surface resistivity up to $10^{17}\Omega/\text{square}$, in accordance with ASTM procedures. The test fixture is supplied with all the necessary interconnect cables for the 6520. A simple series of keystrokes on the 6520 front panel controls starts the measurement process.

Resistivity Fixture Device Data:

Operating Temperature: -30° to $+85^{\circ}\text{C}$
Operating Humidity: 65% R.H. (up to 35°C , de-rate 3% R.H./ $^{\circ}\text{C}$ above 35°C .)
Storage Temperature: -25° to $+85^{\circ}\text{C}$.
Dimensions: 108mm high \times 165mm wide \times 140mm deep (4 1/4in \times 6 1/2 in \times 5 1/2 in).
Weight: 1.45kg (3.19 lbs).

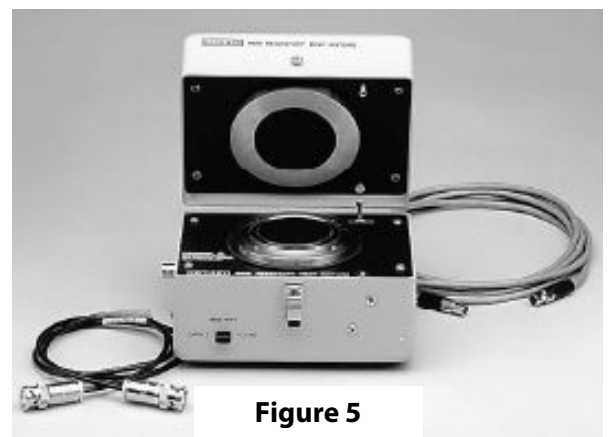

Figure 5

65222 LARGE SAMPLE ENCLOSURE (Reference Figure 6)

The 65222 large sample enclosure is designed to set test instrumentation inside a protective enclosure that eliminates affects due to the environment such as air flow, fast temperature, and others. The very large size of this enclosure will allow for example our 100Teraohm 7 dial decade standard to be set inside the unit and close the lid. A side cable entry port allows for the 6520 cables to be inserted through while the lid is closed.

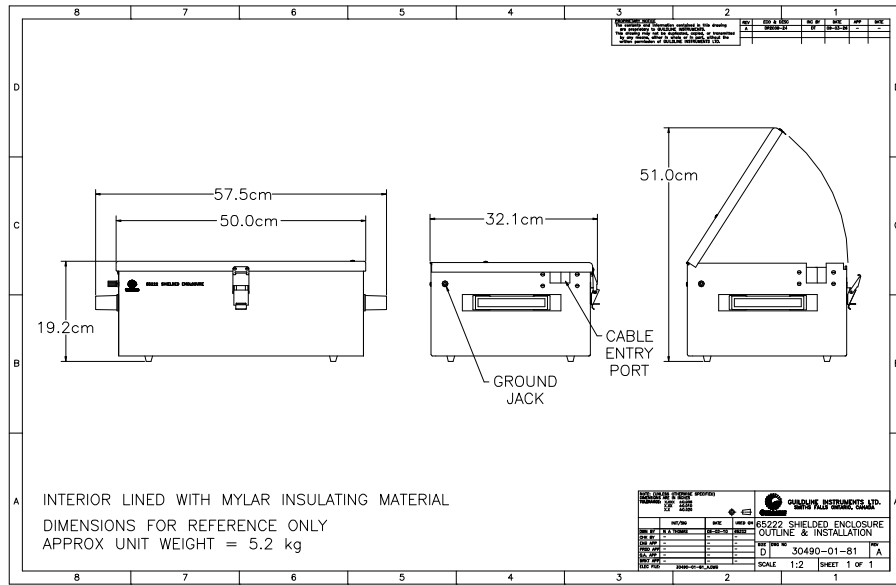

Figure 6

65223 SHIELDED SAMPLE ENCLOSURE (Reference Figure 7)

The model 65223 Small Enclosure provides a stable shielded environment for measuring high resistances and the leakage resistance of capacitors. The sample capacitor should be connected between the "Source" and "C" terminals. This inserts a 10 Mega ohm resistor in series with the Capacitor to limit inrush currents.

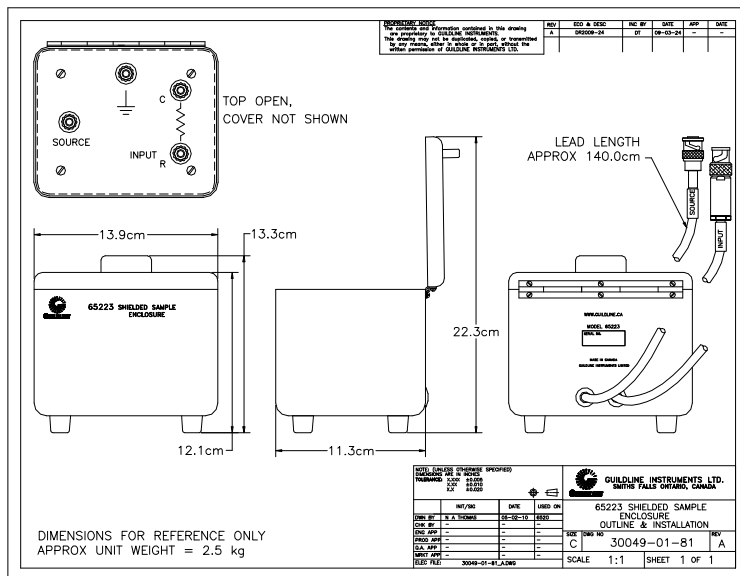

Figure 7

6520 Option Description

MODEL 65224 ZERO LINK

The 65224 Zero Link Set consists of the following components. Note that the 65224 Zero Link Set is also included in the 65226 Calibration Kit parts.

Qty	Part Number	Description
1	059-34521	connector, triax M, 3 lug
1	059-34010	connector, MHV M
1	903-00317	label 1.5x1.25"
1	996-00058	14" cable, coax RG58

MODEL 65225 LEAD SET

The 6520 includes a cable that has a standard BNC End (connects to 6520 Source Input) to a Male "N" connector which is the standard input for the Guildline 9336 and 9337 Source (Female "N" Connection). The 6520 standard cable set also includes one cable with a Triax End (Connects to 6520 Input) to Male "N" type cable which is the standard input for the Guildline 9336 and 9337 "Output" connections.

The 65225 lead set includes the additional cables, connectors and adaptors.

Qty	Part Number	Description
1	30053.02.21	1.8m coax cable - MHV M to Type N,F
1	30054.02.21	1.8m triax cable - M to Type N F
1	30055.01.21	1.8m coax cable - MHV M both ends
1	30046-01-21	1.8m cable - MHV M to Plug
1	054-20504	alligator clip, red
1	054-20505	alligator clip, black
1	997-09223	0.9m cable, triax M to alligator
1	997-09224	0.9m cable, Triax M to Triax M
1	003-23237	adapter, Triax F to Triax F

MODEL 65226 CALIBRATION KIT

The 65226 Kit consists of the following components. Note that this kit includes a 9936-100M Resistance Standard (Calibrated at three temperature points) and the 65224 Zero Link.

Qty	Part Number	Description
1	30046-01-21	cable, MHV M to plug 1.8m
1	20020.03.40	9336/100M Standard Resistor
1	30045-01-21	65224 Zero Link
1	30007-01-65	Calibration procedure 6520
1	GI2003002A	Application Note 6520
1	022-01213	Case

9336/9337 STANDARD RESISTORS

The Guildline 9336 series of Resistance Standards are designed as very high stability calibration laboratory standards for accurate resistance calibration in air, between 10 Megohms and 10 Petaohms.

The resistor elements are securely mounted to the inside of a rugged hermetically sealed, shielded, aluminium enclosure. A pair of input/output Type N connectors provide the termination for the standard. The "SOURCE" connector connects to the power supply of the measurement system, while the "OUTPUT" connector



6636 TEMPERATURE STABILIZED RESISTANCE STANDARDS

The 6636 contains specified values from 100M to 100 Tera Ohms in a specially designed, temperature controlled environment. This environment greatly reduces uncertainties associated due to effects of temperature and increases overall the stabilities of the resistive elements. The 6636 Standard can be used in an operating environment of 23°C : ±5°C.



6520 Ordering Information

6520	Programmable Digital Teraohmmeter
TeraCal™	Data Acquisition software (included)* * Requires a Windows 9X/NT computer with National Instruments IEEE-488.2 interface (not included)
TM6520	Technical Manual (included)
	Certificate of Calibration (included)
/RC	Report of Calibration (extra charge)

6520 Options and Accessories

65201	Penn Airborne Adapter
65220	Environmental Monitor Set
65221	Surface/Volume Resistivity Test Fixture
65222	Large Shielded Sample Enclosure
65223	Small Shielded Sample Enclosure
65224	Zero Link
65225	Lead Set
65226	Calibration Kit
6636	Temperature Stabilized Resistance Standard
9336-x	Standard Resistor (Specify Value 10M to 100G Ω)
9337-x	Standard Resistor (Specify Value 1T to 1P Ω)
6675A-01A	IEEE-488.2 Interface Card for PCI slot
6675A-02A	2 Meters Double Shielded IEEE-488.2 Interface Cable
6675A-02B	1 Meter Double Shielded IEEE-488.2 Interface Cable

Guildline is distributed by:

Guildline Instruments Limited

P.O. Box 99, 21 Gilroy Street
Smiths Falls, Ontario Canada K7A 4S9
Phone: (613) 283-3000 Fax: (613) 283-6082
Web: www.guildline.com
Email: sales@guildline.com