

Errata

Title & Document Type: 11664C Detector Adapter Operating and Service Manual

Manual Part Number: 11664-90068

Revision Date: 1987-10-01

HP References in this Manual

This manual may contain references to HP or Hewlett-Packard. Please note that Hewlett-Packard's former test and measurement, semiconductor products and chemical analysis businesses are now part of Agilent Technologies. We have made no changes to this manual copy. The HP XXXX referred to in this document is now the Agilent XXXX. For example, model number HP8648A is now model number Agilent 8648A.

About this Manual

We've added this manual to the Agilent website in an effort to help you support your product. This manual provides the best information we could find. It may be incomplete or contain dated information, and the scan quality may not be ideal. If we find a better copy in the future, we will add it to the Agilent website.

Support for Your Product

Agilent no longer sells or supports this product. You will find any other available product information on the Agilent Test & Measurement website:

www.tm.agilent.com

Search for the model number of this product, and the resulting product page will guide you to any available information. Our service centers may be able to perform calibration if no repair parts are needed, but no other support from Agilent is available.

OPERATING AND SERVICE MANUAL

**HP 11664C
DETECTOR
ADAPTER**

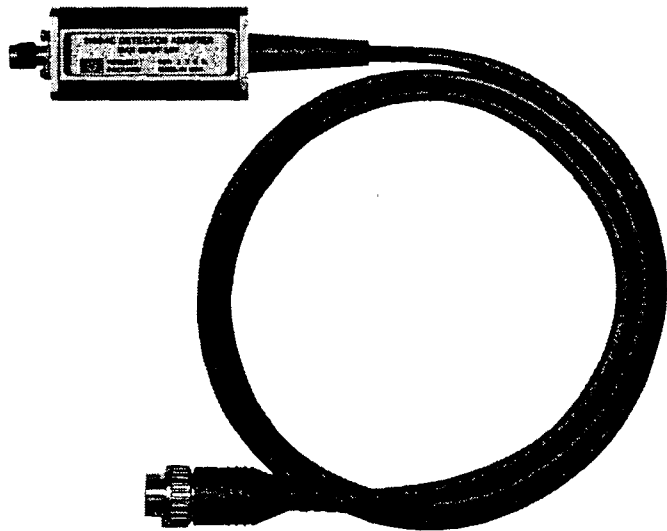

CERTIFICATION

Hewlett-Packard Company certifies that this product met its published specifications at the time of delivery from the factory. Hewlett-Packard further certifies that its calibration measurements are traceable to the United States National Bureau of Standards, to the extent allowed by the Bureau's calibration facility, and to the calibration facilities of other International Standards Organization members.

WARRANTY

This Hewlett-Packard instrument product is warranted against defects in material and workmanship for a period of one year from date of delivery. During the warranty period, Hewlett-Packard Company will, at its option, either repair or replace products which prove to be defective.

For warranty service or repair, this product must be returned to a service facility designated by HP. Buyer shall prepay shipping charges to HP and HP shall pay shipping charges to return the product to Buyer. However, Buyer shall pay all shipping charges, duties, and taxes for products returned to HP from another country.

HP warrants that its software and firmware designated by HP for use with an instrument will execute its programming instructions when properly installed on that instrument. HP does not warrant that the operation of the instrument, or software, or firmware will be uninterrupted or error free.

LIMITATION OF WARRANTY

The foregoing warranty shall not apply to defects resulting from improper or inadequate maintenance by Buyer, Buyer-supplied software or interfacing, unauthorized modification or misuse, operation outside of the environmental specifications for the product, or improper site preparation or maintenance.

NO OTHER WARRANTY IS EXPRESSED OR IMPLIED. HP SPECIFICALLY DISCLAIMS THE IMPLIED WARRANTIES OF MERCHANTABILITY AND FITNESS FOR A PARTICULAR PURPOSE.

EXCLUSIVE REMEDIES

THE REMEDIES PROVIDED HEREIN ARE BUYER'S SOLE AND EXCLUSIVE REMEDIES. HP SHALL NOT BE LIABLE FOR ANY DIRECT, INDIRECT, SPECIAL, INCIDENTAL, OR CONSEQUENTIAL DAMAGES, WHETHER BASED ON CONTRACT, TORT, OR ANY OTHER LEGAL THEORY.

ASSISTANCE

Product maintenance agreements and other customer assistance agreements are available for Hewlett-Packard products.

For any assistance, contact your nearest Hewlett-Packard Sales and Service Office. Addresses are provided at the back of this manual.

HP 11664C DETECTOR ADAPTER

SERIAL NUMBERS

This manual applies directly to HP 11664 detector adapters with a serial number of 2357 and above.

For additional information concerning serial numbers, see INSTRUMENTS COVERED BY THE MANUAL the General Information section of this manual.

©Copyright HEWLETT-PACKARD COMPANY 1987
1400 FOUNTAINGROVE PARKWAY, SANTA ROSA, CA 95403 U.S.A.

MANUAL PART NO. 11664-90068
Microfiche Part Number 11664-90069

Printed: OCTOBER 1987



**HEWLETT
PACKARD**

TABLE OF CONTENTS

HP 11664C

Detector Adapter

GENERAL INFORMATION

Introduction	1
Safety Considerations	1
General	1
Safety Symbol	1
Description	1
Options	1
Typical Operating Characteristics	1, 2
Instruments Covered By This Manual	2
Accessories	2
Equipment Required But Not Supplied	3
Recommended Test Equipment	3
Ordering A Manual/Microfiche	4

INSTALLATION

Initial Inspection	5
Preparation For Use	5
Power Requirements	5
Detector Lead Identification	6
Mating Connector	6
Connecting the HP 11664C	6
Operating Environment	7
Storage and Shipment	7
Returning the Product for Service	7

OPERATION

Introduction	9
Features	9
Operating Precautions	9
Operator's Adjustments	11
Setting Bias Switches	11
Input Impedance and Gain Adjustments	12
Operator's Verification	15

REPLACEABLE PARTS

Replaceable Parts List Description	17
Section Contents	17
Information	17
Ordering Information	17
Replaceable Parts List	19

MANUAL BACKDATING CHANGES

What Is Manual Backdating?	21
Revision History	21
Change A	21, 23

SERVICE

Introduction	25
Repair	25
Printed Circuit (PC) Board and Cable Removal	25
Soldering Cable Leads	25
Installing the PC Board Assembly	25
Hewlett-Packard Servicing	26
Theory of Operation	26
A1 Compensation Amplifier Circuit Description	26
Troubleshooting	26

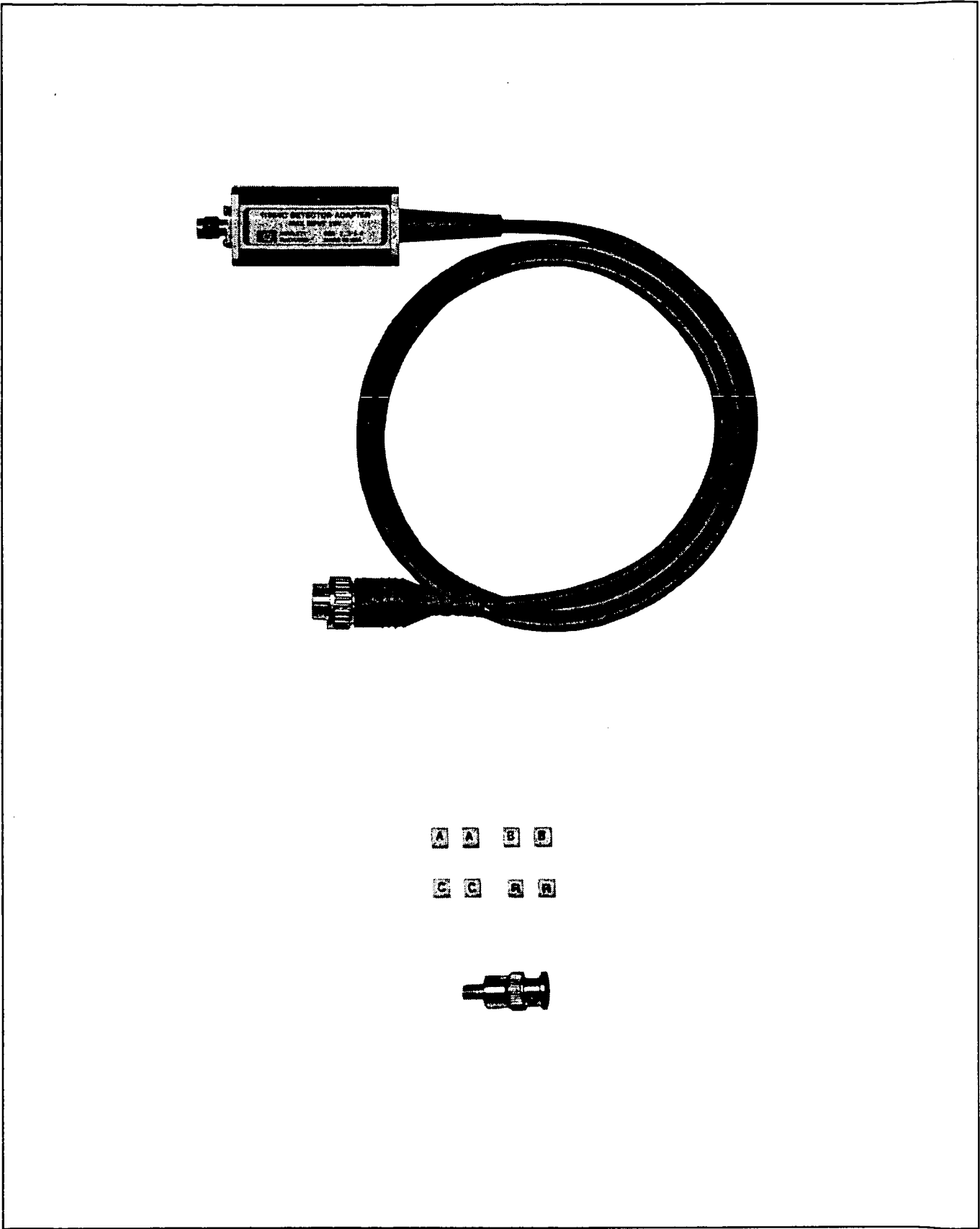

Figure 1. HP 11664C and Accessories Supplied

General Information

INTRODUCTION

This manual contains information required to operate, test and service the HP 11664C detector adapter. Figure 1 shows the product and the accessories that are supplied with it.

Operating information is provided in the Operation Section. Operator's Adjustments contain instructions for ensuring that your detector adapter is operating correctly. Repair information is located in the Service Section.

SAFETY CONSIDERATIONS

General

There are no hazardous voltages in the HP 11664C.

Safety Symbol



A CAUTION calls attention to an operating procedure, practice, etc., that, if not correctly performed or adhered to, can cause damage to (or destruction of) part or all of the HP 11664C. Do not continue past a CAUTION until you fully understand and meet the stated conditions.

DESCRIPTION

The HP 11664C detector adapter is used to adapt any standard AC diode detector output for display on the HP 8756A or 8757A scalar network analyzers. The detector adapter enables the analyzer to measure modulated (AC) test signals. The ability to use a standard diode detector extends the frequency range of the network analyzer to that of the detector used.

Options

Option 910, Extra Manual. The standard detector adapter is supplied with one operating and service manual. Option 910 adds a second manual.

Typical Operating Characteristics

Table 1 lists the HP 11664C typical operating characteristics.

Table 1. Typical Operating Characteristics

Frequency Response:	Dependent on the external detector.
Compatible Detectors:	Low barrier Schottky, point contact crystal, or planar doped barrier detectors (positive or negative). The HP 11664C provides internal $\pm 50 \mu\text{A}$ bias capability.
Dynamic Range:	Dependent on the external detector.
Maximum Input Voltage:	10V peak-to-peak.
Dimensions:	Cable length is 122 cm (48 in).
Net Weight:	0.17 kg (6 oz.)

INSTRUMENTS COVERED BY THIS MANUAL

Each HP 11664C detector adapter has a unique serial number. This manual applies to HP 11664Cs with a serial number of 2357 and above.

A detector adapter manufactured after the printing of this manual may require a Manual Changes Supplement to document instrument change information. When required, the supplement is included with the instrument manual. In addition to change information, the supplement contains information that corrects errors in the manual.

To keep this manual as current as possible, Hewlett-Packard recommends that you periodically request the latest Manual Changes Supplement. The supplement for this manual is keyed to its print date and part number, which appear on this manual's title page. Complimentary copies of the supplement are available from your local Hewlett-Packard office.

ACCESSORIES

The following accessories are available for the HP 11664C:

- HP 11679A, 7.6 metres (25 foot) extension cable.
- HP 11679B, 61 metres (200 foot) extension cable.

EQUIPMENT REQUIRED BUT NOT SUPPLIED

To make reflection and transmission measurements you will need:

- One or more separate (zero biased, crystal, silicon or gallium arsenide) detectors (such as the HP 8470 series).
- One HP 11664C for each detector.
- One connector adapter (if required) for each detector (see Table 2).
- A scalar network analyzer, such as the HP 8756A, or 8757A.
- An RF source covering the frequency range of the detector(s) used, such as the HP 8350 (with appropriate RF plug-in), HP 8340, or HP 8341.
- The RF source must be capable of 27.778 kHz squarewave amplitude modulation. The HP sources listed above are so equipped. If you use an RF source that cannot provide the modulated signal directly, you must use an external modulator (such as the HP 11665B).
- A dual directional coupler (or two single directional couplers) or a directional bridge.

RECOMMENDED TEST EQUIPMENT

The equipment required for testing the HP 11664C is listed in Table 2. Other equipment may be substituted if it meets or exceeds the critical specifications indicated in the table.

Table 2. Recommended Test Equipment

Instrument	Critical Specifications	Recommended Model	Use*
Network Analyzer	11664C AC compatible	HP 8757A	O,A,S
Sweep Oscillator	Compatible with network analyzer	HP 8350B with RF plug-in or HP 8341A or HP 8340A	O,A
Digital Voltmeter		Any	A,S
Step Attenuator	0 to 70 dB in 10 dB steps	**	O
Detector	Low Barrier (Zero Bias) Frequency: same as sweep oscillator	**	O
Power Meter		HP 436A	O
Power Sensor		**	O
Adjustment Tool	Fits adjustment potentiometers	HP 8710-1300	A
*O=Operator's Check A=Adjustments S=Service **Dependent on the diode detector's frequency range.			

ORDERING A MANUAL/MICROFICHE

On the title page of this manual is a manual part number and a microfiche part number. Both can be used to order extra copies of this manual.

Microfiche are 10 X 15 cm (4 X 6 in) microfilm transparencies. Each microfiche contains reduced photocopies of the manual pages. Also included in the microfiche package are the latest manual changes supplement and pertinent service notes.

The manual part number also appears on the back cover, in the lower left hand corner.

INITIAL INSPECTION

If the shipping container or cushioning material is damaged, keep it until the contents of the shipment are checked for completeness, and the instrument is checked both mechanically and electrically.

1. Check the package for completeness. Figure 1 shows the items you should receive.
2. Check the connector, cable and body for mechanical damage.
3. Adjust and test the detector adapter electrically. Refer to Operator's Adjustments and Operator's Verification procedures given later in the Operation Section.

Notify your nearest Hewlett-Packard office if any of the following conditions exist:

- The instrument does not pass the operator's verification or can not be adjusted properly.
- The shipping contents are incomplete.
- There is mechanical damage or defect.

Also, notify the carrier if the shipping container is damaged or if the cushioning material shows signs of stress. Keep all shipping materials for the carrier's inspection. Hewlett-Packard will arrange for repair or replacement without waiting for a claim settlement.

PREPARATION FOR USE



The detector adapter is susceptible to damage from electrostatic discharge (ESD). ESD damage is most likely to occur as the device is connected or disconnected. Protect the device by wearing a ground strap (HP Part Number 9300-1117). Before you connect a cable to the diode detector, always short the cable's center conductor to instrument ground.

NEVER touch the center contacts of the input connector. Work on an anti-static table mat (HP Part Number 9300-0797).

Do **NOT** apply more than 9.2 cm/kg (8 in/lb) of torque when tightening the input connector. Greater surface torque may deform the mating surface.

Power Requirements

Power for the detector adapter is supplied by the scalar network analyzer. Each detector requires approximately 0.5 watts.

Detector Lead Identification

Use the furnished coded cable clips (cable marker kit) to identify leads when you use two or more detector adapters. Place matching clips on both ends of the same detector cable.



Connecting a detector to the HP 11664C with the bias switched improperly may damage the detector. Before connecting the detector to the adapter, read the Operator's Adjustment paragraph provided in the Operation Section.

Mating Connector

The HP 11664C input connector is an SMA male type. This connector should mate directly with most detector output connectors; for best performance, the detector adapter should be connected directly to the detector. If, however, the detector you are using does not mate directly with the HP 11664C, an adapter can be used, but you must be aware that several factors can effect the accuracy of your measurements:

- Be sure that all connectors are clean and undamaged. A cleaning kit is available, order HP Part Number 92193Z. The kit includes compressed air, liquid freon, and foam swabs. Do not clean SMA connectors with cotton tipped (fibrous) swabs.

A mechanically defective connector makes low power level readings unstable; the analyzer trace may change greatly when the connector is touched or moved.



SMA connectors are not precision devices and may be out of mechanical tolerance even when new. A damaged connector will ruin a good connector on the very first connection. SMA connectors should be checked for conformance to mechanical tolerances before mating with 3.5 mm connectors. 3.5 mm connectors are easily damaged by an out-of-tolerance SMA connector. Never assume an SMA connector is within tolerance, not even when it is new. Measure SMA connectors periodically to check their condition. Refer to the Connector Care Manual, HP Part Number 08510-90064, for instructions.

- Putting a length of coaxial cable between the detector and the HP 11664C can cause errors at low power levels, due to loss through the cable.

Connecting the HP 11664C

Connect the detector adapter to the network analyzer as follows:

1. Connect the detector adapter to the detector by turning the male connector OUTER shell clockwise. Do not allow the center conductor to turn.
2. Insert the multi-pin connector into the network analyzer mating connector. The HP 11664C connector is keyed; insert the plug with the key downward.
3. Secure the multi-pin connector in the analyzer by turning the OUTER shell clockwise.

OPERATING ENVIRONMENT

The HP 11664C detector adapter operates within the following environmental limits:

Temperature: 0°C to +55°C

Humidity: Up to 95%.

Altitude: Up to 7,620 m (25,000 ft).

Provide protection from temperature extremes. Condensation may occur within the unit if it is exposed to temperature extremes or to sudden increases in humidity.

STORAGE AND SHIPMENT

Storage or shipment environmental requirements are the same as the operating environmental requirements given above, with the following exception:

Temperature: -25°C to +75°C

Returning the Product for Service

If you ship the HP 11664C to a Hewlett-Packard office or service center, please fill out a blue service tag, located at the end of this manual. Include the following information:

1. Your company name and address.
2. The technical contact person within your company, and their complete phone number.
3. The complete model and serial number of the instrument.
4. The type of service required.
5. Any other information that may expedite service.

Wrap the detector (with blue service tag) in heavy paper or anti-static plastic, and place in a strong shipping container such as a double-wall carton made of 350-lb test material. Pack with shock-absorbing material, a 7.5 to 10 cm (3 to 4 in) layer, around all sides of the instrument to provide a firm cushion and to prevent movement inside the container. Seal the shipping container securely and mark the shipping container **FRAGILE**.

When making inquiries, either by correspondence or by telephone, please refer to the instrument by model number and full serial number.



As a precaution, discharge the HP 11664C by grounding the center conductor.

NEVER touch the detector or the HP 11664C center contacts.

INTRODUCTION

This section contains information concerning the operation of the HP 11664C detector adapter.

FEATURES

Figure 2 details the features of the HP 11664C.

OPERATING PRECAUTIONS

- Ensure that your HP 8757A firmware is revision 2.0 or greater. To find the firmware revision, press [PRESET] on the HP 8757A. The firmware revision will be displayed on the screen.
- Read and observe all **CAUTIONS**.
- **DO NOT** tighten the input connector with a wrench unless it is a torque wrench set at 8 in/lb.

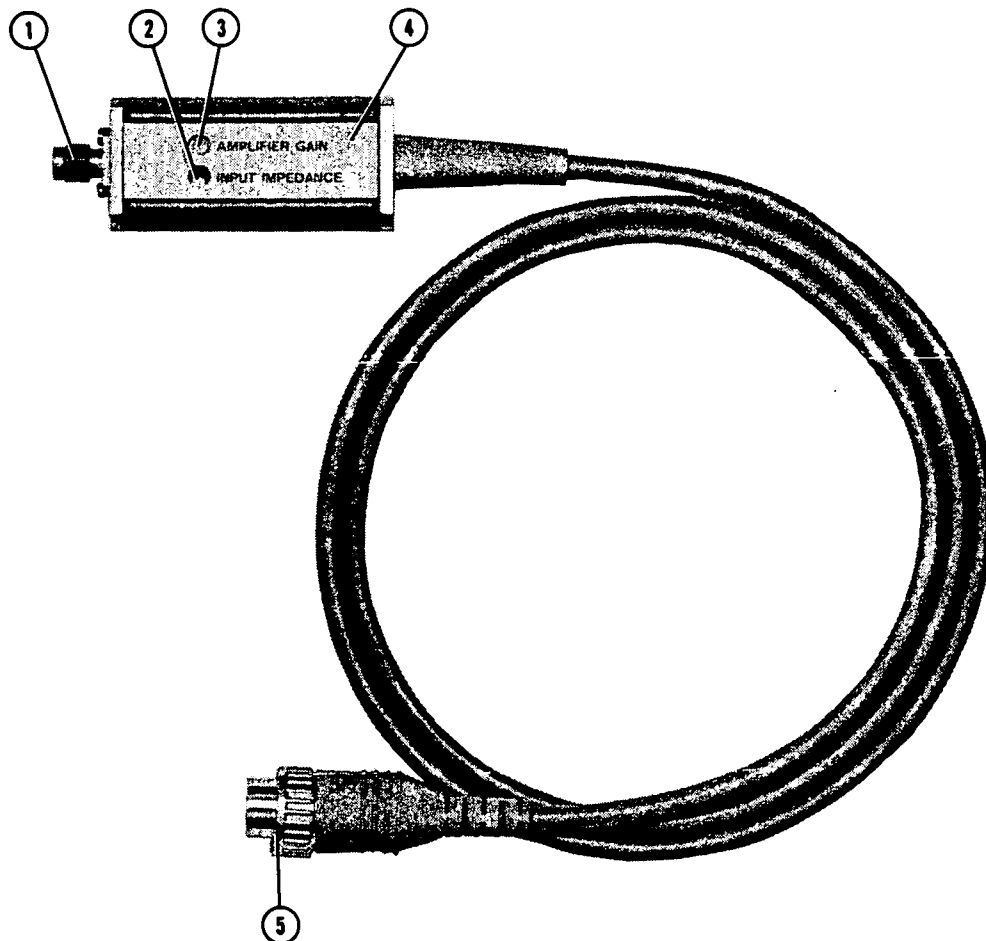

1. **INPUT CONNECTOR.** This connector (SMA male) accepts the detected RF signal from the diode detector.
2. **INPUT IMPEDANCE.** An adjustment to match the characteristics of the detector to those of the network analyzer.
3. **AMPLIFIER GAIN.** An adjustment to match the characteristics of the detector to those of the network analyzer.
4. **BIAS SWITCHES.** Two switches under the cover provide a positive (S1-1) or negative (S1-2) 50 μ A of bias current at the HP 11664C input connector.
5. **DC CONNECTOR.** This connector supplies the necessary DC supply voltage for the HP 11664C and conducts the detector output signal to the network analyzer.

Figure 2. HP 11664C Features

OPERATOR'S ADJUSTMENTS

Setting Bias Switches



The HP 11664C is capable of providing a bias current (positive or negative polarity) from its input connector. Selecting the incorrect bias (switches 1 or 2) may result in damage to the detector. Avoid this problem by performing the following procedure.

1. Connect the HP 11664C to the HP 8757A without a detector connected to it. Refer to Figure 3. Turn the INPUT IMPEDANCE potentiometer (R2) fully clockwise. Turn the HP 8757A power on and measure the voltage on the input connector of the HP 11664 (center pin to ground). Using this voltage, refer to Table 3 to determine how switches S1 and S2 are set.

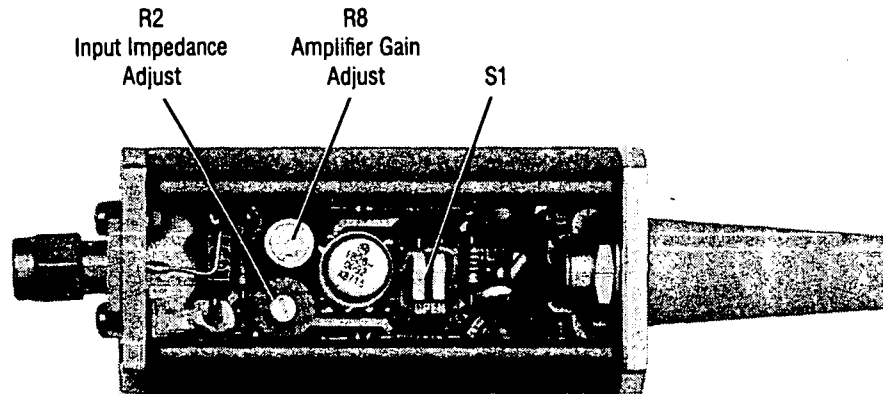

Figure 3. Adjustment Potentiometers and Switch Locations

Table 3. Input Connector Voltage vs S1 and S2 Position

Measured Voltage	S1 Position	S2 Position	Description
$< \pm 0.5V$	Open	Open	No Bias
$> +0.5V$	Closed	Open	Negative Detector/Positive Bias
More Negative Than $-0.5V$	Open	Closed	Positive Detector/Negative Bias

NOTE: Perform steps 2 and 3 only if S1 or S2 require different settings for your detector. Otherwise, proceed to step 4.

2. With the HP 11664C disconnected from any other devices, remove the two screws on each side of the cable (W1). Move the connector housing down far enough to slide the adjustment hole cover off. The bias switches (S1 and S2) should be set as indicated in Table 3 for the type of detector to be used.
3. With the switches set as needed, replace the cover and connector bracket

Input Impedance and Gain Adjustments

Equipment:

Scalar Network Analyzer	HP 8757A
Power Meter	HP 436A
Detector	Any
Sweep Oscillator	*
RF Plug-in (if required by sweep oscillator)	*
Step Attenuator (70 dB in 10 dB steps)	*
Power Sensor	*

*Use equipment within the frequency range of detector.

NOTE: Use a plastic adjustment tool, not a metal screwdriver, when making the adjustments described in this procedure.

1. Set up the equipment as shown in Figure 4, with nothing connected to the output of the step attenuator. Turn on the equipment and allow 30 minutes for warm up.
2. Center the HP 11664C AMPLIFIER GAIN potentiometer.
3. Turn the INPUT IMPEDANCE potentiometer five turns counter-clockwise, then one turn clockwise.

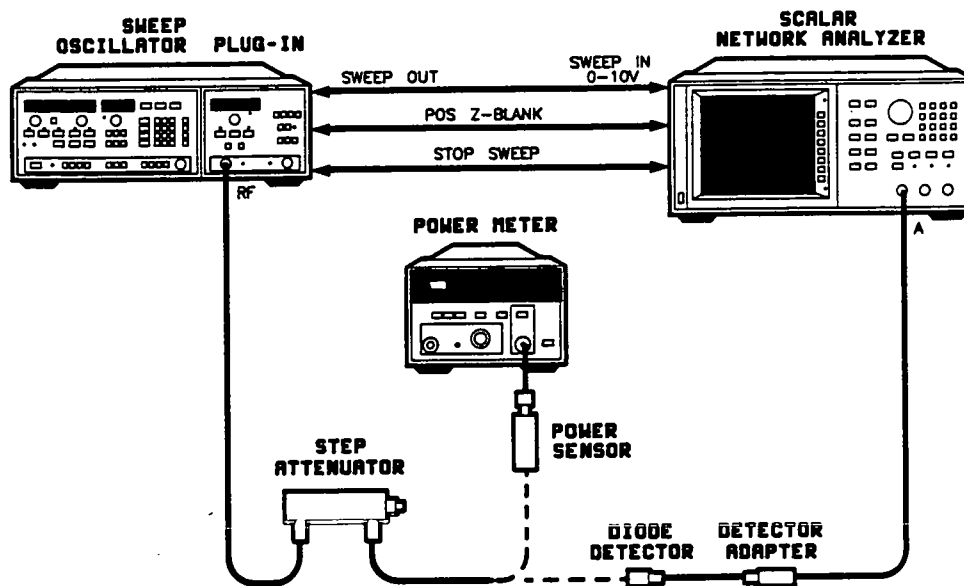

Figure 4. Test Setup

NOTE: Detectors with high sensitivity may be difficult to properly adjust at high power levels. If detector tracking is not accurate at the settings above +0 dBm, then adjust the HP 11664C starting with a maximum power output of 0 dBm.

4. Set the step attenuator to 0 dB (no attenuation). Zero the power meter and connect the power sensor to the output of the step attenuator.

ON THE SWEEP OSCILLATOR

5. Set the sweep oscillator's controls as follows:

Squarewave Modulation	OFF
Function	CW mode
Frequency	Any within range of the detector
Power	See step 6.

6. Adjust the sweep oscillator's output power to +10 dBm (measured by the power meter). The LEVELED light must be off. If this is not possible, select the maximum power at which the LEVELED light is off. Read this power on the power meter. This value will be referred to as **maximum power** throughout the rest of this procedure. Record this value in the space provided below:

Maximum Power = _____ dBm

7. Characterize the errors in the step attenuator by adding attenuation in 10 dB steps and subtracting the actual dBm reading from the expected reading. Record the error in the spaces provided below:

Step Attenuator Setting	Actual Value (dBm)	Expected Value (dBm)	Attenuator Error (dBm)
10 dB	_____	_____	_____
20 dB	_____	_____	_____
30 dB	_____	_____	_____
40 dB	_____	_____	_____
50 dB	_____	_____	_____
60 dB	_____	_____	_____
70 dB	_____	_____	_____

8. Remove the power sensor and place the HP 11664C and diode detector on the output of the step attenuator. Do not connect the HP 11664C to the diode detector with a cable, they should be connected directly to each other.

9. Turn on the sweep oscillator's 27.8 kHz modulation, and set the HP 8757A controls as follows:

Channel 1	A
Scale Factor	10 dB/Div
Channel 2	OFF
Reference/Reference Position	at Center Line
Cursor	ON

10. Set the step attenuator to 0 dB and adjust the AMPLIFIER GAIN potentiometer (R8) for a cursor reading equal to maximum power.
11. Set the step attenuator to 20 dB and adjust the INPUT IMPEDANCE potentiometer (R2) for a cursor reading equal to maximum power minus 20 dB. Take into account the step attenuator error at 20 dB.
12. These adjustments are iterative. Repeat steps 10 and 11 until the difference between the 0 dB and -20 dB attenuation readings is 20 dBm \pm 0.5 dBm. Take into account the attenuator error at -20 dB.

Operator's Verification

NOTE: The above procedure adjusted the detector adapter so the detector characteristics match those of the HP 8757A input. The following steps verify the linearity and noise level of the system. The test setup is the same as used in the above adjustment.

6. Set the step attenuator to 0 dB. The cursor reading should be within 2 dB of **maximum power**.
7. Increase the attenuation in 10 dB steps from 0 to -50 dB. The cursor reading should remain within 2 dB of the expected power level. Take into account known errors in the step attenuator at each setting.
8. Increase the attenuation to 70 dB. The cursor value should be below -40 dBm.

Replaceable Parts

REPLACEABLE PARTS LIST DESCRIPTION

Section Contents

- Table 4 – lists abbreviations used in the parts list.
- Table 5 – lists all replaceable parts in reference designator order.
- Table 6 – gives all the manufacturer's code numbers that are used in the parts list.
- Figure 5 – contains a parts illustration and parts listing for the mechanical parts in the detector adapter.

Information

The following information is given for each part:

- The Hewlett-Packard part number.
- The part number check digit (CD).
- The total quantity (Qty) used in the product.
- The description of the part.
- The five digit code of the typical manufacturer of the part.
- The manufacturer's part number for the part.

NOTE: The total quantity for each part is given only once, at the first appearance of the part in the list.

ORDERING INFORMATION

To order a part listed in the replaceable parts list, indicate the Hewlett-Packard part number (with check digit to ensure efficient processing) and the quantity desired. Address the order to the nearest Hewlett-Packard office.

To order a part that is not listed in the replaceable parts list, include the instrument model and serial number, the description and function of the part and the quantity desired. Address the order to the nearest Hewlett-Packard office.

Table 4. Reference Designators and Abbreviations

<p>REFERENCE DESIGNATORS</p> <p>A assembly C capacitor, carbon MP mechanical part U integrated circuit R resistor S switch W cable</p> <p>ABBREVIATIONS</p> <p>ADJ adjust ASSY assembly CER ceramic CD check digit</p>	<p>CM centimetre DIP dual-in-line package F farads, film FXD fixed G gram, giga=10⁹ GP general purpose H henries HEX hexagonal IC integrated circuit ID inside dimension IN inch K kilo=10³ m milli=10⁻³ M meg=10⁶ MET metal MFR manufacturer</p>	<p>MHz mega Hertz MTG mounting OP operational amplifier P pico=10⁹ PL plated QTY quantity RKR rocker SCR screw SI silicon SLDR solder TC temperature constant TRMR trimmer TRN turn U micro=10⁻⁶ VDCW dc working volts W watts</p>
---	--	---

Table 5. Replaceable Parts

Ref. Des.	HP Part Number	CD	Qty	Description	Mfr Code	Mfr Part Number
A1	11664-60021	2	1	BOARD ASSEMBLY; COMPENSATION AMPLIFIER	28480	11664-600021
A1C1	0180-2794	5	2	CAPACITOR-FXD 3.3UF ±20% 35VDC	02191	MD6-035-335-2019042
A1C2	0180-2794	5	2	CAPACITOR-FXD 3.3UF ±20% 35VDC	02191	MD6-035-335-2019042
A1MP1	0360-0535	0	3	TERMINAL-TEST POINT 0.330IN ABOVE	2848	0360-0535
A1MP2	11664-40001	6	1	VARIABLE RESISTOR HOLDER	28480	11664-40001
A1R1	0757-0280	3	2	RESISTOR:FXD 1K 1% 125W F TC=0±100	03292	C4-1/8-TO-1001-F
A1R2	2100-2655	1	1	RESISTOR:TRMR 100K 10% C TOP-ADJ 1-TRN	04568	82PR100K
A1R3	9656-0280	3	3	RESISTOR:FXD 1 K 1% 125W F TC=0±100	03292	C4-1/8-TO-1000-F
A1R4	0757-0438	3	1	RESISTOR:FXD 5110 1% 0.125W F TC=±100	03292	C4-1/8-TO-5111-F
A1R5	0698-3456	5	1	RESISTOR:FXD 287K 1% 0.125W F TC=0±100	03292	C4-1/8-TO-2873-F
A1R6	0698-3266	5	1	RESISTOR:FXD 237K 1% 0.125W F TC=0±100	03292	C4-1/8-TO-2373F
A1R7	0698-0083	8	1	RESISTOR:FXD 1960 1% 0.12W F TC=0±100	03292	C4-1/8-TO-1961-F
A1R8	2100-2216	0	1	RESISTOR:TRMR 5000 10% C-TOP-ADJ 1-TRN	04568	82PR5K
A1S1	3101-2061	6	1	SWITCH-RKR DIP-RKR-ASSY 2-1A 0.05A 30VDC	01380	2-435640-9
A1U1	1826-0092	3	1	IC OP AMP GP DUAL TO-99	01921	82301

Table 6. Manufacturers Code List

Mfr. No.	Manufacturers Name	Address	Zip Code
00000	ANY SATISFACTORY SUPPLIER		
01380	AMP INC	HARRISBURG PA	
01921	RCA CORP SOLID STATE DIV	SOMERVILLE NJ	08876
02191	CORNING/COMPONENTS INC	BIDDEFORD ME	
03292	CORNING GLASS WORKS (BRADFORD)	BRADFORD PA	16701
03316	SPECIALTY CONNECTOR CO INC	GREENWOOD IN	46227
04568	BECKMAN INSTRUMENT INC HELIP T DIV	FULLERTON CA	92634
28480	HEWLETT-PACKARD CO CORP HQ	PALO ALTO CA	93404

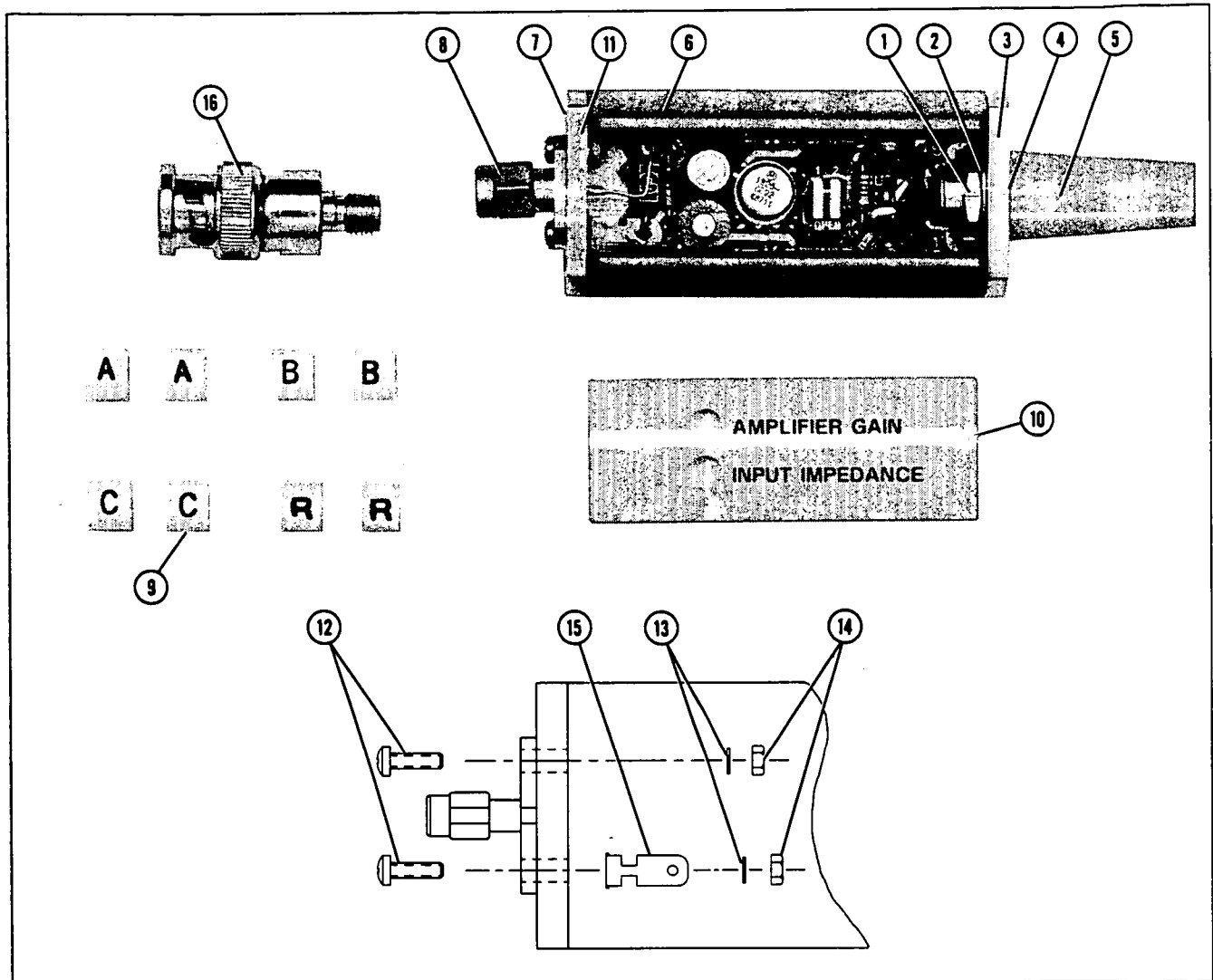

Item	HP Part Number	CD	Qty	Description	Mfr Code	Mfr Part Number
1	2950-0001	8	1	Nut-Hex-Double Chamfer	28480	2950-0001
2	2190-0016	3	1	Washer-Lock Internal Tooth 3/8 in 0.377-IN-ID	28480	2190-0016
3	11664-20004	7	1	End Plate (cable end) (Washer part of W1)	28480	11664-20004
4	8120-3804	2	1	Cable Assembly W1 (Includes P1)	28480	8120-3804
6	11664-20023	0	1	Detector Housing	28480	11664-20023
7	2200-0167	8	4	Screw-Machine 4-40	28480	2200-0167
8	1250-1980	9	1	SMA Connector	28480	1250-1980
9	5061-1044	9	1	Cable Marker Kit	28480	5061-1044
10	11664-00007	9	1	Bottom Cover	28480	11664-00007
11	11664-20041	2	1	End Plate (input connector end)	28480	11664-20041
12	0520-0129	8	2	Screw-Machine 256 .312 PNPD	28480	0520-0129
13	2190-0112	0	2	Washer-Lock .088 ID	28480	2190-0112
14	0610-0001	6	2	Nut-Hex 2-56	28480	0610-0001
15	0360-1190	2	1	Terminal Slidr Lug Lg .37	28480	0360-1190
16	1250-1700	1	1	Adapter, BNC (m) to SMA (f)	28480	1250-1700

Figure 5. Replaceable Parts Location

Manual Backdating Changes

WHAT IS MANUAL BACKDATING?

This manual has been written for and applies directly to HP 11664Cs beginning with the serial number listed on the title page. Earlier versions of HP 11664C differed from current models. This section describes differences between the earlier version and the current version.

REVISION HISTORY

Current production units are equipped with an SMA input connector. Units so equipped require no backdating changes.

On HP 11664Cs equipped with a BNC input connector, perform CHANGE A

CHANGE A

The original HP 11664C version was equipped with a BNC input connector, while the current version uses an SMA male connector.

Figure A contains the parts list and parts illustration for HP 11664C's equipped with a BNC input connector.

Kodak 2110 Duplicator Key Sheet



Inserts - Copy Onto

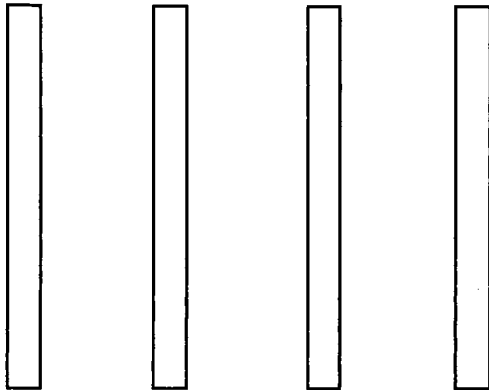

O P E R A T O R

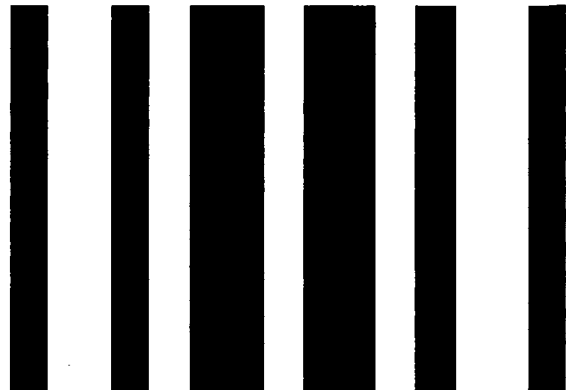

I N S T R U C T I O N S

- Place the Key Sheet in front of the original that is to be copied onto the insert.

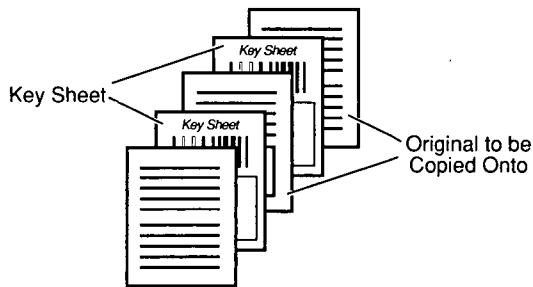

- Place your originals and Key Sheets in the feeder face up and make your Standard Features selections.

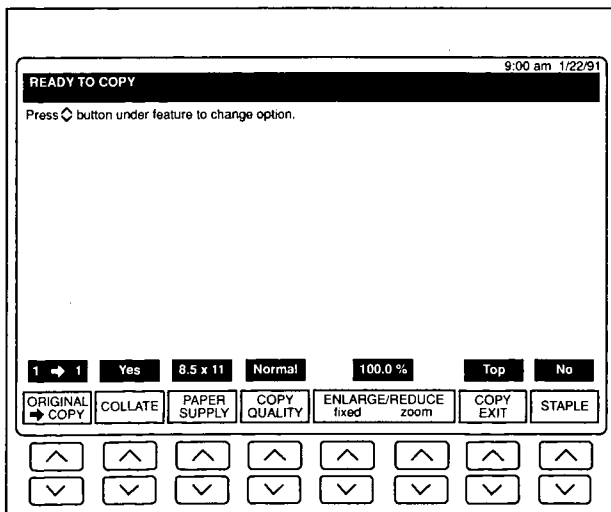

- Place the blank inserts into the upper paper supply.

- Press "Star" then "Start" to activate the Key Sheet.

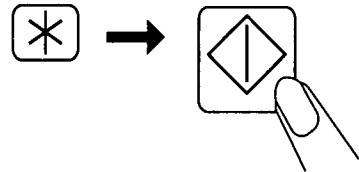

Note: The Key Sheets will exit into the positioner exit hopper. Copies of this Key Sheet may also be used.

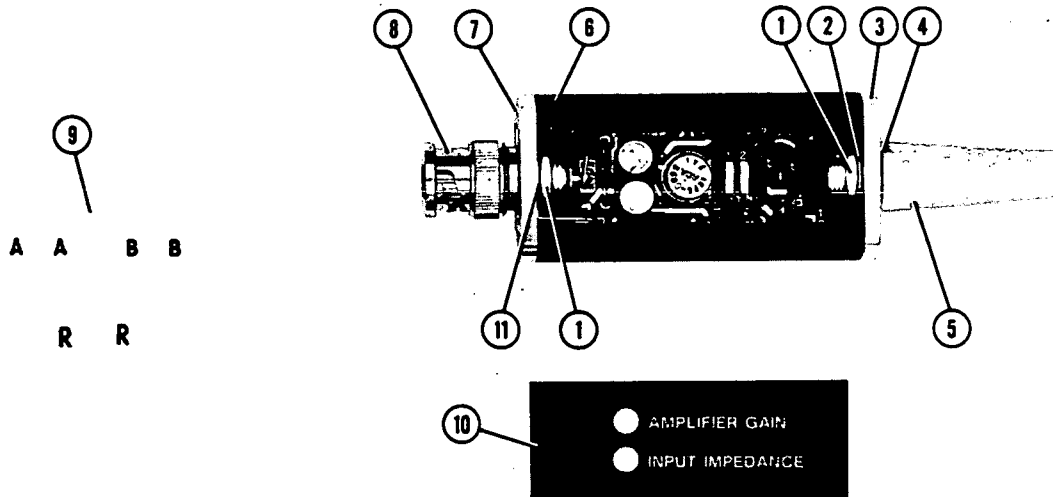

Item	HP Part Number	CD	Qty	Description	Mfr Code	Mfr Part Number
1	2950-0001	8	1	Nut-Hex-Double Chamfer	28480	2950-0001
2	2190-0016	3	1	Washer-Lock Internal Tooth 3/8 in 0.377-IN-ID	28480	2190-0016
3	11664-20004	7	1	End Plate (cable end)	28480	11664-20004
4				(Washer part of W1)		
5	8120-3804	2	1	Cable Assembly W1 (Includes P1)	28480	8120-3804
6	11664-20023	0	1	Detector Housing	28480	11664-20023
7	2200-0167	8	4	Screw-Machine 4-40	28480	2200-0167
8	11664-20022	9	1	Connector BNC	28480	11664-20022
9	5061-1044	9	1	Cable Marker Kit	28480	5061-1044
10	11664-00007	9	1	Bottom Cover	28480	11664-00007
11	11664-20041	2	1	End Plate (input connector end)	28480	11664-20041

Figure A. Replaceable Parts Location

INTRODUCTION

This section contains troubleshooting and repair information.

RECOMMENDED TEST EQUIPMENT

A list of the equipment required to test and maintain the HP 11664C is provided in Table 2.

REPAIR

The following procedures give step-by-step repair instructions for individual components where special care is necessary.

Printed Circuit (PC) Board and Cable Removal

To remove the PC board assembly or the cable assembly, proceed as follows:

1. Remove the two pozi-drive screws on the cable-end of the HP 11664C.
2. Slide the assembly out of the housing by carefully pulling on the cable until the adjustment hole cover can be removed.

Soldering Cable Leads

When desoldering or soldering cable leads to the PC circuit board assembly, use extreme care not to damage the plastic wire insulation. Use a heat sink, such as an alligator clip, between the insulation and the solder connection. Always use the minimum amount of heat necessary to make the connection.

Cable Wire Connections

- a. Shield wire to Ground (near E2).
- b. Violet wire to E4.
- c. Red wire to E2.
- d. White wire to E3

Installing the PC Board Assembly

When installing the printed circuit board assembly into the HP 11664C, check that all cable wires are connected to the assembly just before tightening the cable-end of the HP 11664C. These wires are delicate and should be checked each time the HP 11664C is disassembled.

Hewlett-Packard Servicing

If Hewlett-Packard service is required, fill out and attach one of the blue service tags provided at the end of this manual. Fill out the tag completely, giving full name and address, a contact person within the organization, and a description of the difficulty. This tag, when filled out completely, can help reduce the repair time.

THEORY OF OPERATION

A1 Compensation Amplifier Circuit Description

Refer to Figure 7, the circuit consists of a dual operational amplifier, U1A is used in the non-inverting mode and U1B in the inverting mode. The voltage gain of U1A is set by fixed resistors R4 and R3. The voltage gain of U1B is set by variable resistor R8 and fixed resistor R7. The input impedance to the amplifier is set by R1 and the variable resistor R2. The fixed resistor R1 is to insure that the input impedance to the adapter is never 0 Ohms, which may damage some detectors. C1 and C2 are power supply bypass capacitors.



Selecting the wrong bias for a detector could cause reverse bias of approximately 4 volts. This could result in permanent damage to the diode detector.

In some cases, diode detectors need bias currents to allow them to operate in an optimum square-law mode. Therefore R5 and S1-1 (when closed) will allow approximately +50 microamps of current to flow in the resistance between the positive supply and the low voltage that appears across the detector. This is used to bias negative detectors that require bias. Similarly, R6 and S1-2 (when closed) will develop a $-50 \mu\text{A}$ current for positive detectors that require bias.

The amplifier input impedance adjustment R2 establishes the transition point between square-law and linear detection modes of the detector being used. The corner point is set to match the shaping circuitry built into the HP 8756A and HP 8757A logger circuitry. The input impedance will be a function of the type of diode detector used. For a low barrier Schottky diode it will be 5 to 15 k Ω . For a point contact it will be 30 to 50 k Ω . Once the corner transition point is set by the input impedance potentiometer (R2), the overall gain is set by gain adjustment R8. This matches the detector adapter response curve to the logger circuit shaping in the scalar network analyzer.

TROUBLESHOOTING

Remove the detector from the HP 11664C input connector. Remove the adjustment cover and measure the following power supplies (refer to the schematic in Figure 7). Make sure the measured voltages are within the limits shown in Table 7.

Table 7. Power Supply Tolerances

Power Supply	Lower Limit	Upper Limit
+15V	+14.5	+15.5
-12.6V	-11.9	-13.1

If the supplies are within these limits then adjust R2 and R8 fully clockwise and check the voltage at TP1 with S1-1 and S1-2 in the position shown in table 8. Verify the proper voltages shown for TP1.

Table 8. TP1 Voltages

S1-1 Position	S1-2 Position	TP1 Voltage
OPEN	OPEN	-1.5 to +1.5V
CLOSED	OPEN	-9 to -12V
OPEN	CLOSED	+11 to +14V

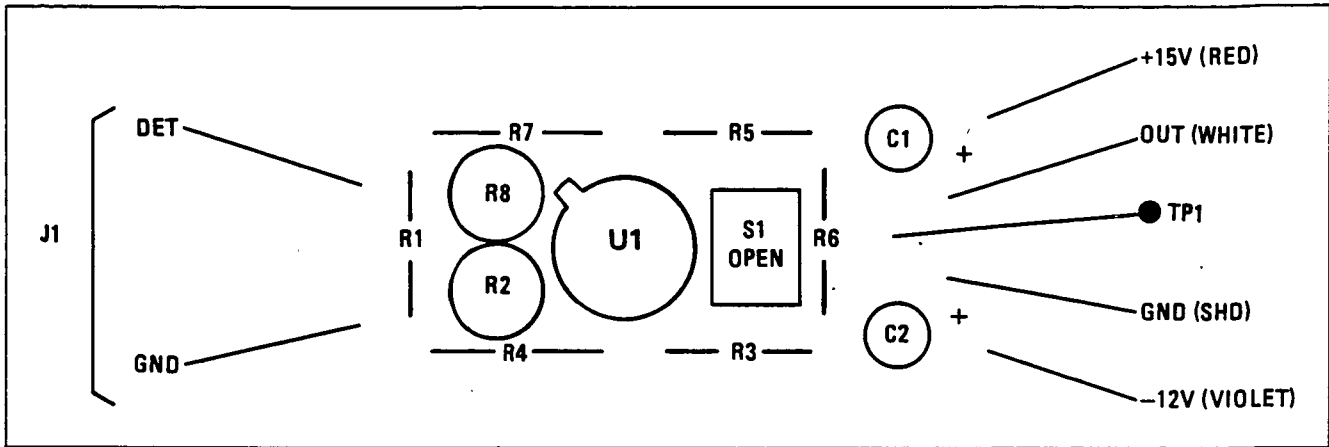

Figure 6. Component Location Diagram

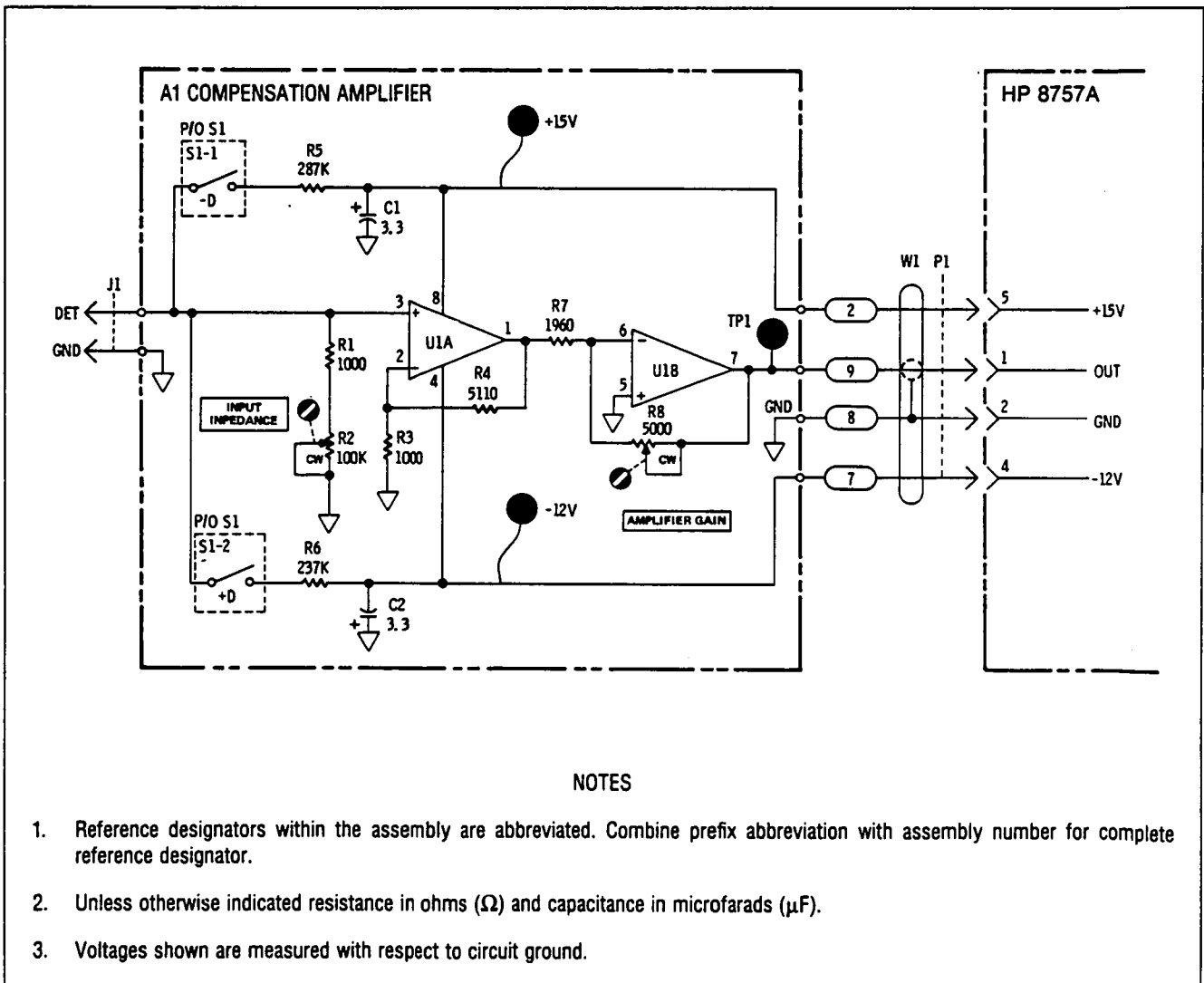

Figure 7. Schematic Diagram

Table 1-1. Hewlett-Packard Sales and Service Offices

US FIELD OPERATIONS		
<p>Headquarters Hewlett-Packard Co. 19320 Pruneridge Avenue Cupertino, CA 95014 (800) 752-0900</p>	<p>California, Northern Hewlett-Packard Co. 301 E. Evelyn Mountain View, CA 94041 (415) 694-2000</p>	<p>California, Southern Hewlett-Packard Co. 1421 South Manhattan Ave. Fullerton, CA 92631 (714) 999-6700</p>
<p>Colorado Hewlett-Packard Co. 24 Inverness Place, East Englewood, CO 80112 (303) 649-5512</p>	<p>Atlanta Annex Hewlett-Packard Co. 2124 Barrett Park Drive Kennesaw, GA 30144 (404) 648-0000</p>	<p>Illinois Hewlett-Packard Co. 5201 Tollview Drive Rolling Meadows, IL 60008 (708) 255-9800</p>
<p>New Jersey Hewlett-Packard Co. 150 Green Pond Rd. Rockaway, NJ 07866 (201) 586-5400</p>	<p>Texas Hewlett-Packard Co. 930 E. Campbell Rd. Richardson, TX 75081 (214) 231-6101</p>	
EUROPEAN FIELD OPERATIONS		
<p>Headquarters Hewlett-Packard S.A. 150, Route du Nant-d'Avril 1217 Meyrin 2/Geneva Switzerland (41 22) 780.8111</p>	<p>France Hewlett-Packard France 1 Avenue Du Canada Zone D'Activite De Courtaboeuf F-91947 Les Ulis Cedex France (33 1) 69 82 60 60</p>	<p>Germany Hewlett-Packard GmbH Hewlett-Packard Strasse 61352 Bad Homburg v.d.H Germany (49 6172) 16-0</p>
<p>Great Britain Hewlett-Packard Ltd. Eskdale Road, Winnersh Triangle Wokingham, Berkshire RG41 5DZ England (44 734) 696622</p>		
INTERCON FIELD OPERATIONS		
<p>Headquarters Hewlett-Packard Company 3495 Deer Creek Road Palo Alto, California, USA 94304-1316 (415) 857-5027</p>	<p>Australia Hewlett-Packard Australia Ltd. 31-41 Joseph Street Blackburn, Victoria 3130 (61 3) 895-2895</p>	<p>Canada Hewlett-Packard (Canada) Ltd. 17500 South Service Road Trans-Canada Highway Kirkland, Quebec H9J 2X8 Canada (514) 697-4232</p>
<p>China China Hewlett-Packard Company 38 Bei San Huan X1 Road Shuang Yu Shu Hai Dian District Beijing, China (86 1) 256-6888</p>	<p>Japan Hewlett-Packard Japan, Ltd. 1-27-15 Yabe, Sagamihara Kanagawa 229, Japan (81 427) 59-1311</p>	<p>Singapore Hewlett-Packard Singapore (Pte.) Ltd. 150 Beach Road #29-00 Gateway West Singapore 0718 (65) 291-9088</p>
<p>Taiwan Hewlett-Packard Taiwan 8th Floor, H-P Building 337 Fu Hsing North Road Taipei, Taiwan (886 2) 712-0404</p>		

