

Errata

Title & Document Type: 4342A Q-meter Operating and Service Manual

Manual Part Number: 04342-90006

Revision Date: March 1983

Thanks to John Day who provided this scanned copy

HP References in this Manual

This manual may contain references to HP or Hewlett-Packard. Please note that Hewlett-Packard's former test and measurement, semiconductor products and chemical analysis businesses are now part of Agilent Technologies. We have made no changes to this manual copy. The HP XXXX referred to in this document is now the Agilent XXXX. For example, model number HP8648A is now model number Agilent 8648A.

About this Manual

We've added this manual to the Agilent website in an effort to help you support your product. This manual provides the best information we could find. It may be incomplete or contain dated information, and the scan quality may not be ideal. If we find a better copy in the future, we will add it to the Agilent website.

Support for Your Product

Agilent no longer sells or supports this product. You will find any other available product information on the Agilent Test & Measurement website:

www.tm.agilent.com

Search for the model number of this product, and the resulting product page will guide you to any available information. Our service centers may be able to perform calibration if no repair parts are needed, but no other support from Agilent is available.

METROLOGY

JAN 21 1986

OPERATING AND SERVICE MANUAL

Q METER
4342A

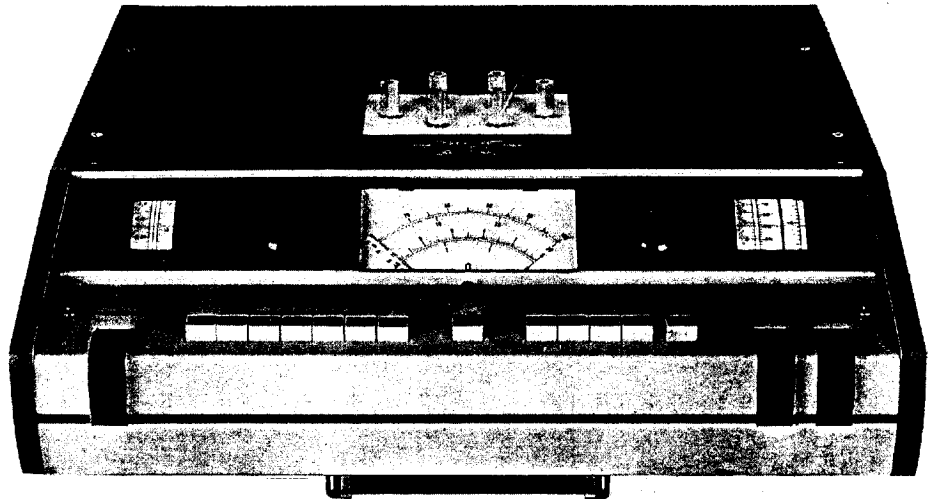

**HEWLETT
PACKARD**

COPYRIGHT AND DISCLAIMER NOTICE

Copyright – Agilent Technologies, Inc. Reproduced with the permission of Agilent Technologies Inc. Agilent Technologies, Inc. makes no warranty of any kind with regard to this material including, but not limited to, the implied warranties of merchantability and fitness for a particular purpose. Agilent Technologies, Inc. is not liable for errors contained herein or for incidental or consequential damages in connection with the furnishing, performance, or use of this material or data.

CERTIFICATION

The Hewlett-Packard Company certifies that this instrument was thoroughly tested and inspected and found to meet its published specifications when it was shipped from the factory. The Hewlett-Packard Company further certifies that its calibration measurements are traceable to the U.S. National Bureau of Standards to the extent allowed by the Bureau's calibration facility.

WARRANTY AND ASSISTANCE

All Hewlett-Packard products are warranted against defects in materials and workmanship. This warranty applies for one year from the date of delivery, or, in the case of certain major components listed in the operating manual, for the specified period. We will repair or replace products which prove to be defective during the warranty period provided they are returned to Hewlett-Packard. No other warranty is expressed or implied. We are not liable for consequential damages.

Service contracts or customer assistance agreements are available for Hewlett-Packard products that require maintenance and repair on-site.

For any assistance, contact your nearest Hewlett-Packard Sales and Service Office. Addresses are provided at the back of this manual.

OPERATING AND SERVICE MANUAL

MODEL 4342A Q METER

SERIAL NUMBERS COVERED

This manual applies directly to Model 4342A Q Meter with serial prefixed 1212J. Backdating changes in Section VII cover instruments with serials 1212J-00590 and below. Instruments with higher serial prefix will be covered in an Updating Manual Supplement at the first of the manual.

OPTIONS COVERED

This manual covers Option 001 instruments as well as the standard instrument.

© COPYRIGHT: YOKOGAWA-HEWLETT-PACKARD, LTD., 1970
9-1, TAKAKURA-CHO, HACHIOJI-SHI, TOKYO, JAPAN

Manual Part No. 04342-90009
Microfiche Part No. 04342-90059

Printed: MAR. 1983



TABLE OF CONTENTS

Section	Title	Page
I	GENERAL INFORMATION	1-1
	1-1. Introduction	1-1
	1-3. How the 4342A Measures	1-2
	1-8. Instruments Covered by Manual	1-2
	1-13. Specifications	1-3
	1-15. Accessories Supplied	1-3
	1-17. Accessories Available	1-3
	1-19. Options	1-3
II	INSTALLATION	2-1
	2-1. Introduction	2-1
	2-3. Initial Inspection	2-1
	2-4. Mechanical Check	2-1
	2-6. Performance Check	2-1
	2-8. Damage Claim	2-1
	2-11. Storage and Shipment	2-1
	2-12. Packaging	2-1
	2-13. Environment	2-1
	2-14. Power Connection	2-1
	2-15. Line Voltage	2-1
	2-16. Power Cable	2-1
III	OPERATION	3-1
	3-1. Introduction	3-1
	3-3. Panel Controls, Connectors and Indicators	3-1
	3-5. Q Measurement General	3-1
	3-8. Go/No-Go Function	3-1
	3-10. Measurement Terminals	3-5
	3-12. How to Connect Unknown	3-5
	3-14. Measurement Parameters and Connection Methods	3-5
	3-16. Direct Method Limitations	3-5
	3-18. Expansion of Measurement Ranges	3-6
	3-20. Capacitance Measurement	3-6
	3-22. Resistance Measurement	3-6
	3-24. High Q Measurement	3-7
	3-26. Supplemental Equipment Used in Parallel and Series Methods	3-7
	3-30. Basic Q Meter Measurements	3-11
	3-31. Quality Factor and Inductance Measurements (Direct Connection)	3-11
	3-33. Q Measurement	3-11
	3-35. ΔQ Measurement	3-12
	3-37. Inductance Measurement	3-12
	3-39. Inductance Measurement (at a desired frequency)...	3-13
	3-41. Measurement Requiring Corrections	3-13
	3-42. Effects of Distributed Capacitance	3-13
	3-45. Measuring Distributed Capacitance (Preferred Method)	3-14
	3-47. Measuring Distributed Capacitance (Approximate Method, $C_d \leq 10\text{pF}$)	3-15
	3-49. Correction for Q	3-16
	3-55. Parallel and Series Connection Measurement Methods ...	3-17
	3-56. General	3-17
	3-60. Additional Error Discussion	3-17
	3-64. Parallel Measurements	3-18
	3-65. High Inductance Measurement	3-18
	3-67. Low Capacitance Measurement ($< 450\text{pF}$)	3-19
	3-69. High Resistance Measurement	3-20
	3-71. Dielectric Measurement	3-21

Section	Title	Page
3-73.	Series Measurements	3-23
3-74.	Low Inductance Measurement	3-23
3-76.	High Capacitance Measurement ($\geq 450\text{pF}$)	3-24
3-78.	Self-resonant Frequency Measurement of High Capacitors	3-24
3-80.	Low Resistance Measurement	3-26
IV	THEORY OF OPERATION	4-1
4-1.	Introduction	4-1
4-3.	Q Determination and Measurement	4-1
4-6.	Simplified Block Diagram	4-1
4-8.	Block Diagram Description	4-1
4-10.	Oscillator and Impedance Converter (A1A1)	4-1
4-12.	RF Power Amplifier (A1A2)	4-1
4-14.	ALC Amplifier (P/O A8)	4-2
4-16.	Q/ Δ Q Range Attenuator (A3)	4-2
4-18.	Tuning Capacitor and Injection Transformer (A2)... ..	4-2
4-21.	RF Amplifier and Detector (A5)	4-2
4-24.	DC Amplifier (A6)	4-2
4-26.	Q Limit Selector (A7)	4-2
4-28.	Circuit Details	4-2
4-29.	LC Oscillator (P/O A1A1)	4-2
4-31.	Impedance Converter (P/O A1A1) and RF Power Amplifier (A1A2)	4-3
4-33.	ACL Amplifier (P/O A8)	4-3
4-35.	Q Range Attenuator (A3)	4-3
4-37.	Impedance Converter, RF Amplifier and Detector (A5)	4-3
4-39.	DC Amplifier (A6)	4-3
4-41.	Q Limit Selector (A7)	4-3
4-43.	Power Supply (P/O A8)	4-3
V	MAINTENANCE	5-1
5-1.	Introduction	5-1
5-3.	Test Equipment Required	5-1
5-5.	Q Accuracy Considerations	5-1
5-7.	Option	5-1
5-9.	Performance Checks	5-3
5-11.	Frequency Accuracy Check	5-3
5-12.	Q Range Check	5-3
5-13.	Δ Q Range Check	5-4
5-14.	Capacitance Accuracy Check	5-4
5-15.	Q Limit Operation Check	5-5
5-16.	Adjustment and Calibration Procedures	5-8
5-18.	Power Supply Adjustment	5-8
5-19.	Oscillator Level Adjustment	5-8
5-20.	Oscillator Frequency Adjustment	5-8
5-21.	Q Voltmeter Adjustment	5-9
5-22.	Q Analog Output Adjustment	5-10
5-23.	Frequency Response Adjustment	5-11
5-24.	Q Limit Selector Adjustment	5-11
5-25.	Option 001 Maintenance Instructions	5-12
5-27.	Option 001 Performance Checks	5-12
5-29.	Option 001 Calibration and Adjustment Procedures ..	5-13
5-31.	Dial Re-stringing Instructions	5-14
5-34.	Frequency Dial	5-14
5-35.	L/C Dial	5-14
5-36.	Δ C Dial	5-14
5-37.	Troubleshooting Guides	5-18
5-39.	High Frequency Line Noise	5-18
5-40.	Operating in a Strong Electromagnetic Field	5-18
5-41.	Operating in High Humidity Environment	5-18

Section	Title	Page
5-42.	Elementary Troubleshooting Guide	5-18
5-43.	Meter Zeroing Troubles	5-18
5-44.	Incorrect Q Meter Indication	5-18
5-45.	Low Q Indication in High Frequency Measurements	5-19
5-46.	Faulty Q Limit Operation	5-19
VI	REPLACEABLE PARTS	6-1
6-1.	Introduction	6-1
6-6.	Ordering Information	6-1
VII	MANUAL CHANGES AND OPTIONS	7-1
7-1.	Options	7-1
7-3.	Special Instruments	7-1
7-5.	Manual Changes	7-1
7-7.	Later Instruments	7-1
7-8.	Earlier Instruments	7-1
7-9.	Option 001 Instruments	7-1
VIII	CIRCUIT DIAGRAMS	8-1
8-1.	Introduction	8-1
8-4.	General Notes	8-1
APPENDIX	OPTION 001	A-1
I	Replaceable Parts	A-1
II	Manual Changes	A-1
III	Circuit Diagrams	A-2

LIST OF TABLES

Number	Title	Page
1-1.	Specifications	1-2
1-2.	Accessories - Typical Values	1-3
2-1.	AC Line Fuse	2-1
3-1.	Methods of Connecting Unknown	3-10
3-2.	16451A (4342A-K01) Typical Characteristics	3-21
3-3.	Formulas for Calculating Q and Impedance Parameters from Parallel and Series Measurements	3-27
3-4.	Formulas Relating Series and Parallel Components	3-27
5-1.	Recommended Test Equipment	5-0
5-2.	Q Correlation Factors	5-1
5-3.	Frequency Accuracy Check	5-2
5-4.	Q Range Check	5-3
5-5.	Capacitance Accuracy Check	5-5
5-6.	Adjustable Components	5-7
5-7.	Frequency Adjustment	5-9
5-8.	Frequency Accuracy Check (Option 001)	5-12
5-9.	Frequency Adjustment (Option 001)	5-13
6-1.	List of Reference Designators and Abbreviations	6-1
6-2.	Reference Designation Index	6-3
7-1.	Backdating Changes	7-1
A-1.	Reference Designation Index for Option 001 (A1A1 Ass'y) ..	A-3
A-2.	Reference Designation Index for Option 001 (A5 Ass'y)	A-5

LIST OF ILLUSTRATIONS

Number	Title	Page
1-1.	Model 4342A Q Meter	1-1
3-1.	Front Panel Controls	3-2
3-2.	Rear Panel Controls and Connectors	3-4
3-3.	Measurement Terminal Circuit	3-5
3-4.	Inductance Measurement Ranges vs. Frequency (direct method)	3-6
3-5.	Ranges of Measurable Resistance	3-7
3-6.	Zeroing Procedure	3-8
3-7.	Distributed Capacitance in Direct Connection	3-11
3-8.	Distributed Capacitance Circuit Model	3-13
3-9.	Typical Variation of Effective Q and Inductance with Frequency	3-14
3-10.	Correction Chart for Distributed Capacitance	3-14
3-11.	Residual Parameters	3-17
4-1.	Series Resonant Circuit	4-0
4-2.	Model 4342A Simplified Block Diagram	4-0
4-3.	Constant Voltage Injection System	4-2
5-1.	Q Range Check	5-2
5-2.	4Q Range Check	5-3
5-3.	Capacitance Accuracy Check	5-4
5-4.	Model 4342A Adjustment Locations	5-6
5-5.	Model 4342A Assembly Locations	5-6
5-6.	Voltmeter Adjustment	5-10
5-7.	Frequency Response Adjustment	5-11
5-8.	Frequency Dial Restringing	5-15
5-9.	Main C Dial Restringing	5-16
5-10.	4C Dial Restringing	5-17
5-11.	Tuning Capacitor Disassembly (top view)	5-19
5-12.	Troubleshooting, Oscillator Section	5-21
5-13.	Troubleshooting, Voltmeter Section	5-19
6-1.	Exploded View of Oscillator Ass'y	6-22
6-2.	Exploded View of Tuning Capacitor Ass'y	6-24
6-3.	Exploded View of Q Range Attenuator Ass'y	6-26
6-4.	Exploded View of Frequency Multiplier, Over Limit Indicator, and Frequency Scale Indicator	6-27
6-5.	Exploded View of Main and Vernier Capacitor Dial Ass'y	6-28
6-6.	Exploded View of Oscillator Lever Ass'y	6-29
6-7.	Exploded View of Rear Panel	6-30
6-8.	Exploded View of Handle Section	6-32
7-1.	A7 04342-7707	7-2
7-2.	A11 04342-7711	7-2
7-3.	Partial Schematic of Power Supply	7-5
8-1.	Schematic Diagram Notes	8-2
8-2.	Function Overall Block Diagram	8-3
8-3.	Oscillator Ass'y A1, Q Range Attenuator Ass'y A3, Power Supply & ACL Amplifier Ass'y A8, Frequency Multiplier & Over Limit Indicator Ass'y A10 ..	8-5

Number	Title	Page
8-4.	Tuning Capacitor Ass'y A2, QRange Attenuator Ass'y A3, Impedance Converter Ass'y A4, Meter Scale Indicator Ass'y A11	8-7
8-5.	Q Range Attenuator Ass'y A3, Impedance Converter, RF Amplifier & Detector Ass'y A5, DC Amplifier Ass'y A6, Meter Scale Indicator Ass'y A11	8-9
8-6.	Q Limit Selector Ass'y A7	8-11
8-7.	Power Supply & ALC Amplifier Ass'y A8	8-13
A-1	Oscillator Ass'y A1 (Option 001)	A-7
A-2.	Impedance Converter, RF Amplifier & Detector Ass'y A5 (Option 001)	A-9

SECTION I GENERAL INFORMATION

1-1. INTRODUCTION.

1-2. The HP Model 4342A Q Meter is designed to meet the requirements for making easy and accurate quality factor measurements in the laboratory, on the production line, or in QA incoming inspection areas. The direct reading, expanded scale of the 4342A permits measurement of Q from 5 to 1000 and the reading of very small changes in Q resulting from variation in test parameters. The long frequency dial scale and the pushbutton range selector continuously cover the frequency range of 22kHz to 70MHz (in seven - 1/3 decade steps) and permit setting the frequency to an accuracy of 1.5% with 1% resolution.

The calibrated long-scale capacitance dials permit reading the capacitance of the tuning capacitor at an accuracy of 1% and provides the capability for varying the capacitance with 0.1pF resolution on the vernier scale. Inductance of sample can be read directly from the inductance scale adjacent to the capacitance scale at seven

specific frequencies by setting the frequency dial to the "L" point on each frequency range.

Flat oscillator output, automatically level-controlled over the entire frequency ranges, is a feature of the 4342A. This advantage obviates the necessity for frequent oscillator level adjustments to maintain the output level constant or the use of a specially matched fragile thermocouple level meter.

The high reliability of the instrument and ease of operation are the direct results of these measurement advancements in the 4342A.

For determining the resistance, reactance, or quality factor of capacitance and inductance samples in the high frequency region, the 4342A is a most versatile measuring instrument. The 4342A can measure the dissipation factor and dielectric constant of insulating materials, coefficient of coupling, mutual inductance, and the frequency characteristics of transformers. Accessories which extend the measurement capabilities, designed for

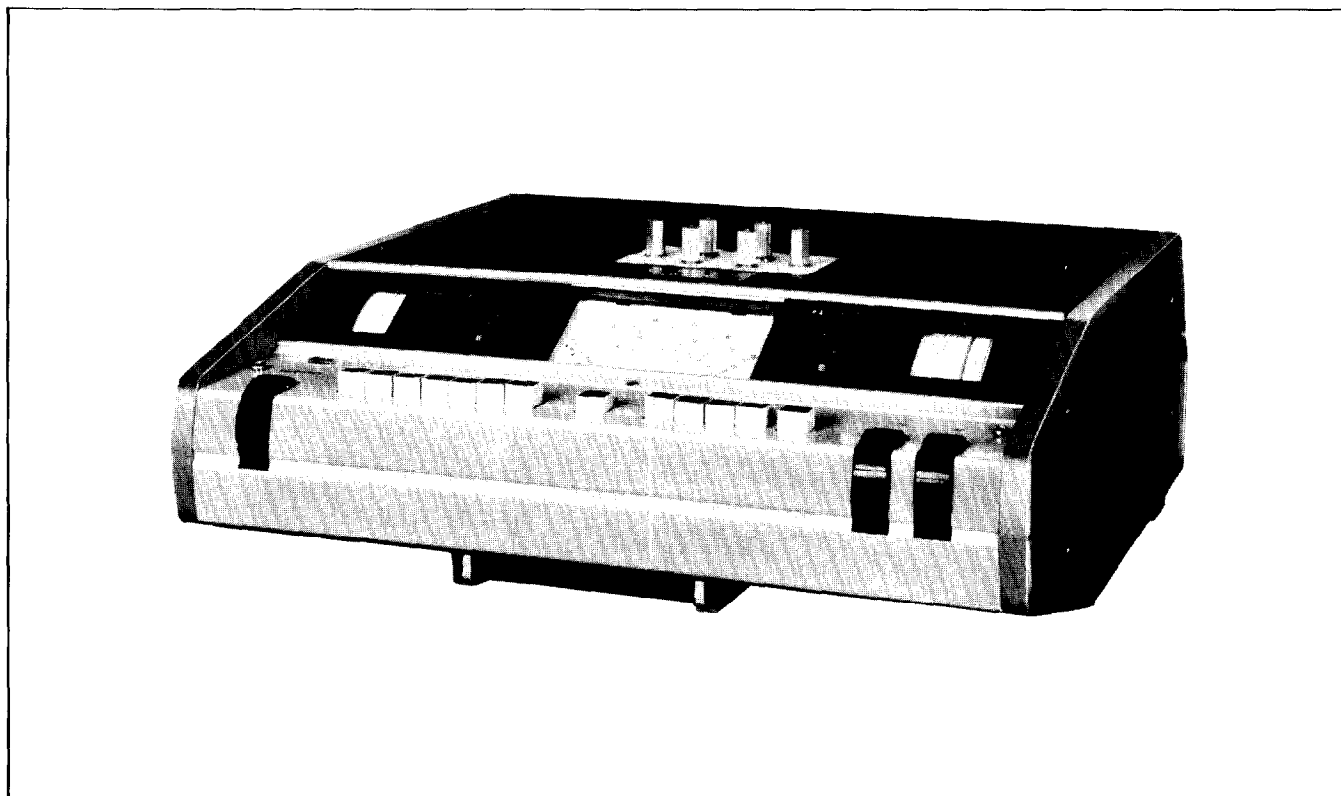

Figure 1-1. Model 4342A Q Meter.

Section I
Paragraphs 1-3 to 1-12

user convenience, have broad applications in testing components and electronic materials, in physical and chemical research, and in related scientific fields.

Pushbutton operation of frequency range and $Q/\Delta Q$ range selection provides for straightforward measurement. Automatic indication of meter scales, frequency dials, and frequency multipliers are used, adding to the simplicity and reading speed.

1-3. How The 4342A Measures.

1-4. The Q Meter is basically composed of a stable, variable oscillator, a tuning circuit for taking resonance with an unknown sample, and a high input impedance RF voltmeter connected across the variable capacitor which is a section of the tuning circuit.

To measure the quality factor of a sample, a stable oscillator signal is injected into the series tuning circuit composed of the variable capacitor and the unknown (inductor). At the tuned frequency, the RF voltmeter (called Q voltmeter) indicates a peak value in the signal level increase (resonance) and is proportional to the quality factor of the sample measured. By injecting an oscillator signal with a low output impedance and by measuring the signal level of the series resonant circuit with a high impedance voltmeter, the quality factor of the unknown sample can be accurately determined at the resonant frequency. Additionally, various parameters of the sample can be measured (directly and indirectly) as factors of the resonant frequency and the tuning capacity which can be read from their respective dial scales.

1-5. For accurate measurements, the 4342A employs a unique constant voltage injection system and a low output impedance injection transformer. The oscillator signal is automatically leveled by an ALC loop to provide the constant injection voltage required by the Q range in use. This obviates the need of an oscillator level control or the fragile thermocouple level meter (as used in traditional Q Meters). The unique injection transformer along with the high quality low loss tuning capacitor contribute minimal additional loss to the measurement circuit (resonant circuit) and greatly improve the Q accuracy in high Q measurements.

1-6. High stability of the Q voltmeter virtually eliminates the need for Q-zero adjustments in routine measurements. Troublesome zero settings prior to each adjustment are thus eliminated, ensuring simple and rapid operation. Accurate determination of Q changes

in delta-Q measurements can be obtained in all Q ranges by using the expanded resolution (X10) capability.

1-7. The unique Q Limit selector is especially useful in Go/No-Go checking on the production line. The high response speed of the Go/No-Go indicator (compared to using a meter pointer deflection method) permits faster Go/No-Go testing. For even easier testing, external indicating devices may be remotely controlled by the Go/No-Go output signal (on the rear panel).

1-8. INSTRUMENTS COVERED BY MANUAL.

1-9. Hewlett-Packard uses a two-section nine character serial number which is marked on the serial number plate (Figure 1-2) attached to the instrument rear panel. The first four digits and the letter are the serial prefix and the last five digits are the suffix. The letter placed between the two sections identifies country where instrument was manufactured. The prefix is the same for all identical instruments; it changes only when a change is made to the instrument. The suffix, however, is assigned sequentially and is different for each instrument. The contents of this manual apply to instruments with the serial number prefix(es) listed under SERIAL NUMBERS on the title page.

1-10. An instrument manufactured after the printing of this manual may have a serial number prefix that is not listed on the title page. This unlisted serial number prefix indicates that the instrument is different from those described in this manual. The manual for this new instrument may be accompanied by a yellow Manual Changes supplement or have a different manual part number. This supplement contains "change information" that explains how to adapt the manual to the newer instrument.

1-11. In addition to change information, the supplement may contain information for correcting errors (called Errata) in the manual. To keep this manual as current and accurate as possible, Hewlett-Packard recommends that you periodically request the latest Manual Changes supplement. The supplement for this manual is identified with this manual's title page. Complimentary copies of the supplement are available from Hewlett-Packard. If the serial prefix or number of an instrument is lower than that on title page of this manual, see Section VII Manual Changes.

1-12. For information concerning a serial number prefix that is not listed on the title page or in the Manual Changes supplement, contact your nearest Hewlett-Packard office.

1-13. SPECIFICATIONS.

1-14. Complete specifications of the Model 4342A Q Meter are given in Table 1-1. These specifications are the performance standards or limits against which the instrument is tested. The test procedures for testing the instrument to determine if it meets its specifications are covered in Section V Maintenance Paragraph 5-9 Performance Checks. When the 4342A Q Meter is shipped from the factory, it meets the specifications listed in Table 1-1.

1-15. ACCESSORIES SUPPLIED.

1-16. Fuses (HP Part No. 2110-0339 and 2110-0044), the Operating and Service Manual, and a power cord are furnished with the 4342A. One of four types of power cords (HP Part No. 8120-1703, -0696, -1692 or -1521) is furnished depending on the instrument destination. All accessories supplied are packed in the instrument carton.

1-17. ACCESSORIES AVAILABLE.

1-18. Accessories are specially designed devices which extend or enhance the measurement capabilities of the 4342A. The following accessories are available for use with the 4342A Q Meter:

16470 Series Supplemental Inductors:

A range of 20 inductors (model numbers 16471A to 16490A), which can be supplied separately or as a set, are available for use with the 4342A Q Meter. These inductors are useful as reference devices when measuring the RF characteristics of capacitors, resistors, or insulating materials. For 4342A option 001 instruments, the Model 16465A Inductor is additionally available. These inductors have three terminals including a guard terminal for stabilization of measurements.

16462A Auxiliary Capacitor:

The 16462A Auxiliary Capacitor is designed to extend the Q and L measurement capabilities of the 4342A. It is especially useful when measuring small inductors at low frequencies.

16014A Series Loss Test Adapter:

The 16014A Series Loss Test Adapter is a special terminal adapter designed for measuring low impedance components, low-value inductors and resistors, and also high value capacitors. The adapter adds convenience in connecting components in series with the test circuit of the 4342A Q Meter. It consists of a teflon printed-circuit base on which are mounted binding posts to accept the supplemental inductors, and a pair of low-inductance series terminals for the unknown.

16451A Dielectric Test Adapter (4342A-K01):

The 16451A Dielectric Test Adapter is a test fixture for measuring the dielectric constant or dielectric loss angle ($\tan \delta$) of insulating materials. The 16451A has a pair of precision variable electrodes (one side is fixed) which hold the sample and which operate similar to a micrometer to permit direct reading of electrode spacing. This test adapter is directly attached to 4342A measurement terminals.

Typical performance, characteristics, and additional information regarding these accessories are given in Table 1-2.

1-19. OPTIONS.

1-20. An option is a standard modification performed in the instrument to meet a special requirement desired by a user. When an instrument model is ordered with an option number, the corresponding optional parts are installed in/or packaged with instrument at the factory. An Option for obtaining a lower measurement frequency range is available for installation in the 4342A.

1-21. Option 001.

1-22. The 4342A Option 001 covers a lower frequency range, 10kHz to 32MHz, instead of the standard frequency range of 20kHz to 70MHz. All specifications that apply to Option 001 instruments are given in Table 1-1.

Table 1-1. Specifications (Sheet 1 of 2).

FREQUENCY CHARACTERISTICS

Measurement Frequency Range:
22kHz to 70MHz in 7 bands (22 to 70kHz, 70 to 220kHz, 220 to 700kHz, 700 to 2200kHz, 2.2 to 7MHz, 7 to 22MHz, and 22 to 70MHz).

Frequency Dial Accuracy:
±1.5% at 22kHz to 22MHz,
±2% at 22MHz to 70MHz,
±1% at "L" point on frequency dial.

Frequency Dial Resolution:
Approximately ±1%.

Q MEASUREMENT CHARACTERISTICS

Q Range:
5 to 1000 in 4 ranges (5 to 30, 20 to 100, 50 to 300, and 200 to 1000).

Q Tolerance: % of indicated value
(at 25°C)

Q	Fre- quency	
	22kHz - 30MHz	30MHz - 70MHz
5 - 300	±7%	±10%
300 - 600	±10%	±15%
600 - 1000	±15%	±20%

Q Resolution:
Upper scale: 1 from 20 to 100,
Lower scale: 0.5 from 5 to 30.

ΔQ Range:
0 to 100 in 4 ranges, 0 to 3, 0 to 10, 0 to 30, 0 to 100.

ΔQ Tolerance:
±10% of full scale.

ΔQ Resolution:
Upper scale: 0.1 from 0 to 10,
Lower scale: 0.05 from 0 to 3.

INDUCTANCE MEASUREMENT CHARACTERISTICS

L Range:
0.09μH to 1.2H, direct reading for seven specific frequencies as marked at the frequency dial "L" scale point and selected by the frequency range switches.

L Accuracy:
±3% after compensation for residual inductance (approx. 10nH).

TUNING CAPACITOR CHARACTERISTICS

Capacitance Range:
Main dial capacitor: 25 to 470pF
Vernier dial capacitor: -5 to +5pF

Capacitance Dial Accuracy:
Main dial: ±1% or 1pF whichever is greater.
Vernier dial: ±0.1pF.

Capacitance Resolution:
Main dial: 1pF from 25 to 30pF,
2pF from 30 to 200pF,
5pF from 200 to 470pF.
Vernier dial: 0.1pF.

Table 1-1. Specifications (Sheet 2 of 2).

REAR PANEL OUTPUTS

- Frequency Monitor:
170mVrms min. into 50Ω.
- Q Analog Output:
1V ±50mV dc at full scale, proportional to meter deflection, output impedance approx. 1kΩ.
- Over Limit Signal Output:
Single pole relay contact output, one side grounded, relay contact capacity 0.5A/15VA.
- Over Limit Display Time:
Switch-selectable, 1sec. or continuous.

GENERAL

- Operating Temperature Range:
0°C to 50°C.
- Warm-up Time: 30 minutes.
- Power: 115 or 230V ±10%, 48 - 440Hz, approx. 25VA.
- Weight: Approx. 31 lbs (14kg).
- Accessories Furnished:
Power Cord
- Accessories Available:
16471A through 16490A, and 16465A Supplemental Inductors.
16462A Auxiliary Capacitor.
16014A Series Loss Test Adapter.
16451A Dielectric Test Adapter.
- Extender Board 15pin
(Part No. 5060-4940).
- Extender Board 6pin
(Part No. 5060-0651).

OPTION 001:

This option covers a frequency range of 10kHz to 32MHz. Specifications are identical with those of the standard model except as noted below.

Oscillator Frequency Range:
10kHz to 32MHz in 7 bands (10 to 32kHz, 32 to 100kHz, 100 to 320kHz, 320 to 1000kHz, 1 to 3.2MHz, 3.2 to 10MHz, and 10 to 32MHz).

Frequency Accuracy:
±1.5% at 10kHz to 10MHz.
±2% at 10MHz to 32MHz.
±1% at "L" point on frequency dial.

Q Tolerance: % of indicated value (at 25°C)

Q		
5 - 300	300 - 600	600 - 1000
±7%	±10%	±15%

DIMENSIONS:

NOTE:
DIMENSION IN INCHES AND (MILLIMETERS).

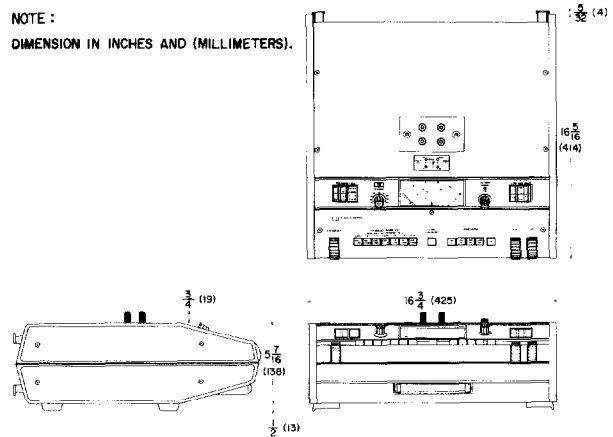

Table 1-2. Accessories - Typical Values.

16471A - 16490A, 16465A Supplemental Inductors						
Model	Inductance	Approx. resonant frequency for tuning capacitance of			Q Limit	Capacitance (pF)
		400pF	100pF	50pF		
16471A	130 mH	22	40	62 kHz	below 300(30 kHz)*	8
16472A	52 mH	35	70	100 kHz	below 300(50 kHz)*	8
16473A	25 mH	50	100	140 kHz	below 300(70 kHz)*	8
16474A	10 mH	80	160	220 kHz	below 300(100 kHz)*	8
16475A	5.2mH	110	220	300 kHz	below 300(150 kHz)*	8
16476A	2.8mH	150	300	420 kHz	below 300(200 kHz)*	8
16477A	1 mH	250	500	700 kHz	below 300(300 kHz)*	8
16478A	520 μH	350	700	1000 kHz	below 300(500 kHz)*	8
16479A	250 μH	500	1000	1400 kHz	below 300(1MHz)*	7
16480A	100 μH	800	1600	2200 kHz	below 300(1MHz)*	7
16481A	56 μH	** 1	2.2	3.1MHz	below 300(1MHz)*	7
16482A	28 μH	1.5	3	4.2MHz	below 300(1.5MHz)*	7
16483A	10 μH	2.5	5	7 MHz	below 300(2.5MHz)*	6
16484A	5.2μH	3.5	7	10 MHz	below 300(10MHz)*	6
16485A	2.5μH	5	10	14 MHz	below 300(15MHz)*	6
16486A	1 μH	8	16	22 MHz	below 300(20MHz)*	6
		100pF		35pF		
16487A	0.52 μH	22MHz		35MHz	below 300(35MHz)*	6
16488A	0.28 μH	30MHz		50MHz	below 300(50MHz)*	4
16489A	0.1 μH	50MHz		70MHz	below 300(70MHz)*	3
16490A	0.07 μH	60MHz		100MHz	below 300(70MHz)*	2
		400pF	100pF	50pF		
***16465A	630 mH	10	20	28 kHz	below 300(12 kHz)*	9

* The frequency in parentheses indicates frequency at which maximum Q factor is obtained (for the respective inductor).
 ** Approx. resonant frequency for tuning capacitance of 450pF.
 *** For 4342A Option 001 use only.

16462A Auxiliary Capacitor

Capacitance Range: 300pF to 2700pF in steps of 300pF. 10 ranges including OFF position.

Capacitance Accuracy: ±1% on all ranges.

Q: 5000 at 20kHz on all ranges.

Residual inductance: approx. 0.1μH.

Residual capacitance at OFF position: approx. 23pF.

Measurable Capacitance Range: 450pF to 0.225μF.

Measurable Resistance Range: 10mΩ to 80Ω at 10MHz, 4Ω to 8kΩ at 10kHz.

Stray Capacitance Between Unknown Terminals: approx. 3pF.

Insulation Resistance between Unknown Terminals: approx. 10MΩ at 1MHz.

Residual Inductance: approx. 30nH

16014A Series Loss Test Adapter

Useable Frequency Range: 10kHz to 10MHz.

16451A Dielectric Test Adapter

(refer to Page 3-21 Table 3-2).

SECTION II INSTALLATION

2-1. INTRODUCTION

2-2. This section contains information for unpacking, inspection, repacking, storage, and installation of the Model 4342A.

2-3. INITIAL INSPECTION

2-4. MECHANICAL CHECK

2-5. If damage to the shipping carton is evident, ask that the carrier's agent be present when the instrument is unpacked. Inspect the instrument for mechanical damage. Also check the cushioning material for signs of severe stress.

2-6. PERFORMANCE CHECKS

2-7. The electrical performance of the Model 4342A should be verified upon receipt. Performance checks suitable for incoming inspection are given in Section V, Maintenance.

2-8. DAMAGE CLAIMS

2-9. If the instrument is mechanically damaged in transit, notify the carrier and the nearest Hewlett-Packard field office immediately. A list of field offices is on the back of this manual. Retain the shipping carton and padding material for the carrier's inspection. The field office will arrange for replacement or repair of your instrument without waiting for claim settlements against the carrier.

2-10. Before shipment this instrument was inspected and found free of mechanical and electrical defects. If there is any deficiency, or if electrical performance is not within specifications, notify your nearest Hewlett-Packard Sales and Service Office.

2-11. STORAGE AND SHIPMENT

2-12. PACKAGING. To protect valuable electronic equipment during storage or shipment always use the best packaging methods available. Your Hewlett-Packard field office can provide packing material such as that used for original factory packaging. Contract packaging companies in many cities can provide dependable custom packaging on short notice. Here are a few recommended packaging methods:

- a. **RUBBERIZED HAIR.** Cover painted surfaces of instrument with protective wrapping paper. Pack instrument securely in strong corrugated container (350 lb/sq in. bursting test) with 2-inch rubberized hair pads placed along all surfaces of the instrument. Insert fillers between pads and container to ensure a snug fit.
- b. **EXCELSIOR.** Cover painted surfaces of instrument with protective wrapping paper. Pack instrument in strong corrugated container (350 lb/

sq in. bursting test) with a layer of excelsior about 6 inches thick packed firmly against all surfaces of the instrument.

2-13. ENVIRONMENT. Conditions during storage and shipment should normally be limited as follows:

- a. Maximum altitude, 20,000 feet
- b. Minimum temperature, -40° F (-40° C)
- c. Maximum temperature, 167° F (75° C)

2-14. POWER CONNECTION

2-15. LINE VOLTAGE. The Model 4342A operates from either 115 or 230 volt ($\pm 10\%$) ac line voltage and Line frequency from 50 to 400Hz. A slide switch on the rear panel permits quick conversion for operating from either voltage. Insert a narrow-blade screwdriver in the switch slot and slide the switch to the right for 115-volt operation ("115" marking exposed) or to the left for 230-volt operation ("230" marking exposed). The Model 4342A is supplied with 115-volt fuse; for 230-volt operation, be sure to replace this fuse with that listed in Table 2-1.

Table 2-1. AC Line Fuse

Conversion	115-volt	230-volt
Slide Switch	Right ("115")	Left ("230")
AC Line Fuse	0.6 amperes Slow-Blow 2110-0339	0.3 amperes Slow-Blow 2110-0044

CAUTION

To avoid damage to the instrument, before connecting the power cable, set the 115/230-volt switch for the line voltage to be used.

2-16. POWER CABLE. To protect operating personnel, the National Electrical Manufacturers Association (NEMA) recommends that instrument panels and cabinets be grounded. Accordingly, the Model 4342A is equipped with a detachable three-conductor power cable which, when plugged into an appropriate receptacle, grounds panel and cabinet. The offset pin of the three-prong connector is the ground pin. Proceed as follows for power cable installation.

- a. Connect flat plug (3-terminal connector) to LINE jack at rear of instrument.
- b. Connect plug (2-blade with round grounding pin) to 3-wire (grounded) power outlet. Exposed

portions of instrument are grounded through the round pin on the plug for safety; when only 2-blade outlet is available, use connector adapter (HP Part No. 1251-0048). Then connect short wire from slide of adapter to ground to preserve the protection feature.

SECTION III OPERATION

3-1. INTRODUCTION.

3-2. The 4342A Q Meter can measure the quality factor of inductors from 5 to 1000 and, in addition, capacitance, inductance and resistance, and the dielectric constant of insulating materials over the frequency range of 22kHz to 70MHz. This section provides the instructions and information necessary for operating the 4342A Q Meter.

Fundamental operating procedures and general techniques for measuring various parameter values of the unknown directly and indirectly by using accessories appropriate to the characteristics of the unknown are also outlined in this section.

3-3. PANEL CONTROLS, CONNECTORS AND INDICATORS.

3-4. Control panel, top terminal deck, and rear panel features of the 4342A are described in Figures 3-1 and 3-2. The numbers in the illustrations are keyed to the descriptive items for each figure. Other detailed information about the functions of the panel controls and connectors is provided in paragraphs 3-8 through 3-11.

3-5. Q MEASUREMENT-GENERAL.

3-6. To complete the measuring circuit, the Model 4342A requires the connection of an inductor to the measurement COIL terminals. This circuit is then used to establish a resonance, either by setting the frequency controls to a predetermined frequency and varying the tuning capacitor, or by presetting the tuning capacitor to a desired value and adjusting the frequency controls. Resonance is indicated by maximum deflection of the panel Q meter. The Q value of the sample is proportional to Q meter deflection at the resonant frequency.

3-7. The "indicated Q" which is the Q meter reading at resonance is called the "circuit Q" because it includes all the additive losses inherent in the instrument including

those in the tuning capacitor, the Q voltmeter input resistance, output resistance of the oscillator signal injection circuit, and contact resistances of the measurement terminals. To avoid ambiguity, the Q meter reading or "circuit Q" is called "indicated Q" throughout the balance of this manual. The "effective Q", which is dependent only on the inherent loss of the sample and can be measured only by an ideal measuring circuit, is somewhat greater than the "indicated Q". However, the "indicated Q" can approximate the "effective Q", by reducing instrument losses as much as is possible. So, in most instances, these Q values can be deemed to be the same. The 4342A employs a Constant Voltage Injection System obviating the use of a thermocouple level meter (the resistance of thermocouple device would contribute additional losses to the measuring circuit) and the coupling resistor used in traditional Q meters. The low output impedance of the injection transformer, the improved operating performance of the Q voltmeter, and the precision tuning capacitor which has extremely low loss over a wide frequency range minimize the difference between the "indicated Q" and "effective Q".

3-8. GO/NO-GO FUNCTION.

3-9. The 4342A Go/No-Go function provides an annunciation when the measured Q value exceeds a reference value. Two annunciation outputs, the OVER LIMIT lamp display and a relay contact output (rear panel) are available. The OVER LIMIT indicator lamp lights and the relay is energized when the measured Q value is over the reference value set by the front panel Q LIMIT control. Annunciation time can be selected to occur at either 1 second intervals or to be continuous by the rear panel OVER LIMIT DISPLAY TIME switch. When the switch is set to its 1 sec position and the Q meter indication goes over the preset Q limit control value, the OVER LIMIT lamp lights once for 1 second. In the continuous mode, the lamp stays continuously lit during the entire time that the Q value meter deflection exceeds the preset value. Relay contact output follows in the same manner.

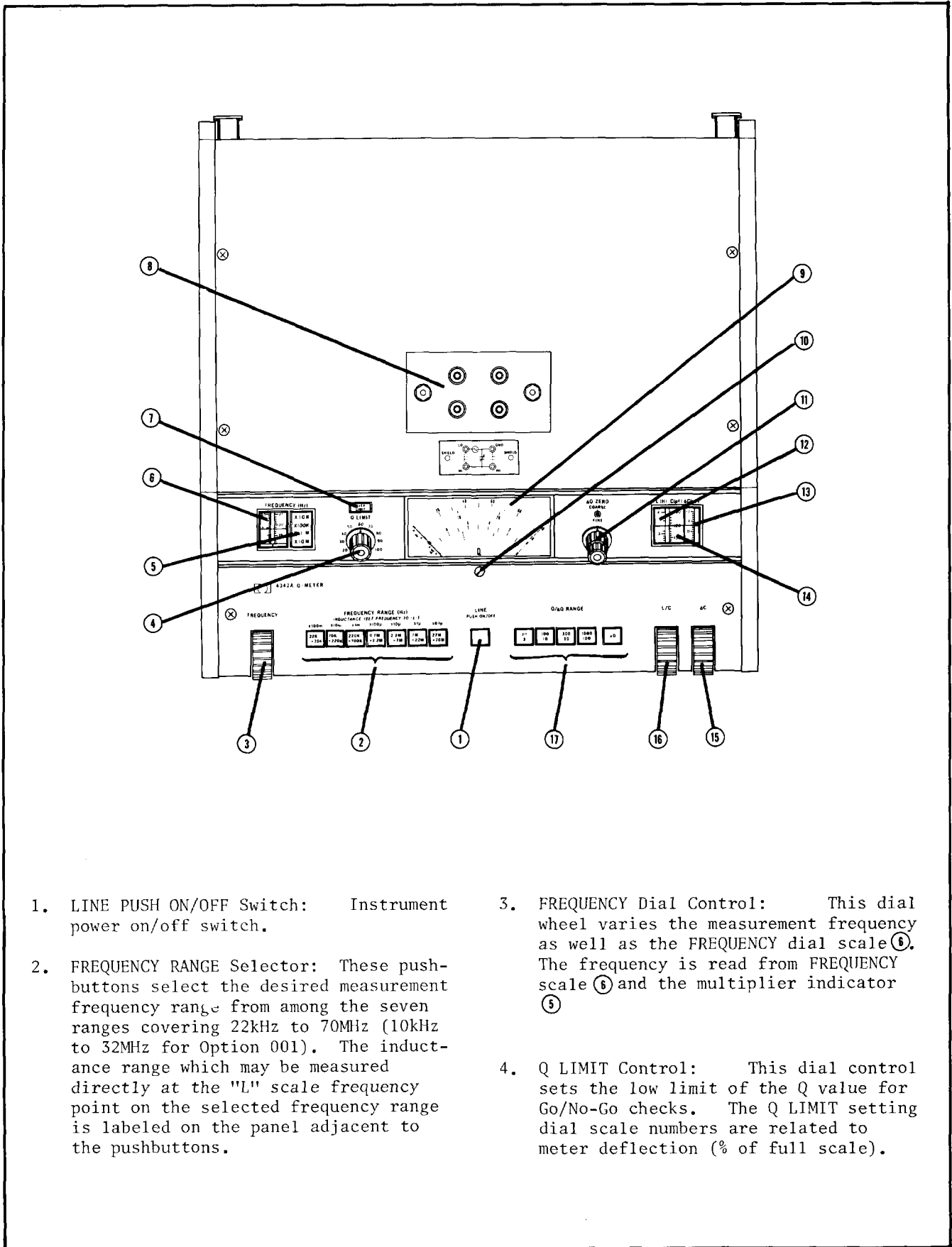

1. LINE PUSH ON/OFF Switch: Instrument power on/off switch.
2. FREQUENCY RANGE Selector: These push-buttons select the desired measurement frequency range from among the seven ranges covering 22kHz to 70MHz (10kHz to 32MHz for Option 001). The inductance range which may be measured directly at the "L" scale frequency point on the selected frequency range is labeled on the panel adjacent to the pushbuttons.
3. FREQUENCY Dial Control: This dial wheel varies the measurement frequency as well as the FREQUENCY dial scale (6). The frequency is read from FREQUENCY scale (6) and the multiplier indicator (5).
4. Q LIMIT Control: This dial control sets the low limit of the Q value for Go/No-Go checks. The Q LIMIT setting dial scale numbers are related to meter deflection (% of full scale).

Figure 3-1. Front Panel Controls (Sheet 1 of 2).

5. Frequency Multiplier Indicator: The Frequency multiplier indicators, adjacent to the frequency dial scale, light and correspond with the settings of the frequency range selector ② pushbuttons.
6. FREQUENCY Scale: The Frequency scale comprises two scales with ranges of 2.2 to 7.0 and 7 to 22 (1.0 to 3.2 and 3.2 to 10 for Option 001). One or the other of the scales is automatically illuminated depending on the FREQUENCY RANGE selector ② setting.
7. OVER LIMIT Display: The letters "OVER LIMIT" are displayed when the measured Q value exceeds the limit value set by the Q LIMIT control ④.
8. Measurement Terminals: These binding post terminals facilitate connection of the unknown and the various measurement aid accessories. A simplified terminal circuit schematic is provided by the top panel label.
9. Q Meter: At maximum meter pointer deflection, this meter indicates the Q value of the sample or of the measuring circuit as well as the optimum tuning point. The outer two scales (0 to 100 and 0 to 30) are the Q readings. The inner two reverse scales (10 to 0 and 3 to 0) provide ΔQ readings when making ΔQ measurements. Meter scale indicators at the left end of scale automatically light to indicate the appropriate scale (to read) on the selected Q/ ΔQ range.
10. Meter Pointer Adjustment Screw: This adjustment screw zero-sets the meter pointer so it is exactly over the zero calibration mark when the instrument is off.
11. ΔQ ZERO Controls: These coarse and fine controls adjust the meter indication for zero (reference) scale in ΔQ measurements. This function applies only to ΔQ measurements.
12. L Scale: This dial scale allows direct reading of inductance sample values at the "L" frequency. An "L" scale frequency point, common to and useable on all frequency ranges, is labeled with a blue letter on the FREQUENCY scale ⑥. The L scale indicates the inductance value of the unknown when resonated with the tuning capacitance at the "L" frequency.
13. ΔC Scale: This dial scale permits the reading of the capacitance of a vernier tuning capacitor from -5pF to +5pF in 0.1pF steps. The actual tuning capacitance is sum of the C Scale ⑭ and the ΔC Scale readings. A small change in the tuning capacitance adjustment point resulting from a variation in test parameters can be accurately read from the spread ΔC scale.
14. C Scale: This dial scale is for reading the capacitance of the main tuning capacitor which may be varied from 25pF to 470pF. A C scale reading is exact (calibrated) when the ΔC scale ⑬ is set to 0pF.
15. ΔC Dial Control: This dial wheel varies the vernier tuning capacitor and moves the ΔC Scale ⑬. The control employs a string drive mechanism which facilitates easy adjustment of vernier capacitor.
16. L/C Dial Control: This dial wheel varies the main tuning capacitor as well as moving the C scale ⑭ and L scale ⑫.
17. Q/ ΔQ RANGE Selector: These push-buttons select the desired Q range (either 30, 100, 300 or 1000 full scale). ΔQ button enables ΔQ measurement and expands Q resolution by ten times (3, 10, 30 or 100 full scale).

Figure 3-1. Front Panel Controls (Sheet 2 of 2).

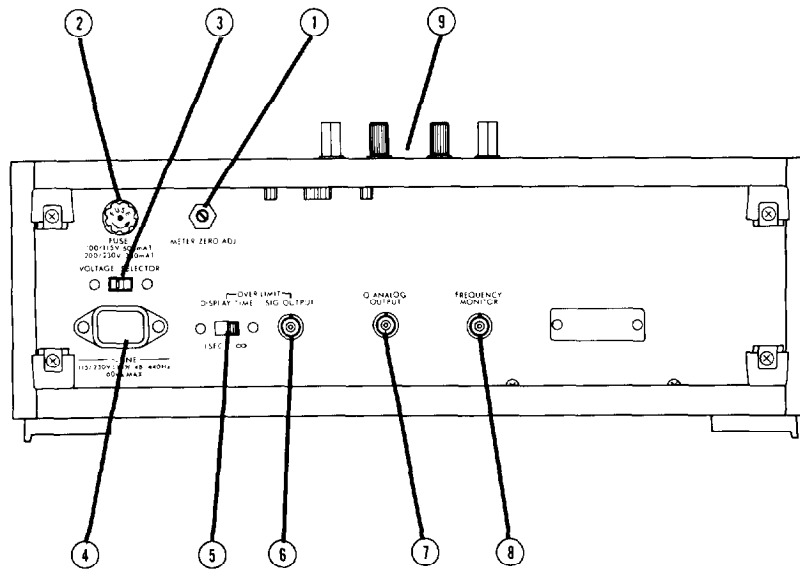

1. METER ZERO ADJ: This trimmer adjustment electrically zero-sets the meter pointer so that it is exactly over the zero calibration mark when the instrument is on.
2. FUSE: Instrument power fuse is installed in this fuse holder. Appropriate current rating for the fuse required is labeled on the rear panel.
3. VOLTAGE SELECTOR: This slide switch selects the appropriate ac operating power voltage (115V or 230V $\pm 10\%$). Selection of the ac voltage must be made before the instrument is connected to power line.
4. LINE Receptacle: Male ac power line receptacle with center ground pin for powering the instrument from a 115V or 230V, 48 - 440Hz line. Before connecting power cord (furnished), VOLTAGE SELECTOR ③ should be properly set.
5. OVER LIMIT DISPLAY TIME Switch: This slide switch sets "OVER LIMIT" annunciation time for Go/No-Go checks to either 1 second (1 sec) or to continuous (∞).
6. OVER LIMIT SIG. OUTPUT Connector: Relay contact output for Go/No-Go checks. Center and outer conductors of this BNC connector are internally short-circuited when measured Q value exceeds the limit value set by the Q LIMIT control.
7. Q ANALOG OUTPUT Connector: 0 to 1V analog output proportional to meter deflection. Output impedance is approximately $1k\Omega$.
8. FREQUENCY MONITOR Connector: This BNC connector provides a portion of internal oscillator output for monitoring oscillator frequency with external equipment (such as a frequency counter). Output level is 170mVrms min. and output impedance is 50Ω .
9. Measurement Terminals: These six binding post terminals, including the two shield terminals, provide the connection capabilities for attaching the unknown sample as well as supplemental inductors, auxiliary capacitors, and other devices and accessories used in making measurements.

Figure 3-2. Rear Panel Controls and Connectors.

3-10. MEASUREMENT TERMINALS.

3-11. Six binding post terminals, including two shield terminals, mounted on the instrument top deck, facilitate connection of unknown samples and accessories to the measuring circuit. Figure 3-3 illustrates the measurement terminals circuit configuration. Shield terminals 3 and 6, and binding post 4 are directly connected to instrument chassis (grounded). Binding posts 1 and 2 are the LO and HI COIL terminals, respectively, to which an inductor is connected to compose the circuit to be resonated. Inductors can be measured by connecting them to the COIL terminals (1 and 2) and by taking resonance with the tuning capacitor. The oscillator signal is injected into the measuring circuit between LO COIL terminal 1 and GND terminal 4. Binding posts 4 and 5 are CAPACITOR terminals which are used for doing parallel connection measurements (outlined in paragraph 3-19). Shield terminals 3 and 6 are used for connection to the shield terminal of an inductor or to the guard terminal of the device connected between HI COIL terminal 5 and GND terminal 4.

3-12. HOW TO CONNECT UNKNOWN.

3-13. There are three basic methods of connecting unknown sample to the measuring circuit of the Q Meter. The characteristics of the unknown, the parameter value to be measured, and the measurement frequency are the factors which guide the selection of an appropriate connection method. The fundamental operating procedures for each individual connection method are outlined in Table 3-1.

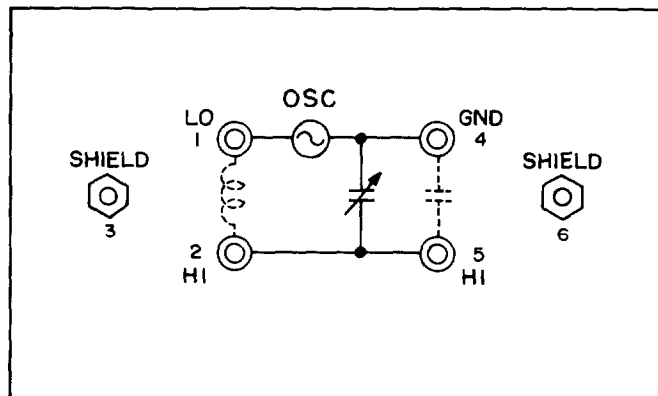

Figure 3-3. Measurement Terminal Circuit.

3-14. MEASUREMENT PARAMETERS AND CONNECTION METHODS.

3-15. The connection to the measuring circuit of the 4342A, when measuring quality factor, inductance, capacitance, resistance or dielectric constant, may be either a direct, parallel, or a series connection and depends upon the sample. As the sample values and measurement parameters are the guidelines for selecting an appropriate connection method, a discussion of the measurement capabilities unique to each connection method will help you to make straight-forward measurements. The measurement range limits of the individual connection methods and associated reasoning are outlined in the paragraphs which follow.

3-16. Direct Method Limitations.

3-17. When using the direct connection method in taking Q meter measurement parameters, only the quality factor, inductance, equivalent series resistance, and distributed capacitance of the inductor can be read from Q meter indications. In addition, the quality factor and the inductance measurement ranges covered by the direct connection method are dependent on sample inductance and measurement frequency. This is because the sample value and measuring frequency must satisfy the following mathematical relationship so as to resonate with the measuring circuit:

$$(2\pi f)^2 LC = 1 \dots\dots\dots (eq. 3-1)$$

- Where, f: Measurement frequency
- L: Inductance of sample
- C: Tuning capacitance (read from C dial scale; 25pF to 470pF)

For example, if the measurement frequency is 1MHz, the inductance range of a sample which can be measured directly by the 4342A is approximately 54μH to 1.2mH. And, for a given inductance, the measurement frequency range is indicated. For example, a 10μH inductor can be measured over a frequency range of approximately 2.3MHz to 11MHz. Additionally, the quality factor of sample must be below 1000 (upper range limit). Figure 3-4 shows the relationships between the measurement frequency and the inductance limits measurable with the 4342A alone (without using any supplemental equipment). In Figure 3-4, the shaded area denotes the applicable inductances and useable frequencies. The seven bold lines in the shaded area indicate the "L" frequencies and the ranges of inductance which can be read from the L/C dial L scale

at these particular L frequencies. The inductance at a measurement frequency other than the "L" frequency can be determined by substituting frequency and L/C dial (C scale) readings in equation 3-1.

3-18. Expansion of measurement ranges.

3-19. For higher or lower value inductances (above or below the shaded area in Figure 3-4), a parallel or series connection of the unknown to the measuring circuit enables the measurement to be made. To obtain the value of the desired parameter, these methods employ a comparison of the Q meter indications. The Q meter measuring circuit is first resonated with a reference inductor. Then the sample is connected in parallel or in series with the measuring circuit and the circuit again resonated. The sample value is calculated from the difference in Q meter indication measurements made before and after connecting the sample. In the equation from which the sample values are obtained, the values inherent in the reference inductor are subtracted from the measurement quantities. Consequently, the characteristics of the reference inductor do not (theoretically) affect measurement results.

In addition to their expanded measurement ranges, the parallel and series methods have some measurement capability advantages which do not appear when using direct methods.

A detailed description of these advantages is given in the discussion in paragraph 3-58.

3-20. Capacitance Measurement.

3-21. For capacitor samples, either a parallel or series connection method may be used when measuring either the capacitance or the Q value. The criteria for selecting the appropriate connection method concerns only the sample value and is irrespective of the measurement frequency. Capacitances higher than approximately 450pF (up to approximately 0.2μF) are normally measured by the series method and lower capacitances are easily measured by the parallel method. Generally, capacitors can be measured at the desired frequency by using an appropriate inductor as a measurement aid.

3-22. Resistance Measurement.

3-23. Resistance values are fundamentally calculated from measured Q values. Thus, the connection method selected depends upon the sample value and the measurement frequency. Figure 3-5 shows approximate limits for both parallel and series measurements. The upper shaded area indicates the combinations of frequency and measurable resistance values for parallel measurements. Similarly, the lower shaded area indicates the values for series measurements. For sample values between the upper and lower shaded areas, it is difficult

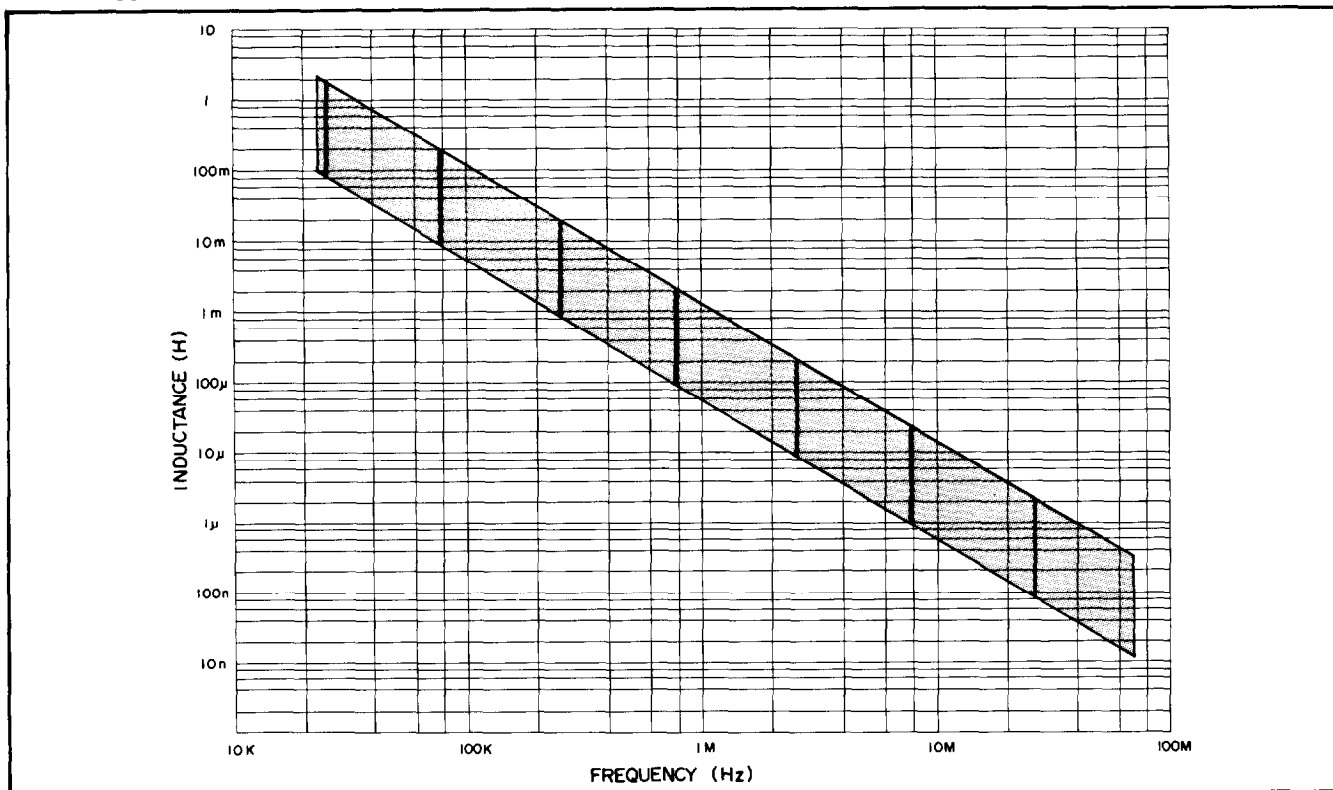

Figure 3-4. Inductance Measurement Ranges vs. Frequency (direct method).

to measure with either connection method. These limits are based on the use of a reference inductor having a Q value of 280. Parallel measurement low limits can be extended by using an external capacitor connected to the measurement CAPACITOR (HI and GND) terminals.

3-24. High Q Measurement.

3-25. Measurement of high quality factors up to 10000 can also be made by the parallel or series connection methods. These methods enable the measurement of low loss samples and are especially useful in the measurement of high Q capacitors. As inherent losses in the instrument will cause larger incremental measurement errors in higher Q measurements, these residual loss factors should be taken into consideration in the accuracies of measured values. In high Q measurements, the measured Q should be deemed to be only a rough approximation of the sample Q value. A detailed discussion on parallel and series connection measurement errors is provided in paragraph 3-60 and those which follow.

3-26. Supplemental Equipment Used in Parallel and Series Methods.

3-27. For use with the 4342A as reference inductors, the Model 16470A series supplemental inductors are available. The 16470A series inductors have various inductances (from 0.07 μ H to 630mH) and totally cover the frequency range of 10kHz to 70MHz when used with the 4342A as measurement aids. The reference inductor must be resonated alone (before connecting unknown) at the desired measurement frequency to take its inherent values for reference. And, of course, the useable frequency range of each individual supplemental inductor depends upon the inductance of the individual coil. This frequency range is indicated on a label attached to the case of each inductor. Detailed data and information on the supplemental inductors is tabulated in Table 1-2.

3-28. Inductor samples whose inductance is somewhat lower than the low limits of the measurement range of the 4342A may be measured by using an external high Q capacitor to extend the available tuning capacitance range. The external capacitor is connected between HI and GND measurement terminals; its capacitance, thereby, adds to the tuning capacitance. For this special purpose, the HP 16462A Auxiliary Capacitor is available. This capacitor module combines nine capacitors from 300pF to 2700pF (in 300pF steps) and, when used with the 4342A, allows measurement of low inductances to approximately 1/6.7 of the measurement low limit of the instrument.

3-29. Dielectric constant of an insulating material is calculated from the capacitance value of the sample held between a pair of electrodes whose dimensions are accurately known. Model 16451A Dielectric Test Adapter is the test fixture which is specially designed for measuring dielectric constant (ϵ) and dielectric loss angle ($\tan \delta$) and is directly attached to the 4342A measurement terminals. The 16451A has a pair of variable precision electrodes which can hold materials measuring up to a maximum of 10mm in thickness. The electrodes operate similar to a micrometer permitting direct reading of electrode spacing (0 to 10mm) with 0.02mm resolution. The diameter of the electrodes has been designed so as to simplify the associated calculations. Measurement time is thus greatly shortened.

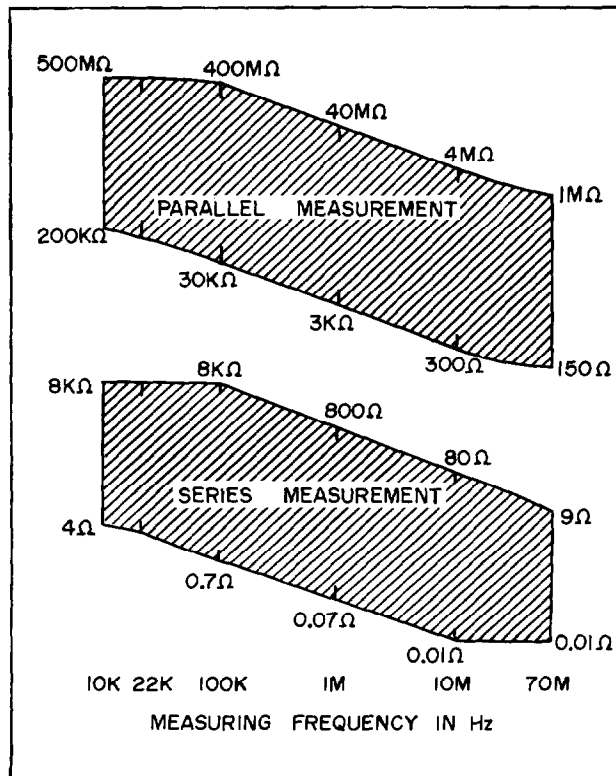

Figure 3-5. Ranges of Measurable Resistance.

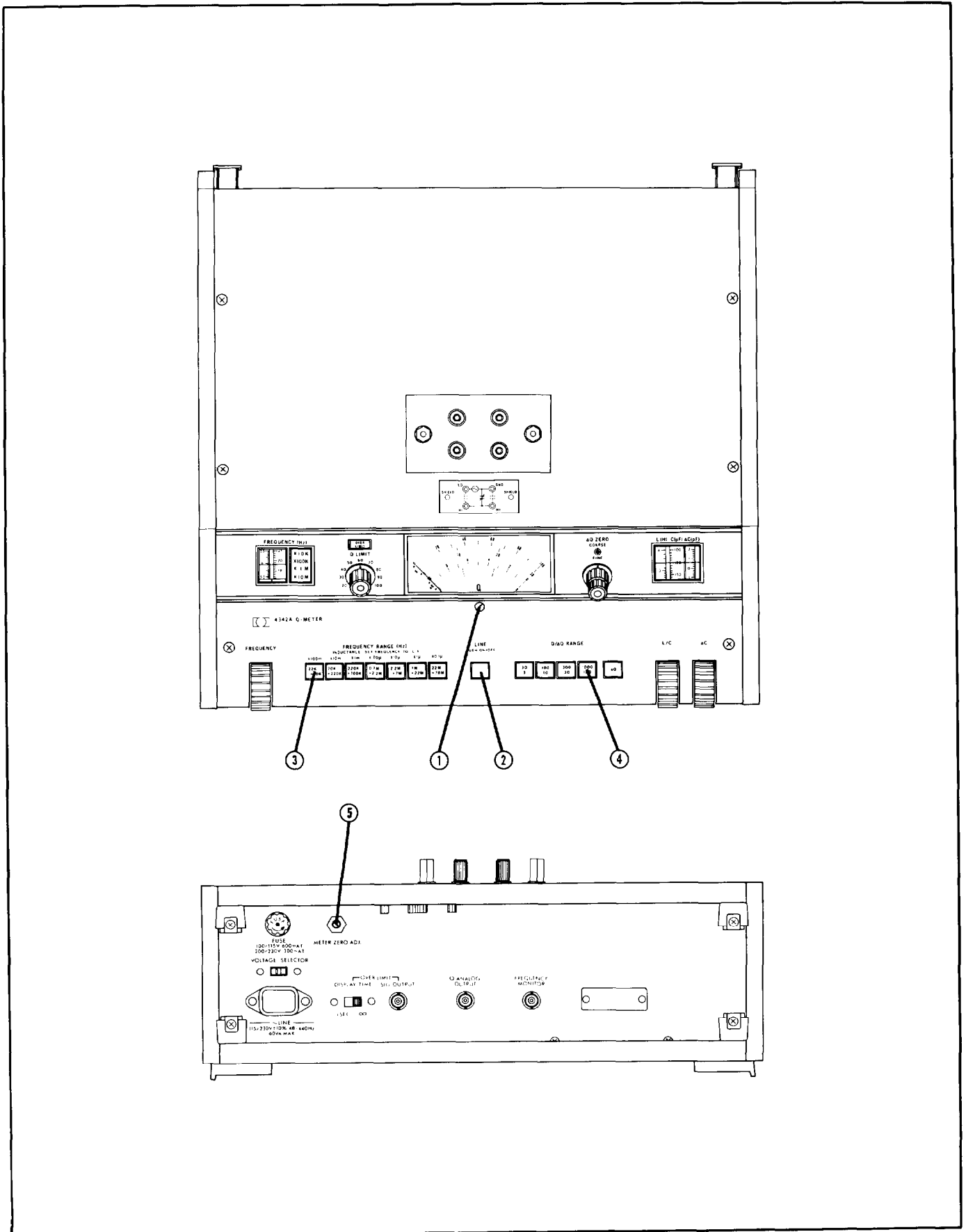

Figure 3-6. Zeroing Procedure (sheet 1 of 2).

Mechanical zero adjustment

The meter is properly zero-set when the pointer sets exactly over the zero calibration scale mark and the instrument is in its normal operating environment. To check the meter mechanical zero, turn the instrument off and allow 30 seconds to completely deenergize the instrument. To obtain maximum accuracy and mechanical stability, if the meter is not over zero, zero-set the meter as follows:

- a. Rotate meter pointer adjustment screw ① clockwise until meter is moving toward zero in an upscale direction.
- b. Continue rotating screw clockwise and stop when pointer is exactly at zero. If the pointer overshoots, continue rotating the adjustment screw clockwise to do steps a and b once again.
- c. When the pointer is exactly over zero, rotate adjustment screw slightly counterclockwise to relieve tension on pointer suspension. If pointer moves off zero, repeat steps a, b and c, but rotate less counterclockwise.

Electrical zero adjustment

The meter pointer should set exactly over the zero scale mark when instrument is turned on and nothing is connected to measurement terminals. Turn the instrument on and allow at least 15 minutes warm-up time to let the instrument reach a stable operating condition. If meter pointer is not over zero, zero-set the meter as follows:

- a. Set FREQUENCY RANGE selector ③ to 22k - 70k (10k - 32k for Option 001) and Q RANGE ④ to 1000.
- b. Adjust rear panel METER ZERO ADJ control ⑤ so that the meter pointer is exactly over zero.

Figure 3-6. Zeroing Procedure (sheet 2 of 2).

Table 3-1. Methods of Connecting Unknown.

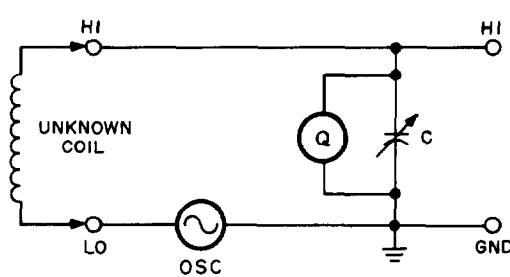
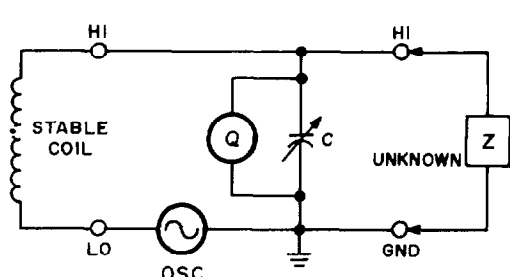
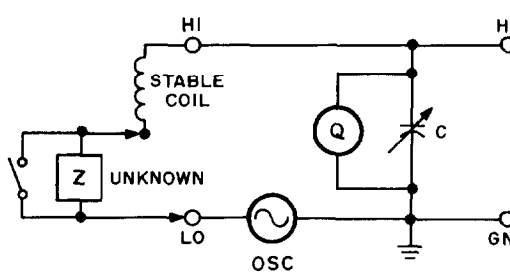
<p>Direct Connection.</p>  <p>(A)</p>	<p>Inductors can usually be measured by connecting them directly to the COIL terminals as shown in Figure A. The measuring circuit is resonated by adjusting either the L/C dial or the FREQUENCY dial controls. The quality factor (indicated Q) of the sample is read at maximum deflection of the Q Meter. Setting the FREQUENCY dial to the "L" scale point and taking resonance with the L/C dial control permits reading the inductance of the sample directly from the inductance scale (adjacent to the tuning capacitor scale). Otherwise the inductance can be calculated from the frequency and capacitance dial readings at the desired resonant frequency.</p>
<p>Parallel Connection.</p>  <p>(B)</p>	<p>The parallel connection is suitable for high impedance measurements. High inductances, high resistances, and small capacitances can be measured by connecting the samples to the CAPACITOR terminals as shown in Figure B. Before connecting a sample, the measuring circuit is resonated with a stable inductor (such as a 16470 series supplemental inductor) connected to the HI and LO COIL terminals to obtain a reference Q reading and a capacitance dial reading. The measuring circuit is again resonated with the sample connected to the CAPACITOR terminals by re-adjusting the L/C dial for maximum Q meter deflection. The parameter values of the sample are derived from the Q meter readings and the L/C dial readings obtained before and after connecting the unknown sample. The derivation of parameter values related to the unknown are detailed in paragraphs 3-64 through 3-72.</p>
<p>Series Connection.</p>  <p>(C)</p>	<p>The Series connection is suitable for low impedance measurements. Low inductances, low resistances and high capacitances can be measured by connecting the sample in series with a stable inductor as shown in Figure C. The 16014A Test Adapter is useful for making the series connection to the unknown sample. First, a shorting strap is attached to the unknown connection terminals in parallel with the sample and the measuring circuit resonated with the L/C control. For reference, the Q meter and capacitance dial readings are noted. The shorting strap is then disconnected (or removed) and resonance of the measuring circuit is again taken by adjusting the L/C dial. The parameter values of the unknown can be derived from the Q meter and capacitance dial readings obtained before and after disconnecting the shorting strap. The derivation of the parameter values related to the unknown are described in paragraphs 3-73 through 3-81.</p>

Direct Connection Measurements

3-30. BASIC Q METER MEASUREMENTS.

3-31. QUALITY FACTOR AND INDUCTANCE MEASUREMENTS (DIRECT CONNECTION).

3-32. This paragraph and those which follow describe the fundamental operating procedures for quality factor and inductance measurements which are typical applications of the Q Meter. An inductor usually has some distributed capacitance (Cd). The self-resonant frequency (fo) of the inductor is determined by its self-inductance and the Cd. The 4342A measuring circuit consideration of distributed capacitance is shown in Figure 3-7. If the Q meter indication is Qt when Cd is zero, then the presence of Cd will influence the voltage across the resonating inductor such that the Q meter will actually indicate a Q value lower than Qt. The indicated Q value (Qi) and the Qt can be correlated by a correction factor (which is a function of Cd and the tuning capacitance) each with the other. A similar correction factor also applies to difference of inductance readings resulting from the presence of Cd. A detailed discussion of correction factors is given in paragraph 3-50. When the Cd is less than 1/20 of the tuning capacitance, the difference between Qi and Qt (Li and Lt are similar in meaning) is within 5%.

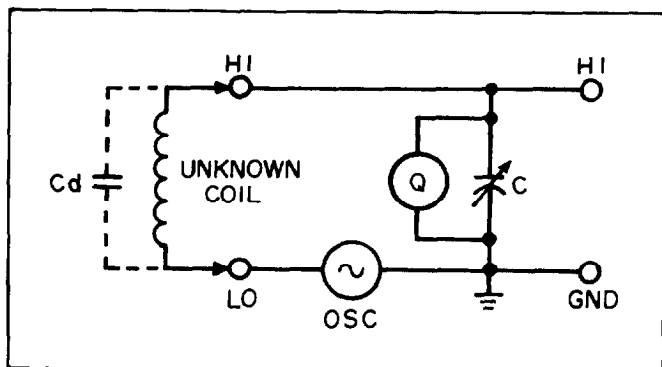

Figure 3-7. Distributed Capacitance in Direct Connection.

3-33. Q Measurement.

3-34. To read the quality factor of an inductance sample directly from the Q meter indication, proceed as follows:

- a. Connect unknown to measurement COIL (HI and LO) terminals.
- b. Depress an appropriate FREQUENCY RANGE button and set FREQUENCY dial control to the desired frequency.

- c. Adjust L/C dial control for maximum panel Q meter deflection on the instrument.

Note

Alternatively, the resonance may be taken by setting the L/C dial to a desired position and adjusting the FREQUENCY dial for maximum Q meter deflection.

- d. Depress Q RANGE button as appropriate for obtaining a Q meter deflection more than one-third of full scale and less than full scale.
- e. Re-adjust L/C dial (or FREQUENCY dial) control for maximum deflection. If panel meter deflection exceeds full scale, up-range the Q RANGE and continue the adjustment. For easily obtaining a precise resonance, use the ΔC dial control.

Note

The ΔC dial control facilitates accurate adjustment for establishing resonance especially in high Q measurements.

- f. Read panel Q meter indication on the meter scale designated by the appropriate scale lamp indicator lit.

Note

The measured Q value corresponds to the "indicated Q" of the sample.

- g. To derive series equivalent resistance of the sample, substitute the Q meter FREQUENCY, C dial, ΔC dial, and Q readings in the following equation:

$$R_s = 1/\omega C Q \approx 0.159/f C Q \dots \dots \text{(eq. 3-2)}$$

Where, R_s : equivalent series resistance in ohms.
 f : frequency dial reading in hertz.
 ω : 2π times the frequency ($2\pi f$).
 C : sum of C and ΔC dial readings in farads.
 Q : panel Q meter reading.

Direct Connection Measurements

3-35. ΔQ Measurement.

3-36. When two Q values are nearly identical, the difference is difficult to read accurately on the normal Q scale. The ΔQ feature of the 4342A provides accurate readings for changes in Q on all Q ranges by providing ten times resolution, namely: 0 to 3, 0 to 10, 0 to 30, and 0 to 100. To make a ΔQ measurement, proceed as follows:

- a. Connect the sample inductor to the measurement COIL (HI and LO) terminals.
- b. Resonate the inductor using the same procedure as described in Q Measurement (para. 3-34) steps b, c, d and e.
- c. Note panel Q meter reading.
- d. Depress ΔQ button and set ΔQ COARSE and FINE controls so that meter pointer indicates zero (full scale) on ΔQ scale.
- e. Check for correct resonance by slightly rotating ΔC dial control. If Q meter deflection is not at peak, re-adjust ΔC dial and ΔQ controls.
- f. Make the desired change in the sample or in the measuring circuit.
- g. Adjust L/C dial control for maximum Q meter deflection. Use ΔC dial control for easily taking a precise resonance. If meter pointer scales out at the left end of the scale (ΔQ full scale), reset the function to normal Q measurement and skip steps h and i.
- h. Read panel Q meter indication on ΔQ scale. The ΔQ reading is the difference in Q resulting from the change made in step f.
- i. The differential Q value (after change) is given by the following equation:
$$Q_2 = Q_1 - \Delta Q \dots\dots\dots \text{(eq. 3-3)}$$
where, Q_1 : Q meter reading in step c (before change).
 Q_2 : present Q value (after change).
 ΔQ : Q meter reading from ΔQ scale in step h.
- j. When the change in Q exceeds ΔQ full scale, the difference is given by the following equation:
$$\Delta Q = Q_1 - Q_2 \dots\dots\dots \text{(eq. 3-4)}$$

3-37. Inductance Measurement.

3-38. The inductance of a coil can be measured directly from the Q meter inductance scale at specific "L" frequencies. The inductance range which may be measured directly at the "L" scale frequency point on the selected frequency range is labeled on the panel adjacent to the FREQUENCY RANGE push-buttons. To measure inductance at the "L" frequency, proceed as follows:

- a. Connect unknown to measurement COIL (HI and LO) terminals.
- b. If the approximate value of inductance is known, select an appropriate measuring frequency range. Refer to the chart in Figure 3-4 or the inductance multiplier label adjacent to the FREQUENCY RANGE pushbuttons. For the samples whose values are quite unknown, select a trial frequency range. Depress the selected frequency range pushbutton.
- c. Set FREQUENCY dial control for the "L" scale frequency designated by the mark "-L-" (shown in blue) on the FREQUENCY scale.
- d. Set Q RANGE to 100. Rotate L/C dial control and verify that panel Q meter indicates peak deflection. If a peak meter deflection can not be recognized, change to another trial FREQUENCY RANGE setting and repeat the procedure until a peak is verified.
- e. Set ΔC dial to zero scale (0pF).
- f. Adjust L/C dial control for maximum Q meter deflection (change Q RANGE setting as necessary).
- g. Read L/C dial L scale indicated by the fixed scale pointer. To calculate the inductance value, multiply the L scale reading by the factor for the selected inductance range.

Note

The measured value corresponds to the "indicated L" including measuring circuit residual factors (similar to "indicated Q" value).

3-39. Inductance Measurement (at a desired frequency).

3-40. Occasionally it may be necessary to measure inductance at frequencies other than the specific "L" frequencies. The frequency characteristic measurements of an inductor or of an inductor core are representative examples. In such instances, the inductance may be measured as follows:

- a. Connect unknown inductor and resonate it using the procedure same as described in Q Measurement (para. 3-34) steps a through e.
- b. Note FREQUENCY dial, L/C dial C scale and ΔC dial readings. Substitute these values in the following equation:

$$L = 1/\omega^2 C \approx 0.0253/f^2 C \dots\dots \text{(eq. 3-5)}$$

- Where, L: inductance value (indicated L) of sample in henries.
- f: measurement frequency in hertz.
- ω : 2π times the measurement frequency.
- C: sum of C and ΔC dial readings in farads.

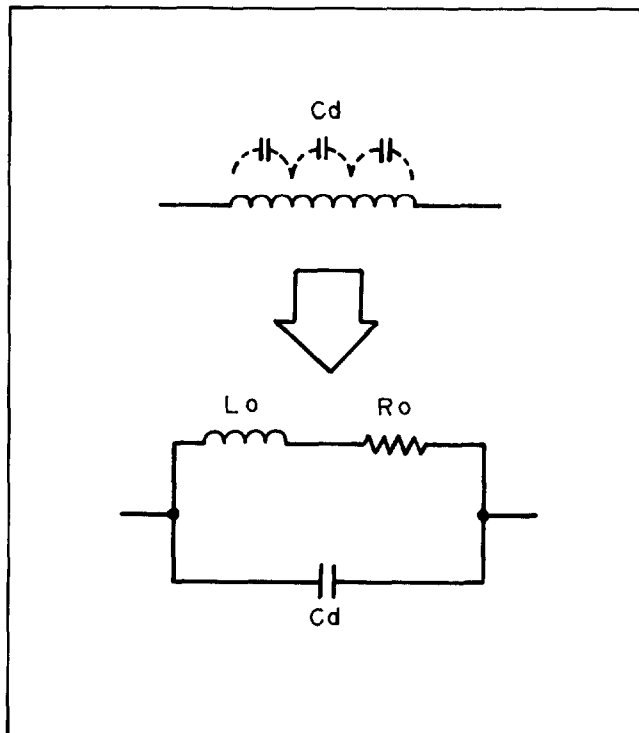

Figure 3-8. Distributed Capacitance Circuit Model.

3-41. MEASUREMENTS REQUIRING CORRECTIONS.

3-42. Effects of Distributed Capacitance.

3-43. The presence of distributed capacitances in a sample influences Q meter indications with a factor that is related to both its capacity and the measurement frequency. Considerations for the distributed capacitances in an inductor may be equivalently expressed as shown in Figure 3-8. In the low frequency region, the impedance of the distributed capacitance Cd is extremely high and has negligible effect on the resonating circuit. Thus, the sample measured has an inductance of Lo, an equivalent series resistance of Ro, and a Q value of $\omega Lo/Ro$ (where, ω is 2π times the measurement frequency). In the high frequency region, the inductor develops a parallel resonance with the distributed capacitance and the impedance of the sample increases at frequencies near the resonant frequency. Therefore, readings for measured inductances will be higher as the measurement frequency gets closer to the self-resonant frequency. Additionally, at parallel resonance, the equivalent series resistance is substantially increased (this is because, at resonance, the impedance of the sample changes from reactive to resistive because of the phase shift in the measurement current) and the measured Q value reading is lower than that determined by $\omega Lo/Ro$. Typical variations of Q and inductance values under these conditions are given in Figure 3-9.

3-44. Ratio of the measurement frequency and the self-resonant frequency can be converted to a distributed capacitance and tuning capacitance relationship with the following equation:

$$f_1/f_0 = \sqrt{Cd/(C + Cd)} \dots\dots \text{(eq. 3-6)}$$

- Where, f_1 : measurement frequency.
- f_0 : self-resonant frequency of sample.
- Cd: distributed capacitance of sample.
- C: tuning capacitance of Q meter.

Figure 3-10 graphically shows the variation of measured Q and inductance as capacitance is taken for the parameter. The ideal inductance and Q values in the presence of no distributed capacitance (or when it is negligible) are correlated with the actually measured values by correction factors which correspond to readings along the vertical axis scales in Figures 3-9 and 3-10.

Measurements Requiring Corrections

3-45. Measuring Distributed Capacitance
 (Preferred Method).

3-46. The impedance of a coil at its self-resonant frequency is resistive and usually high. This characteristic may be utilized for measuring distributed capacitance. Proceed as follows:

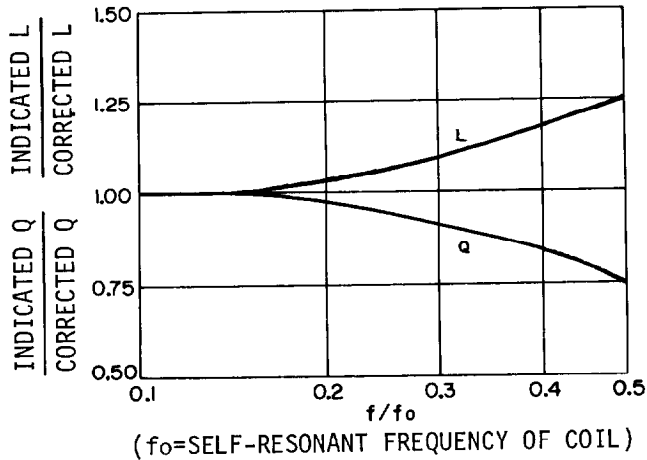

Figure 3-9. Typical Variation of Effective Q and Inductance with Frequency.

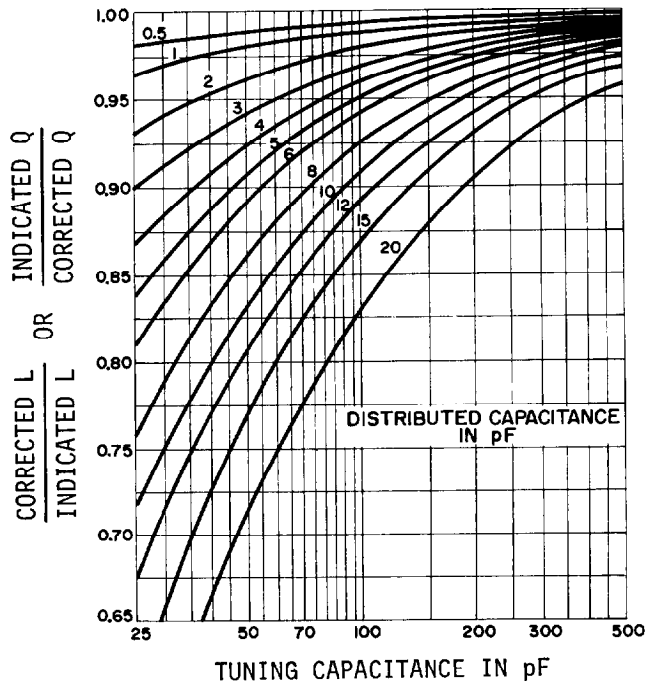

Figure 3-10. Correction Chart for Distributed Capacitance.

- a. Connect inductor sample to be tested to the 4342A measurement COIL (HI and LO) terminals.
- b. Set L/C dial control to approximately 400pF and ΔC dial control to OpF. Note C dial reading as C₁.
- c. Depress a trial FREQUENCY RANGE button and rotate FREQUENCY dial to search for the frequency at which panel Q meter shows a maximum deflection. If no peak deflection can be observed, change FREQUENCY RANGE setting and repeat the procedure.
- d. Adjust FREQUENCY dial control for maximum Q meter deflection. Note the dial frequency reading as f₁.
- e. Set measurement frequency to approximately ten times the frequency f₁ noted in step d.
- f. Replace the inductor sample with a stable coil (16470 series supplemental inductor) capable of resonating in the measuring circuit at this higher frequency.
- g. Adjust the L/C dial control for maximum Q meter deflection.
- h. Connect the test inductor to the measurement CAPACITOR (HI and GND) terminals.
- i. Adjust the L/C dial control for again obtaining maximum Q meter deflection. If the L/C dial control has to be rotated in the direction of higher capacitance, increase the measurement frequency. If it has to be rotated towards a lower capacitance, decrease the frequency.
- j. Alternately connect and disconnect the test inductor to/from the CAPACITOR terminals and adjust the FREQUENCY dial control (if necessary, change FREQUENCY RANGE setting) until the influence of the test inductor to tuning conditions is non-existent (indicated Q value may change). Note dial frequency reading as f₀. This frequency is identical with the self resonant frequency of the inductor.
- k. Distributed capacitance of the inductor sample is given by the following equation. Substitute measured values of C₁, f₀, and f₁ in the equation:

Measurements Requiring Corrections

$$C_d = \frac{C_1}{\left(\frac{f_0}{f_1}\right)^2 - 1} \dots\dots\dots \text{(eq. 3-7)}$$

- Where, C_d : distributed capacitance in farads.
 C_1 : C dial reading (farads) noted in step b.
 f_0 : measurement frequency (hertz) noted in step j.
 f_1 : measurement frequency (hertz) noted in step d.

Note

If $f_0 \gg f_1$, the eq. 3-7 is simplified as follows:

$$C_d = \left(\frac{f_1}{f_0}\right)^2 C_1 \dots\dots\dots \text{(eq. 3-7)}$$

3-47. Measuring Distributed Capacitance (Approximate Method, $C_d \geq 10\text{pF}$).

3-48. A distributed capacitance more than approximately 10pF may be measured with the simplified procedure described below (this procedure is useful for obtaining approximate values of distributed capacitance with an accuracy which serves practical purposes):

- a. Connect inductor sample to the measurement COIL (HI and LO) terminals.
- b. Set L/C dial control to approximately 50pF and ΔC dial control to 0pF. Note the C dial reading as C_1 .
- c. Depress a trial FREQUENCY RANGE button and rotate FREQUENCY dial control to search for the frequency at which panel Q meter shows a maximum deflection. If no peak deflection can be observed, change FREQUENCY RANGE setting and repeat the procedure.
- d. Adjust FREQUENCY dial control for maximum panel Q meter deflection. Note this frequency as f_1 .
- e. Change FREQUENCY dial setting to f_2 equal to f_1/n (n should be a selected integer, e.g. 2 or 3).
- f. Adjust L/C dial and ΔC dial controls for again obtaining maximum meter deflection. Note the sum of C dial and ΔC dial readings as C_2 .

- g. Distributed capacitance is given by the following equation. Substitute measured values of C_1 , C_2 , f_1 and f_2 in the equation:

$$C_d = \frac{(C_2 - n^2 C_1)}{n^2 - 1} \dots\dots\dots \text{(eq. 3-9)}$$

$$n = \frac{f_1}{f_2}$$

- Where, C_d : distributed capacitance in farads.
 C_1 : C dial reading (farads) noted in step b.
 C_2 : C dial reading (farads) noted in step f.
 f_1 : measurement frequency (hertz) noted in step d.
 f_2 : measurement frequency (hertz) given in step e.

Note

If f_2 is exactly one half of f_1 , then

$$C_d = \frac{C_2 - 4C_1}{3} \dots\dots\dots \text{(eq. 3-10)}$$

An average of several measurements using different values of C_1 will improve the results of this measurement. The best accuracy to be expected with this method, however, is in the range of $\pm 2\text{pF}$.

3-49. CORRECTION FOR Q.

3-50. To use the indicated Q for the purpose of calculating L and R_s (in determining the actual equivalent circuit), it must be corrected for the effects of the distributed capacitance. The corrected Q and the Q value measured by the Q meter can be obtained from the following equation:

$$Q_t = Q_i \frac{C + C_d}{C} \dots\dots\dots \text{(eq. 3-11)}$$

Then,

$$\text{Correction factor} = \frac{C + C_d}{C} = 1 + \frac{C_d}{C} \dots\dots\dots \text{(eq. 3-12)}$$

- Where, Q_t : corrected Q value.
 Q_i : indicated Q value.
 C : sum of C and ΔC dial readings.
 C_d : distributed capacitance of sample.

Measurements Requiring Corrections

Figure 3-10 is a graphical solution to equation 3-11. The corrected Q value Q_t may be deemed the quality factor calculated as $\omega L_o/R_o$ from inductance L_o , equivalent series resistance R_o , and the measurement frequency (refer to paragraph 3-43). However, Q_t is not identical to "effective Q". The corrected Q is also a "circuit Q" which includes the additional losses of the measuring circuit.

3-51. By substituting equation 3-6 in equation 3-11, the correction factor in equation 3-11 can be converted into a relationship of measurement frequency and self resonant frequency of sample. And the corrected quality factor may be expressed as follows:

$$Q_t = Q_i \frac{1}{1 - \left(\frac{f_1}{f_0}\right)^2} \dots\dots\dots \text{(eq. 3-13)}$$

Where, f_1 : measurement frequency.
 f_0 : self resonant frequency of sample.

A graphic expression of the above equation is shown in Figure 3-9. When f_1 is greater than f_0 , equation 3-13 produces a negative Q_t . However, this negative Q has no meaning and should not be used. A negative Q is obtained when the reactance of the sample becomes capacitive (effect of distributed capacitance) instead of inductive at frequencies above f_0 .

3-52. CORRECTION FOR INDUCTANCE.

3-53. The residual inductance of the measuring circuit is included in the measured inductance of sample. When the sample value is in the vicinity of 0.5 μ H or less, the measured inductance should be compensated for such residual inductance. This compensation can be made simply by subtraction as follows:

$$L_m = L_i - L_{res} \dots\dots\dots \text{(eq. 3-14)}$$

Where, L_m : measured value excluding residual inductance.
 L_i : measured inductance.
 L_{res} : residual inductance of measuring circuit.

The L_{res} in the 4342A is approximately 0.01 μ H.

3-54. Correction of the measured inductance to arrive at a true model of the equivalent circuit of the sample also requires a correction for the distributed capacitance (similar to the correction in para. 3-50 for indicated Q). The corrected inductance value is given by the following equation:

$$L_t = L_i \frac{C}{C + C_d} \dots\dots\dots \text{(eq. 3-15)}$$

Where, L_t : corrected inductance value.
 L_i : indicated inductance value.
 C : sum of C and ΔC dial readings.
 C_d : distributed capacitance of sample.

Equation 3-15 may be converted into a frequency form as follows:

$$L_t = L_i \left\{ 1 - \left[\frac{f_1}{f_0} \right]^2 \right\} \dots\dots \text{(eq. 3-16)}$$

Where, f_1 : measurement frequency
 f_0 : self resonant frequency of sample.

Graphic solutions of equations 3-15 and 3-16 are shown in Figures 3-10 and 3-9, respectively.

3-55. PARALLEL AND SERIES CONNECTION MEASUREMENT METHODS.

3-56. GENERAL.

3-57. In practical applications of the Q meter, the expanded measurement capabilities of parallel and series connection measurements yield various advantages. For example, the parallel method permits measuring inductor samples at frequencies about its self-resonant frequency (f_0). In addition, inductance just below resonance, impedance at resonance, and apparent capacitance above f_0 can be measured. This is especially useful for measurement of inductors which are designed to resonate with tuning capacitors less than 20pF at their respective nominal working frequencies. A great number of coils known as "peaking coils" fall into this category. If there is no requirement for particular measurement conditions, the coil can be measured using the direct connection method. Here, the measurement parameter values may be read directly from Q meter indications. However, if the sample requires measurement with a tuning capacitance of less than 20pF, a direct measurement is impossible (due to the minimum capacitance of the tuning capacitor). A parallel measurement will provide the desired data eliminating the limitations of the direct connection method.

3-58. Sometimes parallel or series connection measurements offer improved measurement accuracies. At first glance, these measurement configurations appear to be incompatible with the stray capacitance, residual inductance and other unwanted additional factors incident in the use of supplemental equipment

such as reference inductors and the test terminal adapter. Actually, these residual factors do not contribute additional errors in the measurement results. In quality factor measurements, the "indicated Q" values obtained by parallel or series methods are usually a better approximation of "effective Q" than those obtained by direct methods. As the differences between the measured values and the effective values decrease further to small orders of magnitude, parallel and series methods are sometimes also used for samples which can be measured by direct methods.

3-59. Measured values in parallel and series methods are theoretically given only by the variable quantities which yield to differences in tuning conditions before and after connecting the sample. The constant quantities in the measuring circuit, which do not vary for the duration of measurement, are not factors in the results of the calculations for the individual measurement parameters. Since residual impedances in measuring circuit as well as inherent values of reference inductors are almost constant, these values are mathematically eliminated and also do not influence the measurement results. So, what additional measurement errors are contributed by the parallel and series methods? Let's discuss them in detail.

3-60. Additional Error Discussion.

3-61. Certain residual impedance elements change with the method of connection of the sample; in addition, the residual impedance also depends upon the mutual distances between the sample and the individual components of the measurement apparatus. Typical circuit models showing such residual factors are illustrated in Figure 3-11. C_4 and C_5 in

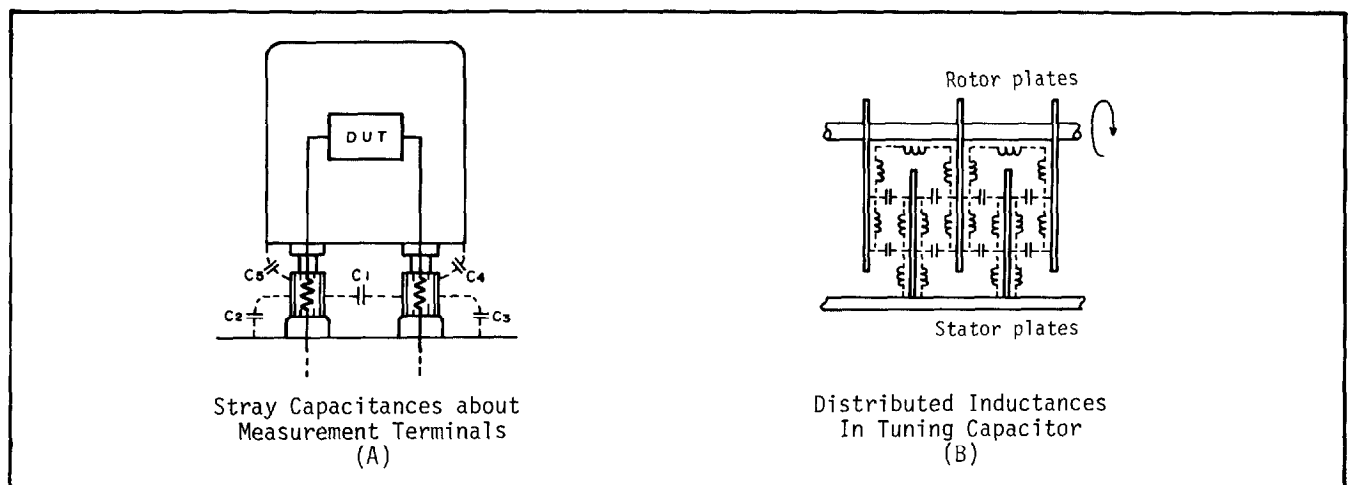

Figure 3-11. Residual Parameters.

Figure 3-11 (A) exhibit the stray capacities added by connecting a sample with a shielded case. This capacitance increase adds to the stray capacitances (C_1 , C_2 and C_3) around the measurement terminals. In a series measurement, the shorting strap, for initially short-circuiting the unknown connection terminals, has its own residual impedance. Additionally, its contact resistances differ from those of samples. Small changes in the loss and the distributed inductance of the tuning capacitor affect measurement accuracies. Figure 3-11(B) graphically shows an electrical model of a variable capacitor. The distributed inductance and the loss varies depending on the position of the capacitor rotor. In the 4342A, these residual factors are minimum because specially designed, high quality variable capacitors are employed in the tuning circuit.

Actually, the residual impedances present in the measuring circuit do not cause significant errors except when measurements of extremely high or extremely low impedance samples are taken at high frequency. A full consideration of the factors of additional errors is not practical except in cases where the experiment requires improved accuracies. However, it is difficult to make an accurate Q measurement above 1000 (effective Q) at a frequency higher than about 1MHz.

3-62. In parallel and series measurements, Q meter indications are read twice as often as those in direct method measurements; thus, the accumulation of reading errors and instrumental errors should be taken into consideration. In addition, a more accurate tuning operation is required to minimize these additional errors. To improve frequency accuracy, the oscillator frequency may be monitored with a frequency counter (using FREQUENCY MONITOR output at rear panel).

3-63. When a low Q sample is measured, the Q meter deflection increases and decreases broadly during the tuning operation. Because of this low resonance sharpness, it is usually difficult to do exact tuning (to get a resonant peak) and to obtain correct indications. This limits the resistance value measurable with parallel and series methods, respectively, as shown in Figure 3-5. As high series resistance and low parallel resistance make for very low Q resonance circuits (below 10), the measurement accuracies for such samples are thus much lower.

3-64. PARALLEL MEASUREMENTS.

Note

In the following parallel connection measurement procedures, set 4342A Q RANGE as appropriate unless specially instructed otherwise.

3-65. High Inductance Measurement.

3-66. When the measuring circuit is resonated using a reference inductor and then the sample (unknown) inductor placed in parallel with the tuning capacitor, the tuning frequency will increase. To restore resonance at the measurement frequency, the tuning capacitance must be increased. The inductance of the unknown inductor can be determined from relationship of the tuning capacitances at the same measurement frequency. After the sample is connected, quality factor and equivalent parallel resistance can also be calculated from a reduction of the panel Q meter indication.

To measure an inductance sample by the parallel method, proceed as follows:

- a. Depress appropriate FREQUENCY RANGE pushbutton and set FREQUENCY dial control for desired measurement frequency.
- b. Select a reference inductor which allows the measuring circuit to resonate with a tuning capacitance of 30pF to 70pF at this frequency. Connect it to measurement COIL (HI and LO) terminals.
- c. Adjust L/C dial and ΔC dial controls for a maximum Q meter deflection. Note sum of the C dial and ΔC dial readings as C_1 and panel meter reading as Q_1 .
- d. Depress ΔQ button and adjust ΔQ ZERO (COARSE and FINE) controls so that meter pointer indicates zero (full scale) on ΔQ scale.

Note

Press ΔQ button to release ΔQ function and recheck for correct resonance. Again depress the ΔQ button and recheck for ΔQ zero indication.

Parallel Connection Measurements

- e. Connect unknown inductor to measurement CAPACITOR (HI and GND) terminals.
- f. Restore resonance by adjusting the L/C and ΔC dial controls. Note sum of the C dial and ΔC dial readings as C₂ and panel meter ΔQ reading. If meter pointer scales out at the left end of the scale (ΔQ full scale), reset the function for normal Q measurement. The difference in Q is calculated from the two Q values as ΔQ = Q₁ - Q₂.

- g. Inductance of the unknown inductor is:

$$L = \frac{1}{\omega^2(C_2 - C_1)} \text{ (H) } \dots\dots \text{ (eq. 3-17)}$$

Where, ω = 2π times the measurement frequency.

Q value of the unknown is:

$$Q = \frac{Q_1 Q_2 (C_2 - C_1)}{\Delta Q C_1} \dots\dots\dots \text{ (eq. 3-18)}$$

Where, ΔQ = Q₁ - Q₂

Equivalent parallel resistance is:

$$R_p = \frac{Q_1 Q_2}{\omega C_1 \Delta Q} \text{ (Ω) } \dots\dots\dots \text{ (eq. 3-19)}$$

- h. The capacitance required to tune the coil at the measuring frequency is simply,

$$C = C_2 - C_1 \dots\dots\dots \text{ (eq. 3-20)}$$

Note

If the measurement frequency is higher than the self-resonant frequency of the unknown inductor, the unknown will not appear inductive but capacitive, and C₂ will be less than C₁. Apparent capacitance of the unknown in such frequency region is:

$$C_a = C_1 - C_2 \dots\dots\dots \text{ (eq. 3-21)}$$

and equivalent parallel conductance is

$$G_a = \frac{\omega C_1 \Delta Q}{Q_1 Q_2} \dots\dots\dots \text{ (eq. 3-22)}$$

3-67. Low Capacitance Measurement (<450pF)

3-68. When the measuring circuit is re-sonated using a reference inductor, a capacitor placed in parallel with the tuning capacitor will lower the tuning frequency. To restore resonance at the measurement frequency, the tuning capacitance must be reduced as much as the capacitance of the sample. Hence, the sample value can be determined by noting the difference between the tuning capacitor dial readings. After the sample is connected, quality factor and equivalent parallel resistance can be calculated from a reduction of panel Q meter indication.

To measure a capacitance sample, proceed as follows:

- a. Select a reference inductor which can resonate at the desired measurement frequency and connect it to measurement COIL (HI and LO) terminals.
- b. Set L/C dial control to desired tuning capacitance and ΔC dial to zero. Note the tuning capacitance C₁.

Note

If the approximate value of the capacitor sample is known, select a value for C₁ such that the difference between C₁ and the sample value is 30 to 100pF.

- c. Depress appropriate FREQUENCY RANGE button and adjust FREQUENCY dial control for a maximum Q meter deflection. Note frequency f₁ and panel Q meter reading Q₁.
- d. Depress ΔQ button and adjust ΔQ ZERO (COARSE and FINE) controls so that meter pointer indicates zero (full scale) on ΔQ scale.

Note

Press ΔQ button to release ΔQ function and recheck for correct resonance. Again depress the ΔQ button and recheck for ΔQ zero indication.

- e. Connect the unknown capacitor to measurement CAPACITOR (HI and GND) terminals.
- f. Restore resonance by adjusting the L/C and ΔC dial controls. Note sum of the L/C dial and ΔC dial readings as C₂ and panel meter ΔQ reading. If meter

Parallel Connection Measurements

pointer scales out at the left end of the scale (ΔQ full scale), reset the function to normal Q measurement. The difference in Q is calculated from the two Q values as $\Delta Q = Q_1 - Q_2$.

- g. Capacitance value of the unknown capacitor is:

$$C_p = C_1 - C_2 \dots\dots\dots (\text{eq. 3-23})$$

Q value of the unknown is:

$$Q = \frac{Q_1 Q_2 (C_1 - C_2)}{\Delta Q C_1} \dots\dots\dots (\text{eq. 3-24})$$

where, $\Delta Q = Q_1 - Q_2$

and equivalent parallel resistance of the unknown is:

$$R_p = \frac{Q_1 Q_2}{\omega C_1 \Delta Q} (\Omega) \dots\dots\dots (\text{eq. 3-25})$$

where, $\omega = 2\pi f_1$.

3-69. High Resistance Measurement.

3-70. When the measuring circuit is resonated using a reference inductor, a resistor placed in parallel with the tuning capacitor will lower the indicated Q in inverse proportion to the sample value. This reduction of Q is utilized to measure the resistance. To avoid a significant increment of measurement error, the measurement should be made for resistors within a reasonable range. For high resistances, the change in the indicated Q should be greater than the Q meter resolution, that is, 0.1 on $\Delta Q = 3$ range, 0.3 on 10 range, 1 on 30 range and 3 on 100 range, respectively. For relatively low resistances, the indicated Q should be higher than 10 when the sample is connected. See Figure 3-5 for suitable sample value ranges.

To measure high resistances, proceed as follows:

- a. Depress appropriate FREQUENCY RANGE button and set FREQUENCY dial control to the desired frequency.
- b. Connect a suitable reference inductor to measurement COIL (HI and LO) terminals.
- c. Adjust L/C dial and ΔC dial controls for maximum panel Q meter deflection. Note sum of the C dial and ΔC dial readings as C_1 and panel meter reading Q_1 .

Note

The reference inductor should be selected so that high resistances are measured with a low tuning capacitance and relatively low resistances are measured with a high tuning capacitance.

- d. Depress ΔQ button and adjust ΔQ ZERO (COARSE and FINE) controls so that meter pointer indicates zero (full scale) on ΔQ scale.

Note

Press ΔQ button to release ΔQ function and recheck for correct resonance. Again depress the ΔQ button and recheck for ΔQ zero indication.

- e. Connect the unknown resistor to measurement CAPACITOR (HI and GND) terminals.

- f. Restore resonance by adjusting the L/C and ΔC dial controls. Note sum of the C dial and ΔC dial readings as C_2 and panel meter ΔQ reading. If meter pointer scales out at the left end of the scale (ΔQ full scale), reset the function to normal Q measurement. The difference in Q is calculated from the two Q values as $\Delta Q = Q_1 - Q_2$.

- g. The resistance of the unknown resistor is:

$$R_p = \frac{Q_1 Q_2}{\omega C_1 \Delta Q} (\Omega) \dots\dots\dots (\text{eq. 3-26})$$

Where, $\omega = 2\pi$ times the measurement frequency.

If the sample is also reactive, its reactance is:

$$X_p = \frac{1}{\omega(C_2 - C_1)} (\Omega) \dots\dots (\text{eq. 3-27})$$

(usually capacitive)

and its capacitance is:

$$C_p = C_1 - C_2 \dots\dots\dots (\text{eq. 3-28})$$

If the sample appears inductive, C_2 is larger than C_1 .

Parallel Connection Measurements

3-71. Dielectric Measurement.

3-72. The dielectric constant and dielectric loss of insulating materials can be measured by a method similar to and is basically a capacitance measurement. When a pair of parallel electrodes (air capacitor) connected to 4342A (in air) and an insulating material placed between the electrodes, the electrode capacitance increases in proportional to the specific inductive capacity (ϵ_s) of the sample material. The dielectric constant of the sample material is calculated as the product of ϵ_s and the vacuum dielectric constant ϵ_0 . Accordingly, the dielectric constant can be determined from the capacitance measurements made before and after placing the sample between the electrodes. Additionally, after the sample is mounted in the holder, the conductance of the sample can also be calculated from a reduction of the Q meter indication. To make easy and accurate dielectric measurements, it is recommended that the 16451A Dielectric Test Adapter be used with the 4342A. Typical characteristics of the 16451A are described in Table 3-2.

Materials to be measured with the 16451A should be less than 10mm in thickness and from 38 to 55mm in diameter. When measuring materials with a high dielectric constant or a large loss, it is usually best to prepare material in thicknesses greater than 3mm. On the other hand, when low loss material is to be measured, the material thickness should be less than 3mm. Materials measuring less than 0.5mm in thickness are usually difficult to measure.

To make dielectric measurements using the 16451A, proceed as follows:

- a. Depress the appropriate FREQUENCY RANGE button and set FREQUENCY dial control for the desired measurement frequency.
- b. Select a reference inductor which can resonate at the measurement frequency. Connect it to 4342A measurement COIL (HI and LO) terminals.
- c. Adjust L/C dial and ΔC dial controls for a maximum Q meter deflection. Note sum of the C dial and ΔC dial readings as C_1 and panel meter reading as Q_1 .
- d. Let the reference inductor remain in place (as is) and attach the 16451A to 4342A measurement CAPACITOR (HI and GND) terminals.
- e. Set 16451A electrode spacing as desired. However, if possible, it is best to set the electrode spacing dimension to about the same as the thickness of the material to be measured.
- f. Again resonate the measurement circuit by adjusting the L/C and ΔC dial controls. Note C dial and ΔC dial readings as C_2 and panel meter reading Q_2 .

Table 3-2. 16451A (4342A-K01) Typical Characteristics.

<p>Electrode Diameter: 38mm</p> <p>Electrode Spacing: 0 ~10mm variable</p> <p>Minimum vernier division: 0.02mm</p> <p>Residual Parameters: $C_0 \approx 5\text{pF}$ $G_0 < 0.4\mu\text{S}$ (at 10MHz) $L_0 \approx 40\text{nH}$</p> <p>Minimum measurable loss angle ($\tan \delta$):</p> <p style="text-align: center;">Approximately 1×10^{-4}</p>	
---	--

Parallel Connection Measurements

- g. Depress ΔQ button and adjust ΔQ ZERO (COARSE and FINE) controls so that meter pointer indicates zero (full scale) on ΔQ scale.

$$\epsilon = \epsilon_0 \cdot \epsilon_s$$

$$= \frac{T_x}{T_0} \times 8.85 \times 10^{-12} \text{ (F/m)}$$

..... (eq. 3-30)

Note

Press ΔQ button to release ΔQ function and recheck for current resonance. Again depress the ΔQ button and recheck for ΔQ zero indication.

Electrode capacitance with the sample material is:

$$C_x = \frac{1}{T_0} \text{ (pF)}$$

$$= C_4 - C_3 + \frac{1}{T_x} \text{ (pF) .. (eq. 3-31)}$$

- h. Place the sample material between 16451A electrodes. The sample material should be in close contact with electrodes. Note 16451A micrometer reading Tx (as thickness of the sample).

Where, the unit for Tx and To is cm.

Equivalent parallel conductance of the sample material is:

- i. Again adjust the L/C and ΔC dial controls for resonance. Note sum of the C dial and ΔC dial readings as C₃ and panel meter ΔQ reading. If meter pointer scales out at the left end of the scale (ΔQ full scale), reset the function for normal Q measurement. The difference in Q is calculated from the two Q values as ΔQ = Q₂ - Q₃.

$$G_x = 2\pi f C_1 \frac{\Delta Q}{Q_2(Q_2 - \Delta Q)}$$

$$= 2\pi f C_1 \left(\frac{Q_2 - Q_3}{Q_2 Q_3} \right) \text{ (pS) .. (eq. 3-32)}$$

Dielectric loss angle (dissipation factor) of the sample material is:

- j. Remove the sample material from between the 16451A electrodes.
- k. Let the L/C and ΔC dial settings remain as is, and reduce space between the 16451A electrodes until resonance again occurs. Note the micrometer reading as To.

$$\tan \delta = C_1 \cdot T_0 \frac{\Delta Q}{Q_2(Q_2 - \Delta Q)}$$

$$= \frac{C_1}{C_x} \cdot \frac{\Delta Q}{Q_2(Q_2 - \Delta Q)}$$

$$= G_x / 2\pi f C_x \text{ (eq. 3-33)}$$

Where, f is measurement frequency.

Note

If this procedure is a little difficult, let the distance between the 16451A electrodes remain the same as the thickness of the sample being measured and take resonance again by adjusting the L/C and ΔC dial controls. Note sum of the C and ΔC dial readings as C₄.

Note

$\frac{Q_2 - Q_3}{Q_2 Q_3}$ may be used instead of $\frac{\Delta Q}{Q_2(Q_2 - \Delta Q)}$ in equation 3-33.

Q value of the sample material is:

$$Q_x = 1/\tan \delta \text{ (eq. 3-34)}$$

- l. Calculation formulas of the dielectric constant, dielectric loss, and associated measurement parameter values are summarized below:
Specific inductive capacity of the sample material is:

Note

The theoretical formula for 16451A electrode capacitance is:

$$\epsilon_s = \frac{T_x}{T_0} \text{ (eq. 3-29)}$$

$$C = \frac{S \times 10^{-2}}{36\pi \times 10^9 \times T_0} \text{ (F)} = \frac{S}{3.6\pi T_0} \text{ (pF)}$$

where S is area of electrode (cm²).

Dielectric constant of the sample material is:

Since the size of the electrode is 3.8cm in diameter, C above can be shown to be 1/T₀ (pF).

Series Connection Measurements

3-73. SERIES MEASUREMENTS.

Note

In the following series connection measurement procedures, set 4342A Q RANGE as appropriate unless specifically instructed otherwise.

3-74. Low Inductance Measurement.

3-75. Measurement of small inductors at relatively low frequencies can not be made directly at the measurement COIL terminals. However, by using an external high Q capacitor (such as the 16462A Auxiliary Capacitor) connected in parallel with the tuning capacitor, resonance can be obtained at the desired frequency. A second method, which is explained here, is the series method. This method is recommended for measuring low value inductors without using an external capacitor (but with an external inductor).

When the measuring circuit is resonated using a reference inductor, the test inductor placed in series with the reference inductor will lower the tuning frequency. To restore resonance at the measurement frequency, the tuning capacitance must be reduced. The inductance of the unknown inductor can be determined from the relationship between the tuning capacitances at the same frequency. After the sample is connected, quality factor and equivalent series resistance can also be calculated from a reduction of panel Q meter indication. Proceed as follows:

- a. Depress the appropriate FREQUENCY RANGE button and set FREQUENCY dial control for the desired measurement frequency.
- b. Select a reference inductor which allows the measuring circuit to resonate with a tuning capacitance of approximately 400pF. Connect unknown inductor in series with the reference inductor (between measurement LO terminal and low potential end of the reference inductor) and to measurement COIL (HI and LO) terminals.

Note

If 16014A Series Loss Test Adapter is available, attach it to measurement COIL terminals. Connect the reference inductor to appropriate terminals of the 16014A and unknown inductor to 16014A series connection terminals.

- c. Short-circuit the unknown (series connection terminals) with a heavy (low impedance) shorting strap.
- d. Adjust L/C dial and ΔC dial controls for a maximum Q meter deflection. Note sum of the C dial and ΔC dial readings as C₁ and panel meter reading as Q₁.
- e. Depress ΔQ button and adjust ΔQ ZERO (COARSE and FINE) controls so that meter pointer indicates zero (full scale) on ΔQ scale.

Note

Press ΔQ button to release ΔQ function and recheck for correct resonance. Again depress the ΔQ button and recheck for ΔQ zero indication.

- f. Disconnect the shorting strap. Again resonate the measuring circuit by adjusting L/C dial and ΔC dial controls. Note sum of the C dial and ΔC dial readings as C₂ and panel Q meter ΔQ reading. If meter pointer scales out at the left end of the scale (ΔQ full scale), reset the function to normal Q measurement. The difference in Q is calculated from the two Q values as ΔQ = Q₁ - Q₂.

Note

This procedure (steps c, d and f) permits the unknown component to be physically connected even through it is electrically out of the circuit, and eliminates possible errors by maintaining the relative positions of the reference inductor and unknown component.

- g. Inductance of the unknown inductor is:

$$L_s = \frac{(C_1 - C_2)}{\omega^2 C_1 C_2} \text{ (H) } \dots \dots \text{ (eq. 3-35)}$$

Where, ω = 2π times the measurement frequency.

Q value of the unknown is:

$$Q = \frac{Q_1 Q_2 (C_1 - C_2)}{C_1 Q_1 - C_2 Q_2} \dots \dots \text{ (eq. 3-36)}$$

Where, Q₂ = Q₁ - ΔQ

Equivalent series resistance is:

$$R_s = \frac{\left(\frac{C_1}{C_2}\right) Q_1 - Q_2}{\omega C_1 Q_1 Q_2} \text{ (Ω) } \dots \dots \text{ (eq. 3-37)}$$

Series Connection Measurements

3-76. High Capacitance Measurement ($\geq 450\text{pF}$).

3-77. When the measuring circuit is resonated using a reference inductor, a test capacitor placed in series with the reference inductor will raise the tuning frequency. To restore resonance at the measurement frequency, the tuning capacitance must be increased. The capacitance of the unknown can be determined from the relationship between the tuning capacitances at the same frequency. After the sample is connected, quality factor and equivalent series resistance can be calculated from a reduction of panel Q meter indication.

To measure a capacitance sample, proceed as follows:

- a. Depress the appropriate FREQUENCY RANGE button and set FREQUENCY dial control for desired measurement frequency.
- b. Select a reference inductor which allows the measuring circuit to resonate with a tuning capacitance of approximately 200pF.

Note

If the sample value is higher than about 3600pF, it is recommended that the initial tuning capacitance setting be in the vicinity of 400pF to obtain better measurement accuracy.

Connect unknown capacitor in series with the reference inductor (between measurement LO terminal and low potential end of the reference inductor) and to measurement COIL (HI and LO) terminals.

Note

If 16014A Series Loss Test Adapter is available, attach it to measurement COIL terminals. Connect the reference inductor to appropriate terminals of the 16014A and unknown capacitor to 16014A series connection terminals.

- c. Short-circuit the unknown (series connection terminals) with a heavy (low impedance) shorting strap.
- d. Adjust L/C dial and ΔC dial controls for a maximum Q meter deflection. Note sum of the C dial and ΔC dial readings as C_1 and panel meter reading as Q_1 .

- e. Depress ΔQ button and adjust ΔQ ZERO (COARSE and FINE) controls so that meter pointer indicates zero (full scale) on ΔQ scale.

Note

Press ΔQ button to release ΔQ function and recheck for correct resonance. Again depress the ΔQ button and recheck for ΔQ zero indication.

- f. Disconnect the shorting strap. Again resonate the measuring circuit by adjusting L/C dial and ΔC dial controls. Note sum of the C dial and ΔC dial readings as C_2 and panel meter indication as ΔQ reading. If meter pointer scales out at the left end of the scale (ΔQ full scale), reset the function to normal Q measurement. The difference in Q is calculated from the two Q values as $\Delta Q = Q_1 - Q_2$.

Note

This procedure (steps c, d and f) permits the unknown component to be physically connected even through it is electrically out of the circuit, and eliminates possible errors by maintaining the relative positions of the reference inductor and unknown component.

- g. The capacitance of the unknown capacitor is:

$$C_s = \frac{C_1 C_2}{(C_2 - C_1)} \dots\dots\dots (\text{eq. 3-38})$$

Q value of the unknown is:

$$Q = \frac{Q_1 Q_2 (C_1 - C_2)}{C_1 Q_1 - C_2 Q_2} \dots\dots (\text{eq. 3-39})$$

Where, $Q_2 = Q_1 - \Delta Q$

Equivalent series resistance is:

$$R_s = \frac{Q_2 - \left\{ \frac{C_1}{C_2} \right\} Q_1}{\omega C_1 Q_1 Q_2} (\Omega) \dots (\text{eq. 3-40})$$

Where, $\omega = 2\pi$ times the measurement frequency.

3-78. Self-resonant Frequency Measurement of High Capacitors.

3-79. Capacitors have a residual inductance which is dependent on the capacitor lead

Series Connection Measurements

length and electrode structure. This inductance resonates with the capacitance of the capacitor at a high frequency. At this self-resonant frequency, the impedance of the capacitor is minimum owing to the series resonance which occurs in the capacitor itself. Hence, its self-resonant frequency determines the upper limit of the useable frequency for the capacitor. Usually the self-resonant frequency of electrolytic, tantalum, film, mylar capacitors and others which are within a capacitance range of about 5nF to 1μF can be measured with a Q meter.

When the capacitor self-resonates, the impedance is minimum and purely resistive. This characteristic is utilized to determine the self-resonant frequency and the equivalent series resistance at this frequency. The measurement procedure to determine the self-resonant frequency of a capacitor is similar to that for an inductor (described in paragraph 3-46). Proceed as follows:

- a. Depress a trial FREQUENCY RANGE button.

Note

For high capacitance samples, select either the 22k - 70k or the 70k - 220k range and, for a relatively low capacitance samples, select the 220k - 700k or the 0.7M - 2.2M range, respectively.

- b. Select a reference inductor which allows the measuring circuit to resonate with a tuning capacitance of approximately 400pF. Connect unknown capacitor in series with the reference inductor (between measurement LO terminal and low potential end of the reference inductor) and to measurement COIL (HI and LO) terminals.

Note

If 16014A Series Loss Test Adapter is available, attach it to measurement COIL terminals. Connect the reference inductor to appropriate terminals of the 16014A and unknown capacitor to 16014A series connection terminals.

- c. Short-circuit the unknown (series connection terminals) with a heavy (low impedance) shorting strap.
- d. Adjust FREQUENCY dial control for a maximum panel Q meter deflection.

- e. Disconnect the shorting strap. Again resonate the measuring circuit by adjusting the L/C dial control. If L/C dial control has to be rotated in the direction of higher capacitance, increase the measurement frequency. If it has to be rotated towards a lower capacitance, decrease the frequency.
- f. Repeat steps c, d, and e until the influence of the test capacitor to tuning condition is non-existent (indicated Q value may change).

Note

If such condition can not be obtained on the selected frequency range even though the L/C dial control is set to maximum, change FREQUENCY RANGE setting to upper range. If the L/C dial control must be reduced to less than 200pF, change FREQUENCY RANGE setting to a lower range. Replace reference inductor with another trial inductor and repeat steps a through f until the adjustment in step f succeeds.

- g. Note sum of C dial and ΔC dial readings as C_1 and dial frequency reading as f_0 . This frequency is identical with the self-resonant frequency of the unknown capacitor.
- h. Connect the shorting strap (if not already connected). Depress ΔQ button and adjust ΔQ ZERO (COARSE and FINE) controls so that meter pointer indicates zero (full scale) on ΔQ scale.

Note

Press ΔQ button to release ΔQ function and recheck for correct resonance. Again depress the ΔQ button and recheck for ΔQ zero indication.

- i. Disconnect the shorting strap. Note panel Q meter ΔQ reading. If meter pointer scales out at the left end of the scale (ΔQ full scale), reset the function to normal Q measurement. The difference in Q is calculated from the two Q values as $\Delta Q = Q_1 - Q_2$.
- j. Equivalent resistance of the capacitor at the resonant frequency is:

$$R_s = \frac{\Delta Q}{\omega C_1 Q_1 Q_2} (\Omega) \dots \dots \dots (\text{eq. 3-41})$$

Where, $\omega = 2\pi f_0$.

Series Connection Measurements

3-80. Low Resistance Measurement.

3-81. When measuring circuit is resonated using a reference inductor, a resistor placed in series with the reference inductor will lower the indicated Q in proportion to the resistance value of the sample. This reduction of Q is utilized to measure the resistance. To avoid a significant increment of measurement error, the measurement should be made for resistors within a reasonable range. For low resistance, the change in the indicated Q should be greater than the Q meter resolution, that is, 0.1 on $\Delta Q = 3$ range, 0.3 on 10 range, 1 on 30 range and 3 on 100 range, respectively. For high resistance, the indicated Q should be higher than 10 when the sample is connected. See Figure 3-5 for the suitable sample value range.

To measure low resistances, proceed as follows:

- a. Depress the appropriate FREQUENCY RANGE button and set FREQUENCY dial control for the desired measurement frequency.
- b. Select a suitable reference inductor so that relatively high resistances are measured with a low tuning capacitance and low resistances are measured with a high tuning capacitance. Connect unknown resistor in series with the reference inductor (between measurement LO terminal and low potential end of the reference inductor) and to measurement COIL (HI and LO) terminals.

Note

If 16014A Series Loss Test Adapter is available, attach it to measurement COIL terminals. Connect the reference inductor to appropriate terminals of the 16014A and unknown resistor to 16014A series connection terminals.

- c. Short-circuit the unknown (series connection terminals) with a heavy (low impedance) shorting strap.
- d. Adjust L/C dial and ΔC dial controls for a maximum Q meter deflection. Note sum of the C dial and ΔC dial readings as C_1 and panel meter reading as Q_1 .

- e. Depress ΔQ button and adjust ΔQ ZERO (COARSE and FINE) controls so that meter pointer indicates zero (full scale) on ΔQ scale.

Note

Press ΔQ button to release ΔQ function and recheck for correct resonance. Again depress the ΔQ button and recheck for ΔQ zero indication.

- f. Disconnect the shorting strap. Again resonate the measuring circuit by adjusting L/C dial and ΔC dial controls. Note sum of the C dial and ΔC dial readings as C_2 and panel meter as ΔQ reading. If meter pointer scales out at the left end of the scale (ΔQ full scale), reset the function to normal Q measurement. The difference in Q is calculated from the two Q values as $\Delta Q = Q_1 - Q_2$.

Note

This procedure (steps c, d and f) permits the unknown component to be physically connected even though it is electrically out of the circuit, and eliminates possible errors by maintaining the relative positions of the reference inductor and unknown component.

- g. The resistance of unknown resistor is:

$$R_s = \frac{\left(\frac{C_1}{C_2}\right) Q_1 - Q_2}{\omega C_1 Q_1 Q_2} (\Omega) \dots \text{(eq. 3-42)}$$

Where, $\omega = 2\pi$ times the measurement frequency.

$$Q_2 = Q_1 - \Delta Q$$

If the unknown is purely resistive ($C_2 = C_1$), the equation for resistance reduces to:

$$R_s = \frac{\Delta Q}{\omega C_1 Q_1 Q_2} (\Omega) \dots \text{(eq. 3-43)}$$

If the unknown is also reactive, the reactance is:

$$X_s = \frac{(C_1 - C_2)}{\omega C_1 C_2} (\Omega) \dots \text{(eq. 3-44)}$$

Table 3-3. Formulas for Calculating Q and Impedance Parameters from Parallel and Series Measurements.

Parallel Measurements	Series Measurements
<p>Effective Q of Unknown</p> $Q = \frac{Q_1 Q_2 (C_2 - C_1)}{\Delta Q C_1}$	<p>Effective Q of Unknown</p> $Q = \frac{Q_1 Q_2 (C_1 - C_2)}{C_1 Q_1 - C_2 Q_2}$
<p>Effective Parallel Resistance of Unknown</p> $R_p = \frac{Q_1 Q_2}{\omega C_1 \Delta Q}$	<p>Effective Series Resistance of Unknown</p> $R_s = \frac{\left(\frac{C_1}{C_2}\right) Q_1 - Q_2}{\omega C_1 Q_1 Q_2}$
<p>Effective Parallel Reactance of Unknown</p> $X_p = \frac{1}{\omega (C_2 - C_1)}$	<p>Effective Series Reactance of Unknown</p> $X_s = \frac{C_1 - C_2}{\omega C_1 C_2}$
<p>Effective Parallel Inductance of Unknown</p> $L_p = \frac{1}{\omega^2 (C_2 - C_1)}$	<p>Effective Series Inductance of Unknown</p> $L_s = \frac{C_1 - C_2}{\omega^2 C_1 C_2}$
<p>Effective Parallel Capacitance of Unknown</p> $C_p = C_1 - C_2$	<p>Effective Series Capacitance of Unknown</p> $C_s = \frac{C_1 C_2}{C_2 - C_1}$
<p>Note</p> <p>In the equation for Xp, the polarity (sign) of the quantity (C2-C1) indicates the effective reactance, a positive quantity indicates an inductive reactance and a negative quantity indicate a capacitive result.</p> <p>Disregard the sign of the quantity (C2-C1) in the equation above for Q.</p>	<p>Note</p> <p>In the equation for Xs, the polarity (sign) of the quantity (C1-C2) indicates the effective reactance, a positive quantity indicates an inductive reactance and a negative quantity indicate a capacitive result.</p> <p>Disregard the sign of the quantity (C1-C2) in the equation above for Q.</p>

Table 3-4. Formulas Relating Series and Parallel Components.

$Q = \frac{X_s}{R_s} = \frac{\omega L_s}{R_s} = \frac{1}{\omega C_s R_s} = \frac{R_p}{X_p} = \frac{R_p}{\omega L_p} = R_p \omega C_p = \frac{\sqrt{L}}{R_s} = \frac{R_p}{\sqrt{L}} \frac{1}{C}$					
PARALLEL TO SERIES CONVERSION	Formulas for Q greater than 10	Formulas for Q less than 0.1	SERIES TO PARALLEL CONVERSION	Formulas for Q greater than 10	Formulas for Q less than 0.1
$R_s = \frac{R_p}{1 + Q^2}$	$R_s = \frac{R_p}{Q^2}$	$R_s = R_p$	$R_p = R_s (1 + Q^2)$	$R_p = R_s Q^2$	$R_p = R_s$
$X_s = X_p \frac{Q^2}{1 + Q^2}$	$X_s = X_p$	$X_s = X_p Q^2$	$X_p = X_s \frac{1 + Q^2}{Q^2}$	$X_p = X_s$	$X_p = \frac{X_s}{Q^2}$
$L_s = L_p \frac{Q^2}{1 + Q^2}$	$L_s = L_p$	$L_s = L_p Q^2$	$L_p = L_s \frac{1 + Q^2}{Q^2}$	$L_p = L_s$	$L_p = \frac{L_s}{Q^2}$
$C_s = C_p \frac{1 + Q^2}{Q^2}$	$C_s = C_p$	$C_s = \frac{C_p}{Q^2}$	$C_p = C_s \frac{Q^2}{1 + Q^2}$	$C_p = C_s$	$C_p = C_s Q^2$

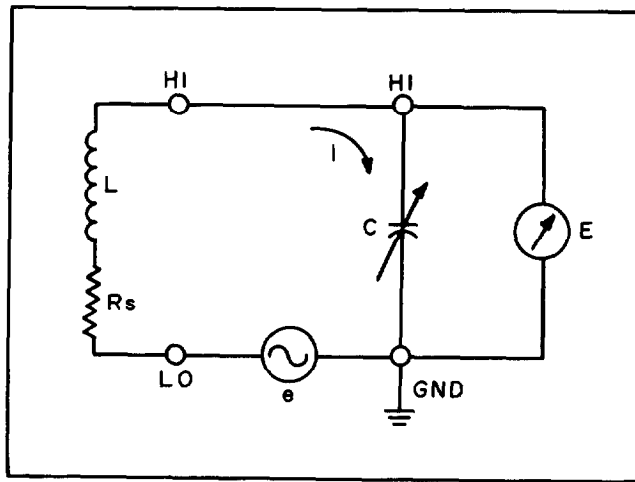

Figure 4-1. Series Resonant Circuit

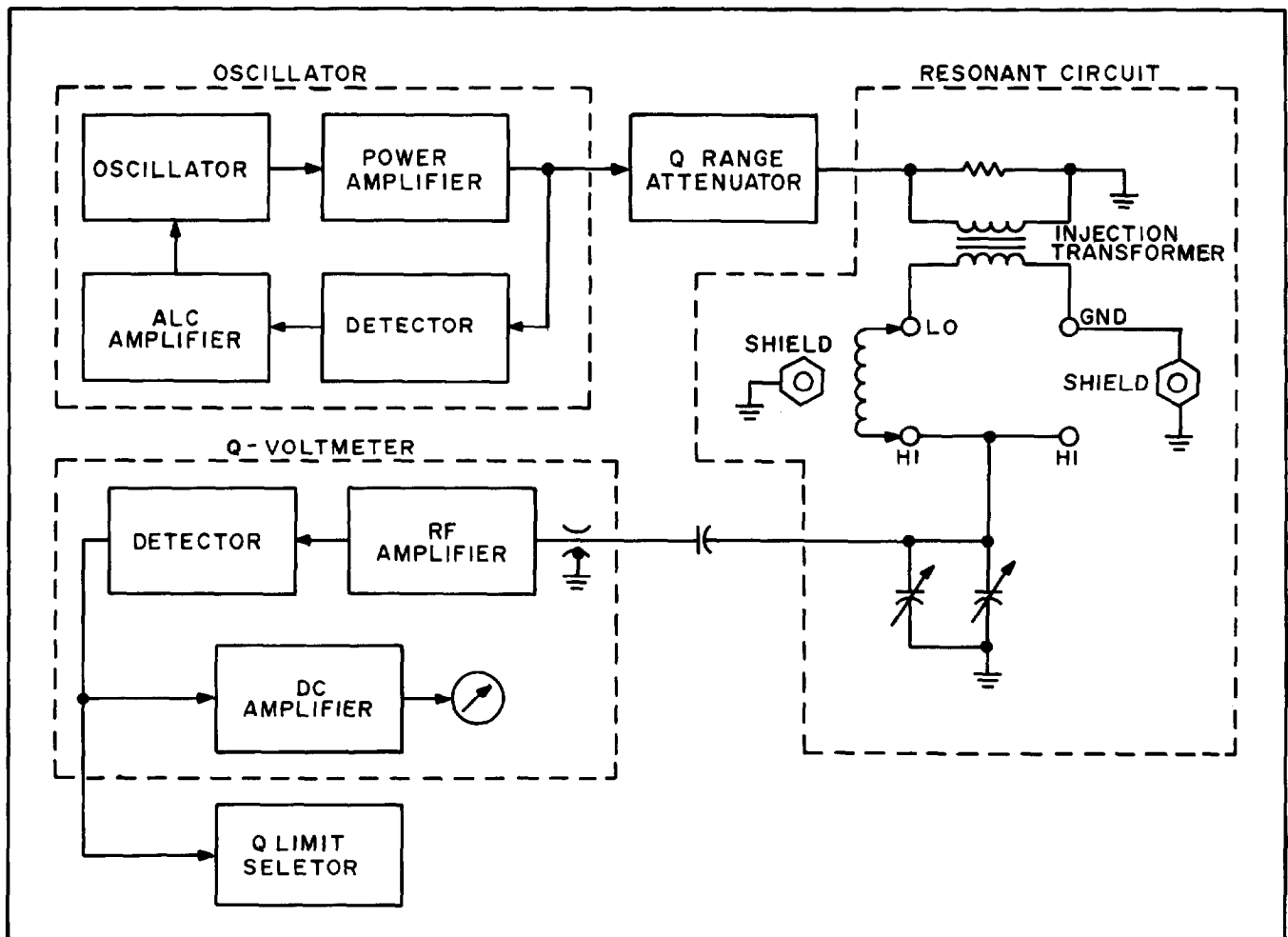

Figure 4-2. Model 4342A Simplified Block Diagram

SECTION IV

THEORY OF OPERATION

4-1. INTRODUCTION

4-2. This discussion of the HP Model 4342A Q Meter internal operation is divided into two parts: Block diagram description and circuit description. The block diagram section discusses the functions of the major circuits within the instrument, using the overall block diagram. The circuit description provides a detailed description of all the major circuits within the instrument. It is suggested that the block diagram and schematics which have been included in this manual be referred to while reading the circuit description. A Functional Overall Block Diagram of the instrument, showing all the major circuits and associated relevant information is provided in Section VIII at the back of the manual. Also in Section VIII, there are complete schematics of all the circuitry within the Model 4342A which include components, reference designators, and values.

4-3. Q DETERMINATION AND MEASUREMENT.

4-4. The ratio of a component's reactance to its resistance is measured by the Q meter. The magnitude of Q is usually considered a figure of merit expressing the ability of component to store energy compared to the energy it dissipates. A measure of Q is important to determine the RF resistance of components, the loss angle of capacitors, dielectric constants, transmission line parameters and antenna characteristics, etc. Q is a dimensionless number. In a circuit at resonance, Q can be defined as the ratio of total energy stored to the average power dissipated per cycle. For a single reactance component:

$$Q = X_s/R_s = R_p/X_p$$

Where X_s and X_p are series and parallel reactance and R_s and R_p are series and parallel resistance. The most common form of Q meter uses a series resonant circuit to measure Q, as shown in Figure 4-1.

4-5. When the variable air capacitor C is adjusted so that $X_c = X_L$, the only remaining impedance in the loop is R_s . The current that flows then is;

$$i = \frac{e}{R_s}$$

and the voltage E across capacitor C is;

$$E = \frac{e}{R_s} \cdot X_c \text{ and } \frac{E}{e} = \frac{X_c}{R_s} = \frac{X_L}{R_s} = Q$$

This equation is correct for values of $Q \geq 10$, for it can be shown that the true Q value being measured by the Q meter is equal to $\sqrt{1 + Q^2}$. Therefore, if e is held at a constant and known level, a voltmeter with high input impedance can be connected across the capacitor and calibrated directly in terms of Q. The e values in the above equations are functions of selected Q ranges. R_s is a function of the unknown inductor or Q reference coils. A detailed explanation

for the measurement of unknowns is provided in SECTION III.

4-6. SIMPLIFIED BLOCK DIAGRAM

4-7. The measurement principle used in the Model 4342A is the series resonant circuit. A simplified block diagram of the Q Meter is shown in Figure 4-2. The oscillator which covers 22kHz to 70MHz (10kHz to 32MHz in Option 001), is automatically leveled by a loop consisting of the detector and the ALC amplifier. The oscillator output is controlled automatically by comparing it to a fixed dc level. Thus, constant voltage is supplied to the Q-range attenuator. The attenuator adjusts the signal level according to the Q range settings. This signal is fed into the resonant circuit by a transformer (sometimes called an injection transformer). Resonance is achieved by adjusting the variable capacitor, and this level is read by the high-impedance voltmeter. Thus the Q value of the resonant circuit is indicated on the meter.

4-8. BLOCK DIAGRAM DESCRIPTION

4-9. The Model 4342A Q Meter performs Q measurement in the range of 5 to 1000 on coils in seven bands covering a frequency range from 22kHz to 70 MHz (10kHz to 32MHz in Option 001). The following paragraphs contain a brief outline of function of the major circuit groups in the Q Meter. Reference is made to the Functional Overall Block Diagram in SECTION VIII.

4-10. OSCILLATOR AND IMPEDANCE CONVERTER (A1A1)

4-11. The Oscillator circuit Q1-Q2 is a seven-band variable frequency oscillator covering a frequency range from 22kHz to 70MHz (10kHz to 32MHz in Option 001). The instrument utilizes a Hartley type circuit which operates from 22kHz to 22MHz (10kHz to 10MHz in Option 001) and a Colpitts type circuit from 22MHz to 70MHz (10MHz to 32MHz in Option 001). The FREQUENCY RANGE switch provides for the selection of the desired band of operation. The output amplitude of the oscillator is automatically controlled by an ALC loop Q9-Q13 (P/O A8) to provide the injection voltages required by the Q ranges used. The oscillator output is further coupled to a high impedance circuit Q3-Q6 which provides a buffer stage between the oscillator and the RF power amplifier assembly.

4-12. RF POWER AMPLIFIER (A1A2)

4-13. The RF Power Amplifier assembly consists of a cascode amplifier circuit Q1-Q2 with a gain of about 18dB and an impedance converter Q3-Q4. Commonly called a cascode, the circuit uses an emitter grounded amplifier followed by a grounded base stage. The circuit has excellent noise figure, broadband characteristics, and is very stable. The impedance con-

Paragraphs 4-14 to 4-30

verter Q3-Q4 consists of a pair of emitter followers connected in series which provides a higher input impedance and lower output impedance.

4-14. ALC AMPLIFIER(P/O A8)

4-15. The ALC Amplifier circuit Q9-Q13 provides the appropriate correction signal to the Oscillator assembly(A1A1) in order to control the oscillator output in accordance with the fixed reference dc level set by the OSC LEVEL control.

4-16. Q/ Δ Q RANGE ATTENUATOR(A3)

4-17. The Q RANGE Attenuator consists of four switches which provide a total attenuation of 30.4dB. An additional switch is used for the Δ Q measurement. The Meter Scale Indicator(A11) ganged with Q RANGE switches, utilizes four lamps, two of these lamps are used for the Q scale display and the other two for the Δ Q scale. The attenuator output is fed to an Impedance Converter(A4) which consists of transistors Q1 and Q2 and which is similar in operation to the one described in paragraph 4-13.

4-18. TUNING CAPACITOR AND INJECTION TRANSFORMER(A2)

4-19. The Tuning Capacitor sometimes referred to as the Q Capacitor is an important part of the Q Meter. It is the reactance standard in the Q measurement. Because the Q Capacitor can be calibrated precisely, the Q Meter provides direct reading of inductance in addition to Q. To achieve this high accuracy, the capacitor is designed with low loss and low residual inductance. Minimum capacitance is low to maintain accuracy at high frequencies. The Q Capacitor covers a range of 20pF to 475pF. Residual inductance is less than 10nH.

4-20. The Model 4342A uses a new method of injecting a constant voltage through a transformer as shown in Figure 4-3, which has very low output impedance. The transformer has a toroidal core and nearly flat frequency response from 10kHz to 70MHz. The LO terminal consists of a one-turn secondary winding which has an output impedance of approximately 1 milliohm. High measurement accuracy is thus achieved.

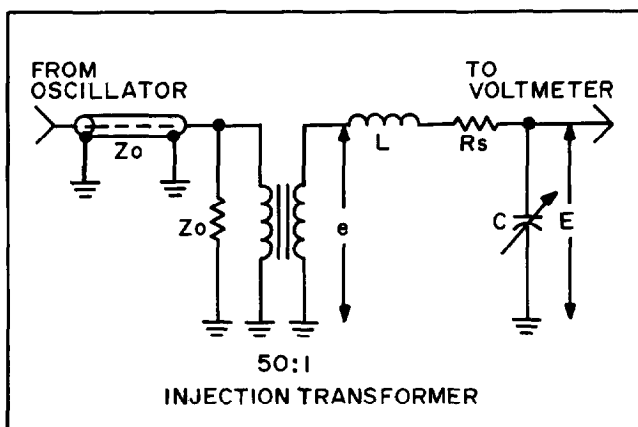

Figure 4-3. Constant Voltage Injection System

4-21. RF AMPLIFIER AND DETECTOR(A5)

4-22. The RF Amplifier and Detector assembly includes the Impedance Converter, the RF Amplifier, and the Detector circuits. The impedance converter Q1-Q4 is a "unity" gain buffer stage amplifier between the Tuning Capacitor assembly A2 and the RF Amplifier Q5-Q9. It provides a high input impedance and a low output impedance similar to what has been described in paragraph 4-13.

4-23. The RF Amplifier circuit Q5-Q9 is a high gain and broad band amplifier. The frequency response of the amplifier is flat and covers the entire spectrum range given in the specifications, while broad band RF transistors supply power gain. The approximate gain is about 34dB. The amplified signal is detected by diodes CR2-CR5 and coupled to the DC Amplifier assembly A6.

4-24. DC AMPLIFIER(A6)

4-25. The DC Amplifier Q1-Q5 provides a gain from 0 to 20dB. It is used to drive linearly the meter. Various gain adjustment, balance control, Δ Q COARSE AND FINE adjustments, METER ZERO ADJUST, and Δ Q function are provided for in this assembly. A Q ANALOG OUTPUT is also supplied which can be interfaced with other instruments. Frequency signals down to and including dc can be handled by the amplifier. By combining direct coupling with a resistive feedback circuit, good stability is obtained.

4-26. Q LIMIT SELECTOR(A7)

4-27. The Q Limit Selector assembly includes a comparator circuit Q1-Q3, a Schmitt trigger Q4-Q5, a monostable multivibrator Q6-Q7 and a driver Q8-Q9. The comparator compares the output of the detected RF signal with the Q LIMIT setting. The comparator output is then coupled via an emitter follower to the Schmitt trigger which generates a fast rise pulse output. This signal is coupled to the monostable multivibrator which has a fixed time constant of 1 second, and also supplies the necessary drive signal to the driver stage. An OVER LIMIT SIGNAL OUTPUT and DISPLAY TIME(1 sec or ∞) are provided.

4-28. CIRCUIT DETAILS

4-29. LC OSCILLATOR(P/O A1A1)

4-30. FREQUENCY RANGE switches select the appropriate LC circuit, setting the operating frequencies of the oscillator Q1-Q2. In the Hartley configuration, when an RF current flows in the tuned circuit, there is a voltage drop across L . The tap on the L coil will be at an intermediate potential with respect to the two ends of the coil. The amplified current in the Q2 collector circuit, which flows through the bottom section of L , is in phase with the current already flowing in the circuit and thus in the proper relationship for positive feedback. The Colpitts arrangement uses the voltage drops across the two capacitors C18 and C19 in series in the tuned circuit to supply the feedback. Other than this, the Colpitts operation is the same as just described for the Hartley configuration.

4-31. IMPEDANCE CONVERTER(P/O A1A1) AND RF POWER AMPLIFIER(A1A2)

4-32. FET Q3 provides a high input impedance for the impedance Converter circuit. Transistor Q5 is used as a current source and Q4 provides positive feedback to make Q3 gain equal to unity. Emitter follower Q6 provides low impedance output signals to the RF Amplifier stage. Inductor L8 acts as a parasitic oscillation suppressor and C30 is a dc blocking capacitor. The signal from the Impedance Converter is ac coupled to RF Power Amplifier Q2 via C2. Transistors Q1 and Q2 form a cascode stage as previously described in paragraph 4-12. Resistor R11 and C6 form a frequency compensation network and C5 is a bypass capacitor. Transistors Q3 and Q4 form an Impedance Converter as described in paragraph 4-12. Inductor L1 and L4 are parasitic oscillation suppressors.

4-33. ALC AMPLIFIER(P/O A8)

4-34. Transistor Q9 thru Q13 form the ALC Amplifier assembly. FET Q9A and Q9B form a differential amplifier with Q11 as its current source. A portion of the rectified RF Amplifier signal is taken across diode A3CR1 and coupled to FET Q9B. Transistors Q10 and Q12 form another differential amplifier with Q13 as its current source. The drain output signal of FET Q9B turns on transistor Q12. The current flowing through the collectors of transistors A1A1Q1 and A1A1Q2 is caused to vary by the setting of the OSC LEVEL control R26. This variation in A1A1Q1 collector current causes a change in the tuned circuit current and the gain of the Oscillator is thereby controlled. C10 provides ac feedback and circuit stabilization.

4-35. Q RANGE ATTENUATOR(A3)

4-36. The Q Range Attenuator with a total attenuation of 30.4dB covers the entire frequency range. The following steps of 10.4dB, 9.6dB, and 10.4dB are provided to correlate the meter reading with the Q Ranges used in the proper ratio (ie. 30/3, 100/10, etc.). The maximum insertion loss is 0.1dB and the impedance is 50Ω nominal. The Q Attenuator output is coupled to Impedance Converter A4 which is arranged in a Darlington pair configuration.

4-37. IMPEDANCE CONVERTER, RF AMPLIFIER AND DETECTOR(A5)

4-38. The Impedance Converter Q1-Q4 is identical in operation to the description given in paragraph 4-32. Diode CR1 protects Q4 from initial current surge. Transistors Q5-Q9 provide RF amplification for the broad band RF frequencies with a total gain of approximate 34dB. Variable resistor R32 and variable capacitor C16 provide for the adjustment of medium and high frequency response of the amplifier respectively. A flat response is obtained throughout the entire frequency band. The signal is ac coupled to detector diode CR2 via C19. Capacitor C20 provides filtering action. Diodes CR3 thru CR5 in conjunction with R42 and R43 cancel the non-linearities of diode CR2. A linear reading is provided to the meter circuit.

4-39. DC AMPLIFIER(A6)

4-40. FET Q1 supplies Q ANALOG OUTPUT proportional to the meter deflection to J1 connector. Variable resistors R4 and R6 are used for the settings of the Q ANALOG OUTPUT-BALANCE and GAIN respectively. FET Q2A and Q2B form a differential amplifier with transistor Q4 as a current source. Diode CR1 compensates for temperature changes. Q3 and Q5 supply current drive to the meter. Resistors R2 and R21 provide for X1 GAIN and X10 GAIN adjustments respectively. Zener diode CR2 and CR3 are used to regulate for the +25V and -25V supplies, inductors L1, L2 and capacitors C2, C3 are used to obtain additional filtering of meter circuit supply voltages. Resistor R2 (mounted on chassis) provides for METER ZERO adjustment. Resistors R3 and R4 (mounted on chassis) are used for the ΔQ ZERO FINE and COARSE adjustments respectively.

4-41. Q LIMIT SELECTOR(A7)

4-42. High impedance FETs Q1 and Q2 form a comparator circuit. Emitter follower Q3 dc couples the comparator output to the Schmitt trigger Q4 and Q5. Capacitor C2 is used as a negative feedback path to reduce the ripple voltage at Q3 emitter. Transistors Q4 and Q5 provide Schmitt trigger action. When Q4 base voltage reaches 9V, the transistor will turn on and Q5 which is normally on will turn off. A positive going pulse will be generated and coupled via capacitor C3 and diode CR3 to the one-shot multivibrator Q6 and Q7. Normally, transistor Q7 is on and Q6 is cut off by the voltage drop across the common bias resistor R19. The pulse from Q5 turns on Q6 which in turn switches off Q7 for one second. Capacitor C6, resistors R20, R21, and R22 determine the constant of the circuit. Transistor Q8 turned on by the rise in Q7 collector voltage operates K1 the OVER LIMIT DISPLAY relay. Transistor Q9 (normally on) is used for ∞ OVER LIMIT DISPLAY TIME. Diodes CR5 and CR6 protect Q8 and Q9 against initial line transient when the instrument is turned on.

4-43. POWER SUPPLY(P/O A8)

4-44. Description of the Power Supply operation will pertain to the +25 volt supply. For the negative supply, operation will be identical but with reversed polarities. Rectifiers CR1 thru CR4 form a fullwave bridge rectifier for the +25 volt supply. In this arrangement two rectifiers operate in series on each half of the cycle, one rectifier being in the lead to the load; the other being in the return lead.

4-45. Pulsating (rectified) dc at the output of the four-diode rectifier bridge is applied to the collector of the series regulator Q1. Closely matched transistors Q2, Q5 and Q3, Q4 form differential amplifier with high common mode signal rejection. The output voltage is applied across R11, R12, and R13 a voltage divider, such that some fraction of this voltage will be applied to the base of Q5. Should the voltage at the base of Q5 increase, its collector will go more negative. This negative going signal will be applied through emitter follower Q4 and cause Q3 collector to go negative. The negative going signal from Q3 is coupled through emitter follower Q1 and series regulator Q1 (mounted on chassis). Subsequently the signal

at the base of Q1 will increase the effective resistance of series regulator.

4-46. The rectifier output is continually changing, as it is a pulsating current. Thus the amplifier chain feeding the series regulator is continually compensating for this pulsation, effectively smoothing the rectifiers output. Capacitor C2 (mounted on chassis) sets ac output impedance. Zenor diode CR5 provides constant base voltage to Q2. Diode CR6 protects transistor Q3 against transients. Diodes CR7, CR8, and CR9 provide current limiting in the event of a grounded output. As stated earlier the operation for the negative supply is identical to the positive supply, except that only one differential amplifier is used in the circuit.

Table 5-1. Recommended Test Equipment.

Instrument Type	Required Performance	Recommended Model
AC Voltmeter	Frequency Range: 10kHz to 1MHz Voltage Range: 1mV to 1V Accuracy: 1% at 200kHz.	HP 400E
RF Voltmeter	Frequency Range: 500kHz to 100MHz Voltage Range: 10mV to 1V Frequency Flatness: $\pm 1\%$	HP 3406A (with known frequency flatness)
Digital Voltmeter	Voltage Range: 0.1V to 100V dc DC Voltage Accuracy: 0.1% of reading AC Frequency Range: ≤ 100 kHz AC Voltage Accuracy: 1% of reading	HP 3456A
Frequency Counter	Frequency Range: 10kHz to 80MHz Sensitivity: 50mV	HP 5381A
Test Oscillator	Frequency Range: 10kHz to 100kHz Output Voltage: 1.0V max. Distortion: less than 1%.	HP 651B
RF Oscillator	Frequency Range: 100kHz to 70MHz Output: 1.0V max.	HP 8601A
Oscilloscope	Bandwidth: 50MHz Sensitivity: 5mV/cm Input Impedance: $1M\Omega$	HP 180C with 1801A and 1821A Plug-ins
Impedance Meter	Frequency: 100kHz Full Scale Range: 500pF Accuracy: 0.3%	HP 4192A
Reference Inductor	Frequency Range: 110kHz to 300kHz Q: higher than 100	HP 16475A
50 Ω Resistor	Metal Film 0.5% 1/4W	HP P/N 0698-5965

SECTION V MAINTENANCE

5-1. INTRODUCTION.

5-2. This section provides the instructions and information required to maintain the HP Model 4342A Q Meter. Included are Performance Checks, Adjustment and Calibration Procedures, Servicing and Troubleshooting guides.

5-3. TEST EQUIPMENT REQUIRED.

5-4. The equipment required to maintain the Model 4342A are listed in Table 5-1. The table lists the type of equipment to be used, the performance requirements and recommended model. If the recommended model is not available, equipment which meets or exceeds the critical performance may be substituted.

5-5. Q ACCURACY CONSIDERATIONS.

5-6. A Q Meter theoretically measures the comprehensive Q of a circuit. In practice, residual circuit parameters, which do not exist in ideal circuits, contribute to measured Q values. Insertion resistance, residual inductance in series with the COIL terminals,

Q voltmeter input conductance, and tuning capacitor loss are some of the factors that contribute to measurement errors in the practical measurement of Q in a typical circuit.

These errors can be minimized by the use of a low output impedance injection transformer system, a low loss tuning capacitor, and a Q voltmeter which has a low input conductance, as in the Model 4342A. Consequently, the 4342A will indicate higher Q values than other currently available Q meters.

By assuming that no internal circuit loss exists in the Q Meter, the specified Q accuracy can be guaranteed by performing the adjustment and calibration procedures in this section. If a Q calibration, which takes the actual internal loss of the instrument into account is required, a Q value reading check with Q standards (inductors) should be done in addition to the adjustment and calibration procedures described in paragraphs 5-9 and those which follow.

At the present time, no Q standards are available for users, thus a Q accuracy check with Q standards can not be performed at the facility where the instrument is used. Since, Hewlett-Packard, however, maintains Q standards traceable to NBS (National Bureau of Standards) in its major service offices, a calibration service with authorized Q standards for the 4342A is always available. If a Q accuracy check is needed, contact your nearest Hewlett-Packard office. If HP Models 513A/518A Q standards are owned and maintained, a Q accuracy check for the 4342A can be done at the user's location. Refer to Table 5-2 for Q Correction Factors.

Table 5-2. Q Correlation Factors.

Q Standard	Frequency	Correlation Factor*
518-A5	50 kHz	1.04
	100 kHz	1.07
	150 kHz	1.13
518-A4	150 kHz	1.05
	300 kHz	1.08
	450 kHz	1.12
513-A	500 kHz	1.01
	1 MHz	1.04
	1.5MHz	1.12
518-A3	1.5MHz	1.05
	3 MHz	1.03
	4.5MHz	1.05
518-A2	5 MHz	1.07
	10 MHz	1.09
	15 MHz	1.23
518-A1	15 MHz	1.27
	30 MHz	1.17
	45 MHz	1.37

* Correlation Factor x Indicated Q - Value on 513/518 = 4342A Indicated Q-Value.

5-7. OPTION.

5-8. The calibration and adjustment procedures for Option 001 instruments (that differ from the standard Model 4342A) are provided in paragraphs 5-25 and below.

Table 5-3. Frequency Accuracy Check.

Frequency Range	Frequency Dial Setting	Measured Accuracy	Counter Reading
22k - 70k	2.2	±1.5%	21.670 - 22.330 kHz
	L	±1.0%	24.922 - 25.424 kHz
	5.0	±1.5%	49.250 - 50.750 kHz
	7.0	±1.5%	68.950 - 71.050 kHz
70k - 220k	7.0	±1.5%	68.950 - 71.050 kHz
	L	±1.0%	78.822 - 80.413 kHz
	15	±1.5%	147.75 - 152.25 kHz
	22	±1.5%	216.70 - 223.30 kHz
220k - 700k	2.2	±1.5%	216.70 - 223.30 kHz
	L	±1.0%	249.22 - 254.24 kHz
	5.0	±1.5%	492.50 - 507.50 kHz
	7.0	±1.5%	689.50 - 710.50 kHz
700k - 2.2M	7.0	±1.5%	689.50 - 710.50 kHz
	L	±1.0%	788.22 - 804.13 kHz
	15	±1.5%	1477.5 - 1522.5 kHz
	22	±1.5%	2167.0 - 2233.0 kHz
2.2M - 7M	2.2	±1.5%	2167.0 - 2233.0 kHz
	L	±1.0%	2492.2 - 2542.4 kHz
	5.0	±1.5%	4925.0 - 5075.0 kHz
	7.0	±1.5%	6895.0 - 7105.0 kHz
7M - 22M	7.0	±1.5%	6895.0 - 7105.0 kHz
	L	±1.0%	7882.2 - 8041.3 kHz
	15	±1.5%	14.775 - 15.225 MHz
	22	±1.5%	21.670 - 22.330 MHz
22M - 70M	2.2	±2.0%	21.560 - 22.440 MHz
	L	±1.0%	24.922 - 25.424 MHz
	5.0	±2.0%	49.000 - 51.000 MHz
	7.0	±2.0%	68.600 - 71.400 MHz

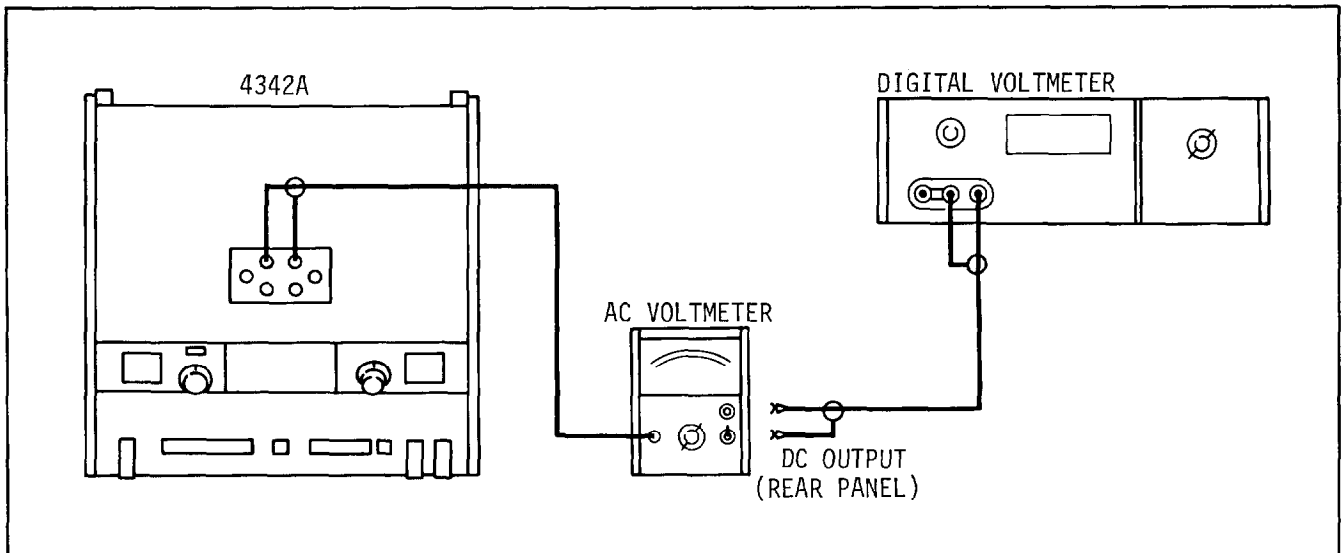

Figure 5-1. Q Range Check.

5-9. PERFORMANCE CHECKS.

5-10. The Performance Checks compare the 4342A instrument with its specifications. These checks are used in incoming inspection, periodic maintenance, and after a repair. Before beginning the Performance Checks, do mechanical and electrical meter zero adjustments using the procedure in Figure 3-6.

5-11. FREQUENCY ACCURACY CHECK.

An electronic frequency counter is required for this check.

- a. Connect frequency counter to 4342A rear panel FREQUENCY MONITOR connector.
- b. Set 4342A controls as follows:
 FREQUENCY RANGE 22k to 70k
 FREQUENCY dial 2.2
 Other controls any settings
- c. Frequency counter reading should be within 21,678kHz to 22,320kHz.
- d. Check frequency at each frequency setting in accord with Table 5-3. Counter readings should be within the tolerance limits given in Table 5-3.

5-12. Q RANGE CHECK.

An AC Voltmeter and a Digital Voltmeter are required for this check.

- a. Connect an AC Voltmeter to 4342A LO and GND terminals as shown in Figure 5-1. Connect Digital Voltmeter to AC Voltmeter dc output terminals.
- b. Set 4342A controls as follows:
 FREQUENCY RANGE 70k - 220k
 FREQUENCY dial 20
 Q RANGE 30
 Q LIMIT CW
 L/C dial 25(pF)
 ΔC dial 0
- c. Set AC Voltmeter range to 30mV and Digital Voltmeter to 1V. Digital Voltmeter reading should be between 920.6 and 977.4mV.
- d. Set Q RANGE and AC Voltmeter range in accord with Table 5-4. Digital Voltmeter reading should be within the tolerance limits given in Table 5-4.

Table 5-4. Q Range Check.

Q Range	AC Voltmeter Range	Digital Voltmeter Reading
30	30 mV	920.6 - 977.4 mV
100	10 mV	873.0 - 927.0 mV
300	3 mV	920.6 - 977.4 mV
1000	1 mV	873.0 - 927.0 mV

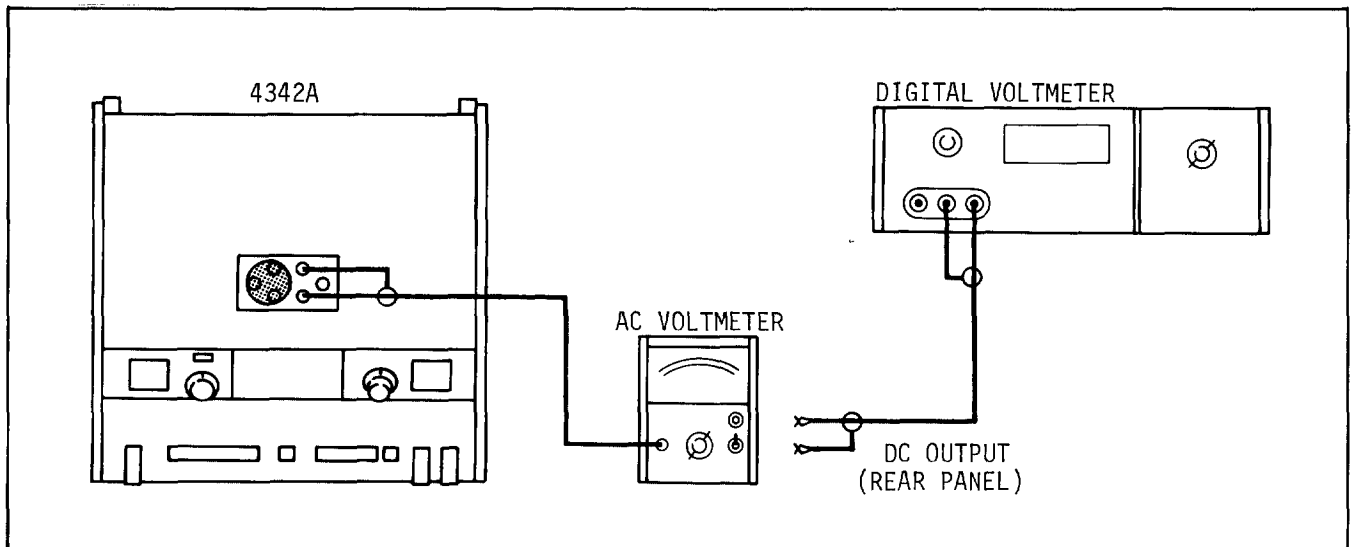

Figure 5-2. ΔQ Range Check.

5-13. ΔQ RANGE CHECK.

An AC Voltmeter, a Digital Voltmeter, and a Reference Inductor are required for this check.

- a. Connect the AC Voltmeter to 4342A HI and GND terminals and place the Reference Inductor in the HI and LO terminals as shown in Figure 5-2. Monitor DC voltage at AC Voltmeter dc output terminals with Digital Voltmeter.
- b. Set 4342A controls as follows:
 FREQUENCY RANGE 70k - 220k
 FREQUENCY dial 20
 Q RANGE 100
 Q LIMIT CW
 L/C dial 25(pF)
 ΔC dial 0
- c. Set AC Voltmeter range to 1V.
- d. Adjust L/C dial so that 4342A meter pointer indicates 100 (need not indicate a peak value). Adjust to exactly 100 with the ΔC dial.
- e. Digital Voltmeter reading should be within 873mV to 927mV.
- f. Adjust L/C dial for 900.0mV on Digital Voltmeter display. Use ΔC dial for accurate adjustment.

- g. Set Q/ ΔQ RANGE to $\Delta Q10$ and adjust ΔQ ZERO control (coarse and fine) so that Q meter indicates 0 (full scale) on ΔQ scale.
- h. Adjust ΔC dial so that Q meter indicates 10 on ΔQ scale and note Digital Voltmeter reading. It should be within 801.9mV to 818.1mV.

5-14. CAPACITANCE ACCURACY CHECK.

An Impedance Meter is required for this check.

- a. Connect Impedance Meter to 4342A HI and GND terminals as shown in Figure 5-3.

Note

When the Model 4192A is used for this check, set panel controls as follows:

- DISPLAY A C
- ZY RANGE AUTO
- CIRCUIT MODE AUTO
- FREQUENCY 100kHz
- OSC LEVEL 1V
- CABLE LENGTH 1m

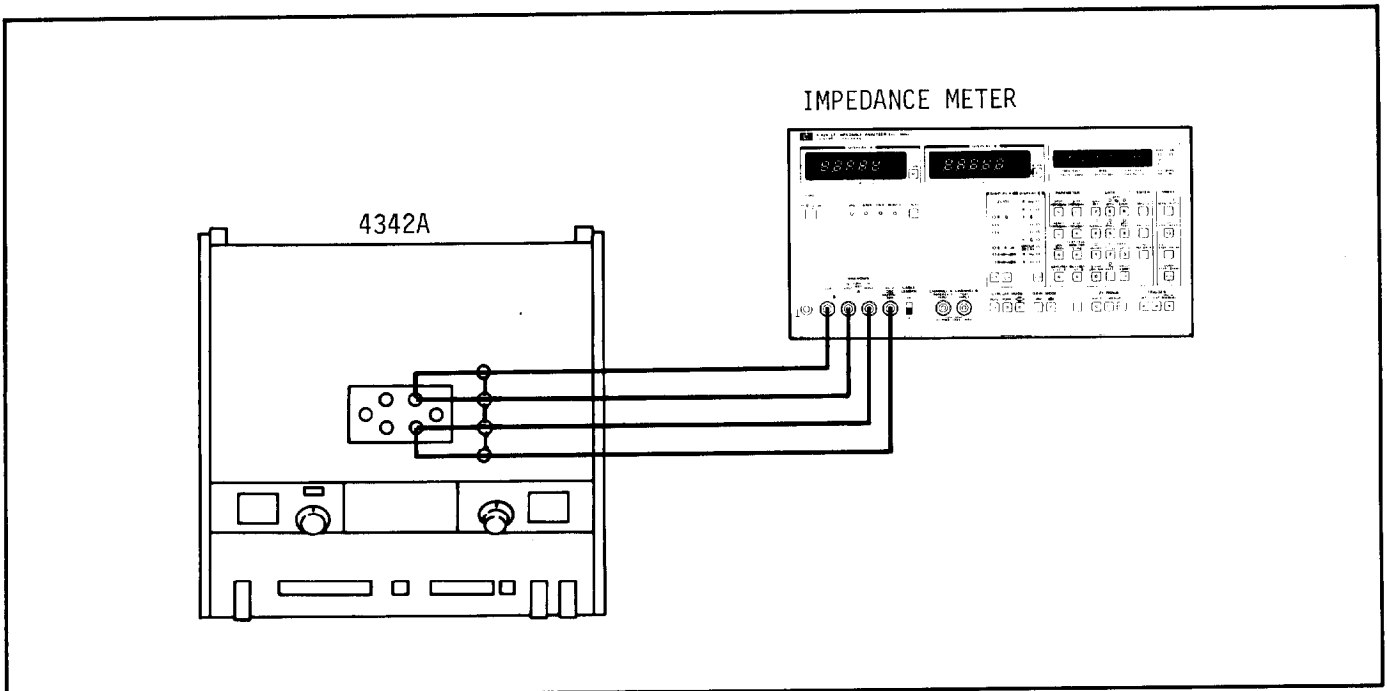

Figure 5-3. Capacitance Accuracy Check.

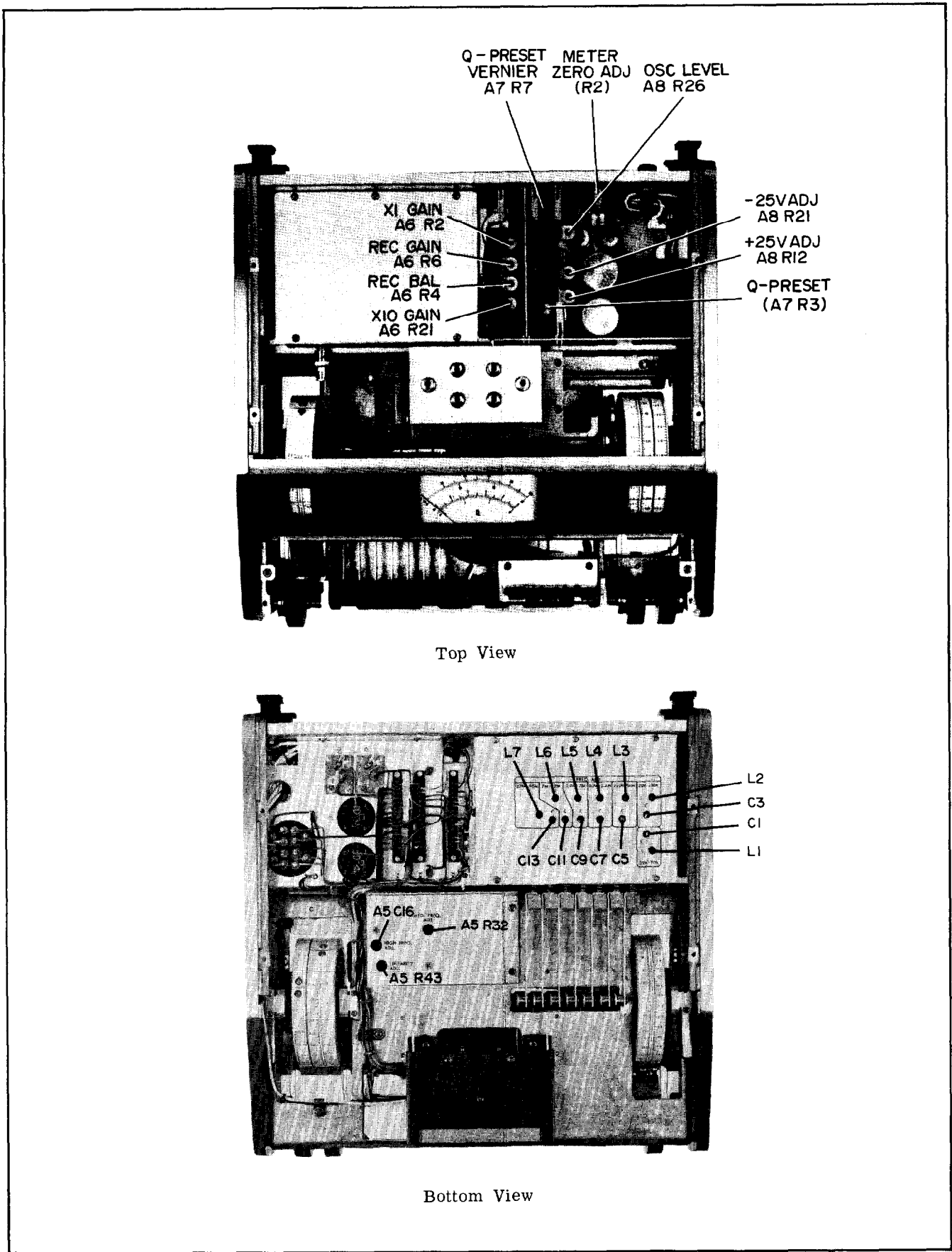

Figure 5-4. Model 4342A Adjustment Locations.

b. Set 4342A controls as follows:

L/C dial 25(pF)
 ΔC dial 0
 Other controls any settings

c. Capacitance Bridge reading should be between 23.9 and 26.1pF.

d. Check capacitance on each L/C dial and ΔC dial setting in accord with Table 5-5. Capacitance Bridge readings should be within the specified tolerance limits given in Table 5-5.

Table 5-5. Capacitance Accuracy Check.

C Dial	ΔC Dial	C-Bridge Reading
25	0	23.9 - 26.1
25	-5	(0 Reading)* - 5±0.1
25	+5	(0 Reading)* + 5±0.1
100	0	98.9 - 101.1
200	0	197.9 - 202.1
300	0	296.9 - 303.1
400	0	395.9 - 404.1
470	0	465.2 - 474.8
470	+5	(0 Reading)* + 5±0.1

* Note: 0 Reading is the readout on the Capacitance Bridge when ΔC Dial is set to 0.

5-15. Q LIMIT OPERATION CHECK.

A Reference Inductor is required for this check.

a. Connect a Reference Inductor to 4342A HI and LO terminals.

b. Set 4342A controls as follows:

FREQUENCY RANGE 70k - 220k
 FREQUENCY dial 20
 Q RANGE 100
 Q LIMIT CW
 L/C dial 25(pF)
 ΔC dial 0

c. Set OVER LIMIT DISPLAY TIME switch on 4342A rear panel to ∞ position.

d. Rotate L/C dial until Q meter pointer deflection exceeds full scale and scales out.

e. Set Q LIMIT control dial to 60. OVER LIMIT lamp should light.

f. Adjust L/C dial so that Q meter pointer indicates approximately 50. OVER LIMIT lamp should be extinguished.

g. Rotate L/C dial so that Q meter indication increases slowly as it approaches 60. The OVER LIMIT lamp should light at or near a Q meter indication of 60.

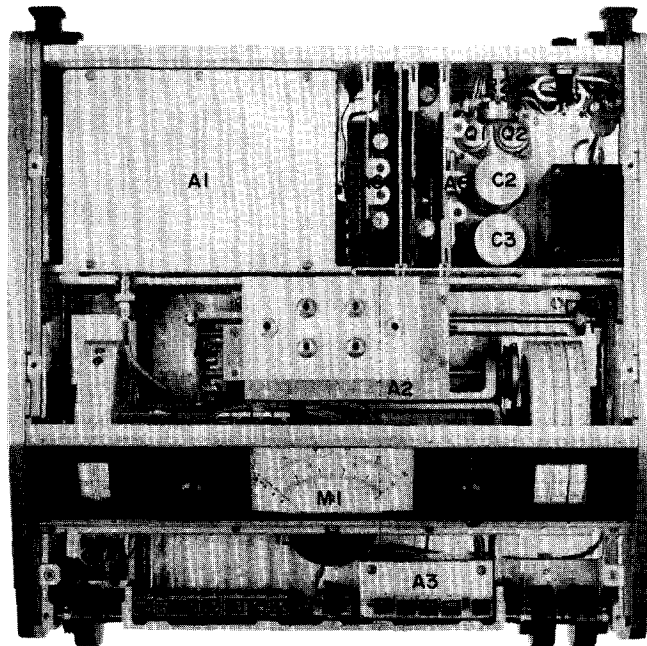

Top View

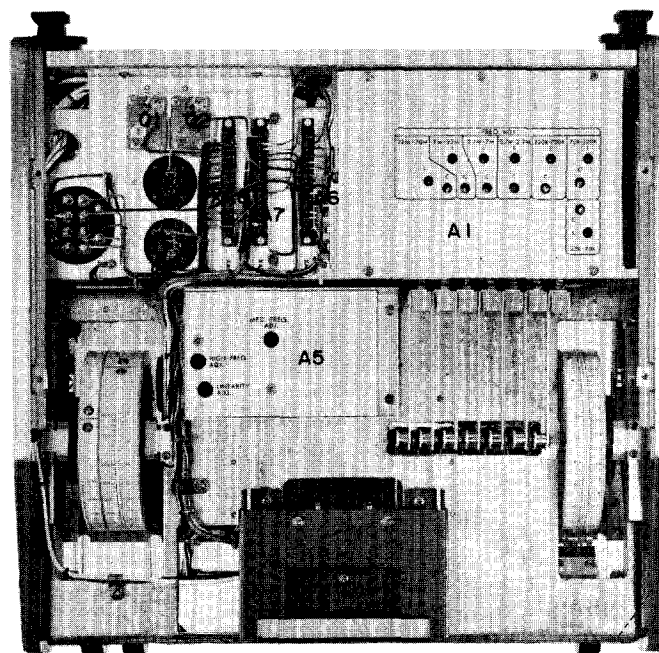

Bottom View

Figure 5-5. Model 4342A Assembly Locations.

Table 5-6. Adjustable Components.

Reference Designator	Name of Control	Purpose
A1A1C1, -C3, -C5, -C7, -C9, -C11, -C13	FREQ. ADJ C	To adjust oscillator frequency of upper range limits of individual frequency ranges to maximize frequency accuracies.
A1A1L1 thru A1A1L7	FREQ. ADJ L	To adjust oscillator frequency of lower range limits of individual frequency ranges to maximize frequency accuracies.
A5C16	HIGH FREQ. ADJ	To adjust Q meter sensitivity in high frequency (70MHz) region to obtain optimum frequency flatness.
A5R32	MED FREQ. ADJ	To adjust Q meter sensitivity in high frequency (20MHz) region to obtain optimum frequency flatness.
A5R43	LINEARITY ADJ	To adjust Q meter linearity to maximize measurement accuracy.
A6R2	X1 GAIN	To set Q meter full scale sensitivity to maximize measurement accuracy.
A6R4	REC BAL	To set Q ANALOG OUTPUT dc voltage at rear panel to zero volts at Q meter zero scale deflection.
A6R6	REC GAIN	To set Q ANALOG OUTPUT dc voltage at rear panel (to 1 volt) at Q meter full scale deflection.
A6R21	X10 GAIN	To adjust ΔQ measurement full scale sensitivity to maximize ΔQ measurement accuracy.
A7R3	Q-PRESET	To properly set Q limit selector sensitivity at Q LIMIT dial full scale setting to maximize the dial scale accuracy.
A7R7	Q-PRESET VERNIER	To properly set Q limit selector sensitivity at Q LIMIT dial center scale setting to maximize the dial scale accuracy.
A8R12 -R21	+25V ADJ -25V ADJ	To set +25V and -25V output voltages of dc power supply.
A8R26	OSC LEVEL	To adjust oscillator output voltage to maximize measurement accuracy.

5-16. ADJUSTMENT AND CALIBRATION PROCEDURES.

5-17. These paragraphs describe complete adjustment and calibration procedures for the Model 4342A. The procedures should be performed when any performance test fails or when it is known that the instrument does not meet the specifications or may be necessary after certain repairs. Table 5-6 is a summary of the purpose of each adjustment and its effect on instrument performance. Adjustment and assembly locations are shown in Figure 5-4 and 5-5, respectively.

WARNING

ADJUSTMENTS DESCRIBED IN THIS SECTION ARE ALLOWED FOR QUALIFIED TECHNICAL PERSONNEL ONLY.

WARNING

ADJUSTMENTS DESCRIBED HEREIN ARE PERFORMED WITH POWER SUPPLIED TO THE INSTRUMENT AFTER PROTECTIVE COVERS HAVE BEEN REMOVED. ENERGY EXISTING AT MANY POINTS MAY, IF CONTACTED, RESULT IN PERSONAL INJURY.

Preparatory to beginning adjustments, remove top cover by removing the four retaining screws near side frames (both sides). Remove bottom cover with similar procedure.

5-18. POWER SUPPLY ADJUSTMENT.

A DC Voltmeter (or a DMM) is required for this adjustment.

- a. Turn 4342A power off. Take out A8 Power Supply Assembly. Reinstall it with an extender board.
- b. Turn instrument on. Connect DC Voltmeter plus input lead to plus terminal of capacitor A8C3 and minus input lead of voltmeter to chassis.
- c. Adjust A8R12 (+25V ADJ) for a reading of +25 \pm 0.025V on DC Voltmeter.
- d. Connect DC Voltmeter minus input lead to minus terminal of capacitor A8C6 and plus input lead of voltmeter to chassis.

- e. Adjust A8R21 (-25V ADJ) for a reading of -25V \pm 0.025V on DC Voltmeter.

Note

Voltage ripple should be less than 0.35mVrms for both +25V and -25V power supplies.

5-19. OSCILLATOR LEVEL ADJUSTMENT.

An AC Voltmeter and a Digital Voltmeter are required for this adjustment.

- a. Connect AC Voltmeter to 4342A LO and GND terminals as shown in Figure 5-1. Monitor dc voltage at AC Voltmeter dc output terminals with Digital Voltmeter.
- b. Set 4342A controls as follows:
FREQUENCY RANGE 22k - 70k
FREQUENCY dial 5.0
Q RANGE 30
Q LIMIT CW
L/C dial 25(pF)
 Δ C dial 0
- c. Set AC Voltmeter range to 30mV and Digital Voltmeter range to 1V.
- d. Adjust A8R26 (OSC LEVEL adj.) for 949.0mV \pm 5mV on Digital Voltmeter display.

5-20. OSCILLATOR FREQUENCY ADJUSTMENT.

A Frequency Counter is required for this adjustment.

- a. Connect a frequency counter to 4342A rear panel FREQUENCY MONITOR connector.
- b. Set 4342A controls as follows:
FREQUENCY RANGE 22k - 70k
FREQUENCY dial 2.2
Other controls any settings
- c. Remove instrument bottom cover and oscillator shield cover labeled with names of FREQ ADJ potentiometers and trimmer capacitors.

- d. Loosen all oscillator coil locking nuts. Replace oscillator shield cover.
- e. Adjust A1A1L1 (see Figure 5-5, instrument bottom view) for 22.000kHz ± 0.330 kHz on frequency counter display.
- f. Set FREQUENCY dial to 7.0.
- g. Adjust A1A1C1 for 70.000kHz ± 1.050 kHz on frequency counter display.
- h. Set FREQUENCY dial to "L" point.
- i. Frequency counter reading should be within 24.922kHz to 25.420kHz. If not, repeat steps b through g.
- j. Check dial tracking throughout the 22 - 70kHz frequency range. A compromise adjustment may improve tracking. Compare with Table 5-3.
- k. Set FREQUENCY RANGE and FREQUENCY dial in accord with Table 5-7 and adjust each individual adjustment control (A1A1L2 through L7, C3, C5, C7, C9, C11 and C13) for correct frequency

with procedures similar to steps b through j.

- 1. Remove oscillator shield cover and carefully tighten all oscillator coil locking nuts. Take care that potentiometer does not rotate with nut. Replace oscillator cover.

- m. Recheck instrument against Table 5-7.

5-21. Q VOLTMETER ADJUSTMENT.

A Test Oscillator and a Digital Volemeter are required for this adjustment.

Note

Before proceeding with this adjustment, check meter mechanical and electrical zero using the procedure given in Figure 3-6.

1) X1 Gain and meter linearity adjustments.

- a. Connect the Test Oscillator and the Digital Volemeter to 4342A as shown in Figure 5-6.

Table 5-7. Frequency Adjustment.

Frequency Range	Frequency Dial Setting	Measured Frequency	Adjustment
22k - 70k	2.2	22.000 ± 0.330 kHz	A1A1L1
	7.0	70.000 ± 1.050 kHz	A1A1C1
	"L"	25.173 ± 0.251 kHz	NONE
220k - 700k	2.2	220.00 ± 3.30 kHz	A1A1L3
	7.0	700.00 ± 10.50 kHz	A1A1C5
	"L"	251.73 ± 2.51 kHz	NONE
2.2M - 7.0M	2.2	2200.0 ± 33.0 kHz	A1A1L5
	7.0	7000.0 ± 105.0 kHz	A1A1C9
	"L"	2517.3 ± 25.1 kHz	NONE
22M - 70M	2.2	22.000 ± 0.440 MHz	A1A1L7
	7.0	70.000 ± 1.400 MHz	A1A1C13
	"L"	25.173 ± 0.251 MHz	NONE
70k - 220k	7.0	70.000 ± 1.050 kHz	A1A1L2
	22	220.00 ± 3.30 kHz	A1A1C3
	"L"	79.618 ± 0.796 kHz	NONE
0.7M - 2.2M	7.0	700.00 ± 10.50 kHz	A1A1L4
	22	2200.0 ± 33.0 kHz	A1A1C7
	"L"	796.18 ± 7.96 kHz	NONE
7.0M - 22M	7.0	7000.0 ± 105.0 kHz	A1A1L6
	22	22.000 ± 0.330 MHz	A1A1C11
	"L"	7961.8 ± 79.6 kHz	NONE

b. Set 4342A controls as follows:

FREQUENCY RANGE 22k - 70k
 FREQUENCY dial 2.2
 L/C dial 25(pF)
 ΔC dial -5

c. Set the Test Oscillator frequency to 100kHz and adjust the signal level until the Digital Voltmeter reads 900.0mV.

d. Adjust A6R2 (X1 GAIN adj.) for full scale Q meter reading.

e. Adjust the Test Oscillator's signal level until the DVM reads 450.0mV.

f. Q meter should indicate exactly 1/2 full scale. If Q meter deflection is insufficient, rotate A5R43 (LINEARITY ADJ) CCW until meter reads correctly. If deflection is excessive, rotate A5-R43 slightly CW.

g. Repeat steps c through f until meter indicates 1/2 full scale within ±0.5/100 full scale (1/2 minor division) in step f.

h. Adjust the Test Oscillator's signal level until the DVM reads 300.0mV.

i. Q meter should indicate within 1/3 full scale ±1/100 of full scale (1 minor division). If not, repeat steps c through f.

2) X10 GAIN adjustment.

j. Adjust the Test Oscillator's signal level until the DVM reads 810.0mV.

k. Depress 4342A ΔQ button and set ΔQ RANGE to 10.

l. Adjust ΔQ ZERO control for 10 (zero scale deflection) on ΔQ scale.

m. Adjust the Test Oscillator's signal level until the DVM reads 900.0mV.

n. Q meter should indicate 0 (full scale) on ΔQ scale. If Q meter reading is not zero, adjust A6R21 (X10 GAIN adj.) for correct reading. Repeat steps j through n because both adjustments interact.

5-22. Q ANALOG OUTPUT ADJUSTMENT.

A Test Oscillator and a Digital Voltmeter are required for this adjustment.

a. Set 4342A controls as follows:

Q RANGE 30
 other controls any settings

b. Connect Digital Voltmeter to 4342A rear panel Q ANALOG OUTPUT connector.

c. Adjust A6R4 (REC BAL adj.) for 0V ±0.01V on Digital Voltmeter display.

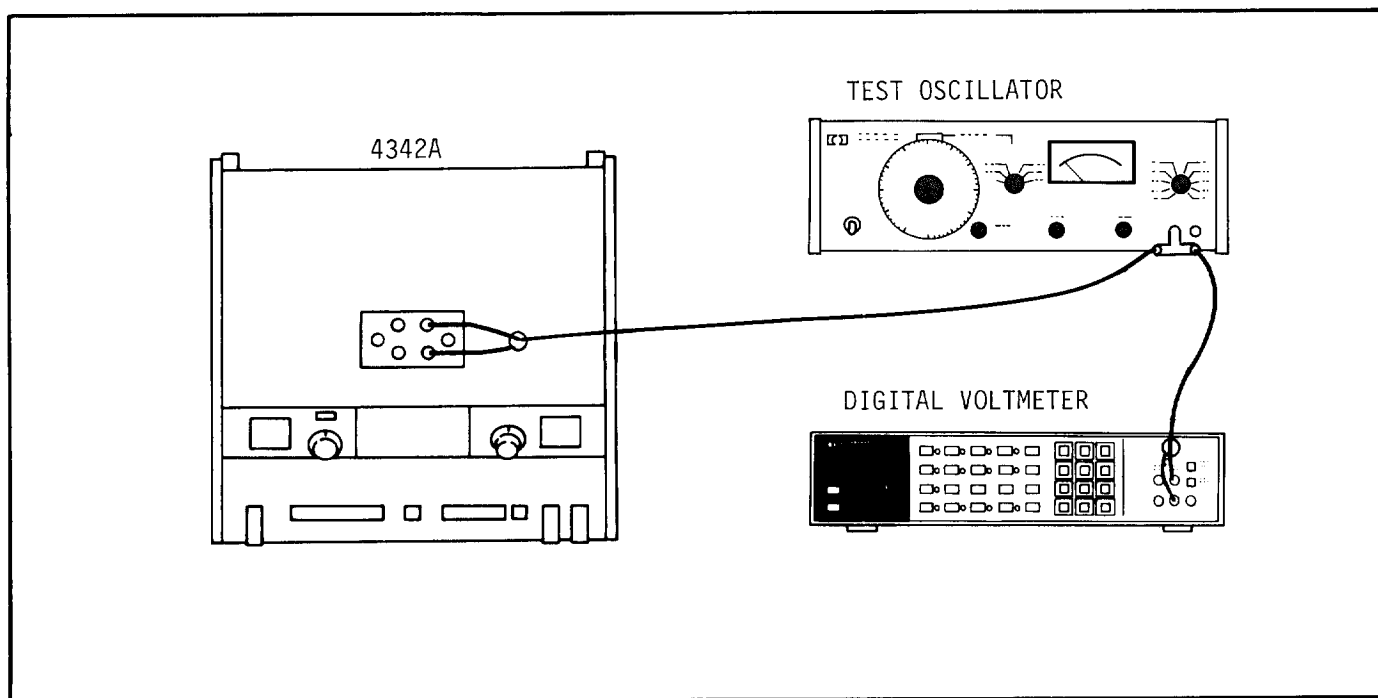

Figure 5-6. Voltmeter Adjustment.

- d. Connect the Test Oscillator to the 4342A as shown in Figure 5-6.
- e. Set the Test Oscillator frequency to 100kHz and output for full scale reading (approx. 900mVrms) on 4342A Q meter.
- f. Adjust A6R6 (REC GAIN adj.) for 1V $\pm 0.01V$ on Digital Voltmeter display.
- g. Repeat steps c through f because both adjustments interact.

- f. Adjust A5R32 (MED. FREQ. ADJ) for full scale reading on 4342A Q meter.
- g. Set RF Oscillator frequency to 70MHz and its output for the same RF Voltmeter reading as that noted in step d.
- h. Adjust A5C16 (HIGH FREQ. ADJ) for full scale reading on 4342A Q meter.
- i. Repeat steps c through h until both difference (from full scale) Q meter readings obtained in steps f and h are within $\pm 2\%$ of full scale.

5-23. FREQUENCY RESPONSE ADJUSTMENT.

An RF Oscillator and an RF Voltmeter (with known frequency flatness) are required for this adjustment.

- a. Connect RF Oscillator and RF Voltmeter as shown in Figure 5-7.
- b. Set 4342A C and ΔC dials to minimum.
- c. Set RF Oscillator frequency to 10MHz and its output for full scale meter deflection (approx. 900mVrms) on 4342A Q meter.
- d. Note RF Voltmeter reading.
- e. Set RF Oscillator frequency to 20MHz and its output for the same RF Voltmeter reading as that noted in step d.

5-24. Q LIMIT SELECTOR ADJUSTMENT.

An RF Oscillator is required for this adjustment.

- a. Set 4342A rear panel OVER LIMIT DISPLAY TIME switch to ∞ position.
- b. Connect RF Oscillator between HI and GND terminals.
- c. Set 4342A Q LIMIT control to 100.
- d. Set RF Oscillator to desired frequency (100kHz to 1MHz) and adjust its output for full scale reading on 4342A Q meter.
- e. Rotate A7R3 (Q-PRESET adj.) CCW until front panel OVER LIMIT indicator lights.

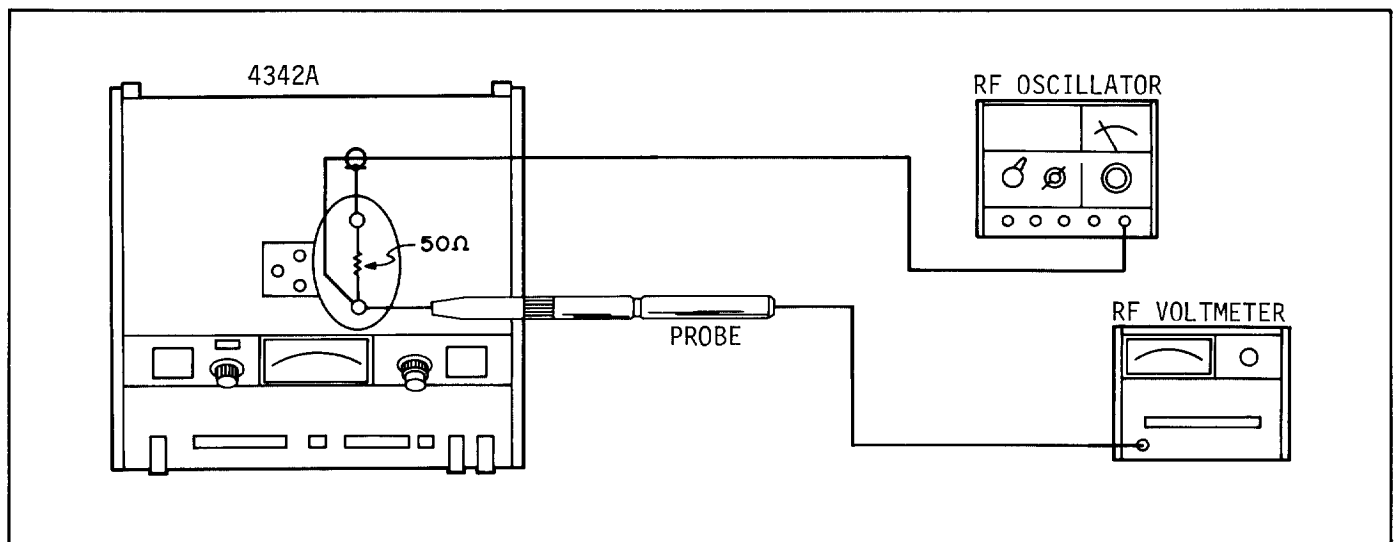

Figure 5-7. Frequency Response Adjustment.

- f. Rotate A7R3 very slowly CW until OVER LIMIT indicator is extinguished.
- g. Set Q LIMIT control to 50. OVER LIMIT indicator should light.
- h. Decrease RF Oscillator output level and note 4342A Q meter reading at which OVER LIMIT indicator just extinguishes. Q Meter reading should be approx. 1/2 full scale (50 ±5 divisions on meter top scale).
- i. If Q Meter reading is low, rotate A7R7 (Q-PRESET VERNIER) slightly CW and repeat steps c through h.
- j. If Q Meter reading is high, rotate A7R7 slightly CCW and repeat steps c through h.

5-25. OPTION 001 MAINTENANCE INSTRUCTIONS.

5-26. This paragraph and those below describe the changes necessary for applying the Performance Checks and Adjustment and Calibration Procedures in this section (V) to Option 001 instruments.

5-27. OPTION 001 PERFORMANCE CHECKS.

5-28. To apply the Performance Check procedure in paragraphs 5-9 and below to option 001 instruments, make the following changes in standard procedures:

- a. Para. 5-11 b. Change the FREQUENCY RANGE and FREQUENCY dial settings to 10k - 32k and 1.0, respectively.

Para. 5-11 c. Change the upper and

Table 5-8. Frequency Accuracy Check (Option 001).

Frequency Range	Frequency Dial Setting	Specified Accuracy	Counter Reading
10k - 32k	1.0	±1.5%	9.8500 - 10.150 kHz
	1.5	±1.5%	14.775 - 15.225 kHz
	L	±1.0%	24.922 - 25.424 kHz
	3.2	±1.5%	31.520 - 32.480 kHz
32k - 100k	3.2	±1.5%	31.520 - 32.480 kHz
	5.0	±1.5%	49.250 - 50.750 kHz
	L	±1.0%	78.822 - 80.413 kHz
	10	±1.5%	98.500 - 101.50 kHz
100k - 320k	1.0	±1.5%	98.500 - 101.50 kHz
	1.5	±1.5%	147.75 - 152.25 kHz
	L	±1.0%	249.22 - 254.24 kHz
	3.2	±1.5%	315.20 - 324.80 kHz
320k - 1M	3.2	±1.5%	315.20 - 324.80 kHz
	5.0	±1.5%	492.50 - 507.50 kHz
	L	±1.0%	788.22 - 804.13 kHz
	10	±1.5%	985.00 - 1015.0 kHz
1M - 3.2M	1.0	±1.5%	985.00 - 1015.0 kHz
	1.5	±1.5%	1477.5 - 1522.5 kHz
	L	±1.0%	2492.2 - 2542.4 kHz
	3.2	±1.5%	3152.0 - 3248.0 kHz
3.2M - 10M	3.2	±1.5%	3152.0 - 3248.0 kHz
	5.0	±1.5%	4925.0 - 5075.0 kHz
	L	±1.0%	7882.2 - 8041.3 kHz
	10	±1.5%	9.8500 - 10.150 MHz
10M - 32M	1.0	±2.0%	9.8000 - 10.200 MHz
	1.5	±2.0%	14.700 - 15.300 MHz
	L	±1.0%	24.922 - 25.424 MHz
	3.2	±2.0%	31.360 - 32.640 MHz

lower frequency limits to 9.850kHz and 10.150kHz, respectively.

Para. 5-11 d. Use Table 5-8 for option 001 instead of Table 5-3.

- b. Para. 5-12 b, 5-13 b, and 5-15 b. Change FREQUENCY RANGE and FREQUENCY dial settings to 100k - 320k and 2.0, respectively.

- b. Para. 5-20 b. Change the FREQUENCY RANGE and FREQUENCY dial settings to 10k - 32k and 1.0, respectively.

Para. 5-20 e. Change frequency tolerance limits to 10.000kHz ± 0.150kHz.

Para. 5-20 f. Change FREQUENCY dial setting to 3.2.

Para. 5-20 g. Change frequency tolerance limits to 32.000kHz ± 0.480kHz.

Para. 5-20 j. Change frequency range to 10 - 32kHz (from 22 - 70kHz).

Para. 5-20k. Use Table 5-9 instead of Table 5-7.

- c. Para. 5-21 b. Change FREQUENCY RANGE and FREQUENCY dial settings to 10k - 32k and 1.0, respectively.

- d. Para. 5-23 g. Change RF Oscillator frequency setting to 32MHz.

5-29. OPTION 001 CALIBRATION AND ADJUSTMENT PROCEDURES.

5-30. To apply the Calibration and Adjustment Procedures in paragraphs 5-16 and those below to option 001 instruments, partially make the following changes in standard procedures:

- a. Para. 5-19 b. Change the FREQUENCY RANGE and FREQUENCY dial settings to 10k - 32k and 2.0, respectively.

Table 5-9. Frequency Adjustment (Option 001).

Frequency Range	Frequency Dial Setting	Measured Frequency	Adjustment
10k - 32k	1.0	10.000 ± 0.150 kHz	A1A1L1
	3.2	32.000 ± 0.480 kHz	A1A1C1
	L	25.173 ± 0.251 kHz	NONE
100k - 320k	1.0	100.00 ± 1.50 kHz	A1A1L3
	3.2	320.00 ± 4.80 kHz	A1A1C5
	L	251.73 ± 2.51 kHz	NONE
1M - 3.2M	1.0	1000.0 ± 15.0 kHz	A1A1L5
	3.2	3200.0 ± 48.0 kHz	A1A1C9
	L	2517.3 ± 25.1 kHz	NONE
10M - 32M	1.0	10.000 ± 0.200 MHz	A1A1L7
	3.2	32.000 ± 0.640 MHz	A1A1C13
	L	25.173 ± 0.251 MHz	NONE
32k - 100k	3.2	32.000 ± 0.480 kHz	A1A1L2
	10	100.00 ± 1.50 kHz	A1A1C3
	L1	79.618 ± 0.796 kHz	NONE
320k - 1M	3.2	320.00 ± 4.80 kHz	A1A1L4
	10	1000.0 ± 15.0 kHz	A1A1C7
	L	796.18 ± 7.96 kHz	NONE
3.2M - 10M	3.2	3200.0 ± 48.0 kHz	A1A1L6
	10	10.000 ± 0.150 MHz	A1A1C11
	L	7961.8 ± 79.6 kHz	NONE

5-31. DIAL RE-STRINGING INSTRUCTIONS.

5-32. This paragraph explains how to re-string and set the dial drive strings which move FREQUENCY, L/C, and C dials which rotate the internal variable capacitors. To maintain dial scale accuracy and smooth dial operation, the dial string must be correctly wound on and attached to the drum scale pulley and dial or capacitor pulley and its tension set properly. If a dial string is off or loose, repair the string in accord with the following instructions which outline the procedures for correctly interlocking dial and capacitor.

5-33. For access to internal dial interlocking mechanism, remove control panel, top, bottom, and side covers, and side frames as follows:

- a. Turn instrument off and remove power cord.
- b. Unscrew the four retaining screws and remove top cover. Remove bottom cover with like procedure.
- c. Remove the four retaining screws located at the left and right (top and bottom) sides of the control panel.
- d. Lift control panel front edge up and remove the panel.
- e. Remove both side panels by removing the four screws on each side.
- f. Remove both side-casting-frames by removing the eight screws on each side.

5-34. FREQUENCY DIAL.

The parts required for stringing frequency dial are:

- | | |
|----------------|------------------------|
| 1) String I: | HP Part No. 04342-8541 |
| 2) String II: | HP Part No. 04342-8542 |
| 3) Belt: | HP Part No. 04342-1051 |
| 4) Screws (2): | HP Part No. 0520-0127 |

Frequency dial re-stringing procedure is illustrated in Figure 5-8.

5-35. L/C DIAL.

To re-string tuning capacitor dial, the following parts are required:

- | | |
|----------------|------------------------|
| 1) String I: | HP Part No. 04342-8541 |
| 2) String II: | HP Part No. 04342-8544 |
| 3) Belt: | HP Part No. 04342-1052 |
| 4) Screws (2): | HP Part No. 0520-0127 |

L/C dial re-stringing procedure is illustrated in Figure 5-9.

5-36. ΔC DIAL.

To re-string ΔC dial, the following parts are required:

- | | |
|----------------|------------------------|
| 1) String I: | HP Part No. 04342-8541 |
| 2) String II: | HP Part No. 04342-8543 |
| 3) Belt: | HP Part No. 04342-1053 |
| 4) Screws (2): | HP Part No. 0520-0127 |

ΔC dial re-stringing procedure is illustrated in Figure 5-10.

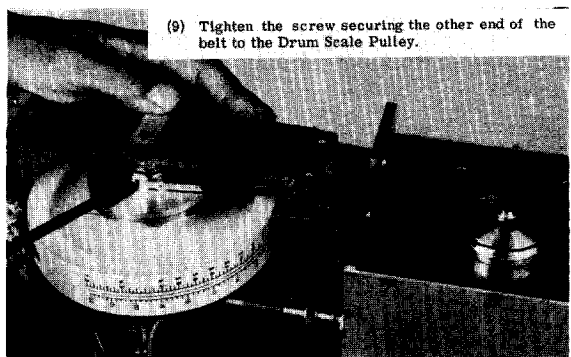
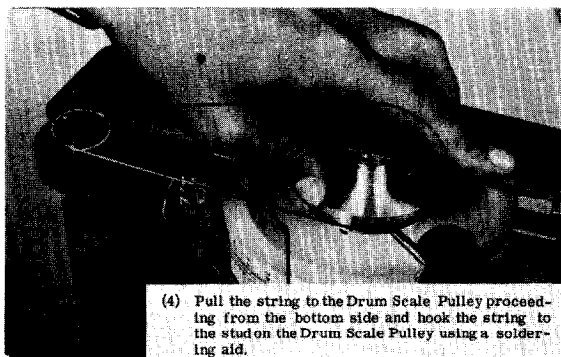
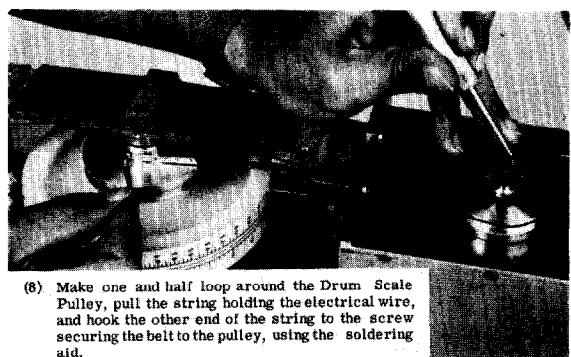
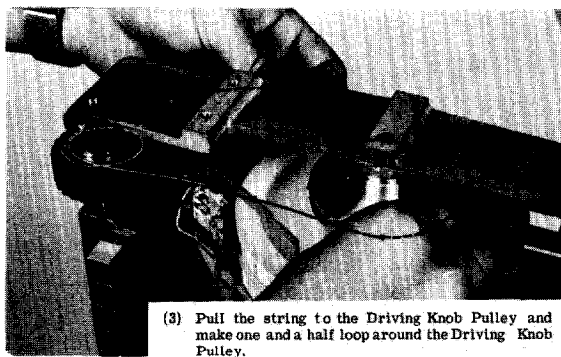
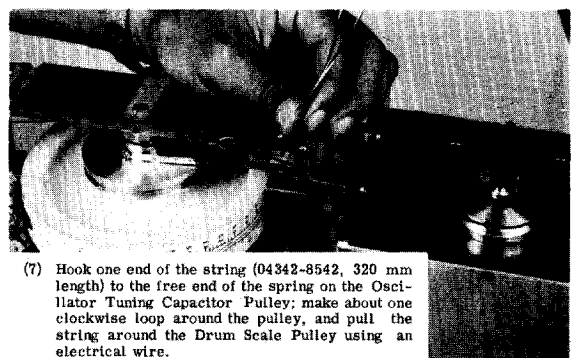
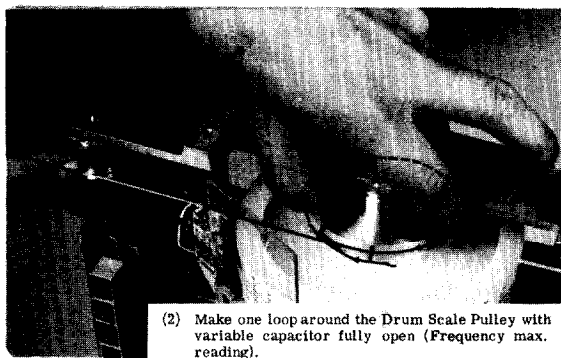
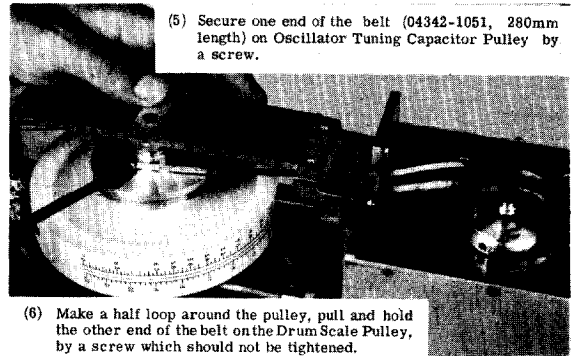
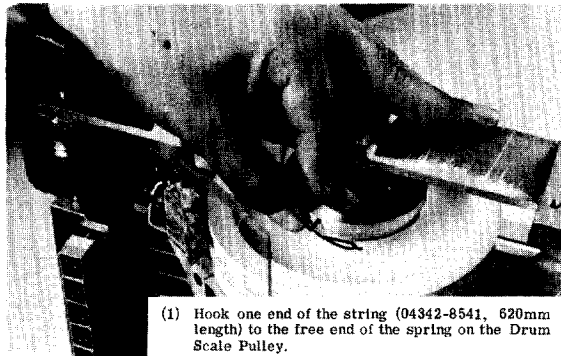
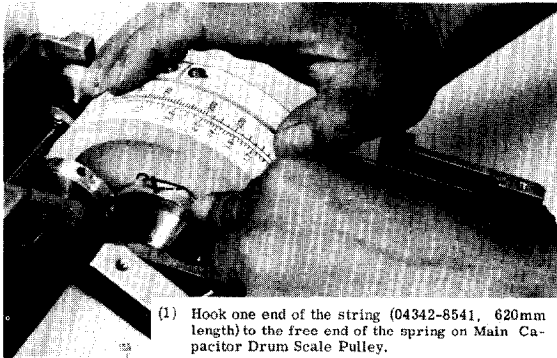
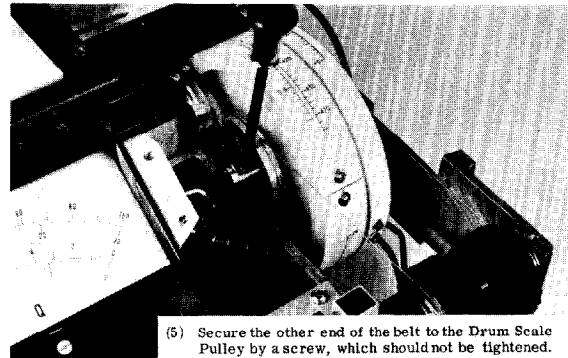

Figure 5-8. Frequency Dial Restringing.



(1) Hook one end of the string (04342-8541, 620mm length) to the free end of the spring on Main Capacitor Drum Scale Pulley.



(5) Secure the other end of the belt to the Drum Scale Pulley by a screw, which should not be tightened.

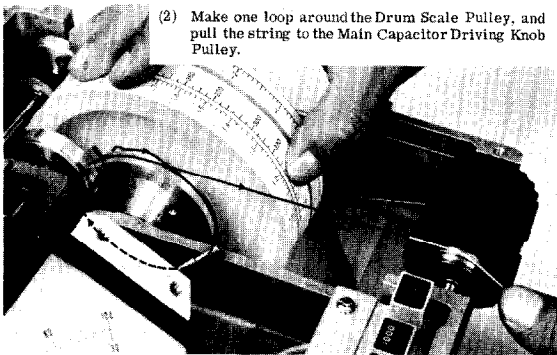

(2) Make one loop around the Drum Scale Pulley, and pull the string to the Main Capacitor Driving Knob Pulley.

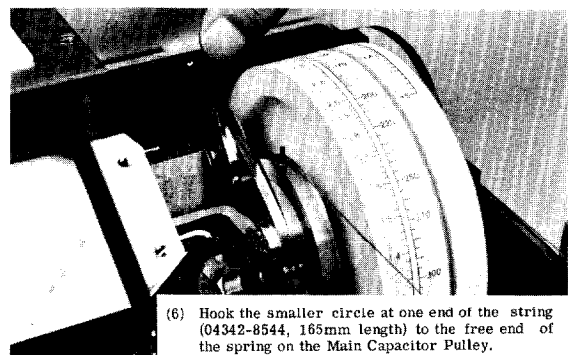

(6) Hook the smaller circle at one end of the string (04342-8544, 165mm length) to the free end of the spring on the Main Capacitor Pulley.

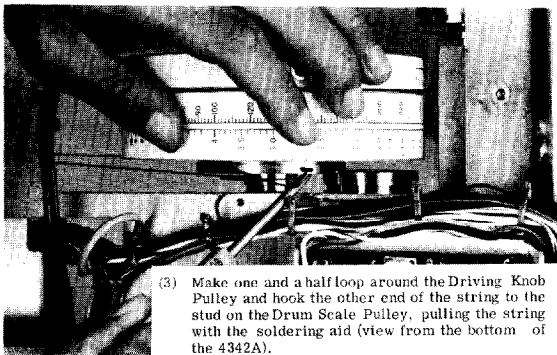

(3) Make one and a half loop around the Driving Knob Pulley and hook the other end of the string to the stud on the Drum Scale Pulley, pulling the string with the soldering aid (view from the bottom of the 4342A).

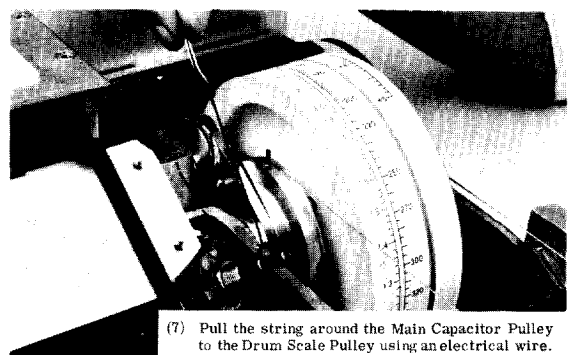

(7) Pull the string around the Main Capacitor Pulley to the Drum Scale Pulley using an electrical wire.

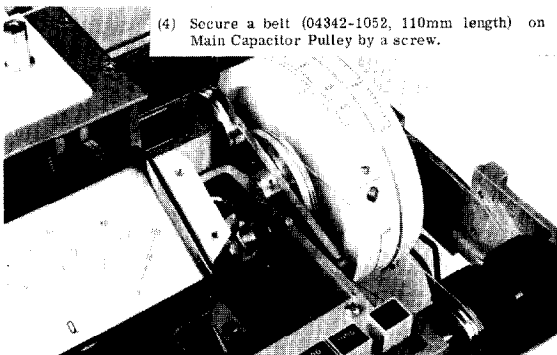

(4) Secure a belt (04342-1052, 110mm length) on Main Capacitor Pulley by a screw.

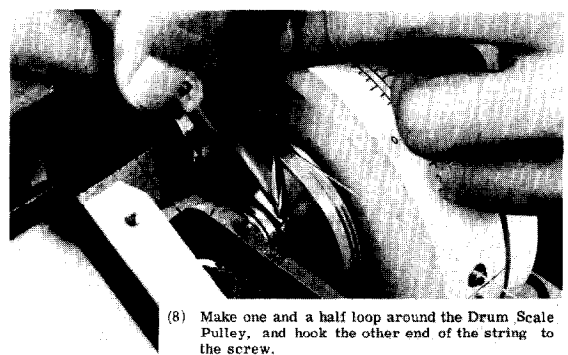

(8) Make one and a half loop around the Drum Scale Pulley, and hook the other end of the string to the screw.

Figure 5-9. Main C Dial Restringing.

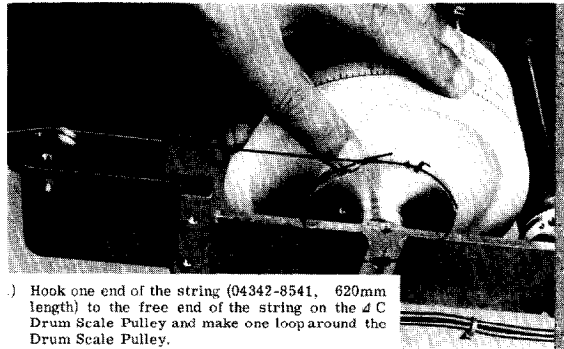

(1) Hook one end of the string (04342-8541, 620mm length) to the free end of the string on the Δ C Drum Scale Pulley and make one loop around the Drum Scale Pulley.

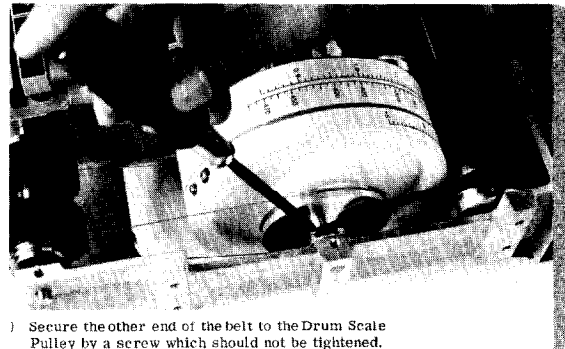

(5) Secure the other end of the belt to the Drum Scale Pulley by a screw which should not be tightened.

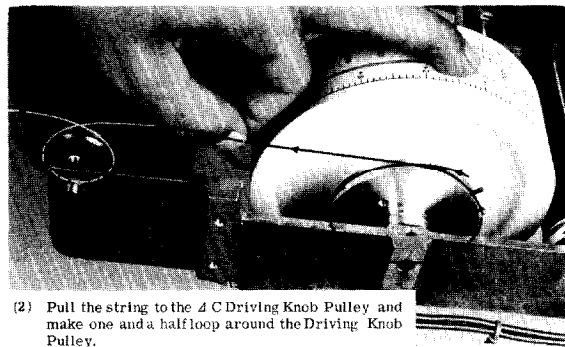

(2) Pull the string to the Δ C Driving Knob Pulley and make one and a half loop around the Driving Knob Pulley.

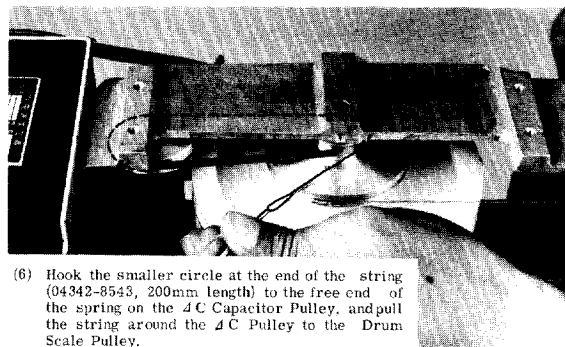

(6) Hook the smaller circle at the end of the string (04342-8543, 200mm length) to the free end of the string on the Δ C Capacitor Pulley, and pull the string around the Δ C Pulley to the Drum Scale Pulley.

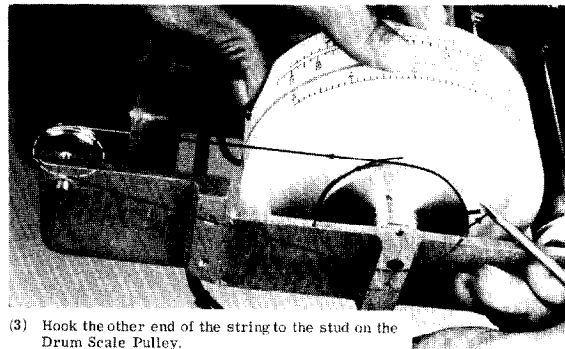

(3) Hook the other end of the string to the stud on the Drum Scale Pulley.

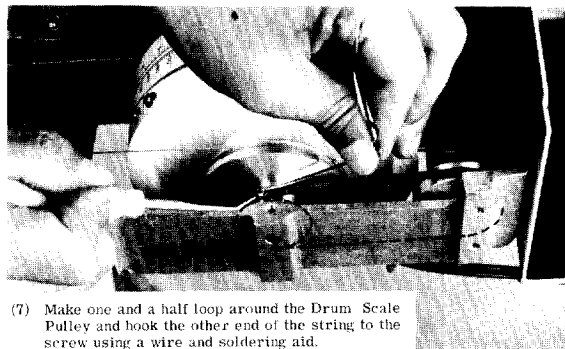

(7) Make one and a half loop around the Drum Scale Pulley and hook the other end of the string to the screw using a wire and soldering aid.

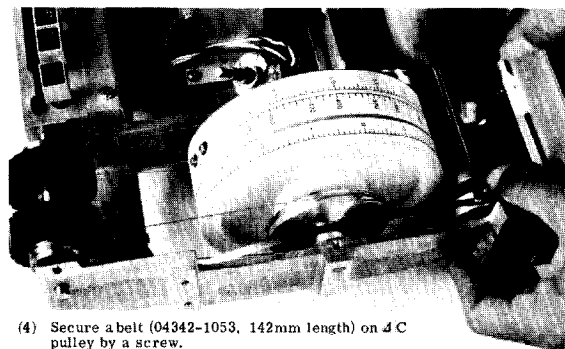

(4) Secure a belt (04342-1053, 142mm length) on Δ C pulley by a screw.

Figure 5-10. Δ C Dial Restringing.

5-37. TROUBLESHOOTING GUIDES.

5-38. This paragraph and those below provide information helpful to isolating a faulty circuit in a defective unit and the appropriate remedy for the trouble. Component level troubleshooting procedures are provided in Figures 5-13 and 5-14 in the form of flow diagrams [however, for simple circuits composed of only a few (active) components, these figures treat the breakdown only to circuit block level and component level troubleshooting procedure is omitted]. Before proceeding with troubleshooting, verify whether any external factor relating to the instrument operating environment is contributing to the trouble symptoms. The following paragraphs outline some considerations for such external troubles:

5-39. High Frequency Line Noise.

High frequency noise superposed on the AC power line may possibly cause an abnormal deflection of the Q meter regardless of the sample measured. If meter pointer shows almost the same deflection on any FREQUENCY and Q RANGE setting, check quality of operating power line. To isolate trouble, proceed as follows:

- 1) Operate the instrument from another ac power line and attempt measurement.
- 2) Securely ground the instrument chassis to earth.

If the symptom disappears or is different, use the same procedures on actual measurements or use a line filter in the power line.

5-40. Operating in a Strong Electromagnetic Field.

When the instrument is operated in a strong RF electromagnetic field, two (or more) resonant frequency points are sometimes observed on the Q meter indication. This symptom arises from the fact that the Q-measuring circuit resonates with the oscillator signal injected into the circuit and additionally with the RF signal induced by the electromagnetic field as well. In practice, this trouble sometimes occurs when the instrument is located near a high power transmitting station (such as a broadcasting station). The meter "true" tuning deflection can be easily distinguished from the "false" behavior because the amplitude of any meter

deflection caused by such external electromagnetic field is irrespective of the Q range. One solution to this trouble is to enclose the instrument in a grounded wire net shield. Securely ground the instrument.

5-41. Operation in High Humidity Environment.

The Q factor of a high Q inductor is generally sensitive to atmospheric humidity. Usually, ordinary high Q inductors tend to show a pronounced decrease in Q factor when they are located in a high humidity environment (more than 80%). If Q meter indicates a lower Q value (different from a nominal value of the sample), compare instrument reading by using a Q reference coil or a stable inductor (hermetically sealed).

5-42. ELEMENTARY TROUBLESHOOTING GUIDE.

5-43. Meter Zeroing Troubles.

If Q meter does not indicate zero after the instrument is turned on and if meter zero adjustment (Figure 3-6) is not successful, A6 DC Amplifier Assembly is probably faulty. Check differential meter amplifier (A6Q2, Q3, Q4 and Q5) and dc power supply voltages on the circuit board.

5-44. Incorrect Q Meter Indication.

If indicated Q values of Q measurements are incorrect (compared with a known sample), the trouble is probably located in either the oscillator section or the Q voltmeter section. (If no deflection at all can be obtained, first check power supply voltages). To isolate the trouble, proceed as follows:

- a. Connect a RF Voltmeter to 4342A LO and GND terminals.
- b. Set 4342A Q RANGE to 30.
- c. Rotate FREQUENCY dial from lowest to highest frequency on each FREQUENCY RANGE setting and check RF voltmeter reading.
- d. RF Voltmeter reading should be within $30\text{mV} \pm 0.9\text{mVrms}$ at any frequency setting. If this check fails, troubleshoot oscillator section and follow Figure 5-12 Troubleshooting Tree. If OK, troubleshoot voltmeter section and follow Figure 5-13 Troubleshooting Tree.

5-45. Low Q indication in high frequency measurements.

If the Q meter shows lower Q indication at higher frequencies (above approx. 10MHz), it is conceivable that the symptom is being caused by a drop in Q of the tuning capacitor. The tuning capacitor has a spring contact brush for grounding the capacitor rotor plates with minimal residual impedance to maintain the inherent loss of the capacitor at minimum in the high frequency region. A contact brush in service for a long period may possibly cause an increase in contact resistance and resultant increase in capacitor loss. The remedy for this trouble is to clean the contact brush. Clean with a cloth moistened with alcohol. To take out the contact brush, proceed as follows:

- a. Remove top cover.
- b. Remove white plastic top plate on measurement terminal deck.

- c. Unsolder center conductor (1) of coaxial module connected to A4 Impedance Converter (see Figure 5-11).
- d. Remove nut (2) retaining the coaxial assembly module.
- e. Remove the six terminal deck retaining screws (3).
- f. Lift terminal deck up and out. The contact brush is located on bottom side of terminal deck.

5-46. Faulty Q Limit Operation.

If 4342A operates normally in Q measurements but Q OVER LIMIT indication malfunctions, A7 Q Limit Selector assembly is probably faulty. If OVER LIMIT lamp does not light, first check lamp A10DS5.

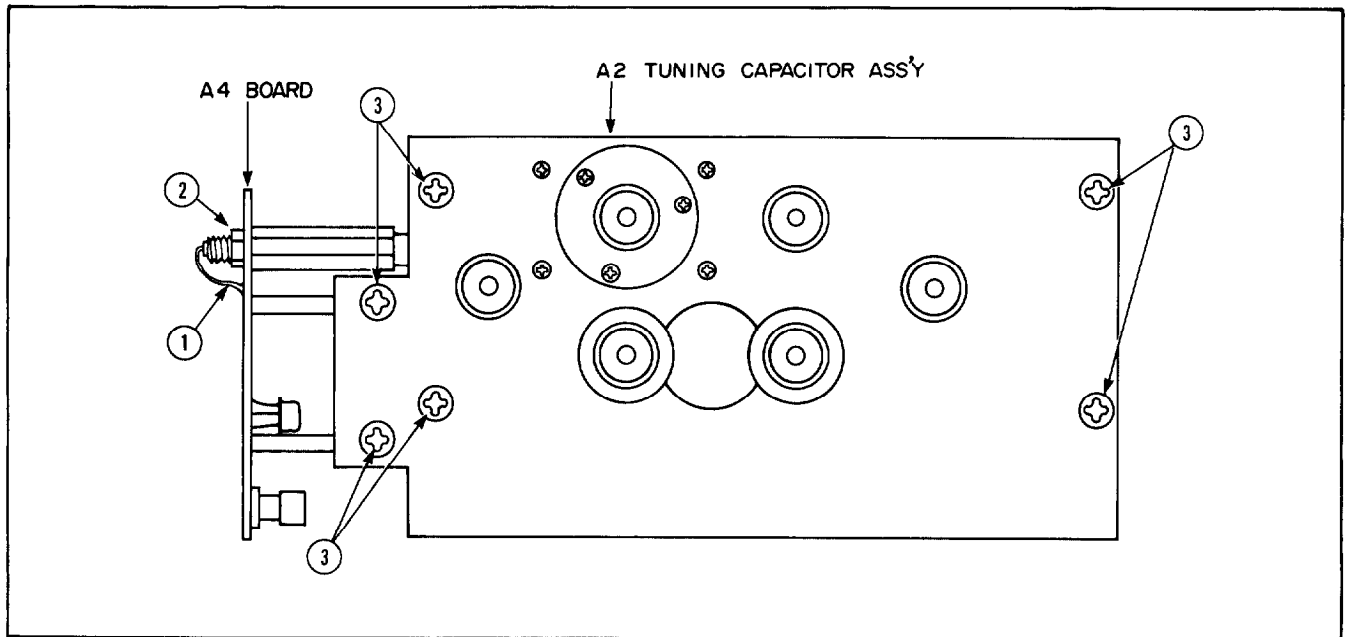

Figure 5-11. Tuning Capacitor Disassembly (top view).

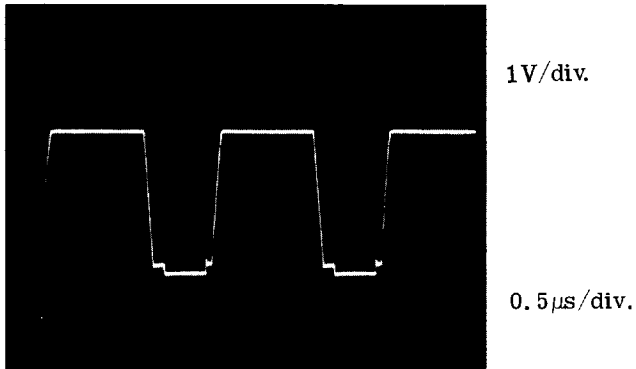

Figure A

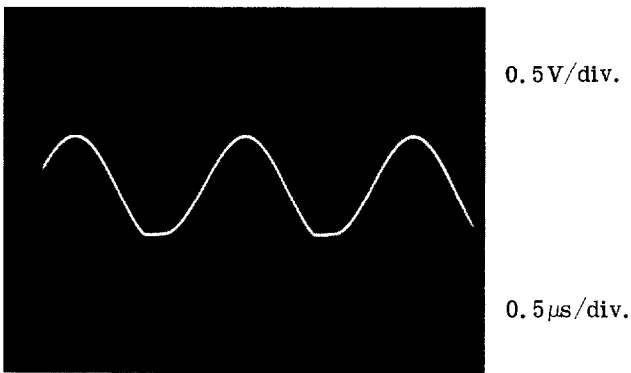

Figure B

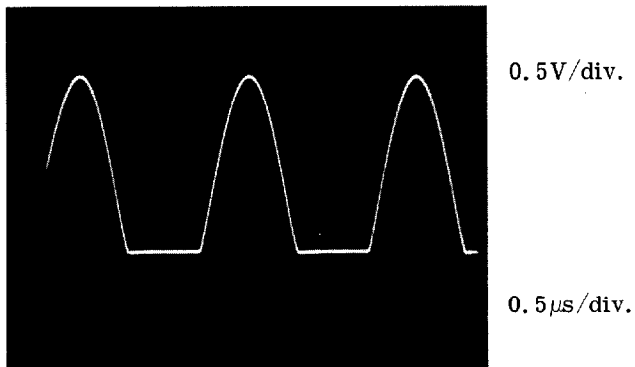

Figure C

Is there no output or is there erratic output at LO and GND terminals on all FREQUENCY ranges and Q Ranges?

YES

Set FR1 and FR2 Monitor T adapt within 1

NO

Is there output signals on RANGE

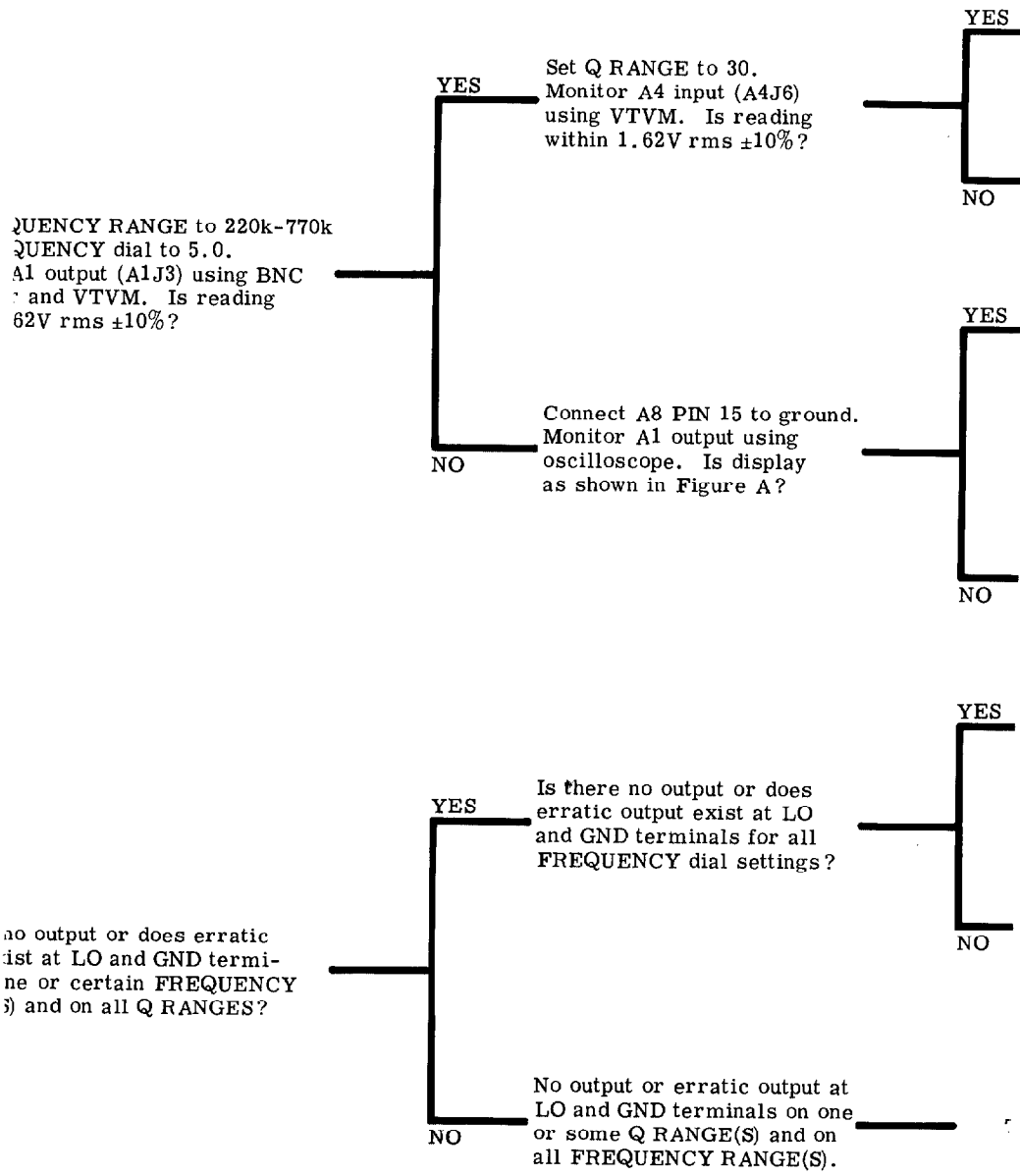



SEE INSIDE

Table 5-12.
TROUBLESHOOTING, OSCILLATOR SECTION

5-21

Monitor A4 output using VTVM.
 Is reading should be within 1.60V rms $\pm 10\%$?

YES — Check: A2T1

NO — Check: A4

— Check: A3 Q Range Attenuator.

Unsolder the wire from XA8 PIN S and connect a -23V to -24V dc variable power supply to the wire (Q1 Base) and GND. Observe A1 output waveform with oscilloscope. After adjustment of the variable power supply, can a distortion-free sine wave be seen on the oscilloscope?

YES — Remove connection lead between XA8 PIN 15 and ground. Keep A1 output at 4Vp-p and monitor DC voltage at XA8 PIN 15. Is voltmeter reading within -1.5Vdc $\pm 10\%$?

NO — Check: A1A1, Q1

Monitor DC voltage at XA8 PIN S. Is voltmeter reading -24Vdc $\pm 5\%$?

YES — Monitor waveform at A1A1 Q3 Gate using oscilloscope. Is display as shown in Figure B?

NO — Check: A8 ALC Amp. (Q9 through)

— Check: A1A1 (S1 and, L and C) identified with the FREQUENCY RANGE.

Connect A8 PIN 15 to ground. Observe A1 output using oscilloscope. Is display as shown in Figure A at any FREQUENCY dial setting?

YES — Check: A3 (C1 R1 and CR1 Frequer Response)

NO — Monitor DC voltage at XA8 PIN S. Is voltmeter reading -24Vdc $\pm 5\%$?

True — Check: A3 Q Range Attenuator.

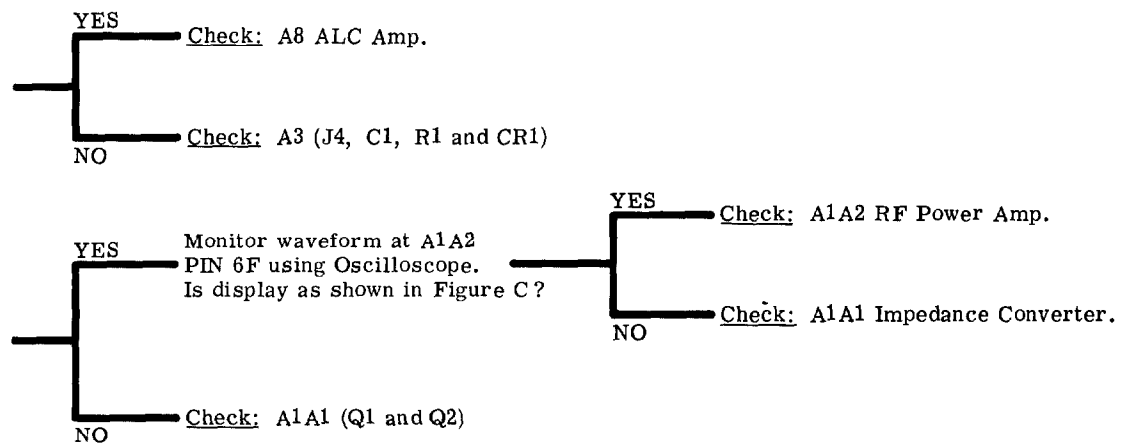

Q13)

icy

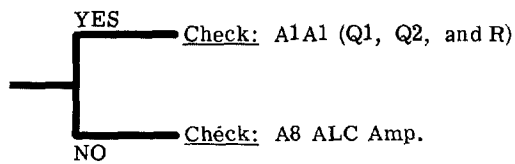

Figure 5-12. Troubleshooting, Oscillator Section

Does Q-meter indicate full scale ($\pm 3\%$) over the frequency range (from 22kHz to 70MHz)?

YES

NO

Connect an oscillator or to HI and GROUND terminals with a 50Ω resistor) and 0.9V rms (monitor with . Set C and 4C dials to mi



SEE INSIDE

Table 5-13.
TROUBLESHOOTING, VOLTMETER SECTION
5-23

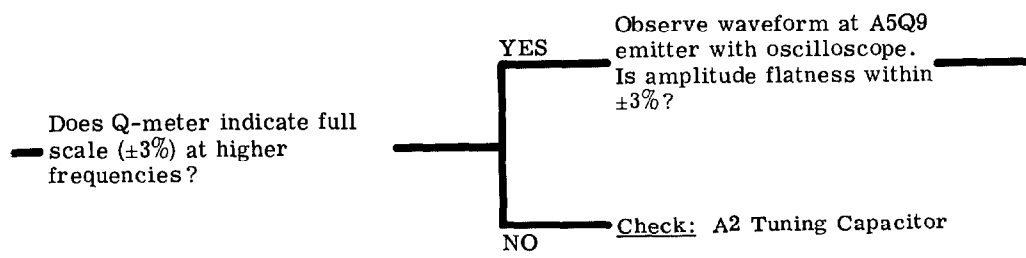
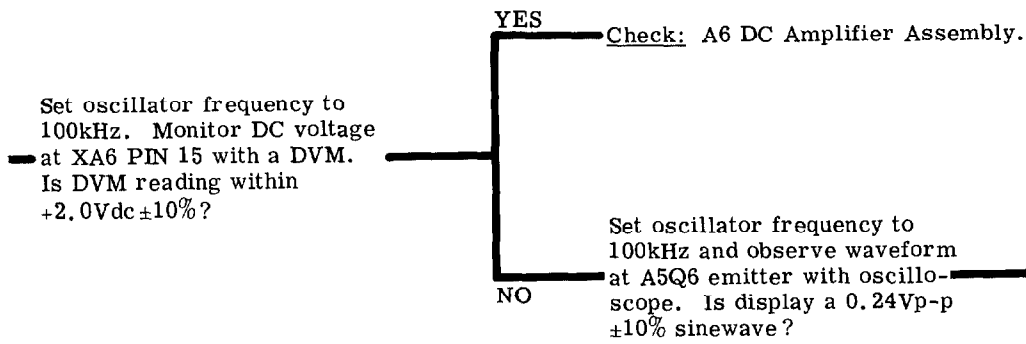

a signal generator
 nals (terminated
 set its output to
 an RF Voltmeter).
 nimum.

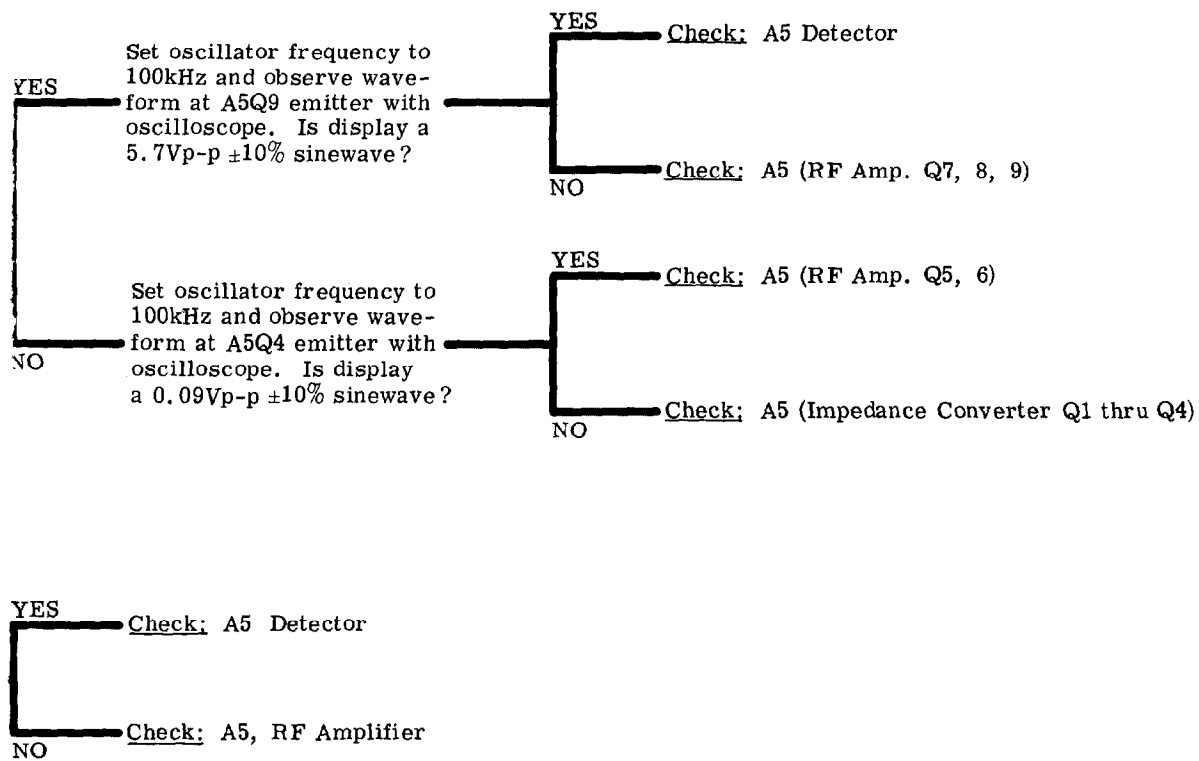

Figure 5-13. Troubleshooting, Voltmeter Section

PERFORMANCE CHECK TEST CARD

Hewlett-Packard Model 4342A
 Q Meter
 Serial No. _____

Test Performed by _____
 Date _____

DESCRIPTION	CHECK
1. FREQUENCY ACCURACY: STANDARD	
	Counter Reading
22 kHz - 70 kHz Range	22 kHz L 50 kHz 70 kHz
	21.670 kHz < _____ < 22.330 kHz 24.922 kHz < _____ < 25.424 kHz 49.250 kHz < _____ < 50.750 kHz 68.950 kHz < _____ < 71.050 kHz
70 kHz - 220 kHz Range	70 kHz L 150 kHz 220 kHz
	68.950 kHz < _____ < 71.050 kHz 78.822 kHz < _____ < 80.413 kHz 147.75 kHz < _____ < 152.25 kHz 216.70 kHz < _____ < 223.30 kHz
220 kHz - 700 kHz Range	220 kHz L 500 kHz 700 kHz
	216.70 kHz < _____ < 223.30 kHz 249.22 kHz < _____ < 254.24 kHz 492.50 kHz < _____ < 507.50 kHz 689.50 kHz < _____ < 710.50 kHz
700 kHz - 2.2 MHz Range	700 kHz L 1.5 MHz 2.2 MHz
	689.50 kHz < _____ < 710.50 kHz 788.22 kHz < _____ < 804.13 kHz 1477.5 kHz < _____ < 1522.5 kHz 2167.0 kHz < _____ < 2233.0 kHz
2.2 MHz - 7.0 MHz Range	2.2 MHz L 5.0 MHz 7.0 MHz
	2167.0 kHz < _____ < 2233.0 kHz 2492.2 kHz < _____ < 2542.4 kHz 4925.0 kHz < _____ < 5075.0 kHz 6895.0 kHz < _____ < 7105.0 kHz
7.0 MHz - 22 MHz Range	7.0 MHz L 15 MHz 22 MHz
	6895.0 kHz < _____ < 7105.0 kHz 7882.2 kHz < _____ < 8041.3 kHz 14.775 MHz < _____ < 15.225 MHz 21.670 MHz < _____ < 22.330 MHz
22 MHz - 70 MHz Range	22 MHz L 50 MHz 70 MHz
	21.560 MHz < _____ < 22.440 MHz 24.922 MHz < _____ < 25.424 MHz 49.000 MHz < _____ < 51.000 MHz 68.600 MHz < _____ < 71.400 MHz
1'. FREQUENCY ACCURACY: OPTION 001	
	Counter Reading
10 kHz - 32 kHz Range	10 kHz L 15 kHz 32 kHz
	9.8500 kHz < _____ < 10.150 kHz 14.775 kHz < _____ < 15.225 kHz 24.922 kHz < _____ < 25.424 kHz 31.520 kHz < _____ < 32.480 kHz
32 kHz - 100 kHz Range	32 kHz L 50 kHz 100 kHz
	31.520 kHz < _____ < 32.480 kHz 49.250 kHz < _____ < 50.750 kHz 78.822 kHz < _____ < 80.413 kHz 98.500 kHz < _____ < 101.50 kHz
100 kHz - 320 kHz Range	100 kHz L 150 kHz 320 kHz
	98.500 kHz < _____ < 101.50 kHz 147.75 kHz < _____ < 152.25 kHz 249.22 kHz < _____ < 254.24 kHz 315.20 kHz < _____ < 324.80 kHz

PERFORMANCE CHECK TEST CARD

<p>1'. FREQUENCY ACCURACY: OPTION 001 (Cont'd)</p> <table style="width: 100%; border: none;"> <tr> <td style="width: 30%; text-align: center;">320 kHz - 1.0 MHz Range</td> <td style="width: 30%;">320 kHz 500 kHz L 1.0 MHz</td> <td style="width: 40%;"></td> </tr> <tr> <td style="text-align: center;">1.0 MHz - 3.2 MHz Range</td> <td>1.0 MHz 1.5 MHz L 3.2 MHz</td> <td></td> </tr> <tr> <td style="text-align: center;">3.2 MHz - 10 MHz Range</td> <td>3.2 MHz 5.0 MHz L 10 MHz</td> <td></td> </tr> <tr> <td style="text-align: center;">10 MHz - 32 MHz Range</td> <td>10 MHz 15 MHz L 32 MHz</td> <td></td> </tr> </table>	320 kHz - 1.0 MHz Range	320 kHz 500 kHz L 1.0 MHz		1.0 MHz - 3.2 MHz Range	1.0 MHz 1.5 MHz L 3.2 MHz		3.2 MHz - 10 MHz Range	3.2 MHz 5.0 MHz L 10 MHz		10 MHz - 32 MHz Range	10 MHz 15 MHz L 32 MHz		<p style="text-align: center;">Counter Reading</p> <table style="width: 100%; border: none;"> <tr> <td style="width: 30%;">315.20 kHz</td> <td style="width: 30%; text-align: center;">< _____ ></td> <td style="width: 40%;">324.80 kHz</td> </tr> <tr> <td>492.50 kHz</td> <td style="text-align: center;">< _____ ></td> <td>507.50 kHz</td> </tr> <tr> <td>788.22 kHz</td> <td style="text-align: center;">< _____ ></td> <td>804.13 kHz</td> </tr> <tr> <td>985.00 kHz</td> <td style="text-align: center;">< _____ ></td> <td>1015.0 kHz</td> </tr> <tr> <td>985.00 kHz</td> <td style="text-align: center;">< _____ ></td> <td>1015.0 kHz</td> </tr> <tr> <td>1477.5 kHz</td> <td style="text-align: center;">< _____ ></td> <td>1522.5 kHz</td> </tr> <tr> <td>2492.2 kHz</td> <td style="text-align: center;">< _____ ></td> <td>2542.4 kHz</td> </tr> <tr> <td>3152.0 kHz</td> <td style="text-align: center;">< _____ ></td> <td>3248.0 kHz</td> </tr> <tr> <td>3152.0 kHz</td> <td style="text-align: center;">< _____ ></td> <td>3248.0 kHz</td> </tr> <tr> <td>4925.0 kHz</td> <td style="text-align: center;">< _____ ></td> <td>5075.0 kHz</td> </tr> <tr> <td>7882.2 kHz</td> <td style="text-align: center;">< _____ ></td> <td>8041.3 kHz</td> </tr> <tr> <td>9.8500 MHz</td> <td style="text-align: center;">< _____ ></td> <td>10.150 MHz</td> </tr> <tr> <td>9.8000 MHz</td> <td style="text-align: center;">< _____ ></td> <td>10.200 MHz</td> </tr> <tr> <td>14.700 MHz</td> <td style="text-align: center;">< _____ ></td> <td>15.300 MHz</td> </tr> <tr> <td>24.922 MHz</td> <td style="text-align: center;">< _____ ></td> <td>25.424 MHz</td> </tr> <tr> <td>31.360 MHz</td> <td style="text-align: center;">< _____ ></td> <td>32.640 MHz</td> </tr> </table>	315.20 kHz	< _____ >	324.80 kHz	492.50 kHz	< _____ >	507.50 kHz	788.22 kHz	< _____ >	804.13 kHz	985.00 kHz	< _____ >	1015.0 kHz	985.00 kHz	< _____ >	1015.0 kHz	1477.5 kHz	< _____ >	1522.5 kHz	2492.2 kHz	< _____ >	2542.4 kHz	3152.0 kHz	< _____ >	3248.0 kHz	3152.0 kHz	< _____ >	3248.0 kHz	4925.0 kHz	< _____ >	5075.0 kHz	7882.2 kHz	< _____ >	8041.3 kHz	9.8500 MHz	< _____ >	10.150 MHz	9.8000 MHz	< _____ >	10.200 MHz	14.700 MHz	< _____ >	15.300 MHz	24.922 MHz	< _____ >	25.424 MHz	31.360 MHz	< _____ >	32.640 MHz
320 kHz - 1.0 MHz Range	320 kHz 500 kHz L 1.0 MHz																																																												
1.0 MHz - 3.2 MHz Range	1.0 MHz 1.5 MHz L 3.2 MHz																																																												
3.2 MHz - 10 MHz Range	3.2 MHz 5.0 MHz L 10 MHz																																																												
10 MHz - 32 MHz Range	10 MHz 15 MHz L 32 MHz																																																												
315.20 kHz	< _____ >	324.80 kHz																																																											
492.50 kHz	< _____ >	507.50 kHz																																																											
788.22 kHz	< _____ >	804.13 kHz																																																											
985.00 kHz	< _____ >	1015.0 kHz																																																											
985.00 kHz	< _____ >	1015.0 kHz																																																											
1477.5 kHz	< _____ >	1522.5 kHz																																																											
2492.2 kHz	< _____ >	2542.4 kHz																																																											
3152.0 kHz	< _____ >	3248.0 kHz																																																											
3152.0 kHz	< _____ >	3248.0 kHz																																																											
4925.0 kHz	< _____ >	5075.0 kHz																																																											
7882.2 kHz	< _____ >	8041.3 kHz																																																											
9.8500 MHz	< _____ >	10.150 MHz																																																											
9.8000 MHz	< _____ >	10.200 MHz																																																											
14.700 MHz	< _____ >	15.300 MHz																																																											
24.922 MHz	< _____ >	25.424 MHz																																																											
31.360 MHz	< _____ >	32.640 MHz																																																											
<p>2. Q RANGE</p> <table style="width: 100%; border: none;"> <tr> <td style="width: 30%; text-align: center;">Q Range</td> <td style="width: 30%;">30 100 300 1000</td> <td style="width: 40%;"></td> </tr> </table>	Q Range	30 100 300 1000		<p style="text-align: center;">Digital Voltmeter Reading</p> <table style="width: 100%; border: none;"> <tr> <td style="width: 30%;">920.6 mV</td> <td style="width: 30%; text-align: center;">< _____ ></td> <td style="width: 40%;">977.4 mV</td> </tr> <tr> <td>873.0 mV</td> <td style="text-align: center;">< _____ ></td> <td>927.0 mV</td> </tr> <tr> <td>920.6 mV</td> <td style="text-align: center;">< _____ ></td> <td>977.4 mV</td> </tr> <tr> <td>873.0 mV</td> <td style="text-align: center;">< _____ ></td> <td>927.0 mV</td> </tr> </table>	920.6 mV	< _____ >	977.4 mV	873.0 mV	< _____ >	927.0 mV	920.6 mV	< _____ >	977.4 mV	873.0 mV	< _____ >	927.0 mV																																													
Q Range	30 100 300 1000																																																												
920.6 mV	< _____ >	977.4 mV																																																											
873.0 mV	< _____ >	927.0 mV																																																											
920.6 mV	< _____ >	977.4 mV																																																											
873.0 mV	< _____ >	927.0 mV																																																											
<p>3. ΔQ RANGE</p> <table style="width: 100%; border: none;"> <tr> <td style="width: 30%; text-align: center;">Q Range</td> <td style="width: 30%;">100</td> <td style="width: 40%;"></td> </tr> <tr> <td style="text-align: center;">ΔQ Range</td> <td>10</td> <td></td> </tr> </table>	Q Range	100		ΔQ Range	10		<p style="text-align: center;">Digital Voltmeter Reading</p> <table style="width: 100%; border: none;"> <tr> <td style="width: 30%;">873.0 mV</td> <td style="width: 30%; text-align: center;">< _____ ></td> <td style="width: 40%;">927.0 mV</td> </tr> <tr> <td>801.9mV</td> <td style="text-align: center;">< _____ ></td> <td>818.1mV</td> </tr> </table>	873.0 mV	< _____ >	927.0 mV	801.9mV	< _____ >	818.1mV																																																
Q Range	100																																																												
ΔQ Range	10																																																												
873.0 mV	< _____ >	927.0 mV																																																											
801.9mV	< _____ >	818.1mV																																																											
<p>4. CAPACITANCE ACCURACY</p> <table style="width: 100%; border: none;"> <tr> <td style="width: 30%; text-align: center;">C Dial</td> <td style="width: 30%; text-align: center;">ΔC Dial</td> <td style="width: 40%;"></td> </tr> <tr> <td>25 pF</td> <td style="text-align: center;">0</td> <td></td> </tr> <tr> <td>25 pF</td> <td style="text-align: center;">-5 pF</td> <td></td> </tr> <tr> <td>25 pF</td> <td style="text-align: center;">+5 pF</td> <td></td> </tr> <tr> <td>100 pF</td> <td style="text-align: center;">0</td> <td></td> </tr> <tr> <td>200 pF</td> <td style="text-align: center;">0</td> <td></td> </tr> <tr> <td>300 pF</td> <td style="text-align: center;">0</td> <td></td> </tr> <tr> <td>400 pF</td> <td style="text-align: center;">0</td> <td></td> </tr> <tr> <td>470 pF</td> <td style="text-align: center;">0</td> <td></td> </tr> <tr> <td>470 pF</td> <td style="text-align: center;">+5 pF</td> <td></td> </tr> </table>	C Dial	ΔC Dial		25 pF	0		25 pF	-5 pF		25 pF	+5 pF		100 pF	0		200 pF	0		300 pF	0		400 pF	0		470 pF	0		470 pF	+5 pF		<p style="text-align: center;">Capacitance Bridge Reading</p> <table style="width: 100%; border: none;"> <tr> <td style="width: 30%;">23.9pF</td> <td style="width: 30%; text-align: center;">< _____ ></td> <td style="width: 40%;">26.1pF</td> </tr> <tr> <td>(0 Reading)* -5.1pF</td> <td style="text-align: center;">< _____ ></td> <td>(0 Reading)* -4.9pF</td> </tr> <tr> <td>(0 Reading)* +4.9pF</td> <td style="text-align: center;">< _____ ></td> <td>(0 Reading)* +5.1pF</td> </tr> <tr> <td>98.9pF</td> <td style="text-align: center;">< _____ ></td> <td>101.1pF</td> </tr> <tr> <td>197.9pF</td> <td style="text-align: center;">< _____ ></td> <td>202.1pF</td> </tr> <tr> <td>296.9pF</td> <td style="text-align: center;">< _____ ></td> <td>303.1pF</td> </tr> <tr> <td>395.9pF</td> <td style="text-align: center;">< _____ ></td> <td>404.1pF</td> </tr> <tr> <td>465.2pF</td> <td style="text-align: center;">< _____ ></td> <td>474.8pF</td> </tr> <tr> <td>(0 Reading)* +4.9pF</td> <td style="text-align: center;">< _____ ></td> <td>(0 Reading)* +5.1pF</td> </tr> </table> <p style="font-size: small;">* Note: 0 Reading is the readout of the Capacitance Bridge when C Dial is set to 0.</p>	23.9pF	< _____ >	26.1pF	(0 Reading)* -5.1pF	< _____ >	(0 Reading)* -4.9pF	(0 Reading)* +4.9pF	< _____ >	(0 Reading)* +5.1pF	98.9pF	< _____ >	101.1pF	197.9pF	< _____ >	202.1pF	296.9pF	< _____ >	303.1pF	395.9pF	< _____ >	404.1pF	465.2pF	< _____ >	474.8pF	(0 Reading)* +4.9pF	< _____ >	(0 Reading)* +5.1pF			
C Dial	ΔC Dial																																																												
25 pF	0																																																												
25 pF	-5 pF																																																												
25 pF	+5 pF																																																												
100 pF	0																																																												
200 pF	0																																																												
300 pF	0																																																												
400 pF	0																																																												
470 pF	0																																																												
470 pF	+5 pF																																																												
23.9pF	< _____ >	26.1pF																																																											
(0 Reading)* -5.1pF	< _____ >	(0 Reading)* -4.9pF																																																											
(0 Reading)* +4.9pF	< _____ >	(0 Reading)* +5.1pF																																																											
98.9pF	< _____ >	101.1pF																																																											
197.9pF	< _____ >	202.1pF																																																											
296.9pF	< _____ >	303.1pF																																																											
395.9pF	< _____ >	404.1pF																																																											
465.2pF	< _____ >	474.8pF																																																											
(0 Reading)* +4.9pF	< _____ >	(0 Reading)* +5.1pF																																																											
<p>5. Q OVER LIMIT OPERATION</p> <table style="width: 100%; border: none;"> <tr> <td style="width: 30%;">Q Limit Setting</td> <td style="width: 30%;">60</td> <td style="width: 40%;"></td> </tr> <tr> <td>Meter Indication</td> <td>50</td> <td></td> </tr> <tr> <td>Meter Indication</td> <td>≥ 60</td> <td></td> </tr> </table>	Q Limit Setting	60		Meter Indication	50		Meter Indication	≥ 60		<p style="text-align: center;">Over Limit Lamp</p> <table style="width: 100%; border: none;"> <tr> <td style="width: 30%;">On</td> <td style="width: 30%; text-align: center;"><input type="checkbox"/></td> <td style="width: 40%;"></td> </tr> <tr> <td>Off</td> <td style="text-align: center;"><input type="checkbox"/></td> <td></td> </tr> <tr> <td>On</td> <td style="text-align: center;"><input type="checkbox"/></td> <td></td> </tr> </table>	On	<input type="checkbox"/>		Off	<input type="checkbox"/>		On	<input type="checkbox"/>																																											
Q Limit Setting	60																																																												
Meter Indication	50																																																												
Meter Indication	≥ 60																																																												
On	<input type="checkbox"/>																																																												
Off	<input type="checkbox"/>																																																												
On	<input type="checkbox"/>																																																												

SECTION VI REPLACEABLE PARTS

6-1. INTRODUCTION

6-2. This section contains information for ordering replacement parts. Table 6-2 lists parts in alpha-numerical order of their reference designators and indicates the description (see Table 6-1 for abbreviations used) and HP part number of each part, together with any applicable notes.

6-3. Miscellaneous parts associated with each assembly are listed at the end of each assembly listing. Others are listed at the end of Table 6-2.

6-4. Exploded views of major parts of the instrument are given in Figure 6-1 through 6-8 to aid in identifying mechanical parts. The parts in these figures are keyed to the mechanical parts index which are also included in each figure.

6-5. Replaceable Part Lists for Option 001 are given in Appendix. Changes were made in Assembly A1A1 and Assembly A5 only.

6-6. ORDERING INFORMATION

6-7. To obtain replacement parts, address order or inquiry to your local Hewlett-Packard Field Office (see lists at rear of this manual for addresses). Identify parts by their Hewlett-Packard part numbers.

6-8. To obtain a part that is not listed, include:

- a. Instrument model number.
- b. Instrument serial number
- c. Description of the part.
- d. Function and location of the part.

Table 6-1. List of Reference Designators and Abbreviations

REFERENCE DESIGNATORS					
<p>A = assembly B = motor BT = battery C = capacitor CP = coupler CR = diode DL = delay line DS = device signaling (lamp)</p>	<p>E = misc electronic part F = fuse FL = filter J = jack K = relay L = inductor M = meter MP = mechanical part</p>	<p>P = plug Q = transistor R = resistor RT = thermistor S = switch T = transformer TB = terminal board TP = test point</p>	<p>V = vacuum, tube, neon bulb, photocell, etc. VR = voltage regulator W = cable X = socket Y = crystal</p>		
ABBREVIATIONS					
<p>A = amperes A. F. C. = automatic frequency control AMPL = amplifier B. F. O. = beat frequency oscillator BE CU = beryllium copper BH = binder head BP = bandpass BRS = brass BWO = backward wave oscillator CCW = counter-clockwise CER = ceramic CMO = cabinet mount only COEF = coefficient COM = common COMP = composition COMPL = complete CONN = connector CP = cadmium plate CRT = cathode-ray tube CW = clockwise DEPC = deposited carbon DR = drive ELECT = electrolytic ENCAP = encapsulated EXT = external F = farads FH = flat head FIL H = fillister head FXD = fixed GE = germanium GL = glass GRD = ground(ed)</p>	<p>H = henries HEX = hexagonal HG = mercury HR = hour(s) IF = intermediate freq IMPG = impregnated INCD = incandescent INCL = include(s) INS = insulation(ed) INT = internal K = kilo = 1000 LH = left hand LIN = linear taper LK WASH = lock washer LOG = logarithmic taper LPF = low pass filter M = milli = 10⁻³ MEG = meg = 10⁶ MET FLM = metal film MET OX = metallic oxide MFR = manufacturer MINAT = miniature MOM = momentary MTG = mounting MY = "mylar" N = nano (10⁻⁹) N/C = normally closed NE = neon NI PL = nickel plate N/O = normally open NPO = negative positive zero (zero temperature coefficient)</p>	<p>NPN = negative-positive-negative NRFR = not recommended for field replacement NSR = not separately replaceable OBD = order by description OH = oval head OX = oxide P = peak PC = printed circuit PF = picofarads = 10⁻¹² farads PH BRZ = phosphor bronze PHL = Phillips PIV = peak inverse voltage PNP = positive-negative-positive P/O = part of POLY = polystyrene PORC = porcelain POS = position(s) POT = potentiometer PP = peak-to-peak PT = point PWV = peak working voltage RECT = rectifier RF = radio frequency RH = round head or right hand RMO = rack mount only</p>	<p>RMS = root-mean square RWV = reverse working voltage S-B = slow-blow SCR = screw SE = selenium SECT = section(s) SEMICON = semiconductor SI = silicon SIL = silver SL = slide SPG = spring SPL = special SST = stainless steel SR = split ring STL = steel TA = tantalum TD = time delay TGL = toggle THD = thread TI = titanium TOL = tolerance TRIM = trimmer TWT = traveling wave tube U = micro = 10⁻⁶ VAR = variable VDCW = dc working volts W/ = with W = watts WIV = working inverse voltage WW = wirewound W/O = without</p>		

Table 6-2. Reference Designation Index

Reference Designation	Part No.	Description	Note
A1	04342-7020	OSCILLATOR ASS'Y	
A1A1	04342-7751 04342-8751	OSCILLATOR BOARD ASS'Y BOARD:BLANK PC	
A1A1C1	0121-0236	C:VAR CER CYLINDER 0.8 - 8.5pF	
A1A1C2*	0160-2248	C:FXD CER 4.3pF ±0.25pF 500VDCW	
A1A1C3	0121-0236	C:VAR CER CYLINDER 0.8 - 8.5pF	
A1A1C4*	0150-2243	C:FXD CER 2.7pF ±0.25pF 500VDCW	
A1A1C5	0121-0236	C:VAR CER CYLINDER 0.8 - 8.5pF	
A1A1C6*	0160-2240	C:FXD CER 2.0pF ±0.25pF 500VDCW	
A1A1C7	0121-0236	C:VAR CER CYLINDER 0.8 - 8.5pF	
A1A1C8*	0160-2247	C:FXD CER 3.9pF ±0.25pF 500VDCW	
A1A1C9	0121-0236	C:VAR CER CYLINDER 0.8 - 8.5pF	
A1A1C10*	0160-2253	C:FXD CER 6.8pF ±0.25pF 500VDCW	
A1A1C11	0121-0236	C:VAR CER CYLINDER 0.8 - 8.5pF	
A1A1C12*	0160-2256	C:FXD CER 9.1pF ±0.25pF 500VDCW	
A1A1C13	0121-0236	C:VAR CER CYLINDER 0.8 - 8.5pF	
A1A1C14*	0160-2241	C:FXD CER 2.2pF ±0.25pF 500VDCW	
A1A1C15		NOT ASSIGNED	
A1A1C16		NOT ASSIGNED	
A1A1C17	0180-1743	C:FXD TA 0.1μF 10% 35VDCW	
A1A1C18	0160-2264	C:FXD CER 20pF 5% 500VDCW	
A1A1C19	0160-0417	C:FXD CER 150pF 10% 500VDCW	
A1A1C20	0121-0232	C:VAR AIR 12 - 460pF	
A1A1C21	0160-2238	C:FXD CER 1.5pF 500VDCW	
A1A1C22	0180-0291	C:FXD TA 1μF 10% 35VDCW	
A1A1C23*	0160-2251	C:FXD CER 5.6pF 500VDCW	
A1A1C24	0180-0116	C:FXD TA 6.8μF 10% 35VDCW	
A1A1C25		NOT ASSIGNED	
A1A1C26	0180-0291	C:FXD TA 1μF 10% 35VDCW	
A1A1C27	0180-0116	C:FXD TA 6.8μF 10% 35VDCW	
A1A1C28	0160-2266	C:FXD CER 24pF 5% 500VDCW	
A1A1C29	0160-2266	C:FXD CER 24pF 5% 500VDCW	
A1A1C30	0180-0116	C:FXD TA 6.8μF 10% 35VDCW	
A1A1C31	0150-0093	C:FXD CER 0.01μF -20% +80% 100VDCW	
A1A1L1	04342-8603	COIL:VAR 39 - 58mH	
A1A1L2	04342-8604	COIL:VAR 9 - 14mH	
A1A1L3	04342-8605	COIL:VAR 1 - 1.6mH	
A1A1L4	04342-8606	COIL:VAR 102 - 150μH	
A1A1L5	04342-8607	COIL:VAR 11 - 15μH	

See list of abbreviations in introduction to this section

Table 6-2. Reference Designation Index (Cont'd)

Reference Designation	Part No.	Description	Note
A1A1L6	04342-8608	COIL:VAR 1 - 1.3 μ H	
A1A1L7	04342-8609	COIL:VAR 0.09 - 0.1 μ H	
A1A1L8	9170-0029	MAGNETIC CORE:BEAD FERRITE	
A1A1L9	9170-0029	MAGNETIC CORE:BEAD FERRITE	
A1A1L10	9170-0029	MAGNETIC CORE:BEAD FERRITE	
A1A1Q1	1854-0071	TRANSISTOR:NPN SILICON	
A1A1Q2	1854-0092	TRANSISTOR:NPN SILICON	
A1A1Q3	1855-0022	TRANSISTOR:FIELD EFFECT N-CHANNEL	
A1A1Q4	1853-0034	TRANSISTOR:PNP SILICON	
A1A1Q5	1854-0019	TRANSISTOR:NPN SILICON	
A1A1Q6	1854-0019	TRANSISTOR:NPN SILICON	
A1A1R1*	0757-1094	R:FXD MET FLM 1.47k Ω 1% 1/8W	
A1A1R2*	0757-0417	R:FXD MET FLM 562 Ω 1% 1/8W	
A1A1R3*	0757-0411	R:FXD MET FLM 332 Ω 1% 1/8W	
A1A1R4*	0698-3488	R:FXD MET FLM 442 Ω 1% 1/8W	
A1A1R5*	0698-3446	R:FXD MET FLM 383 Ω 1% 1/8W	
A1A1R6*	0698-6324	R:FXD MET FLM 187 Ω 1% 1/8W	
A1A1R7*	0698-3243	R:FXD MET FLM 178k Ω 1% 1/8W	
A1A1R8	0698-0085	R:FXD MET FLM 2.61k Ω 1% 1/8W	
A1A1R9	0698-3359	R:FXD MET FLM 12.7k Ω 1% 1/8W	
A1A1R10	0757-0279	R:FXD MET FLM 3.16k Ω 1% 1/8W	
A1A1R11	0698-3156	R:FXD MET FLM 14.7k Ω 1% 1/8W	
A1A1R12	0683-2265	R:FXD COMP 22M Ω 5% 1/4W	
A1A1R13	0757-0123	R:FXD MET FLM 34.8k Ω 1% 1/8W	
A1A1R14	0757-0442	R:FXD MET FLM 10k Ω 1% 1/8W	
A1A1R15	0698-3156	R:FXD MET FLM 14.7k Ω 1% 1/8W	
A1A1R16	0698-3153	R:FXD MET FLM 3.83k Ω 1% 1/8W	
A1A1R17	0698-3151	R:FXD MET FLM 2.87k Ω 1% 1/8W	
A1A1R18	0698-4453	R:FXD MET FLM 402 Ω 1% 1/8W	
A1A1R19	0698-4125	R:FXD MET FLM 953 Ω 1% 1/8W	
A1A1R20*	0757-0401	R:FXD MET FLM 100 Ω 1% 1/8W	
A1A1R21	0757-0821	R:FXD MET FLM 1.21k Ω 1% 1/2W	
A1A1R22	0757-0346	R:FXD MET FLM 10 Ω 1% 1/8W	
A1A1R23	0757-0453	R:FXD MET FLM 30.1k Ω 1% 1/8W	
A1A1S1	3101-0260	SWITCH:PUSH BUTTON 7-RANGE	
A1A1XA1A2	1251-0478	CONNECTOR:PRINTED CIRCUIT 12-CONTACT	
		MISCELLANEOUS	
	04342-1026	PLATE:ANGLE	
	04342-3022	NUT:HEX FOR FERRITE CORE 7 REQ'D	

See list of abbreviations in introduction to this section

Table 6-2. Reference Designation Index (Cont'd)

Reference Designation	Part No.	Description	Note
A1A2	04342-7702 04342-8702	RF POWER AMPLIFIER ASS'Y BOARD:BLANK PC	
A1A2C1	0180-0116	C:FXD TA 6.8 μ F 10% 35VDCW	
A1A2C2	0180-0376	C:FXD TA 0.47 μ F 10% 35VDCW	
A1A2C3	0180-0116	C:FXD TA 6.8 μ F 10% 35VDCW	
A1A2C4	0180-0197	C:FXD TA 2.2 μ F 10% 20VDCW	
A1A2C5	0180-0116	C:FXD TA 6.8 μ F 10% 35VDCW	
A1A2C6	0160-2203	C:FXD MICA 91pF 5% 300VDCW	
A1A2C7	0180-0116	C:FXD TA 6.8 μ F 10% 35VDCW	
A1A2J1	1250-0257	CONNECTOR:RF FEMALE	
A1A2L1	9140-0158	COIL:FXD RF 1 μ H 10%	
A1A2L2	9140-0098	COIL:FXD RF 2.2 μ H 10%	
A1A2L3	9170-0029	MAGNETIC CORE:BEAD FERRITE	
A1A2L4	9170-0029	MAGNETIC CORE:BEAD FERRITE	
A1A2Q1	1854-0091	TRANSISTOR:NPN SILICON	
A1A2Q2	1854-0091	TRANSISTOR:NPN SILICON	
A1A2Q3	1854-0091	TRANSISTOR:NPN SILICON	
A1A2Q4	1854-0332	TRANSISTOR:NPN SILICON	
A1A2R1	0757-0395	R:FXD MET FLM 56.2 Ω 1% 1/8W	
A1A2R2	0698-0085	R:FXD MET FLM 2.61k Ω 1% 1/8W	
A1A2R3	0698-4422	R:FXD MET FLM 1.27k Ω 1% 1/8W	
A1A2R4	0757-0424	R:FXD MET FLM 1.1k Ω 1% 1/8W	
A1A2R5	0757-0394	R:FXD MET FLM 51.1 Ω 1% 1/8W	
A1A2R6	0698-4418	R:FXD MET FLM 205 Ω 1% 1/8W	
A1A2R7	0757-0294	R:FXD MET FLM 17.8 Ω 1% 1/8W	
A1A2R8	0757-0294	R:FXD MET FLM 17.8 Ω 1% 1/8W	
A1A2R9	0698-3439	R:FXD MET FLM 178 Ω 1% 1/8W	
A1A2R10	0698-3438	R:FXD MET FLM 147 Ω 1% 1/8W	
A1A2R11	0698-3430	R:FXD MET FLM 21.5 Ω 1% 1/8W	
A1A2R12	0757-0159	R:FXD MET FLM 1000 Ω 1% 1/2W	
A1A2R13	0698-3628	R:FXD MET OX 220 Ω 5% 2W	
	1205-0007	MISCELLANEOUS	
	1205-0008	HEAT DISSIPATOR NUT HEAT DISSIPATOR BODY	
A1A3	04342-8709	BOARD:WIRING	

See list of abbreviations in introduction to this section

Table 6-2. Reference Designation Index (Cont'd)

Reference Designation	Part No.	Description	Note
A1C1 A1C2 A1C3	0160-2357 0160-2357 0160-2357	C:FXD CER 1000pF -20% +80% C:FXD CER 1000pF -20% +80% C:FXD CER 1000pF -20% +80%	
A1J1 A1J2 A1J3	1250-0083 1250-0252 1250-0050 1250-0051	NOT ASSIGNED CONNECTOR:BNC FEMALE CONNECTOR:BNC FEMALE PART OF A1W1 NUT:RF CONNECTOR PART OF A1J3 CONTACT:RF CONNECTOR PART OF A1J3	
A1P1	1250-0872	CONNECTOR:RF MALE PART OF A1W1	
A1W1	04342-7601	CABLE ASS'Y:INTER CONNECTING INCLUDING A1J3 AND A1P1	
		MISCELLANEOUS	
		See Figure 6-1.	

See list of abbreviations in introduction to this section

Table 6-2. Reference Designation Index (Cont'd)

Reference Designation	Part No.	Description	Note
A2	04342-7201	TUNING CAPACITOR ASS'Y* (See Note below).	
A2C1		C:VAR AIR MAIN 25 - 475pF NOT SEPARATELY REPLACEABLE PART OF A2	
A2C2		C:VAR AIR VERNIER -5 - +5pF NOT SEPARATELY REPLACEABLE PART OF A2	
A2C3	04342-7205	C:FXD AIR 2pF INCLUDING C4	
A2C4	0140-0074	C:FXD MICA 56pF 10% 500VDCW NOT SEPARATELY REPLACEABLE PART OF C3	
A2J1		NOT SEPARATELY REPLACEABLE	
A2J2	04342-3259	CAP:BINDING POST	
A2J2		NOT SEPARATELY REPLACEABLE	
A2J3	04342-3259	CAP:BINDING POST	
A2J3	04342-3239	CONNECTOR:HEXAGONAL GROUND LUG	
A2J4	04342-3232	BODY:GROUND LUG	
A2J4		NOT SEPARATELY REPLACEABLE	
A2J5	04342-3259	CAP:BINDING POST	
A2J5		NOT SEPARATELY REPLACEABLE	
A2J6	04342-3259	CAP:BINDING POST	
A2J6	04342-3239	CONNECTOR:HEXAGONAL GROUND LUG	
A2J6	04342-3232	BODY:GROUND LUG	
A2R1	0757-0398	R:FXD MET FLM 75Ω 1% 1/8W	
A2T1	04342-8601	TRANSFORMER:INJECTION	
A2T1	04342-00602	SCALE 4C	
A2T1	04342-00601	SCALE C	
		MISCELLANEOUS	
		See Figure 6-2.	
		Note	
		Tuning Capacitor Ass'y Service Kit is available with Part No. 04342-65001. This kit includes:	
		P/N 04342-7201: TUNING CAPACITOR ASS'Y	
		P/N 04342-00602: SCALE 4C	
		P/N 04342-00601: SCALE C	
		P/N 04342-3267: HEXAGONAL GND LUG	
		P/N 04342-3259: BINDING POST	
		P/N 04342-3256: TERMINAL TEFLON	

See list of abbreviations in introduction to this section

Table 6-2. Reference Designation Index (Cont'd)

Reference Designation	Part No.	Description	Note
A3	04342-7703 04342-8703	Q RANGE ATTENUATOR ASS'Y BOARD:BLANK PC	
A3C1	0160-2145	C:FXD CER 0.005 μ F -20% +80%	
A3CR1	1901-0347	SEMICON DEVICE:DIODE HOT CARRIER	
A3J1		NOT ASSIGNED	
A3J2		NOT ASSIGNED	
A3J3		NOT ASSIGNED	
A3J4	1250-0257	CONNECTOR:RF FEMALE	
A3J5	1250-0257	CONNECTOR:RF FEMALE	
A3R1	0757-0482	R:FXD MET FLM 511k Ω 1% 1/8W	
A3R2	0698-2041	R:FXD MET FLM 10.4dB \pm 0.1dB	
A3R3	0698-2040	R:FXD MET FLM 9.6dB \pm 0.1dB	
A3R4	0698-2041	R:FXD MET FLM 10.4dB \pm 0.1dB	
A3S1	3101-0262	SWITCH:PUSH BUTTON 4-RANGE	
A3S2	3101-0261	SWITCH:PUSH BUTTON 1-RANGE	
		MISCELLANEOUS	
	04342-1047 04342-1055	PLATE:SHIELD MOUNTED ON PC BOARD BRACKET:SHIELD MOUNTED ON PC BOARD See Figure 6-3.	

See list of abbreviations in introduction to this section

Table 6-2. Reference Designation Index (Cont'd)

Reference Designation	Part No.	Description	Note
A4	04342-7704 04342-8704	IMPEDANCE CONVERTER ASS'Y BOARD:BLANK PC	
A4C1	0180-0291	C:FXD TA 1 μ F +10% 35VDCW	
A4C2	0150-0121	C:FXD CER 0.1 μ F -20% +80% 50VDCW	
A4C3	0180-0228	C:FXD TA 22 μ F 10% 15VDCW	
A4J1		NOT ASSIGNED	
A4J2		NOT ASSIGNED	
A4J3		NOT ASSIGNED	
A4J4		NOT ASSIGNED	
A4J5		NOT ASSIGNED	
A4J6	1250-0257	CONNECTOR:RF FEMALE	
A4L1	9170-0029	MAGNETIC CORE:BEAD FERRITE	
A4L2	9140-0098	COIL:FXD RF 2.2 μ H 10%	
A4Q1	1854-0091	TRANSISTOR:NPN SILICON	
A4Q2	1854-0332	TRANSISTOR:NPN SILICON	
A4R1	0757-0395	R:FXD MET FLM 56.2 Ω 1% 1/8W	
A4R2	0757-0417	R:FXD MET FLM 562 Ω 1% 1/8W	
A4R3	0698-4431	R:FXD MET FLM 2.05k Ω 1% 1/8W	
A4R4	0757-0159	R:FXD MET FLM 1k Ω 1% 1/8W	
A4R5	0698-3628	R:FXD MET OX 220 Ω 5% 2W	
	1205-0007	MISCELLANEOUS HEAT DISSIPATOR NUT 1 REQ'D	
	1205-0008	HEAT DISSIPATOR BODY 1 REQ'D	
	04342-1223	PLATE	

See list of abbreviations in introduction to this section

Table 6-2. Reference Designation Index (Cont'd)

Reference Designation	Part No.	Description	Note
A5	04342-7705 04342-8705	IMPEDANCE CONVERTER & RF AMPLIFIER ASS'Y BOARD:BLANK PC	
A5C1	0160-2244	C:FXD CER 3pF $\pm 0.25\mu\text{F}$	
A5C2	0180-1735	C:FXD TA 0.22 μF 10% 35VDCW	
A5C3	0180-0376	C:FXD TA 0.47 μF 10% 35VDCW	
A5C4	0160-2259	C:FXD CER 12pF 5%	
A5C5	0180-1745	C:FXD TA 1.5 μF 10% 20VDCW	
A5C6	0160-0128	C:FXD CER 2.2 μF 20% 25VDCW	
A5C7	0160-0128	C:FXD CER 2.2 μF 20% 25VDCW	
A5C8	0160-0128	C:FXD CER 2.2 μF 20% 25VDCW	
A5C9	0160-0155	C:FXD MY 0.0033 μF 10% 200VDCW	
A5C10	0180-0376	C:FXD TA 0.47 μF 10% 35VDCW	
A5C11	0160-0174	C:FXD CER 0.47 μF -20% +80% 25VDCW	
A5C12	0160-0128	C:FXD CER 2.2 μF 20% 25VDCW	
A5C13	0140-0192	C:FXD MICA 68pF 5% 300VDCW	
A5C14	0160-0128	C:FXD CER 2.2 μF 20% 25VDCW	
A5C15	0160-2150	C:FXD MICA 33pF 5% 300VDCW	
A5C16	0121-0147	C:VAR AIR 2.0 - 19.3pF	
A5C17	0160-0128	C:FXD CER 2.2 μF 20% 25VDCW	
A5C18	0180-0376	C:FXD TA 0.47 μF 10% 35VDCW	
A5C19	0160-0174	C:FXD CER 0.47 μF -20% +80% 25VDCW	
A5C20	0150-0121	C:FXD CER 0.1 μF -20% +80% 50VDCW	
A5C21	0180-0376	C:FXD TA 0.47 μF 10% 35VDCW	
A5C22	0180-0376	C:FXD TA 0.47 μF 10% 35VDCW	
A5C23	0180-0291	C:FXD TA 1 μF 10% 35VDCW	
A5CR1	1901-0025	SEMICON DEVICE:DIODE SILICON	
A5CR2	1910-0016	SEMICON DEVICE:DIODE GERMANIUM	
A5CR3	1910-0016	SEMICON DEVICE:DIODE GERMANIUM	
A5CR4	1910-0016	SEMICON DEVICE:DIODE GERMANIUM	
A5CR5	1910-0016	SEMICON DEVICE:DIODE GERMANIUM	
A5CR6	1910-0016	SEMICON DEVICE:DIODE GERMANIUM	
A5L1		NOT ASSIGNED	
A5L2	9140-0179	COIL:FXD RF 22 μH 10%	
A5Q1	1855-0022	TRANSISTOR:FIELD EFFECT N-CHANNEL	
A5Q2	1853-0015	TRANSISTOR:PNP SILICON 2N3640	
A5Q3	1854-0023	TRANSISTOR:NPN SILICON	
A5Q4	1854-0092	TRANSISTOR:NPN SILICON 2N3563	
A5Q5	1854-0296	TRANSISTOR:NPN SILICON MPS6543	
A5Q6	1854-0092	TRANSISTOR:NPN SILICON 2N3563	
A5Q7	1853-0015	TRANSISTOR:PNP SILICON 2N3640	
A5Q8	1854-0233	TRANSISTOR:NPN SILICON 2N3866	
A5Q9	1854-0091	TRANSISTOR:NPN SILICON	

See list of abbreviations in introduction to this section

Table 6-2. Reference Designation Index (Cont'd)

Reference Designation	Part No.	Description	Note
A5R1	0757-0346	R:FXD MET FLM 10 Ω 1% 1/8W	
A5R2	0698-3151	R:FXD MET FLM 2.87k Ω 1% 1/8W	
A5R3	0757-0465	R:FXD MET FLM 100k Ω 1% 1/8W	
A5R4	0757-0465	R:FXD MET FLM 100k Ω 1% 1/8W	
A5R5	0698-2335	R:FXD C FLM 28.1M Ω 0.5% 1W	
A5R6	0698-0085	R:FXD MET FLM 2.61k Ω 1% 1/8W	
A5R7	0698-3155	R:FXD MET FLM 4.64k Ω 1% 1/8W	
A5R8	0757-0401	R:FXD MET FLM 100 Ω 1% 1/8W	
A5R9	0757-0441	R:FXD MET FLM 8.25k Ω 1% 1/8W	
A5R10	0698-3150	R:FXD MET FLM 2.37k Ω 1% 1/8W	
A5R11	0698-3439	R:FXD MET FLM 178 Ω 1% 1/8W	
A5R12	0698-0089	R:FXD MET FLM 1.78k Ω 1% 1/2W	
A5R13	0698-3430	R:FXD MET FLM 21.5 Ω 1% 1/8W	
A5R14	0757-0346	R:FXD MET FLM 10 Ω 1% 1/8W	
A5R15	0698-3152	R:FXD MET FLM 3.48k Ω 1% 1/8W	
A5R16	0757-0438	R:FXD MET FLM 5.11k Ω 1% 1/8W	
A5R17	0757-0440	R:FXD MET FLM 7.5k Ω 1% 1/8W	
A5R18	0757-0438	R:FXD MET FLM 5.11k Ω 1% 1/8W	
A5R19	0757-0422	R:FXD MET FLM 909 Ω 1% 1/8W	
A5R20	0757-0398	R:FXD MET FLM 75 Ω 1% 1/8W	
A5R21	0757-0294	R:FXD MET FLM 17.8 Ω 1% 1/8W	
A5R22	0698-4422	R:FXD MET FLM 1.27k Ω 1% 1/8W	
A5R23	0757-0346	R:FXD MET FLM 10 Ω 1% 1/8W	
A5R24	0757-0405	R:FXD MET FLM 162 Ω 1% 1/8W	
A5R25	0698-3409	R:FXD MET FLM 2.37k Ω 1% 1/2W	
A5R26	0757-0439	R:FXD MET FLM 6.81k Ω 1% 1/8W	
A5R27	0757-0290	R:FXD MET FLM 6.19k Ω 1% 1/8W	
A5R28	0757-0274	R:FXD MET FLM 1.21k Ω 1% 1/8W	
A5R29	0698-3434	R:FXD MET FLM 34.8 Ω 1% 1/8W	
A5R30	0757-0419	R:FXD MET FLM 681 Ω 1% 1/8W	
A5R31	0757-0394	R:FXD MET FLM 51.1 Ω 1% 1/8W	
A5R32	2100-1986	R:VAR MET FLM 1k Ω 10% 1/2W	
A5R33	0698-3430	R:FXD MET FLM 21.5 Ω 1% 1/8W	
A5R34	0698-3700	R:FXD MET FLM 715 Ω 1% 1/8W	
A5R35	0757-0814	R:FXD MET FLM 511 Ω 1% 1/2W	
A5R36	0757-0379	R:FXD MET FLM 12.1 Ω 1% 1/8W	
A5R37	0757-1092	R:FXD MET FLM 287 Ω 1% 1/2W	
A5R38	0757-0346	R:FXD MET FLM 10 Ω 1% 1/8W	
A5R39	0757-0159	R:FXD MET FLM 1k Ω 1% 1/2W	
A5R40	0698-3152	R:FXD MET FLM 3.48k Ω 1% 1/8W	
A5R41	0757-0401	R:FXD MET FLM 100 Ω 1% 1/8W	
A5R43	2100-0558	R:VAR CERMET 20k Ω 10% 1/2W	
A5R44	0698-3429	R:FXD MET FLM 19.6 Ω 1% 1/8W	
A5R45	0698-3429	R:FXD MET FLM 19.6 Ω 1% 1/8W	
	0340-0008	MISCELLANEOUS INSULATOR-STAND OFF 2 REQ'D	
	9170-0029	BEAD FERRITE	

See list of abbreviations in introduction to this section

Table 6-2. Reference Designation Index (Cont'd)

Reference Designation	Part No.	Description	Note
A6	04342-7706 04342-8706	DC AMPLIFIER ASS'Y BOARD:BLANK PC	
A6C1	0160-0127	C:FXD CER 1 μ F 20% 25VDCW	
A6C2	0180-0116	C:FXD TA 6.8 μ F 10% 35VDCW	
A6C3	0180-0116	C:FXD TA 6.8 μ F 10% 35VDCW	
A6C4	0180-0197	C:FXD TA 2.2 μ F 10% 20VDCW	
A6C5	0180-0197	C:FXD TA 2.2 μ F 10% 20VDCW	
A6CR1	1901-0025	SEMICON DEVICE:DIODE SILICON	
A6CR2	1902-3097	SEMICON DEVICE:DIODE BREAKDOWN 5.23V 2% 400mW	
A6CR3	1902-3097	SEMICON DEVICE:DIODE BREAKDOWN 5.23V 2% 400mW	
A6L1	9140-0179	COIL:FXD RF 22 μ H 10%	
A6L2	9140-0179	COIL:FXD RF 22 μ H 10%	
A6Q1	1855-0081	TRANSISTOR:FIELD EFFECT N-CHANNEL	
A6Q2	1855-0049	TRANSISTOR:FIELD EFFECT N-CHANNEL DUAL	
A6Q3	1853-0010	TRANSISTOR:PNP SILICON	
A6Q4	1854-0023	TRANSISTOR:NPN SILICON	
A6Q5	1853-0010	TRANSISTOR:PNP SILICON	
A6R1	0757-0442	R:FXD MET FLM 10k Ω 1% 1/8W	
A6R2	2100-3356	R:VAR CERMET 200k Ω 10% 1/2W	
A6R3	0757-0401	R:FXD MET FLM 100 Ω 1% 1/8W	
A6R4	2100-3351	R:VAR CERMET 500 Ω 10% 1/2W	
A6R5	0757-0439	R:FXD MET FLM 6.81k Ω 1% 1/8W	
A6R6	2100-3352	R:VAR CERMET 1k Ω 10% 1/2W	
A6R7	0698-3151	R:FXD MET FLM 2.87k Ω 1% 1/8W	
A6R8	0757-0416	R:FXD MET FLM 511 Ω 1% 1/8W	
A6R9	0757-0482	R:FXD MET FLM 511k Ω 1% 1/8W	
A6R10	0757-0401	R:FXD MET FLM 100 Ω 1% 1/8W	
A6R11	0757-0462	R:FXD MET FLM 75k Ω 1% 1/8W	
A6R12	0757-0442	R:FXD MET FLM 10k Ω 1% 1/8W	
A6R13	0757-0280	R:FXD MET FLM 1k Ω 1% 1/8W	
A6R14	0757-0439	R:FXD MET FLM 6.81k Ω 1% 1/8W	
A6R15	0757-0419	R:FXD MET FLM 681 Ω 1% 1/8W	
A6R16	0698-3136	R:FXD MET FLM 17.8k Ω 1% 1/8W	
A6R17	0757-0438	R:FXD MET FLM 5.11k Ω 1% 1/8W	
A6R18	0757-0419	R:FXD MET FLM 681 Ω 1% 1/8W	
A6R19	0757-0442	R:FXD MET FLM 10k Ω 1% 1/8W	
A6R20	0698-4037	R:FXD MET FLM 46.4 Ω 1% 1/8W	

See list of abbreviations in introduction to this section

Table 6-2, Reference Designation Index (Cont'd)

Reference Designation	Part No.	Description	Note
A6R21 A6R22 A6R23 A6R24 A6R25	2100-3349 0757-0462 0757-0401 0698-0083 0698-0083	R:VAR CERMET 100Ω 10% 1/2W R:FXD MET FLM 75kΩ 1% 1/8W R:FXD MET FLM 100Ω 1% 1/8W R:FXD MET FLM 1.96kΩ 1% 1/8W R:FXD MET FLM 1.96kΩ 1% 1/8W	
A6R26 A6R27 A6R28 A6R29	0698-4431 0698-0083 0698-0084 0757-0200 0757-0200 0757-0273	R:FXD MET FLM 2.05kΩ 1% 1/8W R:FXD 1.96kΩ 10% 1/8W R:FXD 2.15kΩ 10% 1/8W R:FXD MET FLM 5.62kΩ 1% 1/8W R:FXD MET FLM 5.62kΩ 1% 1/8W R:FXD MET FLM 3.01kΩ 1% 1/8W	
	5040-5117	MISCELLANEOUS EXTRACTOR:BLUE 2 REQ'D	

See list of abbreviations in introduction to this section

Table 6-2. Reference Designation Index (Cont'd)

Reference Designation	Part No.	Description	Note
A7	04342-7707 04342-8707	Q-LIMIT SELECTOR ASS'Y BOARD:BLANK PC	
A7C1	0160-2964	C:FXD CER 0.01 μ F -20% +80%	
A7C2	0150-0121	C:FXD CER 0.1 μ F -20% +80%	
A7C3	0160-0155	C:FXD MY 0.0033 μ F 10% 200VDCW	
A7C4	0180-0373	C:FXD TA 0.68 μ F 10% 35VDCW	
A7C5	0180-0116	C:FXD TA 6.8 μ F 10% 35VDCW	
A7C6	0160-0128	C:FXD CER 2.2 μ F 20% 25VDCW	
A7C7	0160-0155	C:FXD MY 0.0033 μ F 10% 200VDCW	
A7C8	0180-0116	C:FXD TA 6.8 μ F 10% 35VDCW	
A7CR1	1902-3059	SEMICON DEVICE:DIODE BREAKDOWN 3.83V 5% 400mW	
A7CR2	1902-3234	SEMICON DEVICE:DIODE BREAKDOWN 19.6V 5% 400mW	
A7CR3	1910-0016	SEMICON DEVICE:DIODE GERMANIUM	
A7CR4	1902-3149	SEMICON DEVICE:DIODE BREAKDOWN 9.09V 5% 400mW	
A7CR5	1901-0025	SEMICON DEVICE:DIODE SILICON	
A7CR6	1901-0025	SEMICON DEVICE:DIODE SILICON	
A7K1	0490-0214	RELAY REED:DPST 8.7 - 22VDCW 0.5A, 15VA SRG-13A	
A7L1	9140-0210	COIL:FXD RF 100 μ H 5%	
A7L2	9140-0210	COIL:FXD RF 100 μ H 5%	
A7Q1	1855-0081	TRANSISTOR:FIELD EFFECT N-CHANNEL	
A7Q2	1855-0081	TRANSISTOR:FIELD EFFECT N-CHANNEL	
A7Q3	1854-0071	TRANSISTOR:NPN SILICON 2N3391	
A7Q4	1854-0071	TRANSISTOR:NPN SILICON 2N3391	
A7Q5	1854-0071	TRANSISTOR:NPN SILICON 2N3391	
A7Q6	1854-0071	TRANSISTOR:NPN SILICON 2N3391	
A7Q7	1854-0298	TRANSISTOR:NPN SILICON	
A7Q8	1854-0071	TRANSISTOR:NPN SILICON 2N3391	
A7Q9	1854-0071	TRANSISTOR:NPN SILICON 2N3391	
A7R1	0757-1094	R:FXD MET FLM 1.47k Ω 1% 1/8W	
A7R2	0757-0280	R:FXD MET FLM 1k Ω 1% 1/8W	
A7R3	2100-3353	R:VAR CERMET 20k Ω 10% 1/2W	
A7R4	0698-3157	R:FXD MET FLM 19.6k Ω 1% 1/8W	
A7R5	0757-0199	R:FXD MET FLM 21.5k Ω 1% 1/8W	
A7R6	0698-3245	R:FXD MET FLM 20.5k Ω 1% 1/8W	
A7R7	2100-3356	R:VAR CERMET 200k Ω 10% 1/2W	
A7R8	0698-3445	R:FXD MET FLM 348 Ω 1% 1/8W	
A7R9	0698-3429	R:FXD MET FLM 19.6 Ω 1% 1/8W	
A7R10	0757-0458	R:FXD MET FLM 51.1k Ω 1% 1/8W	

See list of abbreviations in introduction to this section

Table 6-2. Reference Designation Index (Cont'd)

Reference Designation	Part No.	Description	Note
A7R11	0698-4207	R:FXD MET FLM 44.2kΩ 1% 1/8W	
A7R12	0757-0443	R:FXD MET FLM 11kΩ 1% 1/8W	
A7R13	0757-1094	R:FXD MET FLM 1.47kΩ 1% 1/8W	
A7R14	0757-0409	R:FXD MET FLM 274Ω 1% 1/8W	
A7R15	0757-0440	R:FXD MET FLM 7.5kΩ 1% 1/8W	
A7R16	0698-3136	R:FXD MET FLM 17.8kΩ 1% 1/8W	
A7R17	0757-0433	R:FXD MET FLM 5.11kΩ 1% 1/8W	
A7R18	0757-0441	R:FXD MET FLM 8.25kΩ 1% 1/8W	
A7R19	0757-0289	R:FXD MET FLM 13.3kΩ 1% 1/8W	
A7R20	0698-3460	R:FXD MET FLM 422kΩ 1% 1/8W	
A7R21	0698-3158	R:FXD MET FLM 23.7kΩ 1% 1/8W	
A7R22	0757-0433	R:FXD MET FLM 3.32kΩ 1% 1/8W	
A7R23	0757-0279	R:FXD MET FLM 3.16kΩ 1% 1/8W	
A7R24	0690-6811	R:FXD COMP 680Ω 10% 1W	
A7R25	0698-3158	R:FXD MET FLM 23.7kΩ 1% 1/8W	
A7R26	0698-3160	R:FXD MET FLM 31.6kΩ 1% 1/8W	
A7R27	0757-0346	R:FXD MET FLM 10Ω 1% 1/8W	
A7R28	0698-3160	R:FXD MET FLM 31.6kΩ 1% 1/8W	
A7R29	0757-0416	R:FXD MET FLM 511Ω 1% 1/8W	
A7R30	0698-3136	R:FXD MET FLM 17.8kΩ 1% 1/8W	
A7R31	0698-3400	R:FXD MET OX 147Ω 1% 1/2W	
	5040-5118	MISCELLANEOUS EXTRACTOR:VIOLET 2 REQ'D	

See list of abbreviations in introduction to this section

Table 6-2. Reference Designation Index (Cont'd)

Reference Designation	Part No.	Description	Note
A8	04342-7708 04342-8708	POWER SUPPLY & ALC AMPLIFIER ASS'Y BOARD:BLANK PC	
A8C1	0150-0121	C:FXD CER 0.1 μ F -20% +80% 50VDCW	
A8C2	0180-0291	C:FXD TA 1 μ F 10% 35VDCW	
A8C3	0180-0097	C:FXD TA 47 μ F 10% 35VDCW	
A8C4	0150-0121	C:FXD CER 0.1 μ F -20% +80% 50VDCW	
A8C5	0180-0291	C:FXD TA 1 μ F 10% 35VDCW	
A8C6	0180-0097	C:FXD TA 47 μ F 10% 35VDCW	
A8C7	0180-0982	C:FXD ELECT 1 μ F -10% +100% 250VDCW	
A8C8	0180-0982	C:FXD ELECT 1 μ F -10% +100% 250VDCW	
A8C9	0180-1735	C:FXD TA 0.22 μ F 10% 35VDCW	
A8C10	0180-1735	C:FXD TA 0.22 μ F 10% 35VDCW	
A8CR1	1901-0026	SEMICON DEVICE:DIODE SILICON	
A8CR2	1901-0026	SEMICON DEVICE:DIODE SILICON	
A8CR3	1901-0026	SEMICON DEVICE:DIODE SILICON	
A8CR4	1901-0026	SEMICON DEVICE:DIODE SILICON	
A8CR5	1902-0041	SEMICON DEVICE:DIODE BREAKDOWN 5.11V 5% 400mW	
A8CR6	1901-0025	SEMICON DEVICE:DIODE SILICON	
A8CR7	1901-0025	SEMICON DEVICE:DIODE SILICON	
A8CR8	1901-0025	SEMICON DEVICE:DIODE SILICON	
A8CR9	1901-0025	SEMICON DEVICE:DIODE SILICON	
A8CR10	1901-0026	SEMICON DEVICE:DIODE SILICON	
A8CR11	1901-0026	SEMICON DEVICE:DIODE SILICON	
A8CR12	1901-0026	SEMICON DEVICE:DIODE SILICON	
A8CR13	1901-0026	SEMICON DEVICE:DIODE SILICON	
A8CR14	1901-0025	SEMICON DEVICE:DIODE SILICON	
A8CR15	1901-0025	SEMICON DEVICE:DIODE SILICON	
A8CR16	1901-0025	SEMICON DEVICE:DIODE SILICON	
A8CR17	1910-0016	SEMICON DEVICE:DIODE GERMANIUM	
A8CR18	1902-0041	SEMICON DEVICE:DIODE BREAKDOWN 5.11V 5% 400mW	
A8CR19	1901-0025	SEMICON DEVICE:DIODE SILICON	
A8CR20	1901-0026	SEMICON DEVICE:DIODE SILICON	
A8CR21	1901-0026	SEMICON DEVICE:DIODE SILICON	
A8CR22	1902-3182	SEMICON DEVICE:DIODE BREAKDOWN 12.1V 5% 400mW	
A8Q1	1854-0039	TRANSISTOR:SILICON NPN 2N3053	
A8Q2	1854-0071	TRANSISTOR:SILICON NPN 2N3391	
A8Q3	1854-0215	TRANSISTOR:SILICON NPN 2N3904	
A8Q4	1854-0215	TRANSISTOR:SILICON NPN 2N3904	
A8Q5	1854-0071	TRANSISTOR:SILICON NPN 2N3391	

See list of abbreviations in introduction to this section

Table 6-2. Reference Designation Index (Cont'd)

Reference Designation	Part No.	Description	Note
A8Q6	1854-0039	TRANSISTOR:SILICON NPN 2N3053	
A8Q7	1854-0071	TRANSISTOR:SILICON NPN 2N3391	
A8Q8	1854-0071	TRANSISTOR:SILICON NPN 2N3391	
A8Q9	1855-0049	TRANSISTOR:FIELD EFFECT N-CHANNEL DUAL	
A8Q10	1853-0036	TRANSISTOR:SILICON PNP 2N3906	
A8Q11	1854-0071	TRANSISTOR:SILICON NPN 2N3391	
A8Q12	1853-0036	TRANSISTOR:SILICON PNP 2N3906	
A8Q13	1853-0036	TRANSISTOR:SILICON PNP 2N3906	
A8R1	0813-0029	R:FXD WW 1 Ω 10% 3W	
A8R2	0757-0288	R:FXD MET FLM 9.09k Ω 1% 1/8W	
A8R3	0757-0346	R:FXD MET FLM 10 Ω 1% 1/8W	
A8R4	0813-0029	R:FXD WW 1 Ω 10% 3W	
A8R5	0698-0084	R:FXD MET FLM 2.15k Ω 1% 1/8W	
A8R6	0757-0442	R:FXD MET FLM 10k Ω 1% 1/8W	
A8R7	0757-0439	R:FXD MET FLM 6.81k Ω 1% 1/8W	
A8R8	0698-4433	R:FXD MET FLM 2.26k Ω 1% 1/8W	
A8R9	0757-0442	R:FXD MET FLM 10k Ω 1% 1/8W	
A8R10	0757-0442	R:FXD MET FLM 10k Ω 1% 1/8W	
A8R11	0757-0441	R:FXD MET FLM 8.25k Ω 1% 1/8W	
A8R12	2100-3352	R:VAR CERMET 1k Ω 10% 1/2W	
A8R13	0698-4431	R:FXD MET FLM 2.05k Ω 1% 1/8W	
A8R14	0813-0029	R:FXD WW 1 Ω 10% 3W	
A8R15	0698-3447	R:FXD MET FLM 422 Ω 1% 1/8W	
A8R16	0698-0084	R:FXD MET FLM 2.15k Ω 1% 1/8W	
A8R17	0698-4020	R:FXD MET FLM 9.53k Ω 1% 1/8W	
A8R18	0698-3158	R:FXD MET FLM 23.7k Ω 1% 1/8W	
A8R19	0757-0442	R:FXD MET FLM 10k Ω 1% 1/8W	
A8R20	0698-3156	R:FXD MET FLM 14.7k Ω 1% 1/8W	
A8R21	2100-3352	R:VAR CERMET 1k Ω 10% 1/2W	
A8R22	0698-4020	R:FXD MET FLM 9.53k Ω 1% 1/8W	
A8R23	0813-0029	R:FXD WW 1 Ω 10% 3W	
A8R24	0698-3412	R:FXD MET FLM 3.83k Ω 1% 1/2W	
A8R25	0698-4477	R:FXD MET FLM 10.5k Ω 1% 1/8W	
A8R26	2100-3352	R:VAR CERMET 1k Ω 10% 1/2W	
A8R27	0757-0401	R:FXD MET FLM 100 Ω 1% 1/8W	
A8R28	0683-1055	R:FXD COMP 1M Ω 5% 1/4W	
A8R29	0698-4511	R:FXD MET FLM 86.6k Ω 1% 1/8W	
A8R30	0757-0453	R:FXD MET FLM 30.1k Ω 1% 1/8W	
A8R31	0757-0470	R:FXD MET FLM 162k Ω 1% 1/8W	
A8R32	0757-0442	R:FXD MET FLM 10k Ω 1% 1/8W	
A8R33	0757-0280	R:FXD MET FLM 1k Ω 1% 1/8W	
A8R34	0757-0444	R:FXD MET FLM 12.1k Ω 1% 1/8W	
A8R35	0757-0442	R:FXD MET FLM 10k Ω 1% 1/8W	

See list of abbreviations in introduction to this section

Table 6-2, Reference Designation Index (Cont'd)

Reference Designation	Part No.	Description	Note
A8R36	0757-0280	R:FXD MET FLM 1k Ω 1% 1/8W	
A8R37	0757-0200	R:FXD MET FLM 5.62k Ω 1% 1/8W	
A8R38	0757-0453	R:FXD MET FLM 30.1k Ω 1% 1/8W	
A8R39	0757-0438	R:FXD MET FLM 5.11k Ω 1% 1/8W	
A8R40	0698-3157	R:FXD MET FLM 19.6k Ω 1% 1/8W	
A8R41	0683-1055	R:FXD COMP 1M Ω 5% 1/4W	
A8R42	0757-0482	R:FXD MET FLM 511k Ω 1% 1/8W	
A8R43	0757-0461	R:FXD MET FLM 68.1k Ω 1% 1/8W	
	5040-4592	MISCELLANEOUS EXTRACTOR:GRAY 2 REQ'D	
A9		NOT ASSIGNED	
A10	04342-7710 04342-8710	FREQUENCY MULTIPLIER AND OVER LIMIT INDICATOR ASS'Y BOARD:BLANK PC	
A10DS1	2140-0037	LAMP:INCD 28V 0.04A	
A10DS2	2140-0037	LAMP:INCD 28V 0.04A	
A10DS3	2140-0037	LAMP:INCD 28V 0.04A	
A10DS4	2140-0037	LAMP:INCD 28V 0.04A	
A10DS5	2140-0037	LAMP:INCD 28V 0.04A	
A10R1	0698-3402	R:FXD MET FLM 316 Ω 1% 1/2W	
	04342-5022	MISCELLANEOUS SEPARATOR:LAMP	
A11	04342-7711 04342-8711	METER SCALE INDICATOR ASS'Y BOARD:BLANK PC	
A11DS1	2140-0123	LAMP:NEON	
A11DS2	2140-0123	LAMP:NEON	
A11DS3	2140-0123	LAMP:NEON	
A11DS4	2140-0123	LAMP:NEON	
	5040-3313	MISCELLANEOUS HOLDER:LAMP	

See list of abbreviations in introduction to this section

Table 6-2. Reference Designation Index (Cont'd)

Reference Designation	Part No.	Description	Note
C1a	0160-3202	C:FXD CER 1800pF $\pm 20\%$ 3000VDCW	
C1b	0160-3202	C:FXD CER 1800pF $\pm 20\%$ 3000VDCW	
C2	0180-0056	C:FXD ELECT 1000 μ F -10% +100% 50VDCW	
C3	0180-0056	C:FXD ELECT 1000 μ F -10% +100% 50VDCW	
DS1	2140-0037	LAMP:INCD 28V 0.04A	
DS2	2140-0037	LAMP:INCD 28V 0.04A	
F1	2110-0339	FUSE:0.6A 250V SLOW BLOW	
	2110-0044	FUSE:0.3A 250V SLOW BLOW	
J1	1250-0083	CONNECTOR:BNC FEMALE	
J2	1250-0083	CONNECTOR:BNC FEMALE	
J3	1251-2357	CONNECTOR:POWER 3-PIN MALE	
L1	9140-0136	COIL:FXD 22 μ H $\pm 10\%$ 1.33A	
L2	9140-0136	COIL:FXD 22 μ H $\pm 10\%$ 1.33A	
M1	1120-0762	METER:1mA SPEC	
P1		NOT ASSIGNED	
P2		NOT ASSIGNED	
P3	1250-0052	CONNECTOR:BNC MALE PART OF W1	
	1250-0050	NUT:RF CONNECTOR PART OF P3	
	1250-0089	CONTACT:RF CONNECTOR PART OF P3	
P4	1250-0872	CONNECTOR:RF PART OF W1	
P5	1250-0872	CONNECTOR:RF PART OF W2	
P6	1250-0872	CONNECTOR:RF PART OF W2	
Q1	1854-0063	TRANSISTOR:NPN SILICON	
Q2	1854-0063	TRANSISTOR:NPN SILICON	
R1	0698-3400	R:FXD MET FLM 147 Ω 1% 1/2W	
R2	2100-0732	R:VAR COMP 500 Ω 10% 2.25W	
R3	2100-1251	R:VAR COMP 200 Ω 10% WITH R4	
R4		R:VAR COMP 1k Ω 10%	
		NOT SEPARATELY REPLACEABLE PART OF R3	
R5	2100-0006	R:VAR WW 5k Ω 10% 2W	
S1	3101-0011	SWITCH:SLIDE DPDT	
S2	3101-2216	SWITCH:PUSH BUTTON	
S3	3101-1234	SWITCH:SLIDE DPDT	

See list of abbreviations in introduction to this section

Table 6-2. Reference Designation Index (Cont'd)

Reference Designation	Part No.	Description	Note
T1	9100-0779	TRANSFORMER:POWER	
W1	04342-7602	CABLE ASS'Y:COAXIAL INCLUDING P3 AND P4	
W2	04342-7603	CABLE ASS'Y:COAXIAL INCLUDING P5 AND P6	
W3	8120-1348	CABLE ASS'Y:POWER CORD	
XA1		NOT ASSIGNED	
XA2		NOT ASSIGNED	
XA3		NOT ASSIGNED	
XA4		NOT ASSIGNED	
XA5		NOT ASSIGNED	
XA6	1251-0135	CONNECTOR:PRINTED CIRCUIT 15-CONTACT	
XA7	1251-0135	CONNECTOR:PRINTED CIRCUIT 15-CONTACT	
XA8	1251-0159	CONNECTOR:PRINTED CIRCUIT 30-CONTACT	
XF1	1400-0084	FUSE HOLDER:EXTRACTOR POST TYPE	
XQ1	1200-0041	SOCKET:TRANSISTOR	
XQ2	1200-0041	SOCKET:TRANSISTOR	
		MISCELLANEOUS	
	5060-4940	EXTENDER:PC BOARD 30-CONTACT	
	5060-0651	EXTENDER:PC BOARD 12-CONTACT	
	5060-4004	FRAME:SIDE 2 REQ'D	
	04342-1149	PANEL ASS'Y:FRONT	
	04342-1310	PANEL:BLACK FREQUENCY DIAL	
	04342-1311	PANEL:BLACK CAPACITOR DIAL	
	04342-1024	PANEL:REAR	
	04342-1128	COVER ASS'Y:TOP	
	04342-1127	COVER:BOTTOM	
	5000-4167	COVER:SIDE A 2 REQ'D	
	5000-4168	COVER:SIDE B 2 REQ'D	
	0370-0134	KNOB:ROUND RED 1 ARROW	
	0370-0133	KNOB:SKIRTED BLACK 1 ARROW	
	0370-0290	KNOB:SKIRTED BLACK 1 ARROW CONCENTRIC	
	0370-1802	PUSHBUTTON	
	04342-5020	KNOB:THUMB WHEEL BLACK 3 REQ'D	
	04342-3037	HANDLE ASS'Y	
	5040-0447	FOOT:REAR 4 REQ'D	
	5060-0767	FOOT ASS'Y:FULL MODULE 4 REQ'D	
	7120-0480	PLATE:SERIAL NUMBER	
	04342-3261	KNOB:ROUND BLACK 1 ARROW 7 REQ'D	

See list of abbreviations in introduction to this section

Table 6-2. Reference Designation Index (Cont'd)

Reference Designation	Part No.	Description	Note
	04342-1025	BRACKET:FRONT PANEL 2 REQ'D	
	04342-1030	STOPPER:F. C. 2 REQ'D	
	04342-1131	BRACKET:HANDLE H1	
	04342-1132	BRACKET:HANDLE H2	
	04342-1033	BRACKET:HANDLE H3	
	04342-1034	PLATE:HANDLE	
	04342-1035	BRACKET:A5 ASS'Y	
	04342-1036	SHIELD:A5 ASS'Y	
	04342-1042	BRACKET:METER RIGHT	
	04342-1043	BRACKET:METER LEFT	
	04342-1044	BRACKET:FREQUENCY SCALE INDICATOR	
	04342-1051	BELT:FREQUENCY DIAL	
	04342-1052	BELT:MAIN CAPACITOR DIAL	
	04342-1053	BELT:VERNIER CAPACITOR DIAL	
	04342-1054	STOPPER:D	
	04342-1064	SCALE:FREQUENCY DIAL	
	04342-00601	SCALE:MAIN CAPACITOR DIAL	
	04342-00602	SCALE:VERNIER CAPACITOR DIAL	
	04342-1061	DECK:POWER SUPPLY	
	04342-1062	SHIELD:POWER SUPPLY	
	04342-3269	GLASS:CAPACITOR DIAL	
	04342-3033	BOARD:FREQUENCY SCALE INDICATOR	
	04342-3045	GUIDE:OSCILLATOR LEVER	
	04342-3052	SHAFT:FREQUENCY DIAL AND KNOB 2 REQ'D	
	04342-3054	SHAFT:CAPACITOR DIAL AND KNOB 2 REQ'D	
	04342-5023	HOUSE:LAMP FREQUENCY SCALE INDICATOR 2 REQ'D	
	04342-5024	BRACKET:LAMP HOUSE	
	04342-3270	PLATE:TERMINAL INDICATION	
	04342-3271	GUIDE:A5 ASS'Y ADJUSTMENT	
	04342-5027	BRACKET:POWER SWITCH	
	04342-5200	DECK:MAIN	
	04342-7021	LEVER ASS'Y:OSCILLATOR	
	04342-7030	DIAL ASS'Y:FREQUENCY	
	04342-7031	DIAL ASS'Y:MAIN CAPACITOR	
	04342-7032	DIAL ASS'Y:VERNIER CAPACITOR	
	04342-3020	GLASS:FREQUENCY DIAL	
	04342-8541	STRING:KNOB TO DIAL 3 REQ'D	
	04342-8542	STRING:FREQUENCY DIAL TO PULLEY	
	04342-8543	STRING:VERNIER CAPACITOR DIAL TO PULLEY	
	04342-8544	STRING:MAIN CAPACITOR DIAL TO PULLEY	
	1520-0001	PLATE:CAPACITOR MOUNTING 2 REQ'D	
	5040-4528	GUIDE:PC BOARD GRAY 6 REQ'D	
	5040-5125	GUIDE:PC BOARD BLUE	
	5040-5126	GUIDE:PC BOARD VIOLET	
	04342-8551	FILM:FREQUENCY MULTIPLIER INDICATOR	
	04342-8552	FILM:FREQUENCY RANGE SWITCH	
	04342-8553	FILM:Q RANGE SWITCH	
	04342-8554	FILM:FREQUENCY RANGE SWITCH (Option 001)	

See list of abbreviations in introduction to this section

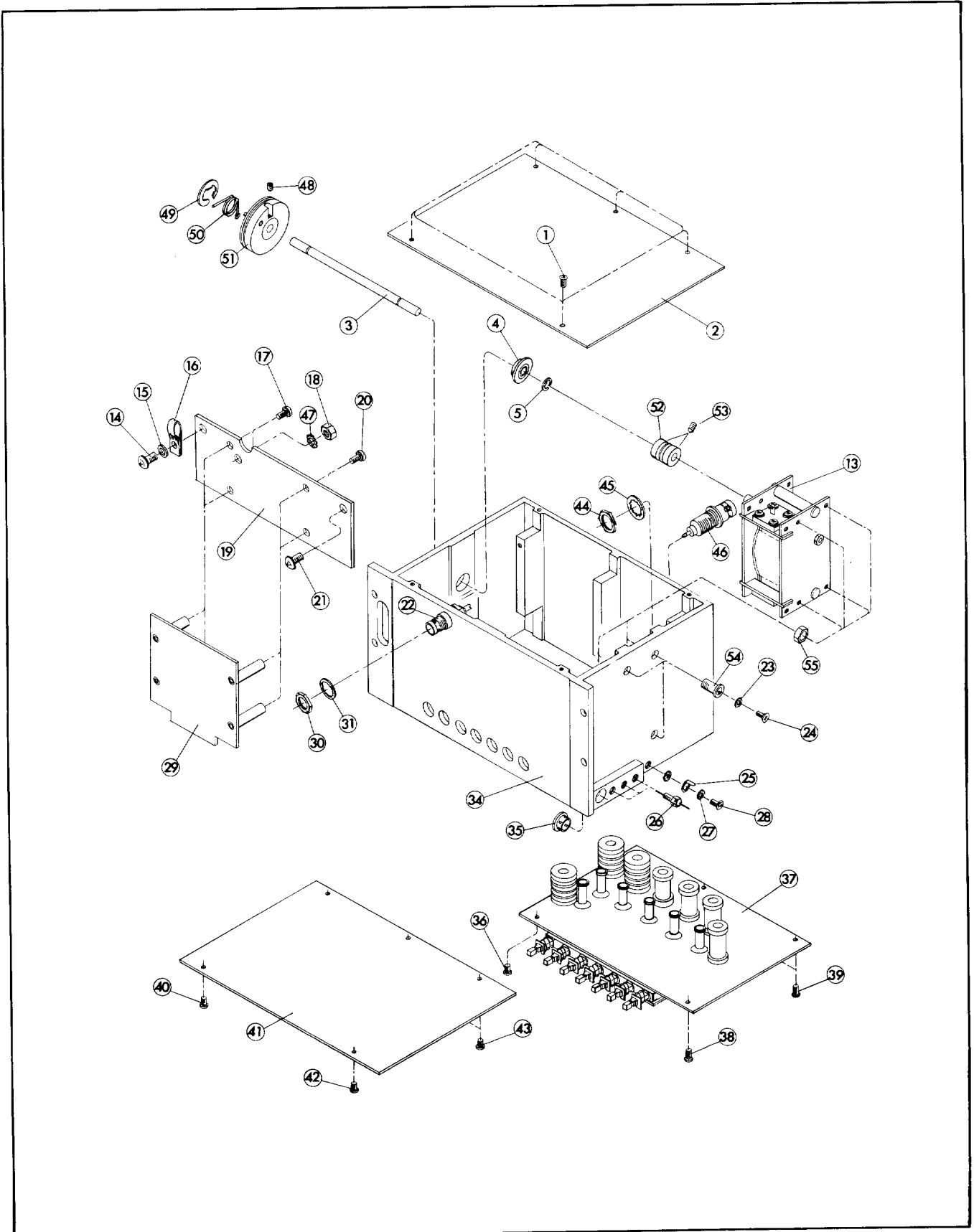

Figure 6-1. Exploded View of Oscillator Ass'y (sheet 1 of 2)

Item No.	Part No.	Q'ty	Description	Note
1	2360-0115	5	SCREW:MACH SST 6-32 X . 312	
2	04342-1070	1	COVER:TOP	
3	04342-3092	1	SHAFT:OSCILLATOR	
4	1410-0307	1	BEARING	
5	0510-0045	2	RING:RET EXT . 188 DIA	
6			NOT ASSIGNED	
7			NOT ASSIGNED	
8			NOT ASSIGNED	
9			NOT ASSIGNED	
10			NOT ASSIGNED	
11			NOT ASSIGNED	
12			NOT ASSIGNED	
13	0121-0232	1	CAPACITOR:AIR	
14	2360-0199	1	SCREW:MACH SST 6-32 X . 438 PH	
15	3050-0066	1	WASHER:BRASS . 147 ID	
16	1400-0325	1	CLAMP:CABLE (NYLON)	
17	2360-0115	2	SCREW:MACH SST 6-32 X . 312	
18	2740-0003	1	NUT:HEX 10-32 X . 375	
19	04342-1073	1	PLATE	
20	2360-0115	2	SCREW:MACH SST 6-32 X . 312	
21	2360-0119	2	SCREW:MACH SST 6-32 X . 438 PH	
22	04342-7601	1	CABLE ASS'Y	
23	2190-0047	4	WASHER:LOCK CNTRSK NO. 6	
24	0570-0237	4	SCREW:MACH BRASS 3mm	
25	0360-0032	1	TERMINAL:LUG	
26	0160-2357	3	C:FXD CER 1000pF	
27	2190-0008	1	WASHER:LOCK EXT PHS . BRZ . 141 ID	
28	2360-0115	1	SCREW:MACH SST 6-32 X . 312	
29	04342-7702	1	PC BOARD:A1A2 ASS'Y	
30	2190-0102	1	WASHER:LOCK BRZ . 475 ID	
31	2950-0035	1	NUT HEX BRASS 15/32-32	
32			NOT ASSIGNED	
33			NOT ASSIGNED	
34	04342-5001	1	CASE:OSCILLATOR (CASTING)	
35	0400-0111	1	GROMMET:SNAP IN	
36	2360-0115	1	SCREW:MACH SST 6-32 X . 312	
37	04342-7731/41	1	PC BOARD:A1A1 ASSEMBLY	
38	2360-0115	1	SCREW:MACH SST 6-32 X . 312	
39	2360-0115	3	SCREW:MACH SST 6-32 X . 312	
40	2360-0115	1	SCREW:MACH SST 6-32 X . 312	
41	04342-1071	1	COVER BOTTOM	
42	2360-0115	1	SCREW:MACH SST 6-32 X . 312	
43	2360-0115	3	SCREW:MACH SST 6-32 X . 312	
44	2950-0035	1	NUT:HEX BRASS 15/32-32	
45	2190-0102	1	WASHER:LOCK BRZ . 475 ID	
46	1250-0314	1	CONNECTOR:BNC FEMALE	
47	2190-0012	1	WASHER:LOCK EXT BRZ	
48	3030-0033	1	SCREW:SET 6-32 X . 188LG HEX SKT . DR	
49	0510-0080	1	RING:RET EXT . 500 DIA E TYPE	
50	04342-8524	1	SPRING:COIL	
51	04342-5035	1	PULLEY:MOLDED	
52	04342-5039	1	COUPLER:FLEXIBLE	
53	3030-0007	4	SCREW:SET #4-40 x . 188LG	
54	04342-3097	3	SPACER	
55	2950-0036	3	NUT:BRASS . 25-28 x . 4375	

Figure 6-1. Exploded View of Oscillator Ass'y (sheet 2 of 2)

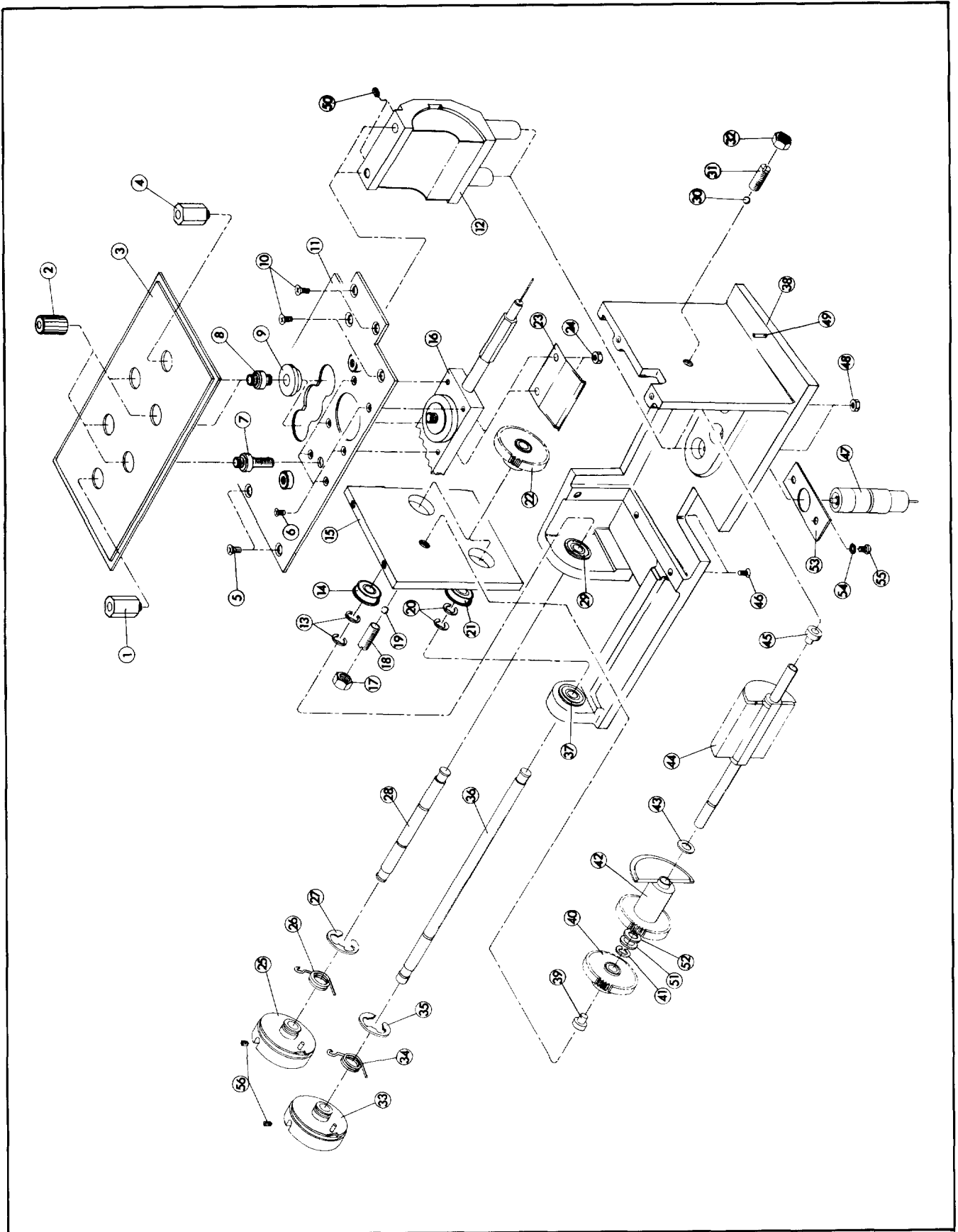

Figure 6-2. Exploded View of Tuning Capacitor Ass'y (sheet 1 of 2)

Item No.	Part No.	Q'ty	Description	Note
1	04342-3267	1	CONNECTOR:HEXAGONAL GROUND LUG	
2	04342-3259	4	CAP:BINDING POST	
3	04342-3256	1	BOARD:TERMINAL TEFLON	
4	04342-3267	1	CONNECTOR:HEXAGONAL GROUND LUG	
5	2360-0185	2	SCREW:MACH SST 6-32 X . 375	
6	0520-0164	6	SCREW:MACH SST 2-56	
7	*	1	CONNECTOR:BINDING POST BODY	
8	*	2	CONNECTOR:BINDING POST BODY	
9	*	2	INSULATOR:BOSS	
10	2360-0185	4	SCREW:MACH SST 6-32 X. 375	
11	*	1	PLATE:TERMINAL	
12	*	1	STATOR ASSEMBLY	
13	0510-0045	1	RING:RET EXT .188 DIA	
14	1410-0307	1	BEARING	
15	*	1	PLATE	
16	*	1	TRANSFORMER ASS'Y:INJECTION	
17	*	1	NUT:HEX P=0.75mm	
18	*	1	SCREW:BRASS P=0.75mm	
19	*	1	BALL:SST	
20	0510-0045	2	RING:RET EXT .188 DIA	
21	1410-0307	1	BEARING	
22	04342-7503	2	GEAR ASS'Y	
23	*	1	BRASH:PH BRZ CHEMICAL Au PLATED	
24	*	2	NUT:HEX SST 6-32 THRD	
25	04342-5035	1	PULLEY:MOLDED	
26	04342-8524	1	SPRING:COIL	
27	0510-0080	1	RING:RET EXT .500 DIA E TYPE	
28	04342-3222	1	SHAFT:MAIN CAPACITOR	
29	1410-0307	1	BEARING	
30	*	1	BALL:SST	
31	*	1	SCREW:BRASS P=0.75mm	
32	*	1	NUT:HEX P=0.75mm	
33	04342-5035	1	PULLEY:MOLDED	
34	04342-8524	1	SPRING:COIL	
35	0510-0080	1	RING:RET EXT .500 DIA E TYPE	
36	04342-3223	1	SHAFT:VERNIER CAPACITOR	
37	1410-0307	1	BEARING	
38	*	1	DECK:CASTING	
39	*	1	INSULATOR:DELRI	
40	*	1	GEAR ASS'Y	
41	*	1	RING:RET EXT .188 DIA E TYPE	
42	*	1	VERNIER CAPACITOR ASS'Y	
43	*	2	WASHER:FLAT PHS. BR3 (SELECTED)	
44	*	1	ROTOR ASS'Y	
45	*	1	INSULATOR:DELRI	
46	*	2	SCREW:MACH SST 6-32 X .500	
47	04342-7205	1	C DIVIDER ASS'Y	
48	*	2	NUT:HEX 10-32 X .375	
49	*	1	PIN	
50	*	2	SCREW:SET	
51	*	1	WASHER:FLAT BRASS	
52	*	1	WASHER:WAVY	
53	*	1	PLATE	
54	*	2	WASHER:LOCK EXT	
55	*	2	SCREW:MACH 6-32 X 3/8	
56	3030-0033	1	SCREW:SET 6-32 X .188 LG HEX SKT .DR	

*: NOT SEPARATELY REPLACEABLE

Figure 6-2. Exploded View of Tuning Capacitor Ass'y (sheet 2 of 2)

Item No.	Part No.	Q'ty	Description	Note
1	0400-0011	2	GROMMET:VINYL . 375 ID	
2	04342-1046	1	COVER:SHIELD	
3	2360-0115	2	SCREW:MACH SST 6-32 X . 312	
4	04342-7513	1	SWITCH ASS'Y:Q RANGE	
5	04342-1045	1	CASE:SHIELD	
6	0624-0077	2	SCREW:TAPPING 4-40 THD	
7	2190-0008	1	WASHER:LOCK EXT PHS. BRZ	
8	2360-0193	1	SCREW:MACH SST 6-32 X . 250	
9	3101-0262	4	SWITCH:PUSHBUTTON; Q RANGE	
10	3101-0261	1	SWITCH:PUSHBUTTON; 4Q RANGE	

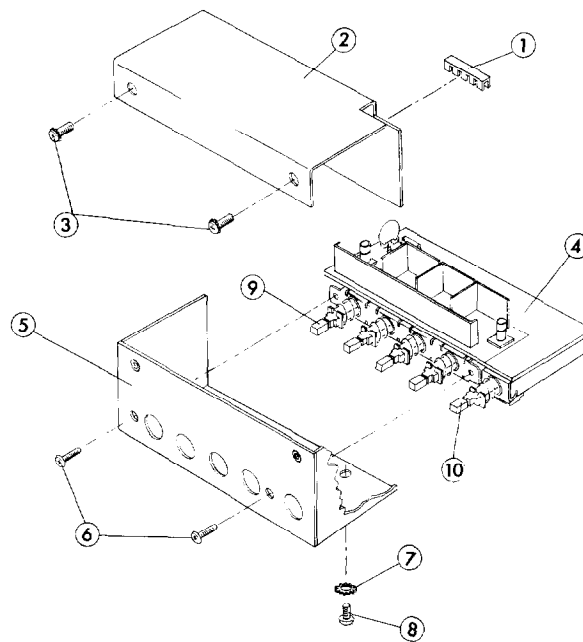

Figure 6-3. Exploded View of Q Range Attenuator Ass'y

Item No.	Part No.	Q'ty	Description	Note
1	04342-3020	1	GLASS:FREQUENCY DIAL	
2	0361-0078	2	RIVET:SEMITUB ALUM . 123 DIA	
3	2200-0166	1	SCREW:MACH SST 4-40 X . 312	
4	0460-0126	2	TAPE:POLYESTER METALIZED	
5	0510-0741	2	BRACKET 90 DEG ANGLE	
6	3050-0067	1	WASHER:FLAT . 375 ID	
7	2360-0113	2	SCREW:MACH SST 6-32 X 125	
8	2190-0018	2	WASHER:LOCK HELICAL	
9	3050-0016	2	WASHER:BRASS . 147 ID	
10	04342-7710	1	PC BOARD ASS'Y	
11	04342-5022	1	SEPARATOR:LAMP P/O ITEM 10	
12	3050-0079	3	WASHER:NYLON . 0937 ID	
13	2190-0223	3	WASHER:SPRING . 0937	
14	0520-0129	3	SCREW:MACH SST 2-56 X . 321	
15	0460-0126	1	TAPE:POLYESTER METALIZED	
16	0610-0001	1	NUT:HEX 2-56 . 188 WD, . 063 THK	
17	2190-0223	1	WASHER:SPRING	
18	3050-0098	1	WASHER:SST . 25 OD, 0313 THK	
19	04342-5023	2	HOUSE:LAMP FREQUENCY SCALE INDICATOR	
20	04342-5024	1	BRACKET:LAMP HOUSE	
21	0520-0183	1	SCREW:MACH SST 2-56 X 1. 25	

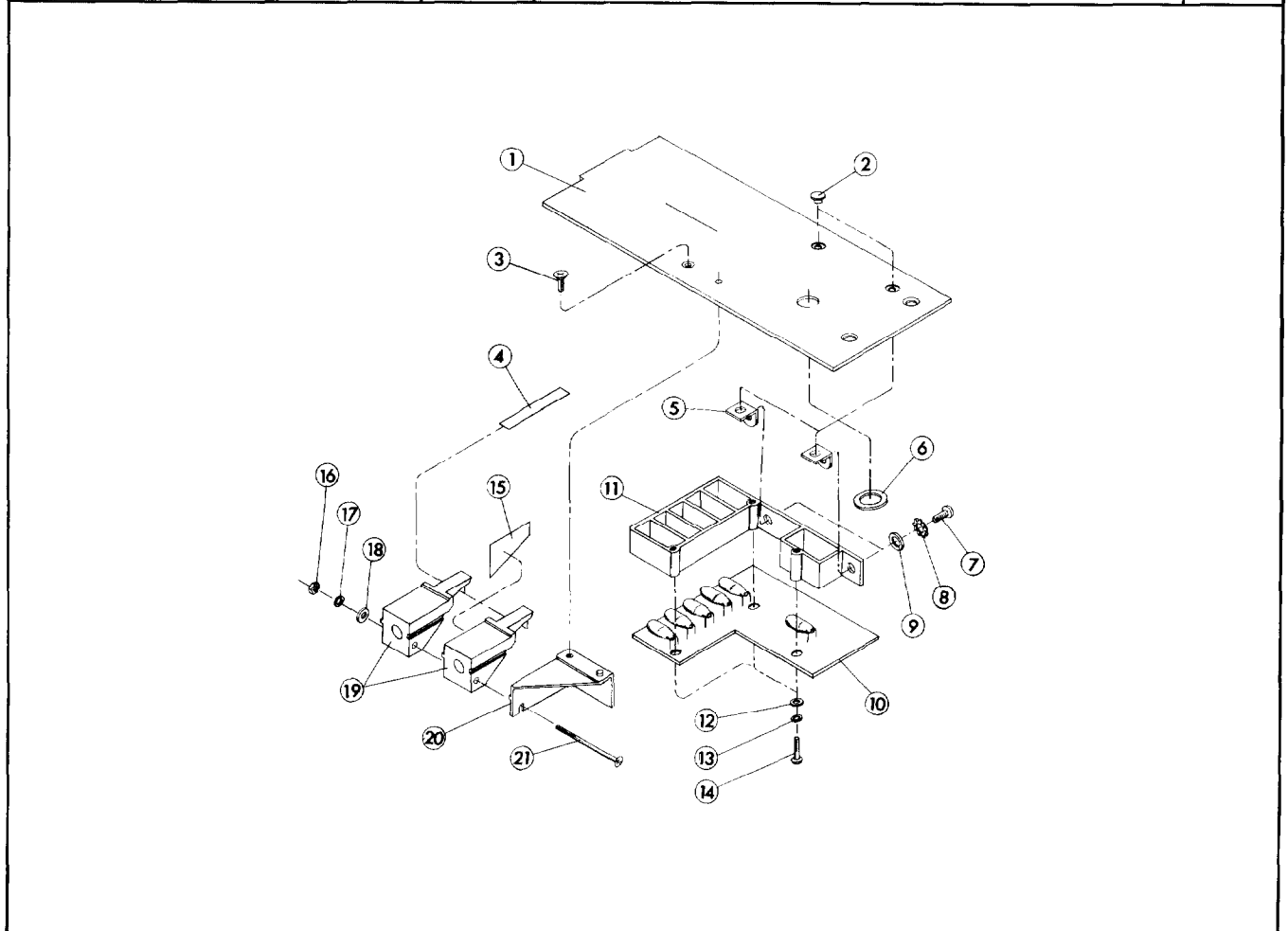

Figure 6-4. Exploded View of Frequency Multiplier, Over Limit Indicator, and Frequency Scale Indicator

Item No.	Part No.	Q'ty	Description	Note
1	04342-5032	1	PULLEY:MOLDED	
2	04342-8522	1	SPRING:COIL	
3	04342-5137	1	DRUM:MOLDED	
4	3050-0016	1	WASHER:FLAT BRASS .147 ID	
5	2360-0121	1	SCREW:MACH SST 6-32 X .500	
6	2360-0121	1	SCREW:MACH SST 6-32 X .500	
7	3050-0016	1	WASHER:FLAT BRASS .147 ID	
8	04342-5138	1	DRUM:MOLDED	
9	04342-8523	1	SPRING:COIL	
10	04342-5033	1	PULLEY:MOLDED	

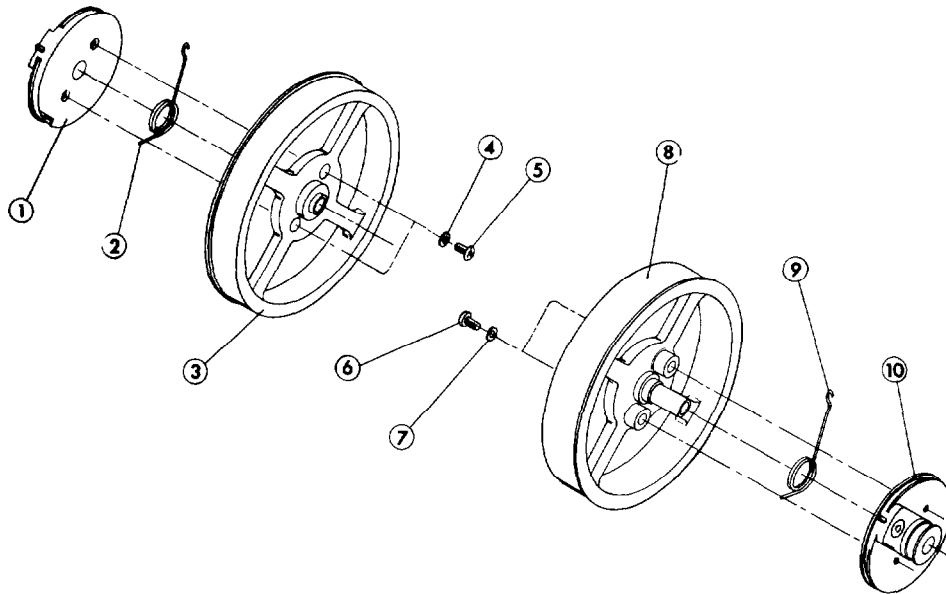

Figure 6-5. Exploded View of Main and Vernier Capacitor Dial Ass'y

Item No.	Part No.	Q'ty	Description	Note
1	0510-0045	1	RING:RET EXT .500 DIA E TYPE	
2	04342-1037	1	ANGLE:L	
3	04342-3044	1	SHAFT:LEVER	
4	0510-0045	7	RING:RET EXT .500 DIA E TYPE	
5	3050-0253	7	WASHER:SPRING STL .250 ID	
6	04342-3043	1	BOSS	
7	04342-3042	6	BOSS	
8	04342-1038	7	LEVER:J	
9	04342-3041	7	BOSS (ACTUATOR)	
10	04342-1039	7	LEVER:L	
11	04342-1037	1	ANGLE:L	
12	0510-0045	1	RING:RET EXT .500 DIA E TYPE	

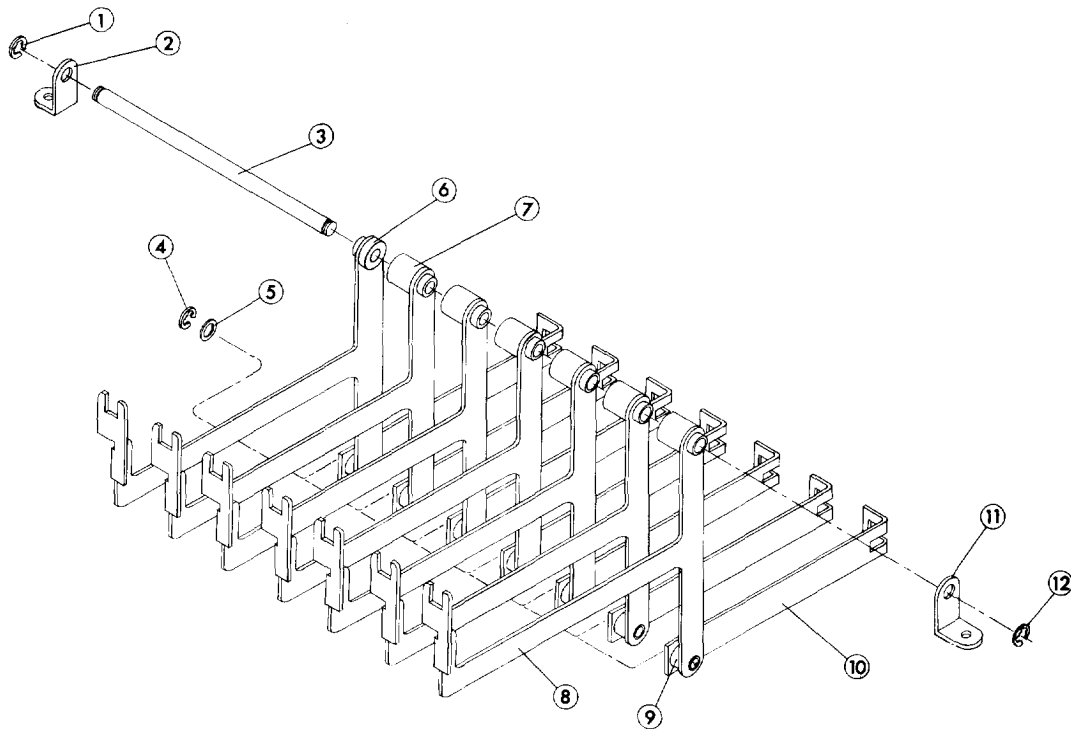

Figure 6-6. Exploded View of Oscillator Lever Ass'y

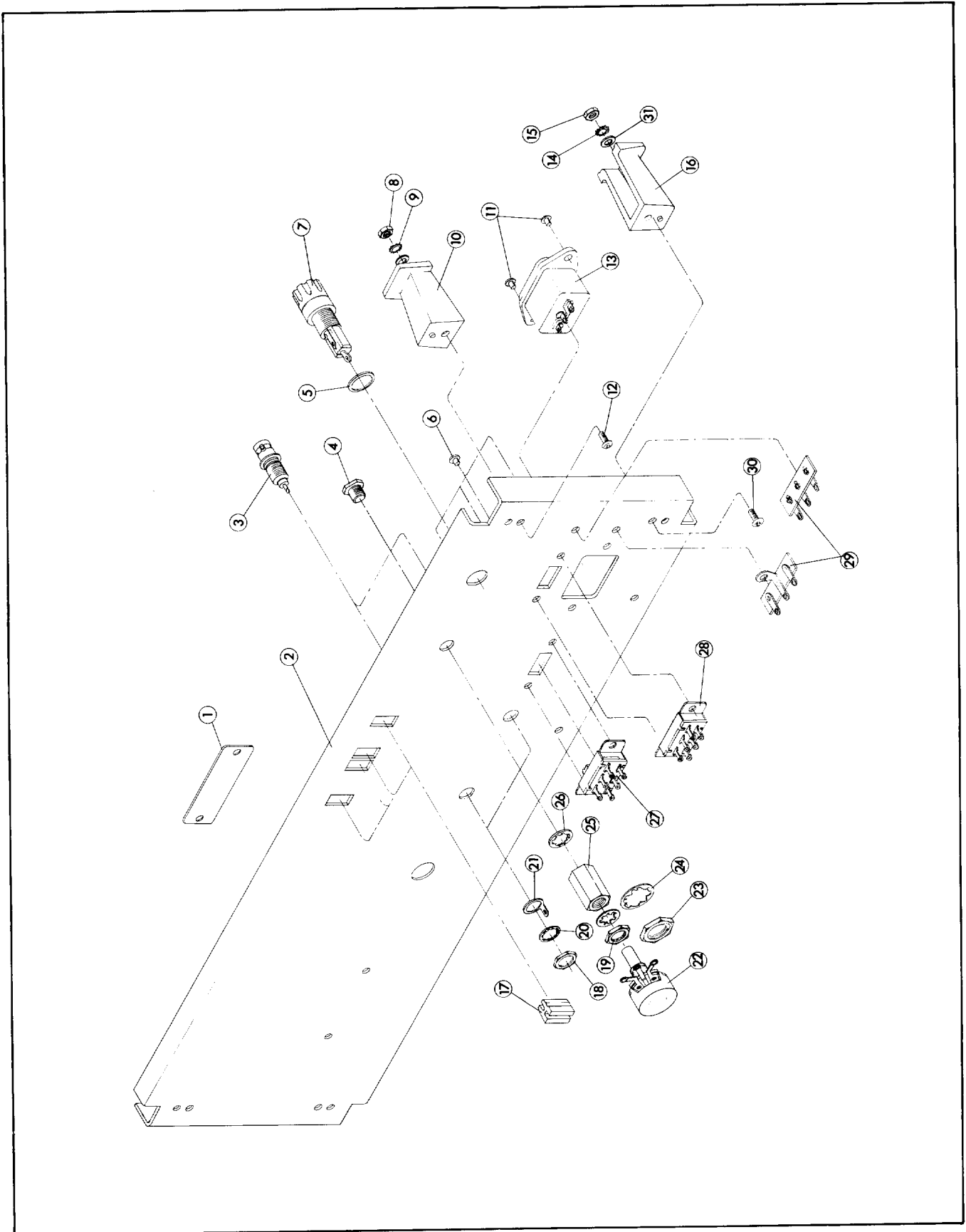

Figure 6-7. Exploded View of Rear Panel (sheet 1 of 2)

Item No.	Part No.	Q'ty	Description	Note
1	7120-0480	1	PLATE:SERIAL NUMBER	
2	04342-1024	1	PANEL:REAR	
3	1251-0083	2	CONNECTOR:BNC FEMALE	
4	1410-0052	1	SCREW:BUSHING	
5	1400-0090	1	WASHER:FUSE HOLDER . 500 ID	
6	0361-0008	4	RIVET SEMITUB ALUM	
7	1400-0084	1	FUSE HOLDER:EXTRACTOR POST TYPE	
8	2420-0001	4	NUT:HEX SNP 6-32 X . 312 WD	
9	2190-0008	4	WASHER:LOCK EXT PH BRZ	
10	5040-0447	2	FOOT:REAR	
11	0361-0011	2	RIVET SEMITUB ALUM 1/8 DIA	
12	2450-0002	2	SCREW:MACH 6-32 X . 25	
13	1251-2357	1	CONNECTOR:POWER 3-PIN MALE	
14	2190-0008	4	WASHER:LOCK EXT PH BNZ	
15	2420-0001	4	NUT:HEX SNP 6-32 . 312 WD	
16	5040-0447	2	FOOT REAR	
17	5040-4528	4	GUIDE:PC BOARD GRAY	
18	2950-0001	2	NUT:HEX BRS 3/8 X . 50 AF NI-P	
19	2950-0001	1	NUT:HEX BRS 3/8 X . 50 AF NI-P	
20	2190-0016	2	WASHER:LOCK INT 3/8 PH BRZ	
21	0360-1190	2	TERMINAL:SOLDER LUG . 500 WD	
22	2100-0732	1	R:VARIABLE COMP LIN 500Ω 10% 2W	
23	2950-0038	1	NUT:HEX 5-24 X . 6875	
24	2190-0037	1	WASHER:LOCK INT NO . 1/2. 789 OD STL CAD	
25	2950-0039	1	WASHER:LOCK INT NO . 1/2. 789 PH BRZ	
26	2190-0016	1	WASHER:LOCK INT 3/8 PH BRZ	
27	3101-1234	1	SWITCH:SLIDE DPDT 115/230V	
28	3101-0011	1	SWITCH:SLIDE DPDT 0. 5 AMP 125 VDC	
29	0360-0015	2	BOARD:TERMINAL	
30	2450-0002	2	SCREW:MACH 6-32 X . 25	
31	3050-0066	4	WASHER:FLAT BRASS . 147 ID	

Figure 6-7. Exploded View of Rear Panel (sheet 2 of 2)

Item No.	Part No.	Q'ty	Description	Note
1	04342-1031	1	BRACKET:HANDLE H1	
2	2510-0043	2	SCREW:MACH SST 8-32 X .312	
3	04342-1033	1	BRACKET:HANDLE H3	
4	04342-1034	1	PLATE:HANDLE	
5	2510-0120	2	SCREW:MACH SST 8-32 X .312	
6	04342-3037	1	HANDLE ASS'Y	
7	04342-1034	1	PLATE:HANDLE	
8	2510-0120	2	SCREW:MACH SST 8-32 X .312	
9	04342-1032	1	BRACKET:HANDLE H2	
10	2510-0043	2	SCREW:MACH SST 8-32 X .312	

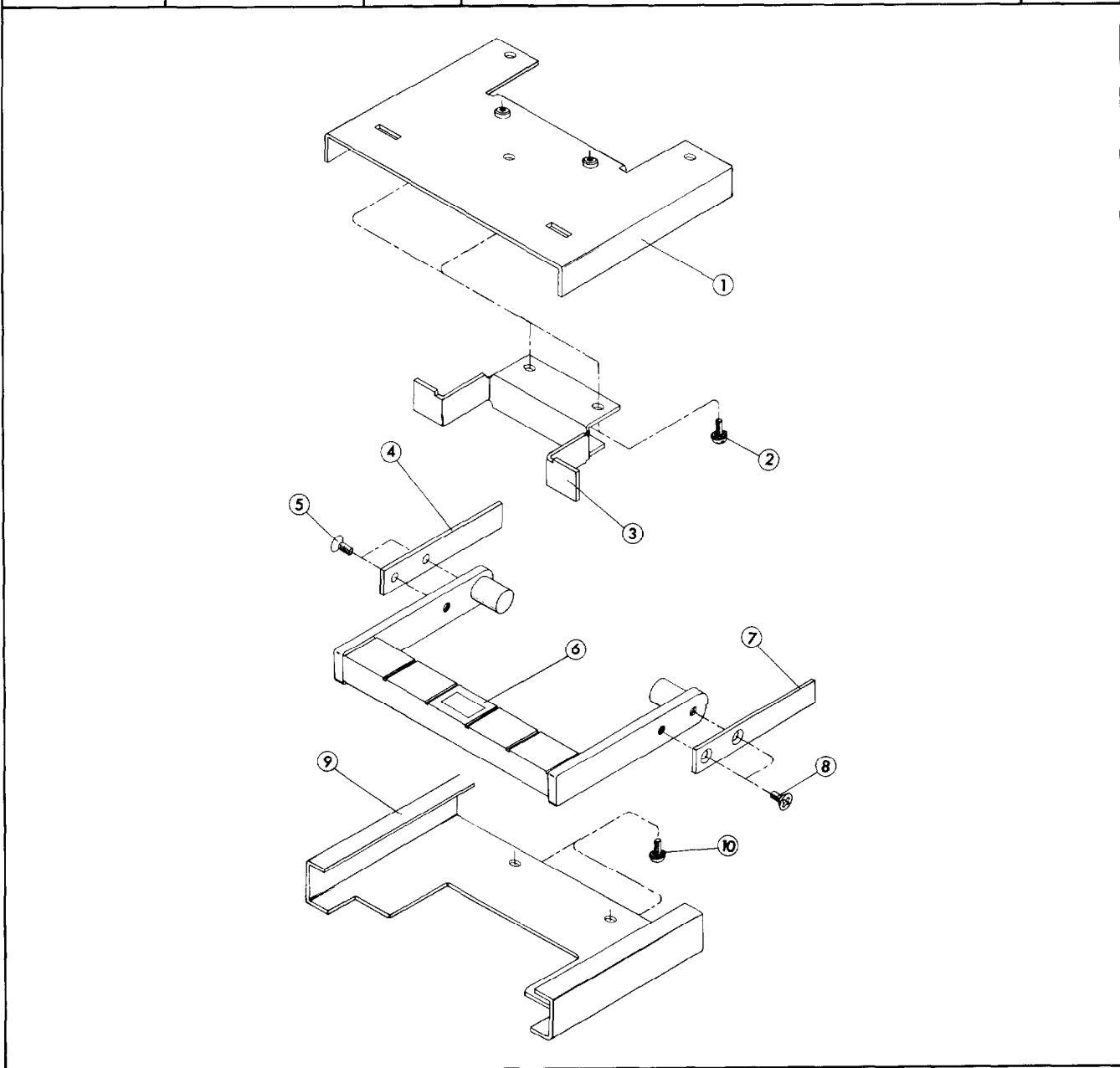

Figure 6-8. Exploded View of Handle Section

SECTION VII MANUAL CHANGES AND OPTIONS

7-1. OPTIONS

7-2. Options are standard modifications performed on HP instruments at the factory. Model 4342A Option 001 low frequency version covering a frequency range from 10kHz to 32MHz is available.

7-3. SPECIAL INSTRUMENTS

7-4. "Specials" are standard HP instruments that are modified according to customer specifications. A separate insert sheet is included with the manual for special instruments having electrical changes. Make the changes specified in addition to any other changes that are necessary.

7-5. MANUAL CHANGES

7-6. This manual applies directly to the Model 4342A with serial prefixed 1212J-00591 and above. The following paragraphs explain how to adapt this manual to apply to later instruments with higher serial prefix, or earlier instruments with lower serial prefix. Technical corrections to this manual (if any) are called errata and are listed on a separate "Manual Changes" sheet supplied with this manual.

7-7. LATER INSTRUMENTS: If the serial prefix of your Model 4342A is above 1212J, refer to a separate "Manual Changes" sheet supplied with this manual. Locate the serial prefix of your instrument and make the indicated changes.

7-8. EARLIER INSTRUMENTS(Backdating Changes): If the serial prefix of your Model 4342A is 1212J-00590 and below, refer to Table 7-1 for the changes necessary to adapt this manual to your particular instrument. Locate the serial prefix of your instrument in the table and make the indicated changes.

Note that instrument - component values that differ from those in this manual, yet are not listed in this backdating changes, should be replaced using the part number given in this manual.

7-9. OPTION 001 INSTRUMENTS: Information about Option 001 is given in Appendix.

Table 7-1. Backdating Changes.

Instrument Serial Prefix or Number	Make Changes
941/942	1, 2, 3, 4, 5, 6, 7, 8, 9, 10, 11
1005/1006J00115 and below	2, 3, 4, 5, 6, 7, 8, 9, 10, 11
1005/1006J00135 and below	3, 4, 5, 6, 7, 8, 9, 10, 11
1018/1019	4, 5, 6, 7, 8, 9, 10, 11
1027/1028	5, 6, 7, 8, 9, 10, 11
1035/1036J00240 and below	6, 7, 8, 9, 10, 11
1035/1036J00290 and below	7, 8, 9, 10, 11
1035/1036J00315 and below	8, 9, 10, 11
1035/1036J00340 and below	9, 10, 11
1211/1212J00570 and below	10, 11
1212J00590 and below	11

CHANGE 1

Page 6-3 and 6-4, Table 6-2, Reference Designation Index
Delete A1A1C31 and A1A1R22.

Page 8-5, Figure 8-3, Oscillator Ass'y A1
Delete A1A1C31 and A1A1R22 from circuit.

Page 6-10, Table 6-2, Reference Designation Index
Delete A5CR1.

Page 8-9, Figure 8-5, Impedance Converter, RF Amplifier & Detector Ass'y A5.
Delete A5CR1 from circuit.

Page 6-14, Table 6-2, Reference Designation Index
Change A7C2 to HP Part No. 0160-0128, C:FXD CER 2.2μF 20% 25VDCW.

Page 8-11, Figure 8-6, Q-Limit Selector Ass'y A7
Change value of A7C2 to 2.2μ.
Change circuit as shown in partial schematic Figure 7-1.

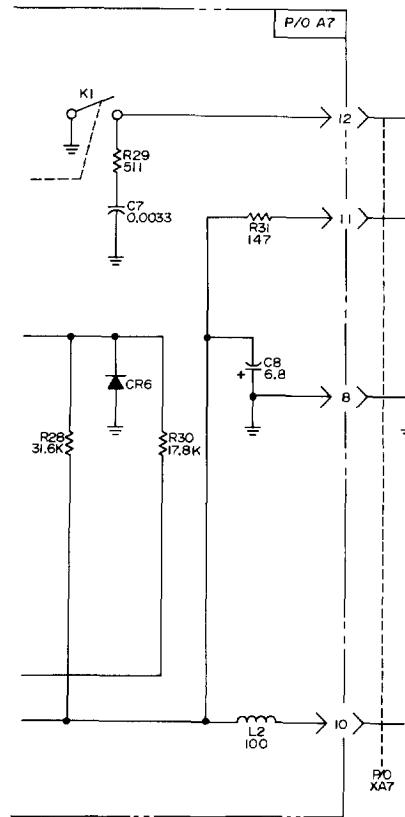

Figure 7-1. A7 04342-7707

Page 6-16, Table 6-2, Reference Designation Index
Change A8CR17 to HP Part No. 1910-0102, SEMICON DEVICE:DIODE GERMANIUM.

Page 6-18, Table 6-2, Reference Designation Index
Delete A8R43.

Page 8-13, Figure 8-7, Power Supply & ALC Amplifier Ass'y A8
Delete A8R43 from circuit.

Page 6-18, Table 6-2, Reference Designation Index
Add A11R1, R2, HP Part No. 0757-0461, R:FXD MET FLM 68.1kΩ 1% 1/8W.

Page 8-7, and 8-9, Figure 8-4 and 8-5, Meter Scale Indicator Ass'y A11
Change circuit as shown in schematic Figure 7-2.

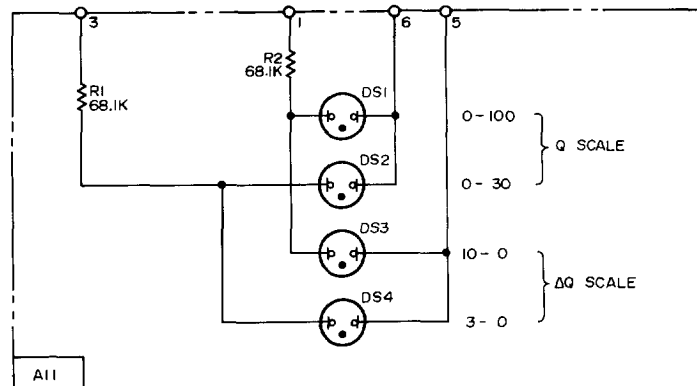

Figure 7-2. A11 04342-7711

CHANGE 2

- Page 6-4, Table 6-2, Reference Designation Index
Change A1A1R8 to HP Part No. 0757-0438, R:FXD MET FLM 5.11k Ω 1% 1/8W.
Change A1A1R20 to HP Part No. 0757-0346, R:FXD MET FLM 10 Ω 1% 1/8W, and
remove asterisk (*) from A1A1R20.
Delete A1A1R23.
- Page 8-5, Figure 8-3, Oscillator Ass'y A1
Change value of A1A1R8 to 5110 Ω .
Change value of A1A1R20 to 10 Ω , and remove asterisk (*) from A1A1R20.
Delete A1A1R23 from circuit.

CHANGE 3

- Page 6-4, Table 6-2, Reference Designation Index
Delete A1A1L9.
- Page 8-5, Figure 8-3, Oscillator Ass'y A1
Delete A1A1L9 from circuit.
- Page 6-7, Table 6-2, Reference Designation Index, Miscellaneous
Change HP Part No. of PLATE: TERMINAL to 04342-3221.
- Page 6-11, Table 6-2, Reference Designation Index
Change A5C23 to HP Part No. 0180-0376, C:FXD TA 0.47 μ F 10% 35VDCW.
Delete A5R44 and R45.
Add A5L1 and L3 HP Part No. 9140-0179, COIL:FXD RF 22 μ H 10%.
- Page 8-9, Figure 8-5, Impedance Converter, RF Amplifier & Detector Ass'y A5
Change value of A5C23 to 0.47 μ F.
Replace A5R44 and R45 with A5L1 and L3, 22 μ H respectively.

CHANGE 4

- Page 6-3, Table 6-2, Reference Designation Index
Change HP Part No. of A1A1 to 04342-7701.
Change HP Part No. of A1A1 BLANK PC BOARD to 04342-8701.
- Page 8-3, Figure 8-2, Functional Overall Block Diagram
Change HP Part No. of A1A1 Oscillator Board to 04342-7701.
- Page 8-5, Figure 8-3, Oscillator Ass'y A1
Change HP Part No. of A1A1 Oscillator Board Ass'y to 04342-7701
- Page 6-4, Table 6-2, Reference Designation Index, Miscellaneous
Change HP Part No. of PLATE:ANGLE to 04342-1074
- Page 6-8, Table 6-2, Reference Designation Index, Miscellaneous
Delete ANGLE: SHIELD HP Part No. 04342-1048.
Add SHIELD HP Part No. 04342-1055 and ANGLE (2 REQ'D) HP Part No. 04342-1056.
- Page 6-12, Table 6-2, Reference Designation Index
Change A6CR2 and CR3 to HP Part No. 1902-0041, SEMICON DEVICE:DIODE
BREAKDOWN 5.11V 5% 400mW.
- Page 8-9, Figure 8-5, DC Amplifier Ass'y A6
Change values of A5CR2 and CR3 to 5.11V

Page 6-13, Table 6-2, Reference Designation Index
Change A6R26 to HP Part No. 0698-4433, R:FXD MET FLM 2.26k Ω 1% 1/8W.
Change A6R29 to HP Part No. 0757-0433, R:FXD MET FLM 3.32k Ω 1% 1/8W.

Page 8-9, Figure 8-5, DC Amplifier Ass'y A6
Change value of A6R26 to 2260 Ω .
Change value of A6R29 to 3320 Ω .

Page 6-20, Table 6-2, Reference Designation Index
Change HP Part No. of XA6 and XA7 to 1251-0160.
Change HP Part No. of FRONT PANEL ASS'Y to 04342-1021.
Change HP Part No. of BOTTOM COVER to 04342-1029.

CHANGE 5

Page 6-14, Table 6-2, Reference Designation Index
Change A7CR1 to HP Part No. 1902-0041, SEMICON DEVICE:DIODE BREAKDOWN
5.11V 5% 400mW.
Change A7R7 to HP Part No. 2100-1759, R:VAR WW 2k Ω 5% 1W.

Page 8-11, Figure 8-6, Q-Limit Selector Ass'y A7
Change value of A7CR1 to 5.11V.
Change value of A7R7 to 2000 Ω .

CHANGE 6

Page 6-4, Table 6-2, Reference Designation Index
Delete A1A1L10.

Page 8-5, Figure 8-3, Oscillator Ass'y A1
Delete A1A1L10 from circuit.

CHANGE 7

Page 6-9, Table 6-2, Reference Designation Index
Change A4C3 to HP Part No. 0180-0374, C:FXD TA 10 μ F 10% 20VDCW.

Page 8-7, Figure 8-4, Impedance Converter Ass'y A4
Change value of A4C3 to 10 μ F.

Page 6-19, Table 6-2, Reference Designation Index
Change C1a and C1b to HP Part No. 0150-0119, C:FXD CER 2 x 0.01 μ F 20% 250WVAC.

Page 8-13, Figure 8-7, Power Supply & ALC Amplifier Ass'y A8
Change circuit as shown in partial schematic Figure 7-3.

CHANGE 8

Page 6-14, Table 6-2, Reference Designation Index
Change A7R7 to HP Part No. 2100-1910, R:VAR MET FLM 100k Ω 2% 3/4W.

Page 8-11, Figure 8-6, Q Limit Selector Ass'y A7
Change value of A7R7 to 100k Ω .

CHANGE 9

Page 6-10, Table 6-2, Reference Designation Index
Change A5C7 to HP Part No. 0180-1745, C:FXD TA 1.5 μ F 10% 20VDCW.
Change A5C13 to HP Part No. 0160-2201, C:FXD MICA 51pF 5% 300VDCW.
Change A5C15* to HP Part No. 0160-2266, C:FXD CER 24pF 5% 500VDCW.

Page 6-11, Table 6-2, Reference Designation Index

Change A5R33 to HP Part No. 0698-3433, R:FXD MET FLM 28.7Ω 1% 1/8W.
 Change A5R42 to HP Part No. 0757-0442, R:FXD MET FLM 10kΩ 1% 1/8W.

Page 8-9, Figure 8-5, Impedance Converter, RF Amplifier & Detector Ass'y A5

Change value of A5C7 to 1.5μF.
 Change value of A5C13 to 51pF.
 Change value of A5C15* to 24pF.
 Change value of A5R33 to 28.7Ω
 Change value of A5R42 to 10kΩ.

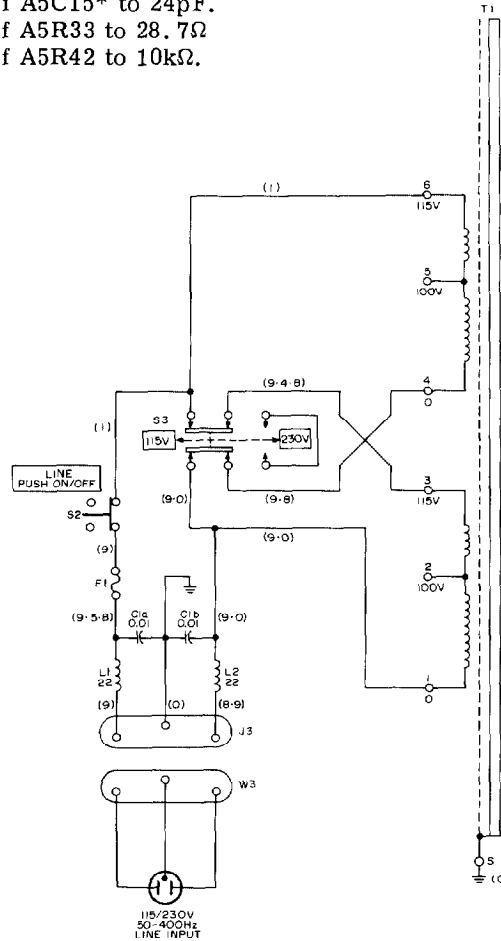

Figure 7-3. Partial Schematic of Power Supply

CHANGE 10

Page 6-3, Table 6-2, Reference Designation Index

Change HP Part No. of A1A1 to 04342-7731.
 Change HP Part No. of Board Blank PC for A1A1 to 04342-8731.

Page A-3, Table A-1, Reference Designation Index

Change HP Part No. of A1A1 to 04342-7741.
 Change HP Part No. of Board Blank PC for A1A1 to 04342-8741.

Page 8-5, Figure 8-3, A1, A3, A8 and A10 Ass'y

Change HP Part No. of A1A1 to 04342-7731.

Page A-7, Figure A-1, A1 (opt 001) and A10 Ass'y

Change HP Part No. of A1A1 to 04342-7741.

CHANGE 11

Page 6-20, 6-21, Table 6-2, Reference Designation Index

Change HP Part No. of PANEL ASS'Y FRONT to 04342-1049.

Change HP Part No. of COVER ASS'Y TOP to 04342-1028.

Change HP Part No. of COVER BOTTOM to 04342-1027.

Change HP Part No. of BRACKET HANDLE H1 to 04342-1031.

Change HP Part No. of BRACKET HANDLE H2 to 04342-1032.

Page 6-22, Figure 6-1, Exploded View of OSC Ass'y (sheet 1 of 2).

Change partial illustrated parts identification of Figure 6-1 as shown below:

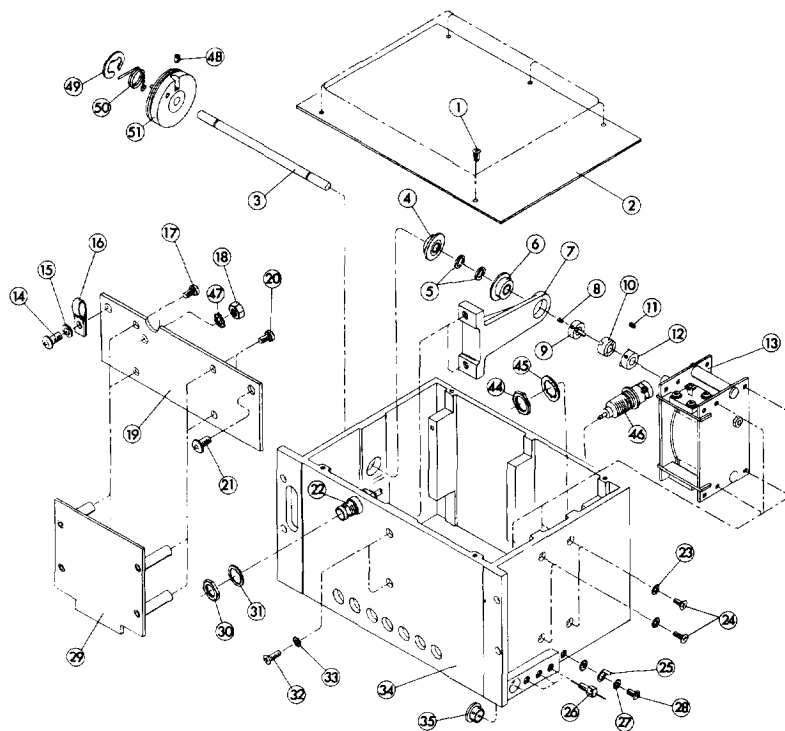

Page 6-23, Figure 6-1, Exploded View of OSC Ass'y (sheet 2 of 2)
 Change Parts List of Figure 6-1 as follows:

Item No.	Part No.	Q'ty	Description	Note
1	2360-0115	5	SCREW:MACH SST 6-32 X . 312	
2	04342-1070	1	COVER:TOP	
3	04342-3092	1	SHAFT:OSCILLATOR	
4	1410-0307	1	BEARING	
5	0510-0045	2	RING:RET EXT . 188 DIA	
6	1410-0307	1	BEARING	
7	04342-3093	1	BRACKET:SHAFT	
8	3030-0033	2	SCREW:SET 6-32 X . 188 LG HEX SKT . DR	
9	1500-0005	1	HUB:COUPLER (BRASS)	
10	1500-0004	1	HUB:COUPLER (NYLON)	
11	3030-0033	2	SCREW:SET 6-32 X . 188 LG HEX SKT . DR	
12	04342-3096	1	HUB:COUPLER (BRASS)	
13	0121-0232	1	CAPACITOR:AIR	
14	2360-0199	1	SCREW:MACH SST 6-32 X . 438 PH	
15	3050-0066	1	WASHER:BRASS . 147 ID	
16	1400-0325	1	CLAMP:CABLE (NYLON)	
17	2360-0115	2	SCREW:MACH SST 6-32 X . 312	
18	2740-0003	1	NUT:HEX 10-32 X . 375	
19	04342-1073	1	PLATE	
20	2360-0115	2	SCREW:MACH SST 6-32 X . 312	
21	2360-0119	2	SCREW:MACH SST 6-32 X . 438 PH	
22	04342-7601	1	CABLE ASS'Y	
23	2190-0047	4	WASHER:LOCK CNTRSK NO. 6	
24	0570-0237	4	SCREW:MACH BRASS 3mm	
25	0360-0032	1	TERMINAL:LUG	
26	0160-2357	3	C:FXD CER 1000pF	
27	2190-0008	1	WASHER:LOCK EXT PHS . BRZ . 141 ID	
28	2360-0115	1	SCREW:MACH SST 6-32 X . 312	
29	04342-7702	1	PC BOARD:A1A2 ASS'Y	
30	2190-0102	1	WASHER:LOCK BRZ . 475 ID	
31	2950-0035	1	NUT HEX BRASS 15/32-32	
32	2360-0200	2	SCREW:MACH SST 6-32 X . 500	
33	2190-0047	2	WASHER:LOCK CNTRSK NO. 6	
34	04342-5001	1	CASE:OSCILLATOR (CASTING)	
35	0400-0111	1	GROMMET:SNAP IN	
36	2360-0115	1	SCREW:MACH SST 6-32 X . 312	
37	04342-7731/41	1	PC BOARD:A1A1 ASSEMBLY	
38	2360-0115	1	SCREW:MACH SST 6-32 X . 312	
39	2360-0115	3	SCREW:MACH SST 6-32 X . 312	
40	2360-0115	1	SCREW:MACH SST 6-32 X . 312	
41	04342-1071	1	COVER BOTTOM	
42	2360-0115	1	SCREW:MACH SST 6-32 X . 312	
43	2360-0115	3	SCREW:MACH SST 6-32 X . 312	
44	2950-0035	1	NUT:HEX BRASS 15/32-32	
45	2190-0102	1	WASHER:LOCK BRZ . 475 ID	
46	1250-0314	1	CONNECTOR:BNC FEMALE	
47	2190-0012	1	WASHER:LOCK EXT BRZ	
48	3030-0033	1	SCREW:SET 6-32 X . 188LG HEX SKT . DR	
49	0510-0080	1	RING:RET EXT . 500 DIA E TYPE	
50	04342-8524	1	SPRING:COIL	
51	04342-5035	1	PULLEY:MOLDED	

Figure 6-1. Exploded View of Oscillator Ass'y (sheet 2 of 2)

SECTION VIII

CIRCUIT DIAGRAMS

8-1. INTRODUCTION

8-2. This section includes the following:

- a. General Notes for schematic diagrams.
- b. Functional Overall Block Diagram (Figure 8-2).
- c. Schematic Diagrams and Parts Location Illustrations. Waveforms and voltages at indicated test points are also included.

8-3. Circuit diagrams of Option 001 are given in APPENDIX. A1 and A5 Ass'y circuit diagrams are different from the Standard Model 4342A. For other assemblies, refer to this section.

8-4. GENERAL NOTES

- a. Unless otherwise indicated, resistance in ohms, capacitance in microfarads and inductance in microhenries.

b. Components assigned an asterisk (*) are factory selected, average values shown.

c. (9.4.7) indicates wire color code. Wire color code (MIL-STD-681) same as resistor color code. First number identifies ground color, second number identifies wide stripe, third number identifies narrow stripe, i. e. (9.4.7) denotes white ground, yellow wide stripe, violet narrow stripe.

d. The components mounted on chassis or main-frame parts are not assigned an assembly designation (i. e. R1, Q1, etc.).

e. Reference designations (R1, Q1, etc.) within assembly (A1, A2, . . . etc.) use assembly designation as prefix to form complete designation. (i. e. R1 in A1 assembly is A1R1)

8-5. Additional notes are shown in Figure 8-1.

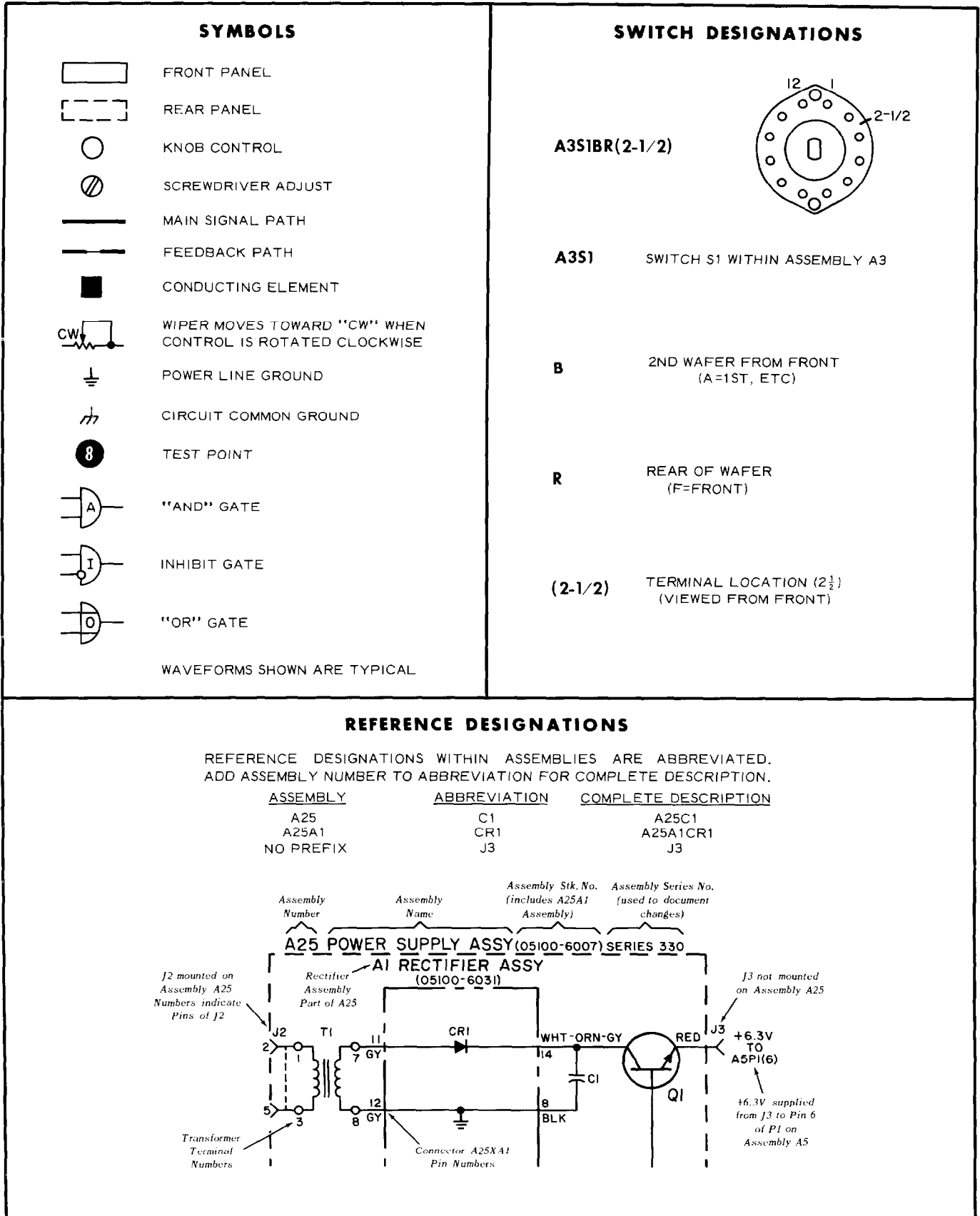
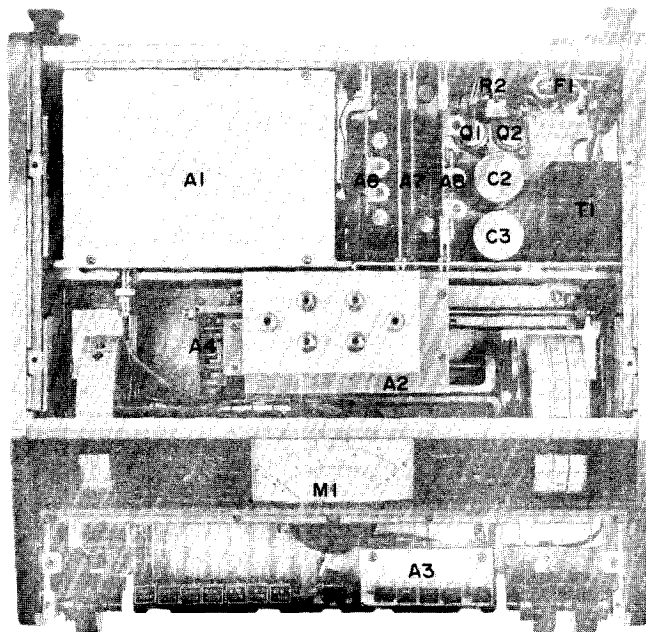
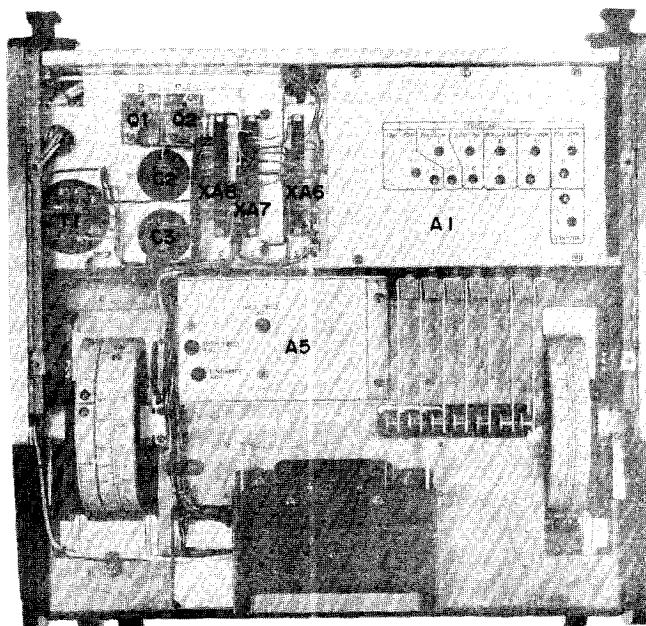

Figure 8-1. Schematic Diagram Notes



TOP VIEW



BOTTOM VIEW

ASSEMBLY LOCATION

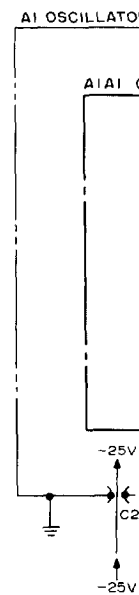

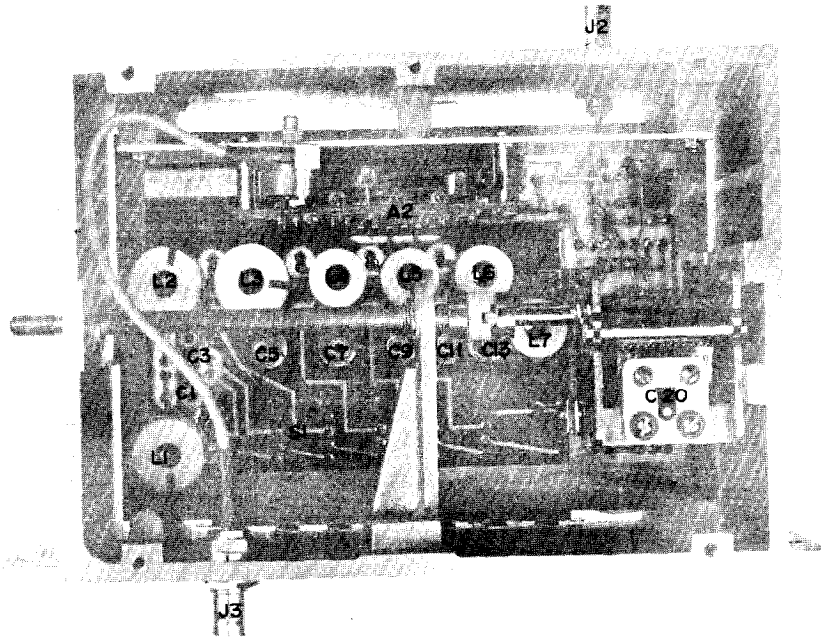

OSCILLATOR ASS'Y A1 (TOP VIEW)
COMPONENT LOCATION

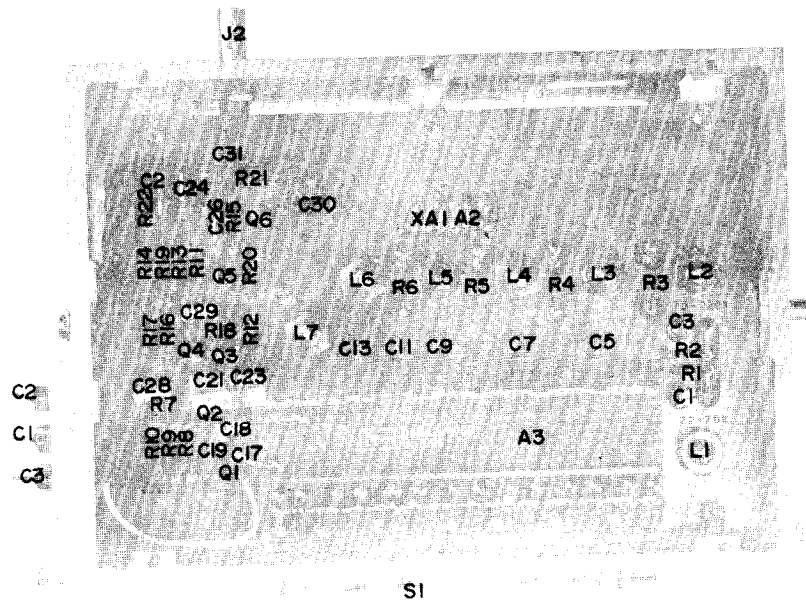

OSCILLATOR ASS'Y A1 (BOTTOM VIEW)
COMPONENT LOCATION

(04342-7020)

OSCILLATOR BOARD (04342-7731; FOR OPTION 001, 04342-7741)

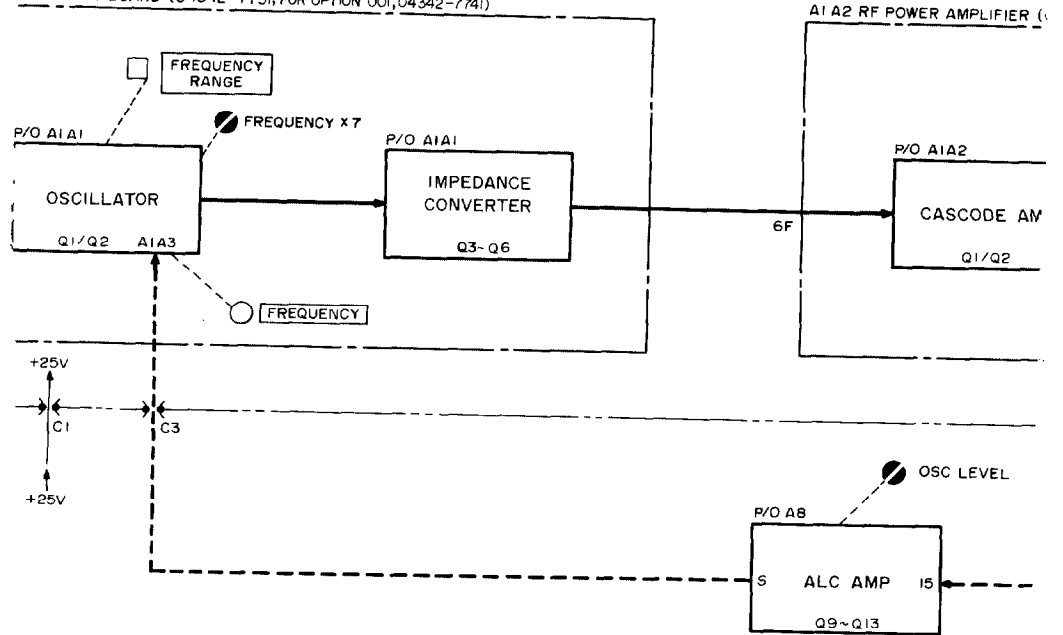

LIMIT SELECTOR (04342-7707)

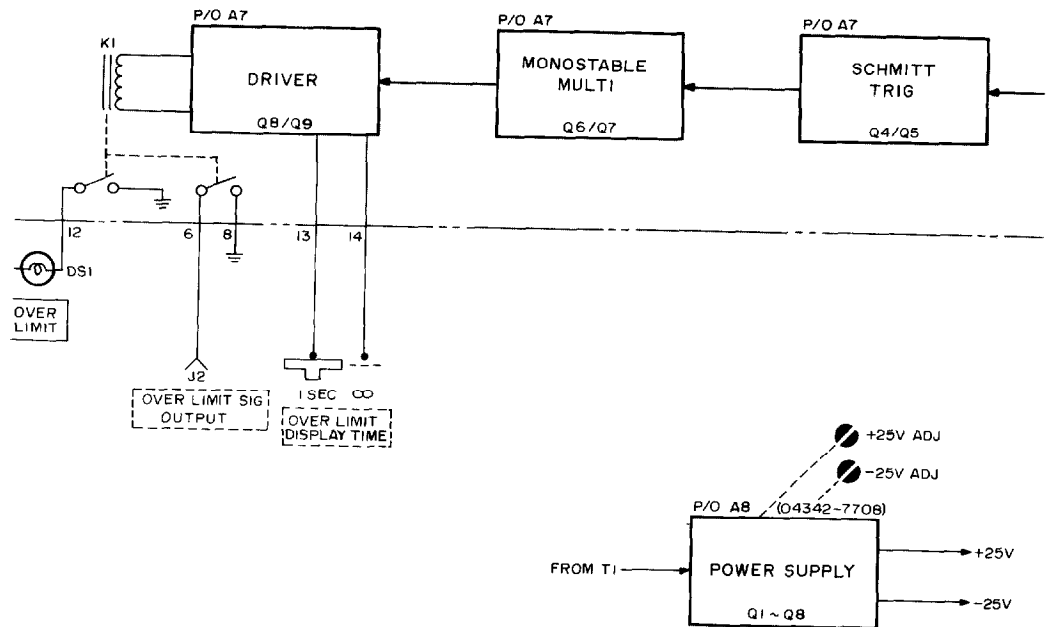

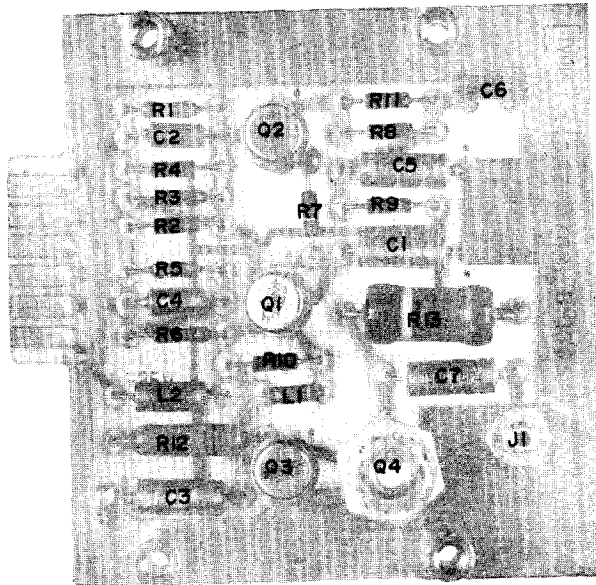

RF POWER AMPLIFIER ASS'Y AIA2
COMPONENT LOCATION

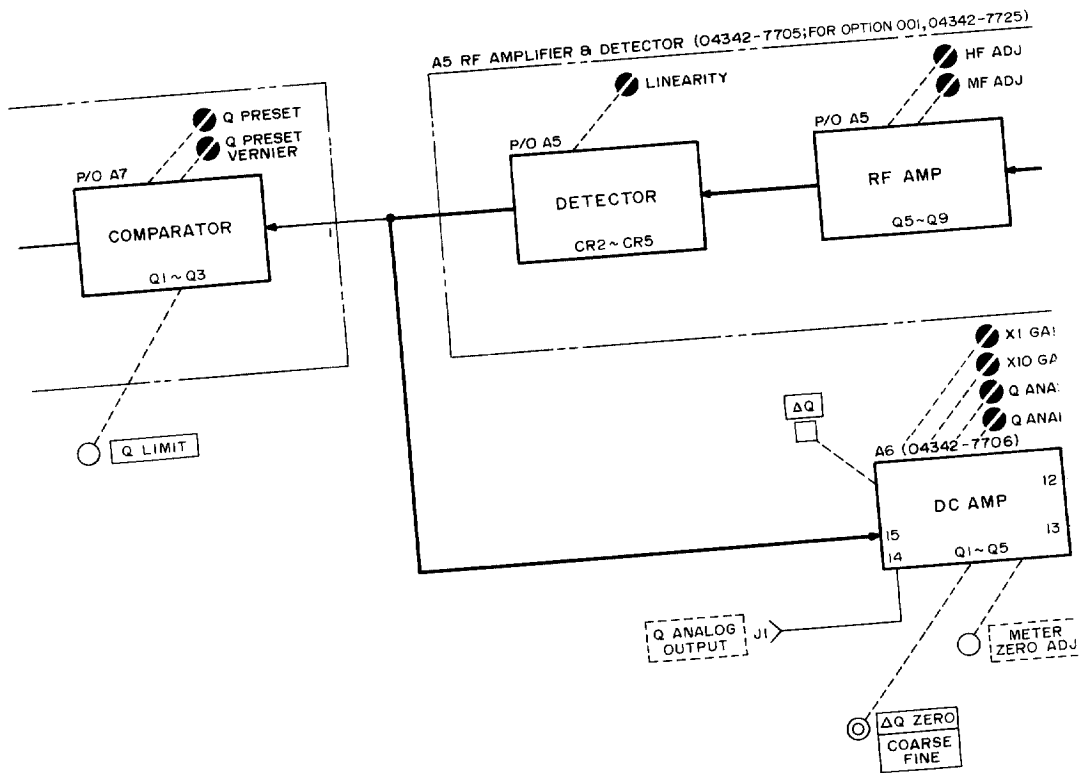
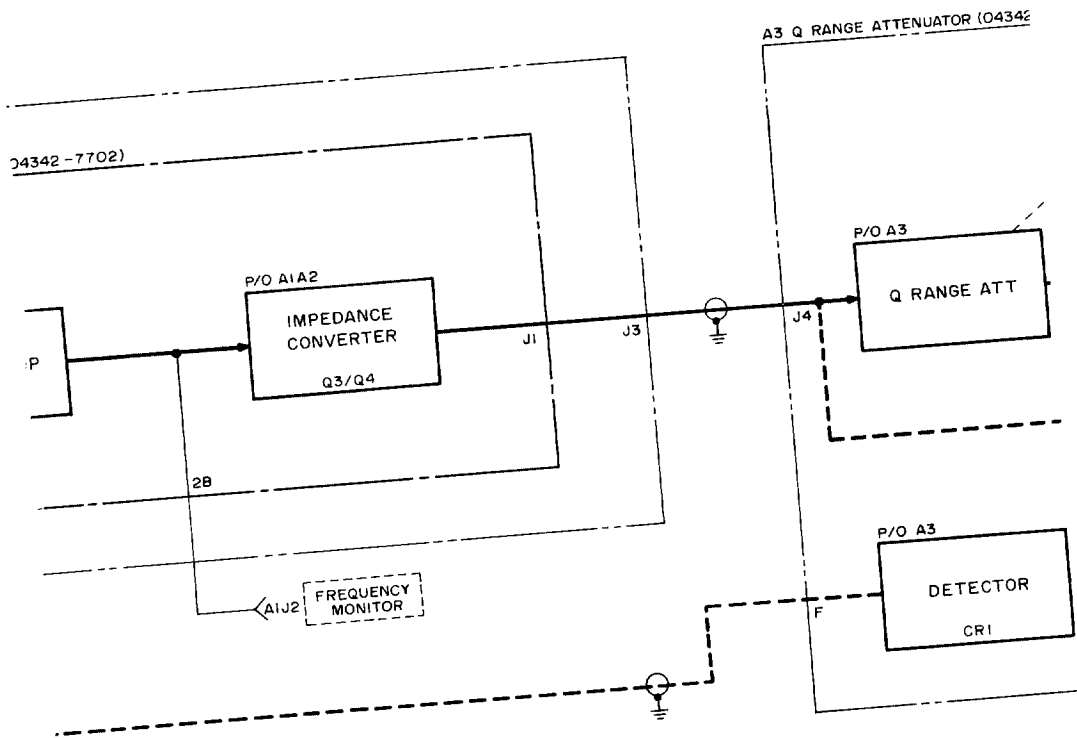

 SEE INSIDE

Figure 8-2
FUNCTIONAL OVERALL BLOCK DIAGRAM

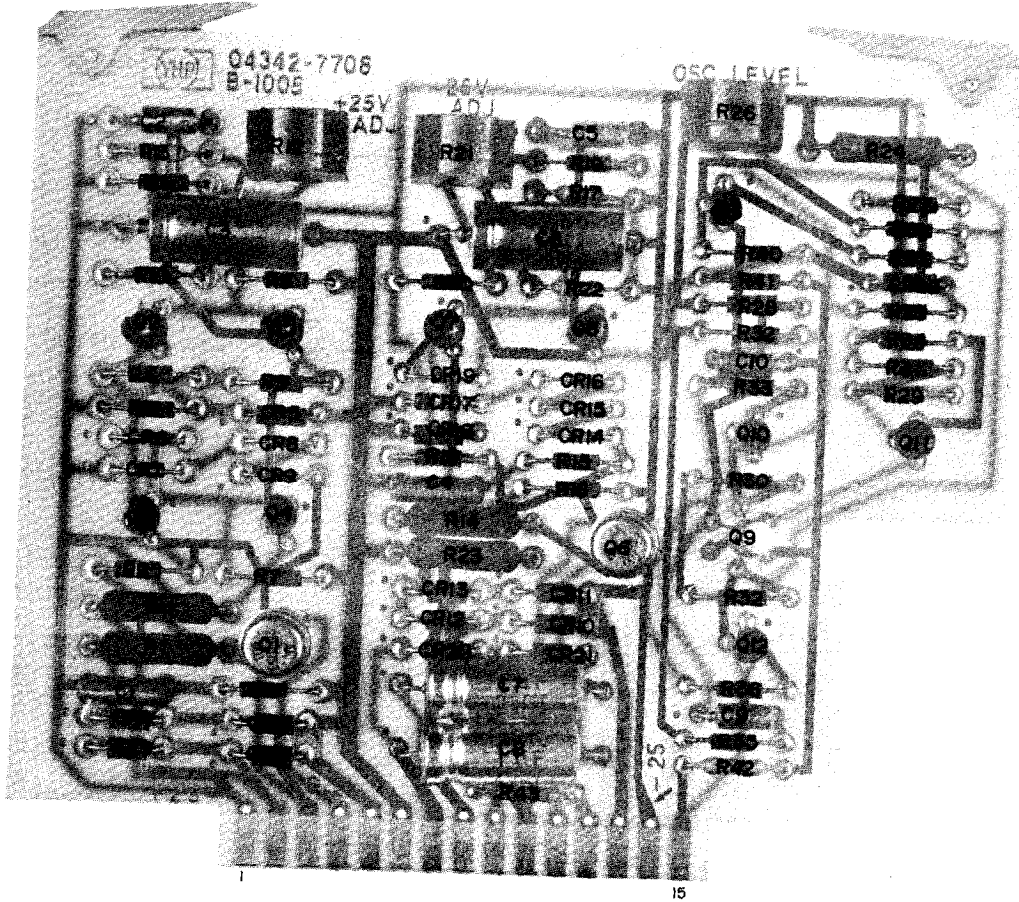

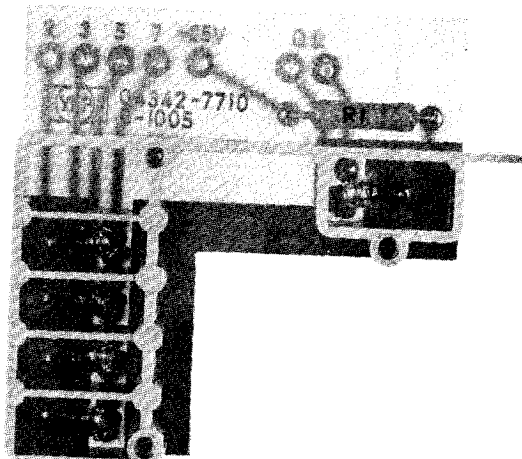

POWER SUPPLY & ALC AMPLIFIER ASS'Y A8
COMPONENT LOCATION



FREQUENCY MULTIPLIER & OVER LIMIT INDICATOR ASS'Y A10
COMPONENT LOCATION

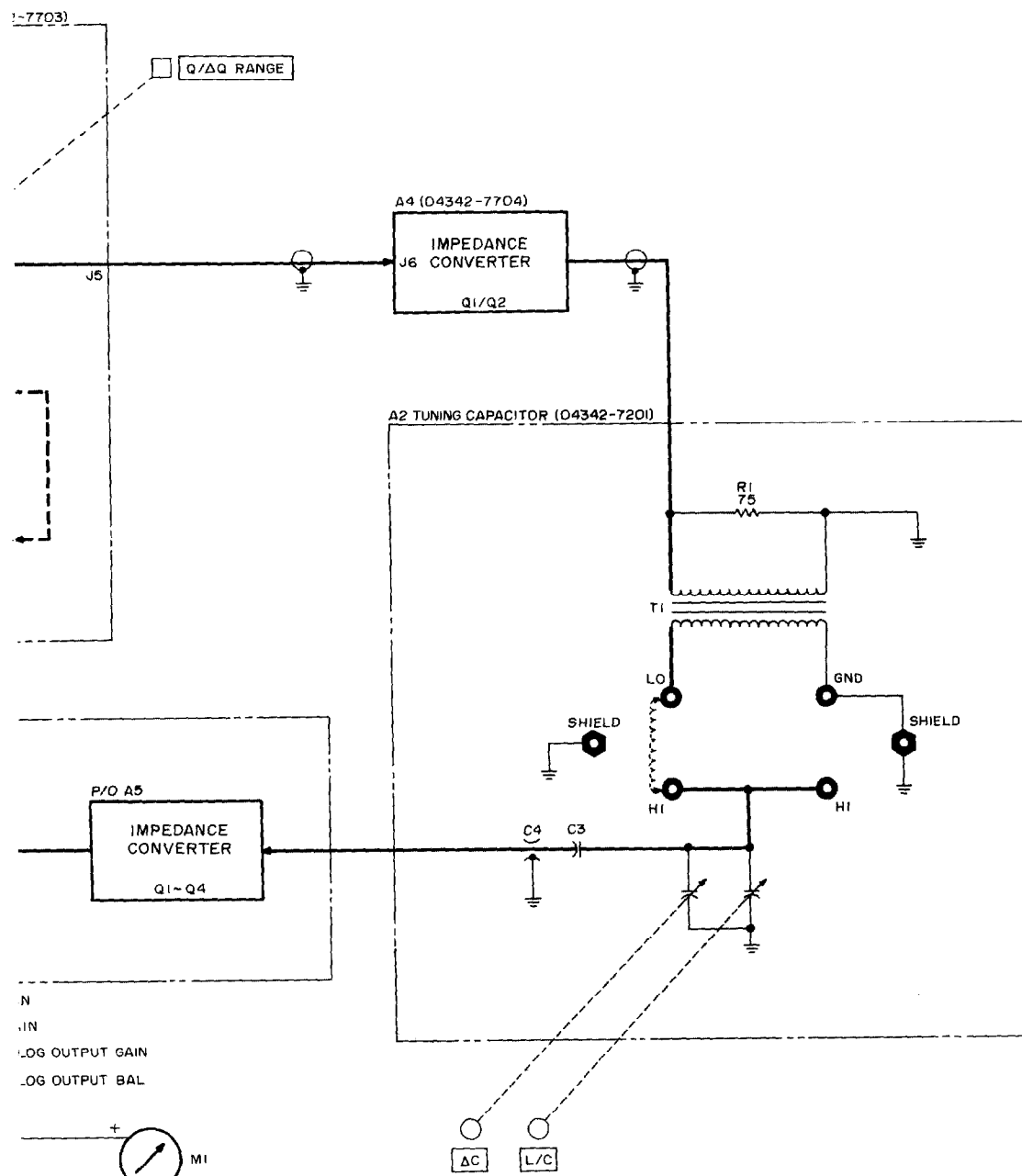

COPYRIGHT 1970 BY YOKOGAWA-HEWLETT-PACKARD, LTD.

Figure 8-2. Functional Overall Block Diagram

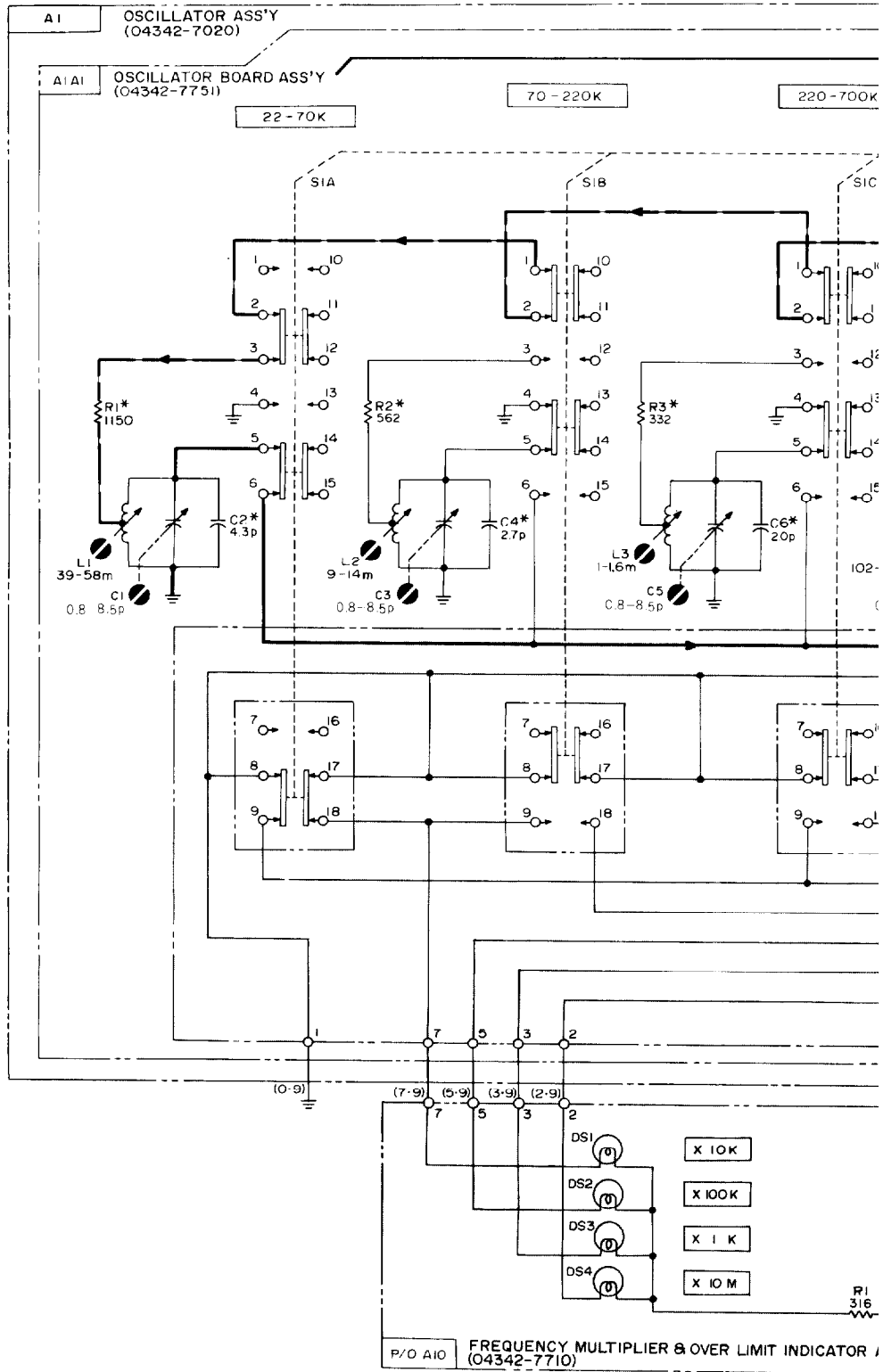

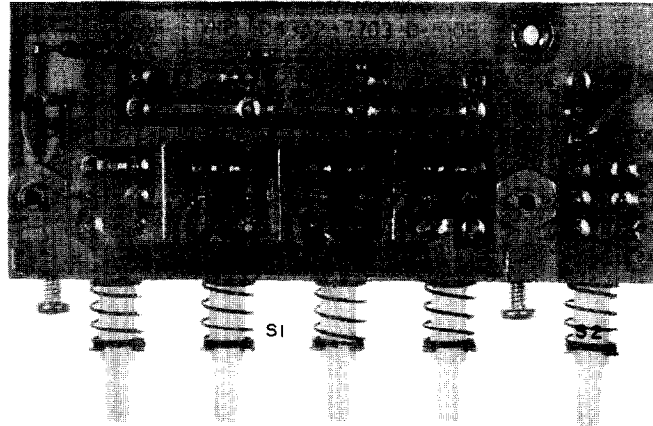

**Q RANGE ATTENUATOR ASS'Y A3
COMPONENT LOCATION**

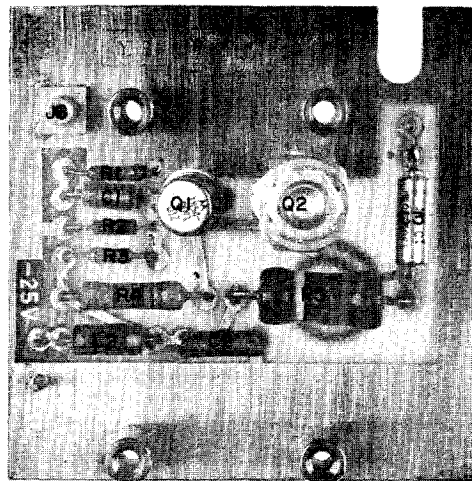

**IMPEDANCE CONVERTER ASS'Y A4
COMPONENT LOCATION**

L - C OSCILLATOR

.7 - 2.2 M

2.2 - 7 M

7 - 22 M

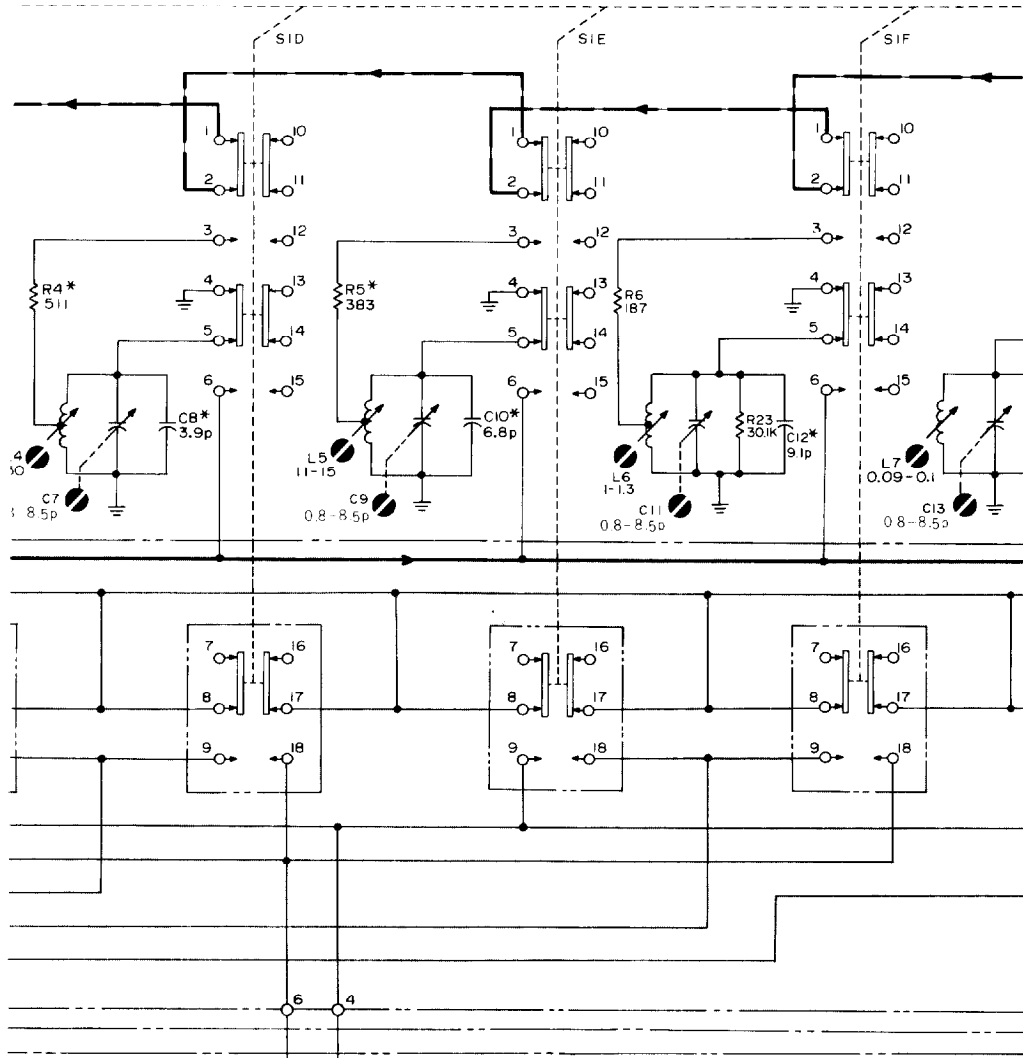

FREQUENCY SCALE INDICATOR

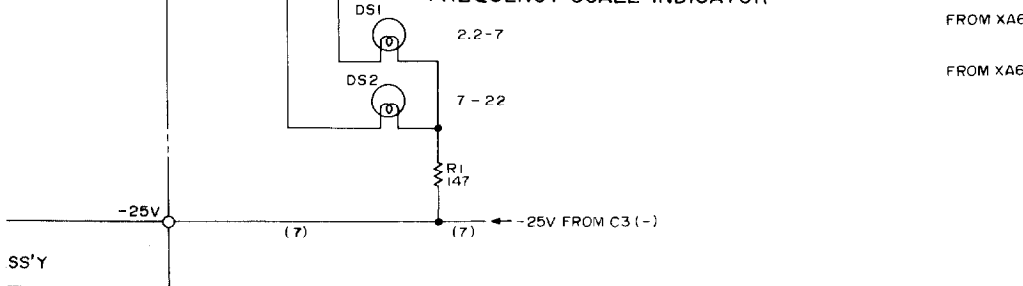

FROM XA6

FROM XA6

SS'Y



SEE INSIDE

Figure 8-3

OSCILLATOR ASS'Y A1
Q RANGE ATTENUATOR ASS'Y A3
POWER SUPPLY & ALC AMPLIFIER ASS'Y A8
FREQUENCY MULTIPLIER & OVER LIMIT INDICATOR ASS'Y A10

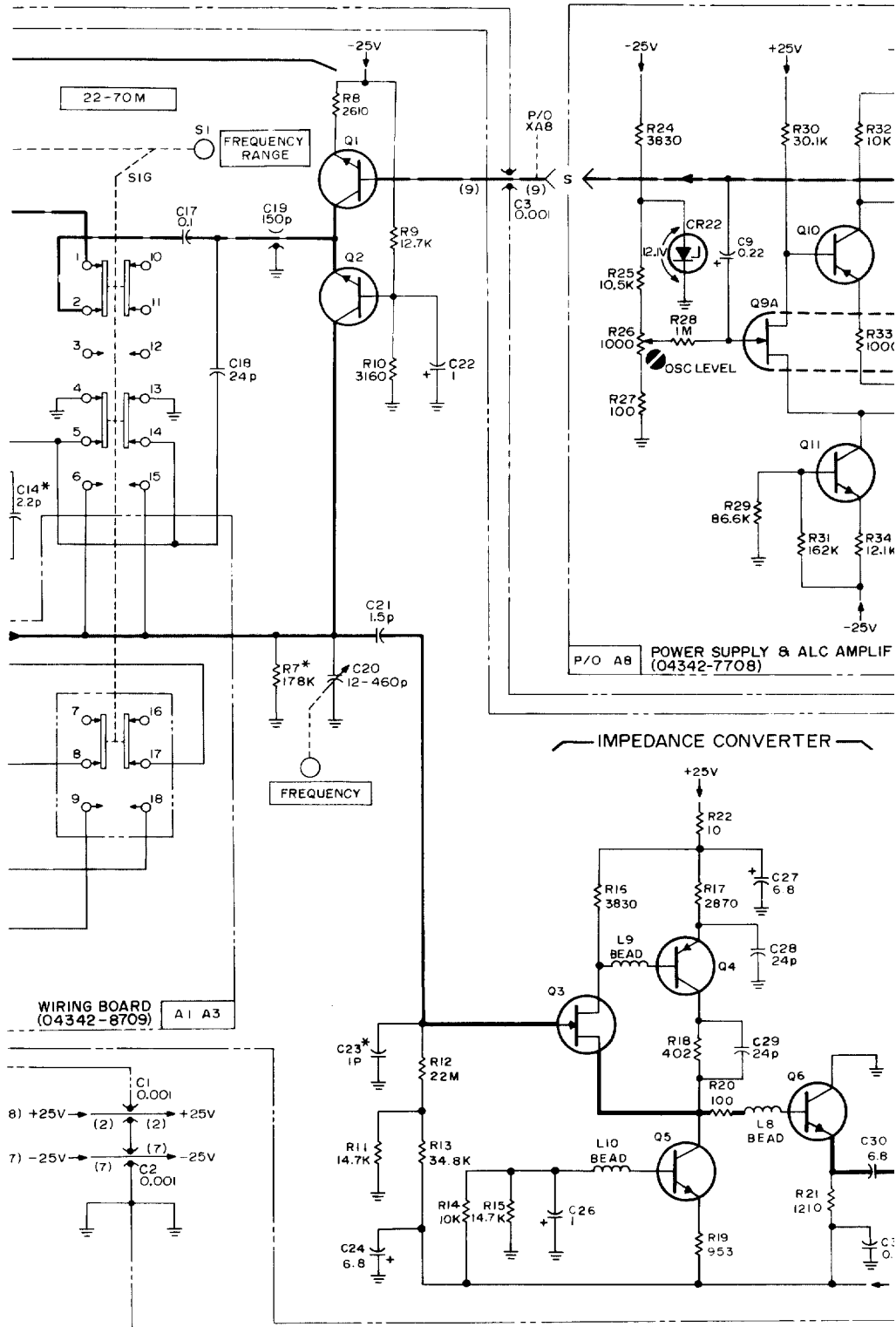

Section VIII
Figure 8-3

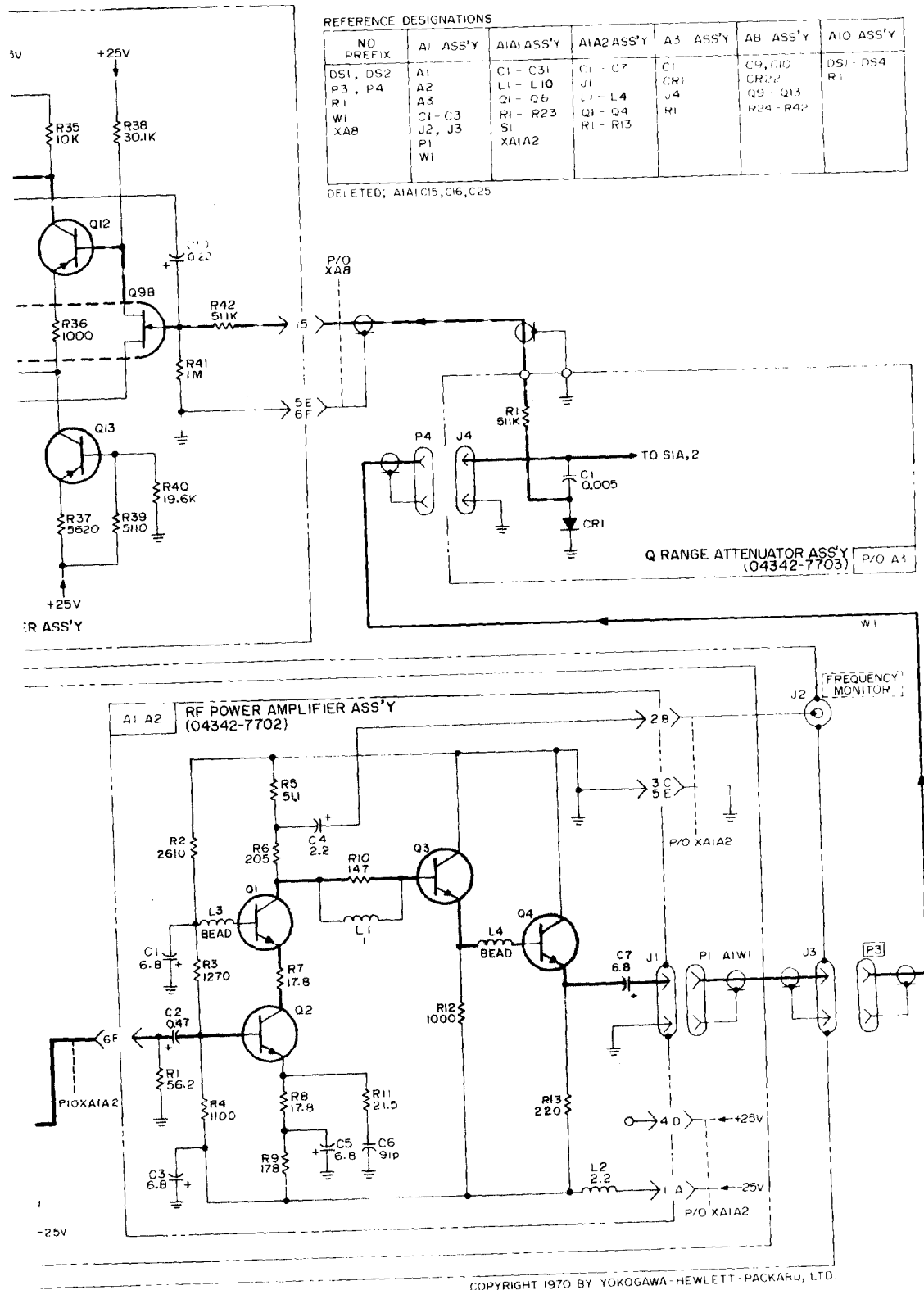
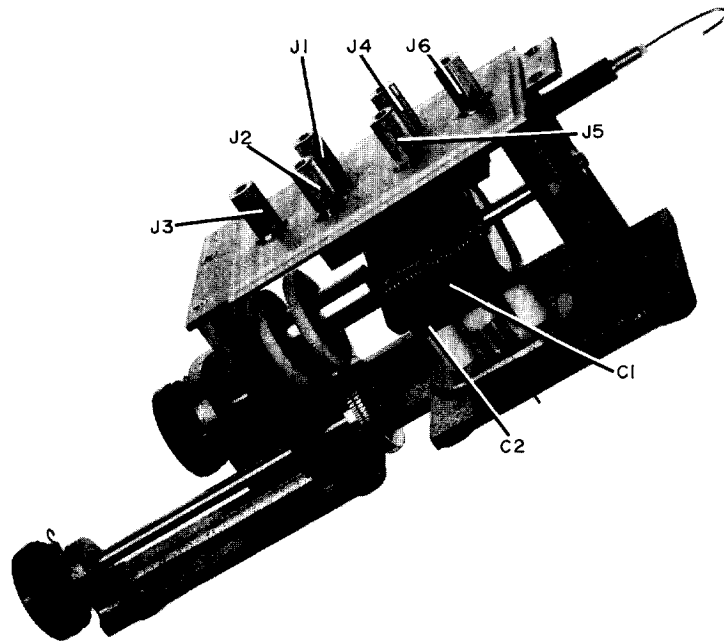
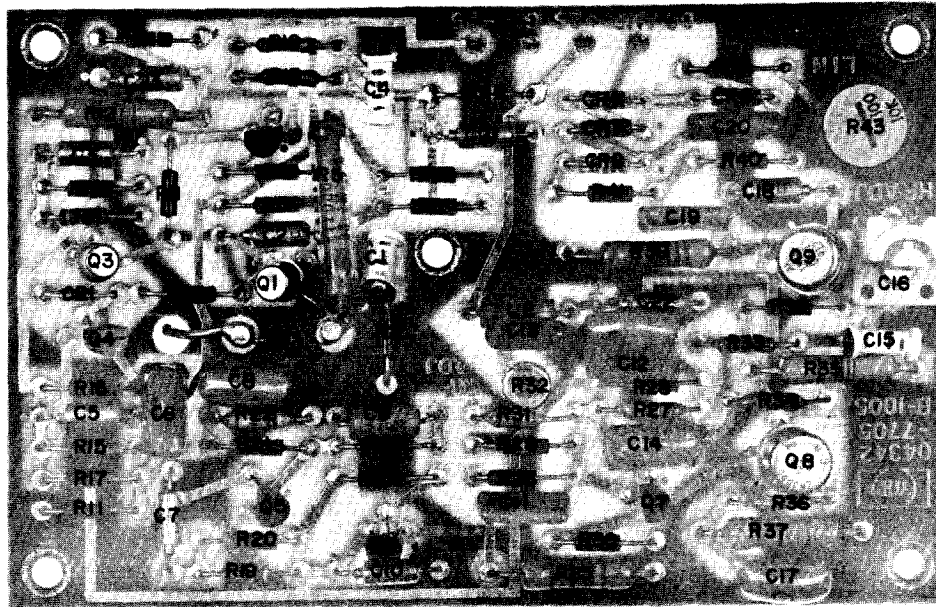

Figure 8-3. Oscillator Ass'y A1
Q Range Attenuator Ass'y A3
Power Supply & ALC Amplifier Ass'y A8
Frequency Multiplier & Over Limit Indicator Ass'y A10

Model 4342A



**TUNING CAPACITOR ASS'Y A2
COMPONENT LOCATION**



**IMPEDANCE CONVERTER , RF AMPLIFIER & DETECTOR ASS'Y A5
COMPONENT LOCATION**

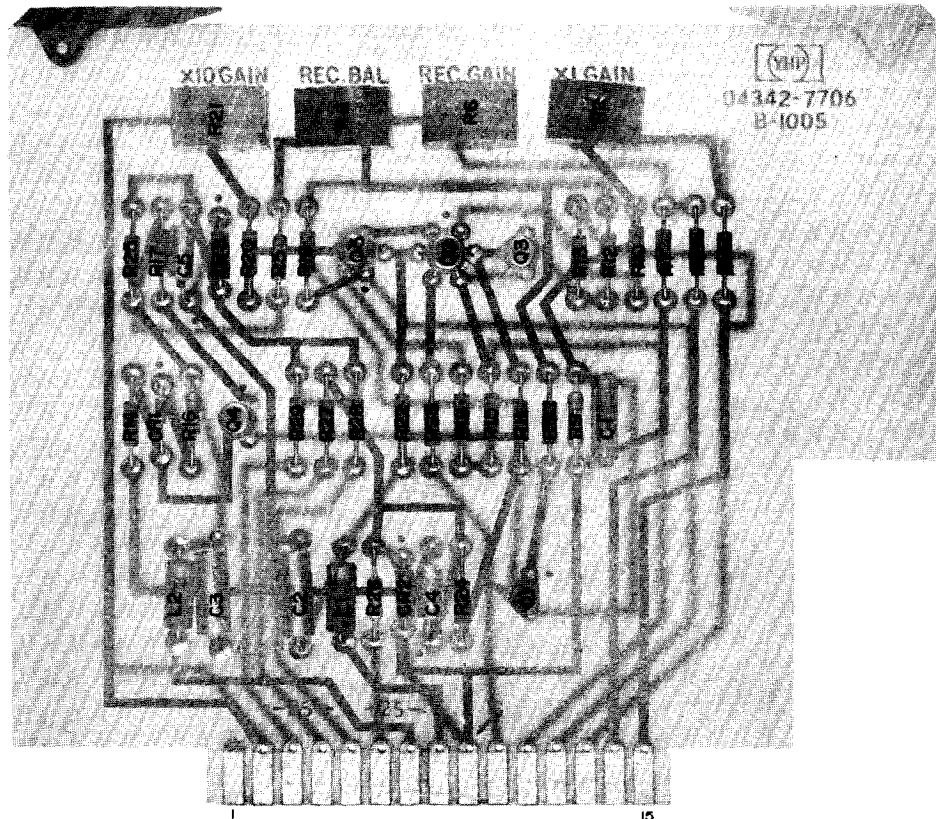

**DC AMPLIFIER ASS'Y A6
COMPONENT LOCATION**

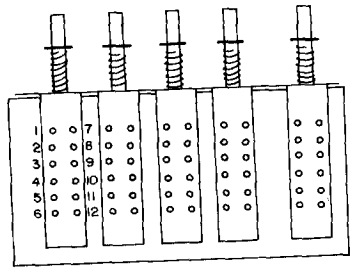
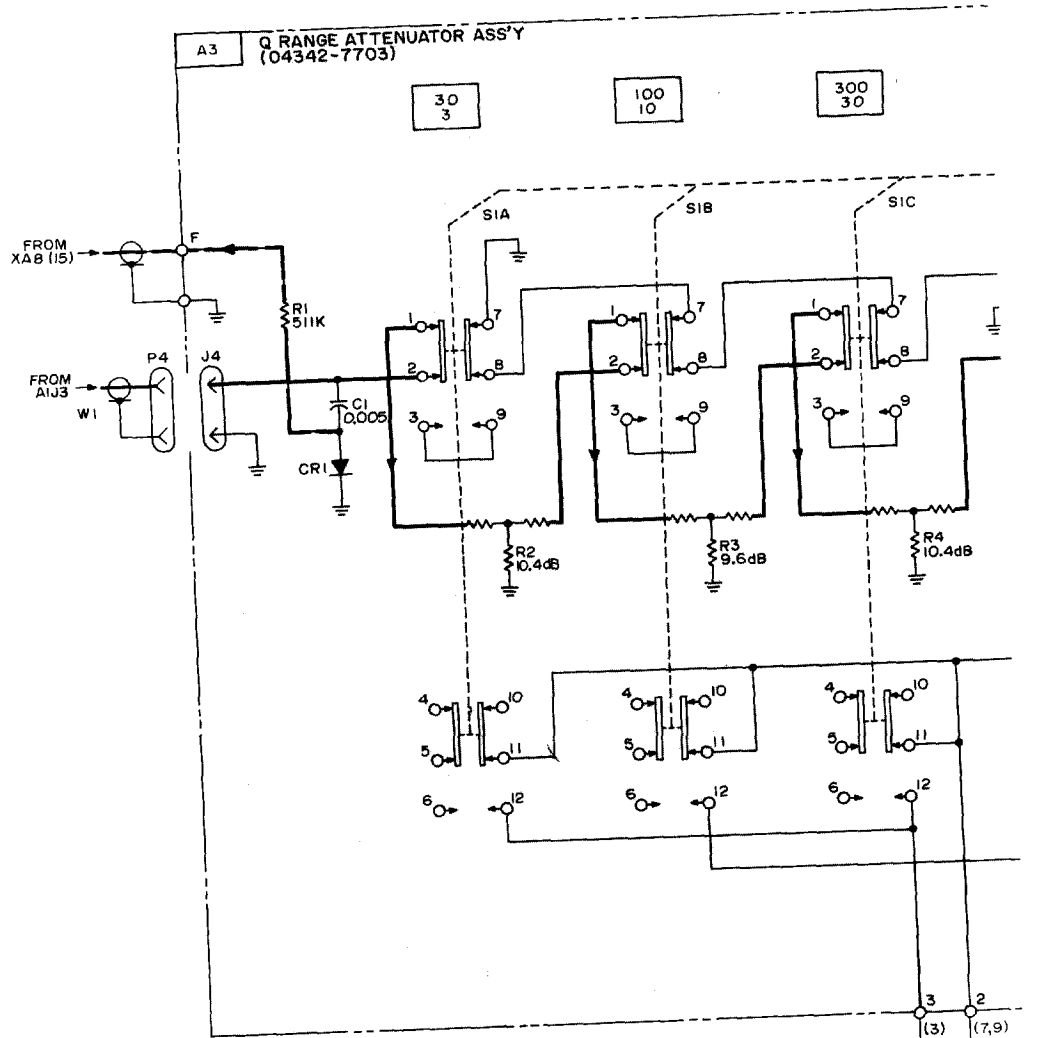

BOTTOM-SIDE VIEW OF
Q RANGE ATTENUATOR ASS'Y
(04342-7703)

FROM XAB (12N) -70V

A11 METER SC
(04342-7703)



SEE INSIDE

Figure 8-4

TUNING CAPACITOR ASS'Y A2
Q RANGE ATTENUATOR ASS'Y A3
IMPEDANCE CONVERTER ASS'Y A4
MATER SCALE INDICATOR ASS'Y A11

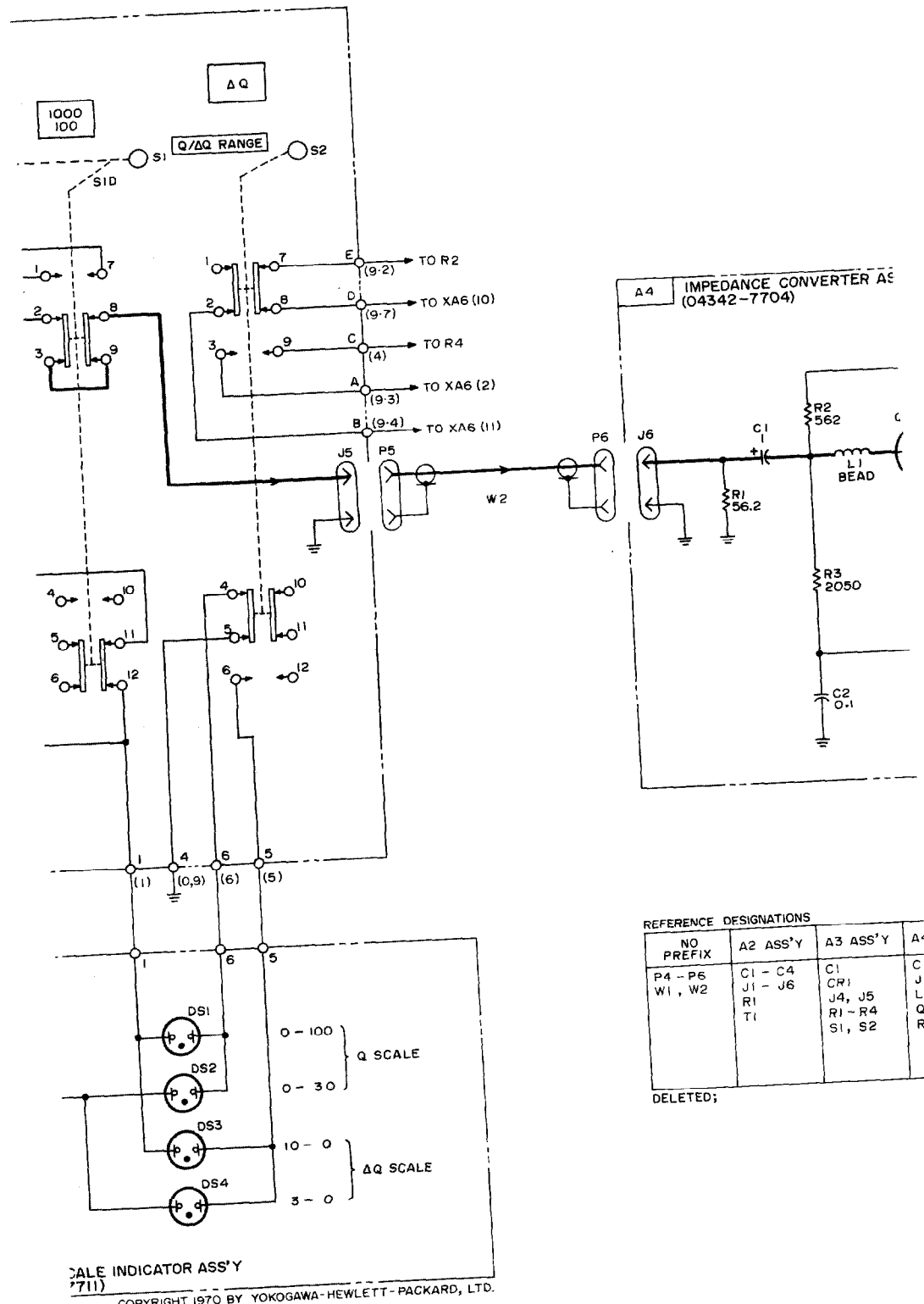

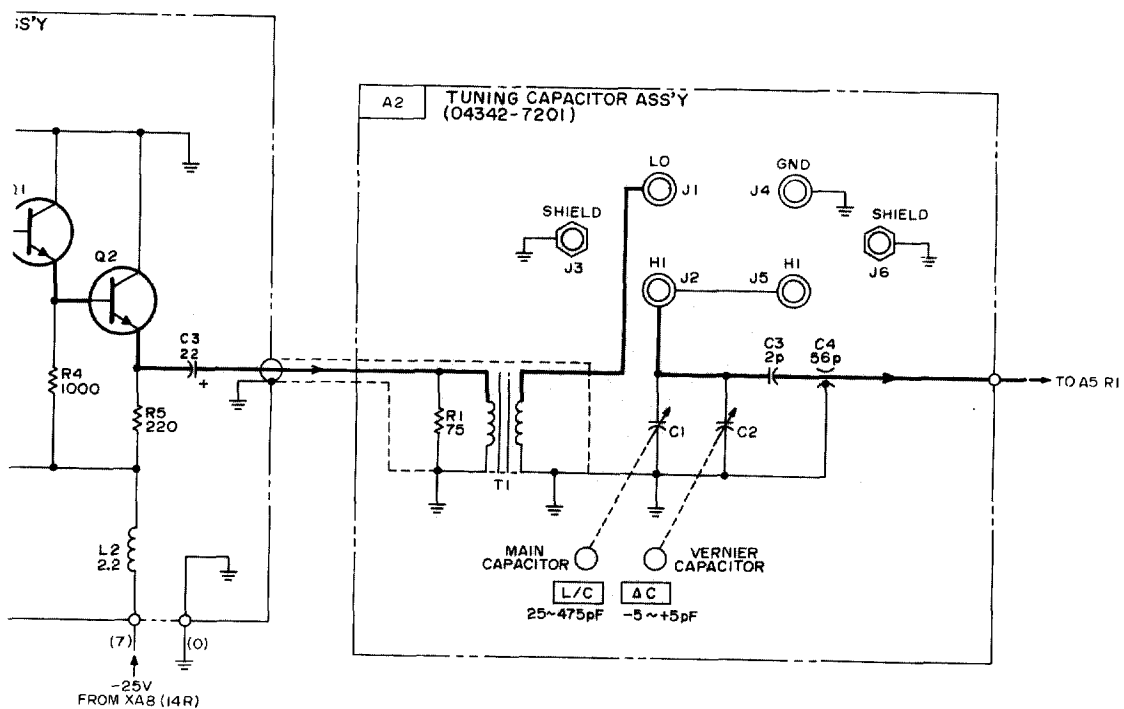

ASS'Y	ALL ASS'Y
1 - C3	DS1 - DS4
1 - L2	
1 - Q2	
1 - R5	

Figure 8-4. Tuning Capacitor Ass'y A2
Q Range Attenuator Ass'y A3
Impedance Converter Ass'y A4
Meter Scale Indicator Ass'y A11

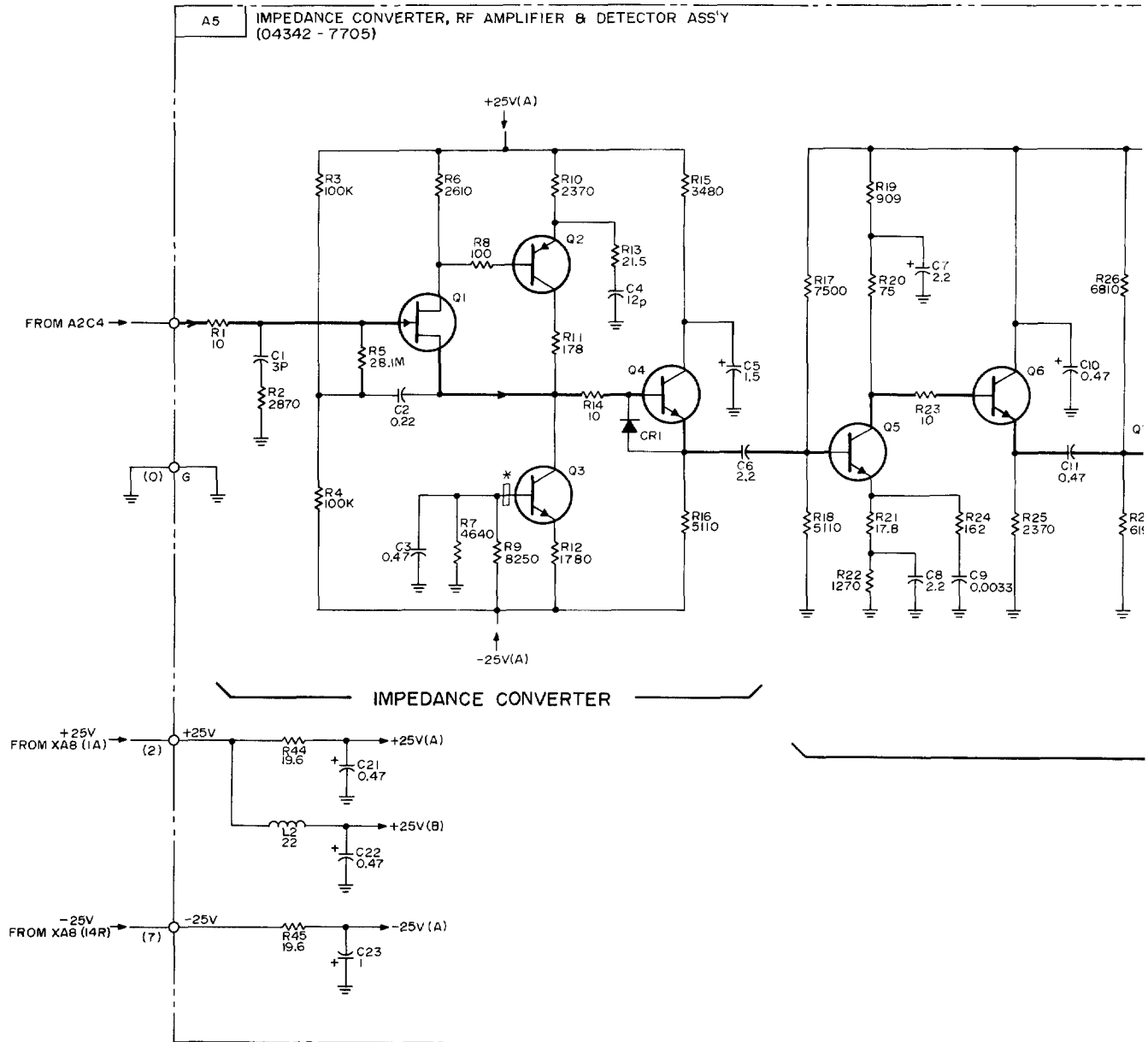

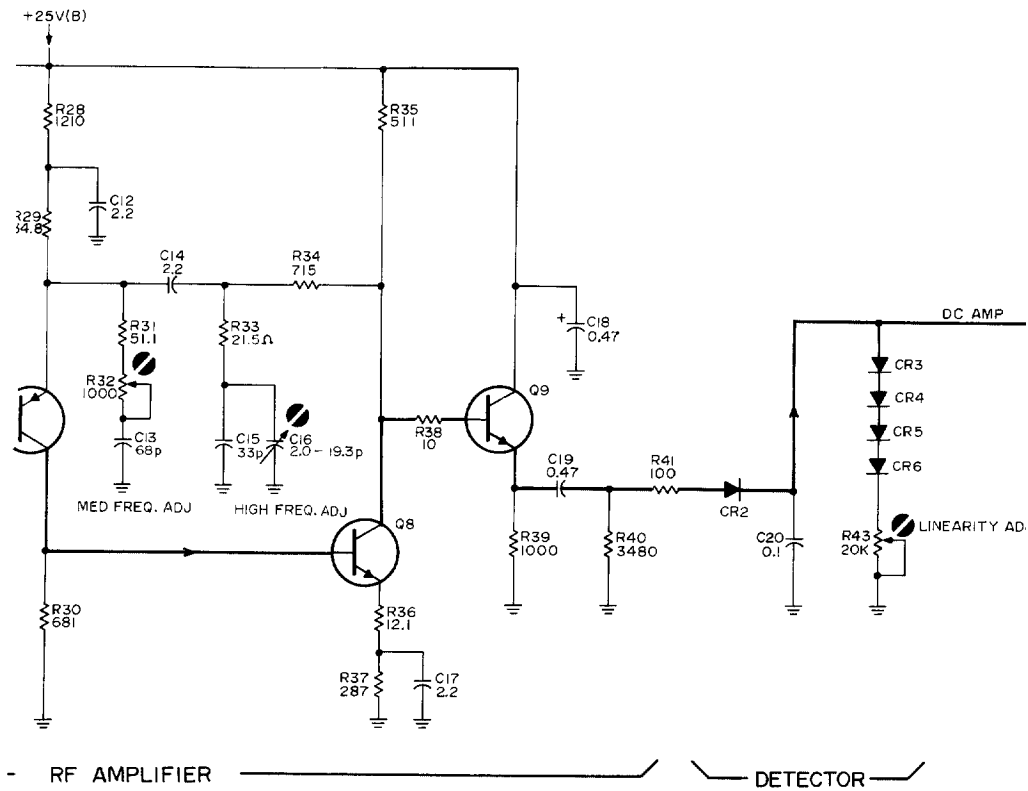

REFERENCE DESIGNATIONS

NO PREFIX	A3 ASS'Y	A5 ASS'Y	A6 ASS'Y	A11 ASS'Y
J1 M1 R2-R4 XA6	S2	C1-C23 CR1-CR6 L2 Q1-Q9 R1-R45	C1-C5 CR1-CR3 L1,L2 Q1-Q5 R1-R29	DS1-DS4

DELETED; A5 L1,L3



SEE INSIDE

	Q RANGE ATTENUATOR	ASS'Y A3
IMPEDANCE CONVERTER, RF AMPLIFIER & DETECTOR		ASS'Y A5
	DC AMPLIFIER	ASS'Y A6
	METER SCALE INDICATOR	ASS'Y A11

Figure 8-5

A6

DC AMPLIFIER ASS'Y
(04342-7706)

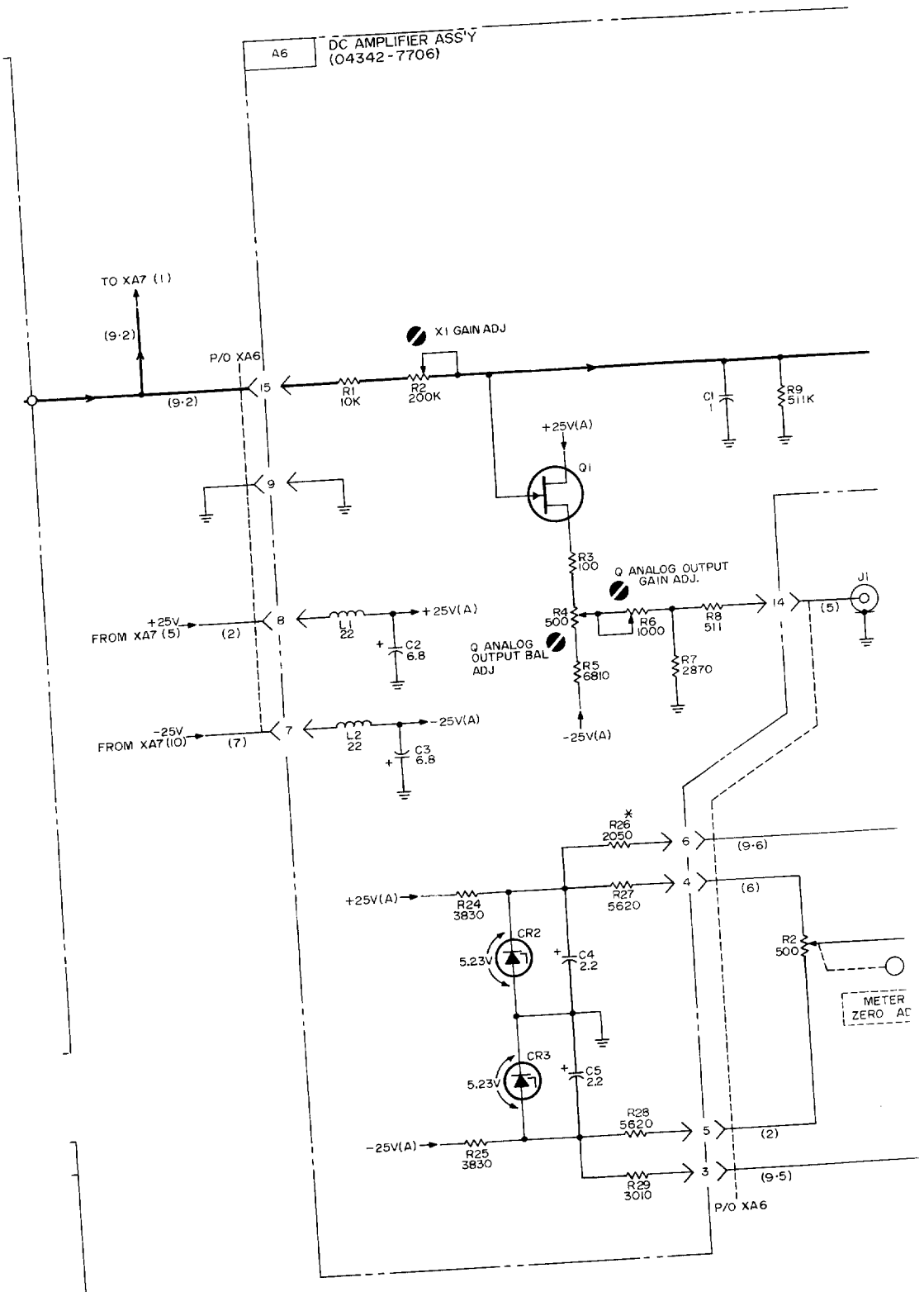

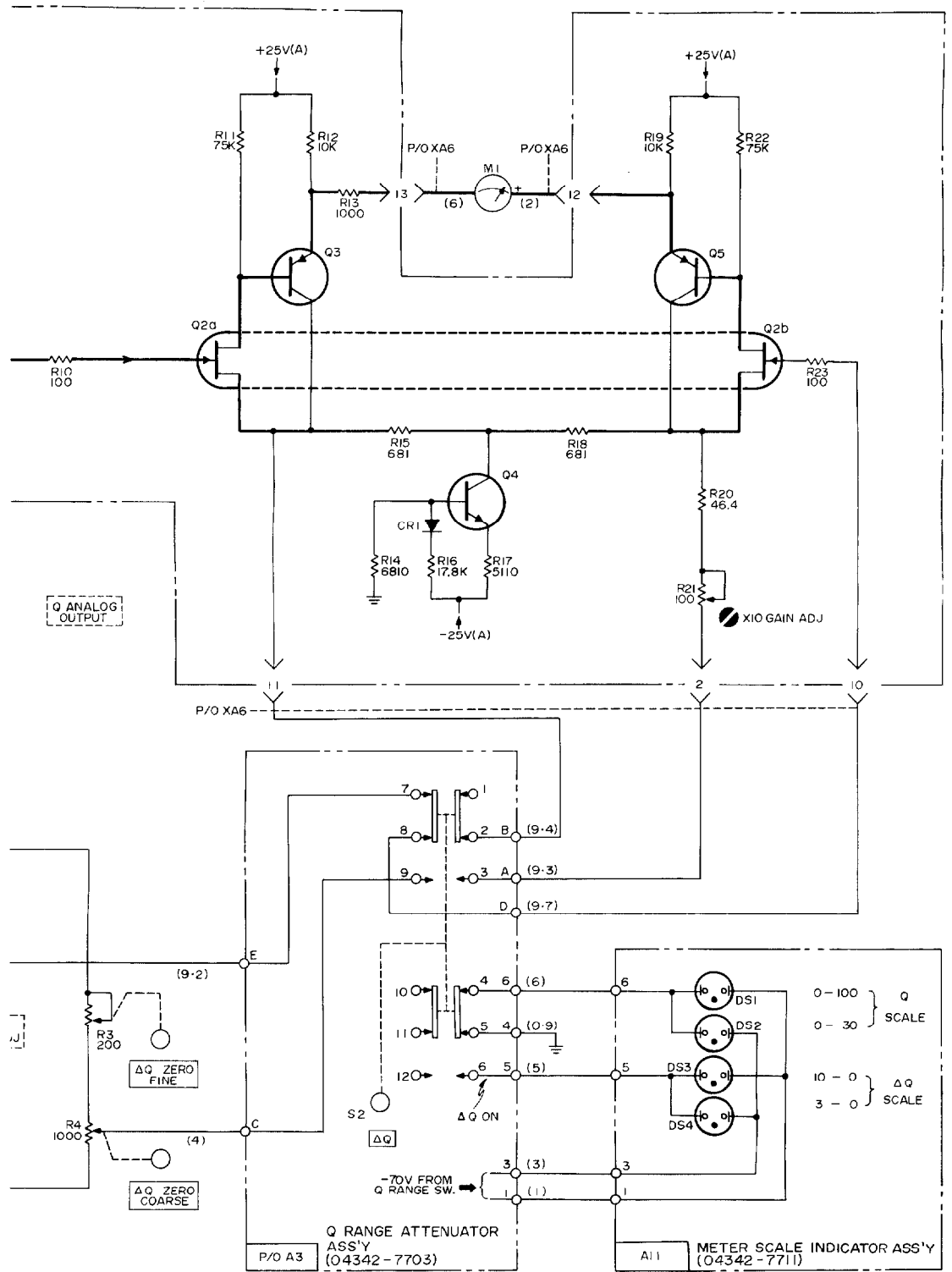

COPYRIGHT 1970 BY YOKOGAWA-HEWLETT-PACKARD, LTD.

Figure 8-5. Q Range Attenuator Ass'y A3
Impedance Converter, RF Amplifier & Detector Ass'y A5
DC Amplifier Ass'y A6
Meter Scale Indicator Ass'y A11

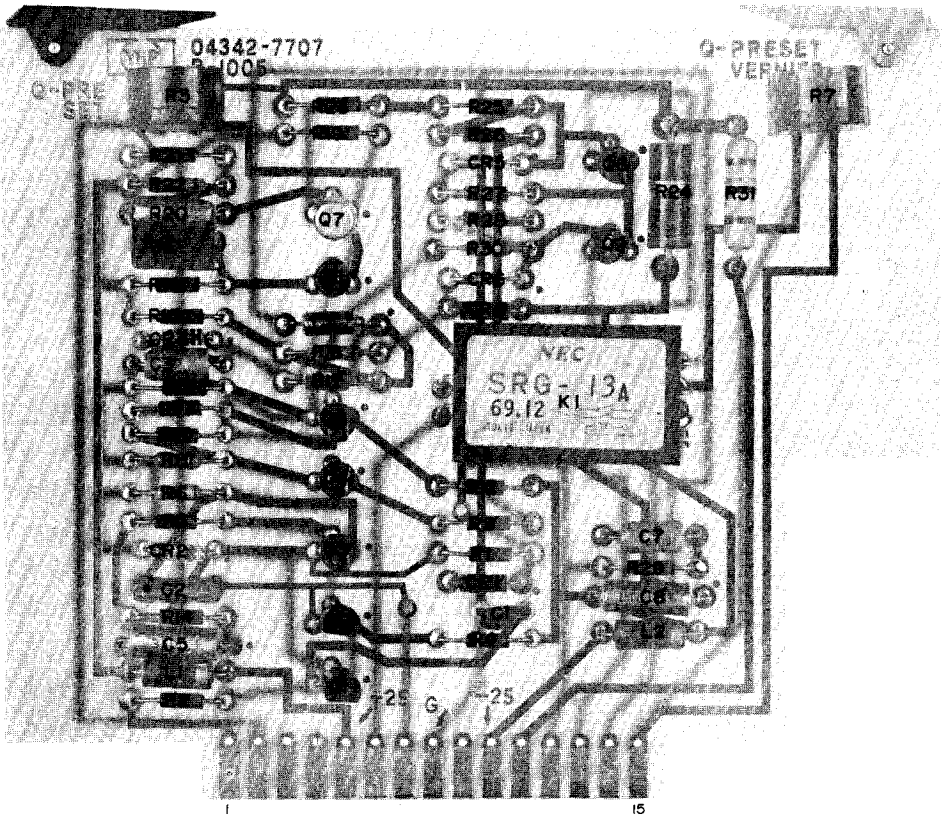

**Q-LIMIT SELECTOR ASS'Y A7
COMPONENT LOCATION**

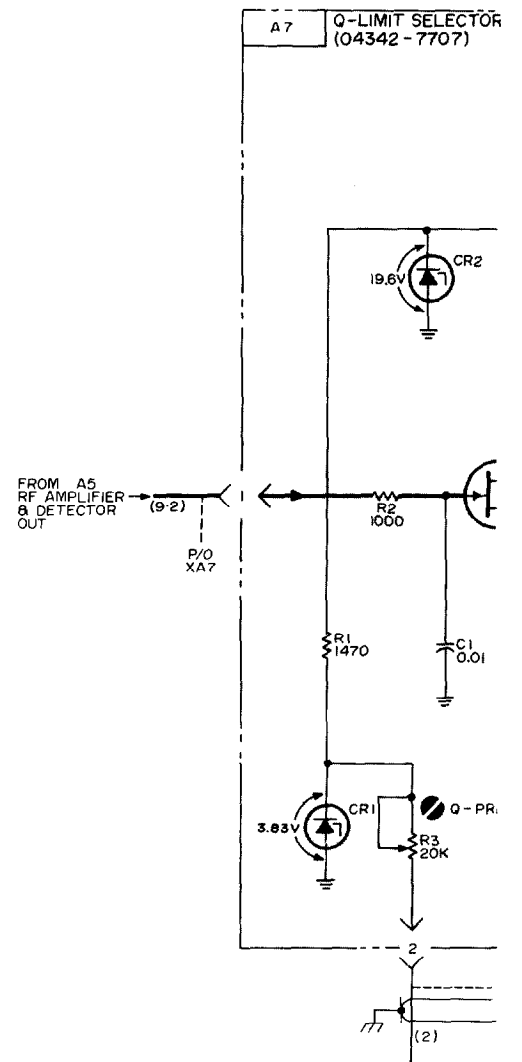



SEE INSIDE

Figure 8-6
Q LIMIT SELECTOR ASS'Y A7
FREQUENCY MULTIPLIER & OVER LIMIT INDICATOR ASS'Y A10

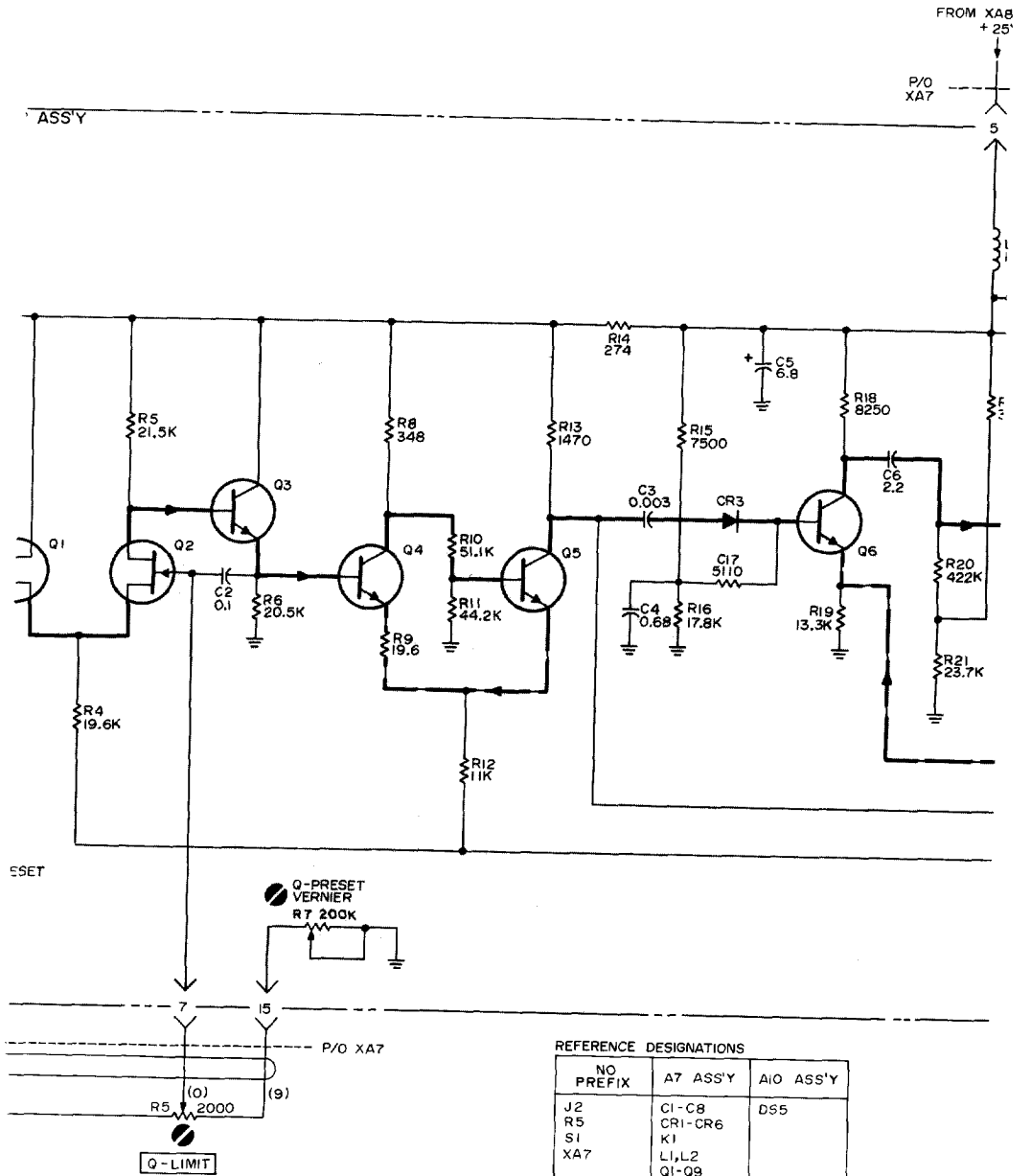

REFERENCE DESIGNATIONS

NO PREFIX	A7 ASS'Y	A10 ASS'Y
J2	C1-C8	D55
R5	CR1-CR6	
S1	K1	
XA7	L1,L2	
	Q1-Q9	
	R1-R31	

DELETED;

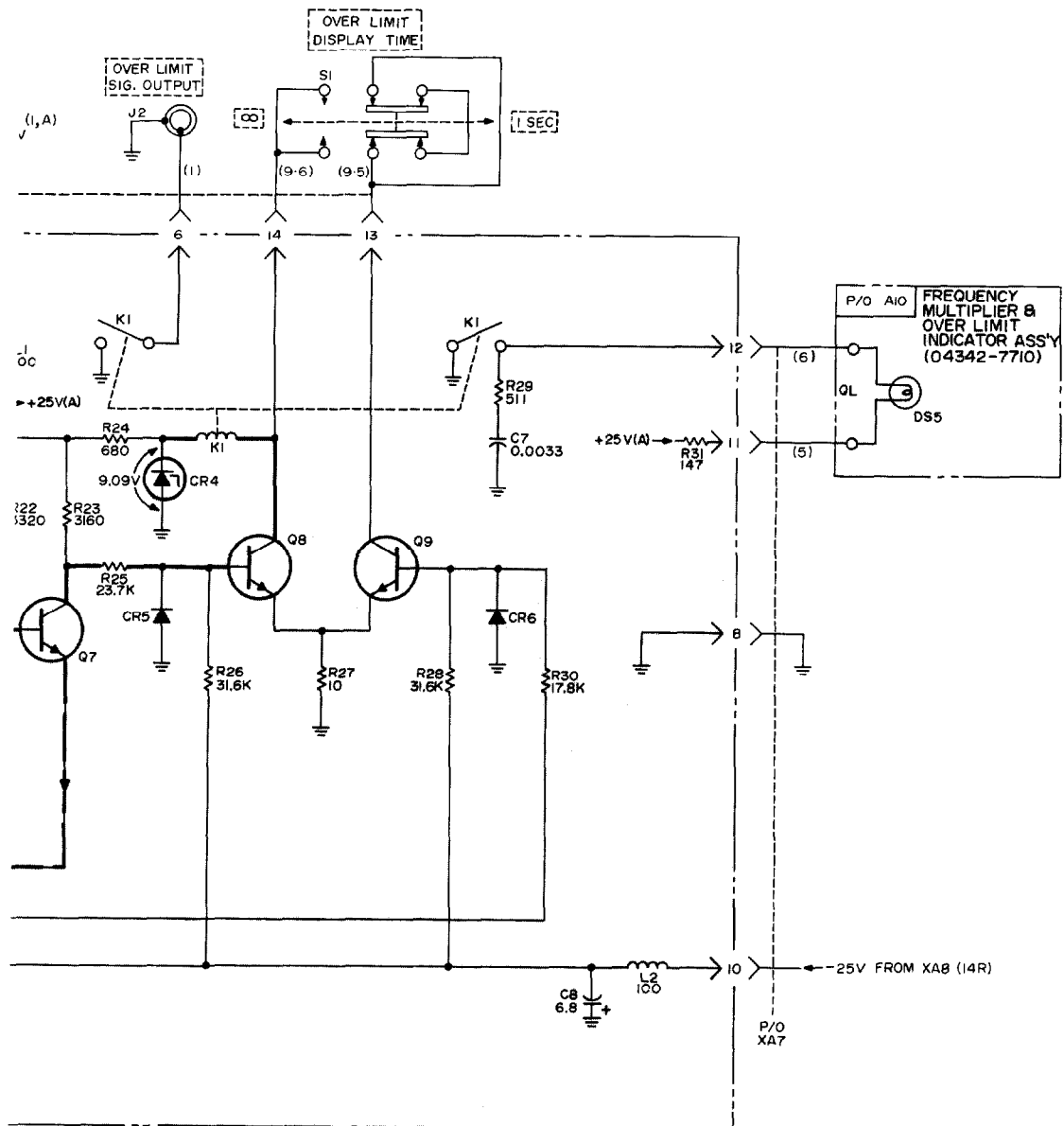

COPYRIGHT 1970 BY YOKOGAWA-HEWLETT-PACKARD, LTD.

Figure 8-6. Q-Limit Selector Ass'y A7
Frequency Multiplier & Over Limit Indicator Ass'y A10

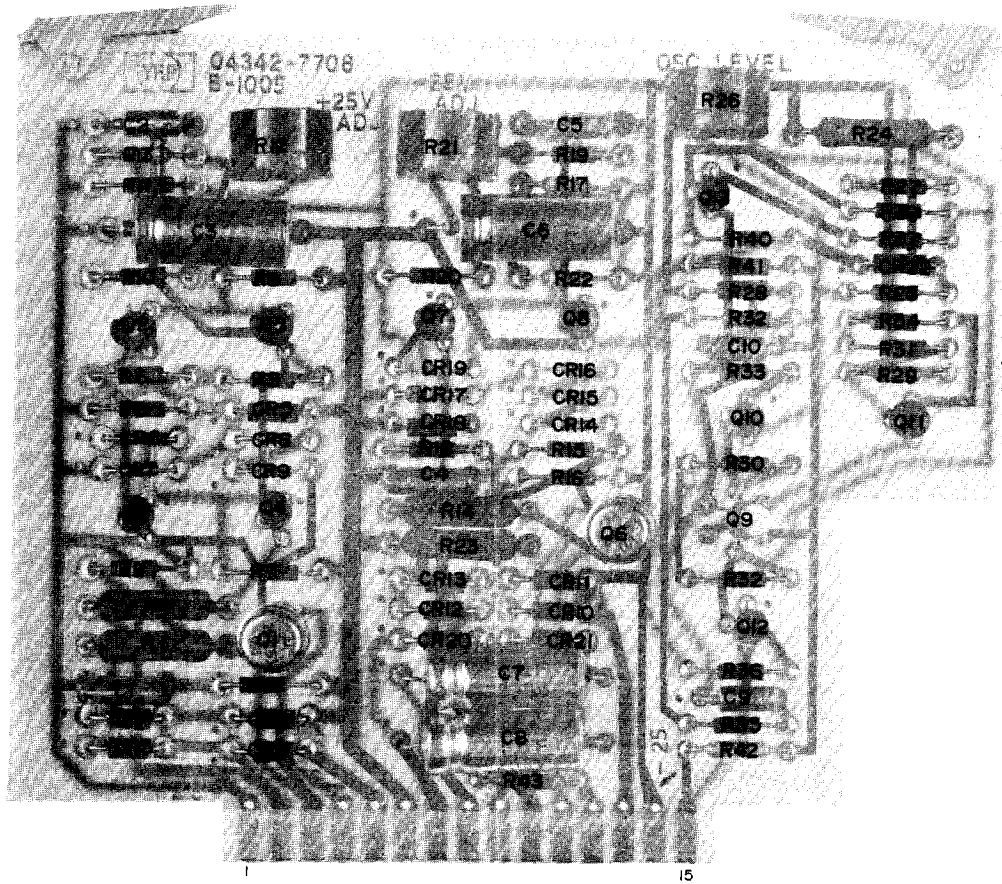

POWER SUPPLY & ALC AMPLIFIER ASS'Y A8
COMPONENT LOCATION

REFEREN

NO
PREF:
C1-C3
F1
J3
L1,L2
Q1,Q2
S2,S3
T1
W3
XAB

DELETED

LINE
PUSH ON/OFF

S2-

(

(

(



SEE INSIDE

POWER SUPPLY & ALC AMPLIFIER ASS'Y A8

Figuer 8-7

8-13

COMPONENT DESIGNATIONS

X	AB ASS'Y
	C1-C8
	CR1-CR21
	Q1-Q8
	R1-R23, R43

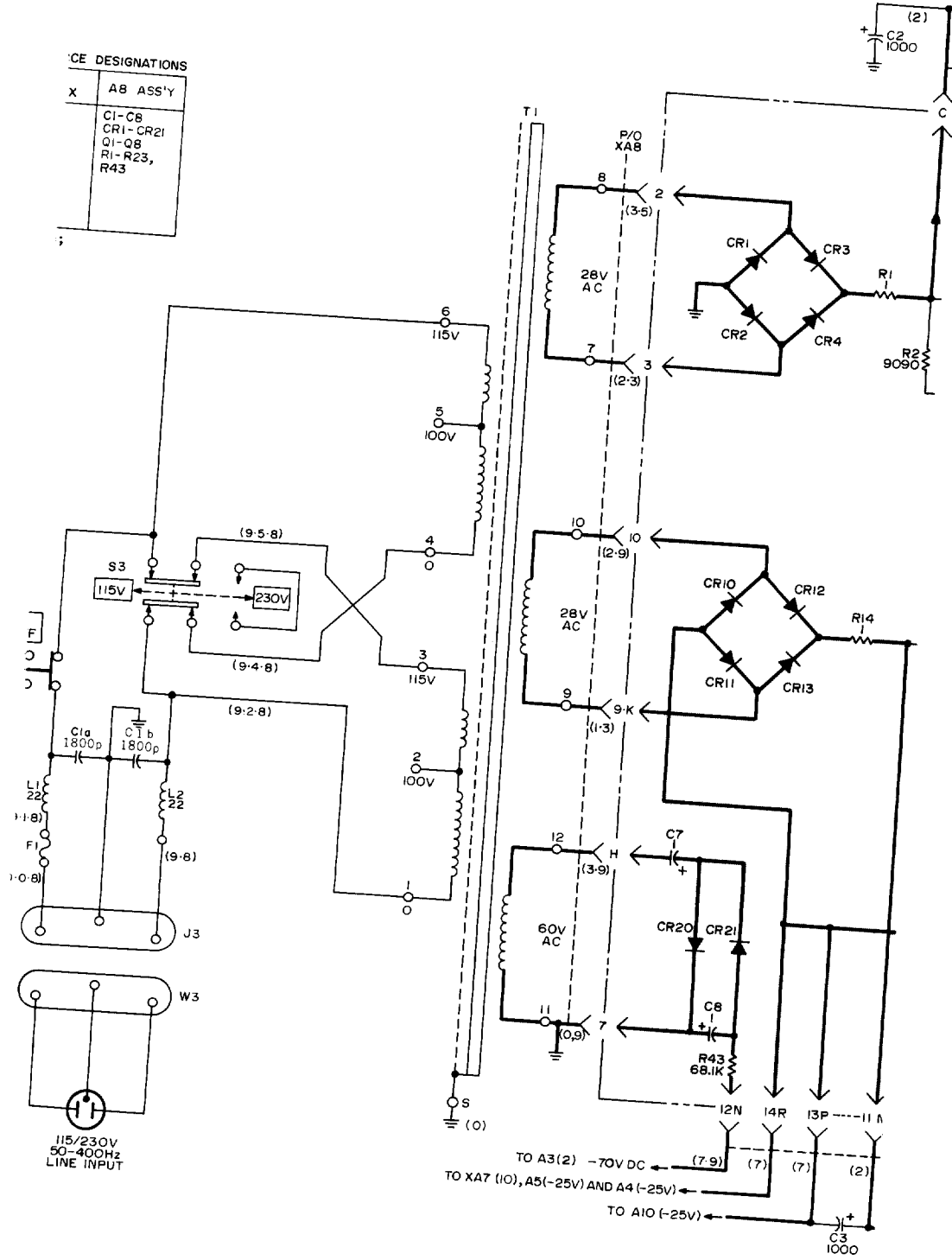

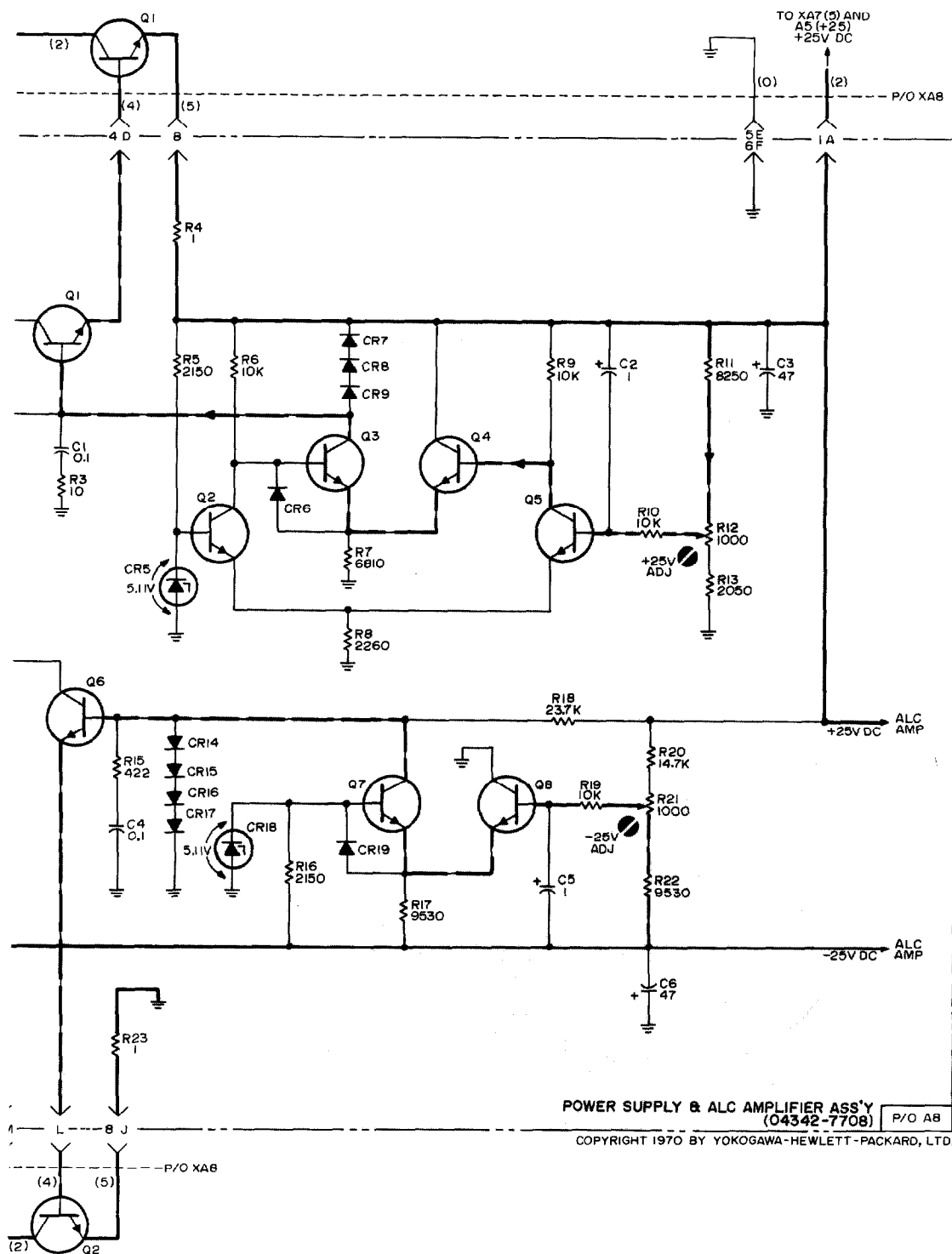

Figure 8-7. Power Supply & ALC Amplifier Ass'y A8

APPENDIX OPTION 001

This manual applies directly to the 4342A Standard Models. To adapt this manual to Option 001 instruments, refer to the followings.

I. REPLACEABLE PARTS

Replace page 6-3 and 6-4, Table 6-2, Reference Designation Index for A1A1 Ass'y with Table A-1.

Replace page 6-11 and 6-12, Table 6-2, Reference Designation Index for A5 Ass'y with Table A-2.

Page 6-21, Table 6-2, Reference Designation Index Miscellaneous
 Change HP Part No. of SCALE:FREQUENCY DIAL to 04342-1060.
 Change HP Part No. of FILM:FREQUENCY RANGE SWITCH to 04342-8554.

II. MANUAL CHANGES

Information in this Appendix applies directly to the 4342A Option 001 instruments with serials 1035/1036J00341 and above. This information with the following changes also applies to the 4342A Option 001 having serials 1035/1036J00340 and below. For other changes except A1A1 and A5 Ass'y, see SECTION VII MANUAL CHANGES AND OPTIONS.

Instrument Serial Prefix or Number	Change No.
1005/1006	1, 2, 3, 4, 5,
1018/1019	2, 3, 4, 5,
1035/1036J00240 and below	3, 4, 5,
1035/1036J00340 and below	4, 5,
1211/1212J02206 and below	5,

CHANGE 1

Page A-4, Table A-1, Reference Designation Index
 Delete A1A1L9.
 Change A1A1R1* to HP Part No. 0757-0422; R:FXD MET FLM 909Ω 1% 1/8W.
 Change A1A1R2* and R3* to HP Part No. 0698-3443; R:FXD MET FLM 287Ω 1% 1/8W.

Page A-7, Figure A-1, Oscillator Ass'y (Option 001) A1
 Delete A1A1L9 from circuit.
 Change value of A1A1R1* to 909Ω.
 Change values of A1A1R2* and R3* to 287Ω.

CHANGE 2

Page A-3, Table A-1, Reference Designation Index,
 Change HP Part No. of A1A1 to 04342-7721.
 Change HP Part No. of A1A1 BLANK PC BOARD to 04342-8721.

Page A-7, Figure A-1, Oscillator Ass'y (Option 001) A1
 Change HP Part No. of A1A1 OSCILLATOR BOARD ASS'Y to 04342-7721.

CHANGE 3

Page A-3, Table A-1, Reference Designation Index

Change A1A1C23* to HP Part No. 0160-2236; C:FXD CER 1pF 500VDCW.

Page A-4, Table A-1, Reference Designation Index

Delete A1A1L10.

Change A1A1R1* to HP Part No. 0698-4398; R:FXD MET FLM 8.66k Ω 1% 1/8W.

Change A1A1R3* to HP Part No. 0698-0083; R:FXD MET FLM 1.96k Ω 1% 1/8W.

Change A1A1R4* to HP Part No. 0698-4460; R:FXD MET FLM 649 Ω 1% 1/8W.

Page A-7, Figure A-1, Oscillator Ass'y (Option 001) A1

Change value of A1A1C23* to 1pF.

Delete A1A1L10 from circuit.

Change value of A1A1R1* to 8.66k Ω .

Change value of A1A1R3* to 1.96k Ω .

Change value of A1A1R4* to 649 Ω .

Page A-5, Table A-2, Reference Designation Index

Change A5C13 to HP Part No. 0140-0205; C:FXD MICA 62pF 5%, and remove asterisk (*) from A5C13.

Change A5C15 to HP Part No. 0160-2262; C:FXD CER 16pF 5%, and remove asterisk (*) from A5C15.

Change A5C16 to HP Part No. 0121-0146; C:VAR AIR 1.8-16.7pF.

Page A-9, Figure A-2, Impedance Converter, RF Amplifier and Detector Ass'y (Option 001) A5

Change value of A5C13 to 62pF, and remove asterisk (*) from A5C13.

Change value of A5C15 to 16pF, and remove asterisk (*) from A5C15.

Change value of A5C16 to 1.8-16.7pF.

CHANGE 4

Page A-5, Table A-2, Reference Designation Index

Change A5C13* to HP Part No. 0160-2202; C:FXD MICA 75pF 5% 300VDCW.

Change A5C15* to HP Part No. 0140-0190; C:FXD MICA 39pF 5% 300VDCW.

Change A5R33 to HP Part No. 0698-3433; R:FXD MET FLM 28.7 Ω 1% 1/8W.

Change A5R42 to HP Part No. 0757-0442; R:FXD MET FLM 10k Ω 1% 1/8W.

Page A-9, Figure A-2, Impedance Converter & RF Amplifier and Detector Ass'y (Option 001) A5

Change value of A5C13* to 75pF.

Change value of A5C15* to 39pF.

Change value of A5R33 to 28.7 Ω .

Change value of A5R42 to 10k Ω .

CHANGE 5

Page A-6, Table A-2, Reference Designation Index

Change the part number of A5R5 to 0730-0149.

III. CIRCUIT DIAGRAMS

Circuit diagrams of Oscillator Ass'y (Option 001) A1 and Impedance Converter, RF Amplifier and Detector Ass'y (Option 001) A5 are given in Figure A-1 and A-2. For other assemblies, see SECTION VIII CIRCUIT DIAGRAMS.

Table A-1. Reference Designation Index

Reference Designation	Part No.	Description	Note
A1	04342-7120 04342-5001 04342-1070 04342-1171	OSCILLATOR ASS'Y (OPTION 001) CASE:OSCILLATOR COVER:TOP COVER:BOTTOM	
A1A1	04342-7761 04342-8761	OSCILLATOR BOARD ASS'Y (OPTION 001) BOARD:BLANK PC	
A1A1C1	0121-0236	C:VAR CER CYLINDER 0.8 - 8.5pF	
A1A1C2*	0160-2244	C:FXD CER 3.0pF ± 0.25 pF 500VDCW	
A1A1C3	0121-0236	C:VAR CER CYLINDER 0.8 - 8.5pF	
A1A1C4*	0160-2250	C:FXD CER 5.1pF ± 0.25 pF 500VDCW	
A1A1C5	0121-0236	C:VAR CER CYLINDER 0.8 - 8.5pF	
A1A1C6*	0160-2252	C:FXD CER 6.2pF ± 0.25 pF 500VDCW	
A1A1C7	0121-0236	C:VAR CER CYLINDER 0.8 - 8.5pF	
A1A1C8*	0160-2253	C:FXD CER 6.8pF ± 0.25 pF 500VDCW	
A1A1C9	0121-0236	C:VAR CER CYLINDER 0.8 - 8.5pF	
A1A1C10*	0160-2248	C:FXD CER 4.3pF ± 0.25 pF 500VDCW	
A1A1C11	0121-0236	C:VAR CER CYLINDER 0.8 - 8.5pF	
A1A1C12*	0160-2256	C:FXD CER 9.1pF ± 0.25 pF 500VDCW	
A1A1C13	0121-0236	C:VAR CER CYLINDER 0.8 - 8.5pF	
A1A1C14*		NORMALLY OPEN	
A1A1C15		NOT ASSIGNED	
A1A1C16		NOT ASSIGNED	
A1A1C17	0180-1743	C:FXD TA 0.1 μ F 10% 35VDCW	
A1A1C19	0160-0417	C:FXD CER 150pF 10% 500VDCW	
A1A1C20	0121-0232	C:VAR AIR 12 - 460pF	
A1A1C21	0160-2238	C:FXD CER 1.5pF 500VDCW	
A1A1C22	0180-0291	C:FXD TA 1 μ F 10% 35VDCW	
A1A1C23*	0150-0059	C:FXD CER 3.3pF 500VDCW	
A1A1C24	0180-0116	C:FXD TA 6.8 μ F 10% 35VDCW	
A1A1C25		NOT ASSIGNED	
A1A1C26	0180-0291	C:FXD TA 1 μ F 10% 35VDCW	
A1A1C27	0180-0116	C:FXD TA 6.8 μ F 10% 35VDCW	
A1A1C28		NOT ASSIGNED	
A1A1C29		NOT ASSIGNED	
A1A1C30	0180-0116	C:FXD TA 6.8 μ F 10% 35VDCW	
A1A1C31	0150-0093	C:FXD CER 0.01 μ F -20% +80% 100VDCW	
A1A1L1	04342-8610	COIL:VAR 500 - 700mH	
A1A1L2	04342-8611	COIL:VAR 51 - 78mH	
A1A1L3	04342-8612	COIL:VAR 4.7 - 7.2mH	
A1A1L4	04342-8613	COIL:VAR 486 - 740 μ H	
A1A1L5	04342-8614	COIL:VAR 49 - 71.3 μ H	

Table A-1. Reference Designation Index (Cont'd)

Reference Designation	Part No.	Description	Note
A1A1L6	04342-8615	COIL:VAR 5 - 6 μ H	
A1A1L7	04342-8620	COIL:VAR 0.41 - 0.55 μ H	
A1A1L9	9170-0029	MAGNETIC CORE:BEAD FERRITE	
A1A1L9	9170-0029	MAGNETIC CORE:BEAD FERRITE	
A1A1L10	9170-0029	MAGNETIC CORE:BEAD FERRITE	
A1A1Q1	1854-0071	TRANSISTOR:NPN SILICON	
A1A1Q2	1854-0092	TRANSISTOR:NPN SILICON	
A1A1Q3	1855-0022	TRANSISTOR:FIELD EFFECT N-CHANNEL	
A1A1Q4	1853-0034	TRANSISTOR:PNP SILICON	
A1A1Q5	1854-0019	TRANSISTOR:NPN SILICON	
A1A1Q6	1854-0019	TRANSISTOR:NPN SILICON	
A1A1R1*	0757-0288	R:FXD MET FLM 9.09k Ω 1% 1/8W	
A1A1R2*	0757-0273	R:FXD MET FLM 3.01k Ω 1% 1/8W	
A1A1R3*	0698-4431	R:FXD MET FLM 2.05k Ω 1% 1/8W	
A1A1R4*	0757-0419	R:FXD MET FLM 681 Ω 1% 1/8W	
A1A1R5*	0757-0317	R:FXD MET FLM 1.33k Ω 1% 1/8W	
A1A1R6*	0698-3447	R:FXD MET FLM 422 Ω 1% 1/8W	
A1A1R7*	0698-3243	R:FXD MET FLM 178k Ω 1% 1/8W	
A1A1R8*	0757-0290	R:FXD MET FLM 6.19k Ω 1% 1/8W	
A1A1R9	0698-3359	R:FXD MET FLM 12.7k Ω 1% 1/8W	
A1A1R10	0757-0279	R:FXD MET FLM 3.16k Ω 1% 1/8W	
A1A1R11	0698-3156	R:FXD MET FLM 14.7k Ω 1% 1/8W	
A1A1R12	0683-2265	R:FXD COMP 22M Ω 5% 1/4W	
A1A1R13	0757-0123	R:FXD MET FLM 34.8k Ω 1% 1/8W	
A1A1R14	0757-0442	R:FXD MET FLM 10k Ω 1% 1/8W	
A1A1R15	0698-3156	R:FXD MET FLM 14.7k Ω 1% 1/8W	
A1A1R16	0698-3153	R:FXD MET FLM 3.83k Ω 1% 1/8W	
A1A1R17	0698-3151	R:FXD MET FLM 2.87k Ω 1% 1/8W	
A1A1R18	0698-4453	R:FXD MET FLM 402 Ω 1% 1/8W	
A1A1R19	0698-4125	R:FXD MET FLM 953 Ω 1% 1/8W	
A1A1R20*	0757-0401	R:FXD MET FLM 100 Ω 1% 1/8W	
A1A1R21	0757-0821	R:FXD MET FLM 1.21k Ω 1% 1/2W	
A1A1R22	0757-0346	R:FXD MET FLM 10 Ω 1% 1/8W	
A1A1R30	0757-0284	R:FXD MET FLM 150 Ω 1% 1/8W	
A1A1S1	3101-0260	SWITCH:PUSH BUTTON 7-RANGE	
A1A1XA1A2	1251-0478	CONNECTOR:PRINTED CIRCUIT 12-CONTACT	
	04342-1074	MISCELLANEOUS PLATE:ANGLE	
	04342-3022	NUT:HEX FOR FERRITE CORE	

Table A-2. Reference Designation Index

Reference Designation	Part No.	Description	Note
A5	04342-7725 04342-8725	IMPEDANCE CONVERTER & RF AMPLIFIER ASS'Y (OPTION 001) BOARD:BLANK PC	
A5C1	0160-2244	C:FXD CER 3pF ±0.25pF	
A5C2	0180-1735	C:FXD TA 0.22µF 10% 35VDCW	
A5C3	0180-0376	C:FXD TA 0.47µF 10% 35VDCW	
A5C4	0160-2259	C:FXD CER 12pF 5%	
A5C5	0180-1745	C:FXD TA 1.5µF 10% 20VDCW	
A5C6	0160-0128	C:FXD CER 2.2µF 20% 25VDCW	
A5C7	0180-0116	C:FXD TA 6.8µF 10% 35VDCW	
A5C8	0180-1746	C:FXD TA 15µF 10% 20VDCW	
A5C9	0160-0155	C:FXD MY 0.0033µF 10% 200VDCW	
A5C10	0180-0376	C:FXD TA 0.47µF 10% 35VDCW	
A5C11	0160-0174	C:FXD CER 0.47µF -20% +80% 25VDCW	
A5C12	0180-0116	C:FXD TA 6.8µF 10% 35VDCW	
A5C13*	0140-0192	C:FXD MICA 68pF 5% 300VDCW	
A5C14	0160-0128	C:FXD CER 2.2µF 20% 25VDCW	
A5C15*	0160-2150	C:FXD MICA 33pF 5% 300VDCW	
A5C16*	0121-0147	C:VAR AIR 2.0 - 19.3pF	
A5C17	0160-0128	C:FXD CER 2.2µF 20% 25VDCW	
A5C18	0180-0376	C:FXD TA 0.47µF 10% 35VDCW	
A5C19	0160-0174	C:FXD CER 0.47µF -20% +80% 25VDCW	
A5C20	0150-0121	C:FXD CER 0.1µF -20% +80% 50VDCW	
A5C21	0180-0376	C:FXD TA 0.47µF 10% 35VDCW	
A5C22	0180-0376	C:FXD TA 0.47µF 10% 35VDCW	
A5C23	0180-0291	C:FXD TA 1µF 10% 35VDCW	
A5CR1	1901-0025	SEMICON DEVICE:DIODE SILICON	
A5CR2	1910-0016	SEMICON DEVICE:DIODE GERMANIUM	
A5CR3	1910-0016	SEMICON DEVICE:DIODE GERMANIUM	
A5CR4	1910-0016	SEMICON DEVICE:DIODE GERMANIUM	
A5CR5	1910-0016	SEMICON DEVICE:DIODE GERMANIUM	
A5CR6	1910-0016	SEMICON DEVICE:DIODE GERMANIUM	
A5L1	9140-0179	COIL:FXD RF 22µH 10%	
A5L2	9140-0179	COIL:FXD RF 22µH 10%	
A5L3	9140-0137	COIL:FXD RF 1000µH 10%	
A5Q1	1855-0022	TRANSISTOR:FIELD EFFECT N-CHANNEL	
A5Q2	1853-0015	TRANSISTOR:PNP SILICON 2N3640	
A5Q3	1854-0023	TRANSISTOR:NPN SILICON	
A5Q4	1854-0092	TRANSISTOR:NPN SILICON 2N3563	
A5Q5	1854-0296	TRANSISTOR:NPN SILICON MPS6543	
A5Q6	1854-0092	TRANSISTOR:NPN SILICON 2N3563	
A5Q7	1853-0015	TRANSISTOR:PNP SILICON 2N3640	
A5Q8	1854-0233	TRANSISTOR:NPN SILICON 2N3866	
A5Q9	1854-0091	TRANSISTOR:NPN SILICON	

Table A-2. Reference Designation Index (Cont'd)

Reference Designation	Part No.	Description	Note
A5R1	0757-0346	R:FXD MET FLM 10Ω 1% 1/8W	
A5R2	0698-3151	R:FXD MET FLM 2.87kΩ 1% 1/8W	
A5R3	0757-0465	R:FXD MET FLM 100kΩ 1% 1/8W	
A5R4	0757-0465	R:FXD MET FLM 100kΩ 1% 1/8W	
A5R5	0730-2335	R:FXD C FLM 28.1MΩ 0.5% 1W	
A5R6	0698-0085	R:FXD MET FLM 2.61kΩ 1% 1/8W	
A5R7	0698-3155	R:FXD MET FLM 4.64kΩ 1% 1/8W	
A5R8	0757-0401	R:FXD MET FLM 100Ω 1% 1/8W	
A5R9	0757-0441	R:FXD MET FLM 8.25kΩ 1% 1/8W	
A5R10	0698-3150	R:FXD MET FLM 2.37kΩ 1% 1/8W	
A5R11	0698-3439	R:FXD MET FLM 178Ω 1% 1/8W	
A5R12	0698-0089	R:FXD MET FLM 1.78kΩ 1% 1/2W	
A5R13	0698-3430	R:FXD MET FLM 21.5Ω 1% 1/8W	
A5R14	0757-0346	R:FXD MET FLM 10Ω 1% 1/8W	
A5R15	0698-3152	R:FXD MET FLM 3.48kΩ 1% 1/8W	
A5R16	0757-0438	R:FXD MET FLM 5.11kΩ 1% 1/8W	
A5R17	0757-0440	R:FXD MET FLM 7.5kΩ 1% 1/8W	
A5R18	0757-0438	R:FXD MET FLM 5.11kΩ 1% 1/8W	
A5R19	0757-0422	R:FXD MET FLM 909Ω 1% 1/8W	
A5R20	0757-0398	R:FXD MET FLM 75Ω 1% 1/8W	
A5R21	0757-0294	R:FXD MET FLM 17.8Ω 1% 1/8W	
A5R22	0698-4422	R:FXD MET FLM 1.27kΩ 1% 1/8W	
A5R23	0757-0346	R:FXD MET FLM 10Ω 1% 1/8W	
A5R24	0757-0405	R:FXD MET FLM 162Ω 1% 1/8W	
A5R25	0698-3409	R:FXD MET FLM 2.37kΩ 1% 1/2W	
A5R26	0757-0439	R:FXD MET FLM 6.81kΩ 1% 1/8W	
A5R27	0757-0290	R:FXD MET FLM 6.19kΩ 1% 1/8W	
A5R28	0757-0274	R:FXD MET FLM 1.21kΩ 1% 1/8W	
A5R29	0698-3434	R:FXD MET FLM 34.8Ω 1% 1/8W	
A5R30	0757-0419	R:FXD MET FLM 681Ω 1% 1/8W	
A5R31	0757-0394	R:FXD MET FLM 51.1Ω 1% 1/8W	
A5R32	2100-1986	R:VAR MET FLM 1kΩ 10% 1/2W	
A5R33	0698-3430	R:FXD MET FLM 21.5Ω 1% 1/8W	
A5R34	0698-3700	R:FXD MET FLM 715Ω 1% 1/8W	
A5R35	0757-0814	R:FXD MET FLM 511Ω 1% 1/2W	
A5R36	0757-0379	R:FXD MET FLM 12.1Ω 1% 1/8W	
A5R37	0757-1092	R:FXD MET FLM 287Ω 1% 1/2W	
A5R38	0757-0346	R:FXD MET FLM 10Ω 1% 1/8W	
A5R39	0757-0159	R:FXD MET FLM 1kΩ 1% 1/2W	
A5R40	0698-3152	R:FXD MET FLM 3.48kΩ 1% 1/8W	
A5R41	0757-0401	R:FXD MET FLM 100Ω 1% 1/8W	
A5R43	2100-1777	R:VAR WW 20kΩ 5% 1W	
	0340-0008	MISCELLANEOUS INSULATOR-STAND OFF 2 REQ'D	

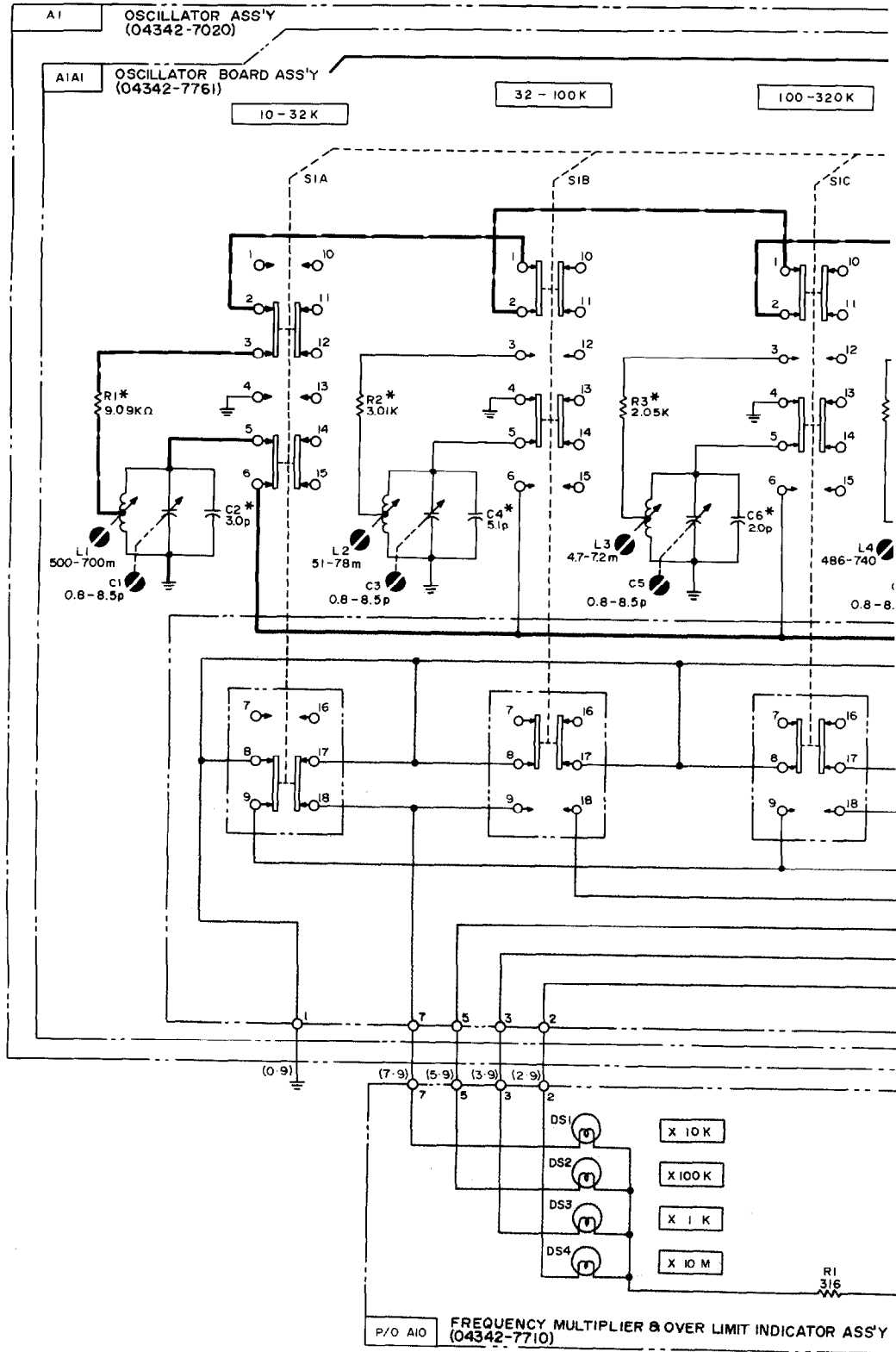

L - C OSCILLATOR

320-1000 K

1 - 3.2 M

3.2-10 M

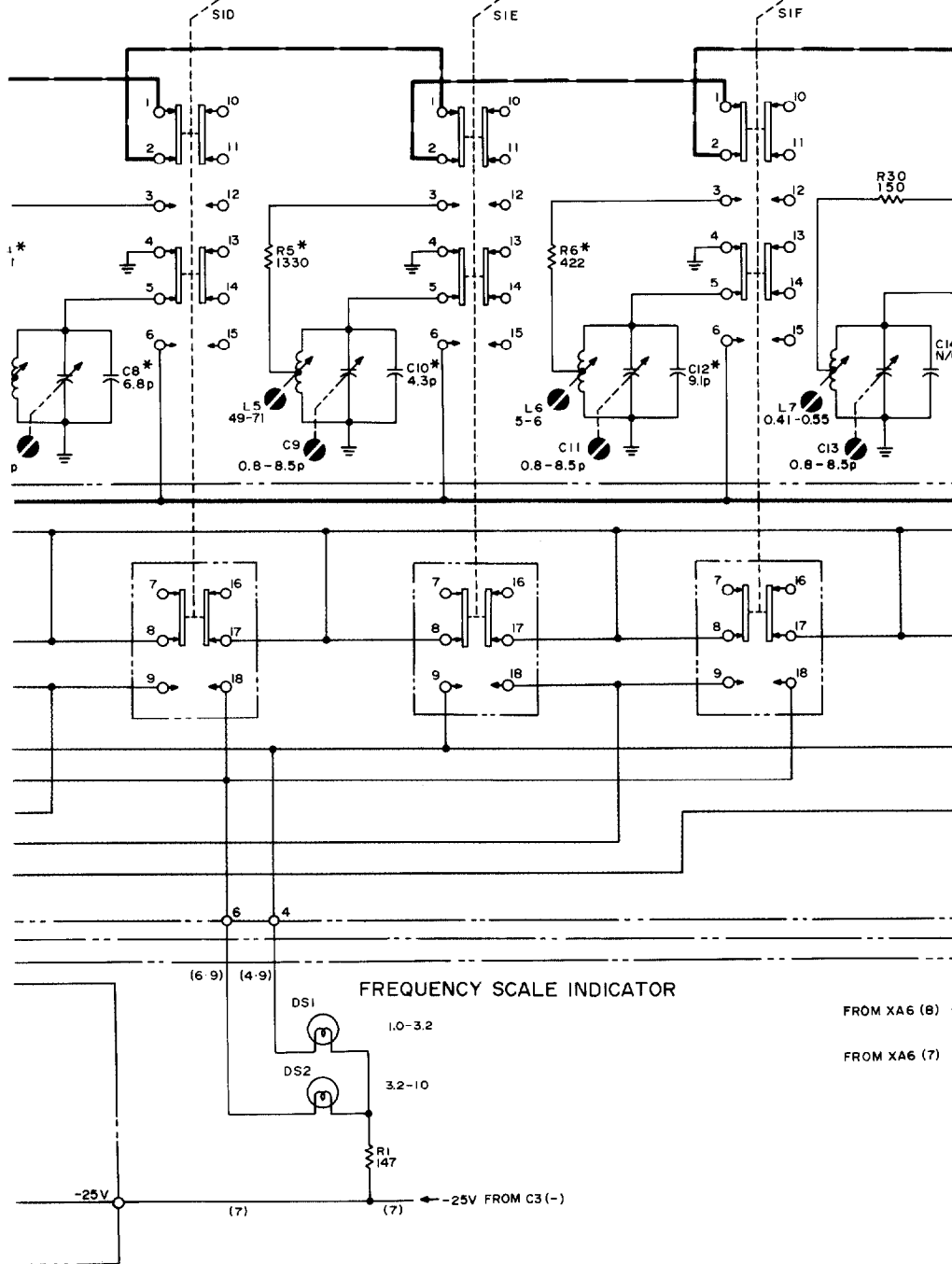



SEE INSIDE

Figure A-1
OSCILLATOR ASS'Y(OPTION 001) AI
FREQUENCY MULTIPLIER & OVER LIMIT INDICATOR ASS'Y AIO

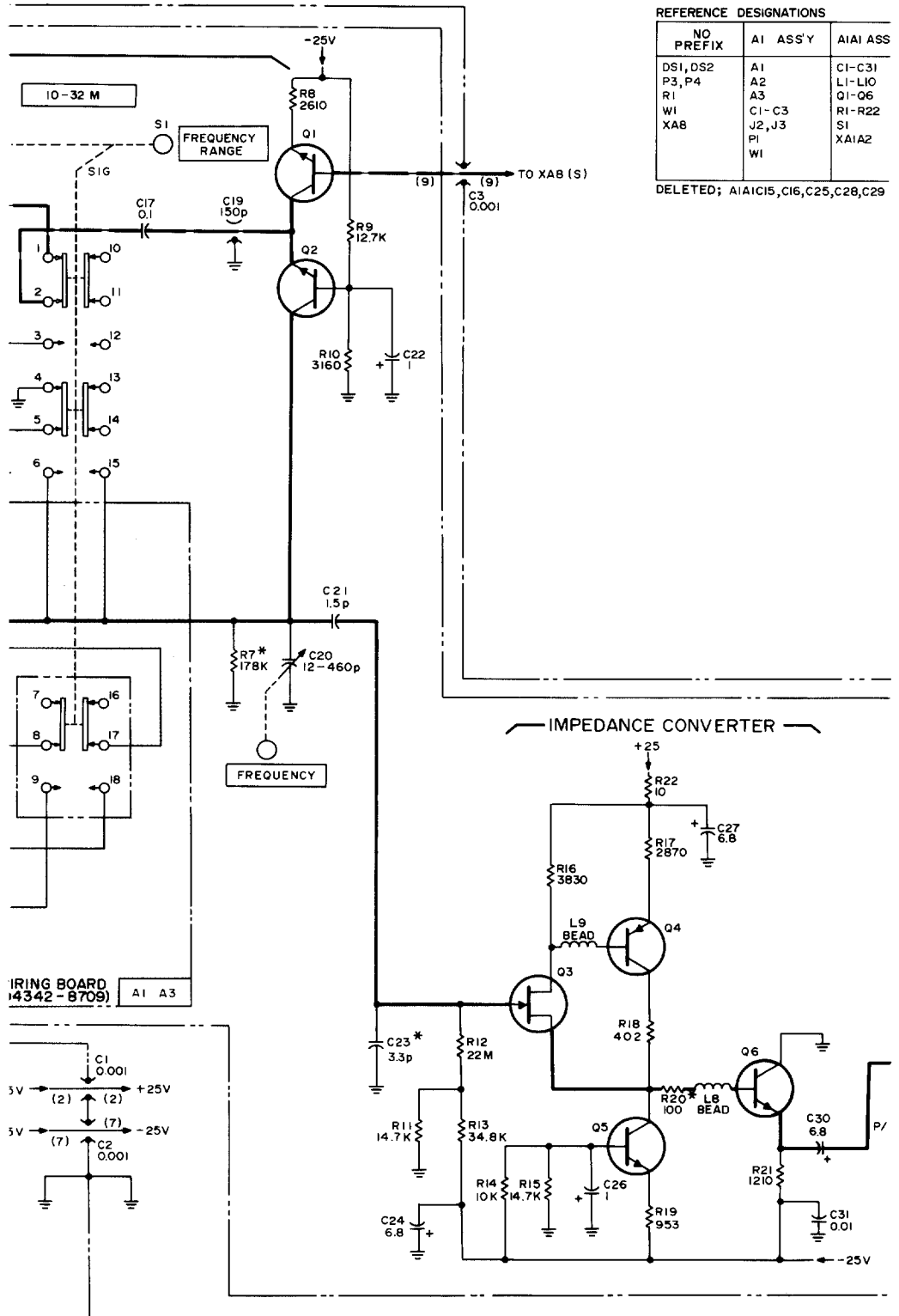

REFERENCE DESIGNATIONS

NO PREFIX	A1 ASS'Y	A1A1 ASS
DS1, DS2	A1	C1-C31
P3, P4	A2	L1-L10
R1	A3	Q1-Q6
W1	C1-C3	R1-R22
XAB	J2, J3	S1
	PI	XA1A2
	W1	

DELETED; A1A1C15, C16, C25, C28, C29

Y	A1A2 ASS'Y	A10 ASS'Y
	C1-C7 J1 L1-L4 Q1-Q4 R1-R13	DS1-DS4 R1

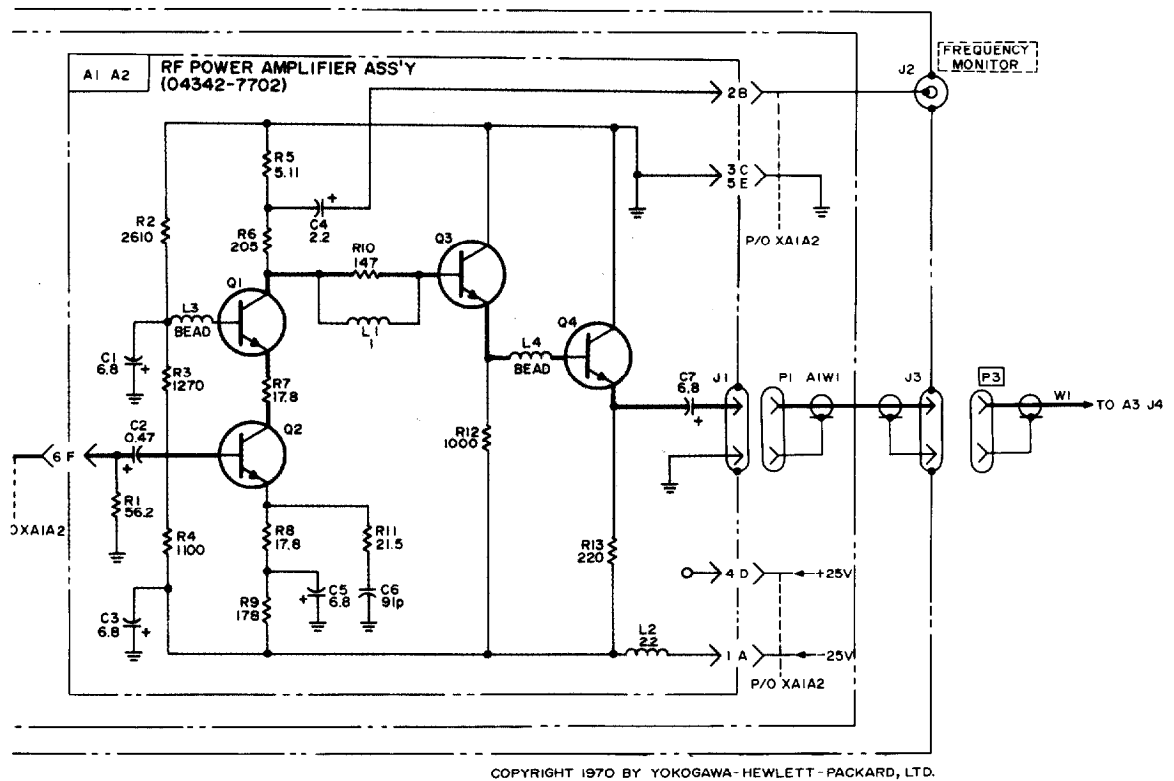
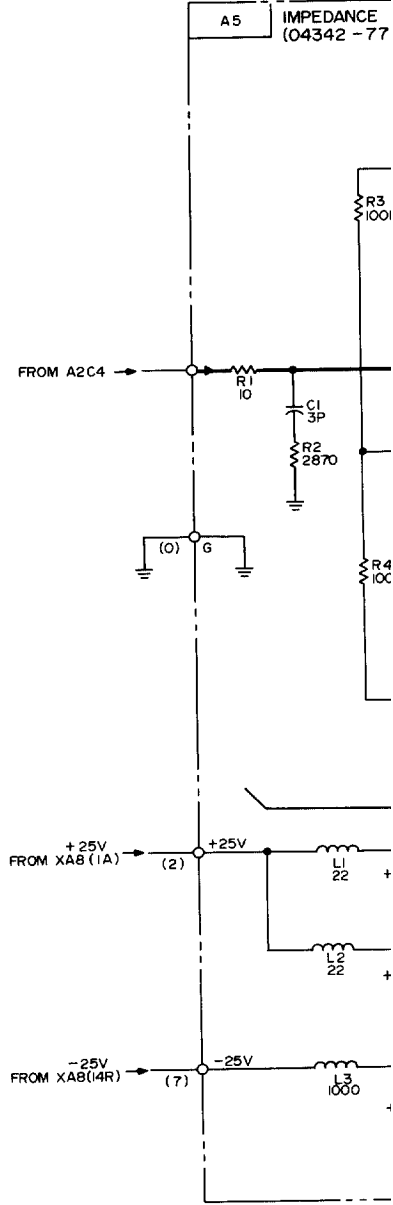

Figure A-1. Oscillator Ass'y (Option 001) A1
Frequency Multiplier & Over Limit Indicator Ass'y A10

A5 IMPEDANCE
(04342-77)





SEE INSIDE

Figure A-2
IMPEDANCE CONVERTER, RF AMPLIFIER &
DETECTOR ASS'Y (OPTION 001) A5

ONVERTER, RF AMPLIFIER & DETECTOR ASS'Y
5)

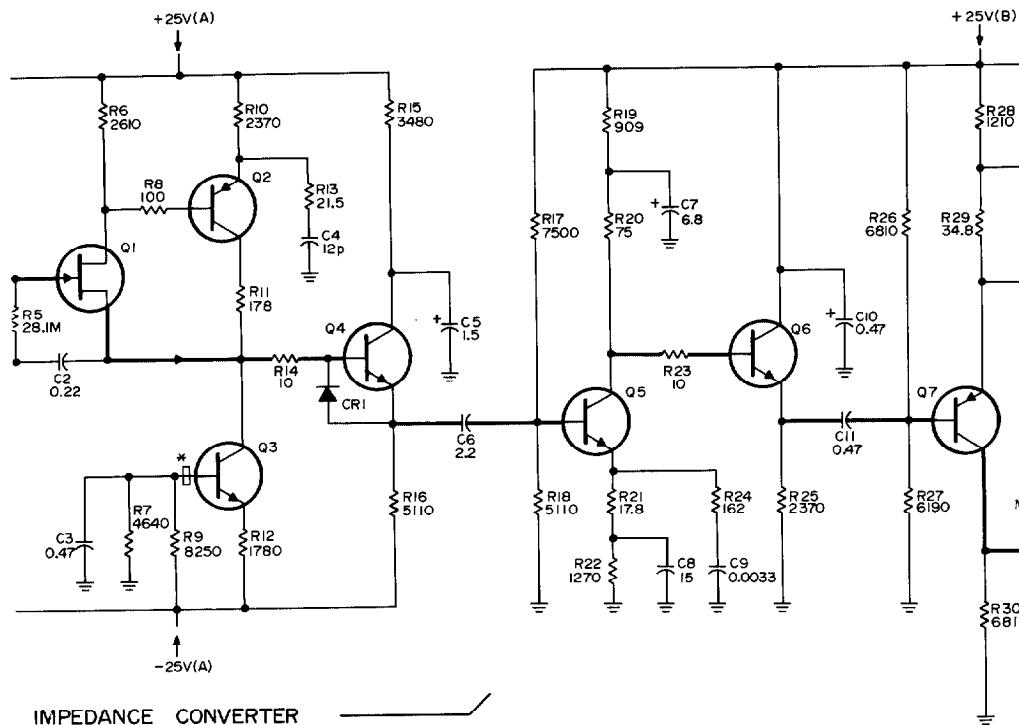

IMPEDANCE CONVERTER

→ +25V(A)

C21
0.47

→ +25V(B)

J22
0.47

→ -25V(A)

C23
1

RF

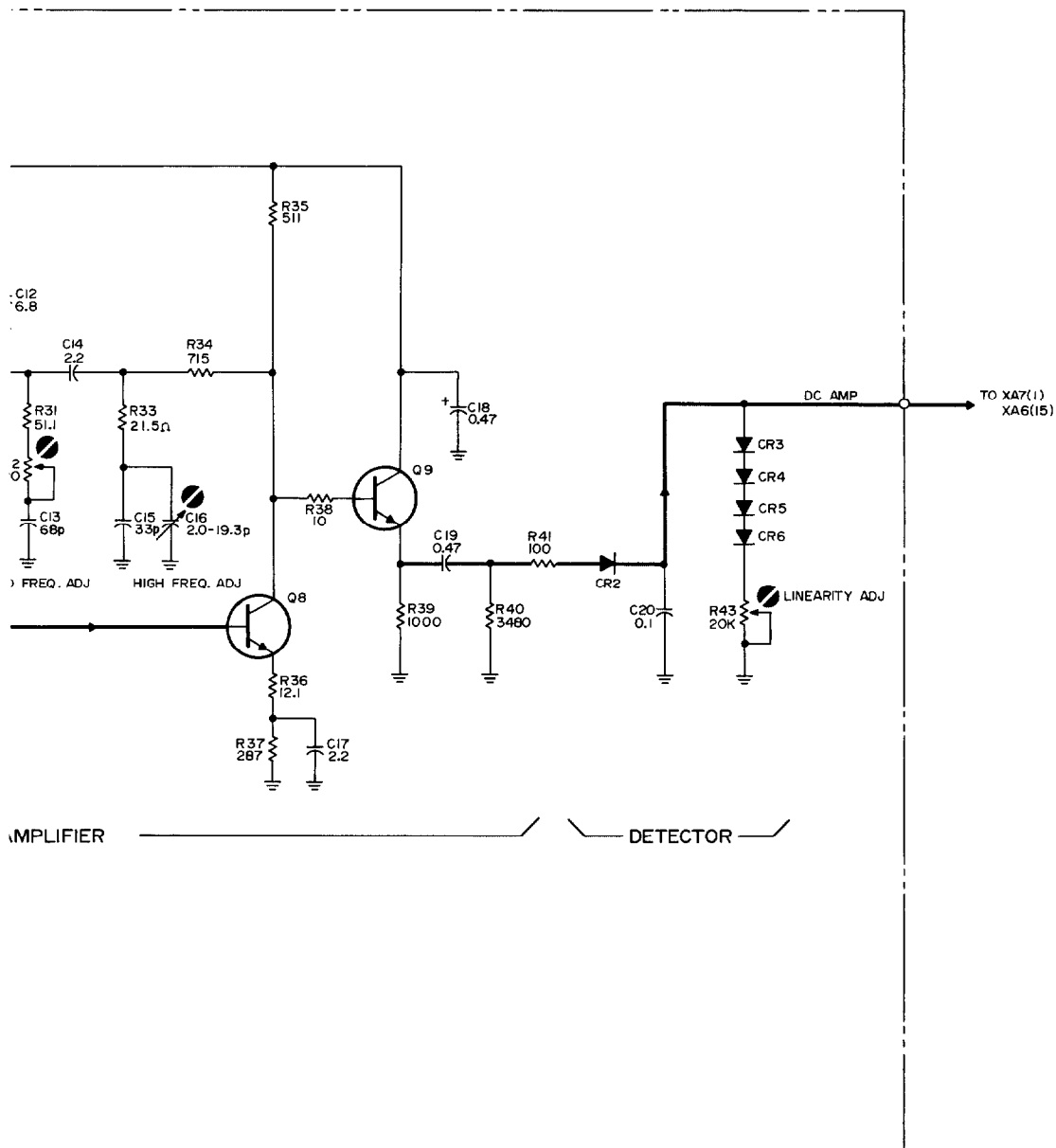

COPYRIGHT 1970 BY YOKOGAWA-HEWLETT-PACKARD, LTD.

REFERENCE DESIGNATIONS

NO PREFIX	A5 ASS'Y
	C1-C23 CR1-CR6 L1-L3 Q1-Q9 R1-R43

DELETED;

Figure A-2. Impedance Converter, RF Amplifier & Detector Ass'y (Option 001) A5