



Agilent Technologies

Innovating the HP Way

June 8, 2000

Dear Customer,

As of November 1, 1999, four of Hewlett-Packard's businesses, test and measurement, semiconductor products, health care solutions, and chemical analysis became a new company, Agilent Technologies. Now, many of your Hewlett-Packard products and services are in the care of Agilent Technologies.

At Agilent Technologies, we are working diligently to make this transition as smooth as possible for you. However, as a result of this transition, the products and related documentation contained in this shipment may be labeled with either the Hewlett-Packard name and logo, the Agilent Technologies name and logo, or a combination of both. Information in this package may refer to Hewlett-Packard (HP), but applies to your Agilent Technologies product. Hewlett-Packard and Agilent branded products with the same model number are interchangeable.

Whatever logo you see, the information, products, and services come from the same reliable source.

If you have questions about Agilent Technologies products and services, please visit our website at <http://www.agilent.com>.

Sincerely,

Rebranding Team

VOLUME 3 TABLE OF CONTENTS

Assembly	Schematic Service Sheet Number	Block Diagram	Theory/Trouble-Shooting Page Number	Parts List Page Number
A1 Keyboard and Display Assembly Keyboard Displays Annunciators	25	BD5	8F-167	6-5
	26	BD5	8F-173	6-5
	27	BD5	8F-177	6-5
A2 Audio Filters Assembly	12	BD4	8F-63	6-11
A3 Audio De-emphasis and Output Assembly	13	BD4	8F-69	6-15
A4 FM Demodulator Assembly Limiters Discriminator	10	BD3	8F-55	6-19
	11	BD3	8F-57	6-19
A5 Voltmeter Assembly Audio Detectors Voltmeter	14	BD4	8F-79	6-23
	15	BD4	8F-87	6-23
A6 AM Demodulator Assembly ALC Loop Control Circuits	8	BD3	8F-41	6-27
	9	BD3	8F-51	6-27
A10 Power Supply Regulators	31, 32	BD5	8F-213, 217	6-33
A11 Counter Assembly Time Base Counter	22	BD5	8F-143	6-37
	23	BD5	8F-147	6-37
A13 Controller Assembly	24	BD5	8F-157	6-41
A14 Remote Interface Assembly	28	BD5	8F-181	6-45
A15 RF Input	4	BD2	8F-17	6-47
A16 RF Buffer Amplifier Option 030 Only (2314A to 2636A)	5	BD2	8F-23	6-51
A17 Input Mixer Assembly 08901-60145 - (2314A to 2636A) 08902-60104 - (2642A and Above)	5	BD2	8F-23	6-53 6-57
A18 IF Amplifier Assembly	5	BD2	8F-23	6-61
A19 LO Divider Assembly	17	BD2	8F-101	6-63
A20 LO Control Assembly 08901-60185 - (2314A to 2622A) Analog Digital 08901-60262 - (2627A and Above) Analog Digital	20	BD2	8F-123	6-69
	21	BD2	8F-135	6-69
	20	BD2	8F-123	6-73
	21	BD2	8F-135	6-73
A21 Low Frequency VCXO Filter Assembly	19	BD2	8F-119	6-77

	Assembly	Schematic Service Sheet Number	Block Diagram	Theory/Trouble- Shooting Page Number	Parts List Page Number
A22	Low Frequency VCXO Assembly	19	BD2	8F-119	6-79
A23	Sampler Assembly	18	BD2	8F-107	6-81
A24	High Frequency VCO Assembly	18	BD2	8F-107	6-85
A25	Audio Motherboard Assembly	35	—	—	6-87
A26	Power Supply Motherboard Assembly	31-32	BD5	8F-213, 217	6-89
A27	Digital Motherboard Assembly	35	—	—	6-90
A28	RF Motherboard Assembly	35	—	—	6-91
A29	Series Regulator Heat Sink Assembly	31-32	BD5	8F-213, 217	6-92
A30	Line Module	31	BD5	8F-213	6-93
A31	Remote Interface Connector Assembly	28	BD5	8F-181	6-93
A32	Power Reference Oscillator Assembly	3	BD2	8F-15	6-94
A50	AM Calibrator Assembly	30	BD3	8F-205	6-95
A51	FM Calibrator Assembly	29	BD3	8F-197	6-99
A52	Audio Counter/Distortion Analyzer Assembly	16	BD4	8F-93	6-103
A53	Power Meter Assembly				
	Sensor Input Circuits	1	BD2	8F-1	6-107
	Control Circuits	2	BD2	8F-9	6-107
A54	IF Amplifier/Detector Assembly Option 030 Only (2314A to 2636A)	7	BD3	8F-37	6-111
A55	IF Channel Filter Option 030 Only (2314A to 2636A)	6	BD3	8F-33	6-113
A71	IF Amplifier/Detector Assembly Option 030 Only (2642A and Above)	34	BD3	8F-225	6-115
A72	IF Channel Filter Assembly Option 030 Only (2642A and Above)	33	BD3	8F-221	6-117

A53 Component Coordinates (1 of 2)

COMP	X,Y	COMP	X,Y	COMP	X,Y	COMP	X,Y	COMP	X,Y
C1	A,2	Q1	B,2	R26	B,2				
C2	A,3	Q5	B,2	R37	B,2				
C3	B,3	Q6	B,2	R38	B,2				
C4	B,2	Q8	B,2	R39	B,2				
C5	A,2	Q9	B,2	R40	B,1				
C7	A,1	Q10	B,2	R41	B,2				
C8	A,2	Q11	B,2	R42	B,2				
C9	A,2	Q12	B,2	R43	B,2				
C10	A,1			R44	B,2				
C11	A,2	R1	A,2	R45	B,2				
C12	A,1	R2	A,2	R46	B,2				
C13	A,2	R3	A,2	R47	B,2				
C14	A,2	R4	A,2	R48	B,2				
C15	A,2	R5	A,1	R49	B,2				
C16	A,2	R6	A,1	R50	B,2				
C17	A,2	R7	A,2	R51	B,2				
C18	A,2	R8	A,2	R52	B,2				
C19	A,2	R9	A,1						
C20	B,2	R10	A,1	U1	A,1				
C21	B,2	R11	A,2	U2	B,1				
C22	B,2	R2	A,2	U3	B,2				
C23	B,1	R13	A,2	U4	A,2				
C24	B,2	R14	A,2	U7	A,2				
C25	B,2	R15	A,2	U8	A,2				
C26	B,1	R16	A,2	VR1	A,2				
C27	B,1	R17	A,2	VR2	A,2				
C28	B,2	R18	A,2						
C29	B,2	R19	A,2						
C30	B,2	R20	A,2						
C31	B,2	R21	A,2						
C32	B,2	R22	A,2						
C33	B,2	R23	A,2						
C34	B,2	R24	A,2						
C36	A,2	R25	A,2						
C37	A,2	R26	A,2						
C39	A,2	R27	B,1						
		R28	B,2						
CR1	A,2	R29	B,2						
CR2	A,1	R30	B,1						
		R31	B,1						
J1	A,1	R32	B,1						
J2	A,1	R33	B,1						
		R34	B,2						
MP1	B,1	R35	B,2						

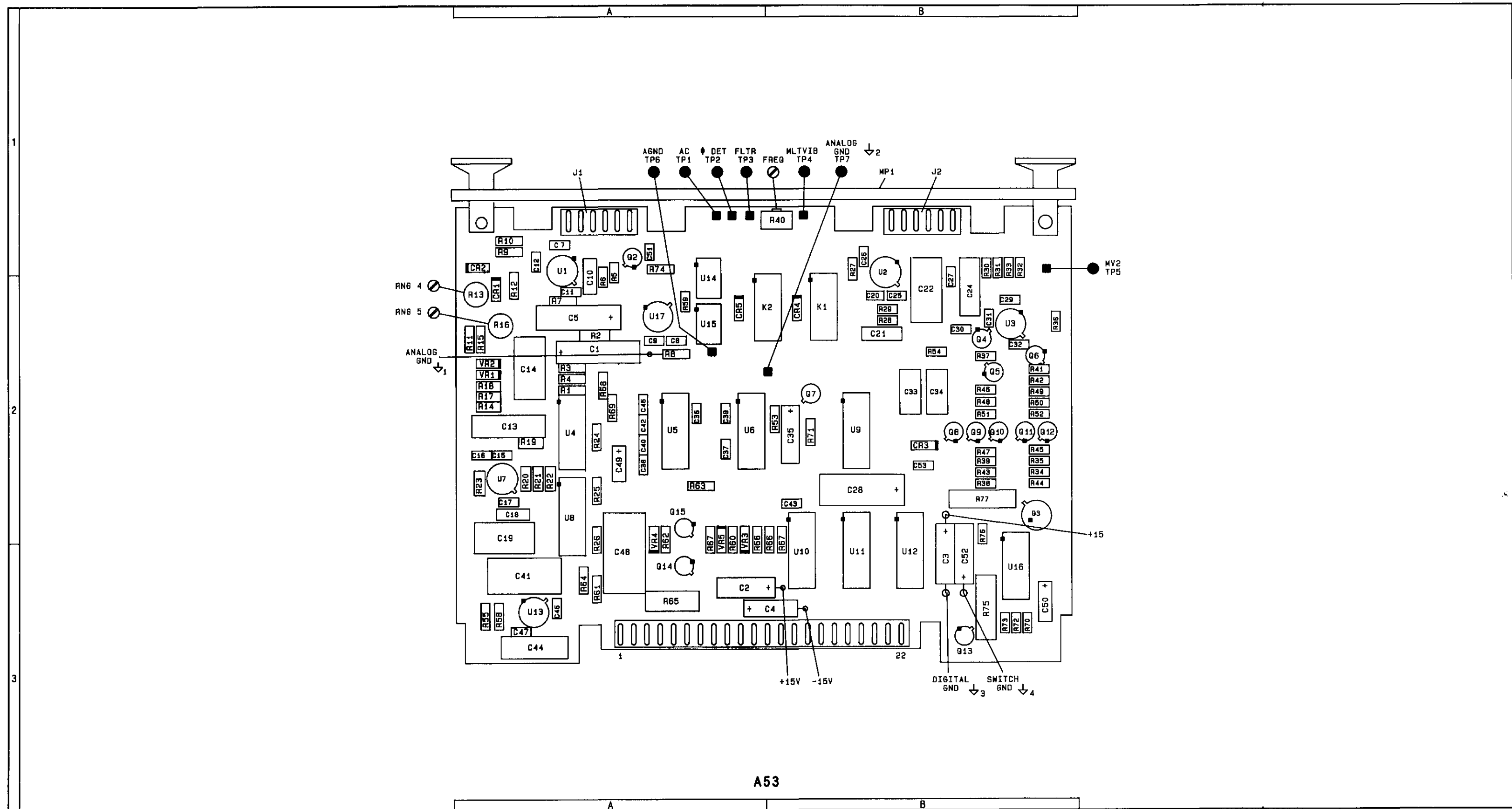

A53 Component Locator

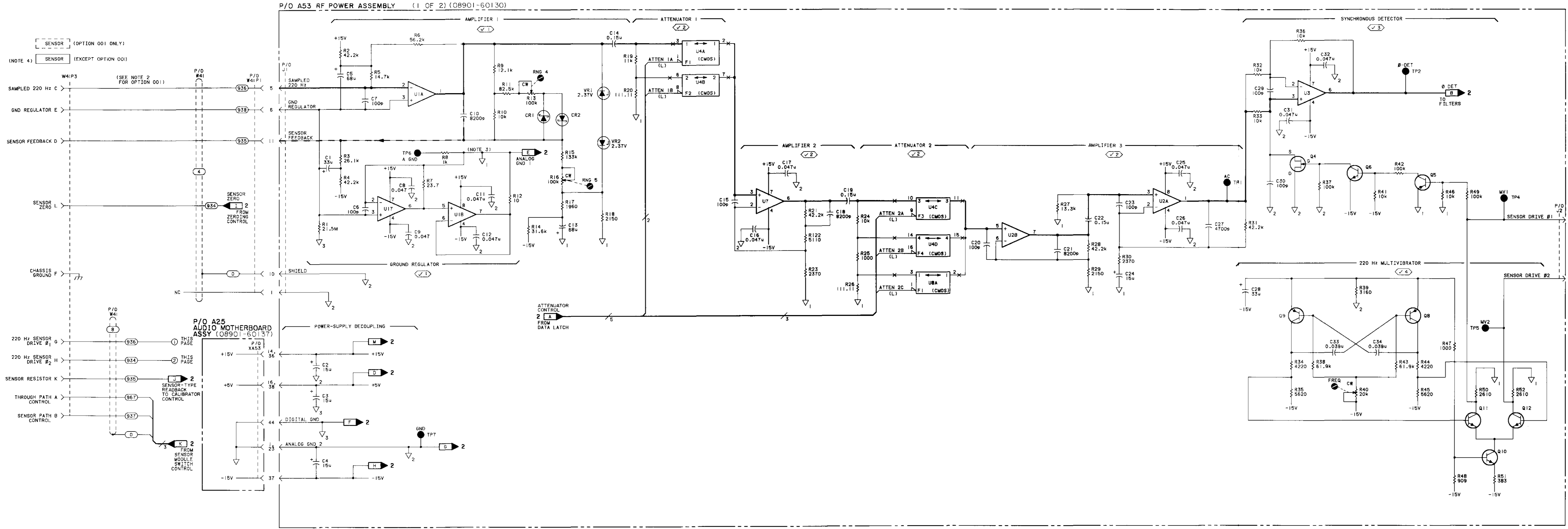

- NOTES
- SEE TABLE BA-4 SCHEMATIC DIAGRAM NOTES.
 - ALL REFERENCE TO W41 SHOULD BE CHANGED TO W42 WHEN OPTION DO1 IS USED.
 - ANALOG GND 1 IS A COMMON GROUND FOR A53 CREATED BY THE A53 GROUND REGULATOR CIRCUIT.
 - FRONT PANEL VIEW OF SENSOR CONNECTOR W41P3:

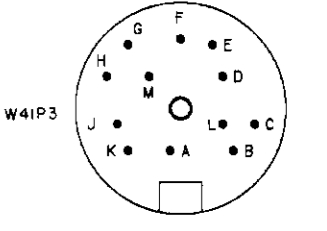

DIGITAL INTEGRATED CIRCUIT VOLTAGE AND GROUND CONNECTIONS

REFERENCE DESIGNATIONS	PART NUMBERS
U4, B	+15V - 13
	-15V - 4
	△ - 5

A53 Component Coordinates (2 of 2)

COMP	X,Y	COMP	X,Y	COMP	X,Y	COMP	X,Y	COMP	X,Y
C35	B,2	R64	A,3						
C38	A,2	R65	A,3						
C40	A,2	R66	A,2						
C41	A,3	R67	A,2						
C42	A,2	R68	A,2						
C43	B,2	R69	A,2						
C44	A,3	R70	B,3						
C45	A,2	R71	B,2						
C46	A,3	R72	B,3						
C47	A,3	R73	B,3						
C48	A,3	R74	A,1						
C49	A,2	R75	B,3						
C50	B,3	R76	B,2						
C51	A,1	R77	B,2						
C52	B,3								
C53	B,2	TP3	A,2						
CR3	B,2	U5	A,2						
CR4	B,2	U6	A,2						
CR5	A,2	U9	B,2						
		U10	B,3						
J1	A,1	U11	B,3						
J2	A,1	U12	B,3						
		U13	A,3						
K1	B,2	U14	A,1						
K2	B,2	U15	A,2						
		U16	B,3						
Q2	A,1	U17	A,2						
Q3	B,2								
Q7	B,2	VR3	A,2						
Q13	B,3	VR4	A,2						
Q14	A,3	VR5	A,2						
Q15	A,2								
R53	B,2								
R54	B,2								
R55	A,3								
R56	B,2								
R57	B,2								
R58	A,3								
R59	A,2								
R60	A,2								
R61	A,3								
R62	A,2								
R63	A,2								

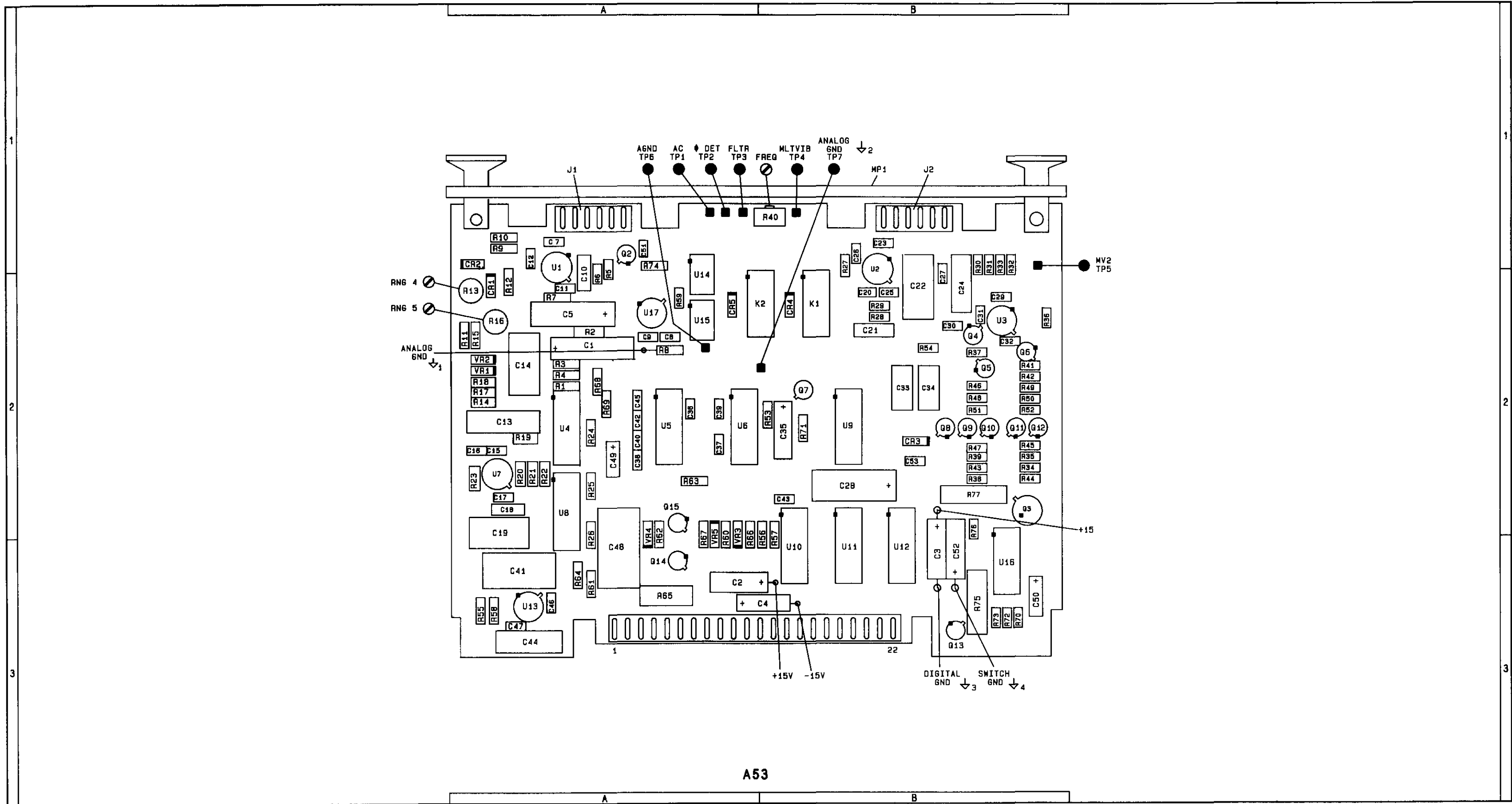

A53

Component Locator

A53 POWER METER (1 OF 2)
SENSOR INPUT CIRCUITS

SS1

SEE REVERSE SIDE

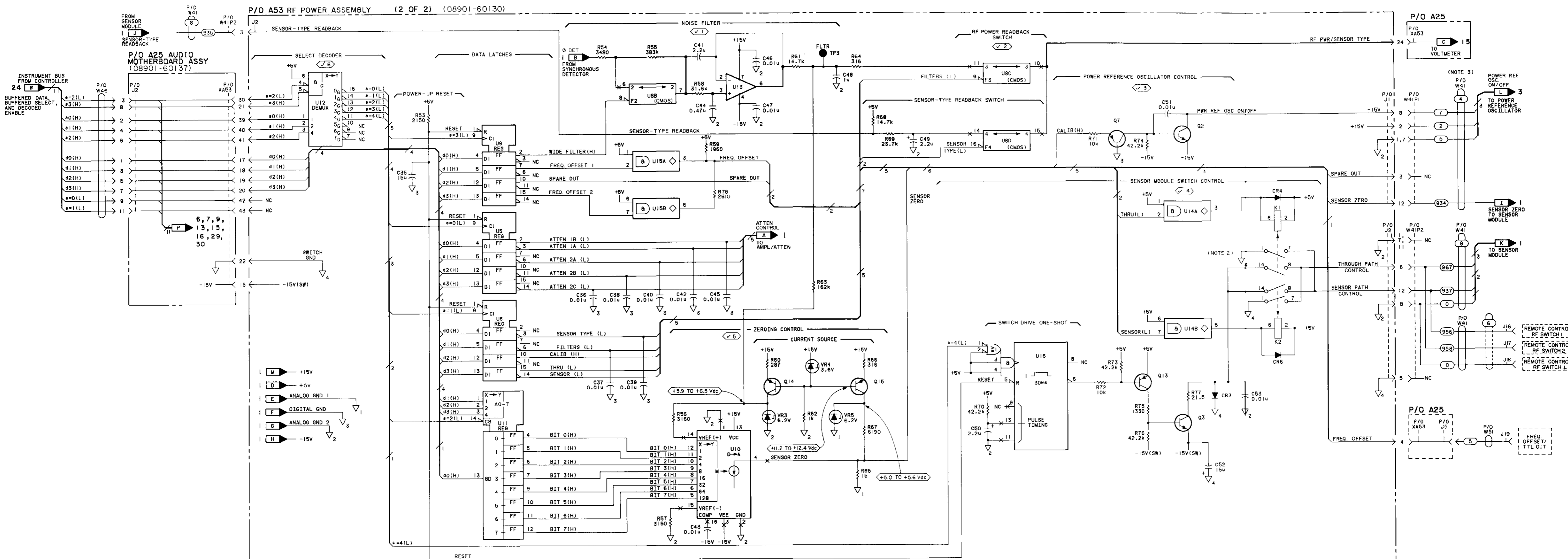

- NOTES
1. SEE TABLE 8A-# SCHEMATIC DIAGRAM NOTES.
 2. THE DIAGRAM BELOW SHOWS THE INTERNAL CIRCUITRY OF A53K1,2.
 3. FOR OPTION 001, W42 REPLACES W41.

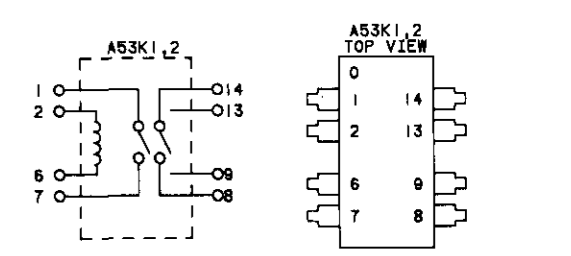

DIGITAL INTEGRATED CIRCUIT VOLTAGE AND GROUND CONNECTIONS

REFERENCE DESIGNATIONS	PIN NUMBERS
U5, 6, 9	+5V -15, 16 ∇2 - 8
U8	+15V -13 -15V -4 ∇2 - 5
U11, 12	+5V -16 ∇2 - 8
U14, 15	+5V -8 ∇2 - 4
U16	+5V -14 ∇2 - 7

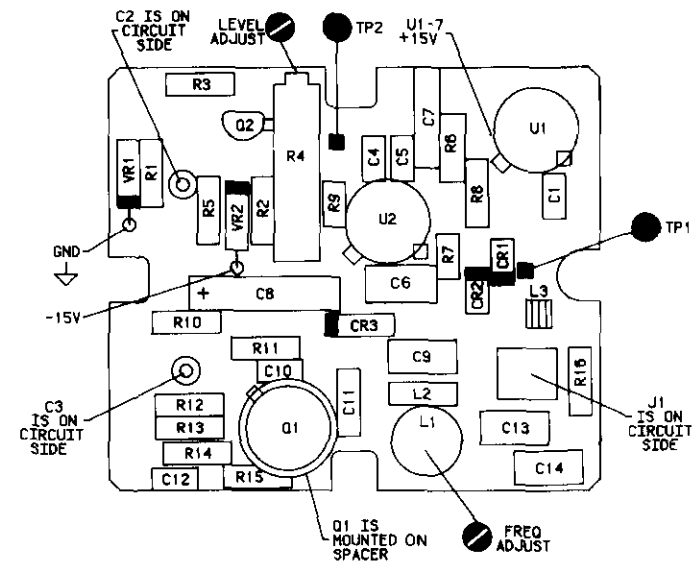
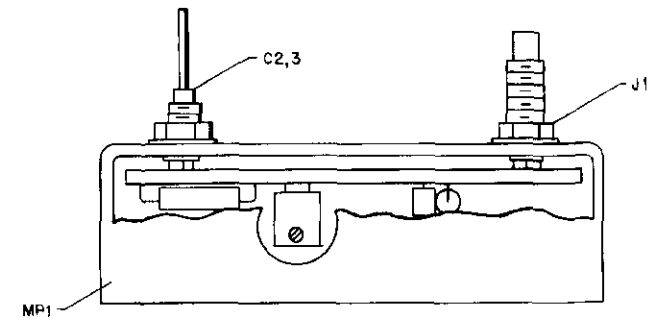

A32

Component Locator

A53 POWER METER (2 OF 2)
CONTROL CIRCUITS

SS2

SEE REVERSE SIDE

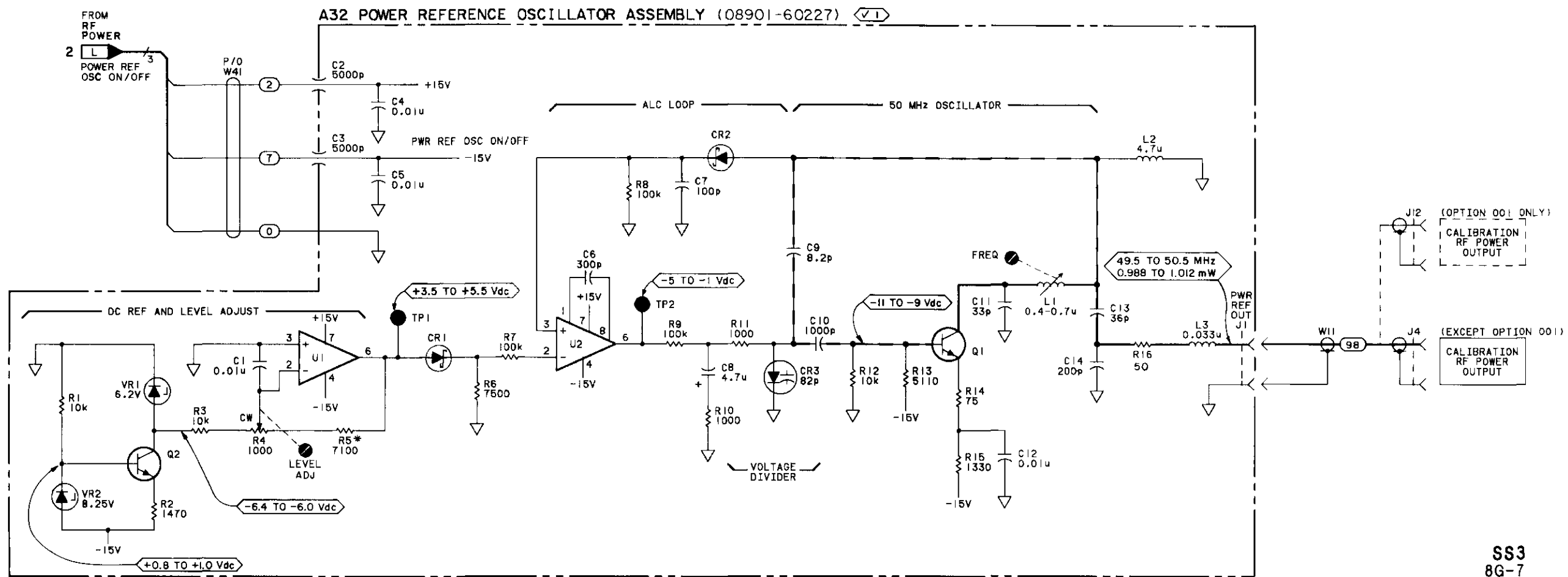

NOTES
 1. SEE TABLE 8A-4 FOR SCHEMATIC DIAGRAM NOTES.

SS3
 8G-7

A15 Component Coordinates

COMP	X,Y	COMP	X,Y	COMP	X,Y	COMP	X,Y	COMP	X,Y
C1	A,3	L2	B,1	R28	A,2				
C2	A,1	L3	B,1	R29	B,1				
C3	A,3	L4	B,1	R30	B,2				
C4	B,3			R31	A,3				
C5	A,3	MP1	B,1	R32	B,2				
C6	A,1	MP2	A,2	R33	A,2				
C7	B,3	MP3	B,2	R34	A,2				
C8	B,3	MP4	A,2	R35	B,2				
C9	A,3	MP5	A,2	R36	B,2				
C10	B,1	MP6	A,2	R37	B,3				
C11	A,2			R38	A,3				
C12	B,1	Q1	A,2	R39	A,2				
C13	A,2	Q2	B,2	R40	B,1				
C14	B,1	Q6	A,2	R41	A,2				
C15	B,3	Q7	B,2	R42	A,1				
C16	B,1	Q8	B,2	R43	B,2				
C17	B,2	Q9	A,2	R44	B,2				
C18	A,3	Q10	A,2	R45	B,1				
C19	B,2	Q11	B,3	R46	A,2				
C20	A,3			R47	A,2				
C21	B,2	R1	A,3	R48	A,3				
C22	A,2	R2	A,3	R49	A,2				
C23	B,1	R3	A,3	R50	A,3				
C24	A,3	R4	A,3	R51	B,2				
C25	A,2	R5	A,2	R52	B,2				
C26	B,2	R7	A,3	R53	A,3				
C27	B,3	R8	A,2	R54	B,2				
C28	A,1	R9	A,2	R55	B,2				
		R10	A,2	R56	B,2				
CR1	A,2	R11	B,3	R57	B,3				
CR3	A,2	R12	B,2	R58	B,3				
CR4	A,2	R13	B,2	R59	A,2				
CR7	A,2	R14	B,1	R60	A,2				
CR8	A,2	R15	A,1	R61	A,3				
		R16	B,1	R62	A,2				
J1	A,1	R17	A,2						
J2	B,1	R19	A,1	TP1	A,1				
		R20	A,1						
K1	A,1	R21	A,2	U1	A,2				
K2	B,2	R22	A,3	U2	A,3				
K3	A,2	R23	B,2	U3	B,3				
K4	B,2	R24	A,2						
K5	B,1	R25	B,2						
		R26	A,2						
L1	B,1	R27	B,2						

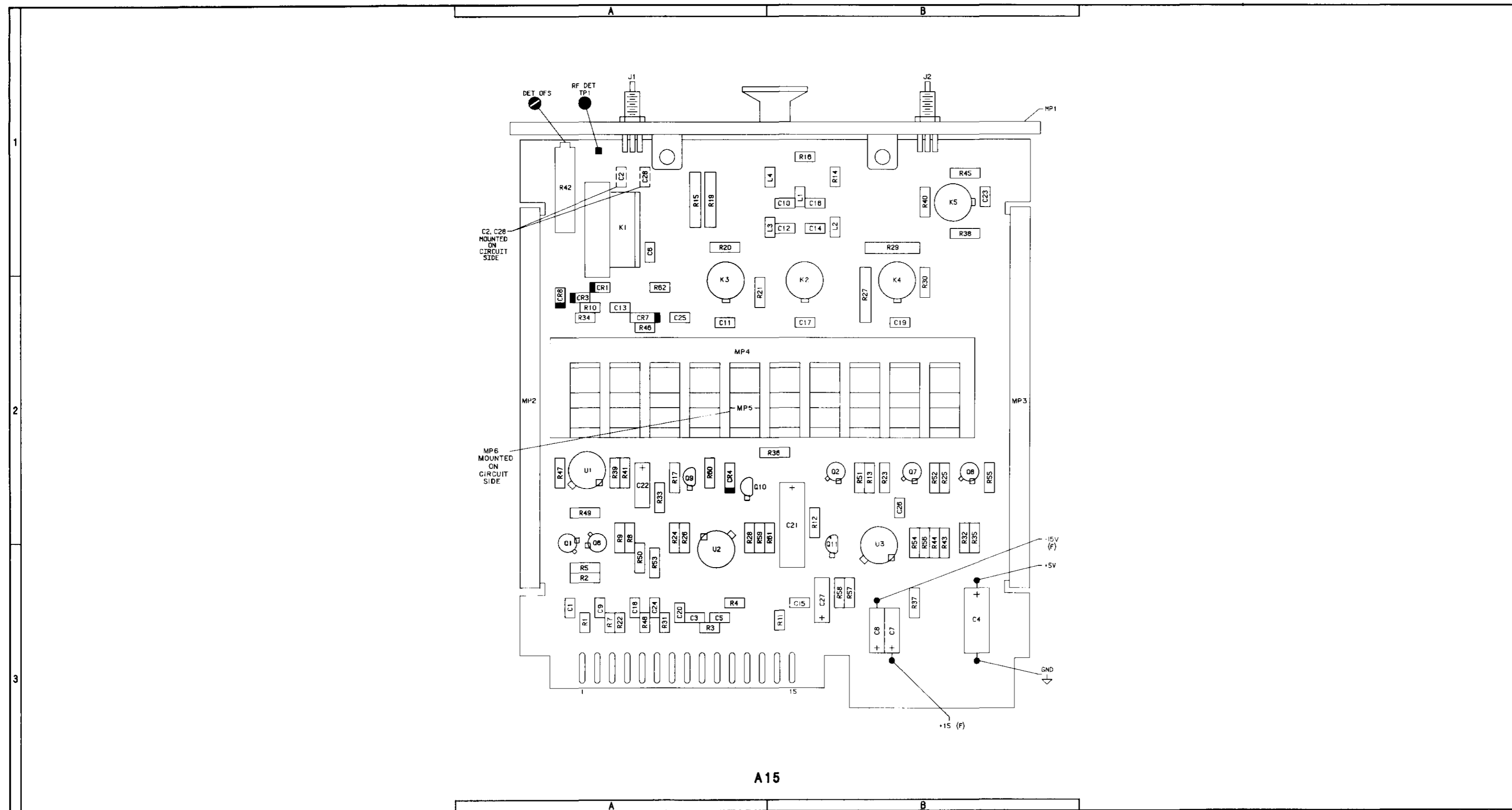

Component Locator

SEE REVERSE SIDE **SS3** A32 POWER REFERENCE OSCILLATOR

P/O A28 RF MOTHERBOARD ASSY (08901-60229)

A15 RF INPUT ASSEMBLY (08901-60183)

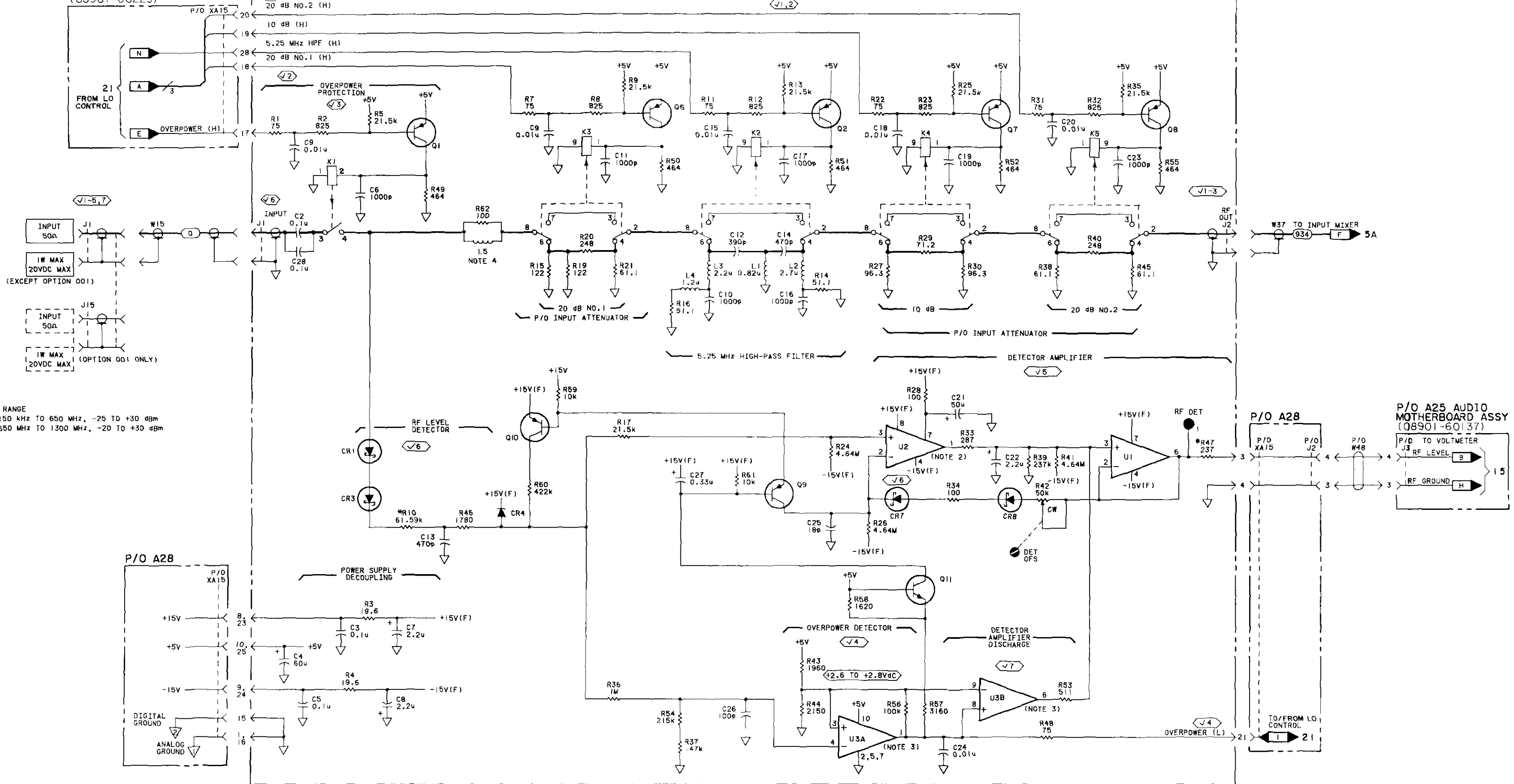

NOTE:
INPUT RANGE
150 kHz TO 650 MHz, -25 TO +30 dBm
650 MHz TO 1300 MHz, -20 TO +30 dBm

NOTES

- SEE TABLE BA-4 FOR SCHEMATIC DIAGRAM NOTES.
- THE DIAGRAM BELOW SHOWS THE OUTPUT STAGE OF COMPARATOR A15U2 IN DETAIL.
- OPEN COLLECTOR OUTPUT.
- PC TRACE INDUCTOR

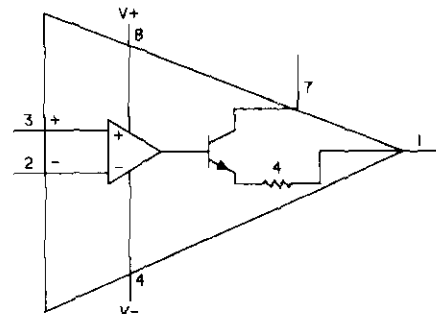

A15K2-5 BOTTOM VIEW

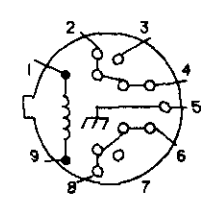

CIRCUIT BOARD TOP VIEW

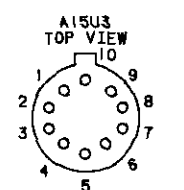
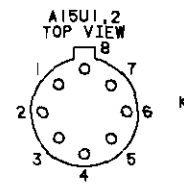
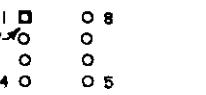

CIRCUIT BOARD TOP VIEW

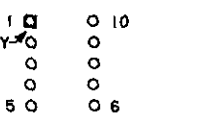

P/O A25 AUDIO MOTHERBOARD ASSY (08901-60137)

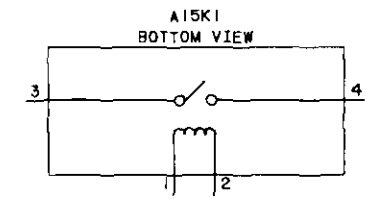

A15K1 BOTTOM VIEW

A17 & A18 Component Coordinates (2642A AND ABOVE)

A17		COMP	X,Y	COMP	X,Y	A18		COMP	X,Y
COMP	X,Y					COMP	X,Y		
		DS1	A,1	R12	B,2			R1	D,3
C1	B,1	J1	A,1	R13	A,2	C1	C,3	R2	D,3
C2	A,3	J2	B,1	R14	B,3	C2	C,3	R3	D,2
C3	B,2	J3	B,1	R15	B,3	C3	D,2	R4	D,2
C4	A,3	J4	A,1	R16	B,2	C4	D,1	R5	D,2
C5	A,3			R17	B,2	C5	D,3	R6	D,2
C6	B,2	L1	A,3	R18	B,2	C6	D,2	R7	D,2
C7	B,2	L2	A,3	R19	B,2	C7	C,1	R8	D,1
C8	B,3	L3	B,2	R20	B,2	C8	D,2	R9	D,1
C9	B,2	L4	B,2	R21	B,2	C9	C,1	R10	C,2
C10	B,2	L5	B,1	R22	B,2	C10	C,1	R11	C,1
C11	A,2	L6	A,2	R23	B,2	C11	C,1	R12	C,2
C12	B,3	L7	A,2	R24	B,2	C12	C,3	R13	D,2
C13	A,2	L8	A,1	R25	B,3	C13	D,2	R14	D,1
C14	B,2	L9	A,1	R26	A,2	C14	C,2	R15	D,2
C15	A,2	L10	A,2	R27	B,2	C15	C,2	R16	D,2
C16	A,3	L11	A,1	R28	B,3	C16	C,2	R17	D,1
C17	A,2	L12	A,2	R29	A,2	C17	C,2	R18	D,1
C18	A,2	L14	A,2	R30	A,2	C18	C,2	R19	D,1
C19	A,2			R31	A,2	C19	C,2	R20	D,1
C20	A,2	MP1	A,1	R32	A,2	C20	C,3	R21	D,2
C21	A,2	MP2	A,2	R33	A,2	C21	D,2	R22	D,2
C22	A,2	MP3	A,2	R34	A,2			R23	C,1
C23	A,2			R35	A,2	CR1	D,2	R24	C,2
C24	A,2	Q1	A,2	R36	A,2	CR2	B,2	R25	C,2
C25	A,2	Q2	A,2	R37	A,2	CR3	D,2	R26	C,2
C26	A,2	Q3	A,2	R38	A,2	CR4	D,2	R27	C,2
C27	B,2	Q4	B,2	R39	A,2	CR5	D,2	R28	C,2
C28	A,2	Q5	B,2	R40	A,2	CR6	D,2	R29	C,2
C29	B,2	Q6	B,2	R41	A,2	CR7	D,2	R30	C,2
C30	A,2	Q7	B,2	R42	A,2			R31	C,2
C31	A,2	Q8	A,2	R43	B,3	J1	C,1	R32	C,2
C32	A,2	Q9	A,2	R44	A,2	J2	D,1	R33	D,2
C33	A,3	Q10	A,2	R45	B,3				
C34	B,3	Q11	A,2	R46	A,3	L1	C,2		
C35	A,1	Q12	B,3	R47	A,2	L2	C,2		
C36	A,2	Q13	B,3	R48	A,2				
				R49	A,3	MP1	D,1		
				R50	B,3				
CR1	B,2	R1	B,2			Q1	D,1		
CR2	B,2	R2	B,2			Q2	C,2		
CR3	B,2	R3	A,3	T1	B,2	Q3	C,2		
CR3	A,2	R4	A,3			Q4	C,2		
CR4	A,2	R5	A,3	U1	B,2	Q5	D,2		
CR5	A,2	R6	B,2			Q6	D,2		
CR6	A,2	R7	B,1			Q7	D,2		
CR7	A,2	R8	B,2						
CR8	A,3	R9	B,2						
CR9	A,3	R10	B,2						

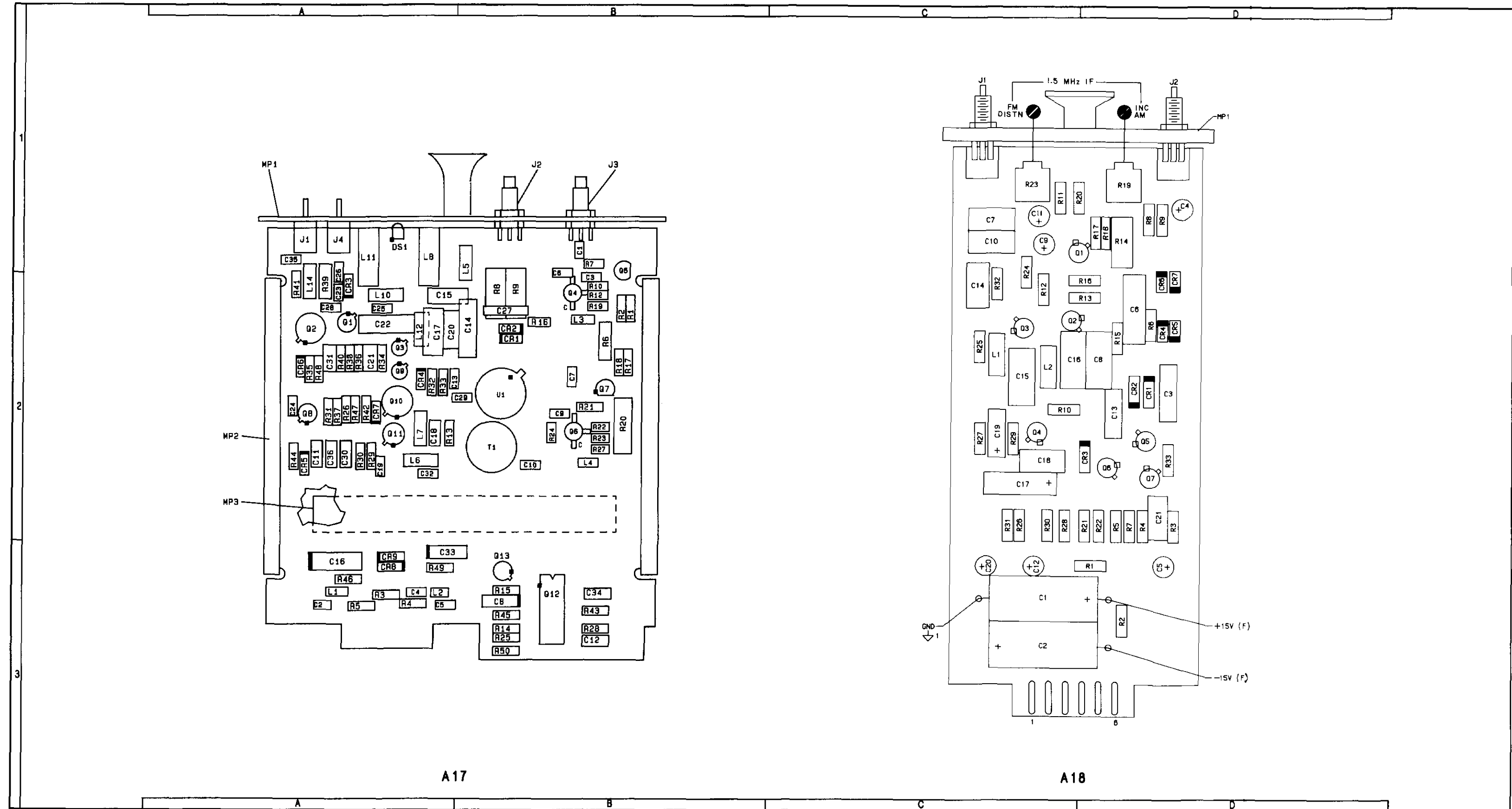

Component Locators

A15 RF INPUT

SS4

SEE REVERSE SIDE

CHANGES

All serial prefixes

On the schematic:

- SS5 - Add to the front label, A16, and change the serial prefix to 2314A to 2636A.

2333A to 2636A

In the A17 component coordinates:

- A17L14 - Add L14 with coordinates A,1.
- A17C28 - Add C28 with coordinates A,2.

On the A17 component locator:

- A17L14 - In grid location A,1 add L14 between L12 and C20.
- A17C28 - In grid location A,2 add C28 directly to the right of R25.

On the A17 schematic:

- C28, L6, L14 - Delete L6 and replace it with C28, L14, and new L6 as shown in the figure P/O A17 Input Mixer Assembly (2333A to 2636A) on page 8G-10.3

2414A to 2636A

On the A17 component locator:

- A17MP5, MP6 - Delete all references to MP5 and MP6.

On the A17 schematic:

- SHIELD - In the lower, left portion of the A17 schematic, delete the title "SHIELD" and the dashed line that represents the shield.

2443A to 2636A

On the A18 schematic:

- A18E1 - Add a ferrite bead, E1, to the base of Q7.

2642A and above

SS5:

- Use SS5 (2642A) on page 8G-12 and 8G-13.

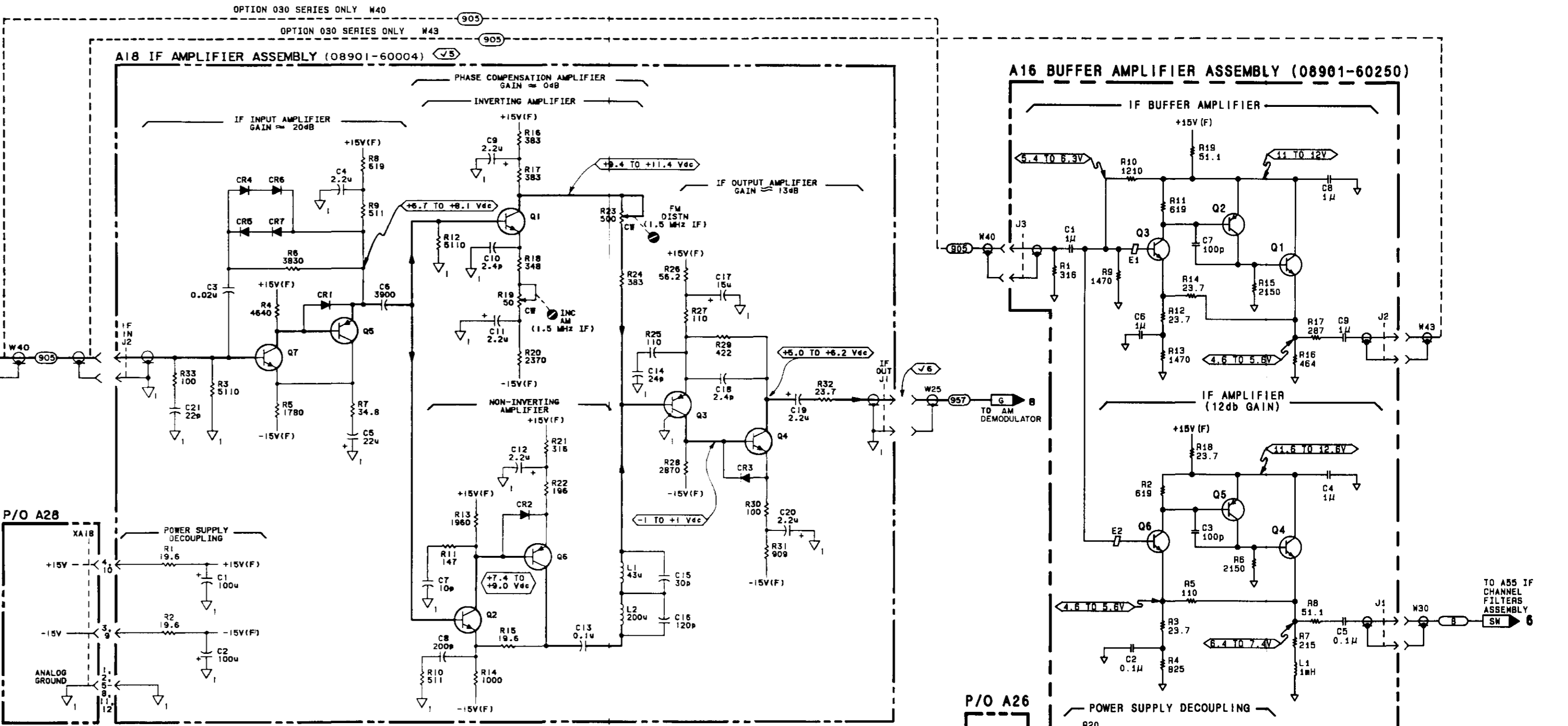
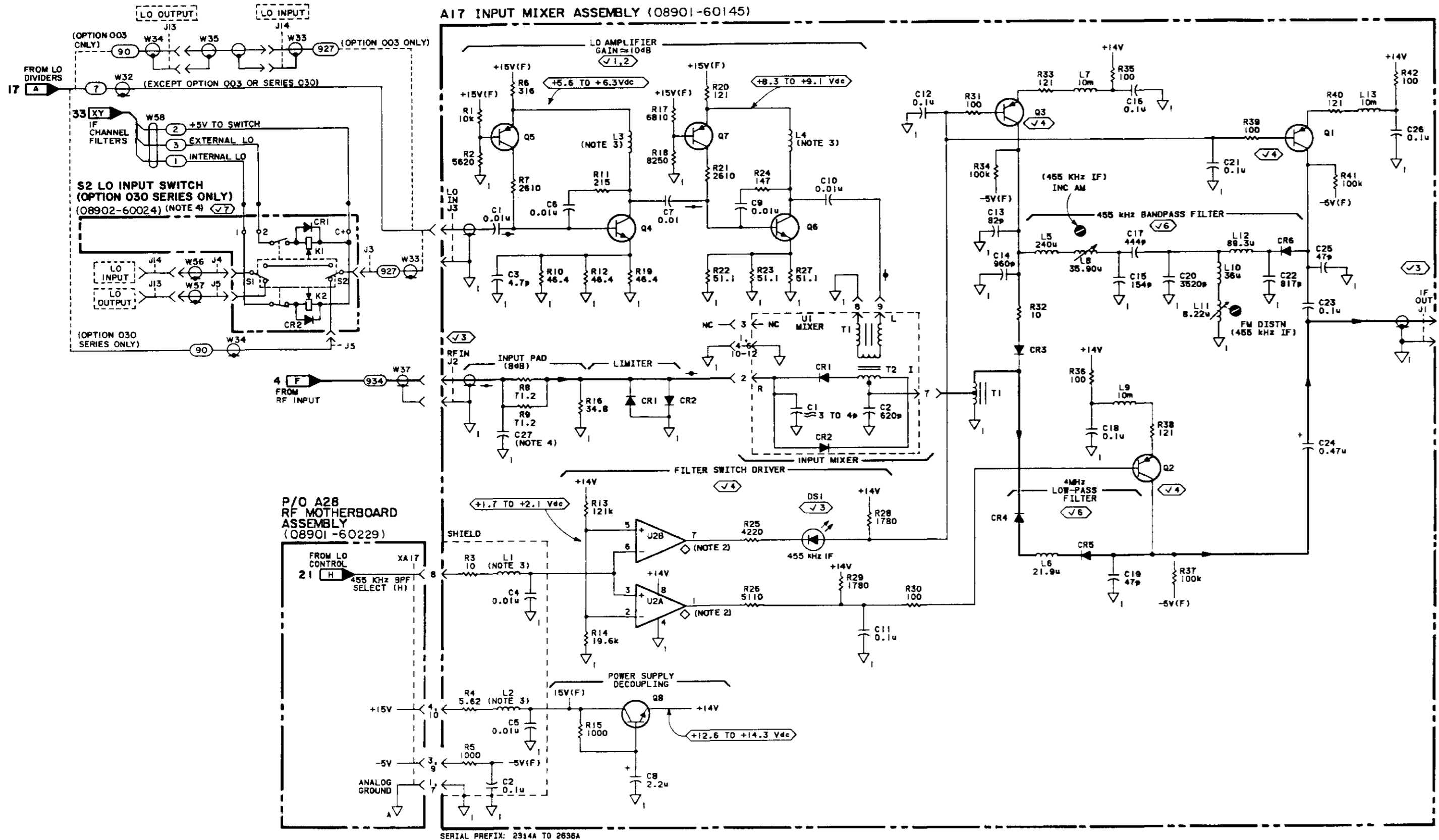

NOTES:

- SEE TABLE BA-4 SCHEMATIC DIAGRAM NOTES.
- OPEN COLLECTOR OUTPUT.
- INDUCTANCE IS APPROXIMATELY 4.5uH AT 1MHz.
- A17C27 IS A METAL STRAP OVER R8 AND R9.
- OPTION 003 IS NOT AVAILABLE IN CONJUNCTION WITH OPTION 030 SERIES.
- RELAYS IN S2 ARE LATCHING TYPE. A MOMENTARY TTL LOW INPUT WILL ACTUATE THE INDICATED SEGMENT, AND THEN DEACTIVATE THE SWITCHING SOLENOID.

7. SWITCH CONNECTION LOCATOR

NC	J1	S2	1	1
INTERNAL LO	J2			
MIXER	J3	C+	2	
EXTERNAL LO IN	J4			
EXTERNAL LO OUT	J5	2	3	

A17U1 TOP VIEW

A17 Q4,6 TOP VIEW

A17 & A18 Component Coordinates (2314A TO 2636A)

A17		COMP	X,Y	COMP	X,Y	A18		COMP	X,Y
COMP	X,Y	L7	A,2	R20	B,2	COMP	X,Y	R1	D,3
C1	B,1	L8	A,1	R21	B,2	C1	C,3	R2	D,3
C2	A,3	L9	A,2	R22	B,2	C2	C,3	R3	D,2
C3	B,1	L10	A,1	R23	B,2	C3	D,2	R4	D,2
C4	A,3	L11	A,1	R24	B,2	C4	D,1	R5	D,2
C5	A,3	L12	A,1	R25	A,2	C5	D,3	R6	D,2
C6	B,1	L13	A,2	R26	A,2	C6	D,2	R7	D,2
C7	B,2			R27	B,2	C7	C,1	R8	D,1
C8	B,3	MP1	B,1	R28	A,2	C8	D,2	R9	D,1
C9	B,2	MP1	B,1	R29	A,2	C9	C,1	R10	C,2
C10	B,2	MP2	A,2	R30	A,2	C10	C,1	R11	C,1
C11	A,2	MP3	B,1	R31	A,2	C11	C,1	R12	C,2
C12	A,2	MP3	B,1	R32	A,2	C12	C,3	R13	D,2
C13	A,2	MP4	B,2	R33	A,2	C13	D,2	R14	D,1
C14	B,1	MP4	B,2	R34	A,2	C14	C,2	R15	D,2
C15	A,1	MP5	A,3	R35	A,2	C15	C,2	R16	D,2
C16	A,2	MP5	A,3	R36	A,2	C16	C,2	R17	D,1
C17	A,2	MP6	A,3	R37	A,1	C17	C,2	R18	D,1
C18	A,2	MP6	A,3	R38	A,2	C18	C,2	R19	D,1
C19	A,1			R39	A,2	C19	C,2	R20	D,1
C20	A,1	Q1	A,2	R40	A,2	C20	C,3	R21	D,2
C21	A,2	Q2	A,2	R41	A,1	C21	D,2	R22	D,2
C22	A,2	Q3	A,2	R42	A,2			R23	C,1
C23	A,1	Q4	B,1			CR1	D,2	R24	C,2
C24	A,1	Q5	B,1	T1	B,2	CR2	B,2	R25	C,2
C25	A,1	Q6	B,2			CR3	D,2	R26	C,2
C26	A,2	Q7	B,2	U1	B,2	CR4	D,2	R27	C,2
C27	B,1	Q8	B,3	U2	B,3	CR5	D,2	R28	C,2
						CR6	D,2	R29	C,2
CR1	B,2	R1	B,1			CR7	D,2	R30	C,2
CR2	B,1	R2	B,1					R31	C,2
CR3	A,2	R3	A,3			J1	C,1	R32	C,2
CR4	A,2	R4	A,3			J2	D,1	R33	D,2
CR5	A,2	R5	A,3						
CR6	A,1	R6	B,2			L1	C,2		
		R7	B,1			L2	C,2		
		R8	B,1						
DS1	A,1	R9	B,1			MP1	D,1		
		R10	B,1						
J1	A,1	R11	B,1			Q1	D,1		
J2	B,1	R12	B,1			Q2	C,2		
J3	B,1	R13	B,3			Q3	C,2		
		R14	A,3			Q4	C,2		
L1	A,3	R15	B,3			Q5	D,2		
L2	A,3	R16	B,1			Q6	D,2		
L3	B,1	R16	B,2			Q7	D,2		
L4	B,2	R17	B,2						
L5	B,1	R19	B,1						
L6	A,2								

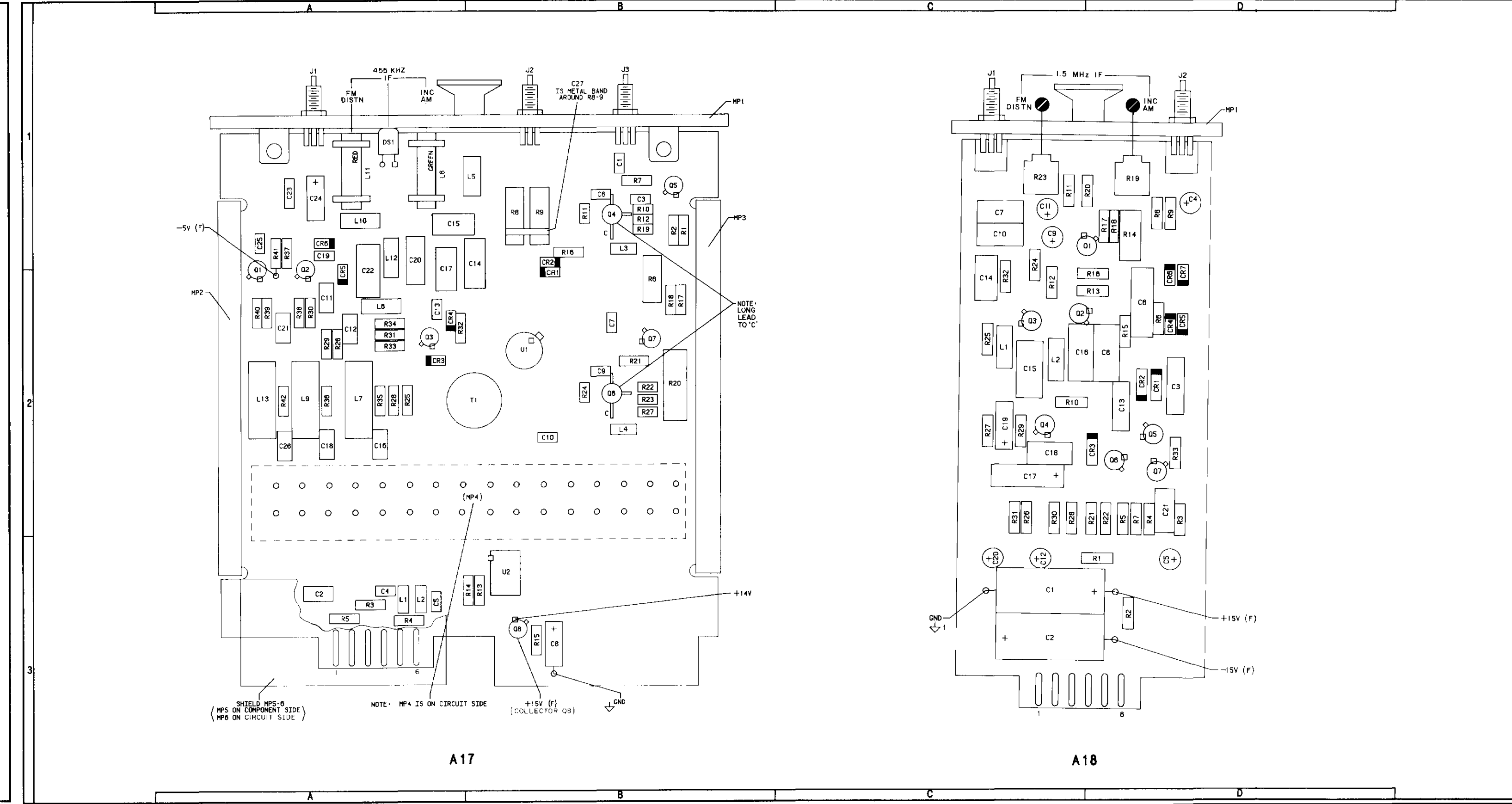
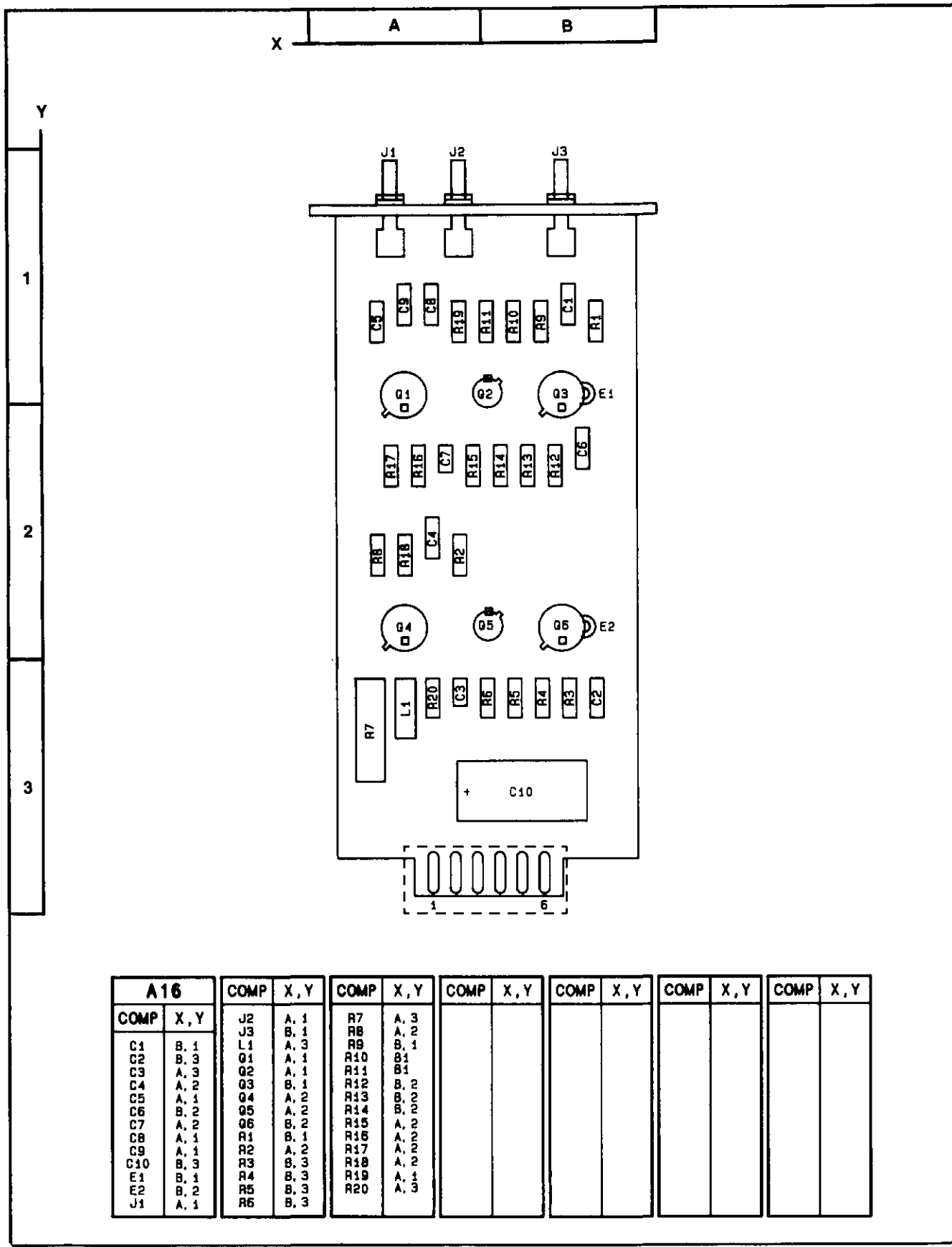

Component Locators

A17 INPUT MIXER
A18 IF AMPLIFIER

SS5

SEE REVERSE SIDE SERIAL PREFIX: 2642A AND ABOVE

CHANGES

All serial prefixes

On the schematic:

- SS5 - On the front label delete A16 and change the serial prefix to 2642A and above.

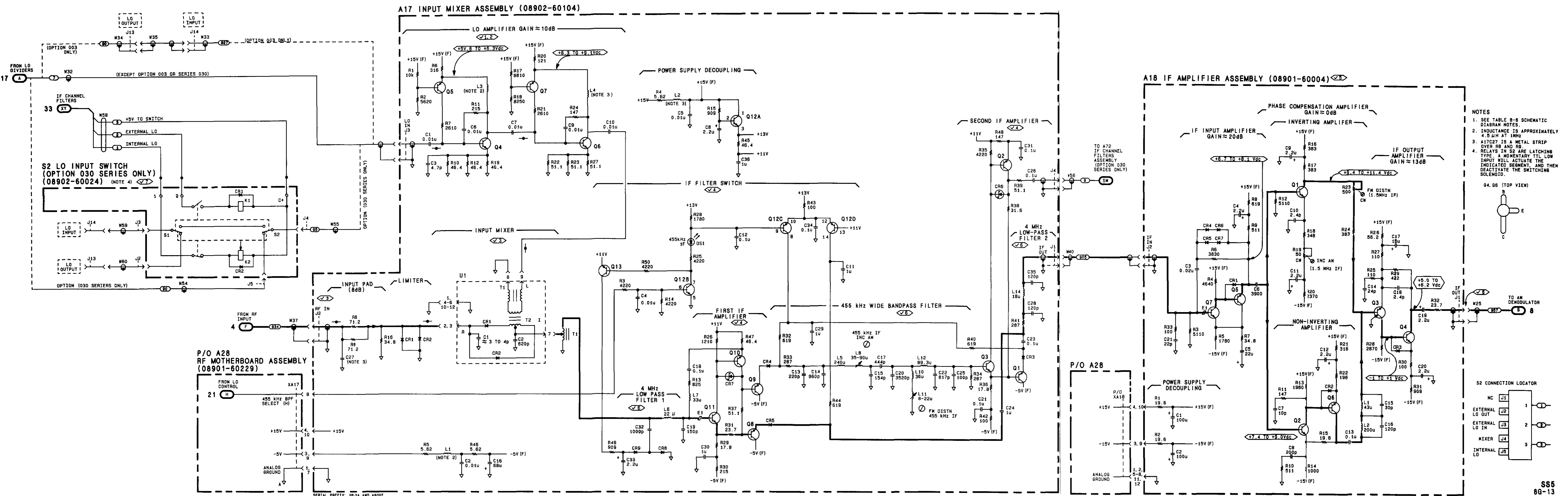

- NOTES**
- SEE TABLE B-8 SCHEMATIC DIAGRAM NOTES.
 - INDUCTANCE IS APPROXIMATELY 4.5 μH AT 1MHz.
 - A17C27 IS A METAL STRIP OVER RB AND R9.
 - RELAYS IN S2 ARE LATCHING TYPE. A MOMENTARY TTL LOW INPUT WILL ACTIVATE THE INDICATED SEGMENT, AND THEN DEACTIVATE THE SWITCHING SOLENOID.

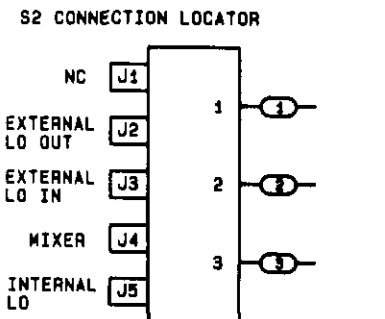
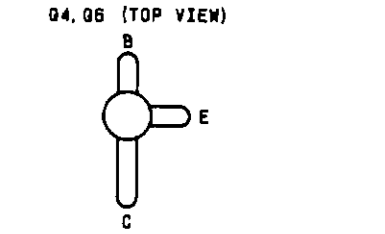

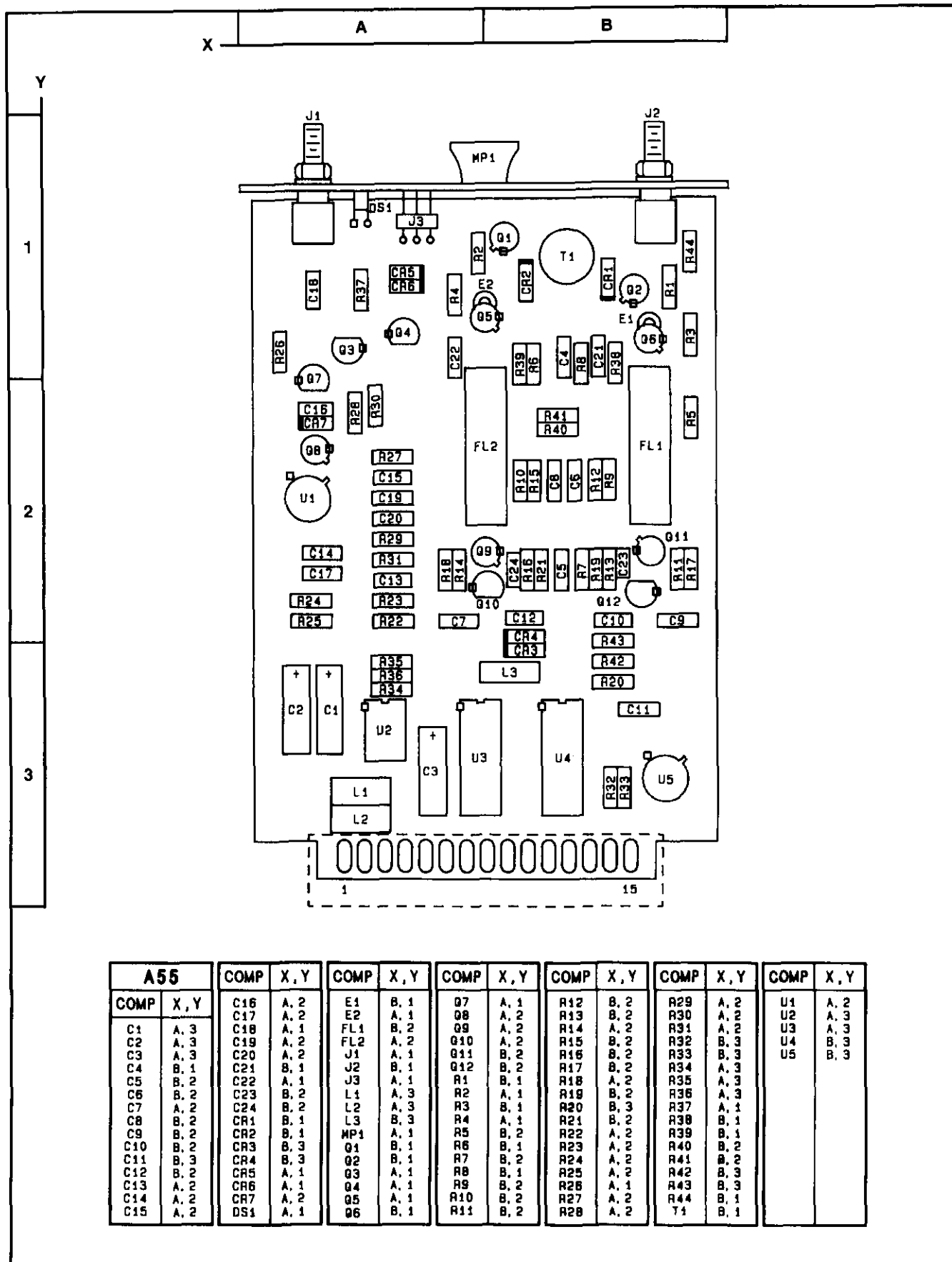

A55		COMP	X, Y	COMP	X, Y	COMP	X, Y	COMP	X, Y	COMP	X, Y	COMP	X, Y
COMP	X, Y	C16	A, 2	E1	B, 1	Q7	A, 1	R12	B, 2	R29	A, 2	U1	A, 2
C2	A, 3	C17	A, 2	E2	A, 1	Q8	A, 2	R13	B, 2	R30	A, 2	U2	A, 3
C3	A, 3	C18	A, 1	FL1	B, 2	Q9	A, 2	R14	A, 2	R31	A, 2	U3	A, 3
C4	B, 1	C19	A, 2	FL2	A, 2	Q10	A, 2	R15	B, 2	R32	B, 3	U4	B, 3
C5	B, 2	C20	A, 2	J1	A, 1	Q11	B, 2	R16	B, 2	R33	B, 3	U5	B, 3
C6	B, 2	C21	B, 1	J2	B, 1	Q12	B, 2	R17	B, 2	R34	A, 3		
C7	A, 2	C22	A, 1	J3	A, 1	R1	B, 1	R18	A, 2	R35	A, 3		
C8	B, 2	C23	B, 2	L1	A, 3	R2	A, 1	R19	B, 2	R36	A, 3		
C9	B, 2	C24	B, 2	L2	A, 3	R3	B, 1	R20	B, 3	R37	A, 1		
C10	B, 2	CR1	B, 1	L3	B, 3	R4	A, 1	R21	B, 2	R38	B, 1		
C11	B, 3	CR2	B, 1	MP1	A, 1	R5	B, 2	R22	A, 2	R39	B, 1		
C12	B, 2	CR3	B, 3	Q1	B, 1	R6	B, 1	R23	A, 2	R40	B, 2		
C13	A, 2	CR4	B, 3	Q2	B, 1	R7	B, 2	R24	A, 2	R41	B, 2		
C14	A, 2	CR5	A, 1	Q3	A, 1	R8	B, 1	R25	A, 2	R42	B, 3		
C15	A, 2	CR6	A, 1	Q4	A, 1	R9	B, 2	R26	A, 1	R43	B, 3		
		CR7	A, 2	Q5	A, 1	R10	B, 2	R27	A, 2	R44	B, 1		
		DS1	A, 1	Q6	B, 1	R11	B, 2	R28	A, 2	T1	B, 1		

A16 BUFFER AMPLIFIER
A17 INPUT MIXER
A18 IF AMPLIFIER
SS5
 SEE REVERSE SIDE SERIAL PREFIX: 2314A TO 2636A

A55 IF CHANNEL FILTER ASSEMBLY (OPTION 030 SERIES) (08901-60251)

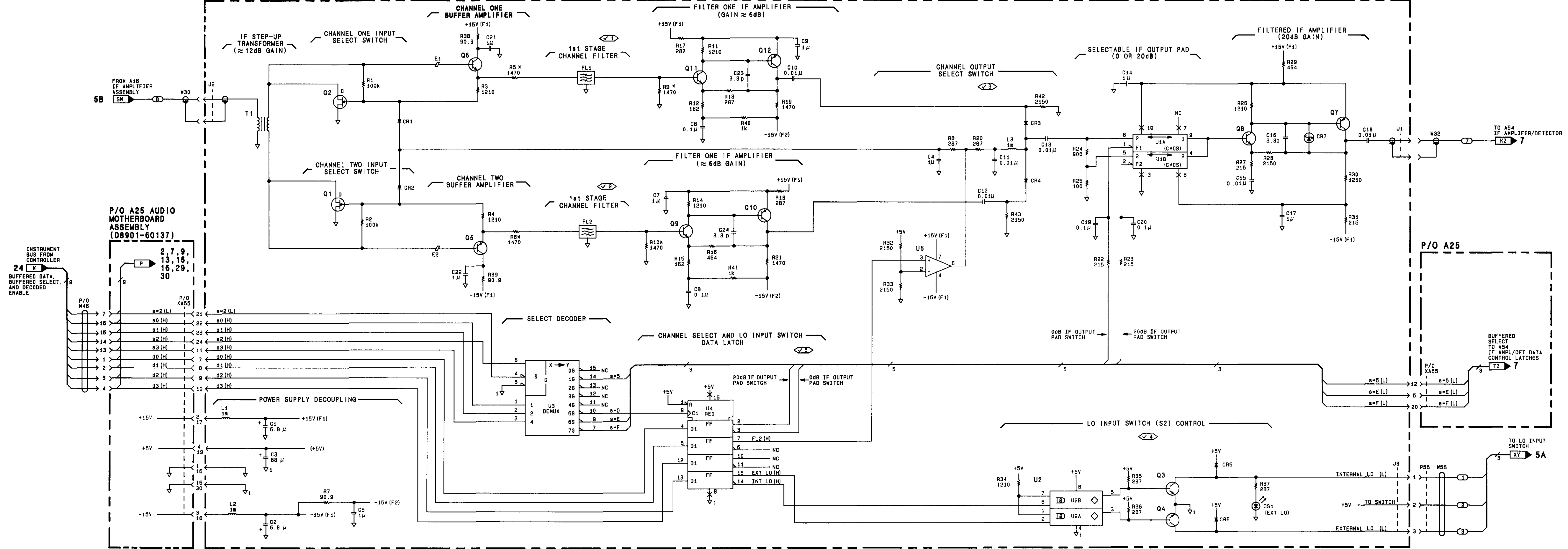

SERIAL PREFIX: 2314A TO 2636A

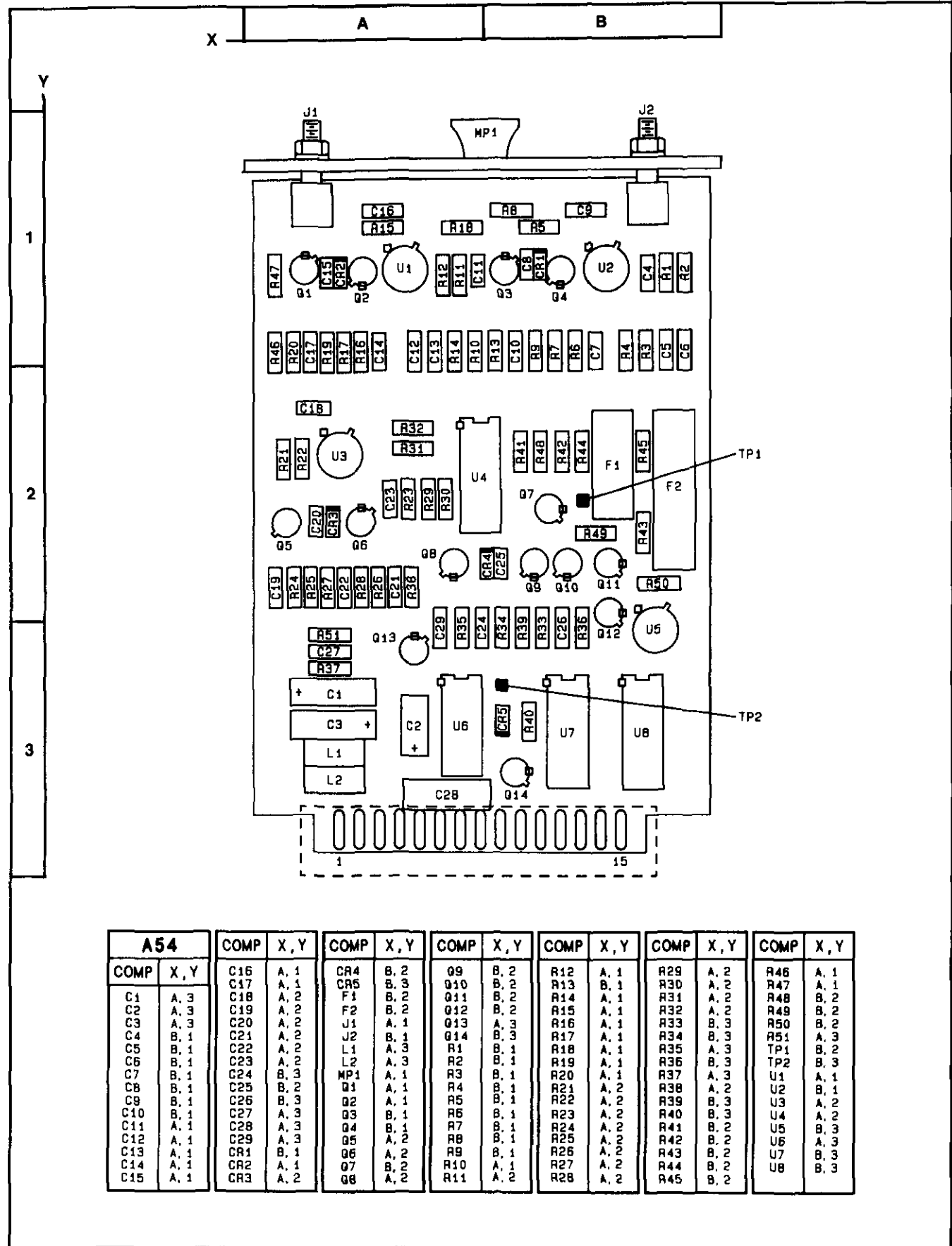

A55 IF CHANNEL FILTER **SS6**
 SEE REVERSE SIDE SERIAL PREFIX: 2314A T02536A

A54 IF AMPLIFIER/DETECTOR ASSEMBLY (OPTION 030 SERIES) (08901-60252)

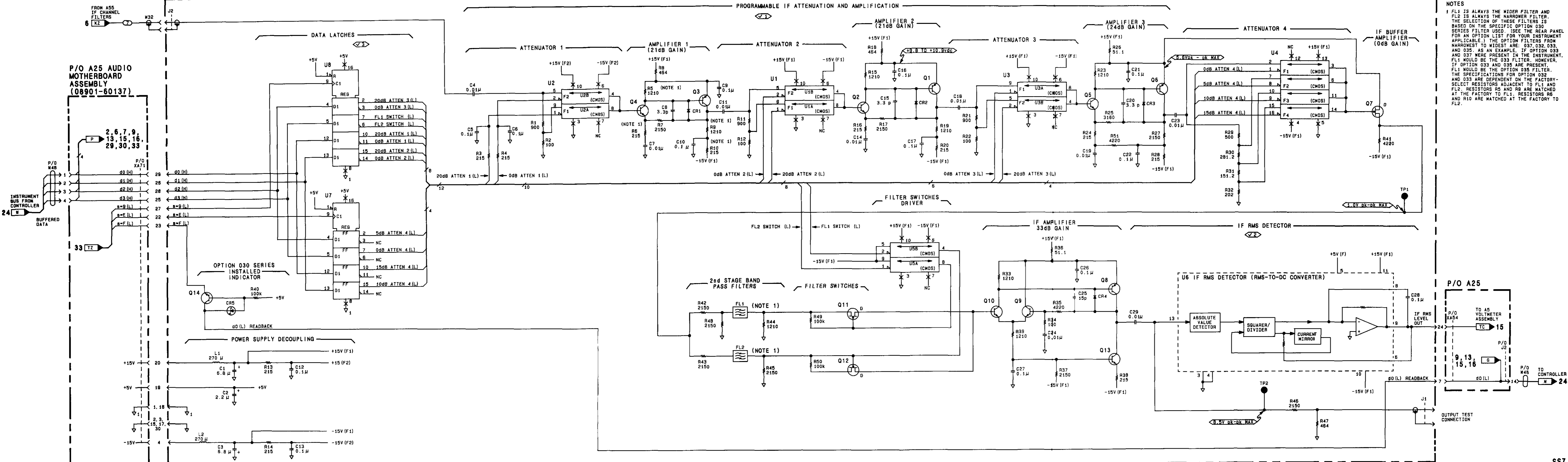

NOTES

1. FL1 IS ALWAYS THE WIDER FILTER AND FL2 IS ALWAYS THE NARROWER FILTER. THE SELECTION OF THESE FILTERS IS BASED ON THE SPECIFIC OPTION 030 SERIES FILTER USED. (SEE THE REAR PANEL FOR AN OPTION LIST FOR YOUR INSTRUMENT APPLICABLE.) THE OPTION FILTERS FROM NARROWEST TO WIDEST ARE: 037, 032, 033, AND 035. AS AN EXAMPLE, IF OPTION 033 AND 037 WERE PRESENT IN THE INSTRUMENT, FL1 WOULD BE THE 033 FILTER. HOWEVER, IF OPTION 033 AND 035 ARE PRESENT, FL1 WOULD BE THE OPTION 035 FILTER. THE SPECIFICATIONS FOR OPTION 032 AND 033 ARE DEPENDENT ON THE FACTORY-SELECT RESISTORS ADJACENT TO FL1 AND FL2. RESISTORS R5 AND R9 ARE MATCHED AT THE FACTORY TO FL1. RESISTORS R6 AND R10 ARE MATCHED AT THE FACTORY TO FL2.

P/O A25 AUDIO MOTHERBOARD ASSEMBLY (08901-60137)

2, 6, 7, 9, 13, 15, 16, 29, 30, 33

INSTRUMENT BUS FROM CONTROLLER

33 TZ

OPTION 030 SERIES INSTALLED INDICATOR

POWER SUPPLY DECOUPLING

15V (F1)
15V (F2)
+5V
-15V (F1)
-15V (F2)

SERIAL PREFIX: 2314A TO 2638A

P/O A25

TO A5 VOLTMETER ASSEMBLY
TC 15
9, 13, 15, 16
TO CONTROLLER
P/O W46
M 24

OUTPUT TEST CONNECTION

A6 Component Coordinates (1 of 2)

COMP	X,Y	COMP	X,Y	COMP	X,Y	COMP	X,Y	COMP	X,Y
C1	B,2	CR6	A,2	R9	B,2	R61	A,2		
C2	B,2	CR7	A,2	R10	B,2	R62	A,2		
C3	A,1	CR8	A,3	R13	B,2	R63	A,2		
C4	B,1	CR9	A,3	R14	B,2	R64	A,2		
C5	B,1	CR10	A,2	R14	B,2	R65	A,1		
C6	B,1	CR18	A,2	R15	B,2	R66	A,2		
C7	B,2	CR21	A,2	R15	B,2	R67	A,3		
C8	B,1			R16	B,2	R68	A,3		
C9	B,1	J1	A,1	R17	A,2	R69	A,2		
C11	B,2	J2	A,1	R18	A,3	R70	A,2		
C15	B,2			R19	B,2	R71	A,2		
C16	B,2	L1	B,2	R20	A,2	R72	A,2		
C17	B,2	L2	B,2	R21	A,2	R73	A,3		
C18	B,2	L3	A,1	R22	B,2	R74	A,3		
C19	B,2	L4	B,1	R23	B,2	R75	A,2		
C20	A,2	L5	B,1	R24	B,2	R76	A,2		
C21	B,2	L7	A,3	R25	B,2	R76	A,2		
C22	A,2	L8	A,3	R26	A,2	R77	A,2		
C23	A,2			R27	A,2	R78	A,2		
C24	A,2	Q1	A,1	R28	A,2	R80	A,3		
C25	A,2	Q2	A,2	R29	A,2	R81	A,3		
C26	A,2	Q4	A,2	R30	A,2	R82	A,3		
C29	A,2	Q5	A,2	R31	A,2	R87	A,3		
C30	A,2	Q6	A,2	R32	A,2	R88	A,2		
C32	A,2	Q7	B,2	R33	A,2	R124	A,2		
C34	A,2	Q8	B,2	R34	A,2	R126	A,2		
C36	A,1	Q13	A,2	R35	A,2	R128	A,3		
C37	A,2	Q14	A,2	R36	A,2				
C38	A,3	Q15	A,3	R37	A,2	TP1	A,1		
C39	A,2	Q16	A,3	R38	A,2	TP2	A,1		
C40	A,2	Q17	A,3	R39	A,2				
C41	A,2	Q18	A,3	R41	A,2	U1	A,2		
C42	A,2	Q19	A,3	R42	A,2	U2	A,2		
C43	A,3	Q20	A,2	R44	A,2	U3	A,2		
C44	A,3	Q21	A,2	R46	A,2	U4	B,2		
C45	A,2	Q31	A,2	R49	A,2	U5	A,2		
C46	A,2			R50	A,3				
C47	A,1	R1	A,1	R51	A,2	VR2	A,2		
C50	A,3	R2	B,1	R52	A,2	VR3	A,2		
C51	A,1	R3	B,2	R54	A,2	VR4	A,2		
C52	A,2	R4	B,2	R55	A,2				
C53	B,2	R5	B,2	R56	A,3				
C55	B,3	R6	B,2	R57	A,2				
C68	A,2	R7	B,2	R58	A,2				
C69	A,3	R8	A,2	R60	A,2				

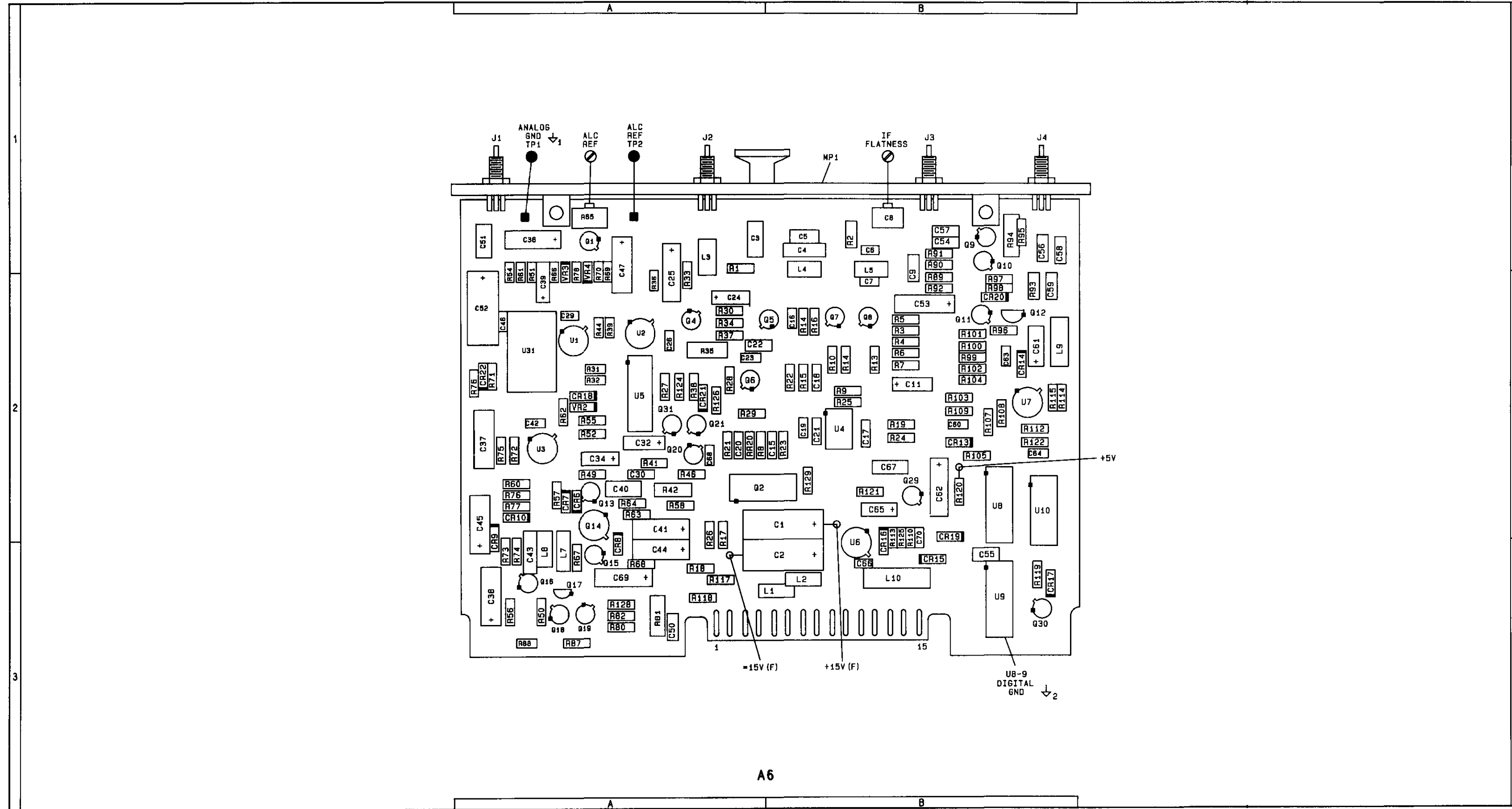

Component Locator

A54 IF AMPLIFIER/DETECTOR

SS7

SEE REVERSE SIDE SERIAL PREFIX: 2314A TO 2636A

P/O A6 AM DEMODULATOR ASSEMBLY (1 OF 2) (08901-60186)

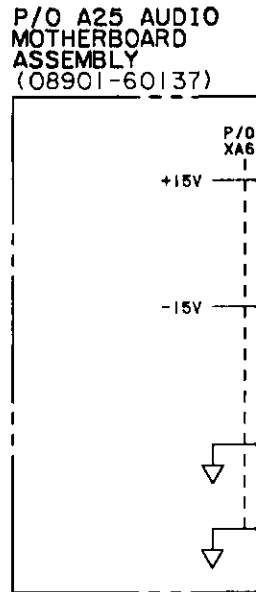
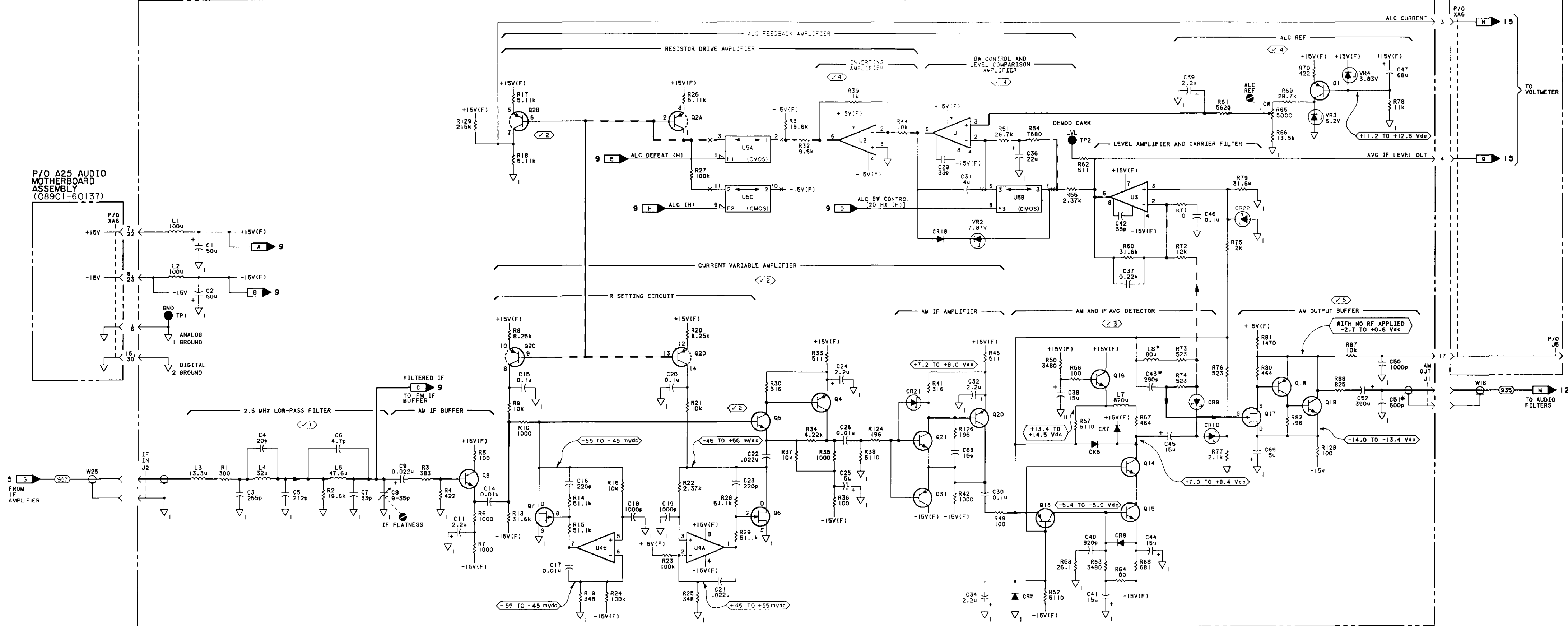

P/O A25



NOTES
1. SEE TABLE 8A-4 FOR SCHEMATIC DIAGRAM NOTES.

DIGITAL INTEGRATED CIRCUIT VOLTAGE AND GROUND CONNECTIONS

REFERENCE DESIGNATIONS	PIN NUMBERS
U5	+ 6V - 5
	↓ 2 - 12

A6 Component Coordinates (2 of 2)

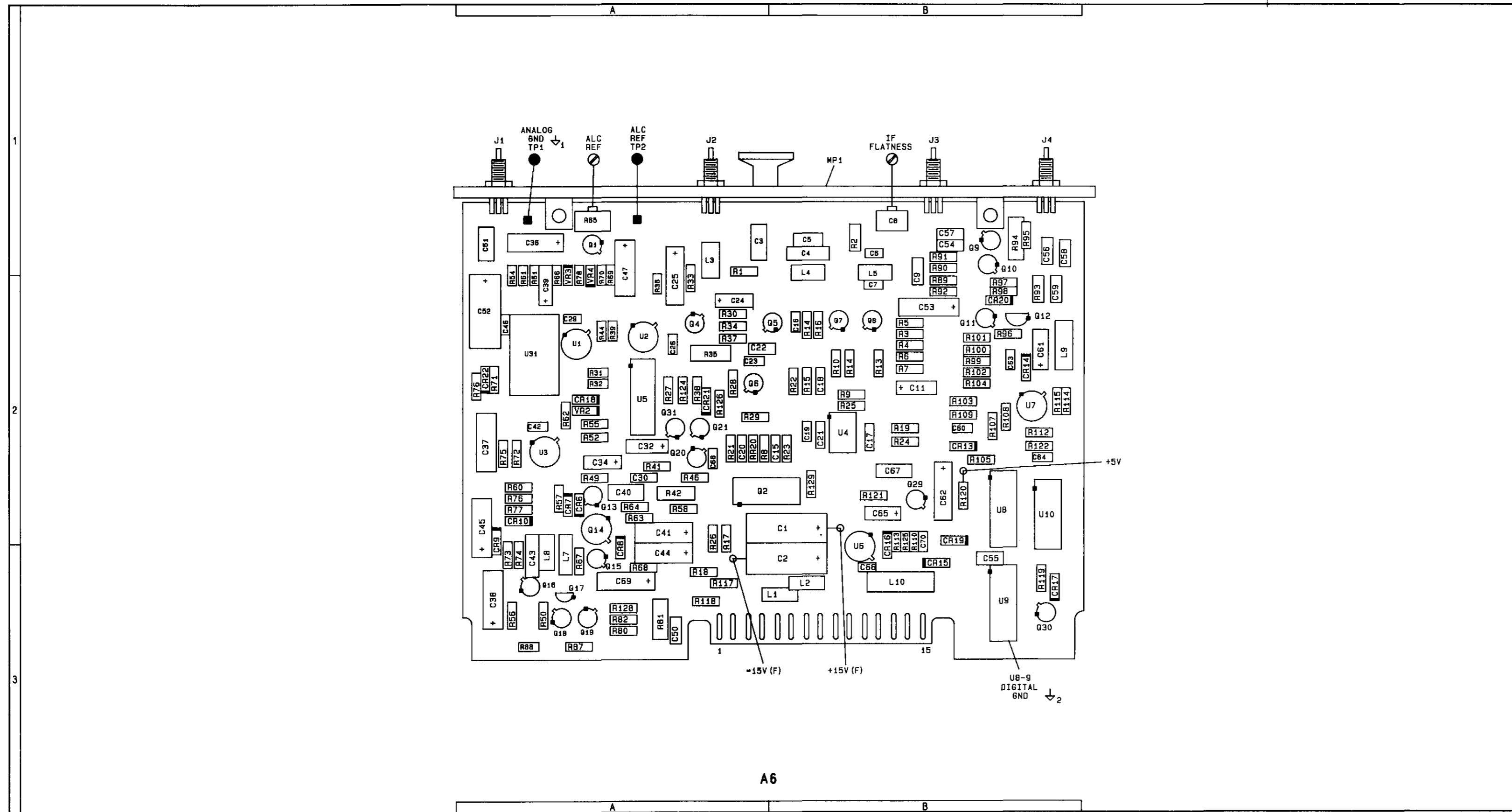

Component Locator

A54 AM DEMODULATOR (1 OF 2)
ALC LOOP

SS8

SEE REVERSE SIDE

COMP	X,Y	COMP	X,Y	COMP	X,Y	COMP	X,Y	COMP	X,Y
C54	B,1	R97	B,2						
C56	B,1	R98	B,2						
C57	B,1	R99	B,2						
C58	B,1	R100	B,2						
C59	B,2	R101	B,2						
C60	B,2	R102	B,2						
C61	B,2	R103	B,2						
C62	B,2	R104	B,2						
C63	B,2	R105	B,2						
C64	B,2	R107	B,2						
C65	B,2	R108	B,2						
C66	B,2	R109	B,2						
C67	B,2	R110	B,2						
C70	B,2	R112	B,2						
		R113	B,2						
CR13	B,2	R114	B,2						
CR14	B,2	R115	B,2						
CR15	B,2	R117	A,3						
CR16	B,2	R118	A,3						
CR17	B,2	R119	B,2						
CR19	B,2	R120	B,2						
CR20	B,2	R121	B,2						
CR22	A,2	R122	B,2						
		R125	B,2						
J3	B,1	R129	B,2						
J4	B,1	TP1	A,1						
L9	B,2	U6	B,3						
L10	B,3	U7	B,2						
		U8	B,2						
Q9	B,1	U9	B,2						
Q10	B,1	U10	B,2						
Q1	B,2	U31	A,2						
Q2	B,2								
Q29	B,2								
Q30	B,3								
R89	B,2								
R90	B,1								
R91	B,1								
R92	B,2								
R93	B,2								
R94	B,1								
R95	B,1								
R96	B,2								

P/O A6 AM DEMODULATOR ASSEMBLY (2 OF 2) (08901-60186)

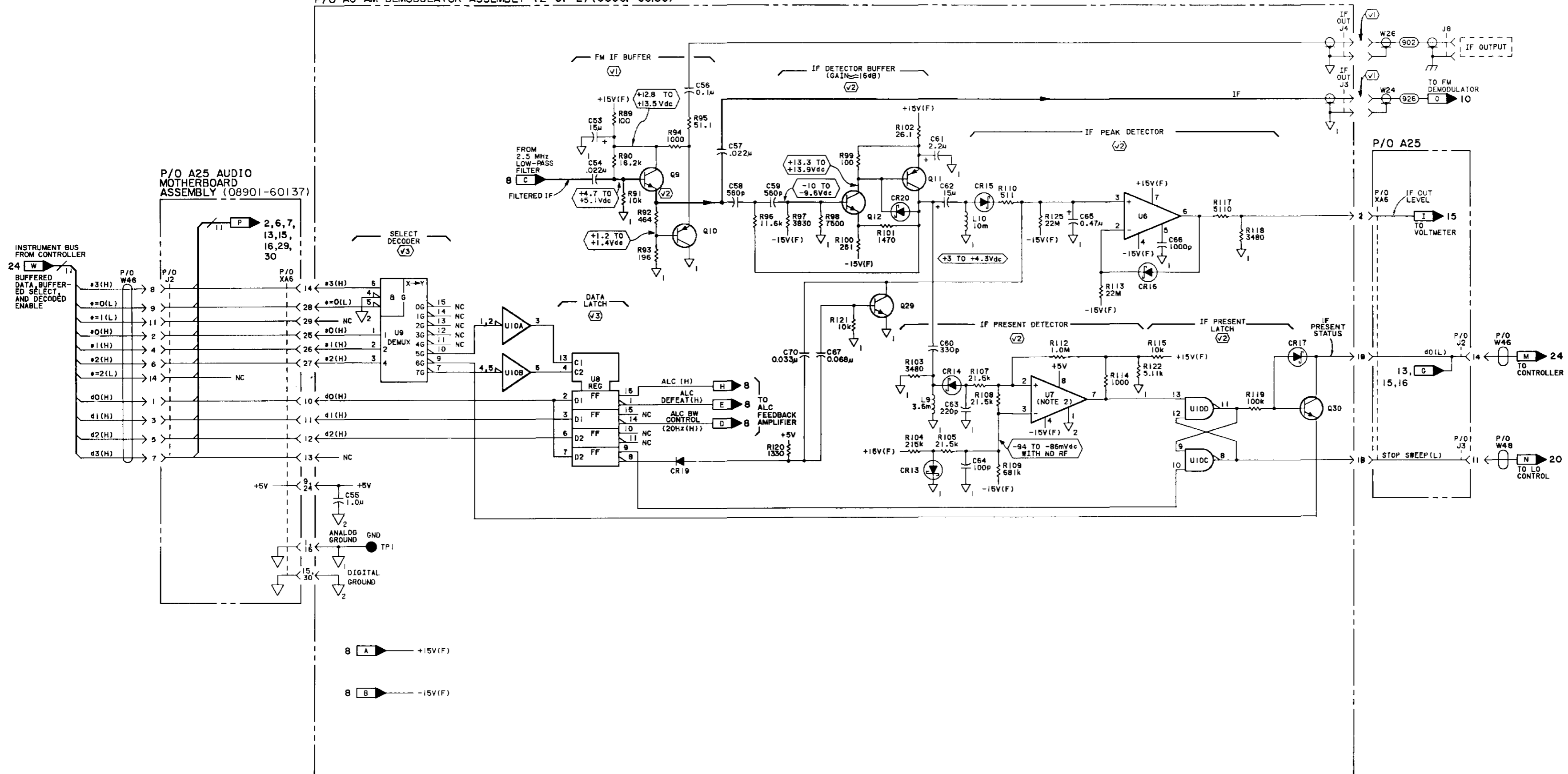

- NOTES
1. REFER TO TABLE BA-4 FOR SCHEMATIC DIAGRAM NOTES.
 2. THE DIAGRAM BELOW SHOWS THE OUTPUT STAGE OF COMPARATOR AGUT IN DETAIL.

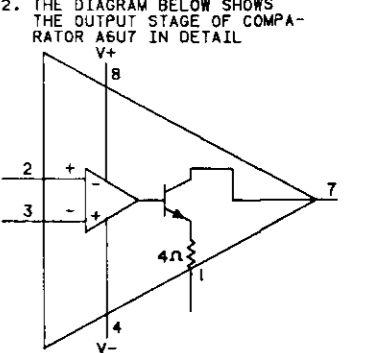

DIGITAL INTEGRATED CIRCUIT VOLTAGE AND GROUND CONNECTIONS

REFERENCE DESIGNATIONS	PIN NUMBERS
U8	+5V - 5
	⏚ - 12
U9	+5V - 16
	⏚ - 8
U10	+5V - 14
	⏚ - 7

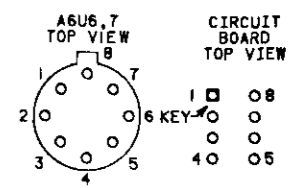

A4 Component Coordinates (1 of 2)

COMP	X,Y	COMP	X,Y	COMP	X,Y	COMP	X,Y	COMP	X,Y
C1	A,2	R10	A,3						
C2	A,2	R11	A,3						
C3	A,3	R12	A,3						
C4	A,3	R13	A,3						
C5	A,3	R14	A,3						
C6	A,3	R15	A,3						
C7	A,3	R16	A,3						
C8	A,3	R17	A,2						
C9	A,3	R18	A,2						
C10	A,2	R19	A,2						
C11	A,2	R20	A,2						
C12	A,2	R21	A,2						
C13	A,2	R22	A,2						
C14	A,2	R23	A,2						
C15	A,2	R24	A,2						
C16	A,2	R25	A,2						
C17	A,2	R26	A,2						
C18	A,1	R27	A,2						
C19	A,1	R28	A,2						
C20	A,1	R29	A,2						
		R30	A,2						
CR1	A,3	R31	A,2						
CR2	A,3	R32	A,2						
		R33	A,2						
		R34	A,2						
		R35	A,1						
J1	A,1	R36	A,2						
J2	A,1	R37	A,1						
		R38	A,1						
MP1	B,1	R39	A,1						
		R40	A,1						
Q1	A,1	R41	A,1						
Q11	A,2	R42	A,1						
Q20	A,3								
Q30	A,3	TP1	A,1						
		TP2	A,1						
R1	A,3								
R2	A,2								
R3	A,3								
R4	A,3								
R5	A,3								
R6	A,3								
R7	A,3								
R8	A,3								
R9	A,3								

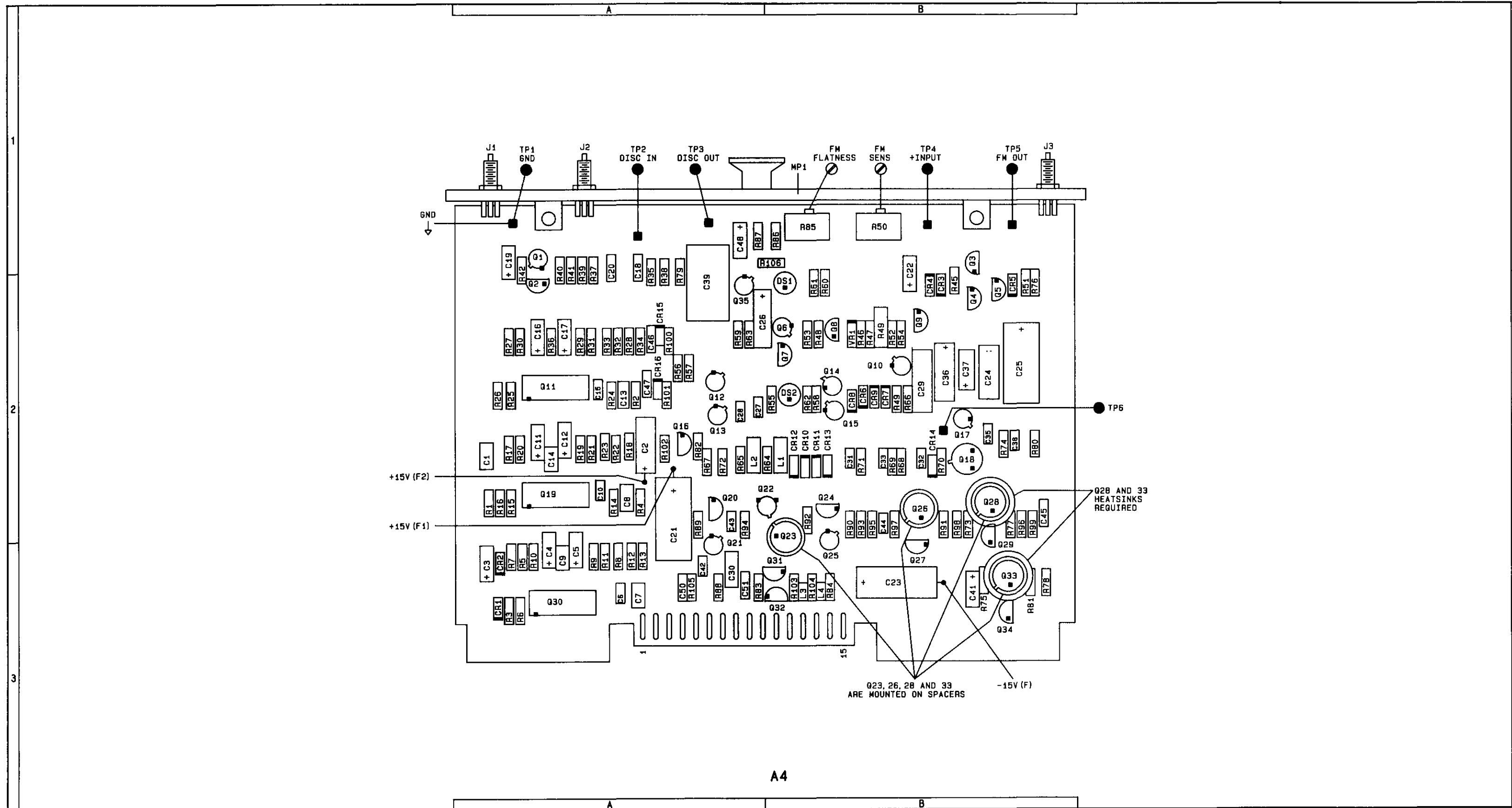

Component Locator

A6 AM DEMODULATOR (2 OF 2)
CONTROL CIRCUITS
SEE REVERSE SIDE

SS9

P/O A4 FM DEMODULATOR ASSEMBLY (08901-60184) (1 OF 2)

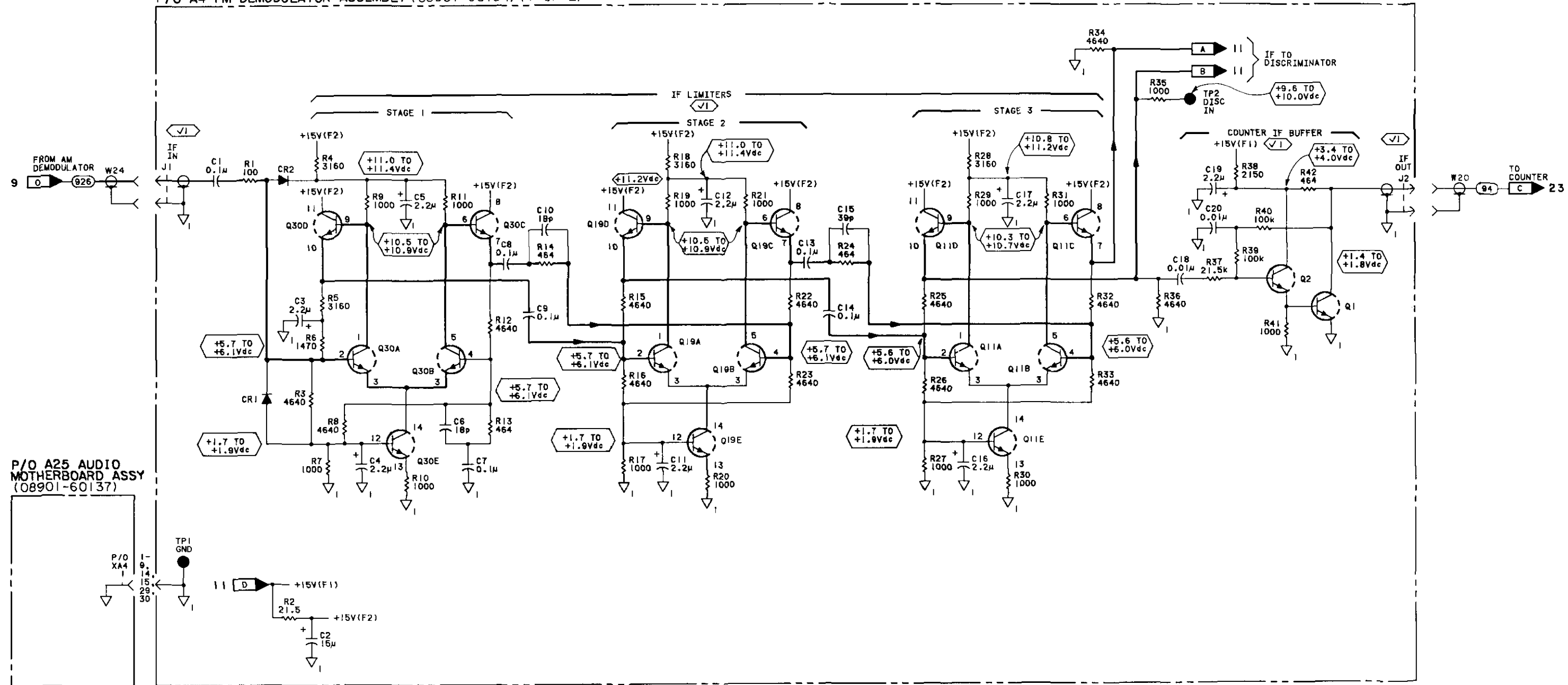

NOTES
1. SEE TABLE 8A-4 FOR SCHEMATIC DIAGRAM NOTES.

A4 Component Coordinates (2 of 2)

COMP	X,Y	COMP	X,Y	COMP	X,Y	COMP	X,Y	COMP	X,Y
C21	A,3	J3	B,1	R50	B,1	R95	B,2		
C22	B,1			R51	B,2	R96	B,2		
C23	B,3	L1	B,2	R52	B,1	R97	B,2		
C24	B,2	L2	A,2	R53	B,2	R98	B,2		
C25	B,2	L3	B,3	R54	B,1	R99	B,2		
C26	A,2	L4	B,3	R55	B,1	R100	A,2		
C27	A,2			R56	A,2	R101	A,2		
C28	A,2	Q2	B,2	R57	A,2	R102	A,2		
C29	B,2	Q3	B,2	R58	B,1	R103	B,3		
C30	A,3	Q4	B,2	R59	A,2	R104	B,3		
C31	B,2	Q5	B,2	R60	B,1	R105	A,3		
C32	B,2	Q6	B,2	R61	B,1	R106	B,1		
C33	B,2	Q7	B,2	R62	B,1				
C35	B,2	Q8	B,2	R63	A,2	TP3	A,1		
C36	B,2	Q9	B,1	R64	B,2	TP4	B,1		
C37	B,2	Q10	B,2	R65	A,2	TP5	B,1		
C38	B,2	Q12	A,2	R66	B,1	TP6	B,2		
C39	A,1	Q13	A,2	R67	A,2				
C41	B,3	Q14	B,1	R68	B,2	VR1	B,2		
C42	A,3	Q15	B,1	R69	B,2				
C43	A,3	Q16	A,2	R70	B,2				
C44	B,2	Q17	B,2	R71	B,2				
C45	B,2	Q18	B,2	R72	A,2				
C46	A,2	Q19	A,3	R73	B,2				
C47	A,2	Q21	A,3	R74	B,2				
C48	A,1	Q22	A,3	R75	B,3				
C50	A,3	Q23	B,2	R76	B,2				
C51	A,3	Q24	B,2	R77	B,2				
		Q25	B,3	R78	B,3				
CR3	B,2	Q26	B,2	R79	A,1				
CR4	B,2	Q27	B,3	R80	B,2				
CR5	B,2	Q28	B,2	R81	B,3				
CR6	B,2	Q29	B,3	R82	A,2				
CR7	B,2	Q31	B,3	R83	A,3				
CR8	B,2	Q32	B,3	R84	B,3				
CR9	B,2	Q33	B,3	R85	B,1				
CR10	B,2	Q34	B,3	R86	B,1				
CR11	B,2	Q35	A,2	R87	A,1				
CR12	B,2			R88	A,3				
CR13	B,2	R45	B,2	R89	A,3				
CR14	B,2	R46	B,2	R90	B,2				
CR15	A,2	R47	B,2	R91	B,2				
CR16	A,2	R48	B,2	R92	B,2				
		R49	B,1	R93	B,2				
DS2	B,1	R49	B,1	R94	A,3				

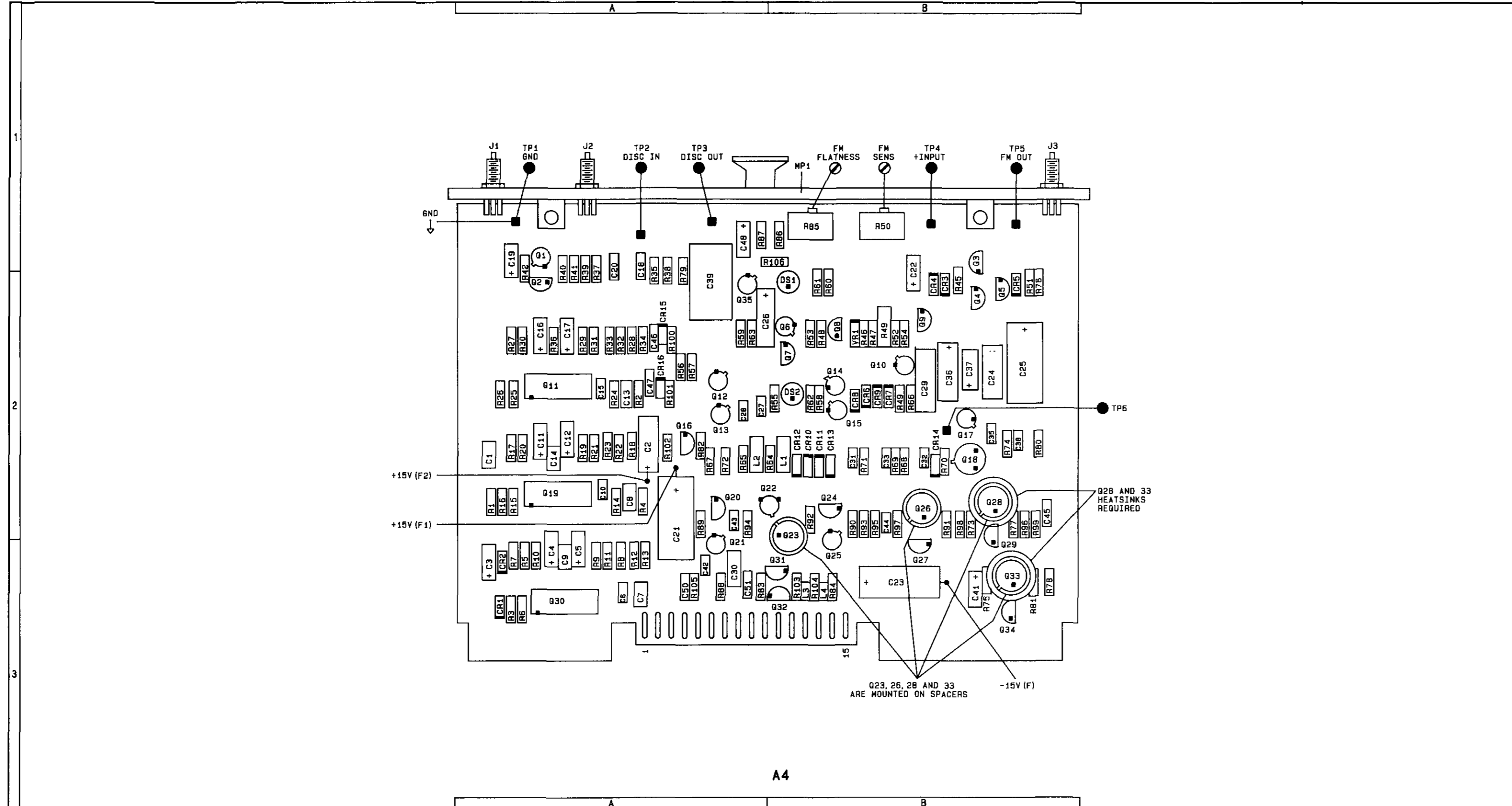

Component Locator

A4 FM DEMODULATOR (1 OF 2)
FM LIMITER CIRCUITS
SEE REVERSE SIDE

SS10

P/O A4 FM DEMODULATOR ASSEMBLY (2 OF 2) (08901-60184)

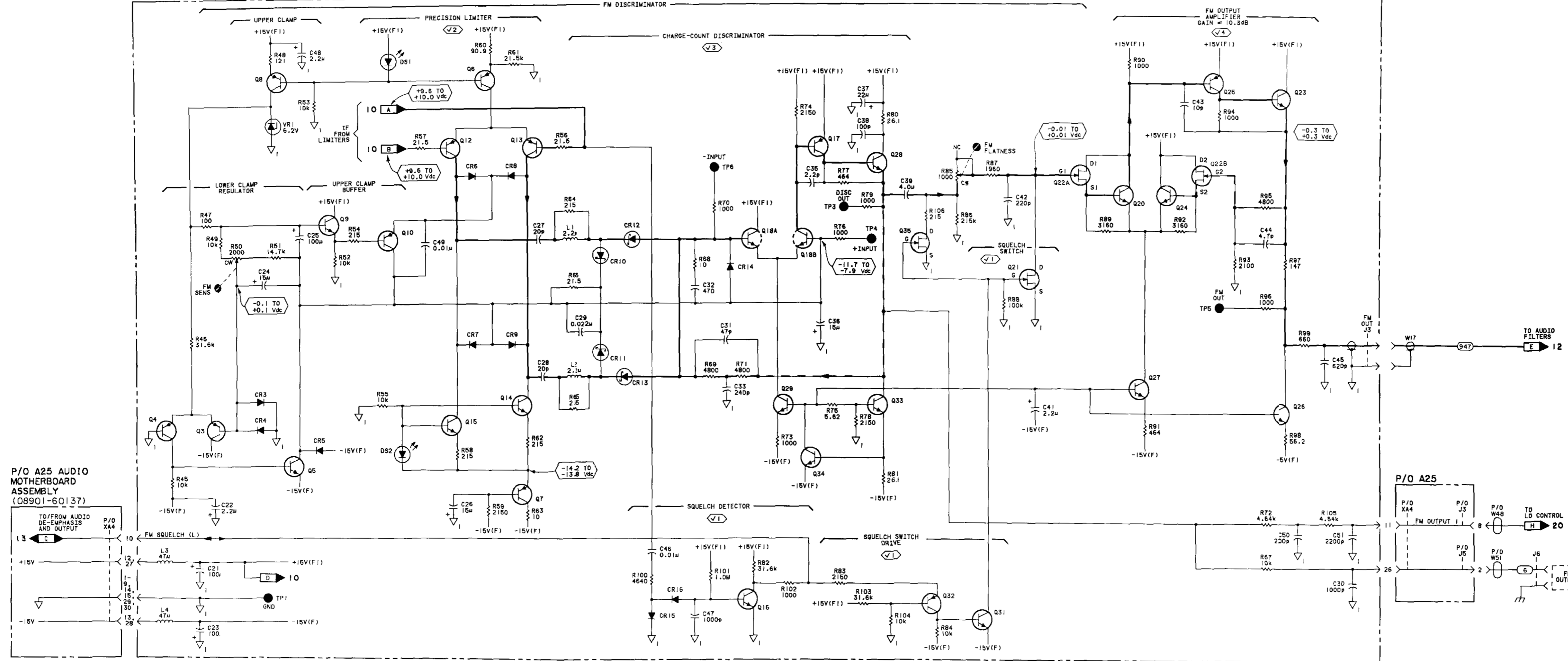

P/O A25 AUDIO MOTHERBOARD ASSEMBLY (08901-60137)

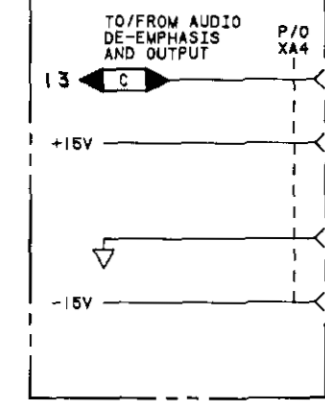

NOTES
1. SEE TABLE BA-4 SCHEMATIC DIAGRAM NOTES.

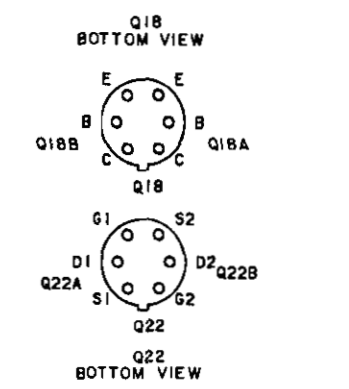

SS11
8G-25

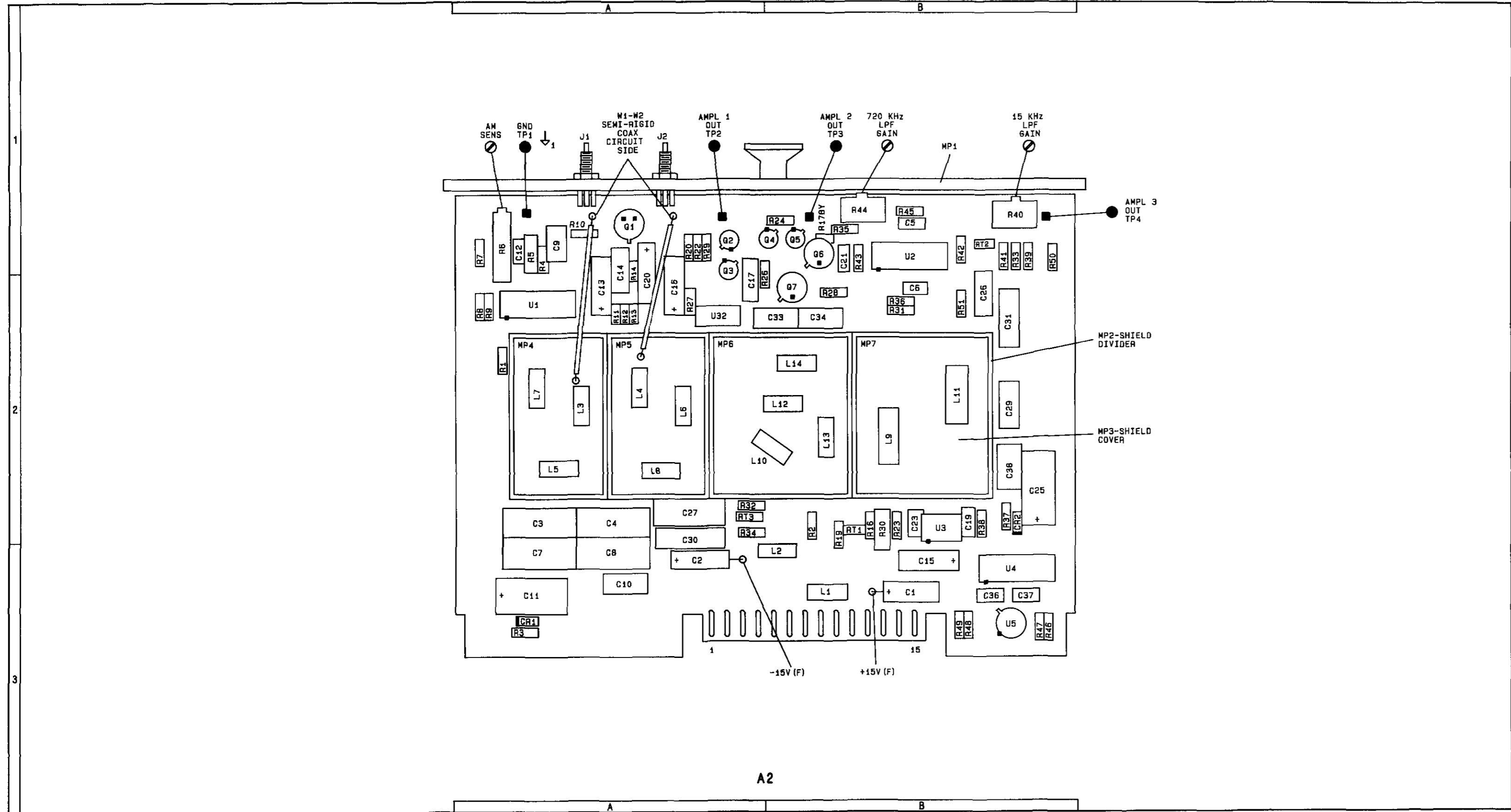

Component Locator

A4 FM DEMODULATOR (2 OF 2)
FM DISCRIMINATOR CIRCUITS
SEE REVERSE SIDE

SS11

A2 Component Coordinates

COMP	X,Y	COMP	X,Y	COMP	X,Y	COMP	X,Y	COMP	X,Y
C1	B,3	L7	A,2	R24	B,1				
C2	A,3	L8	A,2	R26	A,2				
C3	A,2	L9	B,2	R27	A,2				
C4	A,2	L10	B,2	R28	B,2				
C5	B,1	L11	B,2	R29	A,1				
C6	B,2	L12	B,2	R30	B,2				
C7	A,3	L13	B,2	R31	B,1				
C8	A,3	L14	B,2	R31	B,2				
C9	A,1			R32	A,2				
C10	A,3	MP1	B,1	R33	B,1				
C11	A,3	MP2	B,2	R34	A,2				
C12	A,1	MP3	B,2	R35	B,1				
C13	A,2	MP4	A,2	R36	B,2				
C14	A,1	MP5	A,2	R37	B,2				
C15	B,3	MP6	A,2	R38	B,2				
C16	A,2	MP7	B,2	R39	B,1				
C17	A,1			R40	B,1				
C19	B,2	Q1	A,1	R41	B,1				
C20	A,2	Q2	A,1	R42	B,1				
C21	B,1	Q3	A,1	R43	B,1				
C23	B,2	Q4	B,1	R44	B,1				
C25	B,2	Q5	B,1	R45	B,1				
C26	B,2	Q6	B,1	R46	B,3				
C27	A,2	Q7	B,2	R47	B,3				
C29	B,2			R48	B,3				
C30	A,3	R1	A,2	R49	B,3				
C31	B,2	R2	B,2	R50	B,1				
C33	B,2	R3	A,3	R51	B,2				
C34	B,2	R4	A,1						
C36	B,3	R5	A,1	RT1	B,2				
C37	B,3	R6	A,1	RT2	B,1				
C38	B,2	R7	A,1	RT3	A,2				
		R8	A,2						
CR1	A,3	R9	A,2	TP1	A,1				
CR2	B,2	R10	A,1	TP2	A,1				
		R11	A,2	TP3	B,1				
J1	A,1	R12	A,2	TP4	B,1				
J2	A,1	R13	A,2						
		R14	A,1	U1	A,2				
L1	B,3	R16	B,2	U2	B,1				
L2	B,3	R17	B,1	U3	B,2				
L3	A,2	R19	B,2	U4	B,3				
L4	A,2	R20	A,1	U5	B,3				
L5	A,2	R22	A,1						
L6	A,2	R23	B,2						

A2 AUDIO FILTERS ASSEMBLY (08901-60008)

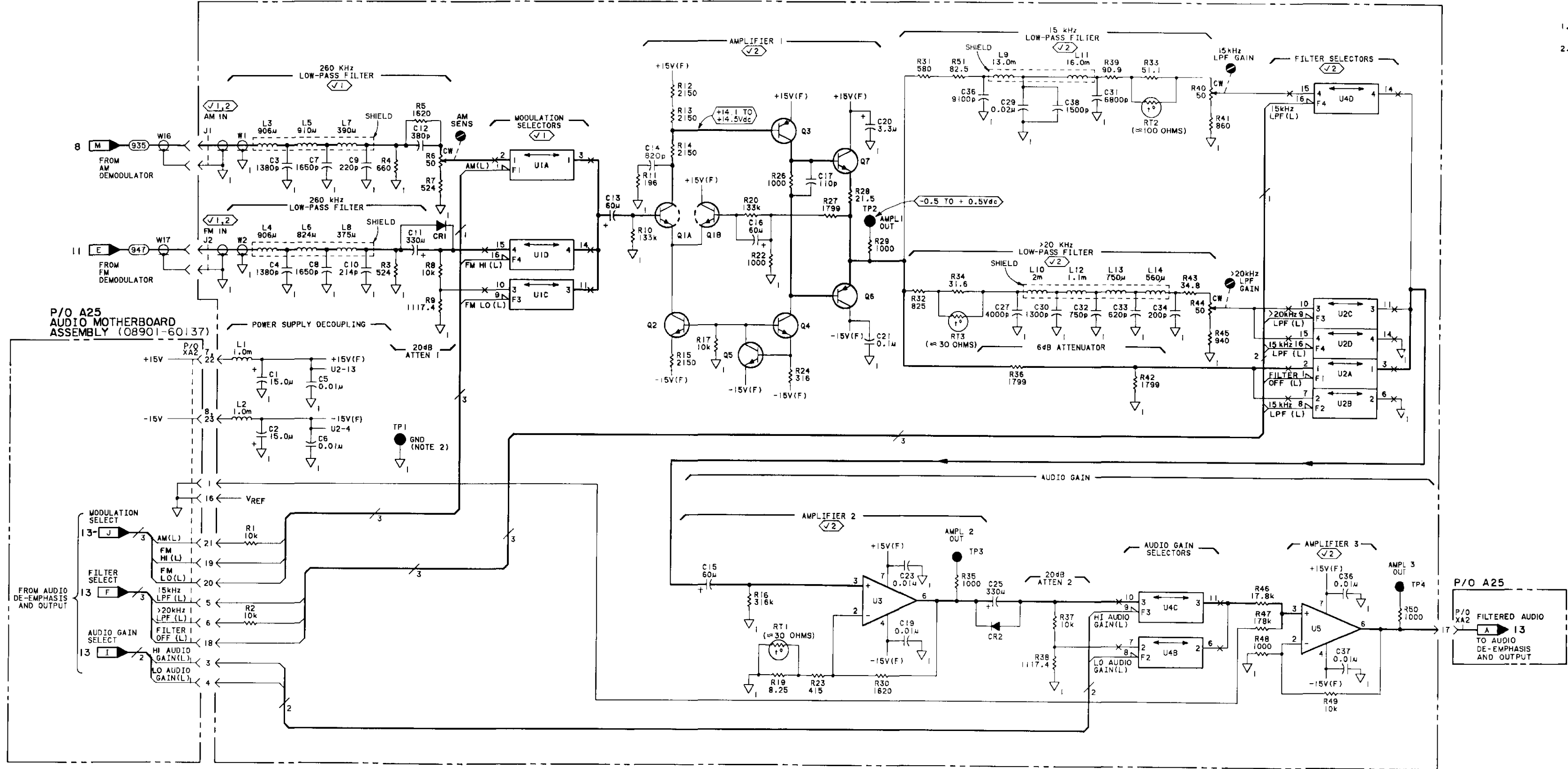

NOTES

1. REFER TO TABLE 8A-4 FOR SCHEMATIC DIAGRAM NOTES.
2. ANALOG GROUND CONNECTION IS MADE THROUGH THE SHIELD OF W16 AND W17.

DIGITAL INTEGRATED CIRCUIT VOLTAGE AND GROUND CONNECTIONS

REFERENCE DESIGNATIONS	PIN NUMBERS
U1, 2, 4	+15V(F) - 13
	-15V(F) - 4
	VREF - 5

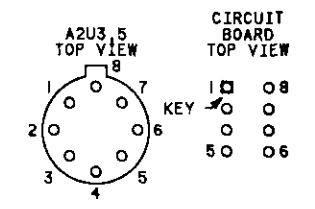

A3 Component Coordinates

COMP	X,Y	COMP	X,Y	COMP	X,Y	COMP	X,Y	COMP	X,Y
C1	A,3	C50	A,2	R5	B,2	R55	A,2	VR5	A,2
C2	A,3	C51	A,2	R7	A,1	R56	A,2		
C3	A,2	C52	A,2	R8	A,1	R57	B,3		
C4	A,2	C53	A,2	R9	A,1	R59	B,3		
C5	A,2	C55	B,2	R11	A,1	R60	B,3		
C6	A,2	C56	B,2	R12	A,1	R61	B,2		
C7	A,2	C57	B,2	R13	B,1	R62	B,2		
C8	A,2	C58	A,2	R14	A,2	R63	B,1		
C9	A,2	C59	A,2	R16	A,2	R64	A,2		
C10	B,2	C60	A,2	R17	A,2	R65	A,2		
C11	B,2	C61	B,3	R18	A,2				
C12	B,2	C62	B,3	R19	A,3	TP1	A,1		
C13	B,2	C64	A,2	R20	B,1	TP2	A,1		
C14	B,2	C65	A,2	R21	B,2	TP3	A,1		
C15	A,2	C68	A,3	R22	A,2	TP4	A,1		
C16	B,2	C69	A,3	R23	B,1	TP5	B,1		
C17	A,2	C70	B,2	R25	A,2				
C18	B,2	C72	A,1	R26	B,2	U1	A,2		
C19	B,3	C73	A,2	R27	A,1	U2	A,2		
C20	B,3	C74	A,3	R28	A,2	U3	A,2		
C21	B,3	C75	A,3	R29	A,2	U4	B,1		
C22	B,3	C76	A,2	R30	B,2	U5	B,1		
C23	B,2	C77	A,2	R31	A,2	U6	B,1		
C24	A,1			R32	A,2	U7	A,2		
C25	A,1	CR1	B,1	R33	A,3	U8	A,2		
C26	A,1	CR2	B,1	R34	A,2	U9	A,2		
C27	B,2	CR3	A,2	R35	A,2	U10	A,3		
C28	B,2	CR4	B,1	R36	A,2	U11	A,3		
C29	B,2	CR5	B,1	R37	A,2	U12	A,2		
C30	B,2	CR6	B,1	R38	A,2	U13	A,2		
C31	B,2	CR7	B,1	R39	A,2	U14	A,2		
C32	B,2	CR9	B,3	R40	A,2	U15	A,2		
C33	B,1			R41	A,2	U16	B,2		
C34	A,2	L1	B,3	R43	A,3	U17	B,2		
C36	B,1	L2	B,2	R44	A,3	U18	B,2		
C37	A,2	L3	B,3	R45	A,2	U19	B,2		
C39	B,1			R46	A,2	U20	B,2		
C40	B,1	MP1	B,1	R47	A,3	U21	B,2		
C41	B,2			R48	A,3	U22	B,2		
C42	A,2	Q1	B,2	R49	A,2	U23	B,3		
C43	A,2			R50	A,3				
C44	B,1	R1	A,1	R51	A,3	VR1	A,2		
C47	A,3	R2	A,2	R52	A,3	VR2	A,3		
C48	A,2	R3	A,2	R53	A,3	VR3	A,3		
C49	A,3	R4	A,2	R54	A,3	VR4	A,2		

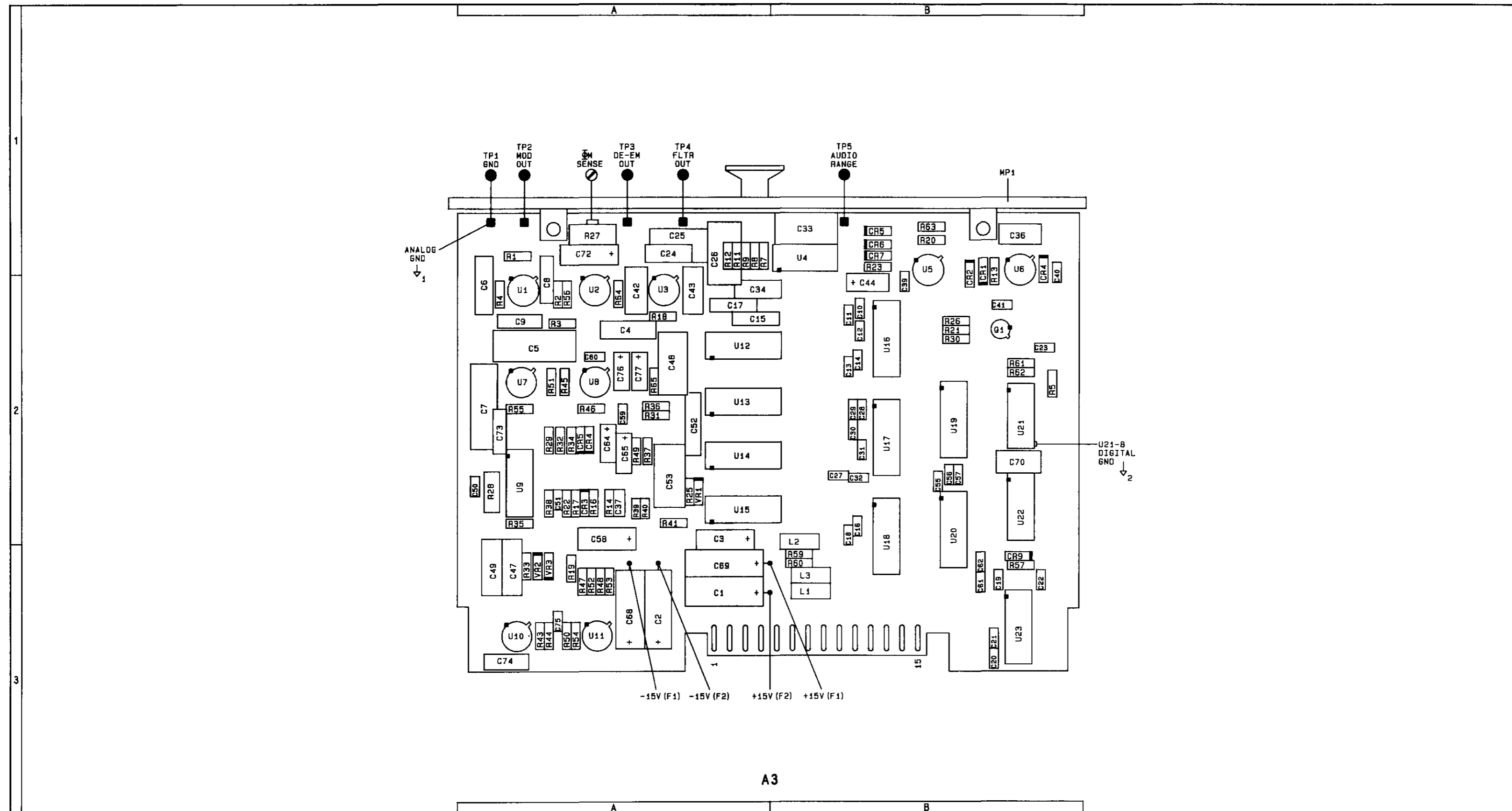

Component Locator

A2 AUDIO FILTERS

SS12

SEE REVERSE SIDE

CHANGES

<p>All Serial Prefixes</p>	<p>On the A3 Schematic:</p> <ul style="list-style-type: none"> • 08901-60009 - Use the partial schematic on page 8G-28.3. • L2, L3 - On the left side of the schematic, change L2 to L3, and change L3 to L2. <p>On the Component Locator:</p> <ul style="list-style-type: none"> • L2, L3 - Change L2 to L3, and change L3 to L2.
<p>2514A and above</p>	<p>On the A3 Schematic:</p> <ul style="list-style-type: none"> • C4, C6, C47 - Change the value of C4, C6 and C47 to 0.03μF. • C48, C53 - Change the value of C48 and C53 to 3900pF. • R1, R29 - Change the value of R1 and R29 to 25 k. • R4 - Change the value of R4 to 12.5 k. • R36 - Change the value of R36 to 7400.
<p>2619A and above</p>	<p>On the A25 Schematic:</p> <ul style="list-style-type: none"> • 08901-60116 - Change the part number of the A25 AUDIO MOTHERBOARD ASSEMBLY to 08901-60116.
<p>Errata</p>	<p>On the A3 Schematic:</p> <ul style="list-style-type: none"> • R51, R55 - Under INVERTING/NON-INVERTING AMPLIFIER, change the value of R51 and R55 to 1 k.

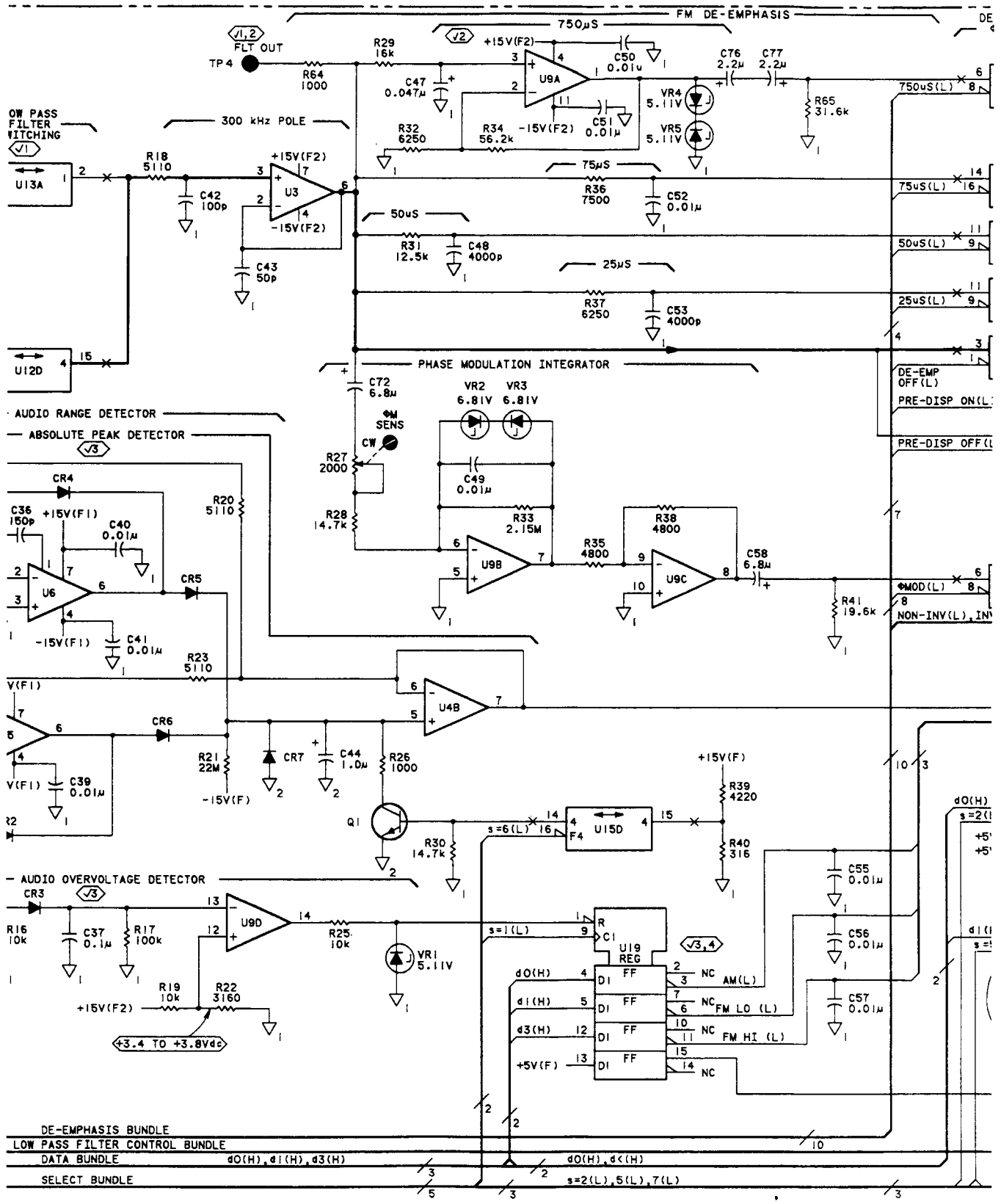

A3 AUDIO DE-EMPHASIS AND OUTPUT ASSEMBLY (P/O ERRATA)

A3 AUDIO DE-EMPHASIS AND OUTPUT ASSEMBLY (08901-60009)

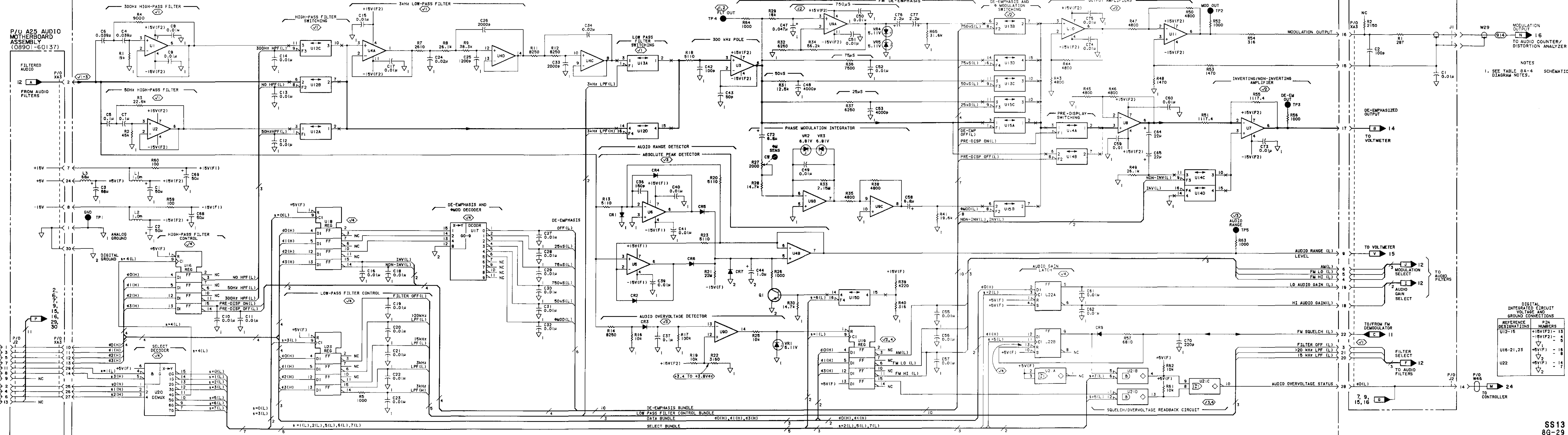

NOTES
1. SEE TABLE BA-4
SCHEMATIC
DIAGRAM NOTES.

DIGITAL INTEGRATED CIRCUIT VOLTAGE AND GROUND CONNECTIONS

DESIGNATIONS	PIN NUMBERS
U12-15	+15V(F2) - 13
	-15V(F2) - 6
U16-21,25	+5V(F) - 18
	+5V(F) - 14
U22	+5V(F) - 14

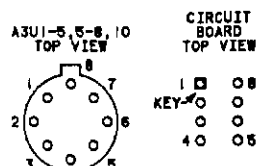

A5 Component Coordinates (1 of 2)

COMP	X,Y	COMP	X,Y	COMP	X,Y	COMP	X,Y	COMP	X,Y
C1	B,2	Q6	B,2	R42	B,2				
C2	B,3	Q7	B,2	R43	B,2				
C3	B,3								
C4	B,3	R1	B,2	TP4	A,1				
C5	B,2	R2	A,1	TP5	A,1				
C6	B,2	R3	B,2	TP6	B,1				
C7	B,2	R4	B,2	TP7	B,1				
C8	B,2	R5	B,2						
C9	B,2	R6	A,2	U1	A,2				
C10	B,2	R7	B,2	U3	B,2				
C11	A,1	R8	B,2	U4	B,2				
C12	A,2	R9	B,3	U8	B,2				
C13	B,2	R10	A,2	U9	B,2				
C14	A,2	R11	B,2	U15	B,3				
C15	A,2	R12	B,2	U16	B,3				
C16	B,2	R13	B,2						
C17	B,2	R14	B,2	VR1	B,2				
C18	B,1	R15	B,2	VR2	A,2				
C18	B,2	R16	B,2						
C19	B,2	R17	B,2						
C20	B,2	R18	B,1						
C35	B,2	R19	B,2						
		R20	A,2						
CR1	B,2	R21	B,2						
CR2	B,3	R22	A,2						
CR3	A,3	R23	A,1						
CR4	B,3	R24	A,2						
CR5	B,2	R25	B,2						
CR6	B,2	R26	A,2						
CR7	B,3	R27	B,2						
CR8	A,2	R28	A,2						
CR9	B,2	R29	B,2						
CR10	B,2	R30	B,2						
CR11	B,2	R31	B,2						
CR12	B,2	R32	B,2						
		R33	B,2						
L1	B,3	R34	B,2						
MP1	B,1	R35	B,2						
		R36	B,2						
Q1	A,2	R37	B,2						
Q2	B,2	R38	B,1						
Q3	B,2	R39	B,2						
Q5	B,2	R40	B,2						
		R41	B,2						

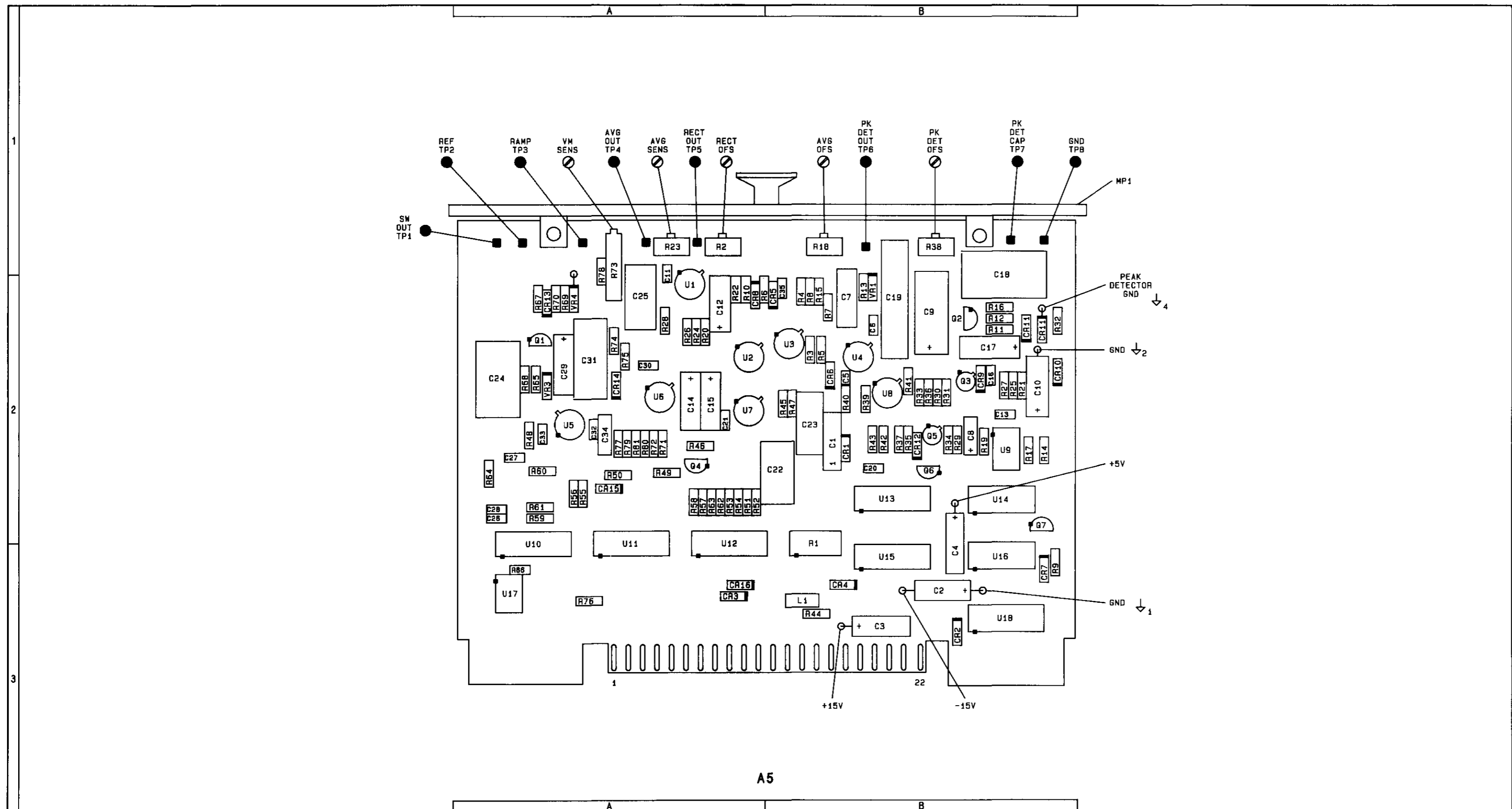

Component Locator

A3 AUDIO DE-EMPHASIS AND OUTPUT

SS 13

SEE REVERSE SIDE

P/O A5 VOLTMETER ASSEMBLY (1 OF 2) (08902-60005)

P/O A25 AUDIO MOTHERBOARD ASSEMBLY (08901-60137)

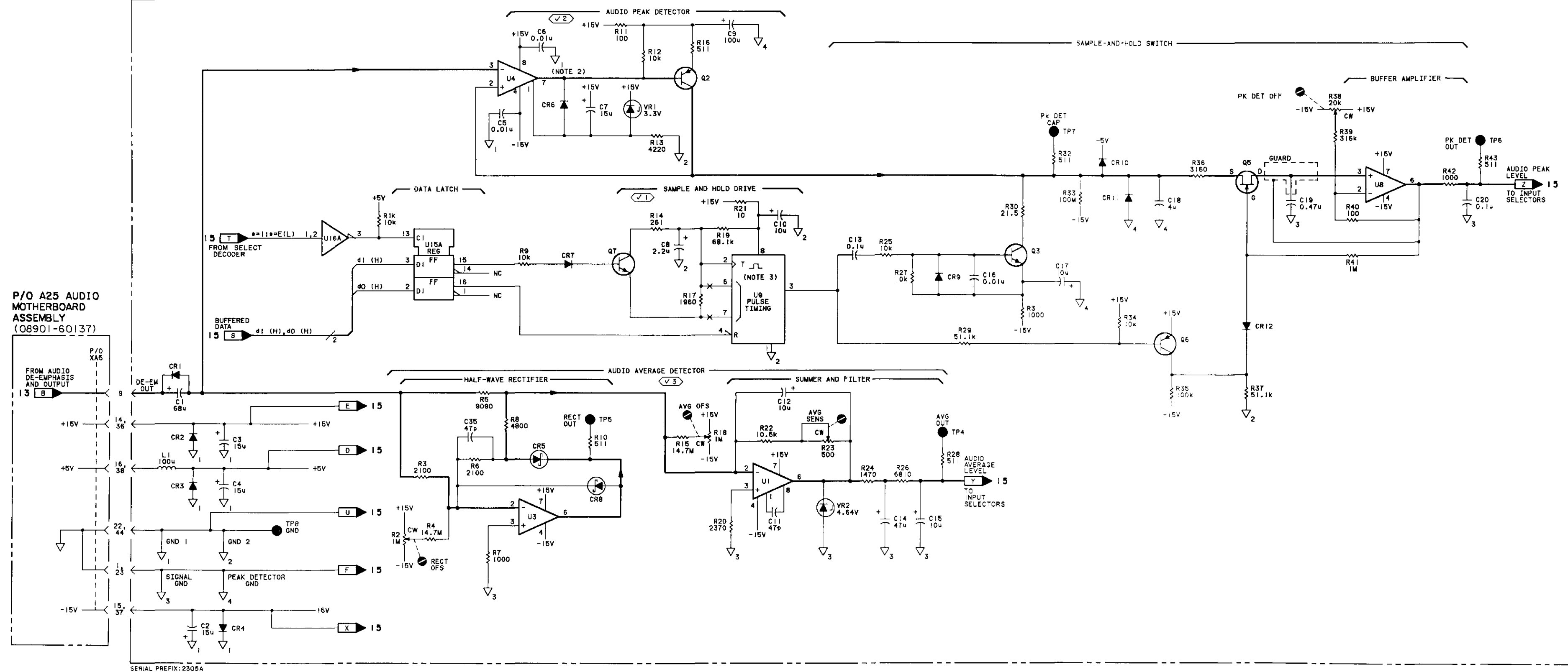

1. SEE TABLE BA-4 SCHEMATIC DIAGRAM NOTES.
 2. THE DIAGRAM BELOW SHOWS THE OUTPUT STAGE OF COMPARATOR ASU4 IN DETAIL.

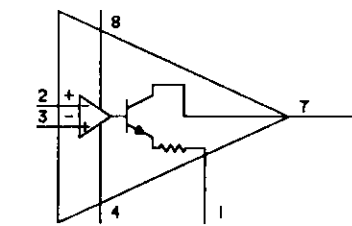

3. PULSE TIMING FOR MONOSTABLE MULTIVIBRATOR ASU9 (SHOWN BELOW) IS AS FOLLOWS:
 Q7 OFF: $t_1 = 13ms$, $t_2 = 9.4ms$
 Q7 ON: $t_1 = 106ms$, $t_2 = 2.4ms$

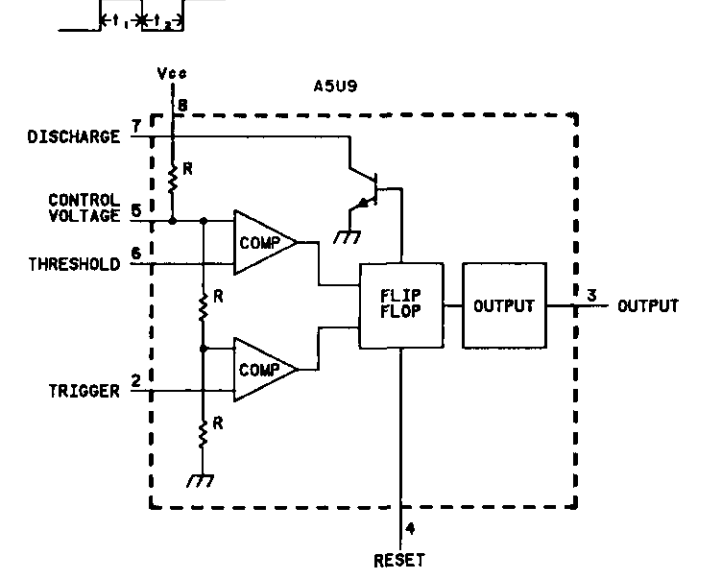

DIGITAL INTEGRATED CIRCUIT VOLTAGE AND GROUND CONNECTIONS

REFERENCE DESIGNATIONS	VOLTAGE	PIN NUMBERS
U15	+5V	5
	∇_2	12
U16	+6V	14
	∇_2	7

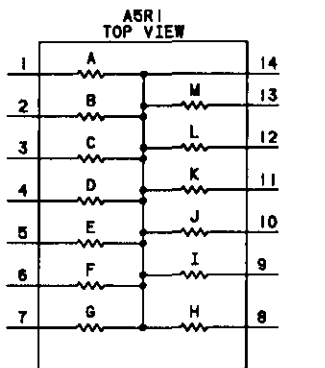

A5 Component Coordinates (2 of 2)

COMP	X,Y	COMP	X,Y	COMP	X,Y	COMP	X,Y
C21	A,2	R65	A,2				
C22	B,2	R66	A,3				
C23	B,2	R67	A,2				
C24	A,2	R68	A,2				
C25	A,2	R69	A,2				
C26	A,2	R70	A,2				
C27	A,2	R71	A,2				
C28	A,2	R72	A,2				
C29	A,2	R73	A,1				
C30	A,2	R74	A,2				
C31	A,2	R75	A,2				
C32	A,2	R76	A,3				
C33	A,2	R77	A,2				
C34	A,2	R78	A,1				
CR13	A,2	R80	A,2				
CR14	A,2	R81	A,2				
CR15	A,2						
CR16	A,3	U2	A,2				
MP1	B,1	U5	A,2				
U7	A,2	U6	A,2				
U10	A,2	U10	A,2				
U11	A,2	U11	A,2				
U12	B,3	U12	A,2				
U13	B,2	U13	B,2				
U14	A,2	U14	B,2				
U17	B,2	U17	B,2				
U18	B,3	U18	A,2				
VR3	A,2	VR3	A,2				
VR4	A,2	VR4	A,2				
R51	A,2	R51	A,2				
R52	A,2	R51	A,2				
R53	A,2	R52	A,2				
R54	A,2	R53	A,2				
R55	A,2	R54	A,2				
R56	A,2	R55	A,2				
R57	A,2	R56	A,2				
R58	A,2	R57	A,2				
R59	A,2	R58	A,2				
R60	A,2	R59	A,2				
R61	A,2	R60	A,2				
R62	A,2	R61	A,2				
R63	A,2	R62	A,2				
R64	A,2	R63	A,2				

SS 14
A5 VOLT METER (1 OF 2)
AUDIO DETECTORS

SEE REVERSE SIDE

Component Locator

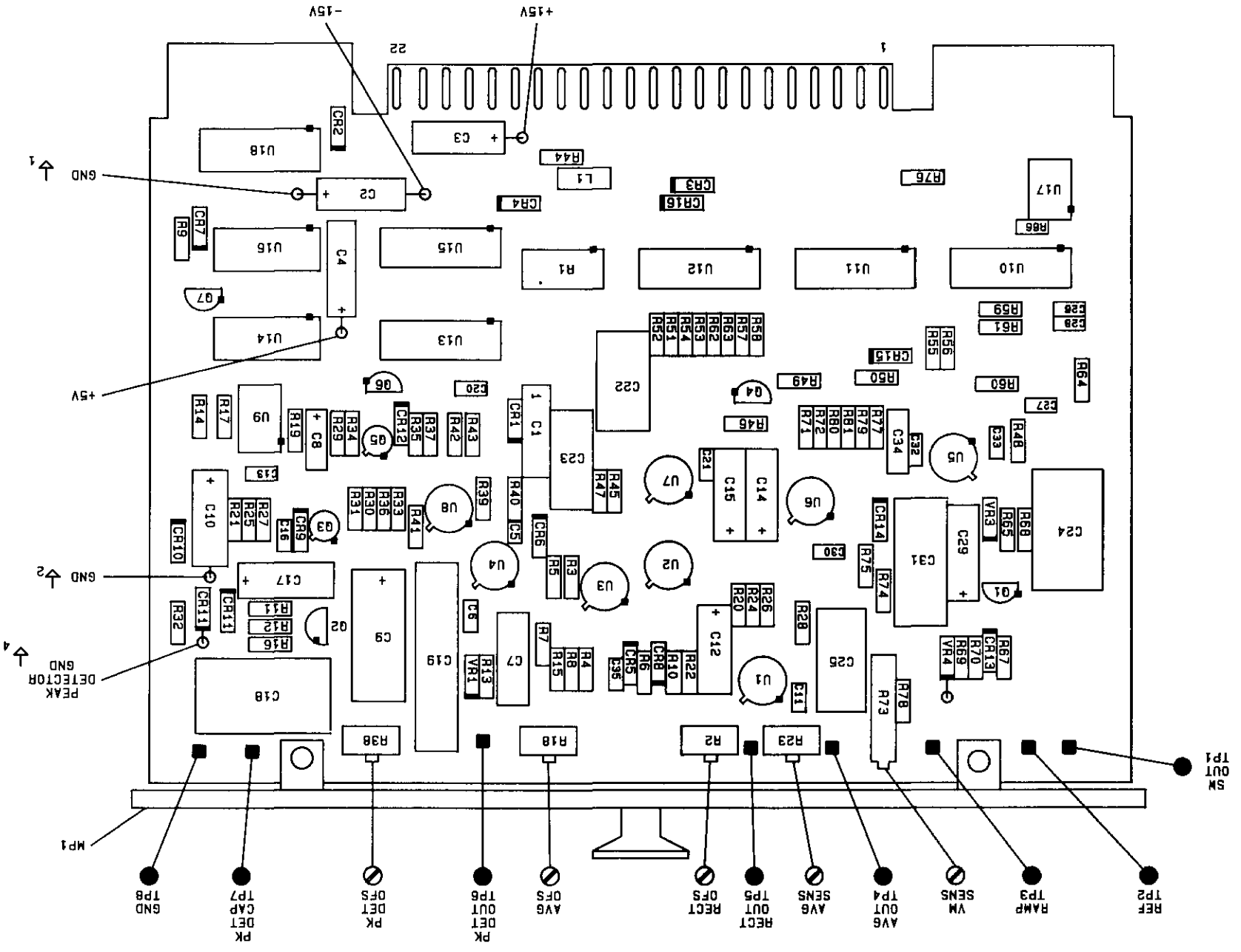

P/O A25
AUDIO MOTHERBOARD
ASSEMBLY (08901-60137)

P/O A5 VOLTMETER ASSEMBLY (2 OF 2) (08902-60005)

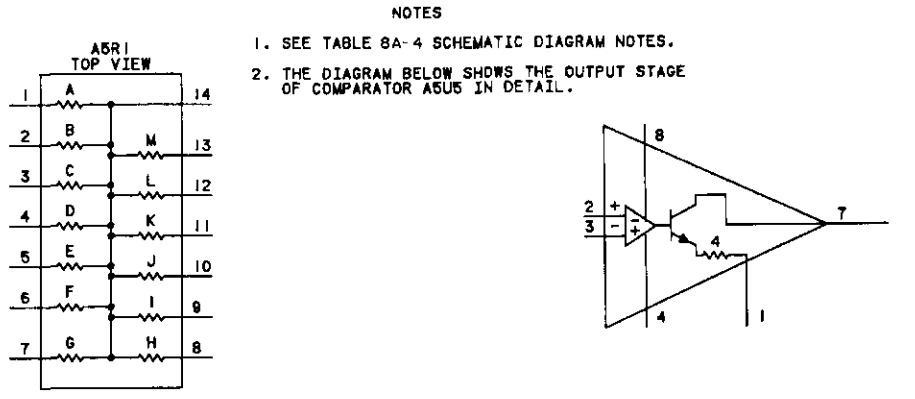
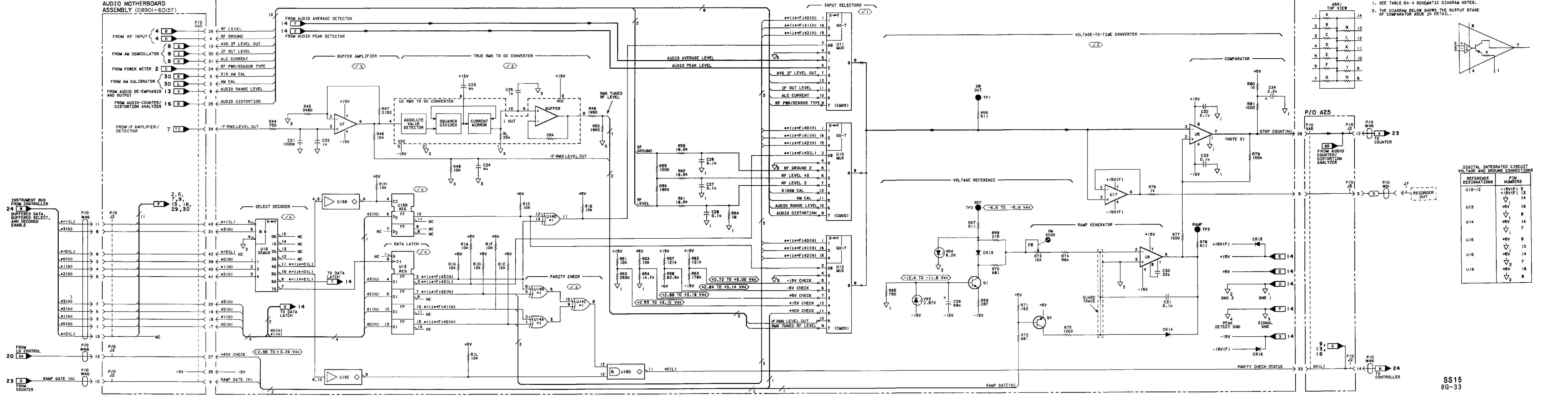

- NOTES
1. SEE TABLE 8A-4 SCHEMATIC DIAGRAM NOTES.
 2. THE DIAGRAM BELOW SHOWS THE OUTPUT STAGE OF COMPARATOR ASR1 IN DETAIL.

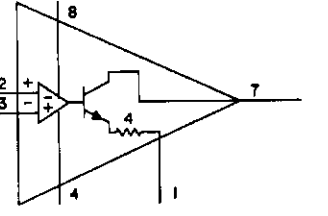

DIGITAL INTEGRATED CIRCUIT
REFERENCE VOLTAGE AND GROUND CONNECTIONS

REFERENCE DESIGNATIONS	PIN NUMBERS
U10-12	-15V(F) 3
	+15V(F) 14
U13	+5V 16
U14	+5V 8
U15	+5V 14
U16	+5V 5
	+5V 12
	+5V 14
	+5V 7
	+5V 16
	+5V 8

A52 Component Coordinates

COMP	X,Y	COMP	X,Y	COMP	X,Y	COMP	X,Y	COMP	X,Y
C1	B,3	CR1	B,1	R35	A,2	U14	B,2		
C2	B,2	CR2	B,1	R36	A,2	U15	B,2		
C3	B,2	CR4	A,1	R37	A,1	U16	A,1		
C4	A,2	CR5	A,2	R38	A,1	U17	A,2		
C5	B,1	CR6	A,1	R39	A,1	U18	B,2		
C6	B,2	CR7	A,2	R40	A,1	U19	B,2		
C7	A,2	CR8	A,2	R41	A,2				
C8	A,2			R42	A,2	VR1	B,2		
C9	B,1	J1	B,1	R43	A,1	VR2	B,2		
C10	A,1	J2	B,1	R44	A,1				
C11	B,1			R45	A,1	W 1	B,2		
C12	B,1	L1	B,3	R46	A,1	W 2	A,2		
C13	B,1	L2	B,2	R47	A,1				
C14	B,2	L3	B,2	R48	A,1				
C15	B,2			R49	A,2				
C16	B,2	R1	B,3	R50	A,2				
C17	B,2	R2	B,3	R51	A,2				
C18	B,2	R3	B,1	R52	A,1				
C19	A,2	R4	B,1	R53	A,2				
C20	A,2	R5	B,2	R54	A,1				
C21	A,2	R6	B,1	R55	B,1				
C22	B,2	R7	A,2	R56	B,1				
C23	B,2	R8	B,1	R57	B,2				
C24	B,2	R9	B,2	R58	B,1				
C25	B,2	R10	B,2	R59	B,1				
C26	A,2	R11	B,2	R60	B,1				
C27	A,2	R12	B,2						
C28	A,2	R13	B,2	TP1	A,1				
C29	A,2	R14	B,2	TP2	A,1				
C30	A,2	R16	B,1	TP3	A,1				
C31	A,1	R17	B,2	TP4	B,1				
C32	A,2	R18	B,2	TP5	B,1				
C33	A,2	R20	B,2						
C34	A,2	R22	B,2	U1	A,1				
C35	A,2	R23	B,2	U2	A,1				
C36	A,2	R24	B,2	U3	B,2				
C37	A,2	R25	B,2	U4	A,2				
C38	A,2	R26	B,2	U5	B,2				
C40	A,2	R27	A,2	U6	A,2				
C41	B,2	R28	B,2	U7	B,2				
C42	B,1	R29	A,2	U8	A,2				
C43	B,1	R30	A,2	U9	A,2				
C44	B,2	R31	A,2	U10	A,2				
C45	B,1	R32	A,2	U11	A,2				
C46	B,2	R33	A,2	U12	A,2				
C47	B,2	R34	A,2	U13	A,2				

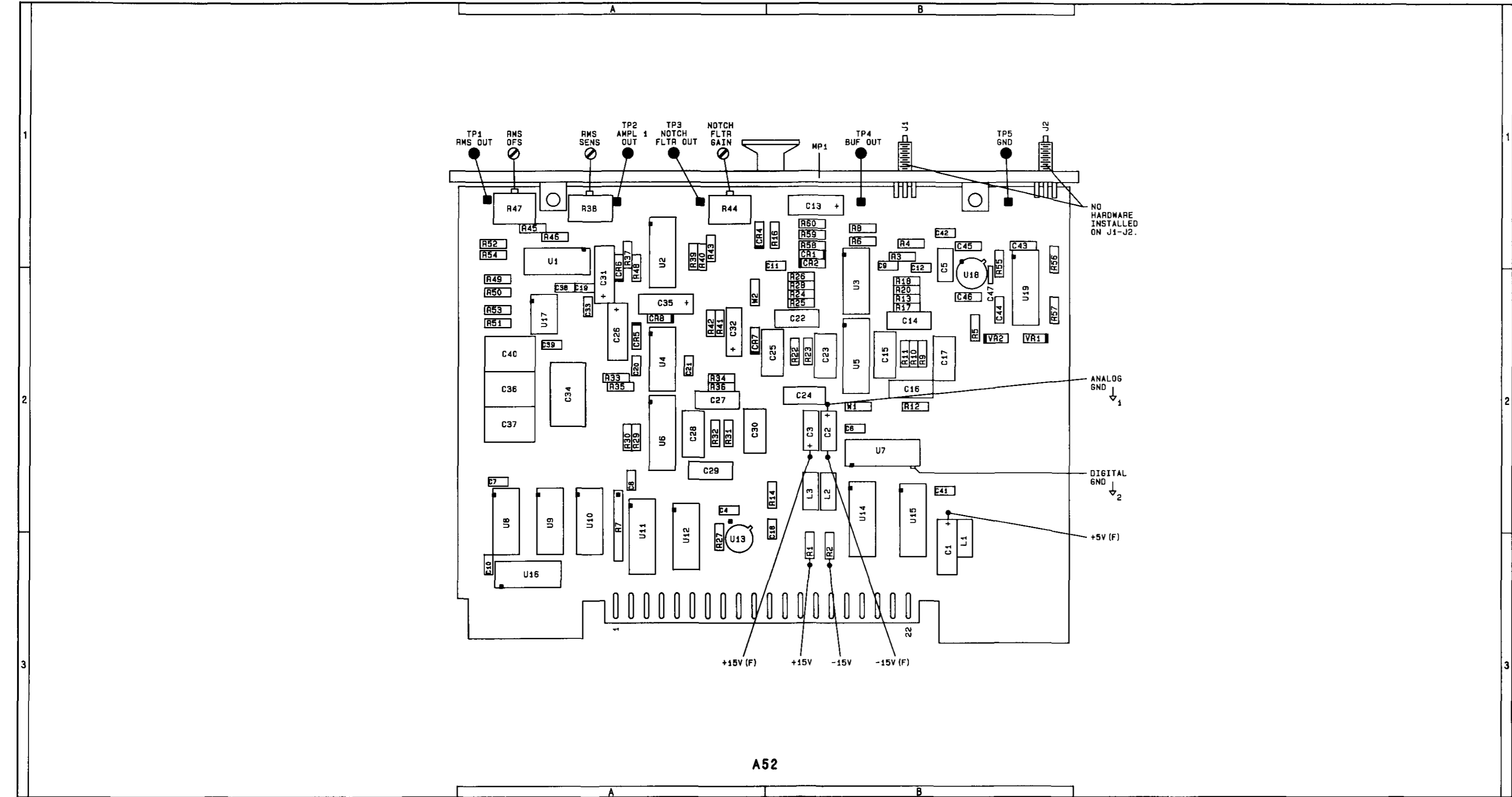

A52
Component Locator

A5 VOLT METER (2 OF 2)
VOLT METER CIRCUITS
SS 15
SEE REVERSE SIDE

A52 AUDIO COUNTER/DISTORTION ANALYZER ASSEMBLY (08901-60131)

P/O A25 AUDIO MOTHERBOARD ASSEMBLY (08901-60137)

(OPTION 001 ONLY)
MODULATION OUTPUT/AUDIO INPUT

(EXCEPT OPTION 001)
MODULATION OUTPUT/AUDIO INPUT

BUFFERED DATA BUFFERED SELECT/DECODED ENABLE

INSTRUMENT BUS FROM CONTROLLER

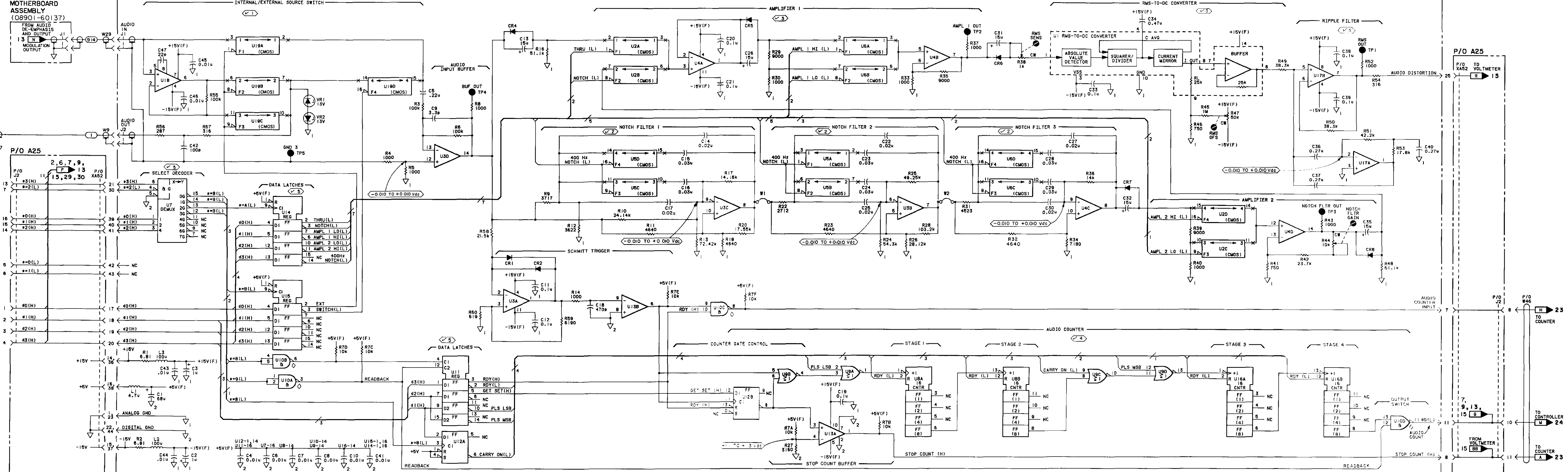

NOTES
1. SEE TABLE BA-4 SCHEMATIC DIAGRAM NOTES.

DIGITAL INTEGRATED CIRCUIT VOLTAGE AND GROUND CONNECTIONS

REFERENCE DESIGNATIONS	VOLTAGE	PIN NUMBERS
U2, 5, 6, 19	+15V(F)	13
	-15V(F)	4
U7, 11, 14, 15	+5V(F)	16
	-5V(F)	8
U8, 9, 10, 12, 16	+5V(F)	14
	-5V(F)	7

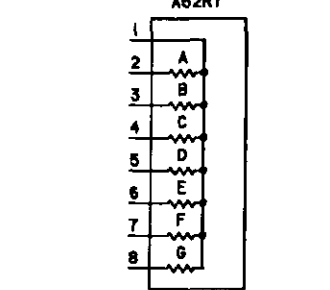

SERIAL PREFIX: 2305A

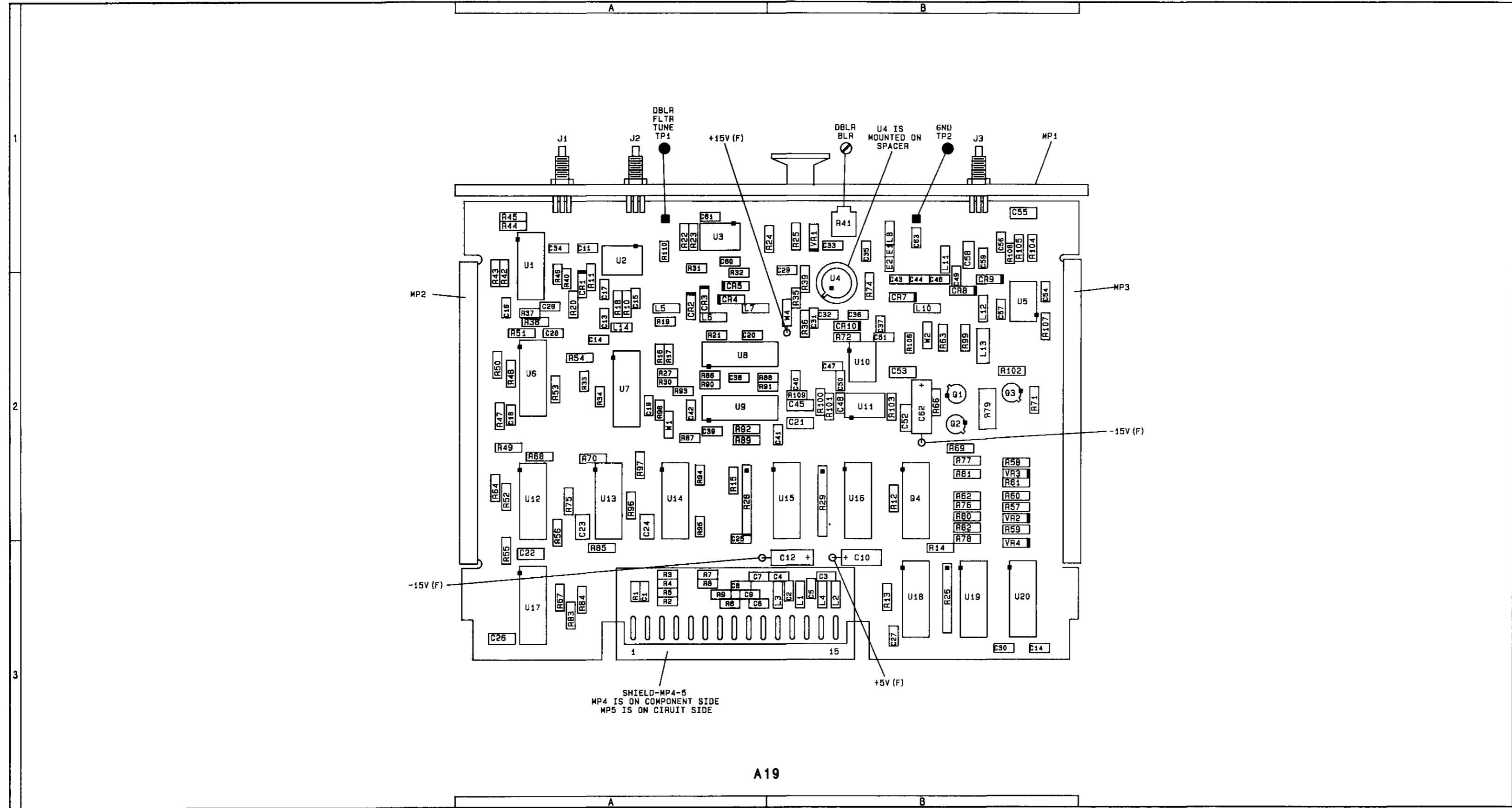

Component Locator

COMP	X,Y	COMP	X,Y	COMP	X,Y	COMP	X,Y	COMP	X,Y	COMP	X,Y
C1	A,3	C46	B,2	L11	B,1	R32	A,2	R80	B,2	U11	B,2
C2	B,3	C47	B,2	L12	B,2	R33	A,2	R81	B,2	U12	A,2
C3	B,3	C48	B,2	L13	B,2	R34	A,2	R82	B,2	U13	A,2
C4	B,3	C49	B,2	L14	A,2	R35	B,2	R83	A,3	U14	A,2
C5	B,3	C50	B,2			R36	B,2	R84	A,3	U15	B,2
C6	A,3	C51	B,2	MP1	B,1	R37	A,2	R85	A,3	U16	B,2
C7	A,3	C52	B,2	MP2	A,2	R38	A,2	R86	A,2	U17	A,3
C8	A,3	C53	B,2	MP3	B,2	R39	B,2	R87	A,2	U18	B,3
C9	A,3	C54	B,2			R40	A,2	R88	A,2	U19	B,3
C10	B,3	C55	B,1	Q1	B,2	R41	B,1	R89	A,2	U20	B,3
C11	A,1	C56	B,1	Q2	B,2	R42	A,2	R90	A,2		
C12	B,3	C57	B,2	Q3	B,2	R43	A,2	R91	A,2	VR1	B,1
C13	A,2	C58	B,1	Q4	B,2	R44	A,1	R92	A,2	VR2	B,2
C14	B,3	C59	B,1			R45	A,1	R93	A,2	VR3	B,2
C15	A,2	C60	A,1	R1	A,3	R46	A,2	R94	A,2	VR4	B,2
C16	A,2	C61	A,1	R2	A,3	R47	A,2	R95	A,2		
C17	A,2	C62	B,2	R3	A,3	R48	A,2	R96	A,2	W1	A,2
C18	A,2	C63	B,1	R4	A,3	R49	A,2	R97	A,2	W2	B,2
C19	A,2			R5	A,3	R50	A,2	R98	A,2	W4	B,2
C20	A,2	CR1	A,2	R6	A,3	R51	A,2	R99	B,2		
C21	B,2	CR2	A,2	R7	A,3	R52	A,2	R100	B,2		
C22	A,3	CR3	A,2	R8	A,3	R53	A,2	R101	B,2		
C23	A,2	CR4	A,2	R9	A,3	R54	A,2	R102	B,2		
C24	A,2	CR5	A,2	R10	A,2	R55	A,3	R103	B,2		
C25	A,2	CR7	B,2	R11	A,2	R56	A,2	R104	B,1		
C26	A,3	CR8	B,2	R12	B,2	R57	B,2	R105	B,1		
C27	B,3	CR9	B,2	R13	B,3	R58	B,2	R106	B,2		
C28	A,2	CR10	B,2	R14	B,3	R59	B,2	F107	B,2		
C29	B,1			R15	A,2	R61	B,2	R108	B,1		
C30	B,3	E1	B,1	R16	A,2	R62	B,2	R109	B,2		
C31	B,2	E2	B,1	R17	A,2	R63	B,2	R110	A,1		
C32	B,2			R18	A,2	R64	A,2				
C33	B,1	J1	A,1	R19	A,2	R66	B,2	TP1	A,1		
C34	A,1	J2	A,1	R20	A,2	R67	A,3	TP2	B,1		
C35	B,1	J3	B,1	R21	A,2	R68	A,2				
C36	B,2			R22	A,1	R69	B,2	U1	A,1		
C37	B,2	L1	B,3	R23	A,1	R70	A,2	U2	A,1		
C38	A,2	L2	B,3	R24	B,1	R71	B,2	U3	A,1		
C39	A,2	L3	D,3	R25	B,1	R72	B,2	U4	B,2		
C40	B,2	L4	B,3	R26	B,3	R74	B,2	U5	B,2		
C41	B,2	L5	A,2	R27	A,2	R75	A,2	U6	A,2		
C42	A,2	L6	A,2	R28	A,2	R76	B,2	U7	A,2		
C43	B,2	L7	A,2	R29	B,2	R77	B,2	U8	A,2		
C44	B,2	L8	B,1	R30	A,2	R78	B,2	U9	A,2		
C45	B,2	L10	B,2	R31	A,1	R79	B,2	U10	B,2		

A52 AUDIO COUNTER/
DISTORTION ANALYZER **SS16**
SEE REVERSE SIDE

CHANGES

<p>All serial prefixes</p>	<p>On the A19 schematic:</p> <ul style="list-style-type: none"> • W34, W54 - Add W34 and W54 as shown in the figure P/O A19 LO Divider Assembly on page 8G-36.3. • R34 - On the partial schematic, page 8G-36.5, change the value of R34 to 750 ohm. • Delete the page number (8G-37) and replace it with a revision date of <i>rev.01MAY88</i>. 								
<p>2406A to 2806A</p>	<p>On the A19 schematic:</p> <ul style="list-style-type: none"> • C38, R21, R27, R86 - Make the following value changes: <table style="margin-left: 40px;"> <tr> <td>C38</td> <td>100p</td> </tr> <tr> <td>R21</td> <td>121</td> </tr> <tr> <td>R27</td> <td>51.1</td> </tr> <tr> <td>R86</td> <td>51.1</td> </tr> </table>	C38	100p	R21	121	R27	51.1	R86	51.1
C38	100p								
R21	121								
R27	51.1								
R86	51.1								
<p>2622A to 2806A</p>	<p>On the A19 Component Locator:</p> <ul style="list-style-type: none"> • 08901-60274 - Use the A19 LO Divider Assembly Component Locations (2622A) on page 8G-36.4. <p>On the A19 schematic:</p> <ul style="list-style-type: none"> • 08901-60274 - Change the part number of the A19 LO Divider Assembly to 08901-60274. • Modify the appropriate portions of the schematic as shown in the partial schematics P/O A19 LO Divider Assembly (2622A) on pages 8G-36.5 and 8G-36.6. See "All serial prefixes" for a value change on R33 and R34. 								

Reserved for future changes.

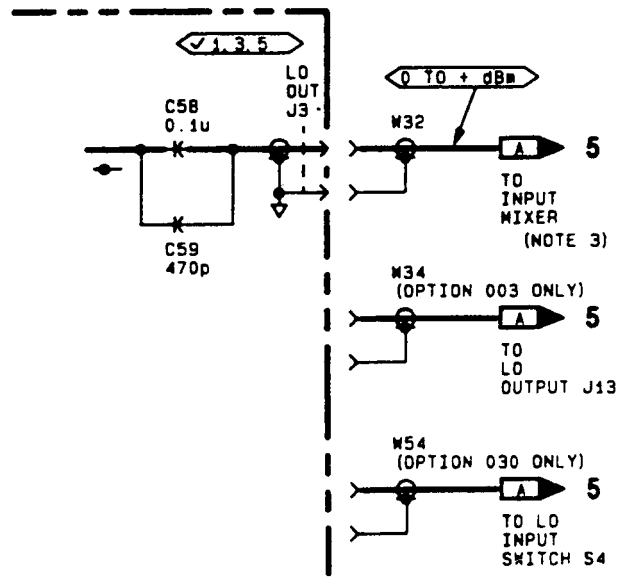

P/O SS17 A19 LO Divider Assembly (Errata)

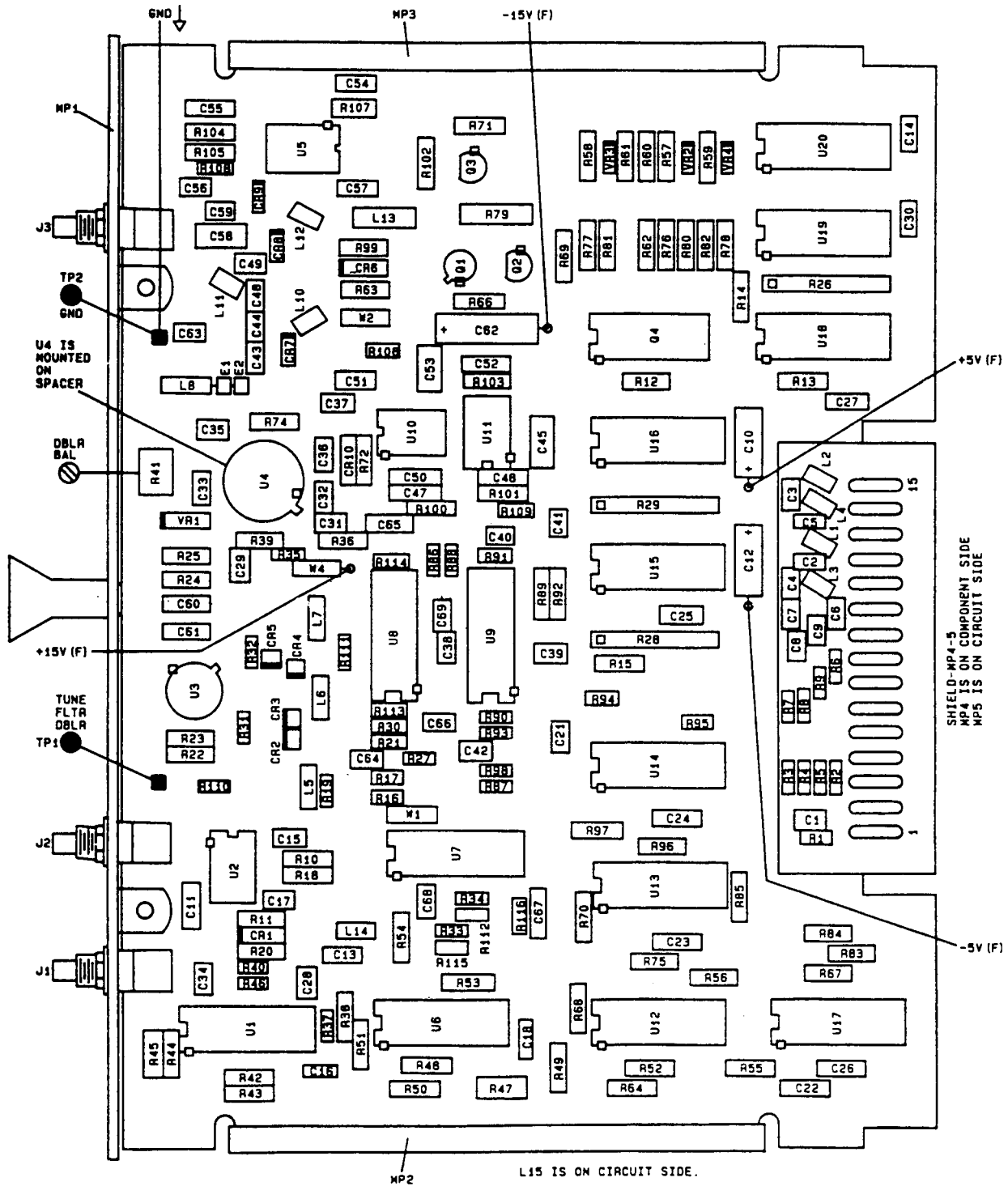

P/O A19 Component Locator for the 08902-60274 board, (2622A to 2806A)

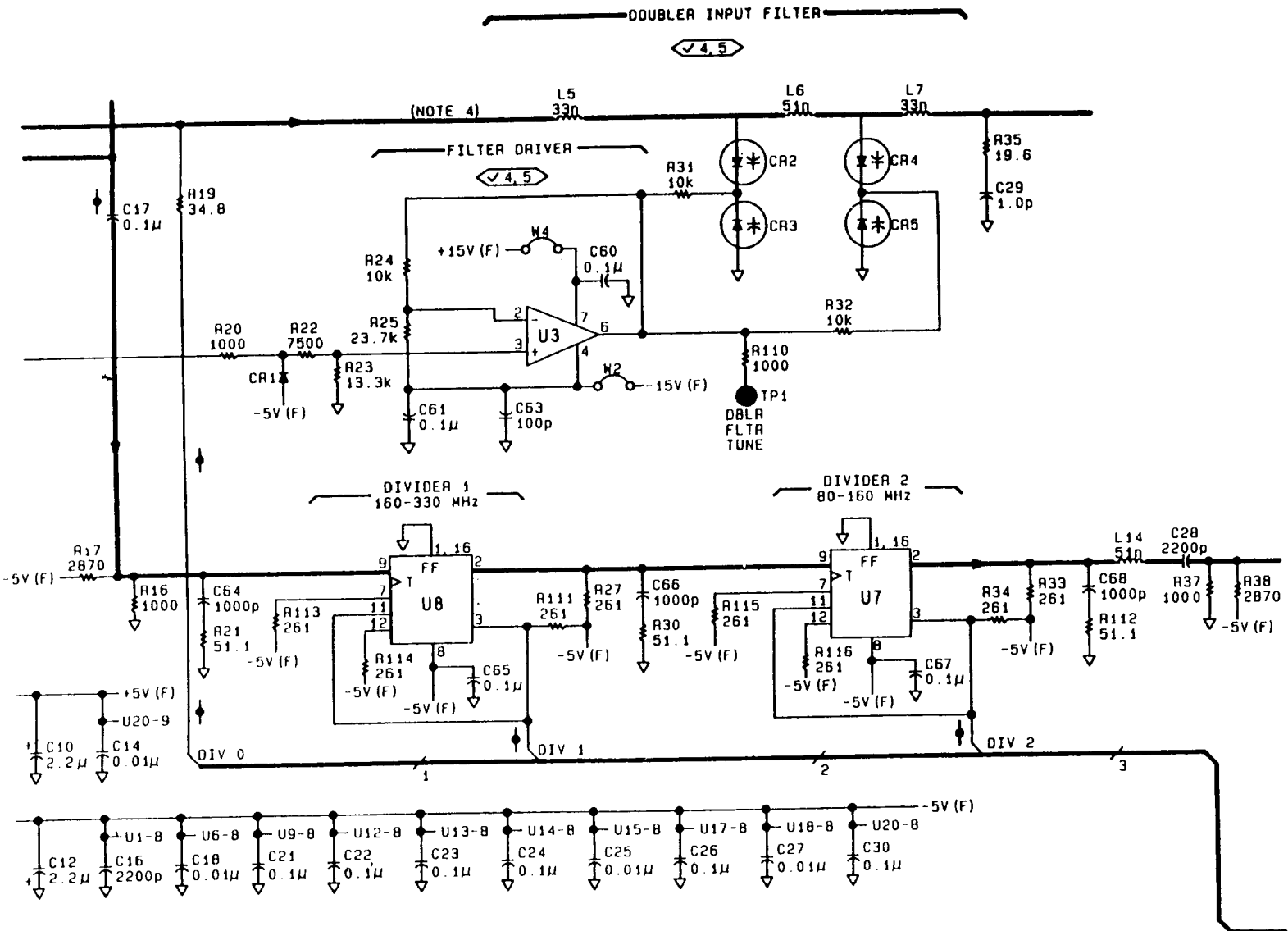

P/O A19 LO Divider Assembly for the 08902-60274 board, (2622A to 2806A)

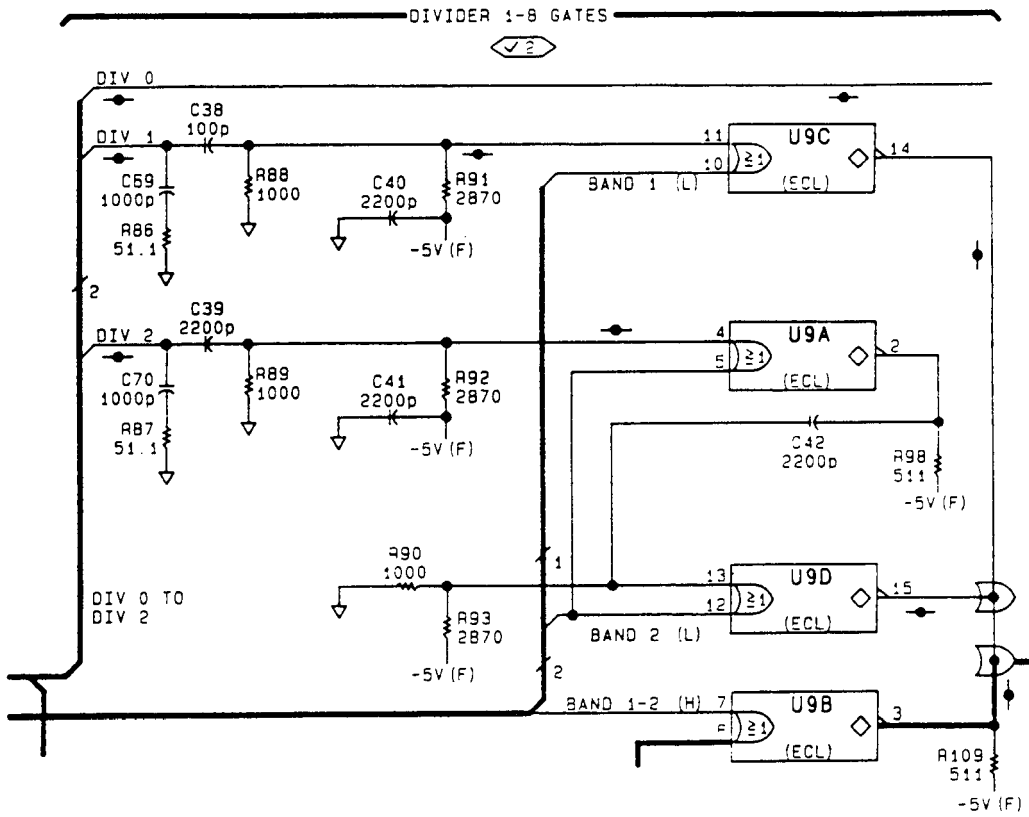

P/O A19 LO Divider Assembly (2622A to 2806A)

CHANGES

2909A and above	<p>On the A19 schematic:</p> <ul style="list-style-type: none">• A19 - Use SS17A with the revision date of <i>rev.01APR89</i>. <p>On the A19 Component Locator:</p> <ul style="list-style-type: none">• A19 - Use the new A19 component locator on page 8G-36.9. <p>On the A19 Component Coordinates:</p> <ul style="list-style-type: none">• A19 - Use the new A19 (SS17A) component coordinates on page 8G-36.10.

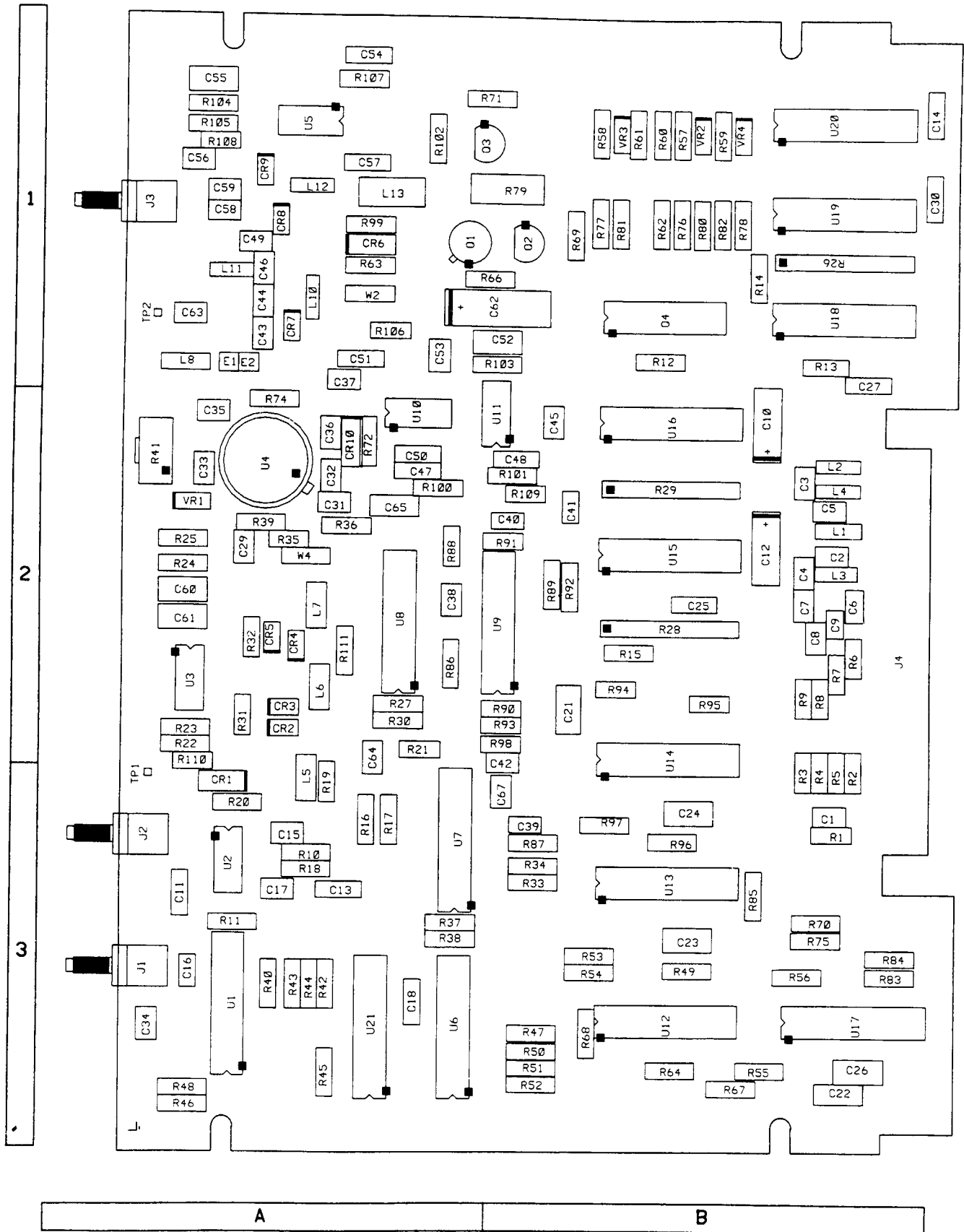

A19 Component Locator for the 08902-60126 board, (2909A and above)

A19 Component Coordinates (2742A and Above)

COMP	X,Y	COMP	X,Y	COMP	X,Y	COMP	X,Y	COMP	X,Y
C1	B,3	C58	A,1	R18	A,3	R83	B,3		
C2	B,2	C59	A,1	R19	A,3	R84	B,3		
C3	B,2	C60	A,2	R20	A,3	R85	B,3		
C4	B,2	C61	A,2	R21	A,2	R86	A,2		
C5	B,2	C62	A,1	R22	A,2	R87	B,3		
C10	B,2	C63	A,1	R23	A,2	R99	A,1		
C11	A,3	C64	A,2	R24	A,2	R100	A,2		
C12	B,2	C65	A,2	R25	A,2	R101	A,2		
C13	A,3	C67	A,3	R27	A,2	R102	A,1		
C14	B,1			R30	A,2	R103	A,1		
C15	A,3	CR1	A,3	R31	A,2	R104	A,1		
C16	A,3	CR2	A,2	R32	A,2	R105	A,1		
C17	A,3	CR3	A,2	R33	B,3	R106	A,1		
C18	A,3	CR4	A,2	R34	B,3	R107	A,1		
C21	B,2	CR5	A,2	R35	A,2	R108	A,1		
C22	B,3	CR7	A,1	R36	A,2	R110	A,2		
C23	B,3	CR8	A,1	R37	A,3	R111	A,2		
C24	B,3	CR9	A,1	R38	A,3				
C25	B,2	CR10	A,2	R39	A,2	TP1	A,3		
C26	B,3			R40	A,3				
C27	B,1	E1	A,1	R41	A,2	U1	A,3		
C29	A,2	E2	A,1	R42	A,3	U2	A,3		
C30	B,1			R43	A,3	U3	A,2		
C31	A,2	J1	A,3	R44	A,3	U4	A,2		
C32	A,2	J2	A,3	R45	A,3	U5	A,1		
C33	A,2	J3	A,1	R46	A,3	U6	A,3		
C34	A,3			R47	B,3	U7	A,3		
C35	A,2	L1	B,2	R48	A,3	U8	A,2		
C36	A,2	L2	B,2	R49	B,3	U10	A,2		
C37	A,1	L3	B,2	R49	B,3	U11	A,2		
C43	A,1	L4	B,2	R50	B,3	U12	B,3		
C44	A,1	L5	A,3	R51	B,3	U17	B,3		
C45	B,2	L6	A,2	R52	B,3	U21	A,3		
C46	A,1	L7	A,2	R53	B,3				
C47	A,2	L8	A,1	R54	B,3	VR1	A,2		
C48	A,2	L10	A,1	R55	B,3				
C49	A,1	L11	A,1	R56	B,3	W 2	A,1		
C50	A,2	L12	A,1	R63	A,1	W 4	A,2		
C51	A,1	L13	A,1	R64	B,3				
C52	A,1			R67	B,3				
C53	A,1	R1	B,3	R68	B,3				
C54	A,1	R10	A,3	R70	B,3				
C55	A,1	R11	A,3	R72	A,2				
C56	A,1	R16	A,3	R74	A,2				
C57	A,1	R17	A,3	R75	B,3				

A19 Component Coordinates for the 08902-60126 board, (2909A and above)

Reserved for future changes.

Reserved for future changes.

A19 LO DIVIDER ASSEMBLY (08902-60126)

08901-90114

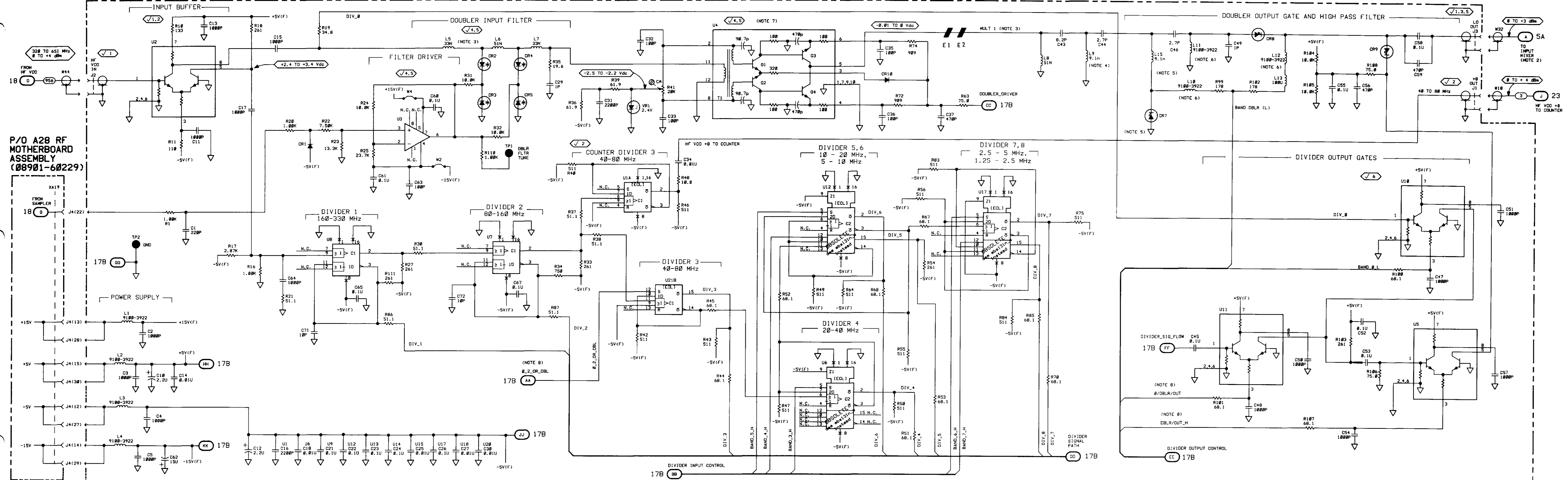

SS17A

rev. 01 APR 89

Serial Prefix 24004 or 1A

CHANGES

<p>2909A and above</p>	<p>On the A19 schematic:</p> <ul style="list-style-type: none">• A19 - Use SS17B with the revision date of <i>rev.01APR89</i>. <p>On the A19 Component Locator:</p> <ul style="list-style-type: none">• A19 - Use the new A19 component locator for SS17B on page 8G-36.15. <p>On the A19 Component Coordinates:</p> <ul style="list-style-type: none">• A19 - Use the new A19 component coordinates for SS17B on page 8G-36.16.

Reserved for future changes.

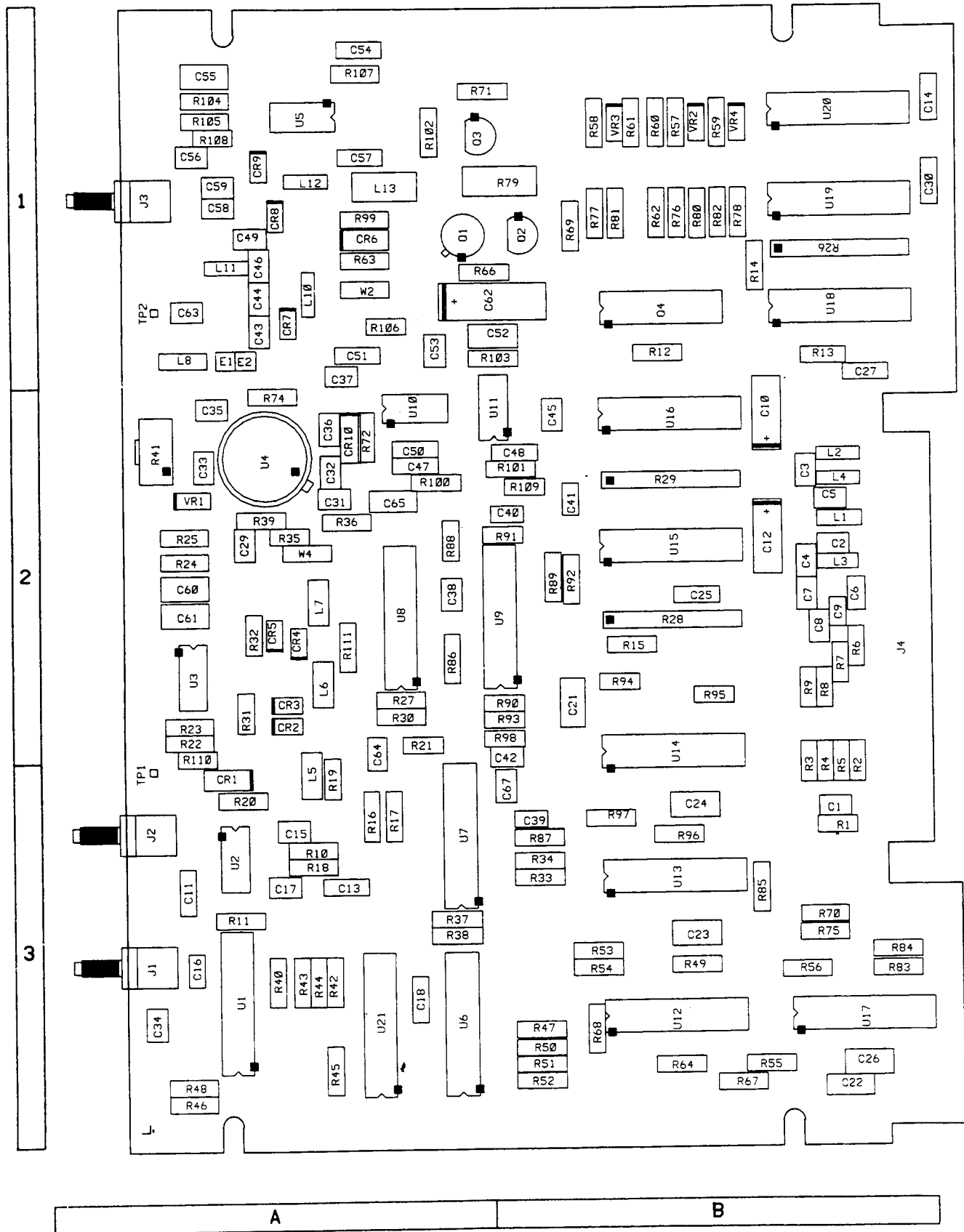

A19 Component Locator for the 08902-60126 board, (2909A and above)

SS17B

8G-36.15

A19 Component Coordinates (2742A and Above)

COMP	X,Y	COMP	X,Y	COMP	X,Y	COMP	X,Y	COMP	X,Y
C6	B,2	R78	B,1						
C7	B,2	R79	A,1						
C8	B,2	R80	B,1						
C9	B,2	R81	B,1						
C38	A,2	R82	B,1						
C39	B,3	R88	A,2						
C40	A,2	R89	B,2						
C41	B,2	R90	A,2						
C42	A,2	R91	A,2						
		R92	B,2						
CR6	A,1	R93	A,2						
		R94	B,2						
J4	B,2	R95	B,2						
		R96	B,3						
Q1	A,1	R97	B,3						
Q2	B,1	R98	A,2						
Q3	A,1	R109	B,2						
Q4	A,1								
Q12	B,1	TP2	A,1						
R2	B,3	U9	A,2						
R3	B,3	U13	B,3						
R4	B,3	U14	B,2						
R5	B,3	U15	B,2						
R6	B,2	U16	B,2						
R7	B,2	U18	B,1						
R8	B,2	U19	B,1						
R9	B,2	U20	B,1						
R13	B,1								
R14	B,1	VR2	B,1						
R15	B,2								
R26	B,1								
R28	B,2								
R29	B,2								
R57	B,1								
R58	B,1								
R59	B,1								
R60	B,1								
R61	B,1								
R62	B,1								
R66	A,1								
R69	B,1								
R71	A,1								
R76	B,1								
R77	B,1								

A19 Component Coordinates for the 08902-60126 board, (2909A and above)

A19 LO DIVIDER ASSEMBLY (08902-60126)

P/O A28 RF MOTHERBOARD ASSEMBLY (08901-60229)

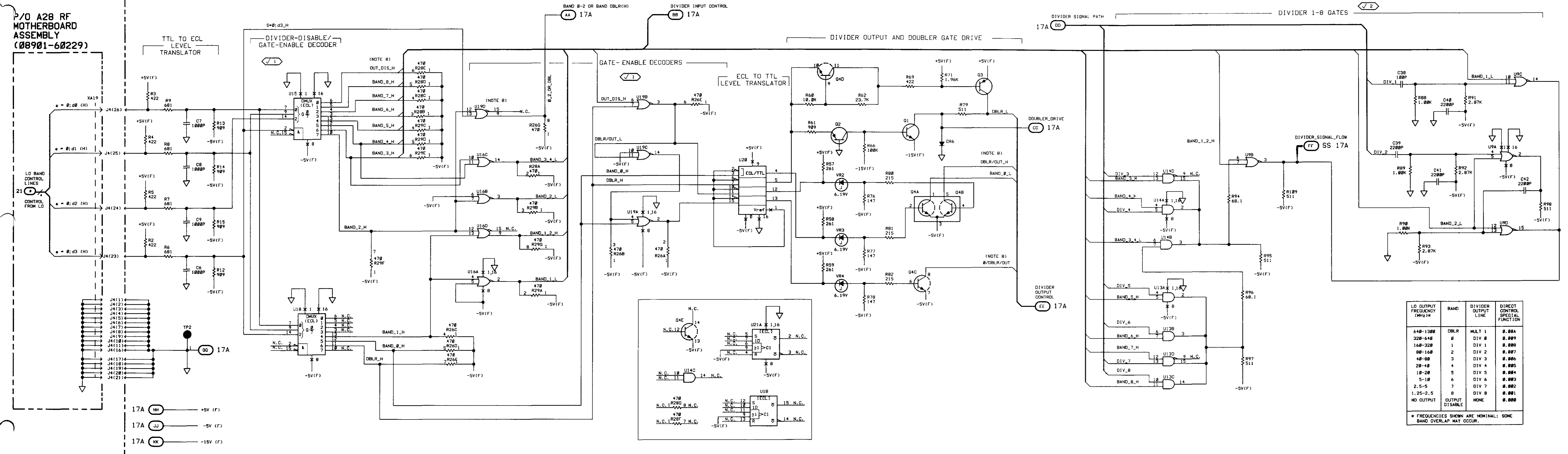

LO OUTPUT FREQUENCY (MHz)*	BAND	DIVIDER OUTPUT LINE	DIRECT CONTROL SPECIAL FUNCTION
640-1300	DBLR	MULT 1	0.00A
320-640	0	DIV 0	0.009
160-320	1	DIV 1	0.008
80-160	2	DIV 2	0.007
40-80	3	DIV 3	0.006
20-40	4	DIV 4	0.005
10-20	5	DIV 5	0.004
5-10	6	DIV 6	0.003
2.5-5	7	DIV 7	0.002
1.25-2.5	8	DIV 8	0.001
NO OUTPUT	OUTPUT DISABLE	NONE	0.000

* FREQUENCIES SHOWN ARE NOMINAL; SOME BAND OVERLAP MAY OCCUR.

A19 LO DIVIDER ASSEMBLY (08901-60024)

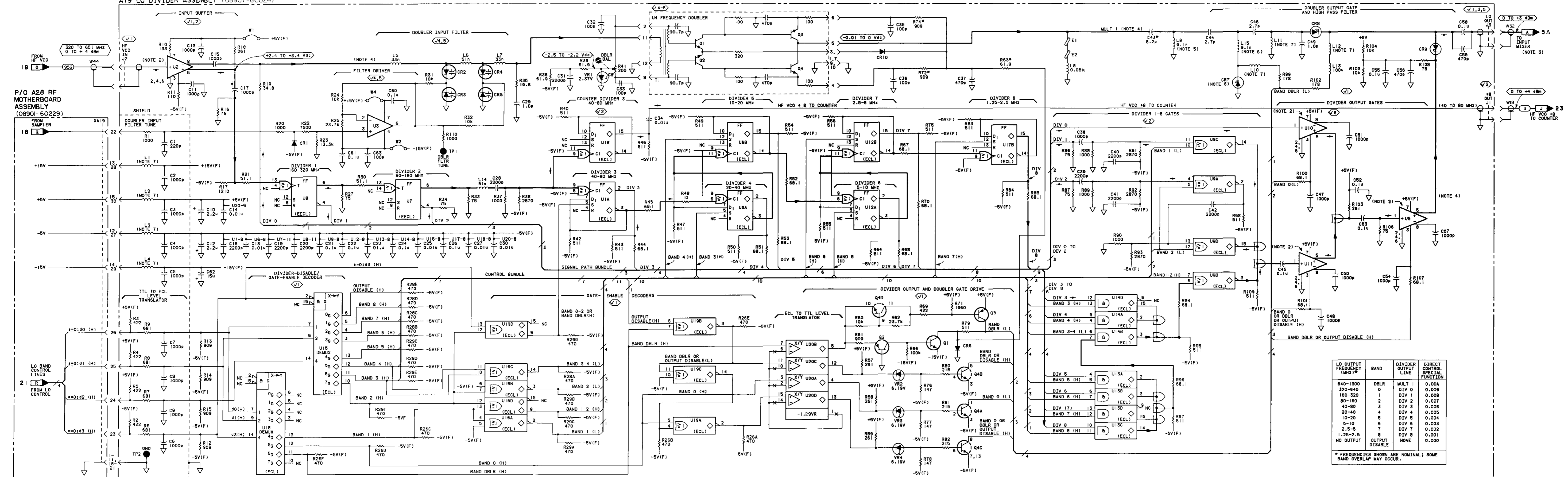

- NOTES
1. SEE TABLE 8A-4 SCHEMATIC DIAGRAM NOTES.
 2. SHOWN BELOW IS A SCHEMATIC OF A19U2, 6, 10 AND 11.
 3. SEE SERVICE SHEET 5 FOR CABLE COLOR AND REFERENCE DESIGNATOR.
 4. MAIN SIGNAL FLOW IS SHOWN FOR OUTPUTS OF 640-1300 MHz (DBLR BAND) AND 1.25-2.5 MHz (BAND 8). IN ACTUAL OPERATION ONLY ONE OF THE TEN BANDS IS OUTPUT.
 5. L9 IS A PC TRACE.
 6. THE INDUCTANCE IS A COMBINATION OF PC TRACE, DIODE LEAD, AND DIODE INDUCTANCE AND EQUALS ≈ 0.1 nH.
 7. INDUCTANCE IS APPROXIMATELY 4.5 nH AT 1 MHz.

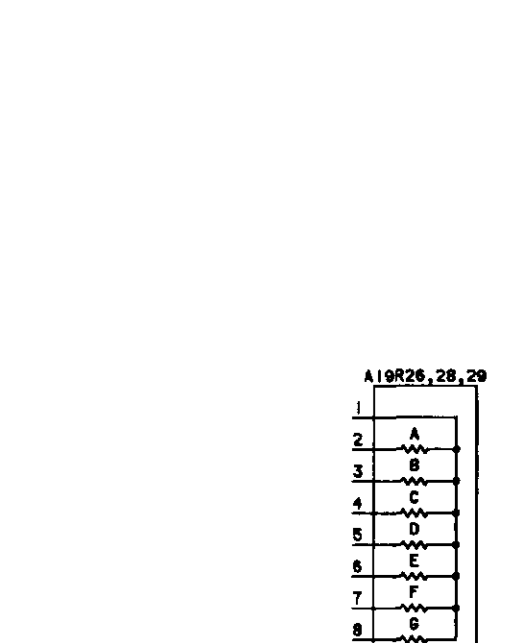

LO OUTPUT FREQUENCY (MHz)*	BAND	DIVIDER OUTPUT LINE	DIRECT CONTROL SPECIAL FUNCTION
640-1300	DBLR	MULT 1	0.00A
320-640	0	DIV 0	0.009
160-320	1	DIV 1	0.008
80-160	2	DIV 2	0.007
40-80	3	DIV 3	0.006
20-40	4	DIV 4	0.005
10-20	5	DIV 5	0.004
5-10	6	DIV 6	0.003
2.5-5	7	DIV 7	0.002
1.25-2.5	8	DIV 8	0.001
NO OUTPUT	OUTPUT DISABLE	NONE	0.000

* FREQUENCIES SHOWN ARE NOMINAL; SOME BAND OVERLAP MAY OCCUR.

REFERENCE DESIGNATIONS	PIN NUMBERS
U1, 6, 9, 12-19	∇ (F) - 8
	∇ (F) - 1, 16
U7, 8	∇ (F) - 11
	∇ (F) - 16
U20	∇ (F) - 9
	∇ (F) - 8

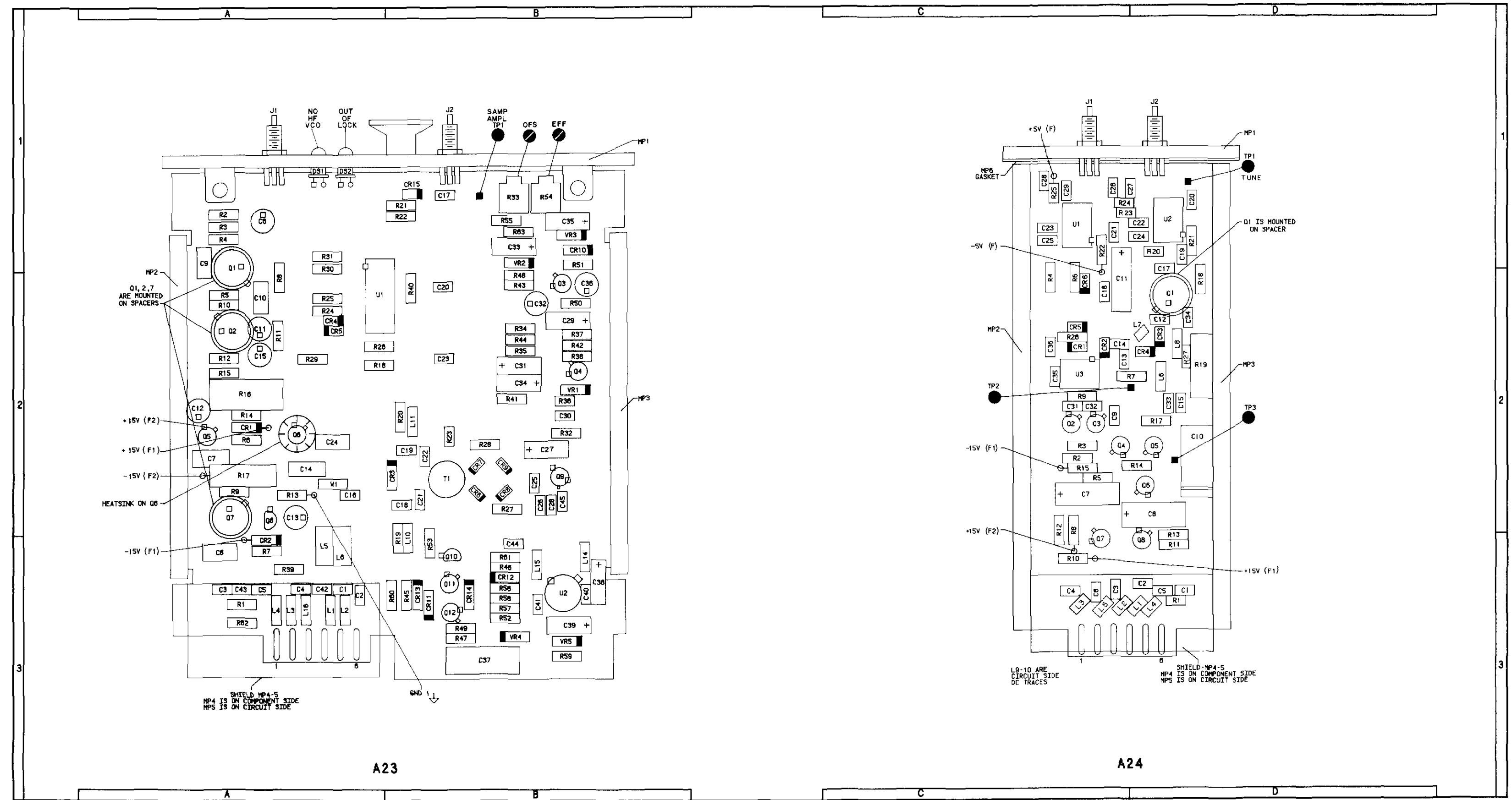

Component Locators

A23 Component Coordinates

COMP	X,Y	COMP	X,Y	COMP	X,Y	COMP	X,Y	COMP	X,Y
C1	A,3	CR2	A,3	Q9	B,2	R43	B,2		
C2	A,3	CR3	B,2	Q10	B,3	R44	B,2		
C3	A,3	CR4	A,2	Q11	B,3	R45	B,3		
C4	A,3	CR5	A,2	Q12	B,3	R46	B,3		
C5	A,3	CR6	B,2			R47	B,3		
C6	A,1	CR7	B,2	R1	A,3	R48	B,2		
C7	A,2	CR8	B,2	R2	A,1	R49	B,3		
C8	A,3	CR9	B,2	R3	A,1	R50	B,2		
C9	A,1	CR10	B,1	R4	A,1	R51	B,1		
C10	A,2	CR11	B,3	R5	A,2	R52	B,3		
C11	A,2	CR12	B,3	R6	A,2	R53	B,3		
C12	A,2	CR13	B,3	R7	A,3	R54	B,1		
C13	A,2	CR14	B,3	R8	A,2	R55	B,1		
C14	A,2	CR15	B,1	R9	A,2	R56	B,3		
C15	A,2			R10	A,2	R57	B,3		
C16	A,2	DS1	A,1	R11	A,2	R58	B,3		
C17	B,1	DS2	A,1	R12	A,2	R59	B,3		
C18	B,2			R13	A,2	R60	B,3		
C19	B,2	J1	A,1	R14	A,2	R61	B,3		
C20	B,2	J2	B,1	R15	A,2	R62	A,3		
C21	B,2			R16	A,2	R63	B,1		
C22	B,2	L1	A,3	R17	A,2				
C23	B,2	L2	A,3	R18	A,2	T1	B,2		
C24	A,2	L3	A,3	R19	B,3	TP1	B,1		
C25	B,2	L4	A,3	R20	B,2				
C26	B,2	L5	A,3	R21	B,1	U1	A,2		
C27	B,2	L6	A,3	R22	B,1	U2	B,3		
C28	B,2	L10	B,3	R23	B,2				
C29	B,2	L11	B,2	R24	A,2	VR1	B,2		
C30	B,2	L14	B,3	R25	A,2	VR2	B,1		
C31	B,2	L15	B,3	R26	A,2	VR3	B,1		
C32	B,2	L16	A,3	R27	B,2	VR4	B,3		
C33	B,1			R28	B,2	VR5	B,3		
C34	B,2	MP1	B,1	R29	A,2				
C35	B,1	MP2	A,2	R30	A,2	W1	A,2		
C36	B,2	MP3	B,2	R31	A,1				
C37	B,3	MP4	A,3	R32	B,2				
C38	B,3	MP5	A,3	R33	B,1				
C39	B,3			R34	B,2				
C40	B,3	Q1	A,2	R35	B,2				
C41	B,3	Q2	A,2	R36	B,2				
C42	A,3	Q3	B,2	R37	B,2				
C43	A,3	Q4	B,2	R38	B,2				
C44	B,3	Q5	A,2	R39	A,3				
C45	B,2	Q6	A,2	R40	B,2				
		Q7	A,2	R41	B,2				
CR1	A,2	Q8	A,2	R42	B,2				

A24 Component Coordinates

COMP	X,Y	COMP	X,Y	COMP	X,Y	COMP	X,Y	COMP	X,Y
C1	D,3	L3	C,3	R26	C,2				
C2	D,3	L4	D,3	R27	D,2				
C3	C,3	L5	C,3						
C4	C,3	L6	D,2	TP1	D,1				
C5	D,3	L7	D,2	TP2	C,2				
C6	C,3	L8	D,2	TP3	D,2				
C7	C,2								
C8	D,2	MP1	D,1	U1	C,1				
C9	C,2	MP2	C,2	U2	D,1				
C10	D,2	MP3	D,2	U3	C,2				
C11	C,2	MP4	D,3						
C12	D,2	MP5	D,3						
C13	C,2	MP6	C,1						
C14	C,2								
C15	D,2	Q1	D,2						
C17	D,2	Q2	C,2						
C18	C,2	Q3	C,2						
C19	D,1	Q4	C,2						
C20	D,1	Q5	D,2						
C21	C,1	Q6	D,2						
C22	D,1	Q7	C,3						
C23	C,1	Q8	D,3						
C24	D,1								
C25	C,1	R1	D,3						
C26	C,1	R2	C,2						
C27	D,1	R3	C,2						
C28	C,1	R4	C,2						
C29	C,1	R5	C,2						
C31	C,2	R6	C,2						
C32	C,2	R7	D,2						
C33	D,2	R8	C,3						
C34	D,2	R9	C,2						
C35	C,2	R10	C,3						
C36	C,2	R11	D,3						
		R12	C,3						
CR1	C,2	R13	D,3						
CR2	C,2	R14	D,2						
CR3	D,2	R15	C,2						
CR4	D,2	R17	D,2						
CR5	C,2	R18	D,2						
CR6	C,2	R19	D,2						
		R20	D,1						
J1	C,1	R21	D,1						
J2	D,1	R22	C,1						
		R23	D,1						
L1	D,3	R24	C,1						
L2	C,3	R25	C,1						

SEE REVERSE SIDE **A19 LO DIVIDER SS17**

CHANGES

<p>All serial prefixes</p>	<p>On the A23 schematic:</p> <ul style="list-style-type: none">• <u>R4</u> - Under SAMPLER AMPLIFIER change the reference designator R4 to R54.

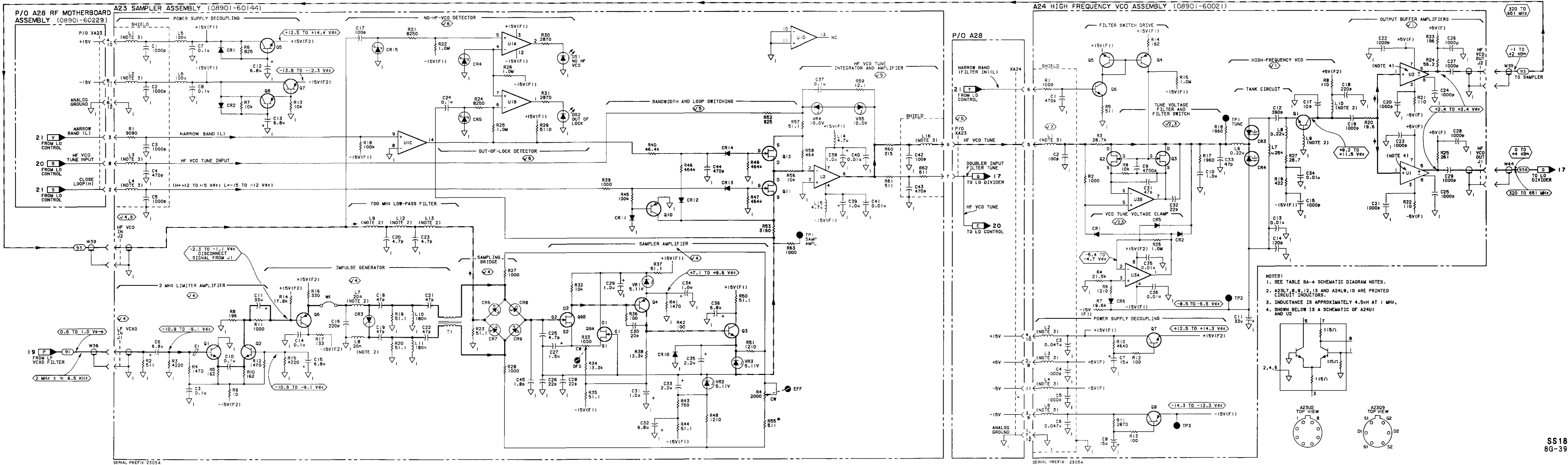

A22 Component Coordinates

COMP	X,Y	COMP	X,Y	COMP	X,Y	COMP	X,Y	COMP	X,Y
C1	B,3	E2	B,2	R20	A,2				
C2	B,2	J1	A,1	R21	A,3				
C3	B,2	L1	B,2	R22	B,3				
C4	A,2	L2	B,2	R23	B,3				
C5	A,3	L3	B,3	R24	B,2				
C6	B,2	L4	A,2	R25	B,2				
C7	A,2	L5	A,2	R26	A,2				
C8	B,1	L6	A,3	R27	A,2				
C9	A,2	L7	B,1	R28	A,2				
C10	B,2	L8	B,2	R29	B,1				
C11	A,2	L9	A,2	R30	B,1				
C12	B,3	L10	A,1	R31	A,1				
C13	A,3			R32	B,1				
C14	B,3			R33	A,1				
C15	B,2	MP1	B,1	R34	A,1				
C16	B,2	MP2	A,2	R35	B,1				
C17	A,2	MP3	B,2	R36	B,1				
C18	A,2			R37	A,1				
C19	B,2	Q1	A,1	R38	A,2				
C20	A,2	Q2	A,1	R39	A,1				
C21	B,2	Q3	A,1						
C22	B,2	Q4	A,2	T1	B,2				
C23	A,,2	Q5	B,2	T2	A,2				
C24	A,1	Q6	B,2						
C25	B,1	Q7	A,2	TP1	A,2				
C26	B,1	Q8	B,2	TP2	B,2				
C27	A,1	Q9	A,3						
C28	A,1			Y1	B,2				
				Y2	A,2				
CR1	B,2	R1	A,3						
CR2	B,2	R2	A,3						
CR3	A,2	R3	B,3						
CR4	A,2	R4	A,3						
CR5	B,2	R5	B,2						
CR6	B,2	R6	B,2						
CR7	B,2	R7	B,3						
CR8	A,2	R8	A,2						
CR9	A,2	R9	A,3						
CR10	B,3	R10	A,3						
CR11	A,3	R11	B,2						
CR12	B,3	R12	B,2						
CR13	A,3	R13	A,2						
CR14	B,2	R14	A,3						
CR15	B,2	R15	B,3						
CR16	B,2	R16	A,3						
		R17	B,2						
		R18	A,2						
E1	B,2	R19	B,2						

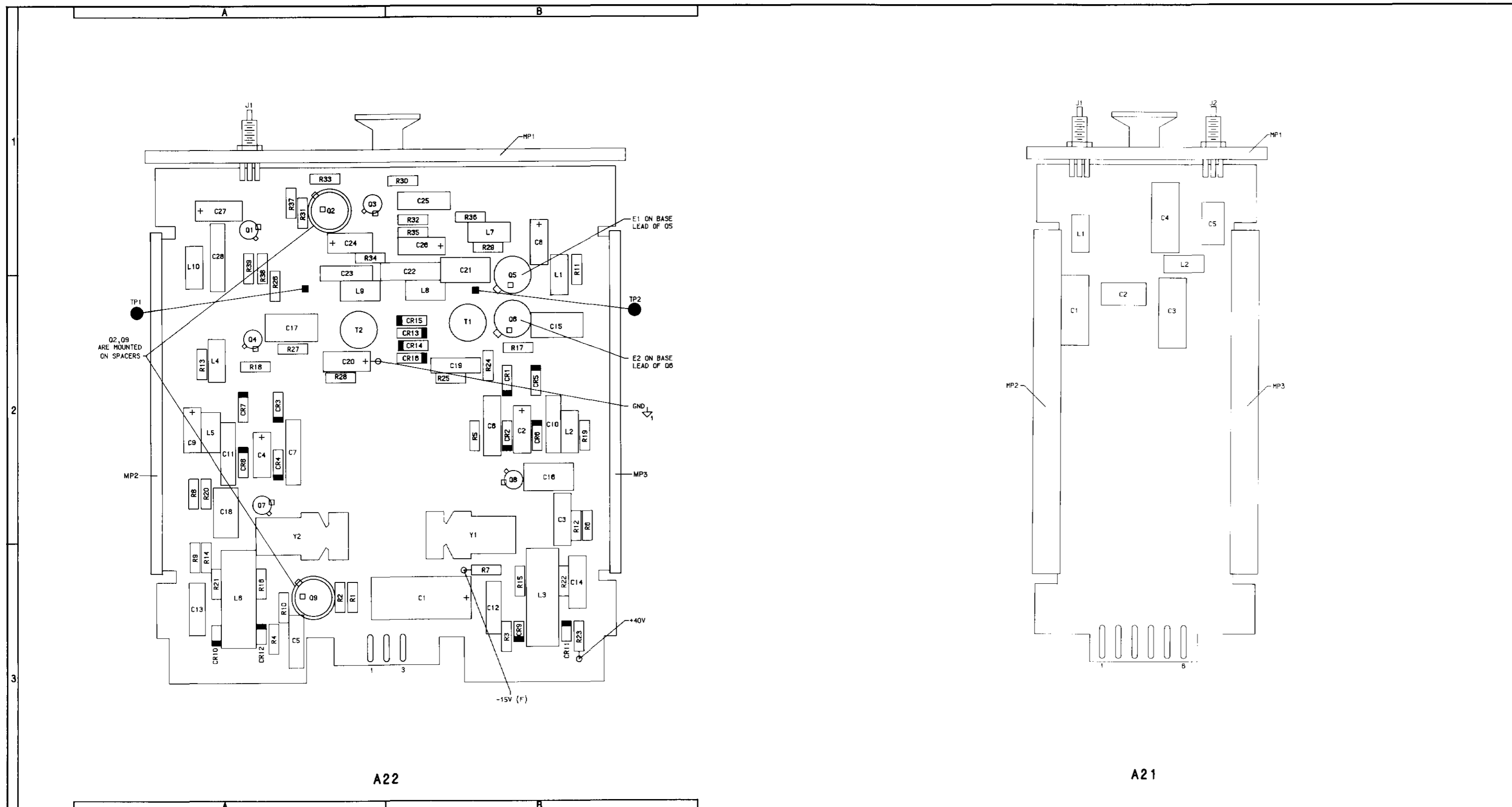

Component Locators

A23 SAMPLER
A24 HIGH FREQUENCY VCO **SS18**

SEE REVERSE SIDE

CHANGES

All serial prefixes	On the A22 schematic: <ul style="list-style-type: none">• <u>L2</u> - Change the value of A22L2 to 1.2uH.

A22 LOW FREQUENCY VCXO ASSEMBLY (08901-60007) (1)

P/O A28
RF MOTHERBOARD
ASSEMBLY
(08901-60229)

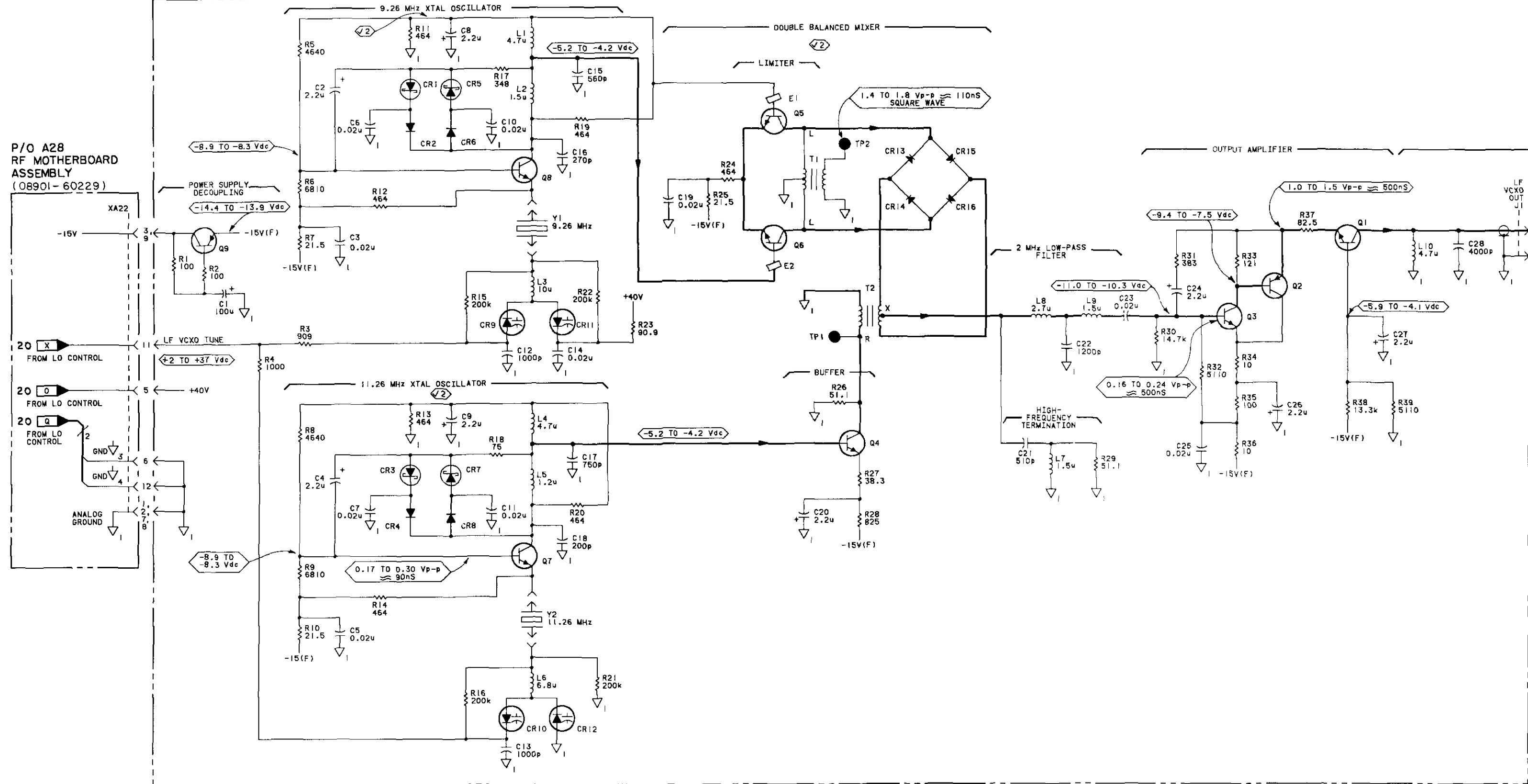

A21 LOW FREQUENCY VCXO
FILTER ASSEMBLY (08901-60025) (3)

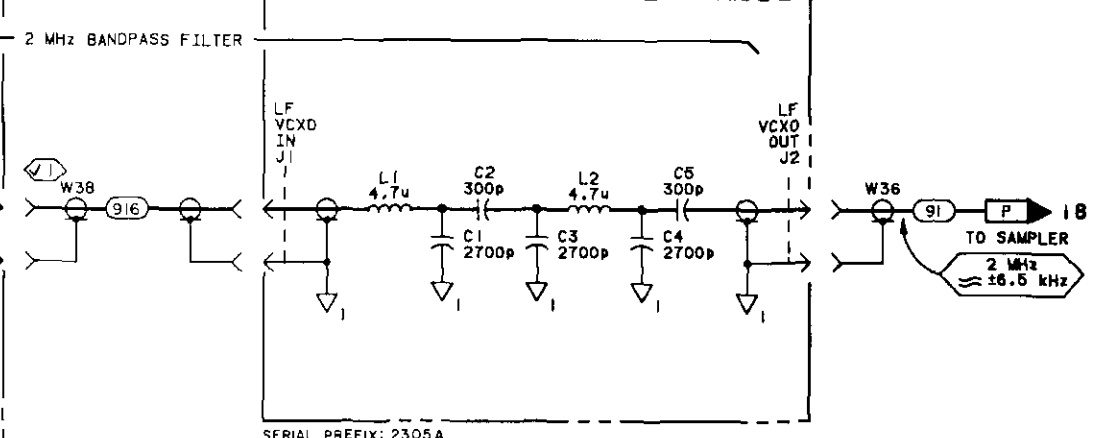

NOTES
1. SEE TABLE 8A-4 SCHEMATIC DIAGRAM NOTES.

SERIAL PREFIX: 2305A

A20 Component Coordinates (1 of 2) (2627A AND ABOVE)

COMP	X,Y	COMP	X,Y	COMP	X,Y	COMP	X,Y	COMP	X,Y
C1	A,3	MP1	B,1	R24	A,1	U13	B,2		
C2	A,3			R25	A,1	U14	A,2		
C3	B,3	Q1	B,1	R26	A,1	U23	B,2		
C4	B,3	Q2	B,1	R29	A,2				
C5	A,3	Q3	B,1	R30	A,2	VR1	A,2		
C6	A,3	Q4	B,1	R31	A,2				
C7	B,2	Q5	B,1	R32	A,2	W1	B,3		
C8	B,2	Q6	B,1	R33	A,2				
C9	B,2	Q7	B,1	R34	A,2				
C10	A,2	Q8	A,2	R35	A,2				
C11	A,2	Q9	A,1	R36	A,2				
C12	B,2	Q10	A,1	R37	B,2				
C13	B,1	Q11	A,2	R40	B,2				
C14	A,2	Q12	A,2	R42	A,2				
C15	A,3	Q13	A,2	R43	B,2				
C16	A,2	Q19	A,2	R44	B,2				
C17	A,2	Q20	A,2	R45	A,2				
C18	A,2	Q21	A,2	R46	A,2				
C20	A,2	Q22	A,2	R47	A,2				
C24	A,2	Q23	A,2	R48	A,2				
		Q24	A,2	R51	A,2				
		Q26	A,3	R52	B,2				
		Q27	A,3	R56	A,2				
CR1	A,1			R57	A,2				
CR2	A,1			R58	A,2				
CR5	A,3	R1	A,1	R59	B,2				
CR6	A,2	R2	A,2	R60	A,2				
CR7	A,2	R3	A,2	R61	A,2				
CR8	A,2	R4	A,1	R70	B,2				
CR9	A,2	R5	A,2	R71	B,2				
CR12	B,2	R6	A,3	R72	A,2				
CR13	B,2	R7	A,3	R73	A,2				
CR14	B,2	R8	A,3	R74	A,2				
CR15	B,2	R9	A,3						
CR16	B,2	R10	A,3						
CR17	B,2	R11	A,2	TP1	A,1				
CR18	B,2	R12	A,2	TP2	A,1				
CR19	B,2	R13	A,3	TP3	A,1				
CR20	A,2	R14	A,3	TP4	B,1				
CR22	A,2	R15	A,2						
CR24	B,2	R16	B,2	U1	A,2				
CR25	B,2	R17	A,2	U2	B,2				
DS3	A,2	R18	B,2	U3	B,2				
DS4	A,2	R19	B,1	U4	A,2				
		R20	A,1	U5	A,3				
L1	B,3	R21	A,1	U6	B,2				
L2	B,3	R22	A,1	U10	B,2				
L3	B,3	R23	A,1	U12	B,2				

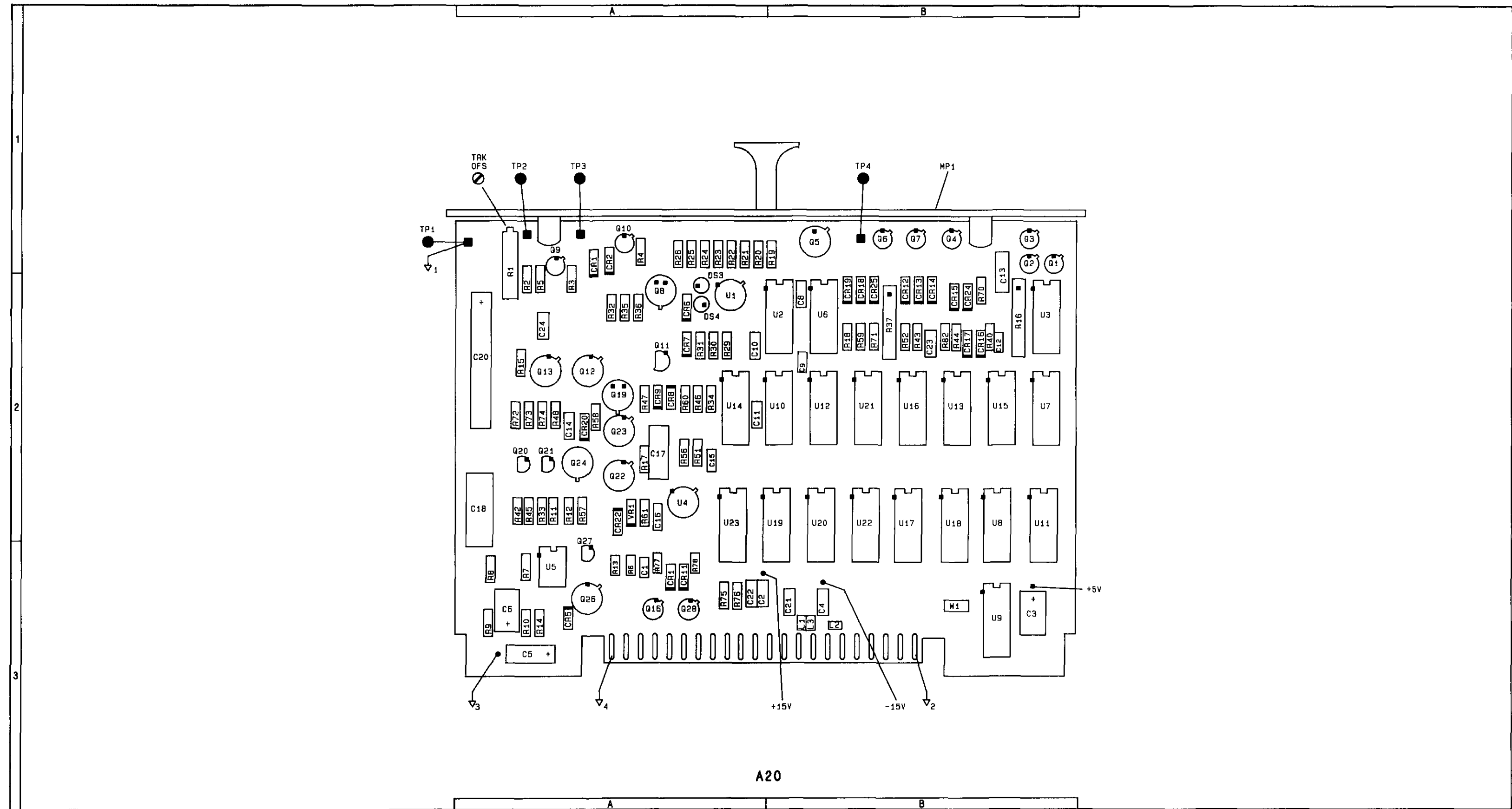

A20

Component Locator

A21 LOW FREQUENCY VCXO FILTER
 A22 LOW FREQUENCY VCXO
 SEE REVERSE SIDE

SS19

CHANGES**All Serial Prefixes**

On the A20 schematic:

- R47 - Change the value of R47 to 26.1k.

2406A and above

On the A20 schematic:

- A20R19-R26 - Make the following value changes:

R19	61.9k
R20	28.7k
R21	13.3k
R22	6190
R23	2610
R24	464k
R25	237k
R26	121k

2627A and above

On the schematic:

- Use SS20 (2627A) on page 8G-44 and 8G-45.

2804A and above

On the Component Coordinates:

- CR21 - Add CR21 A,1 to the coordinates.

On the Component Locator:

- CR21,C7,C19 - Add CR21 between R35 and R36 with the polarity nearest Q10. Add C7 between U12 and U21. Add C19 between C12 and R16.

On the schematic:

- R35, CR21, R32 - On the lower left portion of the schematic, next to DATA LATCH, locate R35 and change the value to 3.48k. Add CR21 between R35 and Q8A with the anode connecting to R35 and cathode connecting to Q8A. Below Q8A change the value of R32 to 9.09k.
- On the lower left corner of the schematic change the serial prefix to "2804A and above".

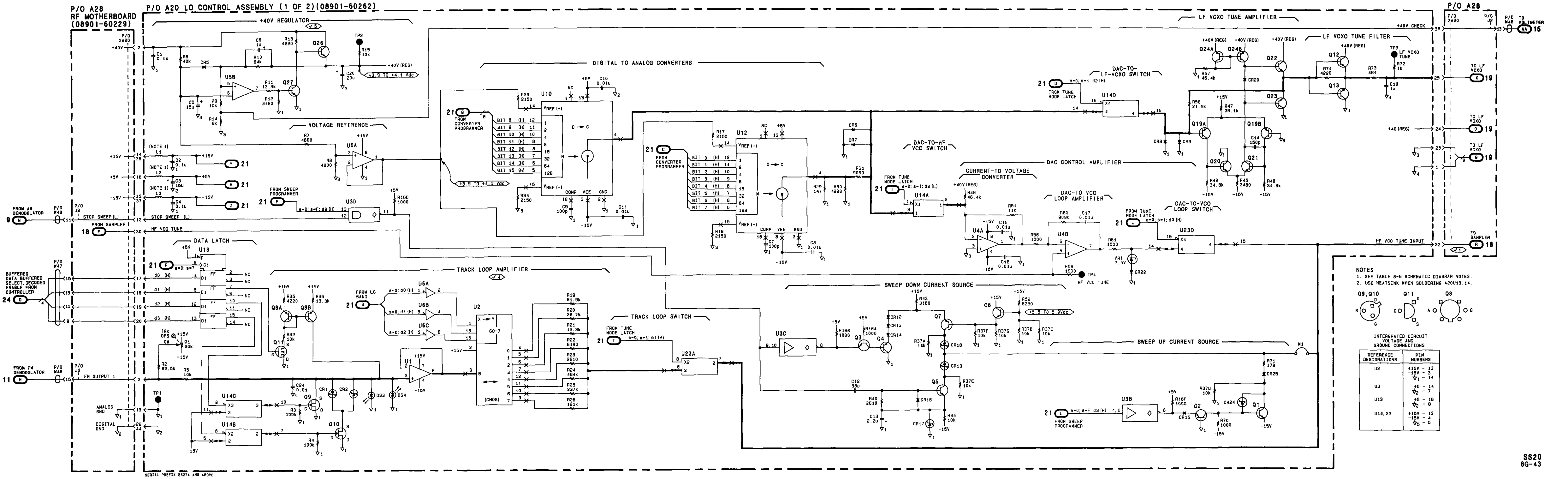

NOTES
 1. SEE TABLE 8-6 SCHEMATIC DIAGRAM NOTES.
 2. USE HEATSINK WHEN SOLDERING A20U13, 14.

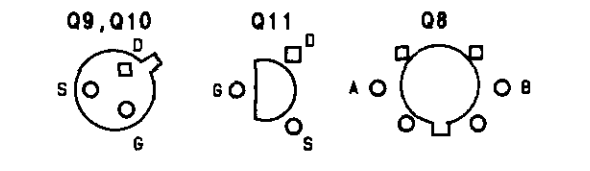

INTEGRATED CIRCUIT VOLTAGE AND GROUND CONNECTIONS

REFERENCE DESIGNATIONS	PIN NUMBERS
U2	+15V - 13 -15V - 3 V1 - 14
U3	+5 - 14 V2 - 7
U19	+5 - 16 V2 - 8
U14, 23	+15V - 13 -15V - 4 V5 - 5

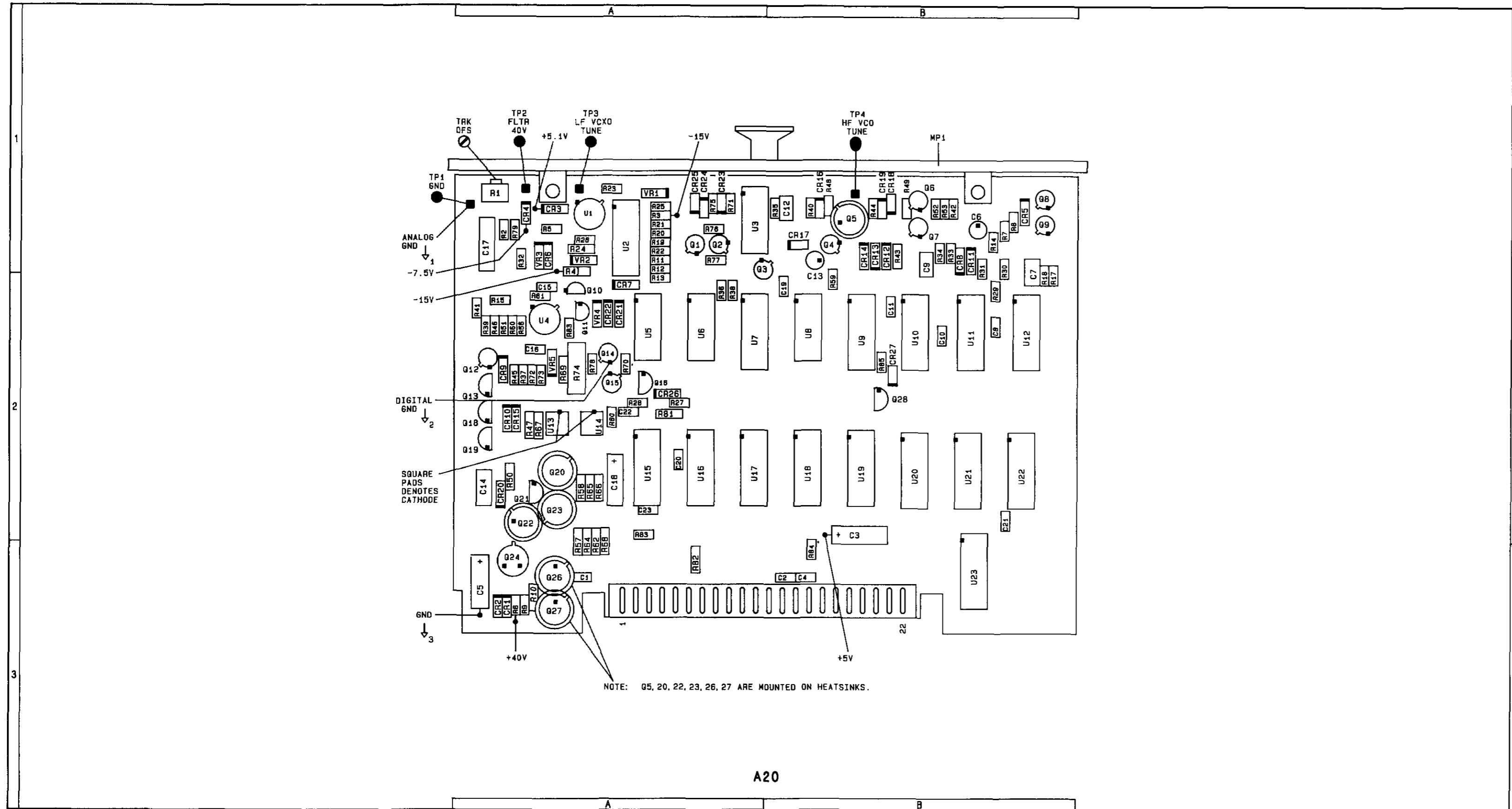

A20

Component Locator

COMP	X,Y	COMP	X,Y	COMP	X,Y	COMP	X,Y	COMP	X,Y
C1	A,3	Q1	A,1	R22	A,1	R69	A,2		
C2	B,3	Q2	A,1	R23	A,1	R70	A,2		
C3	B,2	Q3	A,2	R24	A,1	R71	A,1		
C4	B,3	Q4	B,1	R25	A,1	R72	A,2		
C5	A,3	Q5	B,1	R26	A,1	R73	A,2		
C6	B,1	Q6	B,1	R27	A,2	R74	A,2		
C7	B,1	Q7	B,1	R28	A,2	R75	A,1		
C8	B,2	Q8	B,1	R29	B,2	R76	A,1		
C9	B,1	Q9	B,1	R30	B,1	R77	A,1		
C10	B,2	Q10	A,2	R31	B,1	R78	A,2		
C11	B,2	Q11	A,2	R32	A,1	R79	A,1		
C12	B,1	Q12	A,2	R33	B,1	R83	A,2		
C13	B,1	Q13	A,2	R34	B,1	R84	B,2		
C14	A,2	Q14	A,2	R35	B,1				
C15	A,2	Q15	A,2	R36	A,2	U1	A,1		
C16	A,2	Q18	A,2	R37	A,2	U2	A,1		
C17	A,1	Q19	A,2	R38	A,2	U3	A,1		
C18	A,2	Q20	A,2	R39	A,2	U4	A,2		
		Q21	A,2	R40	B,1	U5	A,2		
CR1	A,3	Q22	A,2	R41	A,2	U6	A,2		
CR2	A,3	Q23	A,2	R42	B,1	U10	B,2		
CR3	A,1	Q24	A,3	R43	B,1	U12	B,2		
CR4	A,1	Q26	A,3	R44	B,1	U13	A,2		
CR5	B,1	Q27	A,3	R45	A,2	U14	A,2		
CR6	A,1			R46	A,2				
CR7	A,2	R1	A,1	R47	A,2	VR1	A,1		
CR8	B,1	R2	A,1	R48	B,1	VR2	A,1		
CR9	A,2	R3	A,1	R49	B,1	VR3	A,1		
CR10	A,2	R4	A,1	R50	A,2	VR4	A,2		
CR12	B,1	R5	A,1	R51	A,2	VR5	A,2		
CR13	B,1	R6	A,3	R52	B,1				
CR14	B,1	R7	B,1	R53	B,1				
CR15	A,2	R8	B,1	R56	A,2				
CR16	B,1	R9	A,3	R57	A,2				
CR17	B,1	R10	A,3	R58	A,2				
CR18	B,1	R11	A,1	R59	B,1				
CR19	B,1	R12	A,1	R60	A,2				
CR20	A,2	R13	A,1	R61	A,2				
CR21	A,2	R14	B,1	R62	A,2				
CR22	A,2	R15	A,2	R63	A,2				
CR23	A,1	R17	B,1	R64	A,2				
CR24	A,1	R18	B,1	R65	A,2				
CR25	A,1	R19	A,1	R66	A,2				
		R20	A,1	R67	A,2				
MP1	B,1	R21	A,1	R68	A,2				

A20 LO CONTROL (1 OF 2)
DIGITAL CIRCUITS
SEE REVERSE SIDE SERIAL PREFIX: 2627A AND ABOVE

SS20

P/O A20 LO CONTROL ASSEMBLY (1 OF 2) (08901-60185)

P/O A28
RF MOTHERBOARD
ASSEMBLY
(08901-60229)

P/O A28

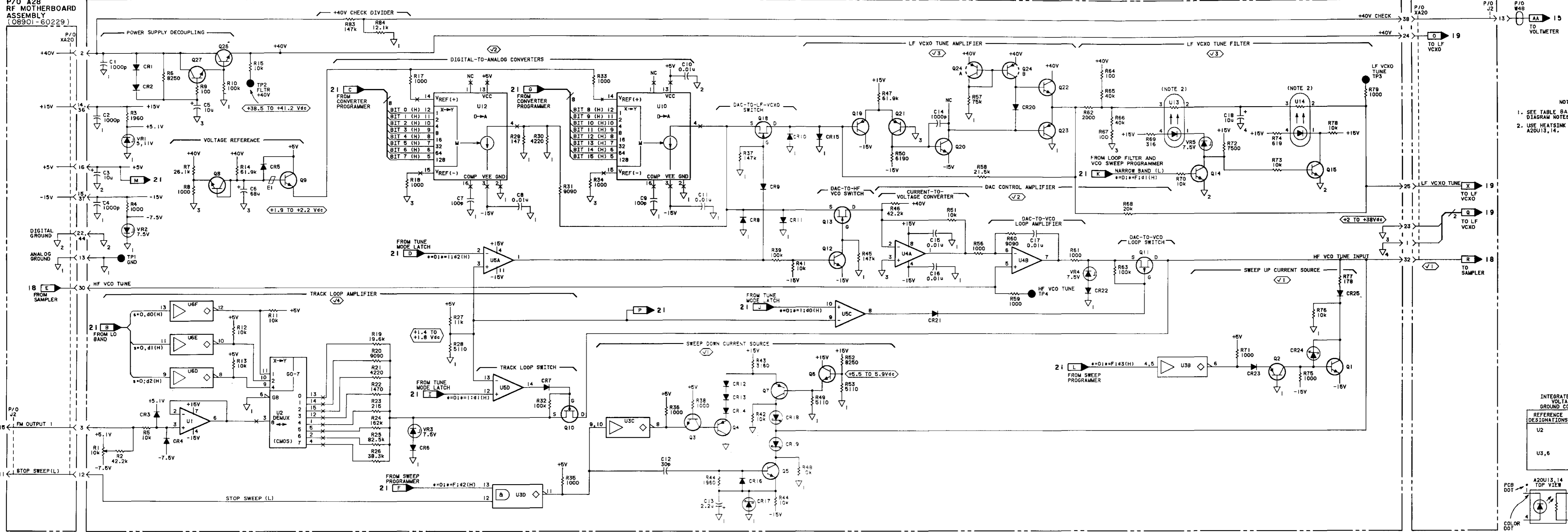

- NOTES
- SEE TABLE BA-4 SCHEMATIC DIAGRAM NOTES.
 - USE HEATSINK WHEN SOLDERING A20U13,14.

INTEGRATED CIRCUIT VOLTAGE AND GROUND CONNECTIONS

REFERENCE DESIGNATIONS	PIN NUMBERS
U2	+5.1V - 16
	-5.1V - 7
	1 - 8
U3,6	+5V - 14
	2 - 7

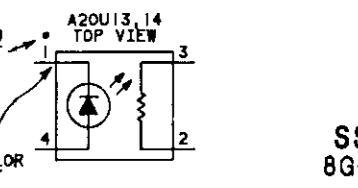

SERIAL PREFIX: 2314A TO 2622A

A20 Component Coordinates (2 of 2) - (2627A AND ABOVE)

COMP	X,Y	COMP	X,Y	COMP	X,Y	COMP	X,Y	COMP	X,Y
C19	B,2								
C21	B,3								
C22	A,3								
C23	B,2								
CR10	A,3								
CR11	A,3								
MP1	B,1								
Q16	A,3								
Q28	A,3								
R16	B,2								
R75	A,3								
R76	A,3								
R77	A,3								
R78	A,3								
R82	B,2								
U3	B,2								
U6	B,2								
U7	B,2								
U8	B,2								
U9	B,3								
U11	B,2								
U15	B,2								
U16	B,2								
U17	B,2								
U18	B,2								
U19	B,2								
U20	B,2								
U21	B,2								

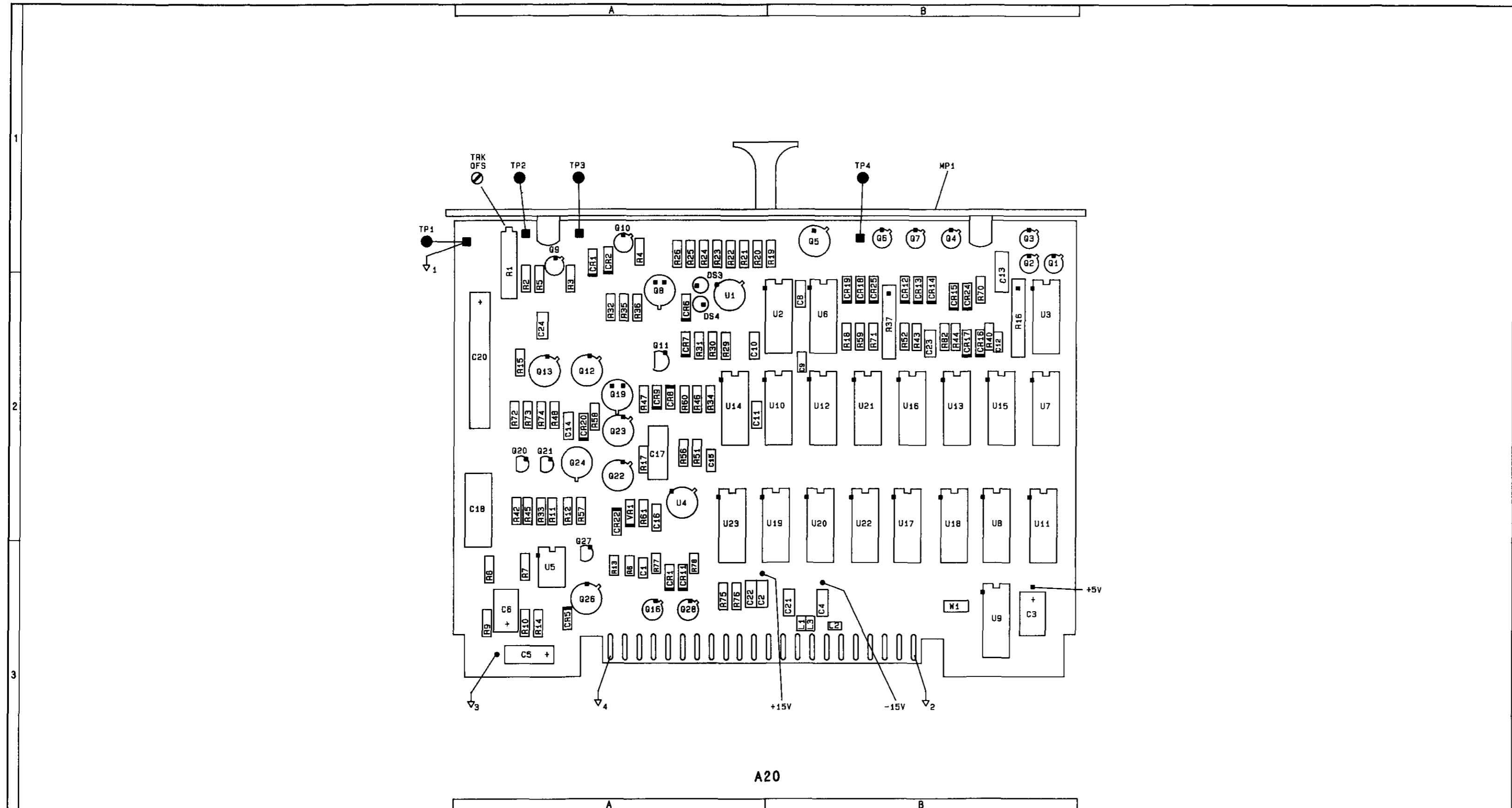

A20

Component Locator

A20 LO CONTROL (1 OF 2)
 ANALOG CIRCUITS
 SEE REVERSE SIDE SERIAL PREFIX: 2314A TO 2622A

SS20

P/O A28 RF MOTHERBOARD ASSEMBLY (08901-60229)

P/O A20 LO CONTROL ASSEMBLY (2 OF 2) (08901-60262)

P/O A28

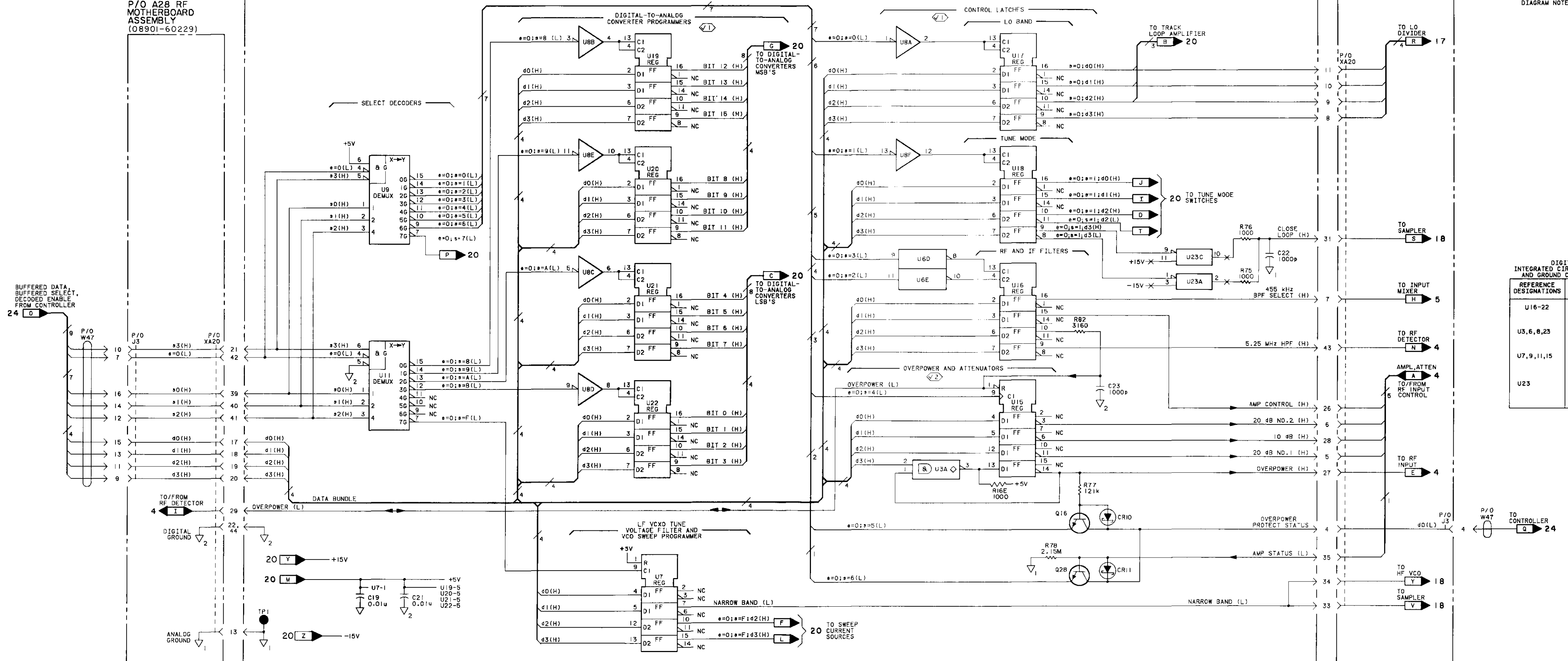

NOTES
1. SEE TABLE BA-4 SCHEMATIC DIAGRAM NOTES.

DIGITAL INTEGRATED CIRCUIT VOLTAGE AND GROUND CONNECTIONS

REFERENCE DESIGNATIONS	VOLTAGE	PIN NUMBERS
U16-22	+5V	5
	▽ ₂	12
U3,6,8,23	+5V	14
	▽ ₂	7
U7,9,11,15	+5V	16
	▽ ₂	8
U23	+15	13
	-15	4
	▽ ₁	5

SERIAL PREFIX: 2627A AND ABOVE

A20 Component Coordinates (2 of 2) - (2314A TO 2622A)

COMP	X,Y	COMP	X,Y	COMP	X,Y	COMP	X,Y	COMP	X,Y
C19	B,1								
C20	A,2								
C21	B,2								
C22	A,2								
C23	A,2								
CR26	A,2								
CR27	B,2								
Q16	A,2								
Q28	B,2								
R80	A,2								
R81	A,2								
R82	A,3								
R85	B,2								
U5	A,2								
U7	A,2								
U8	B,2								
U9	B,2								
U11	B,2								
U15	A,2								
U16	A,2								
U17	A,2								
U18	B,2								
U19	B,2								
U20	B,2								
U21	B,2								
U22	B,2								
U23	B,3								

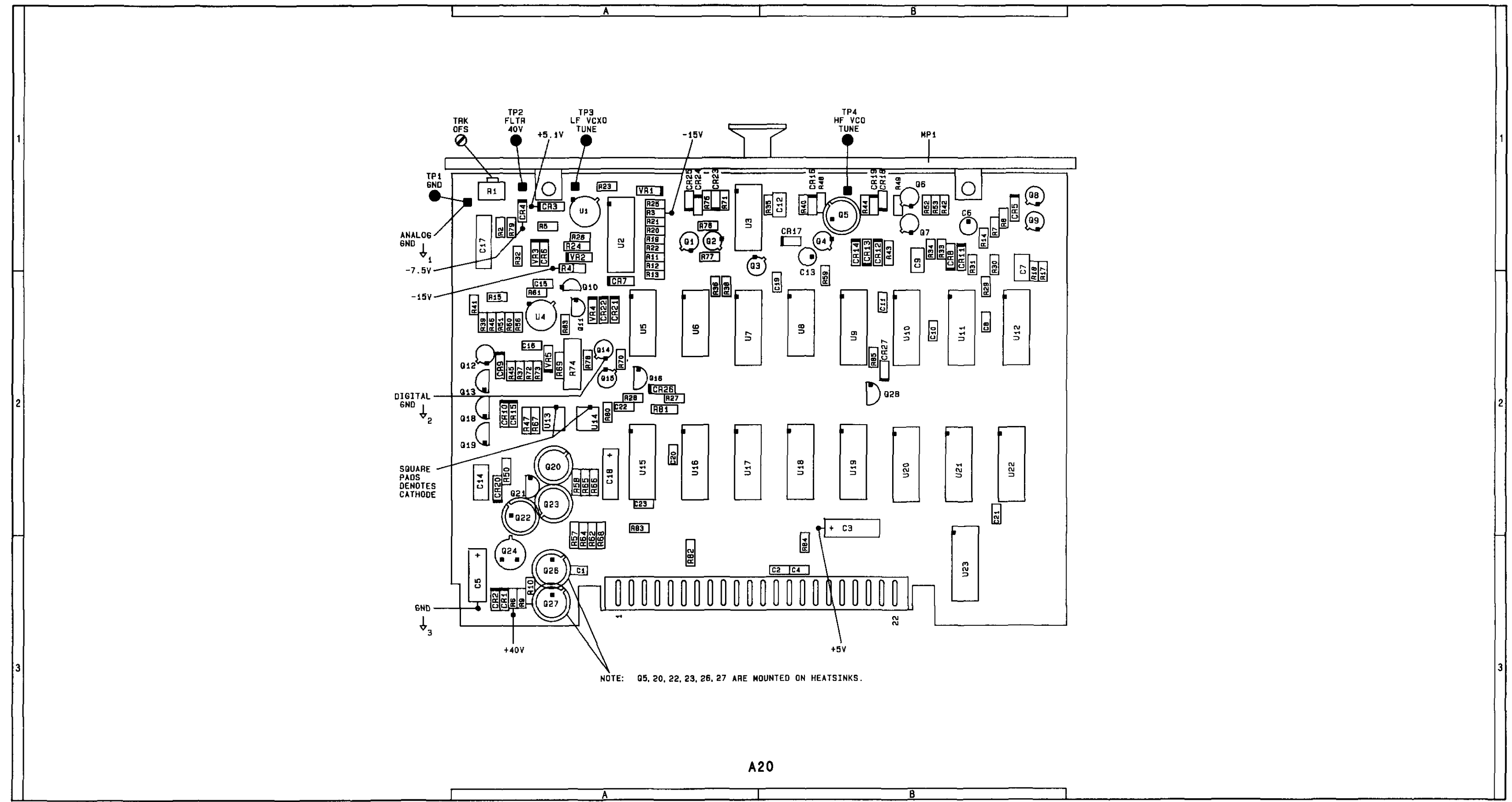

NOTE: Q5, 20, 22, 23, 26, 27 ARE MOUNTED ON HEATSINKS.

A20

Component Locator

A20 LO CONTROL (1 OF 2)
 ANALOG CIRCUITS
 SERIAL PREFIX: 2627A AND ABOVE

SS21

SEE REVERSE SIDE

P/O A28 RF MOTHERBOARD ASSEMBLY (08901-60229)

P/O A20 LO CONTROL ASSEMBLY (2 OF 2) (08901-60185)

P/O A28

NOTES
1. SEE TABLE BA-4 SCHEMATIC DIAGRAM NOTES.

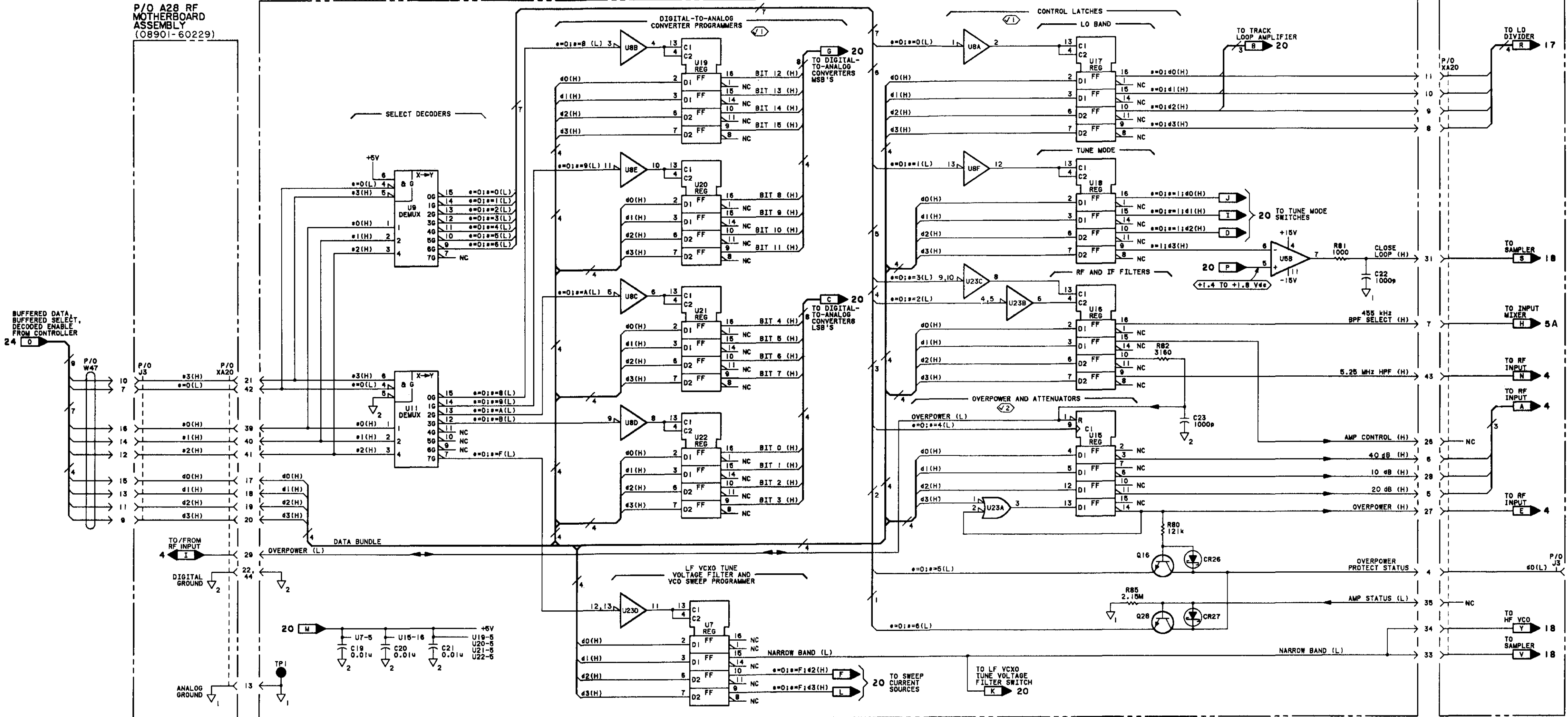

DIGITAL INTEGRATED CIRCUIT VOLTAGE AND GROUND CONNECTIONS

REFERENCE DESIGNATIONS	PIN NUMBERS
U7, 16-22	+5V - 5
	∇ ₂ - 12
U8, 23	+5V - 14
	∇ ₂ - 7
U9, 11, 15	+5V - 16
	∇ ₂ - 8

SERIAL PREFIX: 2314A TO 2622A

SS21 8Q-49

A11 Component Coordinates (1 of 2)

COMP	X,Y	COMP	X,Y	COMP	X,Y	COMP	X,Y	COMP	X,Y
C2	B,3	R26	B,2						
C3	B,1	R27	A,2						
C5	B,1	R30	B,2						
C8	A,2	R31	B,1						
C9	B,2	R32	B,2						
C14	B,1	R36	A,2						
C15	A,1								
C17	A,2	TP1	A,1						
C18	B,2	TP4	A,1						
C20	B,1	TP5	B,1						
C22	B,2								
C26	B,1	U2	A,2						
C28	B,2	U3	B,2						
C29	B,2	U4	B,2						
C30	B,1	U8	A,2						
		U9	B,2						
		U10	B,2						
CR1	B,1	U20	A,3						
CR2	B,1	U21	B,1						
CR3	B,1								
CR4	B,2								
CR5	B,2								
DS1	B,1								
J4	A,1								
J5	B,1								
J6	B,1								
L2	A,2								
MP1	B,1								
Q3	B,1								
Q4	B,2								
R4	A,2								
R5	B,2								
R6	B,1								
R8	B,2								
R9	B,1								
R10	B,2								
R11	A,2								
R12	A,2								
R18	A,2								
R20	B,1								
R25	B,2								

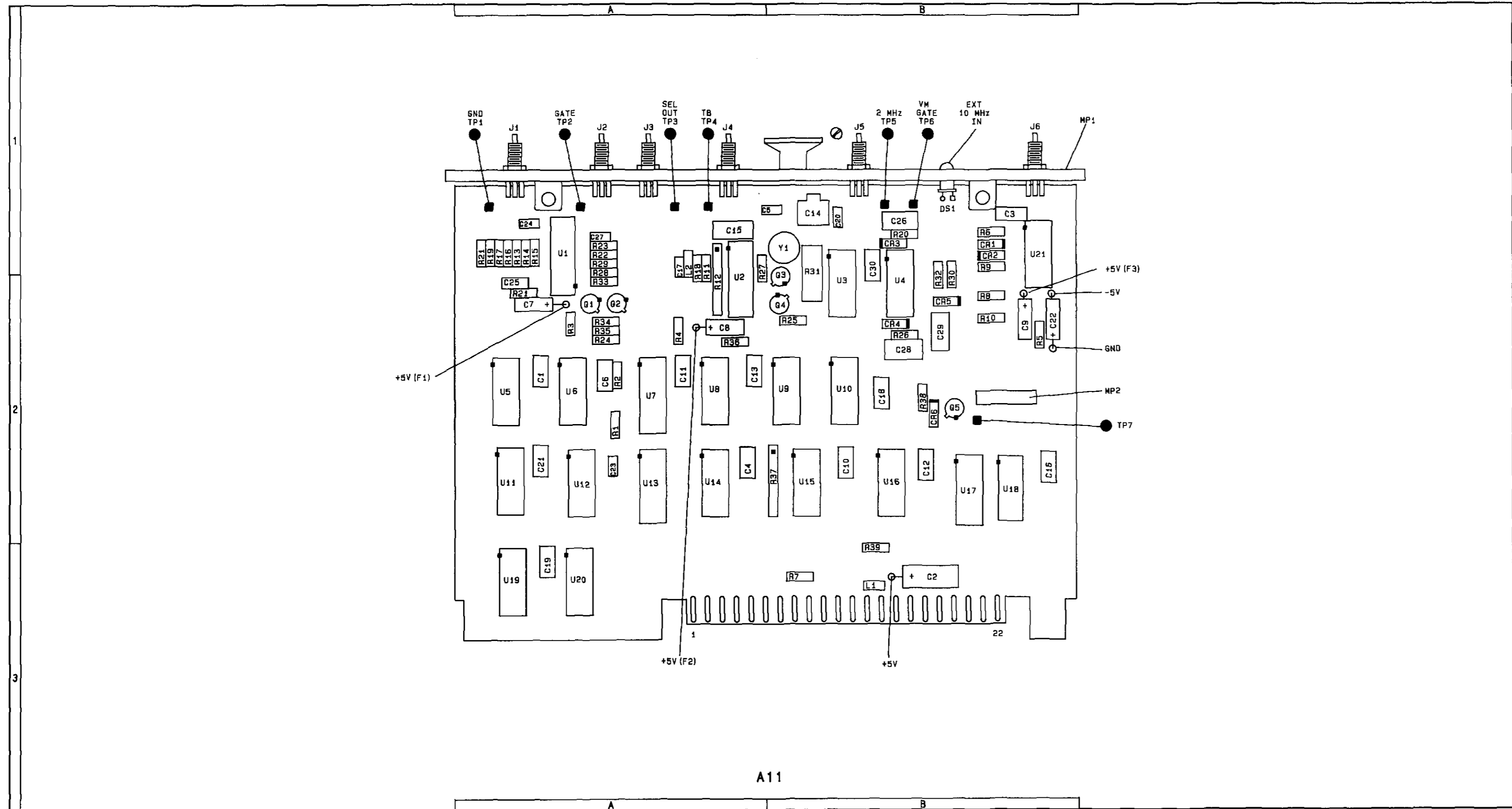

Component Locator

A20 LO CONTROL (2 OF 2)
DIGITAL CIRCUITS
SEE REVERSE SIDE SERIAL PREFIX: 2314A TO 2622A

SS21

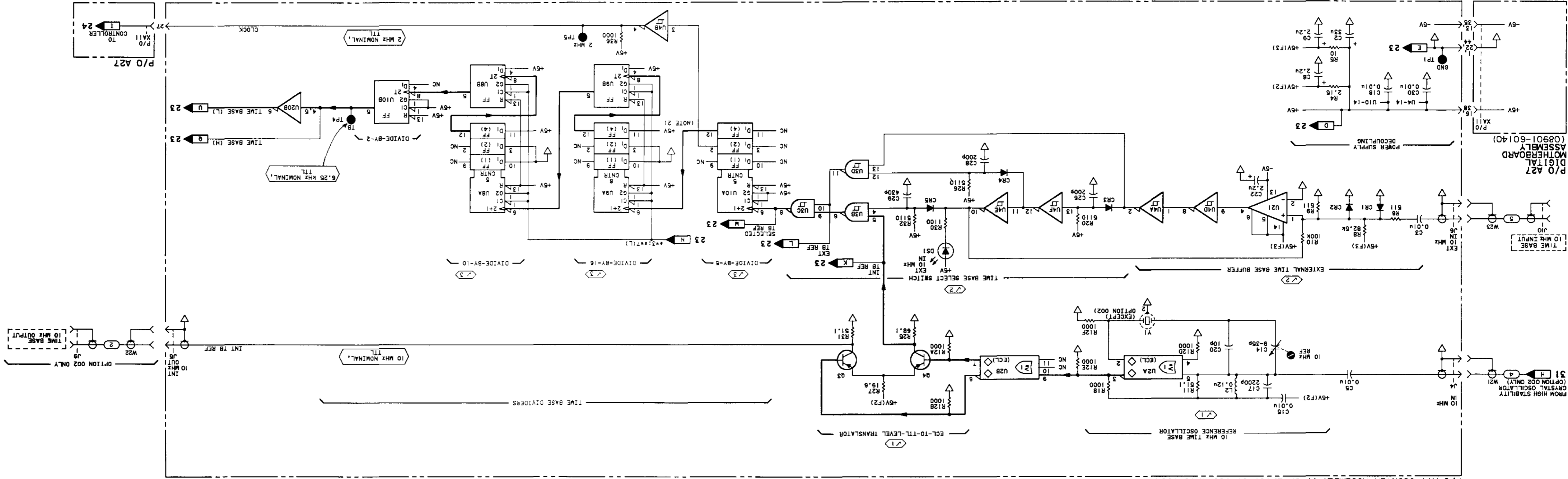

- NOTES
1. SEE TABLE 8A-4 SCHEMATIC DIAGRAM NOTES.
 2. THE OUTPUTS FROM PIN 2 AND PIN 12 OF U10A ARE BOTH 2 MHz (10 MHz \div 5). THE DIFFERENCE IN THE OUTPUTS IS THE RESPECTIVE DUTY CYCLES.

DIGITAL INTEGRATED CIRCUIT VOLTAGE AND GROUND CONNECTIONS

REFERENCE PIN DESIGNATIONS	VOLTAGE	DESIGNATIONS
U2	+5V(F1)-1, 16	8
U3, 4, 8-10, 20	+5V	14
	-5V	7

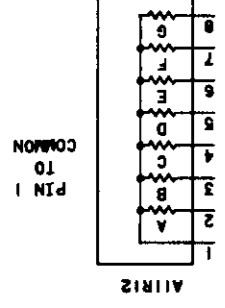

A11 Component Coordinates (2 of 2)

COMP	X,Y	COMP	X,Y	COMP	X,Y	COMP	X,Y	COMP	X,Y
C1	A,2	R35	A,2						
C4	A,2	R37	B,2						
C6	A,2	R38	B,2						
C7	A,2	R39	B,3						
C10	B,2								
C11	A,2	TP2	A,1						
C12	B,2	TP3	A,1						
C13	A,2	TP6	B,1						
C16	B,2	TP7	B,2						
C19	A,3								
C21	A,2	U1	A,1						
C23	A,2	U4	B,2						
C24	A,1	U5	A,2						
C25	A,2	U6	A,2						
C27	A,1	U7	A,2						
		U11	A,2						
CR6	B,2	U12	A,2						
		U13	A,2						
J1	A,1	U14	A,2						
J2	A,1	U15	B,2						
J3	A,1	U16	B,2						
		U17	B,2						
Q1	A,2	U18	B,2						
Q2	A,2	U19	A,3						
Q5	B,2	U20	A,3						
		Y1	B,1						
R1	A,2								
R2	A,2								
R3	A,2								
R7	B,3								
R13	A,1								
R14	A,1								
R15	A,1								
R16	A,1								
R17	A,1								
R19	A,1								
R21	A,1								
R22	A,1								
R23	A,1								
R24	A,2								
R28	A,1								
R29	A,1								
R33	A,2								
R34	A,2								

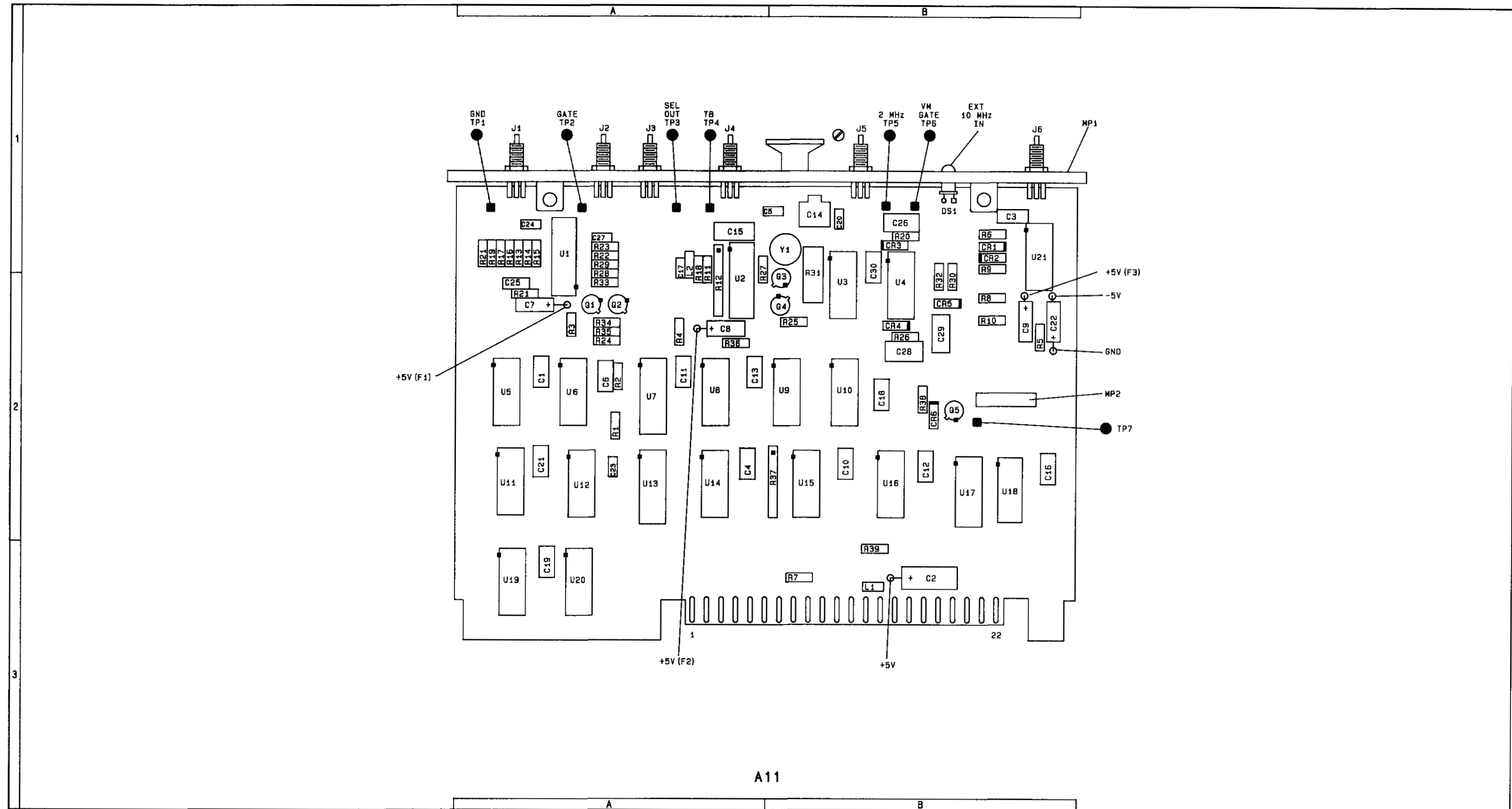

Component Locator

A11 COUNTER (1 OF 2)
TIME BASE CIRCUITS **SS22**
SEE REVERSE SIDE

CHANGES

All serial prefixes

On the A11 schematic:

- **R16** - In the upper left portion of the schematic, above and to the right of U14A, change the value of R16 to 1000 ohms.

P/O A11 COUNTER ASSEMBLY (2 OF 2) (08901-60093) (OPTION 002:08901-60018)

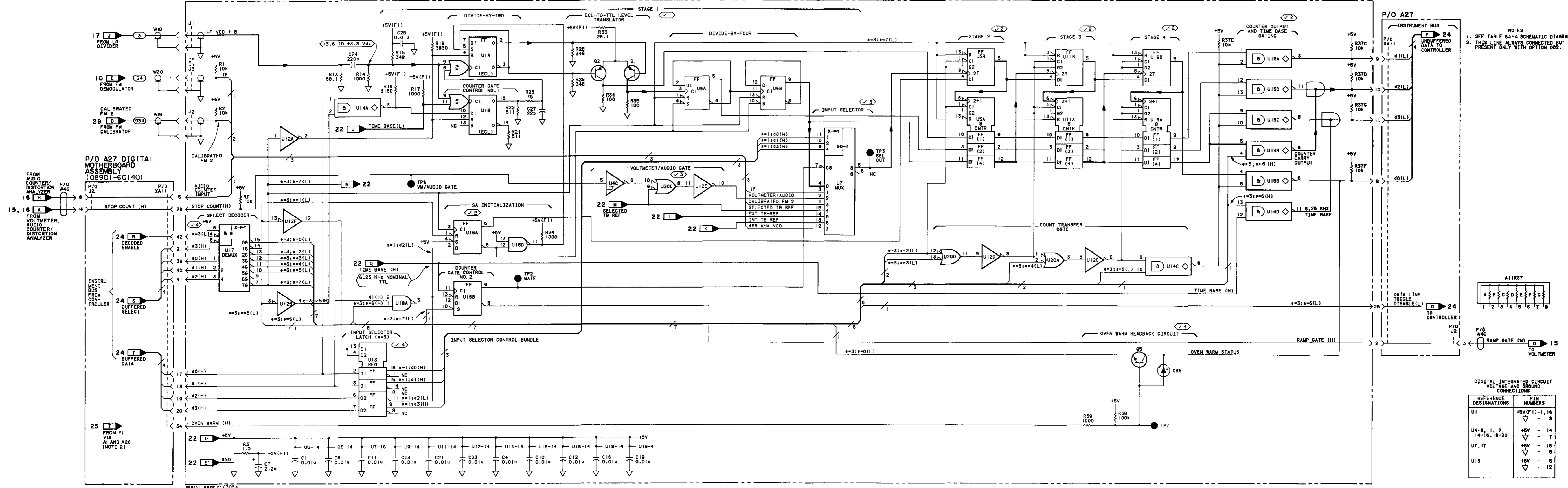

- NOTES
1. SEE TABLE 8A-4 SCHEMATIC DIAGRAM NOTES.
 2. THIS LINE ALWAYS CONNECTED BUT SIGNAL PRESENT ONLY WITH OPTION 002.

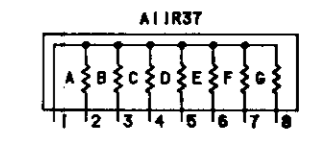

DIGITAL INTEGRATED CIRCUIT VOLTAGE AND GROUND CONNECTIONS

REFERENCE DESIGNATIONS	PIN NUMBERS
U1	+5V(F1)-1, 16 - 8
U4-6, 11, 12, 14-16, 18-20	+5V - 14 - 7
U7, 17	+5V - 16 - 8
U13	+5V - 5 - 12

A13 Component Coordinates

COMP	X,Y	COMP	X,Y	COMP	X,Y	COMP	X,Y	COMP	X,Y
BT1	B,1	Q3	B,2	U13	B,2				
		Q6	A,2						
C1	B,2			VR1	B,1				
C2	A,1	R1	B,2						
C3	A,2	R2	B,2	W1	A,2				
C4	A,2	R3	A,3	W2	A,2				
C5	B,2	R4	A,2						
C6	A,2	R5	A,2						
C7	B,2	R6	B,2						
C8	A,1	R7	B,2						
C9	A,2	R8	A,2						
C10	A,2	R9	B,1						
C11	A,2	R10	B,1						
C12	B,2	R11	B,1						
C13	B,2	R12	B,1						
C14	B,2	R13	B,2						
C15	B,2	R14	B,1						
C16	B,2	R15	B,1						
C17	B,1	R16	B,2						
C18	B,2	R17	B,1						
C19	B,2	R18	B,1						
C20	B,2	R19	B,2						
C21	B,2	R20	A,2						
C22	A,1	R21	B,1						
		R22	B,2						
CR1	A,2	R23	B,2						
CR2	B,1	R24	B,2						
CR3	B,2	R25	B,2						
CR4	B,2	R26	B,2						
CR5	B,1	R27	B,2						
CR7	B,2	R28	B,2						
CR9	B,2	R29	A,1						
		R30	B,1						
DS1	A,1	U1	A,1						
DS2	A,1	U2	A,1						
DS3	A,1	U3	B,2						
DS4	A,1	U4	A,1						
		U5	A,2						
L1	B,2	U7	A,1						
MP1	A,1	U8	A,2						
MP2	B,1	U9	B,2						
		U10	A,2						
Q1	B,2	U11	B,2						
Q2	B,2	U12	B,2						

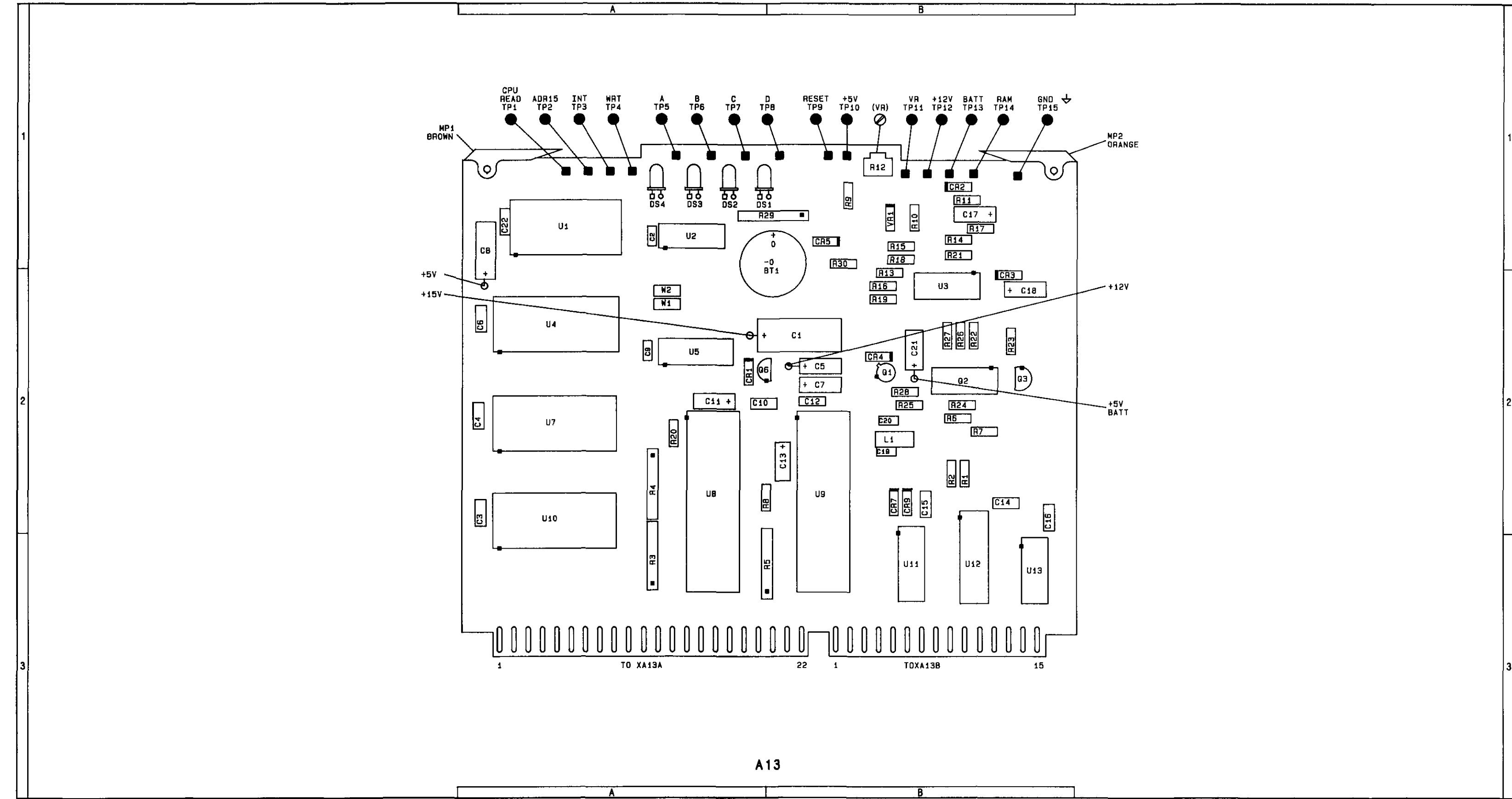

Component Locator

A11 COUNTER (2 OF 2) COUNTER CIRCUITS

SS23

SEE REVERSE SIDE

CHANGES

All serial prefixes	<p>On the A13 Schematic:</p> <ul style="list-style-type: none"> • U6 - On the lower left hand side of the schematic, locate U6 under +12V REGULATOR and change pin 1 to pin 3, and pin 3 to pin 1.
2531A and above	<p>On the A13 Schematic:</p> <ul style="list-style-type: none"> • C19, C20 - Under CENTRAL PROCESSING UNIT, change the value of C19 and C20 to 47 pF.
2550A and above	<p>On the A13 Schematic:</p> <ul style="list-style-type: none"> • R11 - In the center of the schematic, under POWER-ON RESET, change the value of R11 to 51.1 k.
2635A and above	<p>On the A13 Component Coordinates:</p> <ul style="list-style-type: none"> • C19, C20, L1 - Delete C19, C20 and L1. <p>On the A13 Component Locator:</p> <ul style="list-style-type: none"> • C19, C20, L1 - Delete C19, C20 and L1.
2635A and above	<p>On the A13 Schematic:</p> <ul style="list-style-type: none"> • C19, C20, L1 - Under CENTRAL PROCESSING UNIT, delete C19, C20 and L1.
2636A and above	<p>On the A27 Schematic:</p> <ul style="list-style-type: none"> • A27 - Change the part number of A27 DIGITAL MOTHERBOARD to 08902-60102. • Buffered Select Bullet "S" - On the right side, bullet "S" directs you to service sheets 23 and 28. Add service sheet 33. • Buffered Data Bullet "T" - On the right side, bullet "T" directs you to service sheets 23 and 28. Add service sheets 33 and 34. • Decoded Enable Bullet "R" - On the right side, bullet "R" directs you to service sheet 23. Add service sheet 33.

CHANGES

2804A and above	<p>On the A13 Component Locator:</p> <ul style="list-style-type: none">• 08901-60196 - Use the new component locator on page 8G-54.3.• DS1 - DS4 - Reference designators should read <u>top-to-bottom</u> DS1, DS2, DS3, DS4. <p>On the A13 Schematic:</p> <ul style="list-style-type: none">• 08901-60196 - Use the new schematic foldout on page 8G-54.5.• A13 - In the lower left hand corner of the schematic, change the serial prefix to read "2804A and above".
Errata	<p>On the A13 Schematic:</p> <ul style="list-style-type: none">• C21 - Under NONVOLATILE MEMORY SUPPLY, change the value of C21 to 0.22 μF.• C17 - Under POWER-ON RESET, change the value of C17 to 4.7 μF. <p>On the A13 Component Locator:</p> <ul style="list-style-type: none">• U6 - On page 8G-54, find U6 and move the polarity symbol to the opposite side of the component. Make the same change to U6 on the component locator on page 8G-54.3.

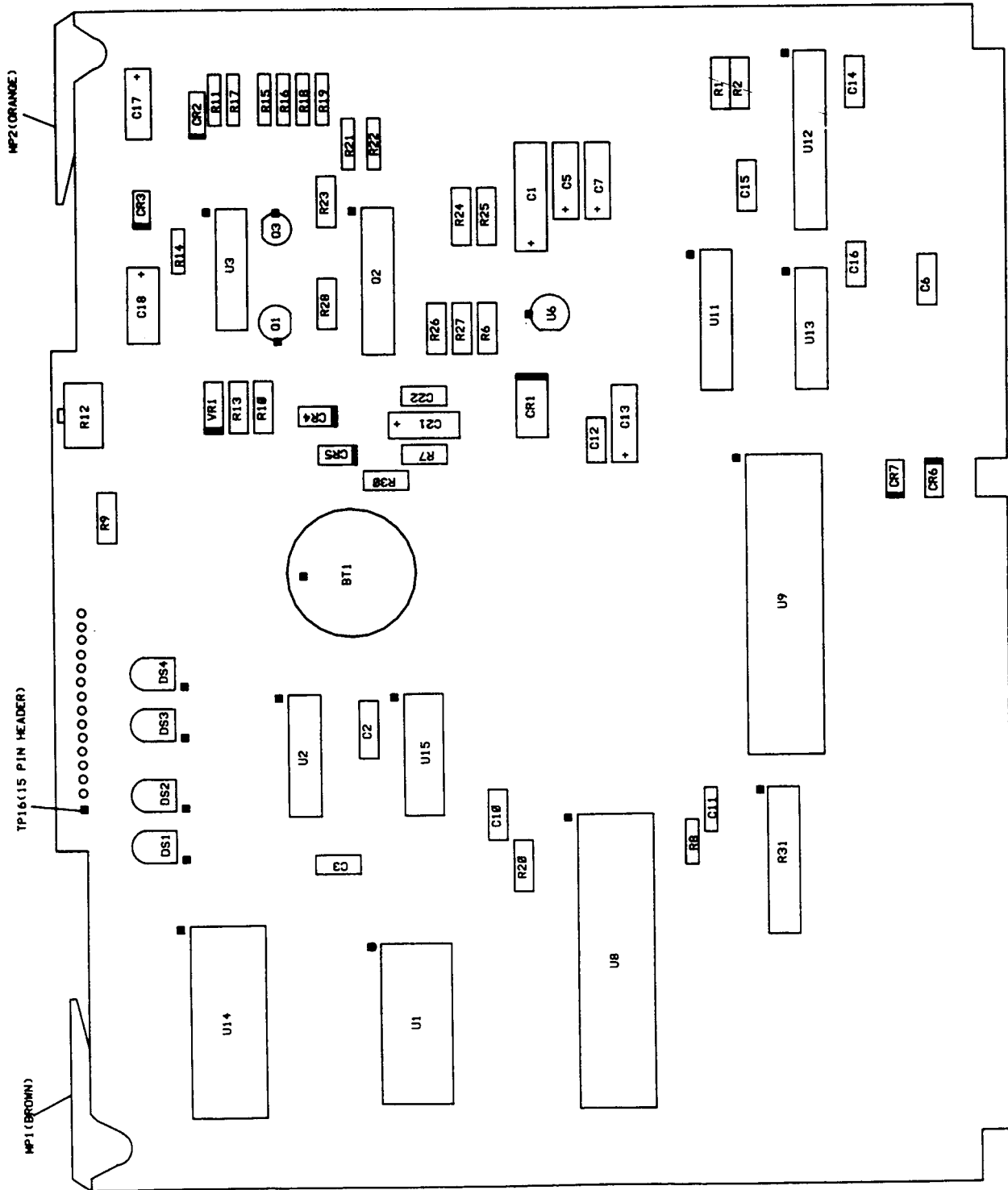

P/O A27 DIGITAL MOTHERBOARD ASSEMBLY (08901-60140)

A13 CONTROLLER ASSEMBLY (08901-60244)

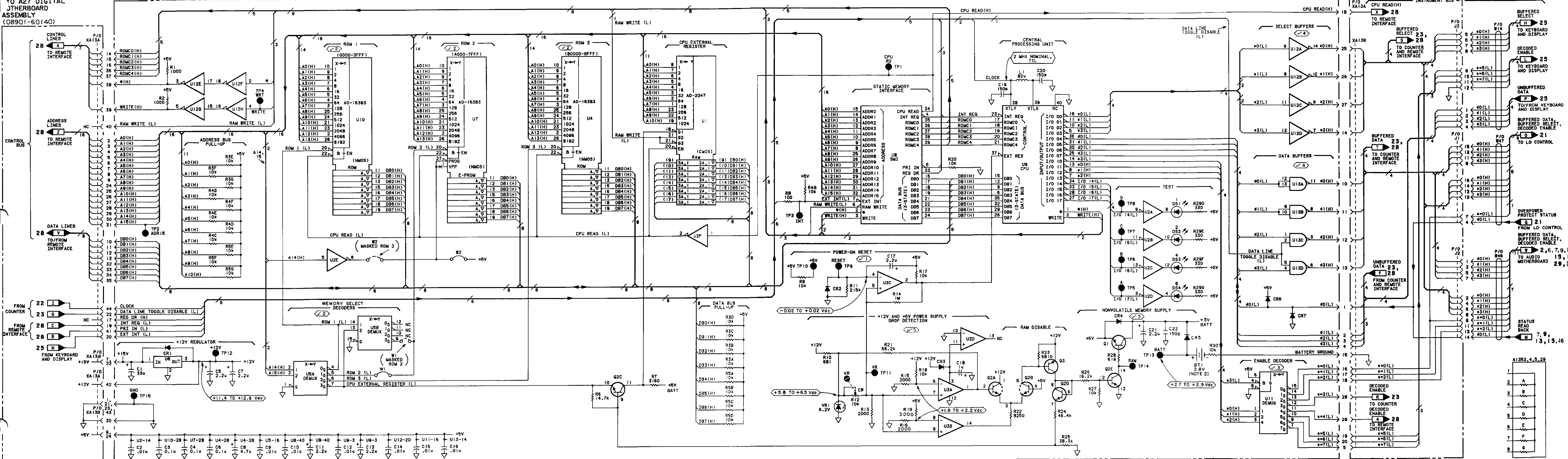

- NOTES**
- SEE TABLE 0A-4 SCHEMATIC DIAGRAM NOTES.
 - WARNING** A13B71 IS A LITHIUM BATTERY. SEE PARAGRAPH 8-7 FOR RECOMMENDED DISPOSAL PROCEDURES.

DIGITAL INTEGRATED CIRCUIT VOLTAGE AND GROUND CONNECTIONS

REFERENCE DESIGNATIONS	VIN	VOUT	PN#
U1	+5V BATT	-24	
U2,13	+5V	-12	
	+5V	-7	
U4,10	+5V	-1,27, 28	
	+5V	-14	
U5,11	+5V	-16	
	+5V	-8	
U7	+5V	-28	
	+5V	-14	
U8	+12V	-40	
	+5V	-1	
U9	+12V	-3	
	+5V	-24	
U12	+5V	-20	
	+5V	-1,10, 18	

A1 Component Coordinates (1 of 3)

COMP	X,Y	COMP	X,Y	COMP	X,Y	COMP	X,Y	COMP	X,Y
C1	A,2	MP25	B,3	S13	C,3				
C2	D,1	MP26	B,2	S14	C,3				
C3	A,2	MP27	D,2	S15	A,2				
C4	B,2	MP28	D,2	S16	A,2				
C5	B,2	MP29	D,3	S17	B,3				
C6	B,2	MP30	D,3	S18	B,2				
C7	C,2	MP31	A,2	S19	C,2				
C8	C,2	MP32	A,2	S20	C,2				
C9	C,2	MP33	C,3	S21	C,3				
C10	D,2	MP34	C,2	S22	C,3				
C11	D,1	MP35	D,2	S23	A,2				
C12	C,2	MP36	D,2	S24	A,2				
C13	B,2	MP37	D,3	S25	B,3				
C14	B,2	MP38	D,3	S26	B,2				
C15	B,2	MP39	A,2	S27	D,2				
C16	C,2	MP40	A,2	S28	D,2				
C17	B,1	MP41	C,3	S29	D,3				
C18	A,1	MP42	C,2	S30	D,3				
C19	D,1	MP43	D,2	S31	A,2				
J1	A,2	MP45	D,3	S33	C,3				
J2	A,1	MP46	D,3	S34	C,2				
				S35	D,2				
MP1	A,3	R1	D,1	S36	D,2				
MP2	A,1	R2	D,2	S37	D,3				
MP3	A,3	R3	D,1	S38	D,3				
MP4	B,3	R4	D,1	S39	A,2				
MP5	B,2	R5	D,1	S40	A,2				
MP6	D,1	R6	D,1	S41	C,3				
MP7	A,2	R7	D,1	S42	C,2				
MP8	A,2	R8	D,1	S43	D,2				
MP9	B,3	R9	D,1	S44	D,2				
MP10	B,2	R10	D,1	S45	D,3				
MP11	C,2	R11	D,1	S46	D,3				
MP12	C,2								
MP13	C,3	S1	A,3	TP1	A,3				
MP14	C,3	S2	A,1	TP2	A,3				
MP15	A,2	S3	A,3	TP3	A,3				
MP16	A,2	S4	B,3	TP4	A,3				
MP17	B,3	S5	B,2	TP5	A,3				
MP18	B,2	S6	D,1	U13	D,1				
MP19	C,2	S7	A,2	U14	D,1				
MP20	C,2	S8	A,2	U19	D,2				
MP21	C,3	S9	B,3	U20	D,2				
MP22	C,3	S10	B,2	U21	D,2				
MP23	A,2	S11	C,2						
MP24	A,2	S12	C,2	W1	A,3				

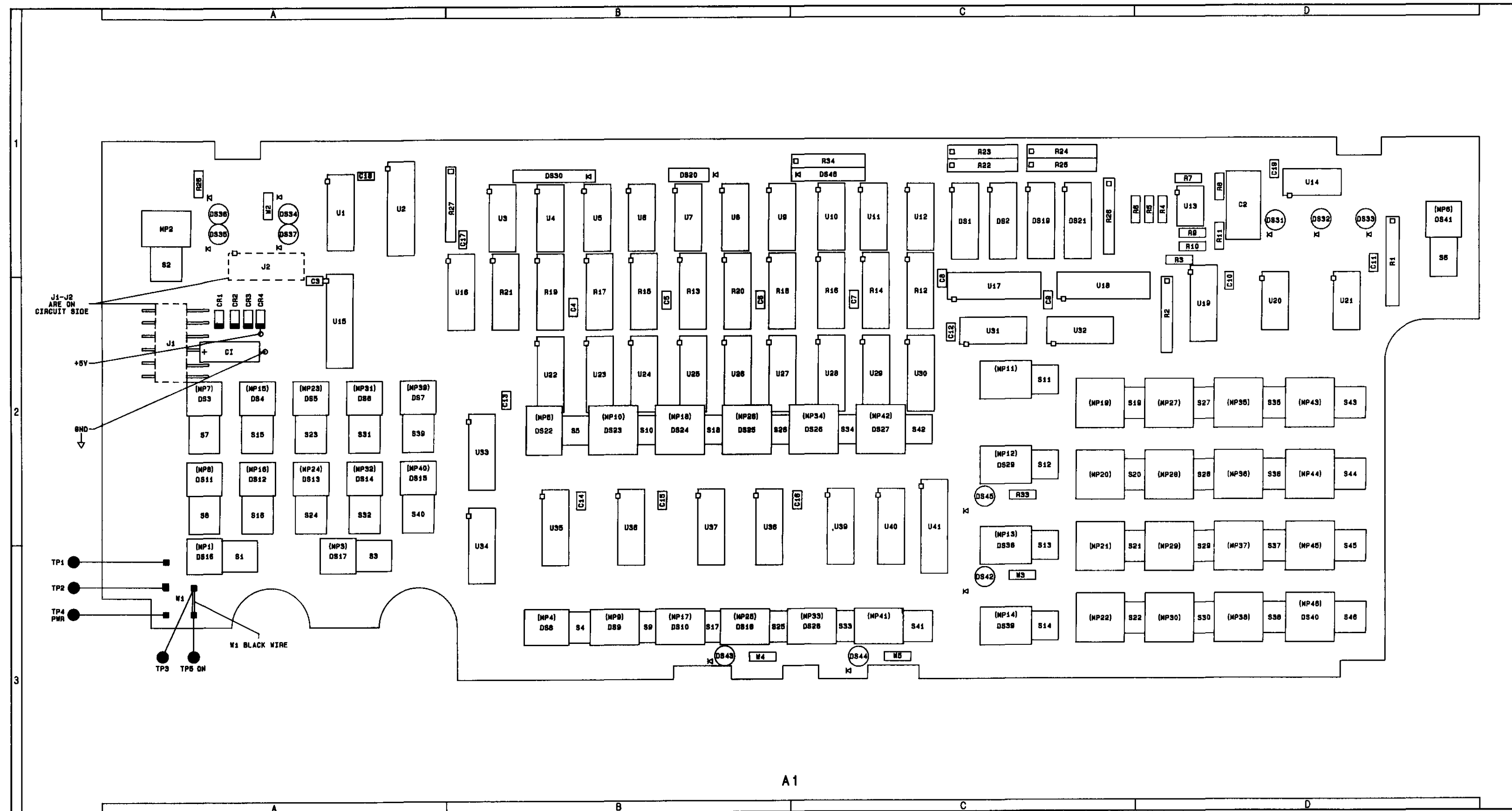

Component Locator

A13 CONTROLLER **SS24**
SEE REVERSE SIDE

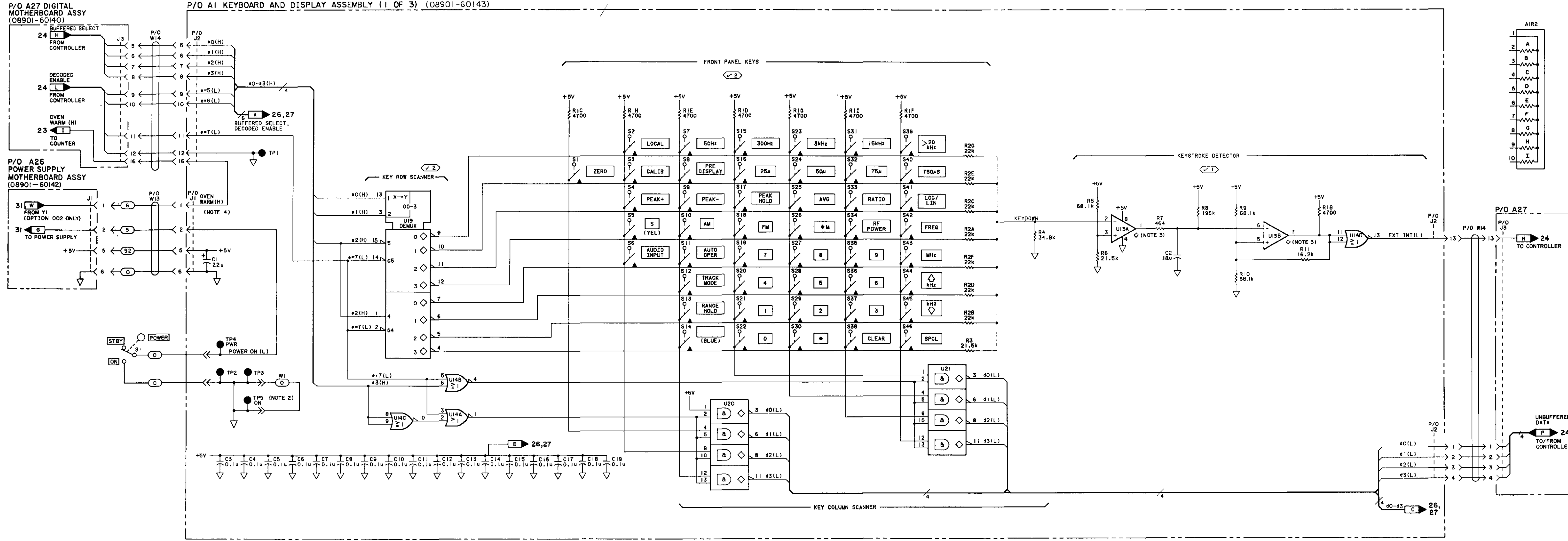

- NOTES
1. SEE TABLE 8A-4 SCHEMATIC DIAGRAM NOTES.
 2. JUMPER A1TP4 TO A1TP3 WITH A1W1 TO TURN ON INSTRUMENT WHEN S3 IS DISCONNECTED.
 3. AMPLIFIERS U13A, B HAVE OPEN-COLLECTOR OUTPUTS.
 4. OPTION 002 OVEN WARM LINE FROM HIGH STABILITY CRYSTAL OSCILLATOR, Y1, CONNECTS THROUGH A26 AND A1 TO A11 COUNTER ASSEMBLY.

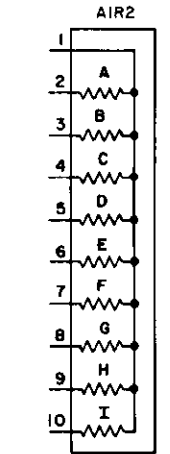

DIGITAL INTEGRATED CIRCUIT VOLTAGE AND GROUND CONNECTIONS

REFERENCE DESIGNATIONS	PIN NUMBERS
U19	+5V - 16 - 8
U14,20,21	+5V - 14 - 7

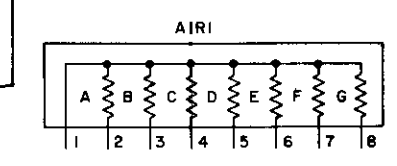

A1 Component Coordinates (2 of 3)

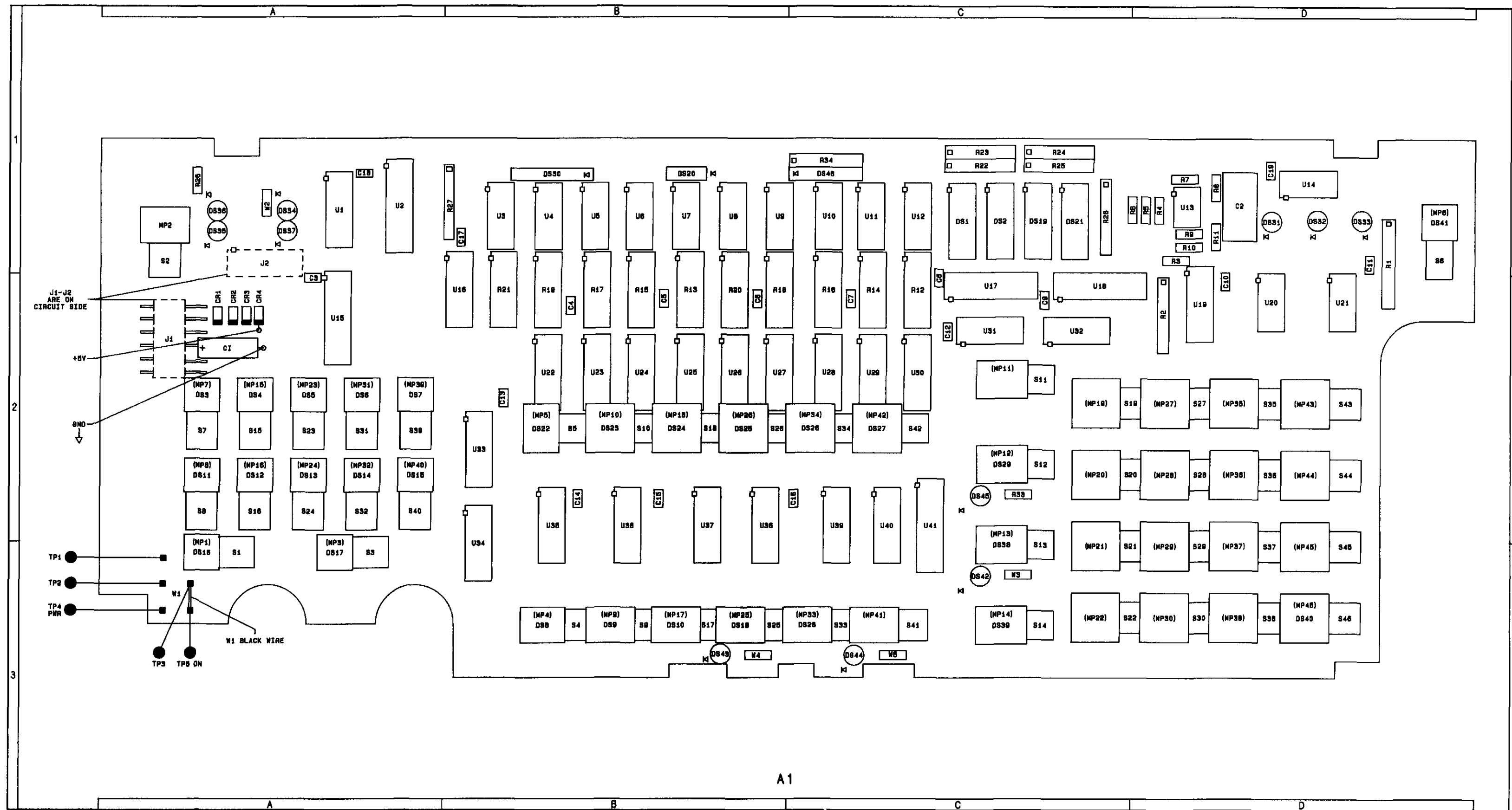

COMP	X,Y	COMP	X,Y	COMP	X,Y	COMP	X,Y	COMP	X,Y
CR1	A,2								
CR2	A,2								
CR3	A,2								
CR4	A,2								
J1	A,2								
J2	A,1								
R12	C,2								
R13	B,2								
R14	C,2								
R15	B,2								
R16	C,2								
R17	B,2								
R18	B,2								
R19	B,2								
R20	B,2								
R21	B,2								
U3	B,1								
U4	B,1								
U5	B,1								
U6	B,1								
U7	B,1								
U8	B,1								
U9	B,1								
U10	C,1								
U11	C,1								
U12	C,1								
U15	A,2								
U16	B,2								
U22	B,2								
U23	B,2								
U24	B,2								
U25	B,2								
U26	B,2								
U27	B,2								
U28	C,2								
U29	C,2								
U30	C,2								
U36	B,2								
U36	B,2								
W1	A,3								

Component Locator

A1 KEYBOARD AND DISPLAY (1 OF 3)
KEYBOARD CIRCUITS

SS25

SEE REVERSE SIDE

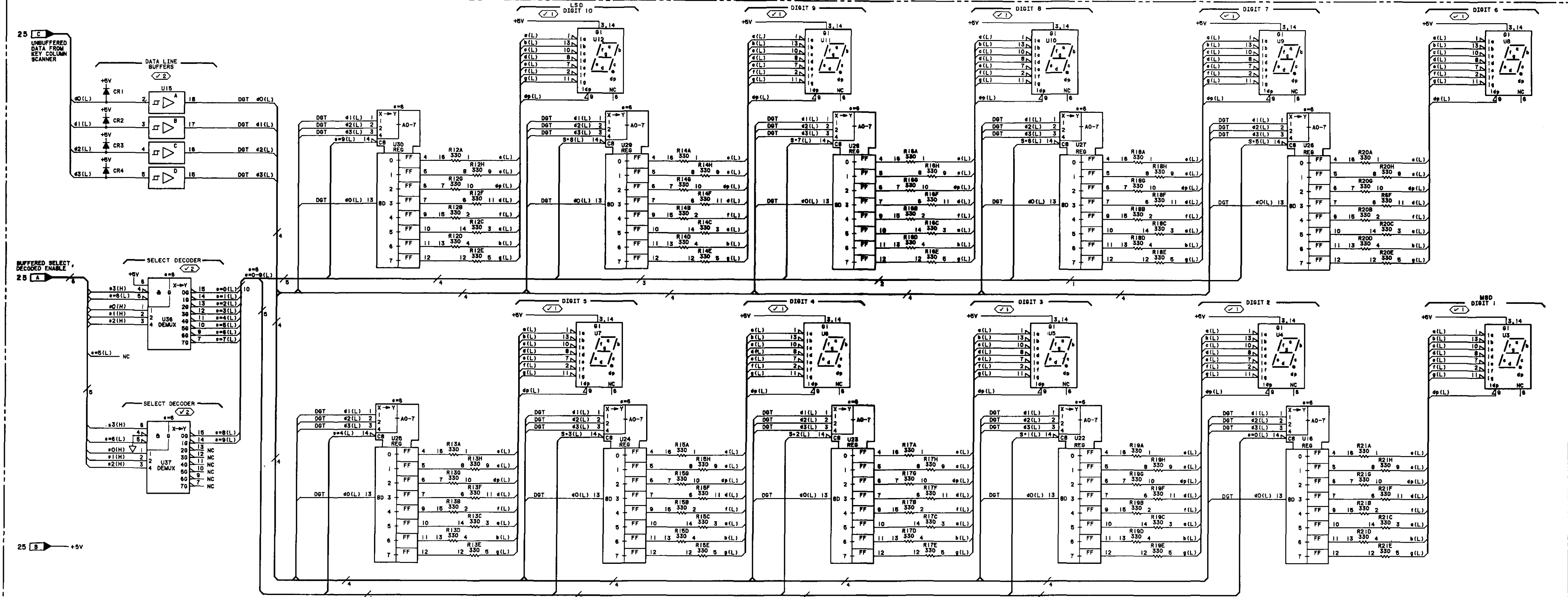

NOTES
1. REFER TO TABLE 8A-4 FOR SCHEMATIC DIAGRAM NOTES.

DIGITAL INTEGRATED CIRCUIT VOLTAGE AND GROUND CONNECTIONS

REFERENCE DESIGNATIONS	PIN NUMBERS
U18, 22-30, 36, 37	+5V - 18, 16 ↓ - 8
U15	+5V - 20 ↓ - 10

A1 Component Coordinates (3 of 3)

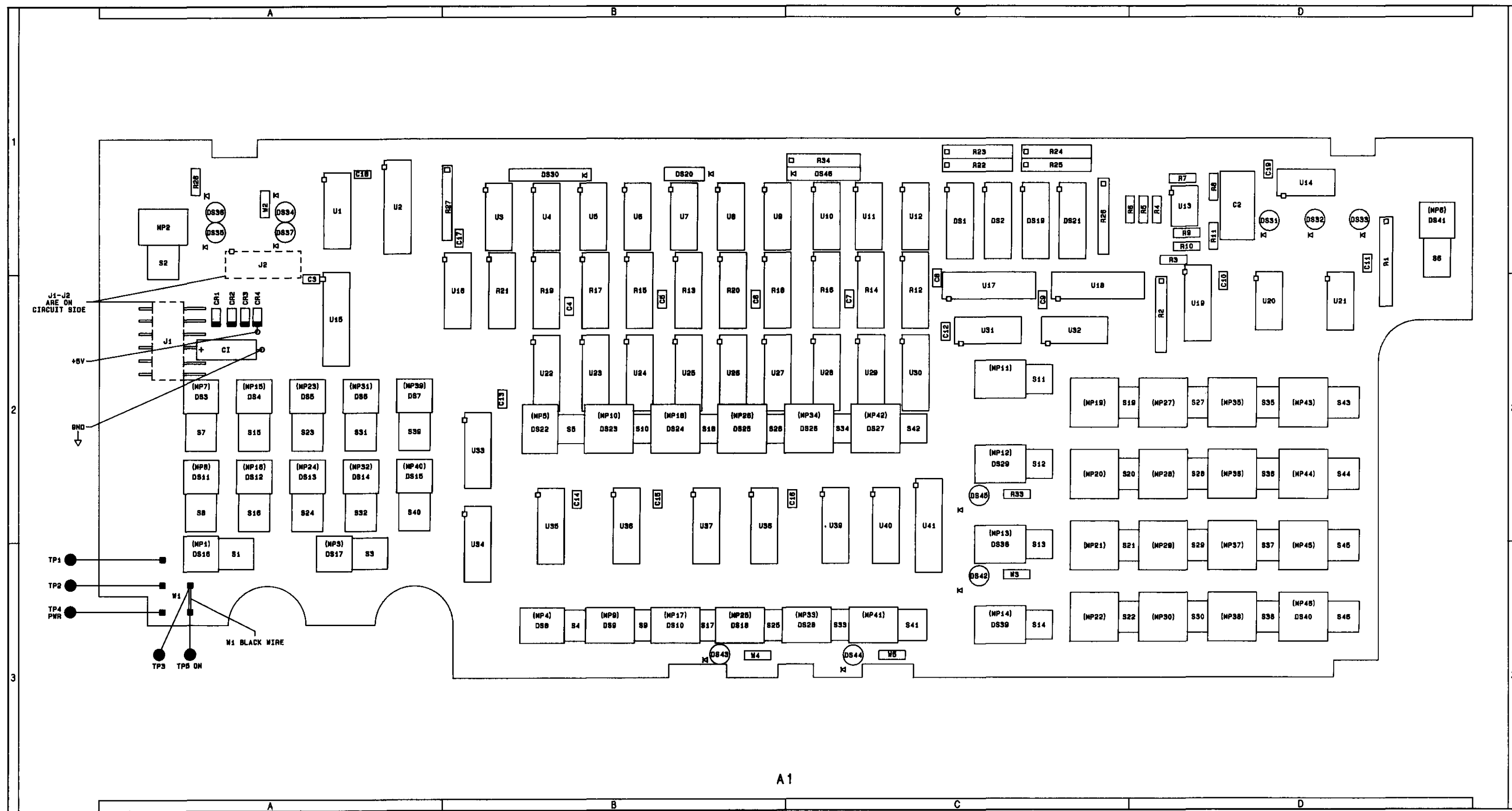

Component Locator

A1 KEYBOARD AND DISPLAY(2 OF 3) DISPLAY CIRCUITS

SS26

SEE REVERSE SIDE

COMP	X,Y	COMP	X,Y	COMP	X,Y	COMP	X,Y	COMP	X,Y
DS1	C,1	J1	A,2						
DS2	C,1	J2	A,1						
DS3	A,2								
DS4	A,2	R22	C,1						
DS5	A,2	R23	C,1						
DS6	A,2	R24	C,1						
DS7	A,2	R25	C,1						
DS8	B,3	R26	A,1						
DS9	B,3	R26	C,1						
DS10	B,3	R27	B,1						
DS11	A,2	R33	C,2						
DS12	A,2	R34	C,1						
DS13	A,2	U1	A,1						
DS14	A,2	U2	A,1						
DS15	A,2	U15	A,2						
DS16	A,3	U15	A,2						
DS17	A,3	U17	C,2						
DS18	B,3	U18	C,2						
DS19	C,1	U31	C,2						
DS20	B,1	U32	C,2						
DS21	C,1	U33	B,2						
DS22	B,2	U34	B,3						
DS23	B,2	U35	B,2						
DS24	B,2	U37	B,2						
DS25	B,2	U39	C,2						
DS26	C,2	U40	C,2						
DS27	C,2	U41	C,2						
DS28	C,3								
DS29	C,2	W2	A,1						
DS30	B,1	W3	C,3						
DS31	D,1	W4	B,3						
DS32	D,1	W5	C,3						
DS33	D,1								
DS34	A,1								
DS35	A,1								
DS36	A,1								
DS37	A,1								
DS38	C,3								
DS39	C,3								
DS40	D,3								
DS41	D,1								
DS42	C,3								
DS43	B,3								
DS44	C,3								
DS45	C,2								
DS46	C,1								

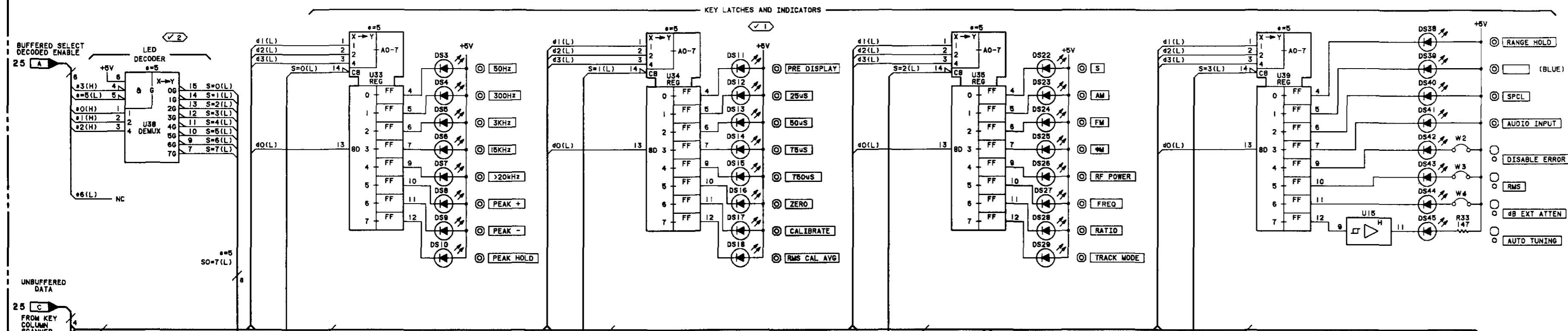

NOTES

1. SEE TABLE 8A-4 SCHEMATIC DIAGRAM NOTES

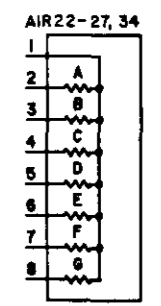

DIGITAL INTEGRATED CIRCUIT VOLTAGE AND PIN CONNECTIONS

REFERENCE DESIGNATIONS	PART NUMBERS
U1, 31-35, 38-40	+5V - 15, 16 ↓ - 8
U2, 15, 18, 41	+5V - 20 ↓ - 10

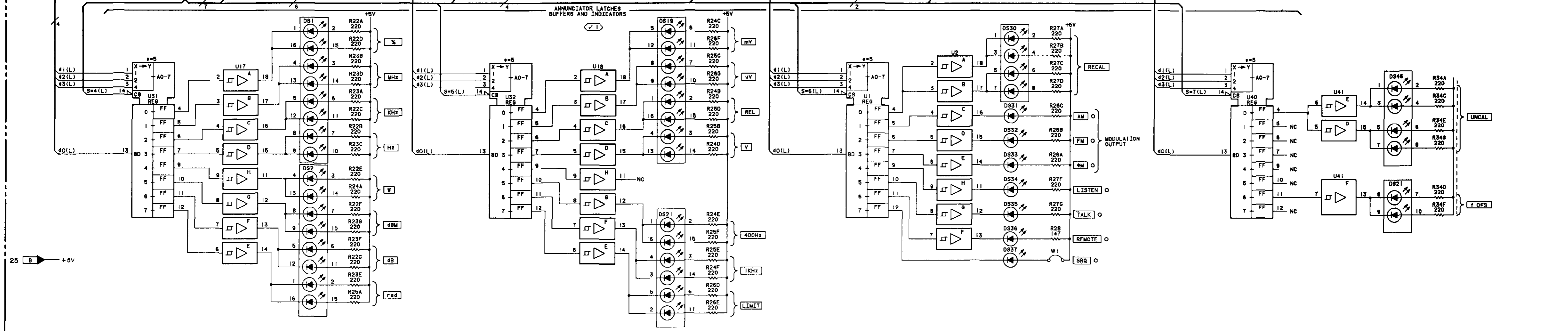

A14 Component Coordinates

COMP	X,Y	COMP	X,Y	COMP	X,Y	COMP	X,Y	COMP	X,Y
C1	B,3	TP8	B,1						
C2	A,2	TP9	B,1						
C3	A,1								
C4	A,1	U1	A,1						
C5	A,2	U2	A,1						
C6	A,2	U3	B,1						
C7	A,2	U4	A,2						
C8	A,2	U5	A,2						
C9	A,1	U6	A,2						
C10	B,2	U7	A,2						
C11	B,2	U8	B,2						
C12	B,2	U9	B,2						
C13	B,2	U10	B,2						
C14	B,2	U11	B,2						
C15	B,2	U12	A,2						
C16	B,2	U13	A,2						
C17	B,2	U15	B,2						
C18	B,3	U16	B,2						
		U17	B,2						
CR1	A,2	U19	B,2						
		U20	B,2						
J1	A,1	U21	B,2						
		U22	B,2						
MP1	A,1								
MP2	B,1	VR1	B,3						
R1	B,3								
R2	A,2								
R3	B,1								
R4	B,2								
R5	B,2								
R6	B,2								
R7	A,2								
R8	B,2								
R9	A,2								
S1	B,1								
TP1	B,1								
TP2	B,1								
TP3	B,1								
TP4	B,1								
TP5	B,1								
TP6	B,1								
TP7	B,1								

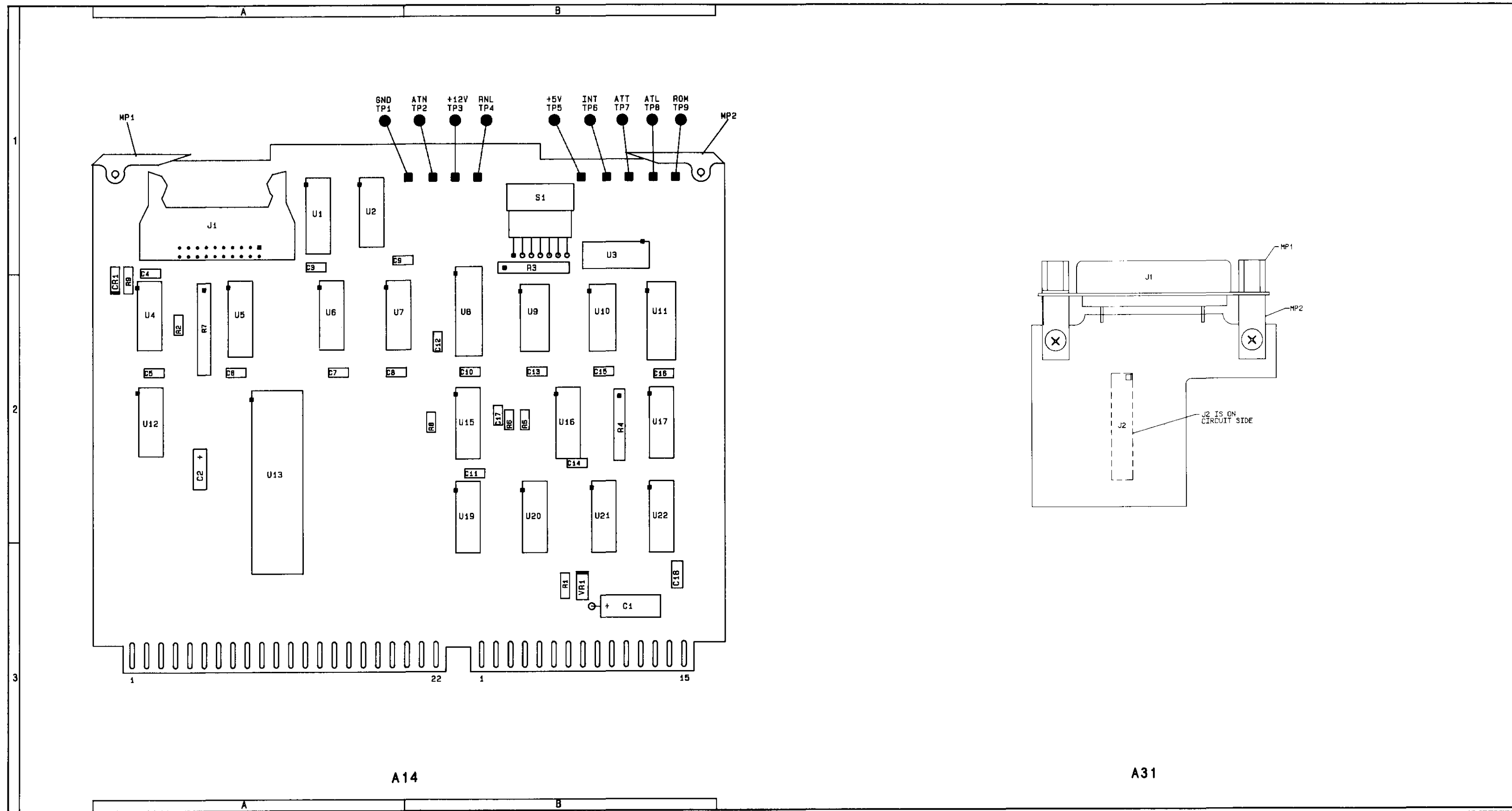

Component Locators

A1 KEYBOARD AND DISPLAY (3 OF 3) ANNUNCIATOR CIRCUITS **SS27**
SEE REVERSE SIDE

CHANGES

3019A and above

On the A14 Schematic:

- R5 - Under INTERFACE CONTROL, change the value of R5 to 2150 Ω .

P/O A27 DIGITAL MOTHERBOARD ASSEMBLY (08901-60140)

A14 REMOTE INTERFACE ASSEMBLY (08901-60223)

P/O A30

A31 REMOTE INTERFACE CONNECTOR ASSEMBLY (08901-60242)

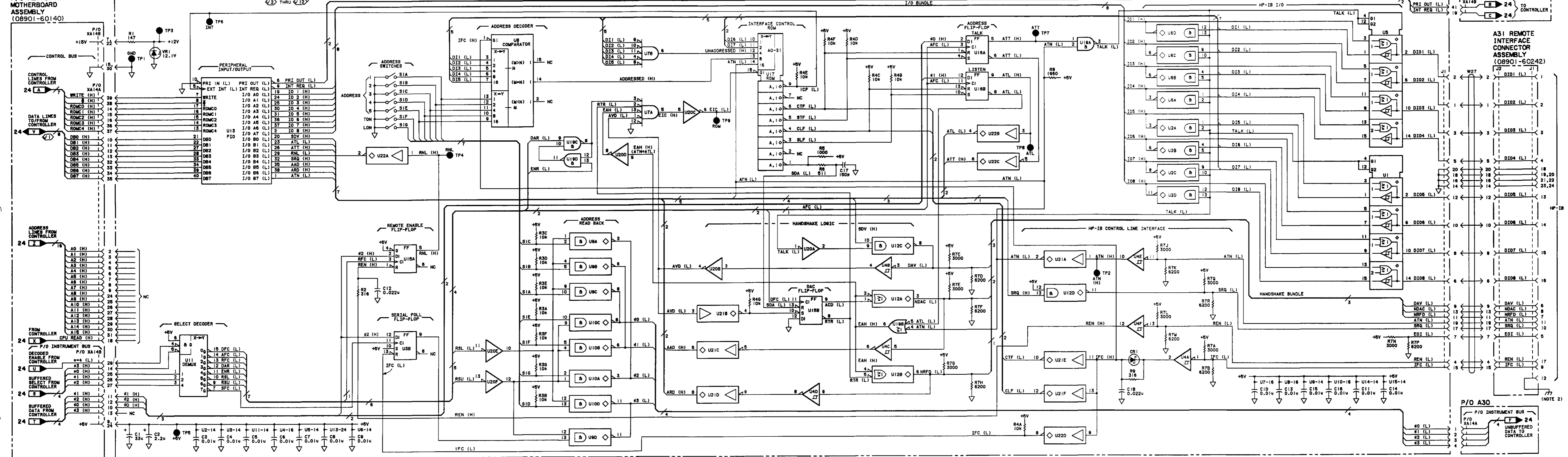

- NOTES
- SEE TABLE 8A-4 FOR SCHEMATIC DIAGRAM NOTES.
 - CHASSIS GROUND IS ACHIEVED BY MECHANICAL CONTACT THRU SCREWS HOLDING P.C. BOARD TO FRAME.

DIGITAL INTEGRATED CIRCUIT VOLTAGE AND GROUND CONNECTIONS

REFERENCE DESIGNATIONS	V PIN NUMBERS
U1, 5, 8, 11, 17, 18	+5V - 16
	△ - 8
U2-4, 6, 7, 9, 10, 12, 15, 16, 18-22	+5V - 14
	△ - 7
U13	+12V - 3
	△ - 18
U14	+5V - 24
	△ - 12

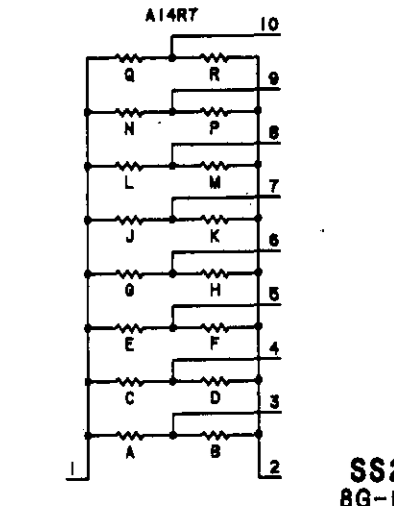

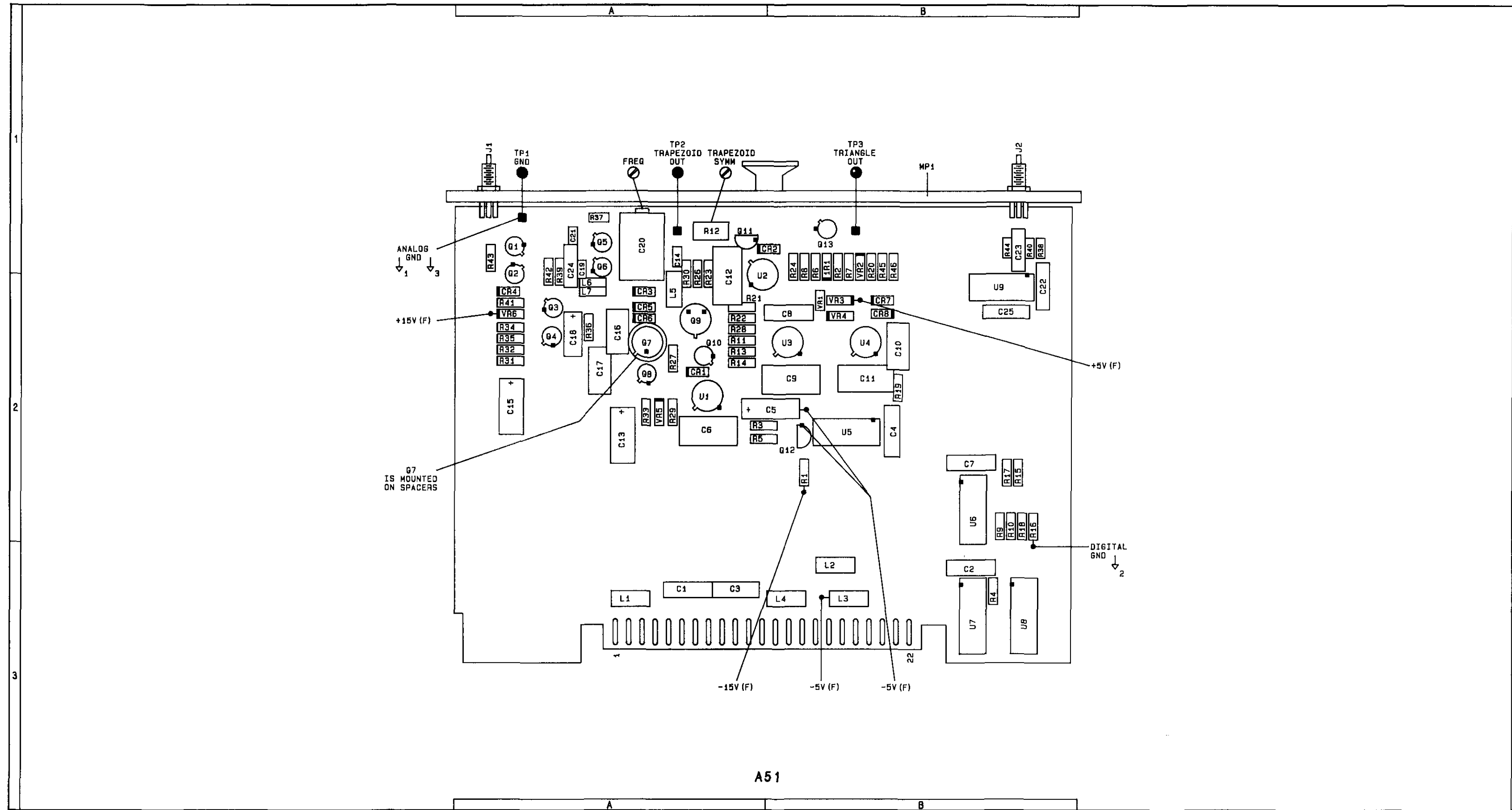

A51
Component Locator

A14 REMOTE INTERFACE
A31 REMOTE INTERFACE CONNECTOR (HP-1B) **SS28**
SEE REVERSE SIDE

A51 Component Coordinates

COMP	X,Y	COMP	X,Y	COMP	X,Y	COMP	X,Y	COMP	X,Y
C1	A,3	MP1	B,1	R30	A,1				
C2	B,3			R31	A,2				
C3	A,3	Q1	A,1	R32	A,2				
C4	B,2	Q2	A,1	R33	A,2				
C5	B,2	Q3	A,2	R34	A,2				
C6	A,2	Q4	A,2	R35	A,2				
C7	B,2	Q5	A,1	R36	A,2				
C8	B,2	Q6	A,1	R37	A,1				
C9	B,2	Q7	A,2	R38	B,1				
C10	B,2	Q8	A,2	R39	A,1				
C11	B,2	Q9	A,2	R40	B,1				
C12	A,1	Q10	A,2	R41	A,2				
C13	A,2	Q11	A,1	R42	A,1				
C14	A,1	Q12	B,2	R43	A,1				
C15	A,2	Q13	B,1	R44	B,1				
C16	A,2			R45	B,1				
C17	A,2	R1	B,2	R46	B,1				
C18	A,2	R2	B,1						
C19	A,1	R3	A,2	TP1	A,1				
C20	A,1	R4	B,1	TP2	A,1				
C21	A,1	R4	B,3	TP3	B,1				
C22	B,2	R5	A,2						
C23	B,1	R6	B,1	U1	A,2				
C24	A,1	R7	B,1	U2	A,1				
C25	B,2	R8	B,1	U3	B,2				
		R9	B,2	U4	B,2				
CR1	A,2	R10	B,2	U5	B,2				
CR2	A,1	R11	A,2	U6	B,2				
CR3	A,2	R12	A,1	U7	B,3				
CR4	A,2	R13	A,2	U8	B,3				
CR5	A,2	R14	A,2	U9	B,2				
CR6	A,2	R15	B,2						
CR7	B,2	R16	B,2	VR1	B,1				
CR8	B,2	R17	B,2	VR2	B,1				
		R18	B,2	VR3	B,2				
J1	A,1	R19	B,2	VR4	B,2				
J2	B,1	R20	B,1	VR5	A,2				
		R21	A,2	VR6	A,2				
L1	A,3	R22	A,2						
L2	B,3	R23	A,1						
L3	B,3	R24	B,1						
L4	B,3	R26	A,1						
L5	A,2	R27	A,2						
L6	A,2	R28	A,2						
L7	A,2	R29	A,2						

P/O A25 AUDIO MOTHERBOARD ASSEMBLY (08902-60137)

A51 FM CALIBRATOR ASSEMBLY (08901-60013)

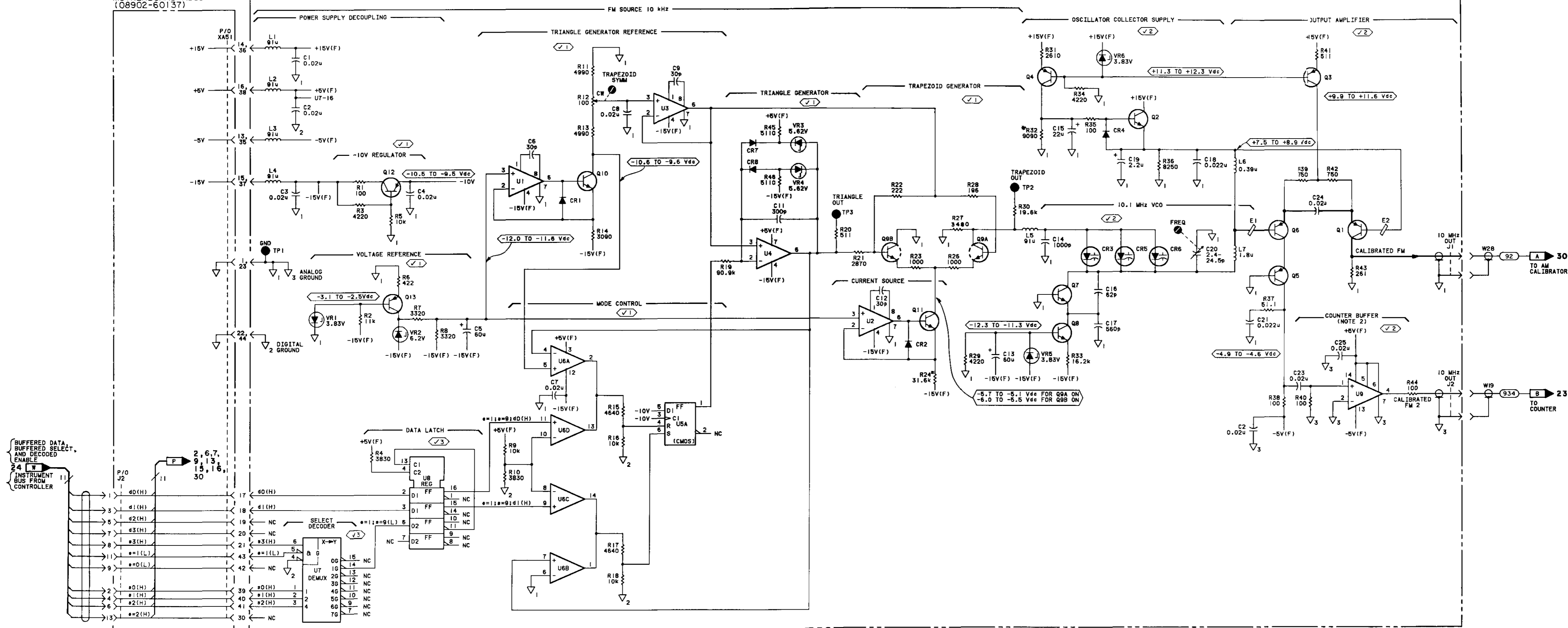

- NOTES
 1. SEE TABLE 8A-4 SCHEMATIC DIAGRAM NOTES.
 2. THE COUNTER BUFFER IS REFERENCED TO THE COUNTER GROUND THROUGH THE SHIELD OF W19.

DIGITAL INTEGRATED CIRCUIT VOLTAGE AND GROUND CONNECTIONS

REFERENCE DESIGNATIONS	PIN NUMBERS
U5	-10V - 7 ↓ 1 - 14
U7	+5V(F) - 16 ↓ 2 - 8
U8	+5V(F) - 5 ↓ 2 - 12

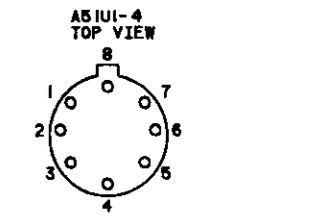

A50 Component Coordinates

COMP	X,Y	COMP	X,Y	COMP	X,Y	COMP	X,Y	COMP	X,Y	COMP	X,Y
C1	B,3	C47	B,2	Q11	A,2	R32	A,1	R77	B,1	U8	B,2
C2	A,3	C48	A,2	Q12	A,2	R33	A,2	R78	B,2	U9	B,2
C3	B,3	C49	A,2	Q13	A,2	R34	A,2	R79	A,2	U10	B,3
C4	A,3	C50	B,2	Q14	B,2	R35	A,2	R80	B,2		
C5	A,1	C51	B,2	Q15	B,2	R36	B,2	R81	A,2	VR1	B,2
C6	A,2	C52	A,3	Q16	B,2	R37	A,2	R82	A,2	VR2	B,2
C7	A,2	C53	A,2	Q17	B,2	R38	A,2	R83	A,3	VR3	B,2
C8	A,2	C54	B,2	Q18	B,2	R39	A,1	R84	B,2		
C9	A,3			Q19	B,2	R40	B,2	R85	A,2		
C10	A,1	CR1	A,1	Q20	B,2	R41	A,2	R86	A,2		
C11	A,2	CR2	A,2	Q21	A,3	R42	A,1	R87	B,2		
C12	A,2	CR3	B,1	Q22	A,3	R43	A,2	R88	A,2		
C13	A,2	CR4	B,2	Q23	A,3	R44	A,2	R89	B,2		
C14	A,1	CR5	B,1			R45	B,1	R90	A,2		
C15	A,2	CR6	B,2	R1	B,3	R46	A,2	R91	B,2		
C16	A,2	CR7	B,1	R2	B,3	R47	B,2	R92	A,2		
C17	A,1	CR8	B,2	R3	B,3	R48	B,1	R93	A,2		
C18	A,1	CR9	A,2	R4	A,3	R49	B,2	R94	B,2		
C19	A,2	CR10	A,2	R5	B,2	R50	A,3	R95	B,2		
C20	A,2	CR11	B,2	R6	B,2	R51	B,1	R96	B,2		
C22	A,2	CR12	B,2	R7	A,3	R52	B,2	R97	B,2		
C23	B,1			R8	A,3	R53	A,2	R98	B,2		
C24	B,2	J1	A,1	R9	A,3	R54	B,1	R99	B,2		
C25	B,1	J2	A,1	R10	B,2	R55	B,1	R100	B,2		
C26	B,2			R11	B,3	R56	B,1	R101	B,2		
C27	B,2	L1	B,3	R12	A,1	R57	B,2	R102	A,2		
C28	B,2	L2	B,3	R13	A,1	R58	B,2	R103	A,2		
C29	B,2	L3	A,1	R14	A,1	R59	B,2	R104	B,2		
C30	A,2	L3	B,3	R15	A,2	R60	B,2	R105	B,2		
C31	B,1	L4	A,2	R16	A,2	R61	B,1	R106	B,2		
C32	B,2	L5	A,2	R17	A,2	R62	B,2	R107	A,2		
C33	B,2	L6	A,2	R18	B,2	R63	A,2	R108	A,2		
C34	A,2	L7	B,2	R19	B,2	R64	A,2	R109	A,2		
C35	B,2	L8	B,2	R20	A,3	R65	B,2				
C36	A,2			R21	A,3	R66	B,2	TP1	A,1		
C37	A,2	Q1	A,2	R22	A,2	R67	A,2	TP2	A,1		
C38	B,2	Q2	A,2	R23	A,1	R68	B,2	TP3	B,1		
C39	B,2	Q3	A,1	R24	A,2	R69	B,1				
C40	B,2	Q4	A,2	R25	A,1	R70	B,2	U1	A,2		
C41	A,2	Q5	B,2	R26	A,2	R71	B,1	U2	A,2		
C42	A,2	Q6	A,2	R27	A,2	R72	A,2	U3	B,2		
C43	A,2	Q7	A,2	R28	A,2	R73	B,2	U4	A,2		
C44	B,2	Q8	A,2	R29	A,2	R74	B,2	U5	A,2		
C45	A,2	Q9	A,2	R30	A,1	R75	B,2	U6	A,2		
C46	A,2	Q10	A,2	R31	A,1	R76	B,2	U7	A,2		

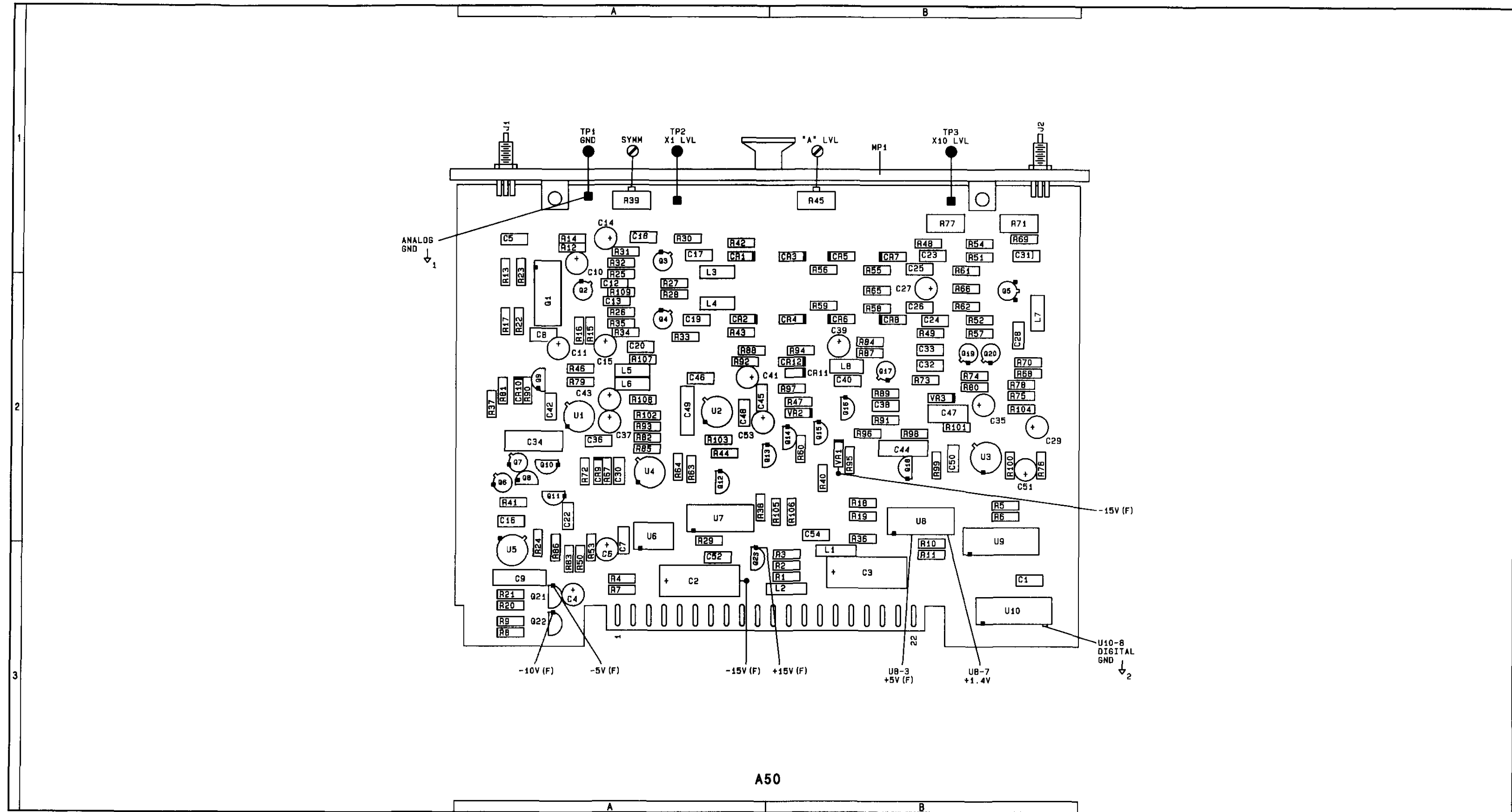

Component Locator

A51 FM CALIBRATOR

SS29

SEE REVERSE SIDE

A50 AM CALIBRATOR ASSEMBLY (08901-60220)

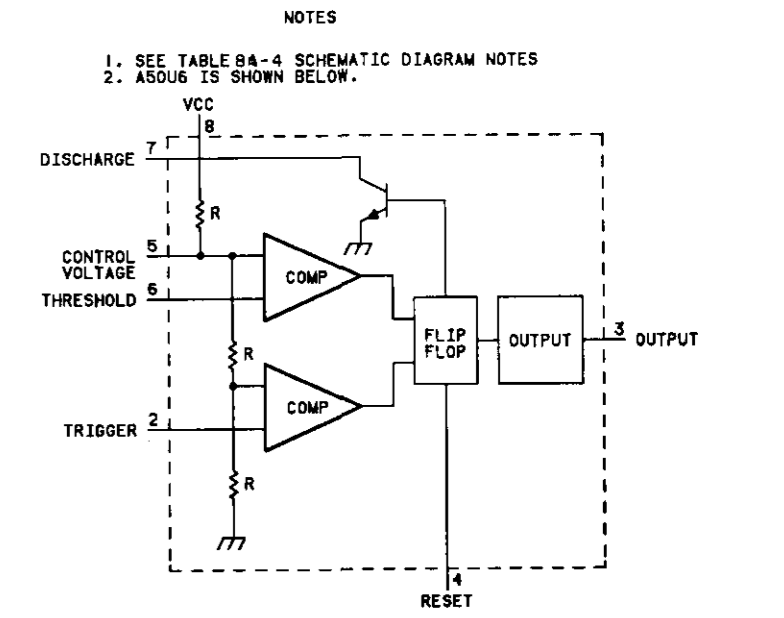
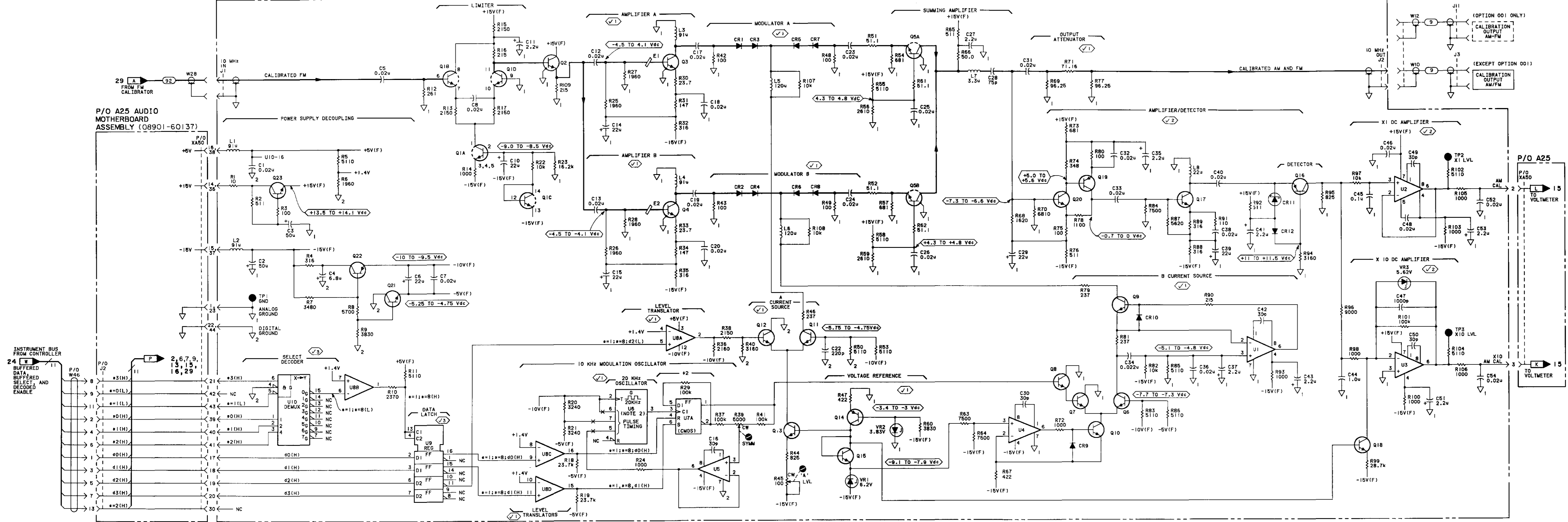

DIGITAL INTEGRATED CIRCUIT VOLTAGE AND GROUND CONNECTIONS

REFERENCE DESIGNATIONS	PIN NUMBERS
U6	-5V(F) - 8
	-15V(F) - 1
U7	-5V(F) - 14
	-10V(F) - 7
U8	+5V(F) - 5
	-12 - 12
U10	+5V(F) - 18
	-12 - 8

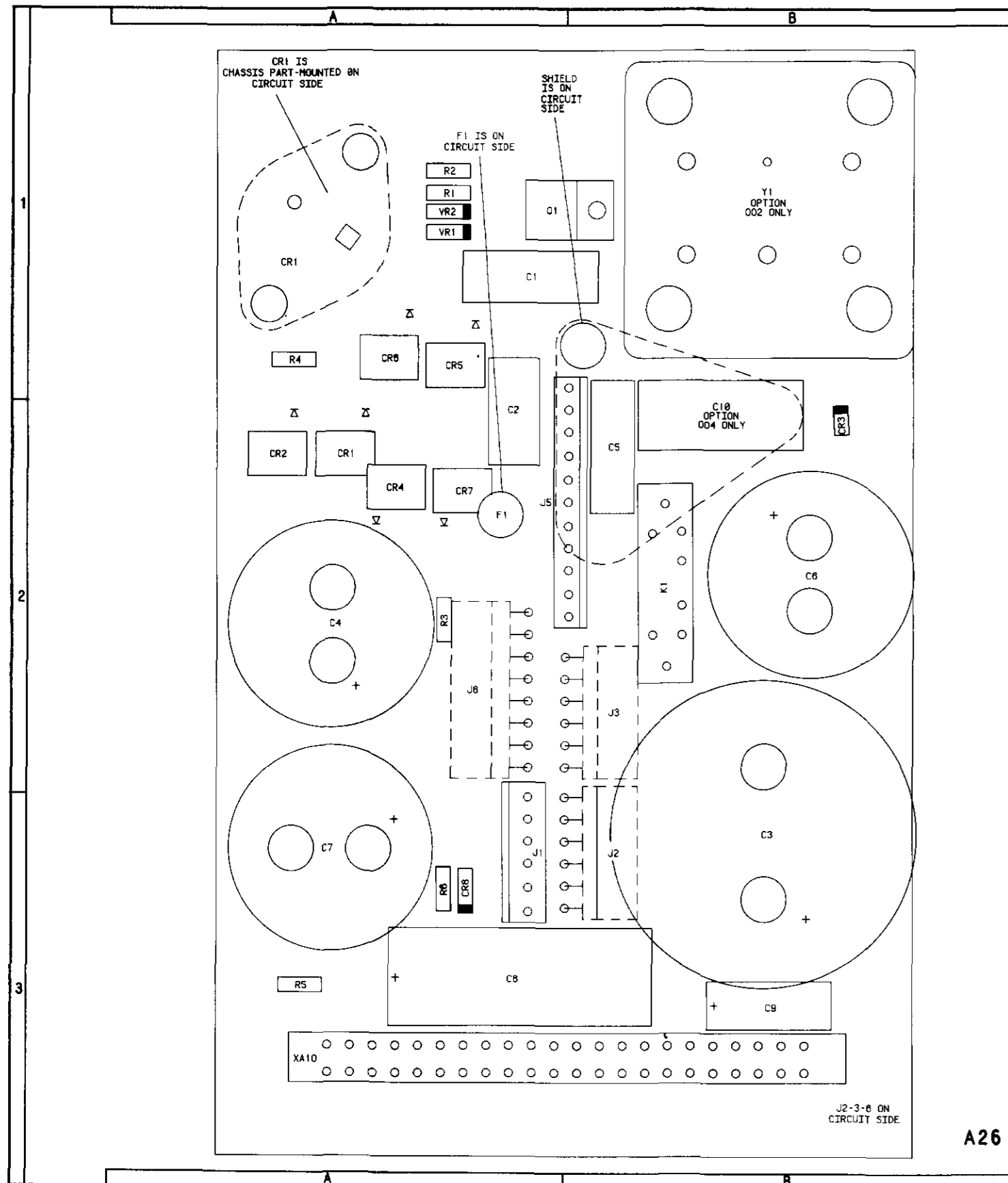

A26

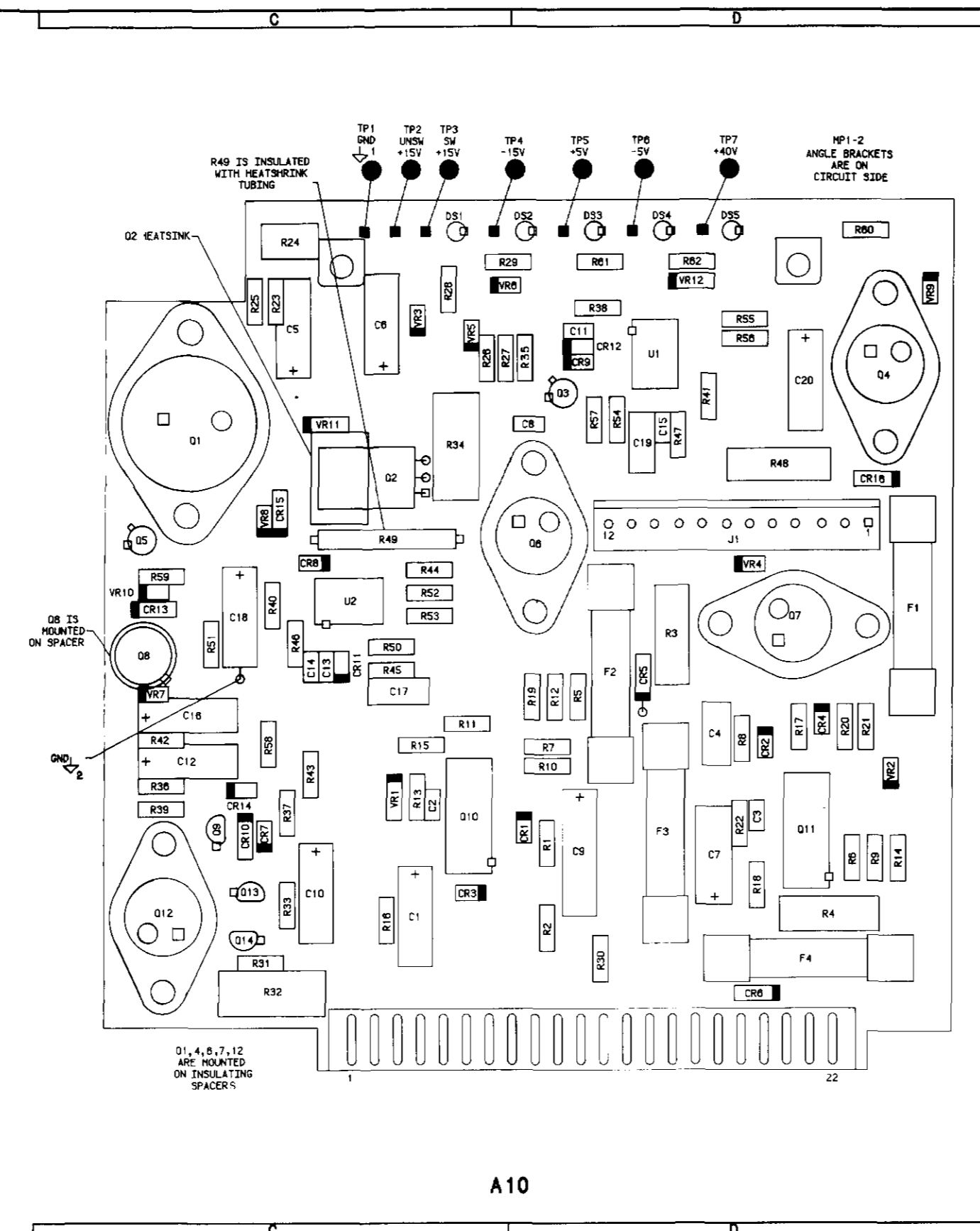

A10

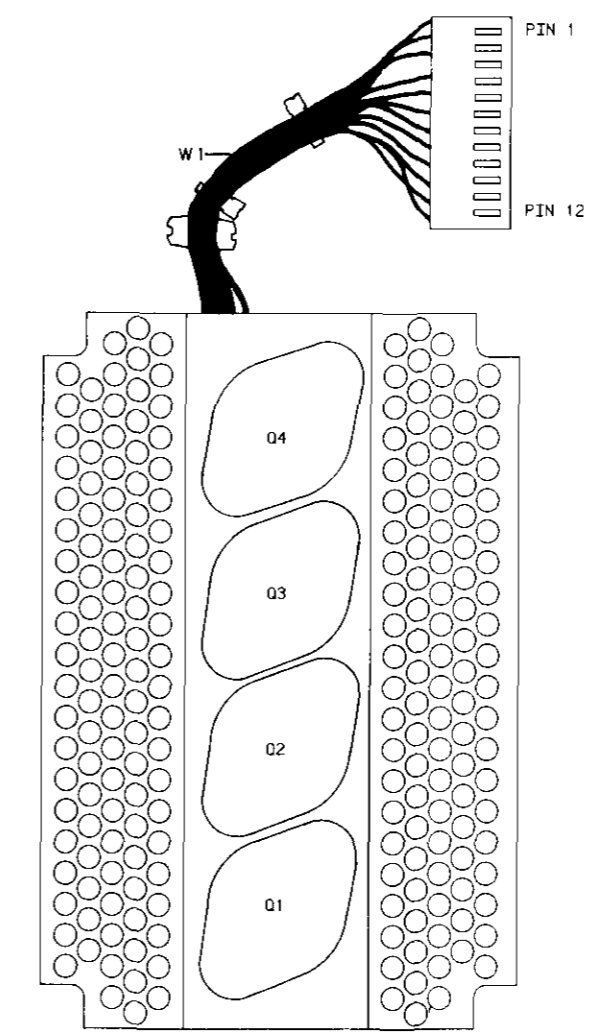

A29

Component Locators

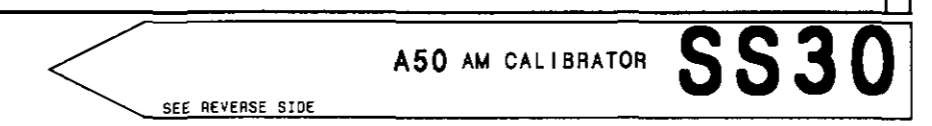

A10		COMP	X,Y	A26		COMP	X,Y
C1	C,3	R18	D,3	C1	A,1		
C2	C,2	R19	D,2	C2	A,2		
C3	D,2	R20	D,2	C3	B,3		
C4	D,2	R21	D,2	C4	A,2		
C5	C,1	R22	D,3	C5	B,2		
C6	C,1	R23	C,1	C6	B,2		
C7	D,3	R24	C,1	C7	A,3		
C8	D,2	R25	C,1	C8	B,2		
C9	D,3	R26	C,1	C9	B,2		
		R27	C,1				
		R28	C,1	CR1	A,1		
CR1	D,3	R29	D,1	CR1	A,2		
CR2	D,2	R30	D,3	CR2	A,2		
CR3	C,3			CR3	B,2		
CR4	D,2	TP1	C,1	CR4	A,2		
CR5	D,2	TP2	C,1	CR5	A,1		
CR6	D,3	TP3	C,1	CR6	A,1		
		TP4	C,1	CR7	A,2		
DS1	C,1						
DS2	D,1	VR1	C,2	J1	A,3		
		VR2	D,2	J2	B,3		
F3	D,3	VR3	C,1	J3	B,2		
F4	D,3	VR4	D,2	J5	A,2		
		VR5	C,1	J6	A,2		
J1	D,2	VR6	D,1				
				K	1B,2		
Q6	D,2						
Q7	D,2			Q1	A,1		
Q10	C,2						
Q11	D,3			R1	A,1		
				R2	A,1		
R1	D,3			R3	A,2		
R2	D,3			R4	A,1		
R3	D,2			R5	A,3		
R4	D,3						
R5	D,2			VR1	A,1		
R6	D,3			VR2	A,1		
R7	D,2						
R8	D,2			XA10	A,3		
R9	D,3						
R10	D,2			Y1	B,1		
R11	C,2						
R12	D,2						
R13	C,2						
R14	D,3						
R15	C,2						
R16	C,3						
R17	D,2						

CHANGES

<p>2517A and Above</p>	<p>A10 Component Coordinates:</p> <ul style="list-style-type: none"> • Use the A10 Component Coordinates on page 8G-68.3. <p>A10 Component Locator:</p> <ul style="list-style-type: none"> • Use the A10 Component Locator on page 8G-68.4. <p>On the Schematic:</p> <ul style="list-style-type: none"> • A10 - Change the part number of A10 power supply Regulators Assembly to 08901-60269.
<p>2806A and Above</p>	<p>On the A26 Schematic:</p> <ul style="list-style-type: none"> • In the upper left portion of SS31, change the P/O A26 POWER SUPPLY MOTHERBOARD ASSEMBLY board part number to 08901-60295. • ON/STAND-BY RELAY - In the upper left portion of SS31 under P/O A26 POWER SUPPLY MOTHERBOARD ASSEMBLY locate ON/STAND-BY RELAY and change pin 1 to pin 13. Below the relay, locate P/O K1 and change pin 5 to 4, and pin 4 to 5. • (NOTE 4) P/O K1 - On the right hand side of SS31 under P/O A26, locate (NOTE 4) P/O K1 and change pin 8 to 12 and pin 6 to 11.

This page reserved for future changes.

A10 Component Coordinates (2517A and Above)

COMP	X,Y	COMP	X,Y	COMP	X,Y	COMP	X,Y	COMP	X,Y
C1	A,2	R17	B,2						
C2	A,2	R18	B,2						
C3	B,2	R19	A,2						
C4	B,3	R20	B,2						
C5	A,1	R21	B,2						
C6	A,1	R22	B,3						
C7	B,2	R23	A,1						
C8	A,1	R24	A,1						
C9	B,3	R25	A,1						
		R26	A,1						
CR1	A,2	R27	A,1						
CR2	B,2	R28	A,1						
CR3	A,3	R29	A,1						
CR4	B,2	R30	B,3						
CR5	B,3								
CR6	B,3	TP1	A,1						
		TP2	A,1						
DS1	A,1	TP3	A,1						
DS2	A,1	TP4	A,1						
F3	B,2	VR1	A,2						
F4	B,2	VR2	B,2						
		VR3	A,1						
J1	B,2	VR4	B,2						
		VR5	A,1						
Q6	A,2	VR6	A,1						
Q7	B,2								
Q8	A,2								
Q10	A,2								
Q11	B,3								
R1	A,2								
R2	A,2								
R3	B,2								
R4	B,3								
R5	A,2								
R6	B,2								
R7	A,2								
R8	B,2								
R9	B,2								
R10	A,2								
R11	A,2								
R12	A,2								
R13	A,2								
R14	B,2								
R15	A,2								
R16	A,3								

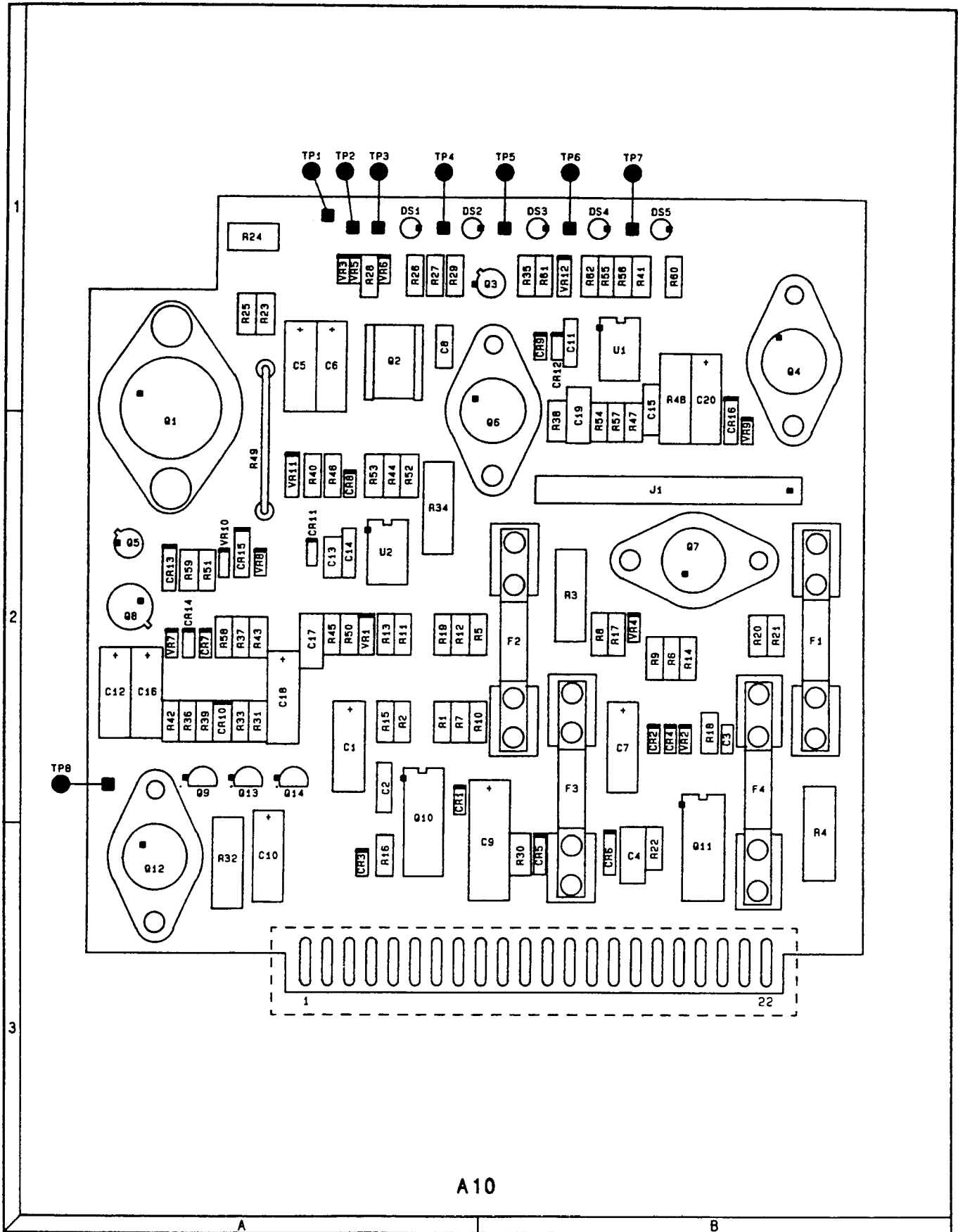

A10 Component Locator
(2517A and Above)

DANGER HAZARDOUS VOLTAGE

WARNINGS

MAINS VOLTAGE IS PRESENT AT THE LINE POWER MODULE WHENEVER THE POWER CABLE IS CONNECTED. IN ADDITION, APPROXIMATELY 117 Vrms IS PRESENT AT THE CONTACTS OF THE PLUG MATING WITH A26J5A AND B AND AT A26J5A AND B ITSELF WHENEVER THE POWER CABLE IS CONNECTED. BE EXTREMELY CAREFUL WHEN WORKING IN PROXIMITY TO THESE AREAS. THESE HAZARDOUS VOLTAGES COULD CAUSE SERIOUS PERSONAL INJURY IF CONTACTED.

WHENEVER THE POWER CABLE IS CONNECTED, APPROXIMATELY 50 Vrms IS ACCESSIBLE AT THE SECONDARY OF T1, AND WHEN T1 IS CONNECTED, AT A26XA10 PIN 42. BE EXTREMELY CAREFUL WHEN WORKING IN PROXIMITY TO THESE AREAS.

P/O A1 KEYBOARD AND DISPLAY ASSEMBLY (08901-60143)

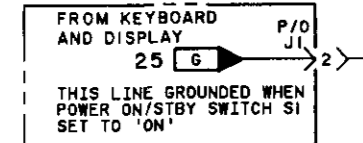

A30 LINE POWER ASSEMBLY (0960-0443)

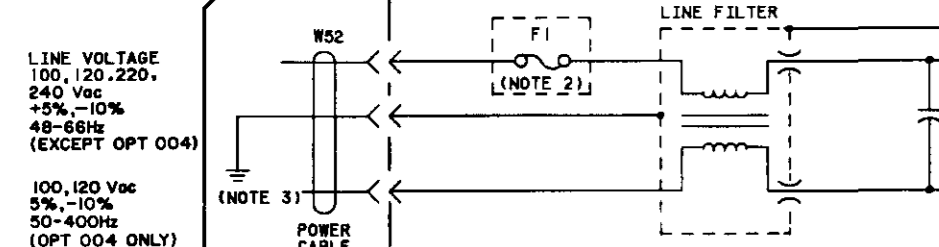

P/O A26 POWER SUPPLY MOTHERBOARD ASSEMBLY (08901-60142)

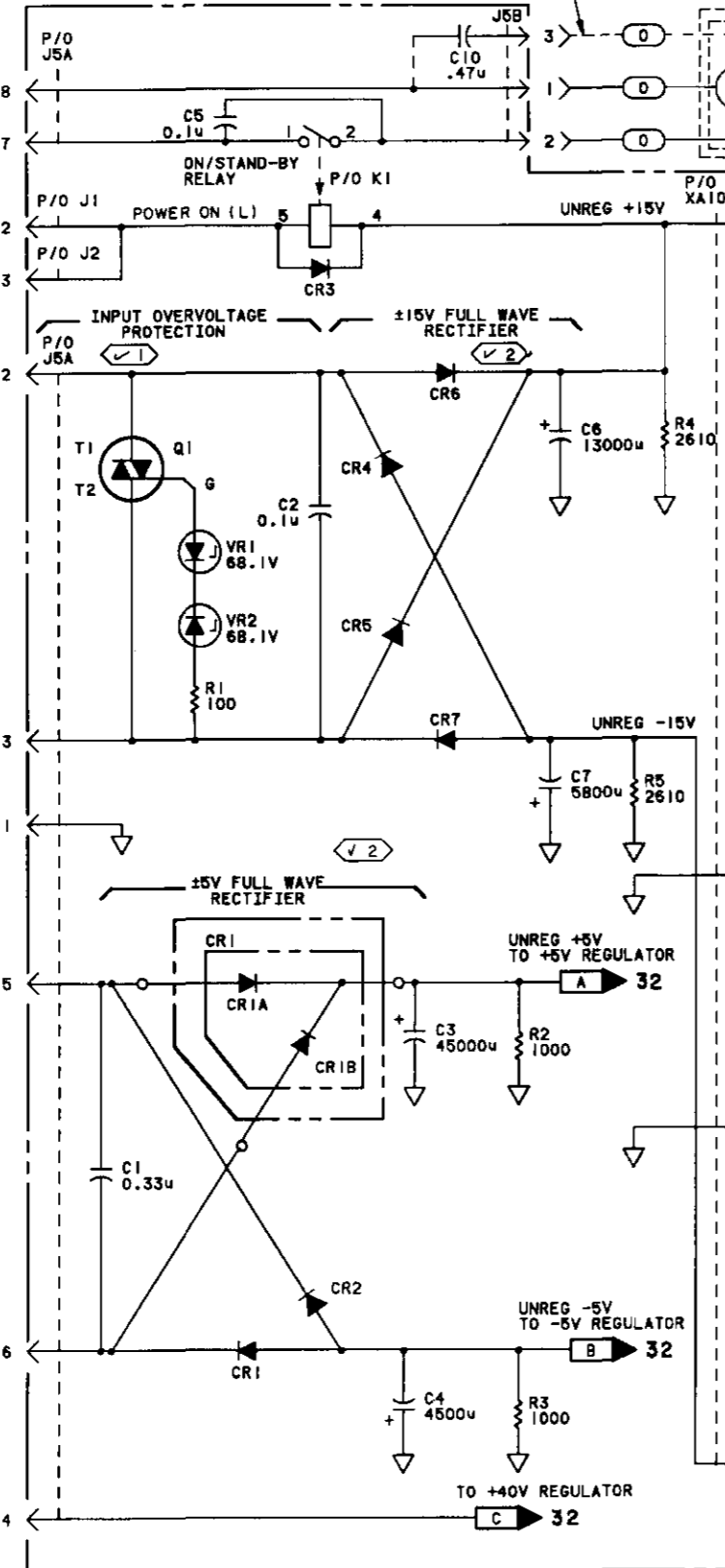

P/O A10 POWER SUPPLY REGULATORS ASSEMBLY (1 OF 2) (08901-60141)

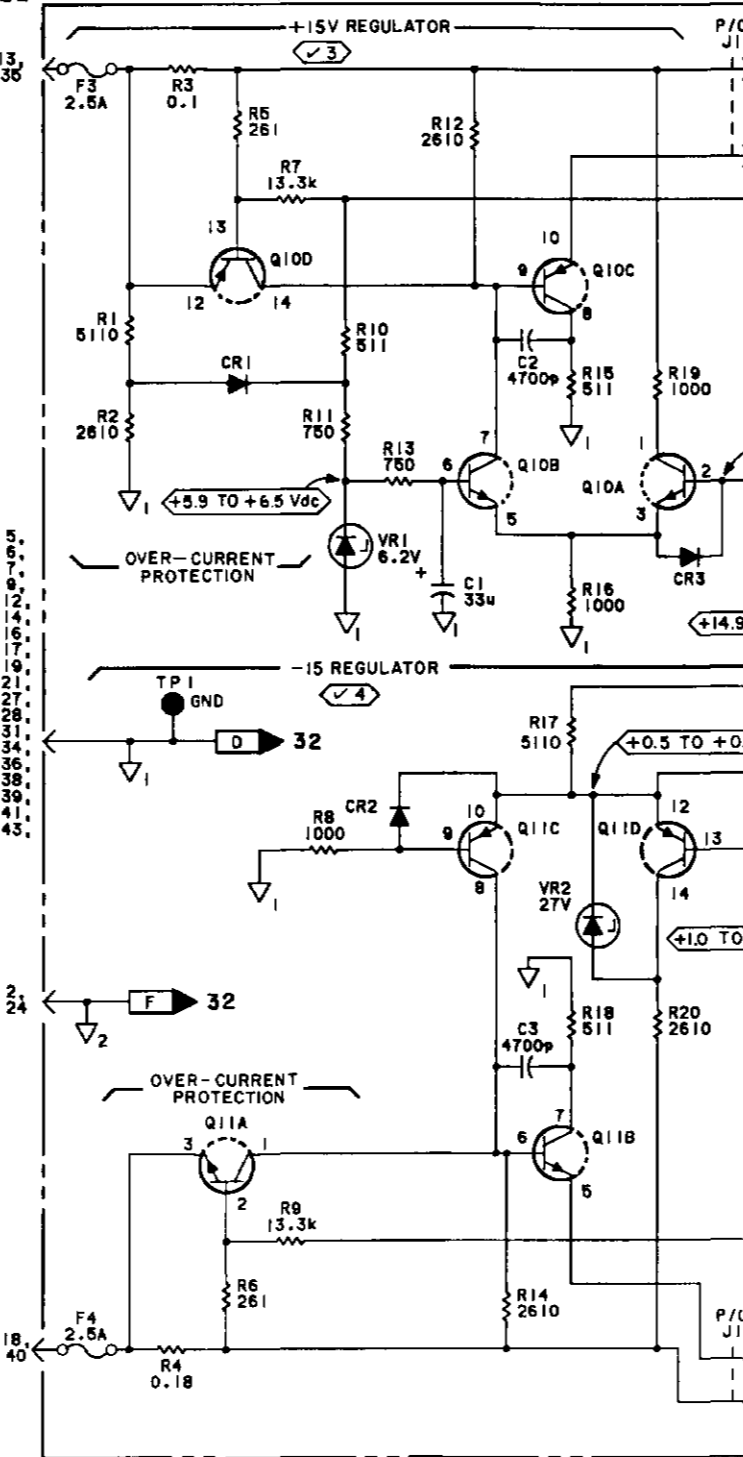

P/O A29 SERIES REGULATOR HEAT SINK ASSEMBLY (08901-60181)

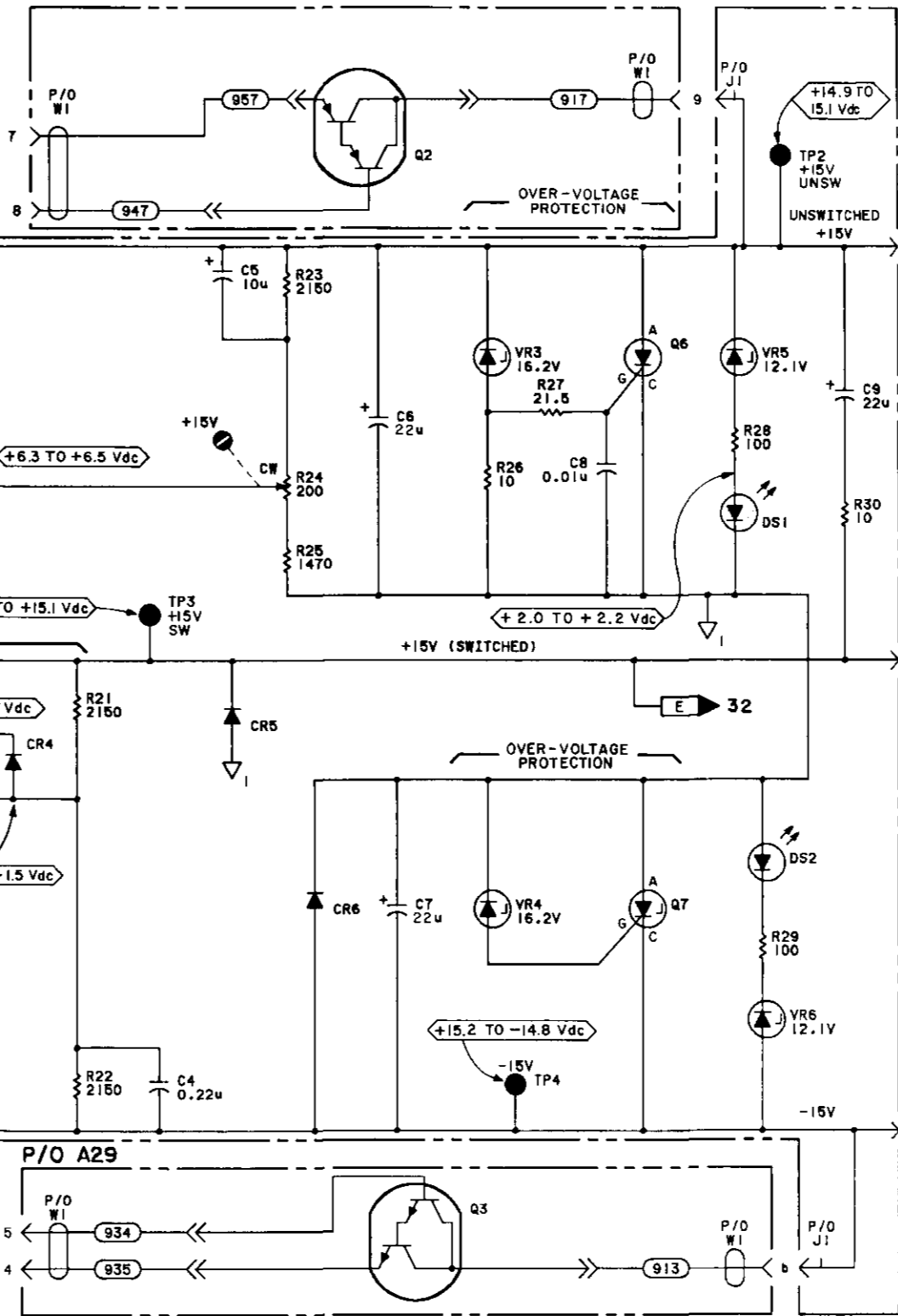

P/O A26

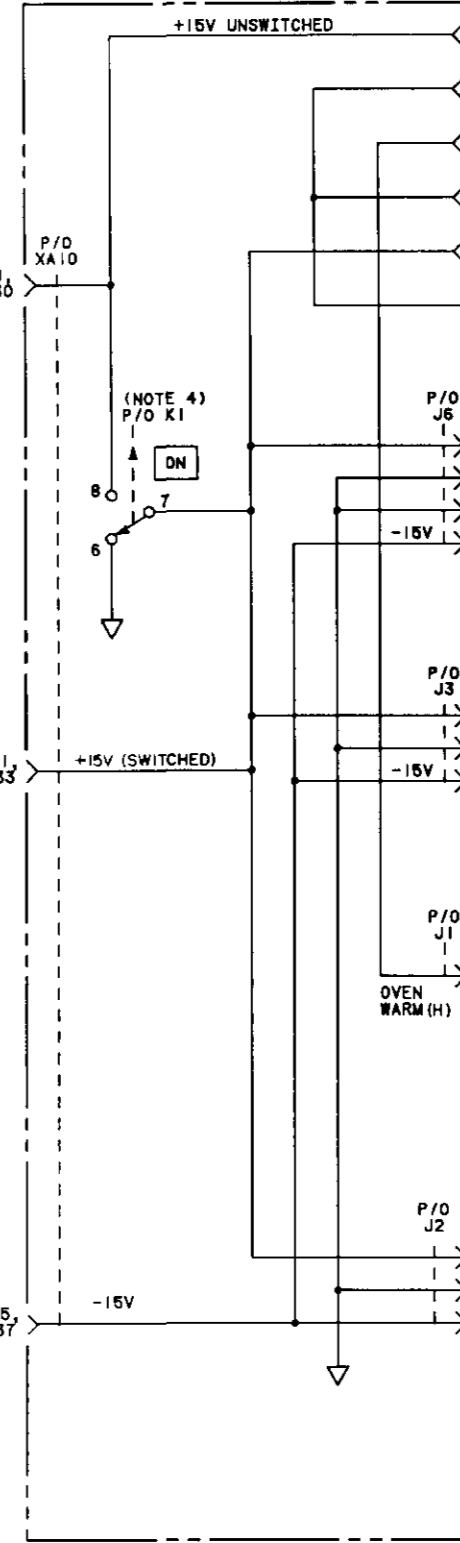

Y1 HIGH STABILITY CRYSTAL OSCILLATOR (OPTION 002 ONLY)

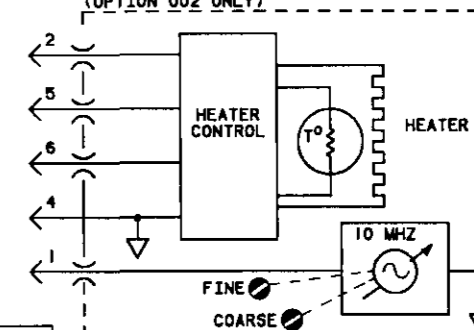

P/O A28 RF MOTHERBOARD ASSEMBLY (08901-60229)

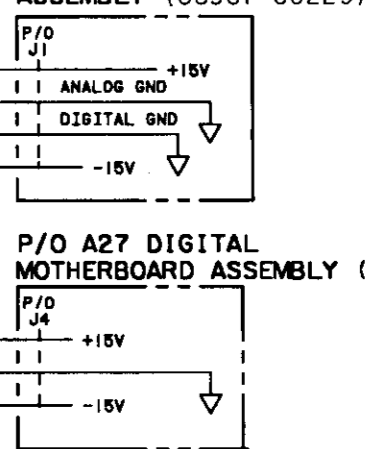

P/O A27 DIGITAL MOTHERBOARD ASSEMBLY (08901-60140)

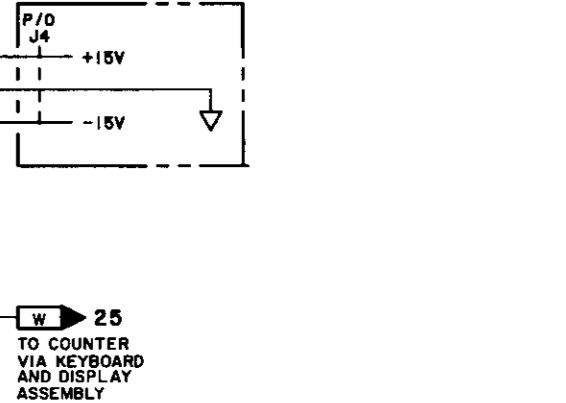

P/O A25 AUDIO MOTHERBOARD ASSEMBLY (08901-60137)



NOTES

- 1. SEE TABLE BA-4 SCHEMATIC DIAGRAM NOTES
2. THE VALUE OF F1 IS 2.5 AMP FOR 110/120V AND 1.5 AMP FOR 220/240V.
3. CHASSIS GROUND IS ACHIEVED BY MECHANICAL CONTACT THROUGH SCREWS HOLDING P.C. BOARD TO FRAME
4. ENERGIZED BY ON/STAND-BY SWITCH SET TO ON

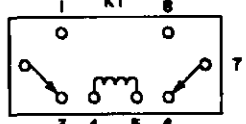

A10 (2314A TO 2515A) & A26 Component Coordinates (2 of 2)

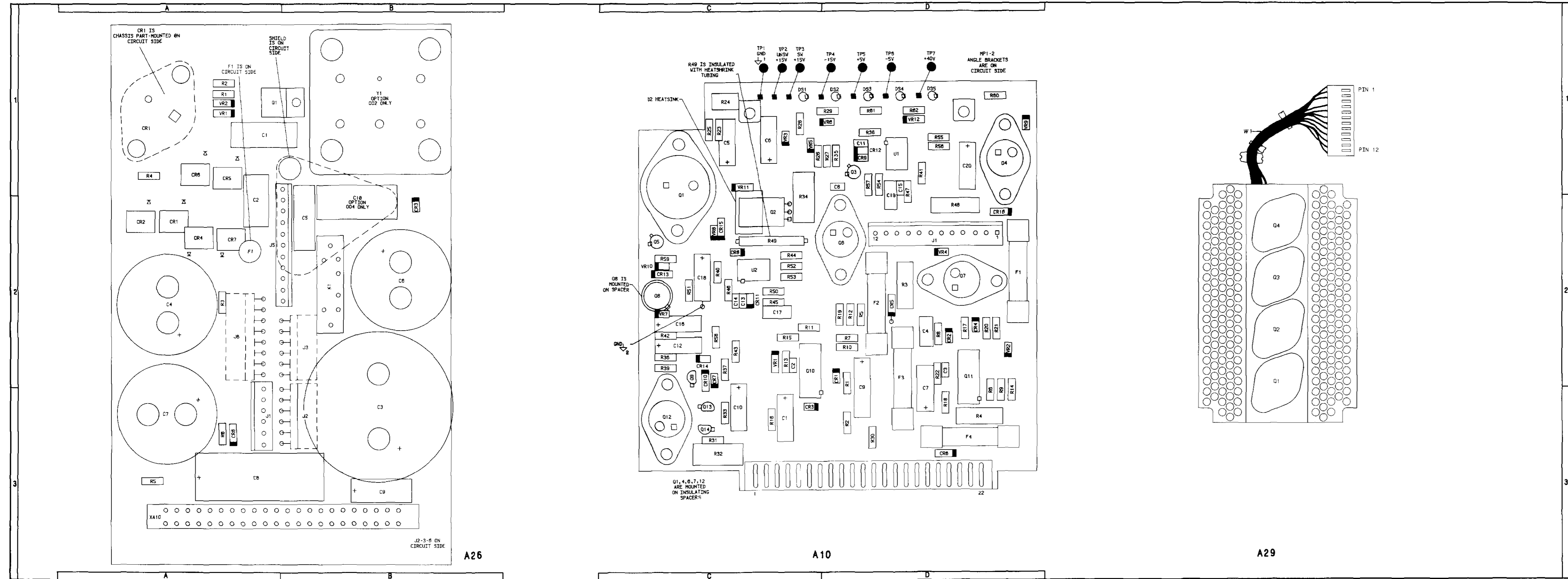

Component Locators

A10 PS REGULATORS A29 SERIES REG HEATSINK **SS31**
 A26 PS MOTHERBOARD A30 LINE POWER

A10		COMP		X,Y		A26		COMP		X,Y		COMP		X,Y	
COMP	X,Y	COMP	X,Y	COMP	X,Y	COMP	X,Y	COMP	X,Y	COMP	X,Y	COMP	X,Y	COMP	X,Y
C10	C,2	R35	D,1	C8	A,3										
C11	D,1	R36	C,2	C9	B,3										
C12	C,2	R37	C,2												
C13	C,2	R38	D,1	CR8	A,3										
C14	C,2	R39	C,2												
C15	D,1	R40	C,2												
C16	D,1	R41	D,1	F1	A,2										
C17	C,2	R42	C,2												
C18	C,2	R43	C,2	J1	A,3										
C19	D,2	R44	C,2	J2	B,3										
C20	D,1	R45	C,2	J3	B,2										
		R46	C,2	J6	A,2										
		R47	D,1												
		R48	D,2												
CR7	C,2	R49	C,2												
CR8	C,2	R50	C,2												
CR9	D,1	R51	C,2												
CR10	C,2	R52	C,2												
CR11	C,2	R53	C,2												
CR12	D,1	R54	D,1												
CR13	C,2	R55	D,1												
CR14	C,2	R56	D,1												
CR15	C,2	R57	D,1												
CR16	D,2	R58	C,2												
		R59	C,2												
DS3	D,1	R60	D,1												
DS4	D,1	R61	D,1												
DS5	D,1	R62	D,1												
F1	D,2	TP1	C,1												
F2	D,2	TP5	D,1												
Q1	C,1	TP6	D,1												
Q2	C,2	TP7	D,1												
Q3	D,1	U1	D,1												
Q4	D,1	U2	C,2												
Q5	C,2	VR7	C,2												
Q8	C,2	VR8	C,2												
Q9	C,2	VR9	D,1												
Q12	C,2	VR10	C,2												
Q13	C,2	VR11	C,1												
Q14	C,2	VR12	D,1												
R31	C,2														
R32	C,2														
R33	C,2														
R34	C,2														

CHANGES

<p>2517A and Above</p>	<p>A10 Component Coordinates:</p> <ul style="list-style-type: none"> • Use the A10 Component Coordinates on page 8G-70.3. <p>A10 Component Locator:</p> <ul style="list-style-type: none"> • Use the A10 Component Locator on page 8G-70.4. <p>On the Schematic:</p> <ul style="list-style-type: none"> • A10 - Change the part number of A10 power supply Regulators Assembly to 08901-60269.
<p>2531A and Above</p>	<p>On the A10 Schematic:</p> <ul style="list-style-type: none"> • R52 - Change the value of R52 to 14.7kΩ.
<p>2618A and Above</p>	<p>On the A10 Schematic:</p> <ul style="list-style-type: none"> • R50, R54 - Change R50 to 4kΩ. Change R54 to 4kΩ.
<p>2806A and Above</p>	<p>On the A26 Schematic:</p> <ul style="list-style-type: none"> • In the upper left portion of SS32, change the P/O A26 POWER SUPPLY MOTHERBOARD ASSEMBLY board part number to 08901-60295.

This page reserved for future changes.

A10 Component Coordinates (2517A and Above)

COMP	X,Y	COMP	X,Y	COMP	X,Y	COMP	X,Y	COMP	X,Y
C1	A,2	R17	B,2						
C2	A,2	R18	B,2						
C3	B,2	R19	A,2						
C4	B,3	R20	B,2						
C5	A,1	R21	B,2						
C6	A,1	R22	B,3						
C7	B,2	R23	A,1						
C8	A,1	R24	A,1						
C9	B,3	R25	A,1						
		R26	A,1						
CR1	A,2	R27	A,1						
CR2	B,2	R28	A,1						
CR3	A,3	R29	A,1						
CR4	B,2	R30	B,3						
CR5	B,3								
CR6	B,3	TP1	A,1						
		TP2	A,1						
DS1	A,1	TP3	A,1						
DS2	A,1	TP4	A,1						
F3	B,2	VR1	A,2						
F4	B,2	VR2	B,2						
		VR3	A,1						
J1	B,2	VR4	B,2						
		VR5	A,1						
Q6	A,2	VR6	A,1						
Q7	B,2								
Q8	A,2								
Q10	A,2								
Q11	B,3								
R1	A,2								
R2	A,2								
R3	B,2								
R4	B,3								
R5	A,2								
R6	B,2								
R7	A,2								
R8	B,2								
R9	B,2								
R10	A,2								
R11	A,2								
R12	A,2								
R13	A,2								
R14	B,2								
R15	A,2								
R16	A,3								

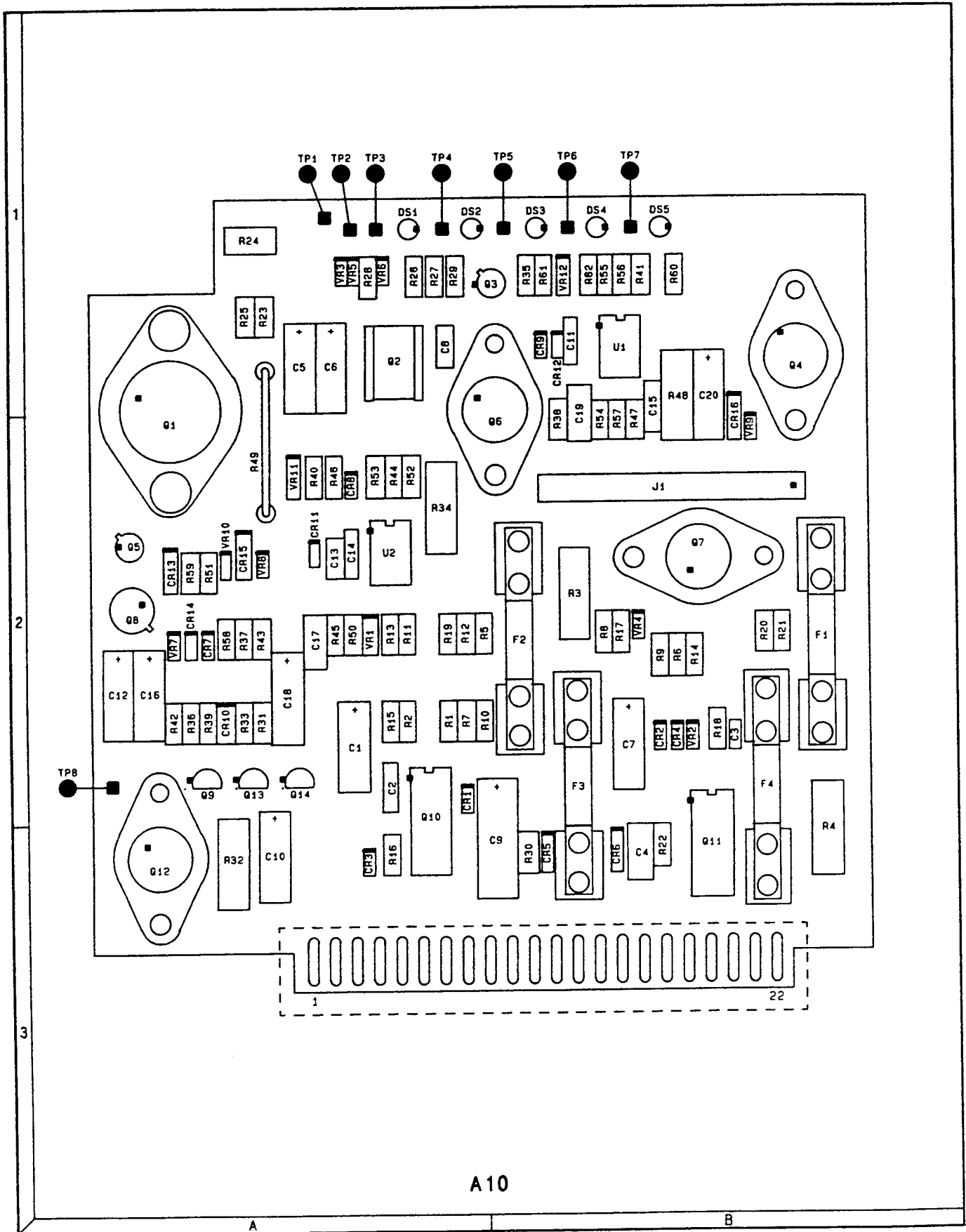

A10

A10 Component Locator
(2517A and Above)

P/O A26 POWER SUPPLY MOTHERBOARD ASSEMBLY (08901-60142)

P/O A10 POWER SUPPLY REGULATORS ASSEMBLY (2 OF 2) (08901-60141)

P/O A28 RF MOTHERBOARD ASSEMBLY (08901-60229)

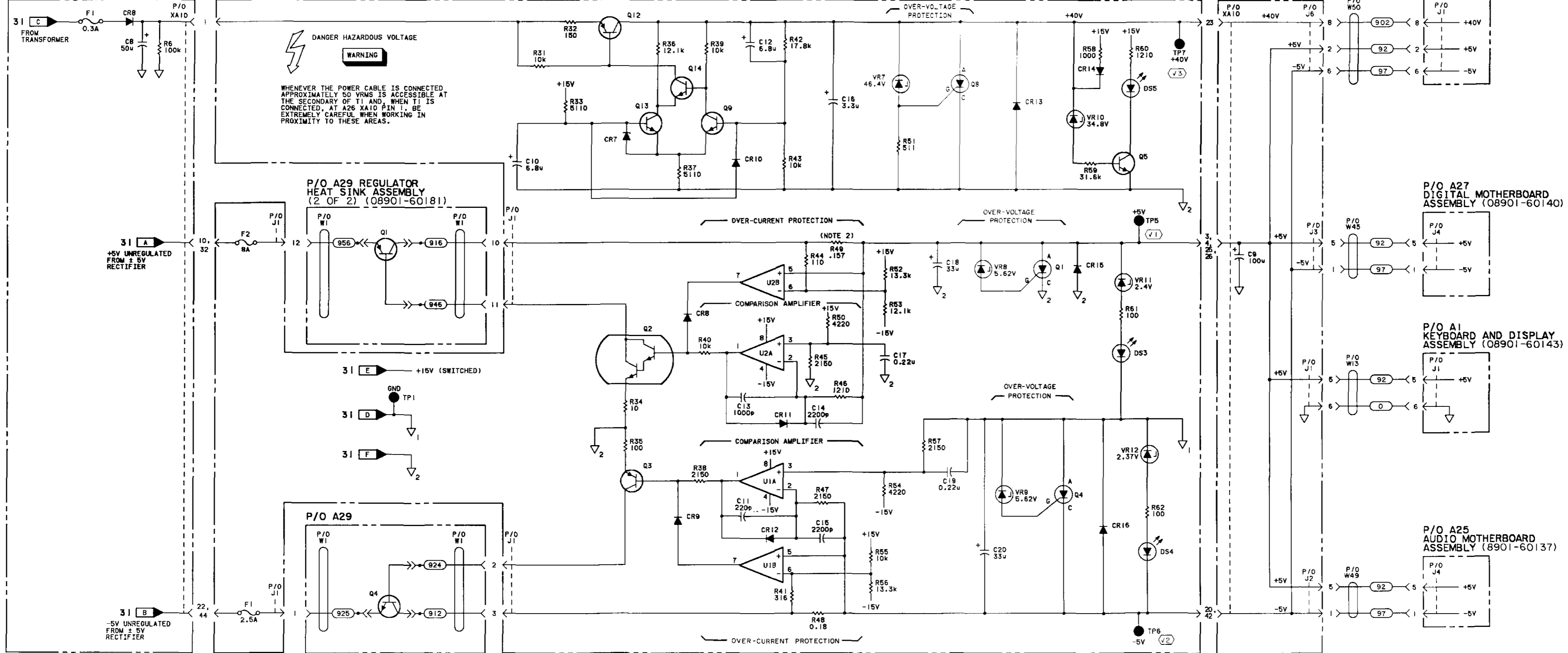

- NOTES:
1. SEE TABLE BA-4 SCHEMATIC DIAGRAM NOTES.
 2. A10 R49 IS A 2.54 CM (1 INCH) STRIP OF NICKEL COPPER.

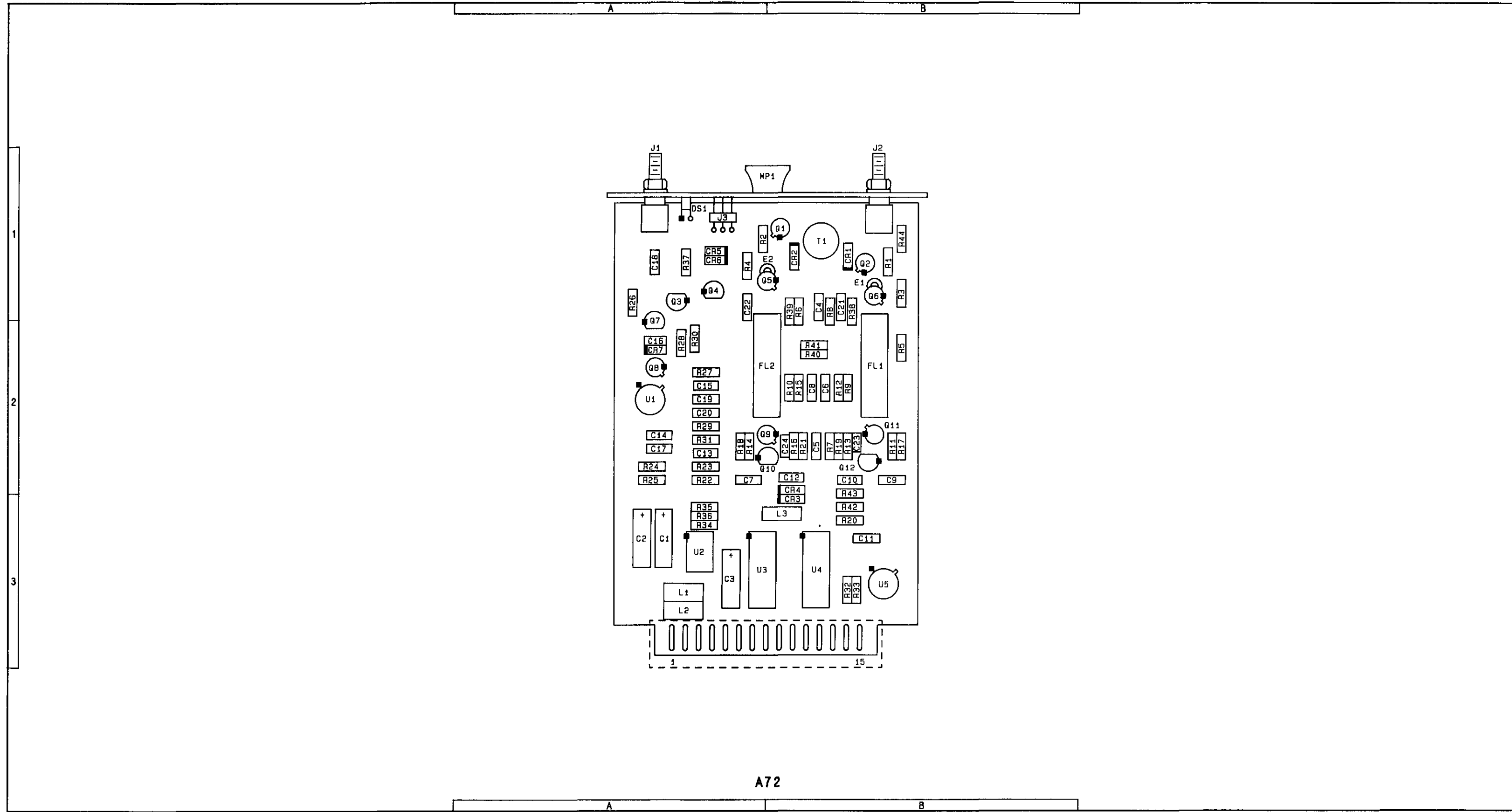

A72

Component Locator

A10 PS REGULATORS SEE REVERSE SIDE
 A26 PS MOTHERBOARD
 A29 SERIES REGULATOR HEATSINK
SS32

A72 Component Coordinates

COMP	X,Y	COMP	X,Y	COMP	X,Y	COMP	X,Y	COMP	X,Y
C1	A,3	L1	A,3	R26	A,1				
C2	A,3	L2	B,3	R27	A,2				
C3	A,3	L3	B,3	R28	A,2				
C4	B,1			R29	A,2				
C5	B,2	MP1	A,1	R30	A,2				
C6	B,2			R31	A,2				
C7	A,2	Q1	B,1	R32	B,3				
C8	B,2	Q2	B,1	R33	B,3				
C9	B,2	Q3	A,1	R34	A,3				
C10	B,3	Q4	A,1	R35	A,3				
C11	B,3	Q5	A,1	R36	A,3				
C12	B,2	Q6	B,1	R37	A,1				
C13	A,2	Q7	A,1	R38	B,1				
C14	A,2	Q8	A,2	R39	B,1				
C15	A,2	Q9	A,2	R40	B,2				
C16	A,2	Q10	A,2	R41	B,2				
C17	A,2	Q11	B,2	R42	B,3				
C18	A,1	Q12	B,2	R43	B,3				
C19	A,2			R44	B,1				
C20	B,1	R1	B,1						
C21	B,1	R2	A,1	T1	B,1				
C22	A,1	R3	B,1						
C23	B,2	R4	A,1	U1	A,2				
C24	B,1	R5	B,2	U2	A,3				
		R6	B,1	U3	A,3				
CR1	B,1	R7	B,2	U4	B,3				
CR2	B,3	R8	B,1	U5	B,3				
CR3	B,3	R9	B,2						
CR4	B,3	R10	B,2						
CR5	A,1	R11	B,2						
CR6	A,1	R12	B,2						
CR7	A,2	R13	B,2						
		R14	A,2						
DS1	A,1	R15	B,2						
		R16	B,2						
E1	B,1	R17	B,2						
E2	A,1	R18	A,2						
		R19	B,2						
FL1	B,2	R20	B,3						
FL2	A,2	R21	B,2						
		R22	A,2						
J1	A,1	R23	A,2						
J2	B,1	R24	A,2						
J3	A,1	R25	A,2						

CHANGES**Errata****On the Schematic:**

- At the top of the schematic, change the reference designator of IF CHANNEL FILTER ASSEMBLY from A72 to A71, and change the part number from 08902-60108 to 08902-60109.

A72 IF CHANNEL FILTER ASSEMBLY (OPTION 030 SERIES) (08902-60108)

NOTES
1. SEE TABLE BA-4 SCHEMATIC DIAGRAM NOTES.

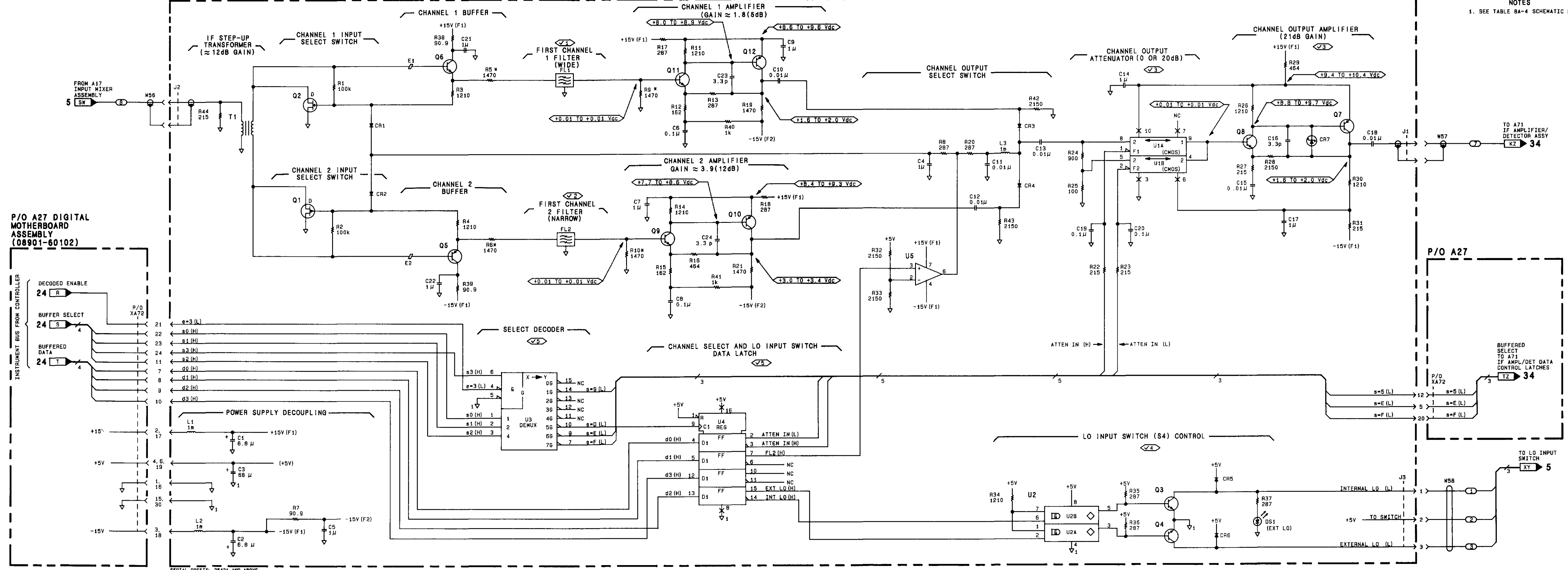

SERIAL PREFIX: 2642A AND ABOVE

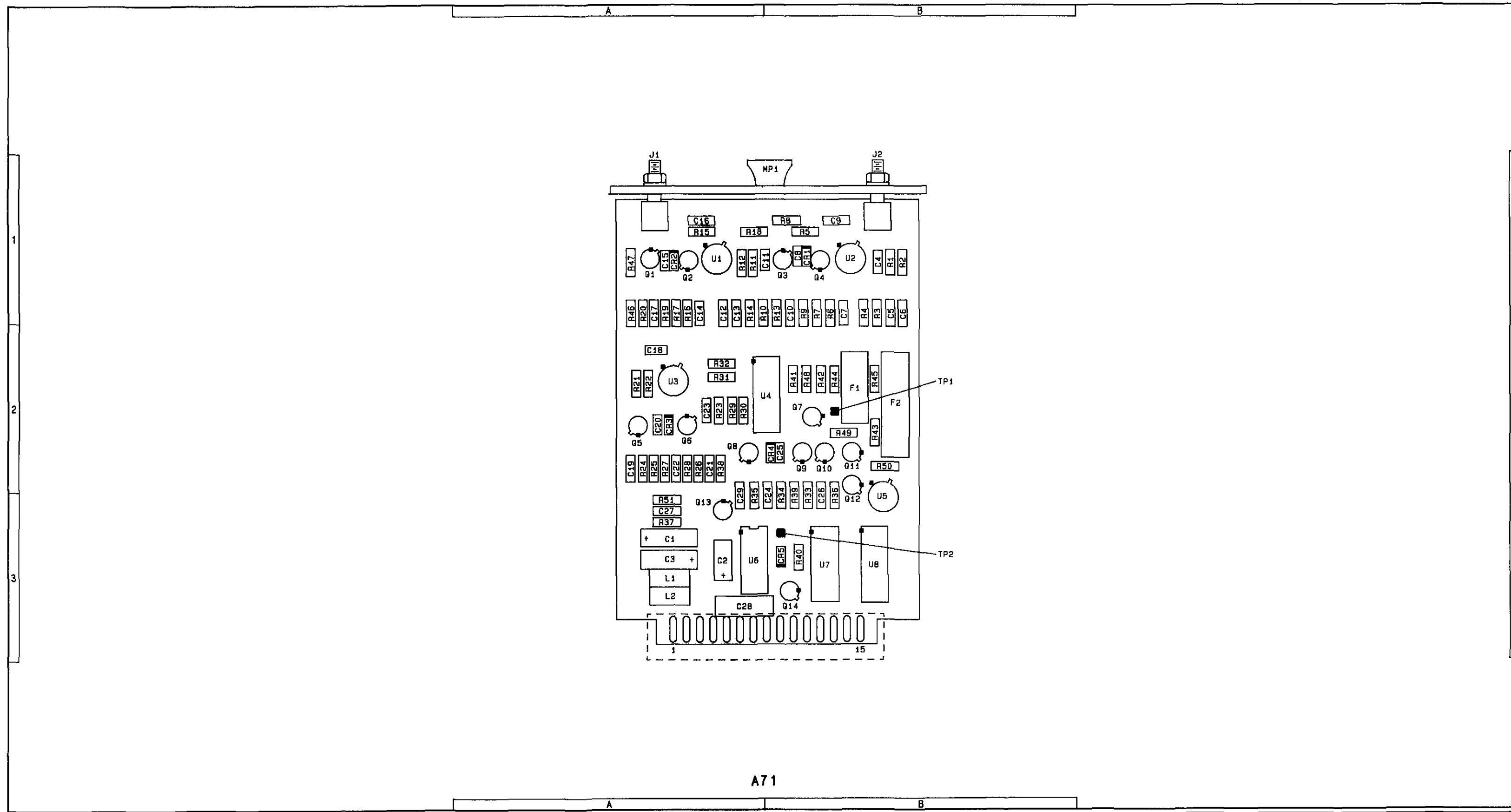

A71 Component Locator

A72 IF CHANNEL FILTER **SS33**
 SEE REVERSE SIDE SERIAL PREFIX: 2642A AND ABOVE

A71 Component Coordinates

COMP	X,Y	COMP	X,Y	COMP	X,Y	COMP	X,Y	COMP	X,Y
C1	A,3	MP1	A,1	R28	A,2				
C2	A,3			R29	A,2				
C3	A,3	Q1	A,1	R30	A,2				
C4	B,1	Q2	A,1	R31	A,2				
C5	B,1	Q3	B,1	R32	A,2				
C6	B,1	Q4	B,1	R33	B,3				
C7	A,1	Q5	A,2	R34	B,3				
C8	B,1	Q6	A,2	R35	A,3				
C9	B,1	Q7	B,2	R36	B,3				
C10	B,1	Q8	A,2	R37	A,3				
C11	A,1	Q9	B,2	R38	A,2				
C12	A,1	Q10	B,2	R39	B,3				
C13	A,1	Q11	B,2	R40	B,3				
C14	A,1	Q12	B,2	R41	B,2				
C15	A,1	Q13	A,3	R42	B,2				
C16	A,1	Q14	B,3	R43	B,2				
C17	A,1			R44	B,2				
C18	A,2	R1	B,1	R45	B,2				
C19	A,2	R2	B,1	R46	A,1				
C20	A,2	R3	B,1	R47	A,1				
C21	A,2	R4	B,1	R48	B,2				
C22	A,2	R5	B,1	R49	B,2				
C23	A,2	R6	B,1	R50	B,2				
C24	B,3	R7	B,1	R51	A,3				
C25	B,2	R8	B,1						
C26	B,3	R9	B,1	TP1	B,2				
C27	A,3	R10	A,1	TP2	B,3				
C28	A,3	R11	A,2						
C29	A,3	R12	A,1	U1	A,1				
		R13	B,1	U2	B,1				
CR1	B,1	R14	A,1	U3	A,2				
CR2	A,1	R15	A,1	U4	A,2				
CR3	A,2	R16	A,1	U5	B,3				
CR4	B,2	R17	A,1	U6	A,3				
CR5	B,3	R18	A,1	U7	B,3				
		R19	A,1	U8	B,3				
F1	B,2	R20	A,1						
F2	B,2	R21	A,2						
		R22	A,2						
J1	A,1	R23	A,2						
J2	B,1	R24	A,2						
		R25	A,2						
L1	A,3	R26	A,2						
L2	A,3	R27	A,2						

CHANGES

2627A and above	On the A27 Schematic: <ul style="list-style-type: none">• A27C9 - On the back of the schematic, in the connector pin-out fourth from the left, on the clock line between pin 27 and pin 44, delete A27C9.
Errata	On the Schematic: <ul style="list-style-type: none">• At the top of the schematic, change the reference designator of IF AMPLIFIER/DETECTOR ASSEMBLY from A71 to A72, and the part number from 08902-60109 to 08902-60108.

A71 IF AMPLIFIER/DETECTOR ASSEMBLY (OPTION 030 SERIES) (08902-60109)

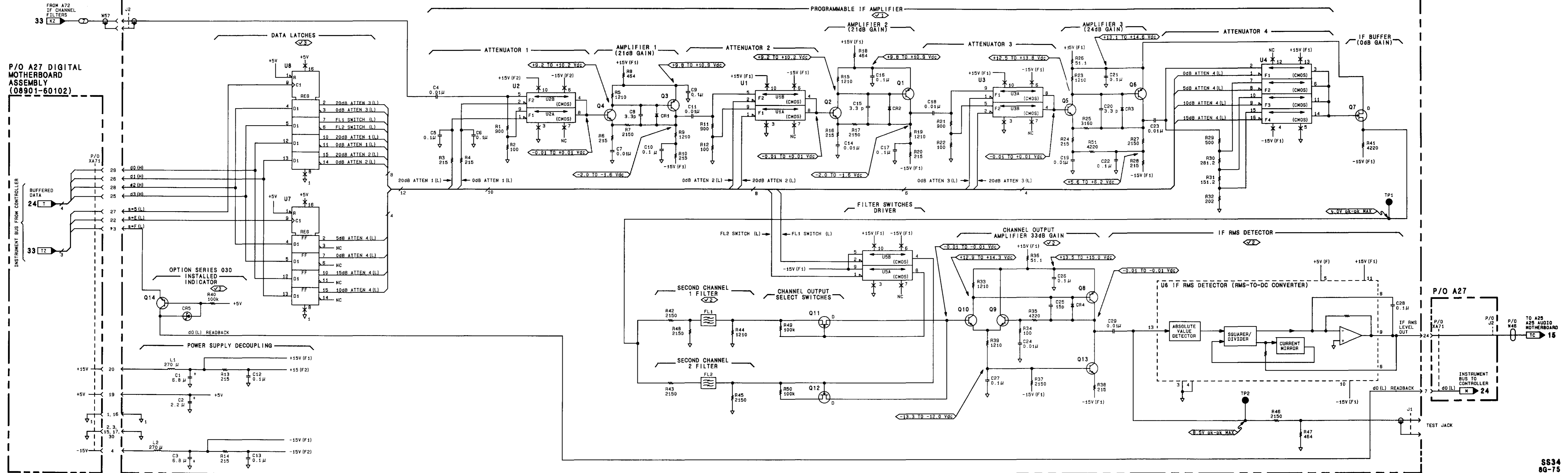

P/O A27 DIGITAL MOTHERBOARD ASSEMBLY (08901-60102)

INSTRUMENT BUS FROM CONTROLLER

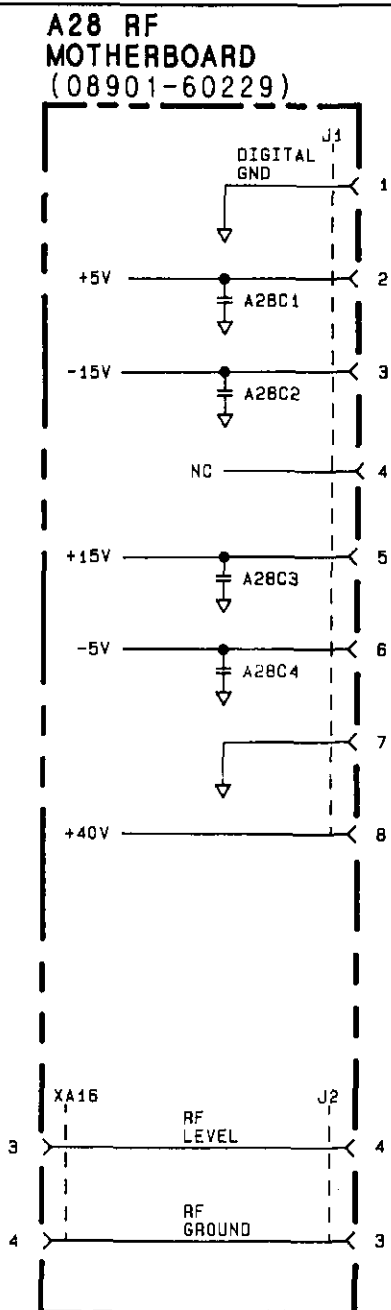
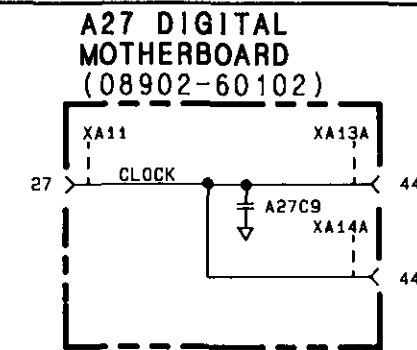
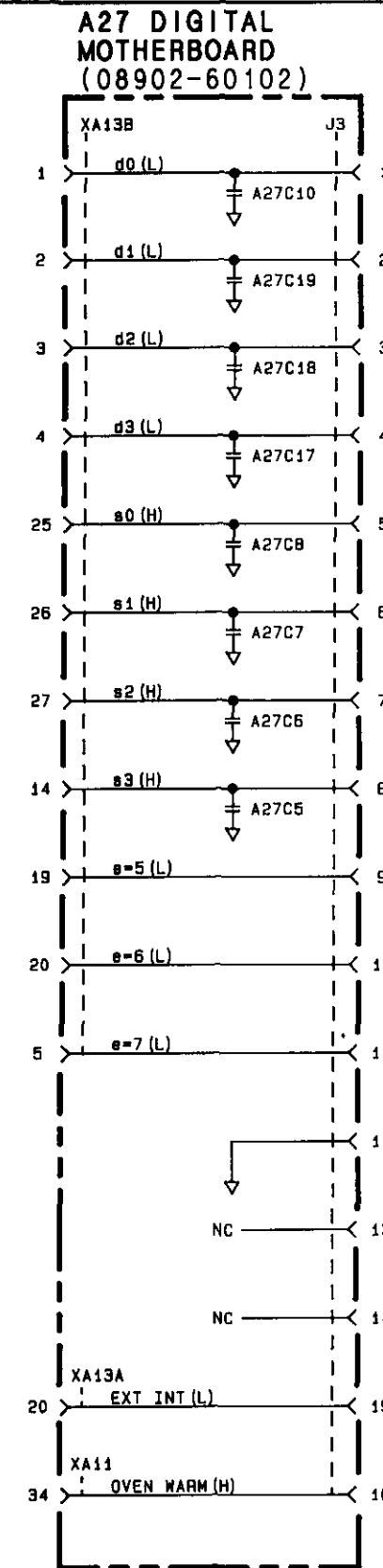
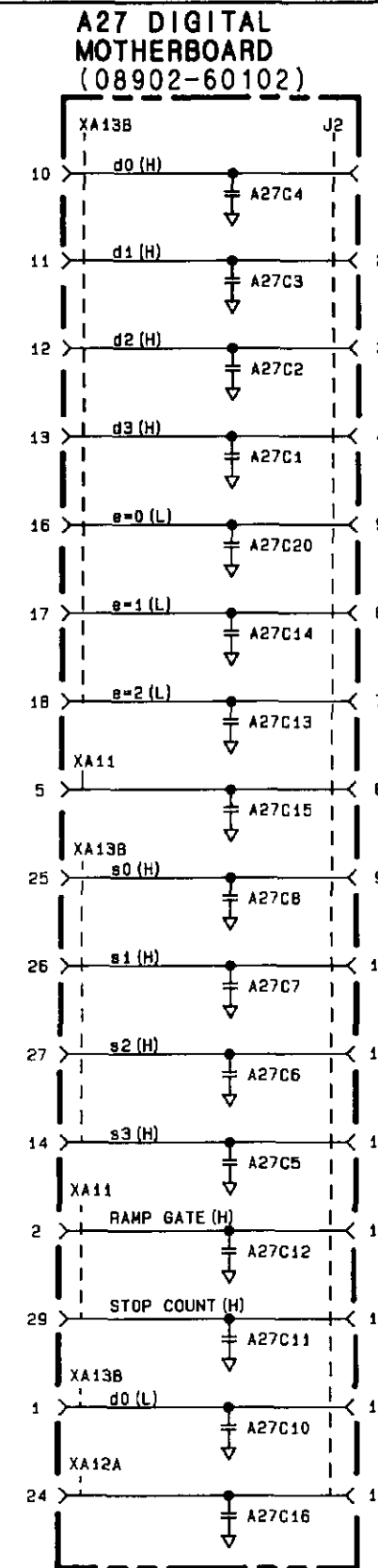
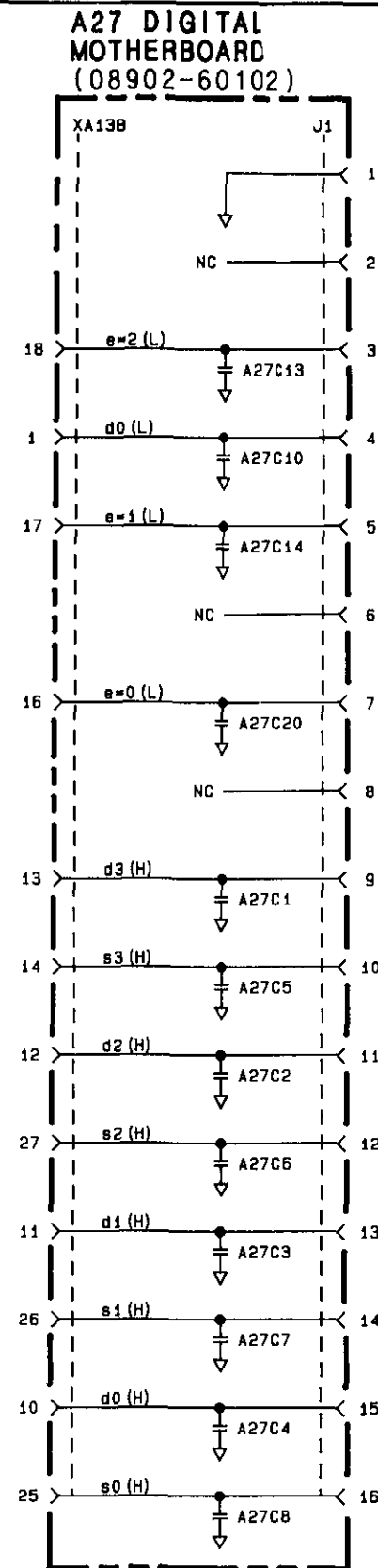

SS34
 A71 IF AMPLIFIER/DETECTOR
 SEE REVERSE SIDE SERIAL PREFIX: 2642A AND ABOVE

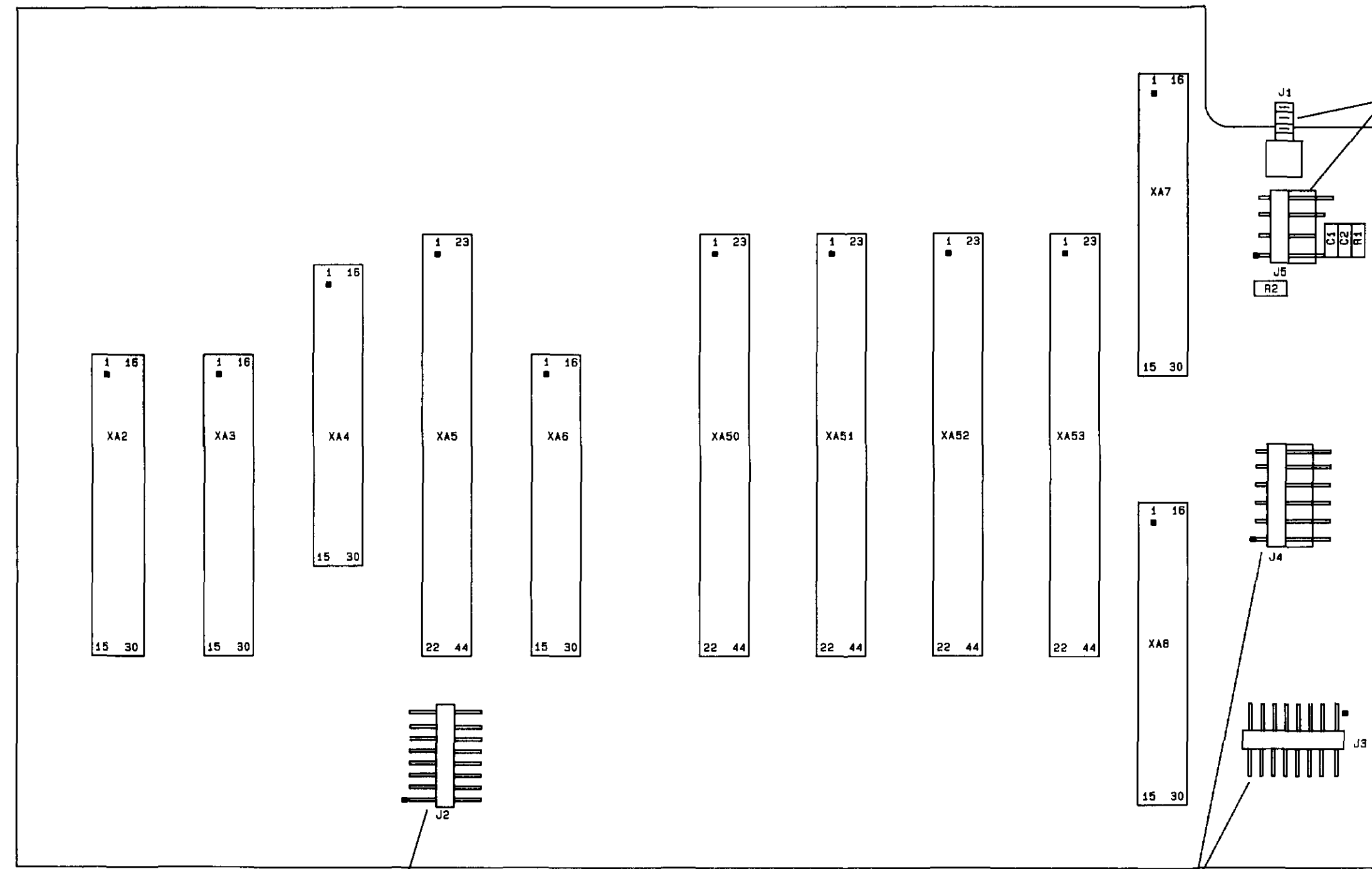

A25 AUDIO MOTHERBOARD
SERIAL PREFIX: 2608 AND BELOW

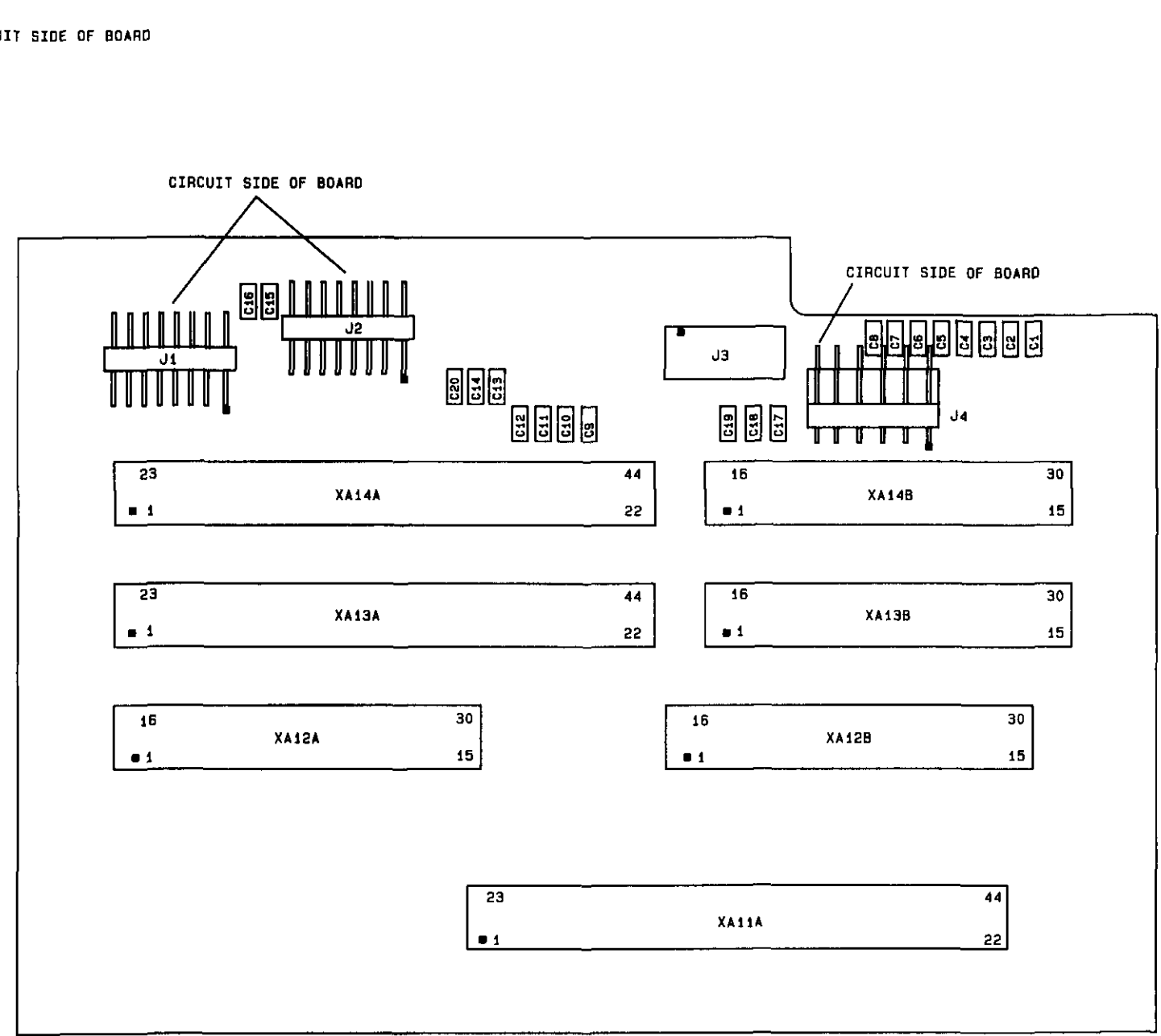

A27 DIGITAL MOTHERBOARD
SERIAL PREFIX: 2636A AND ABOVE

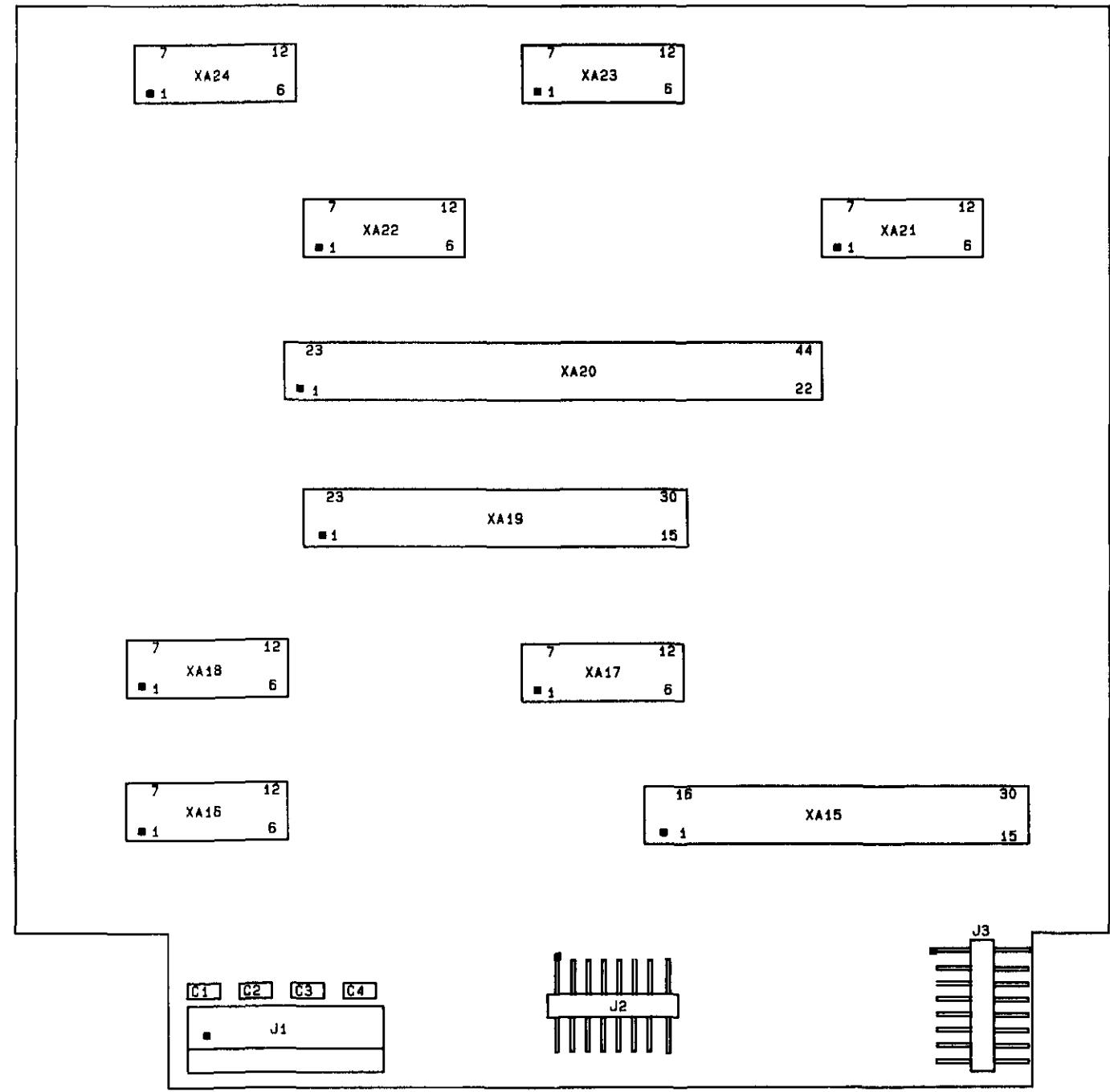

A28 RF MOTHERBOARD
SERIAL PREFIX: 2314A AND ABOVE

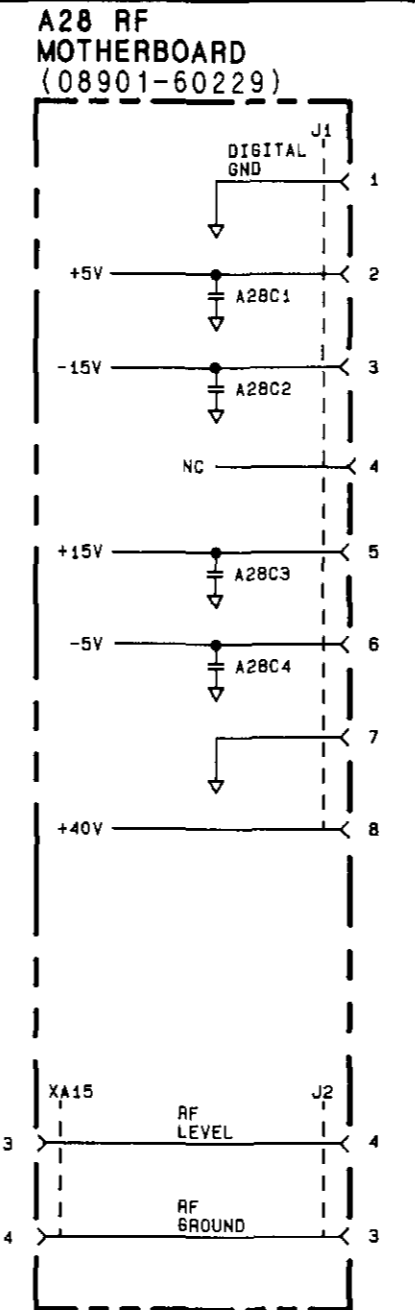
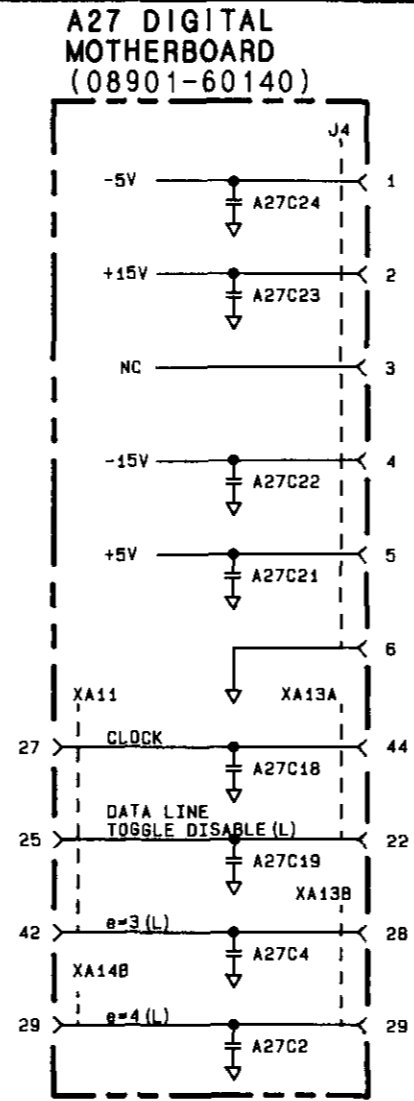
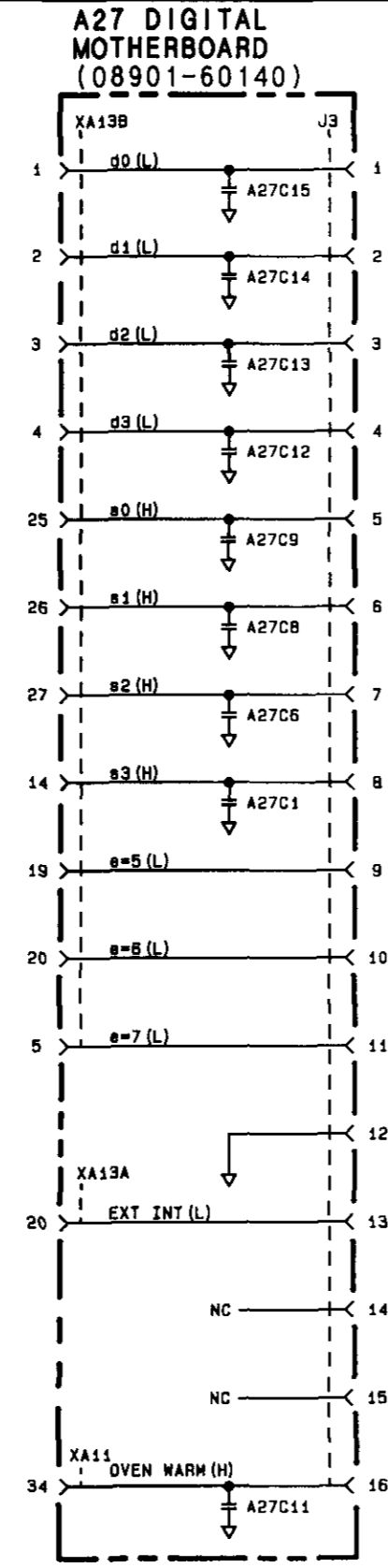
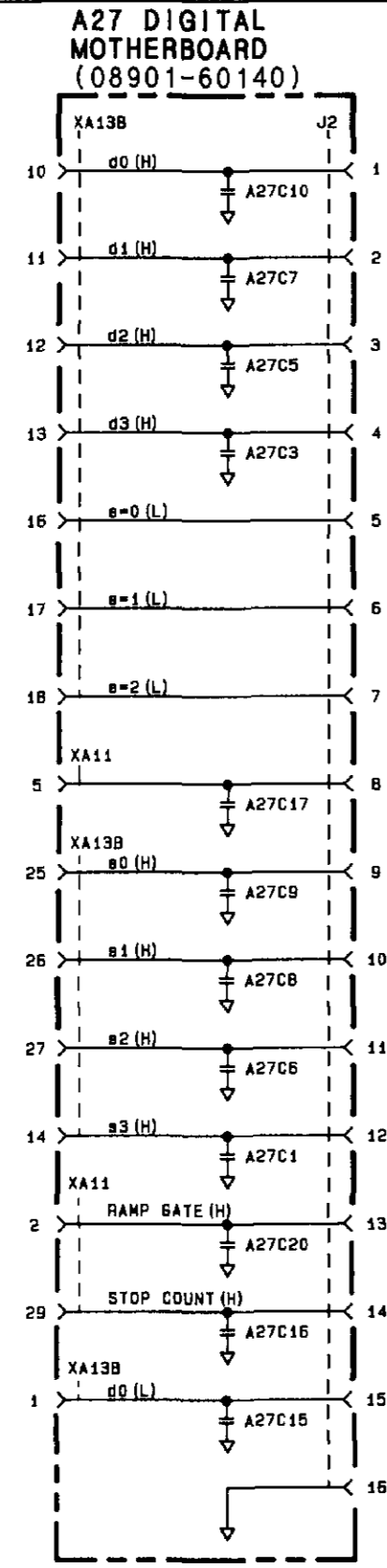
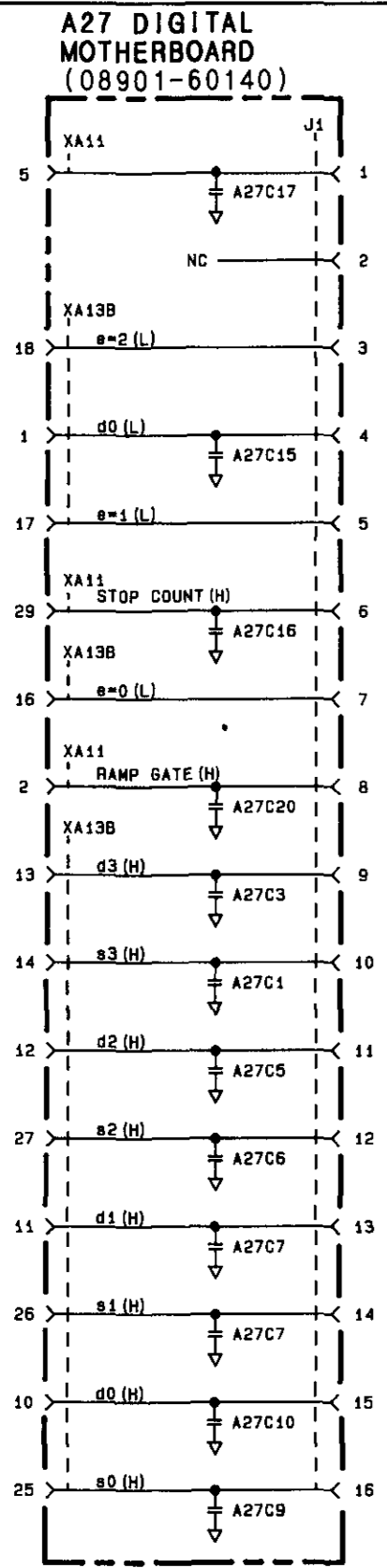

SEE REVERSE SIDE **A25 A27 A28 SS35**

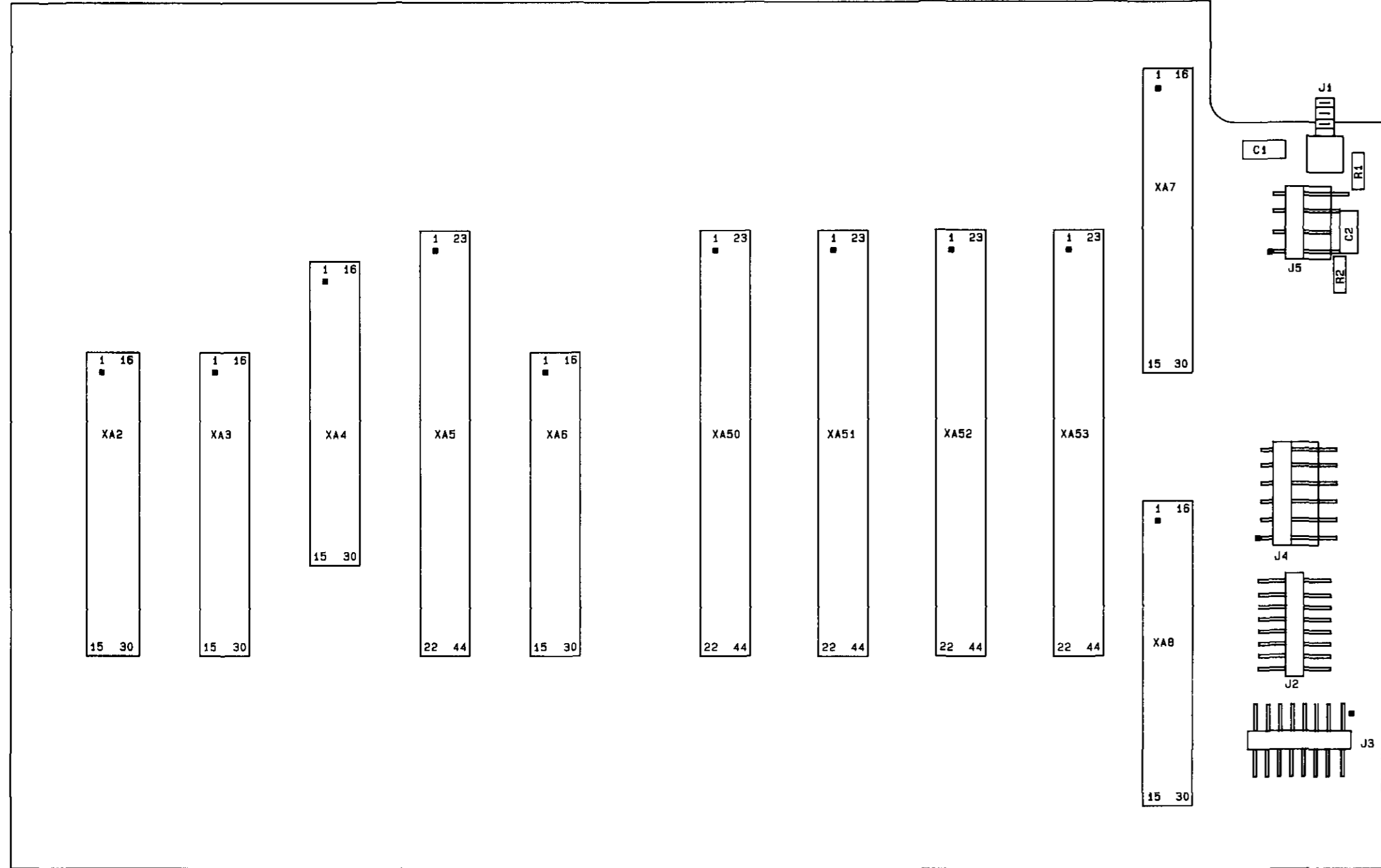

A25 AUDIO MOTHERBOARD
SERIAL PREFIX: 2608 AND BELOW

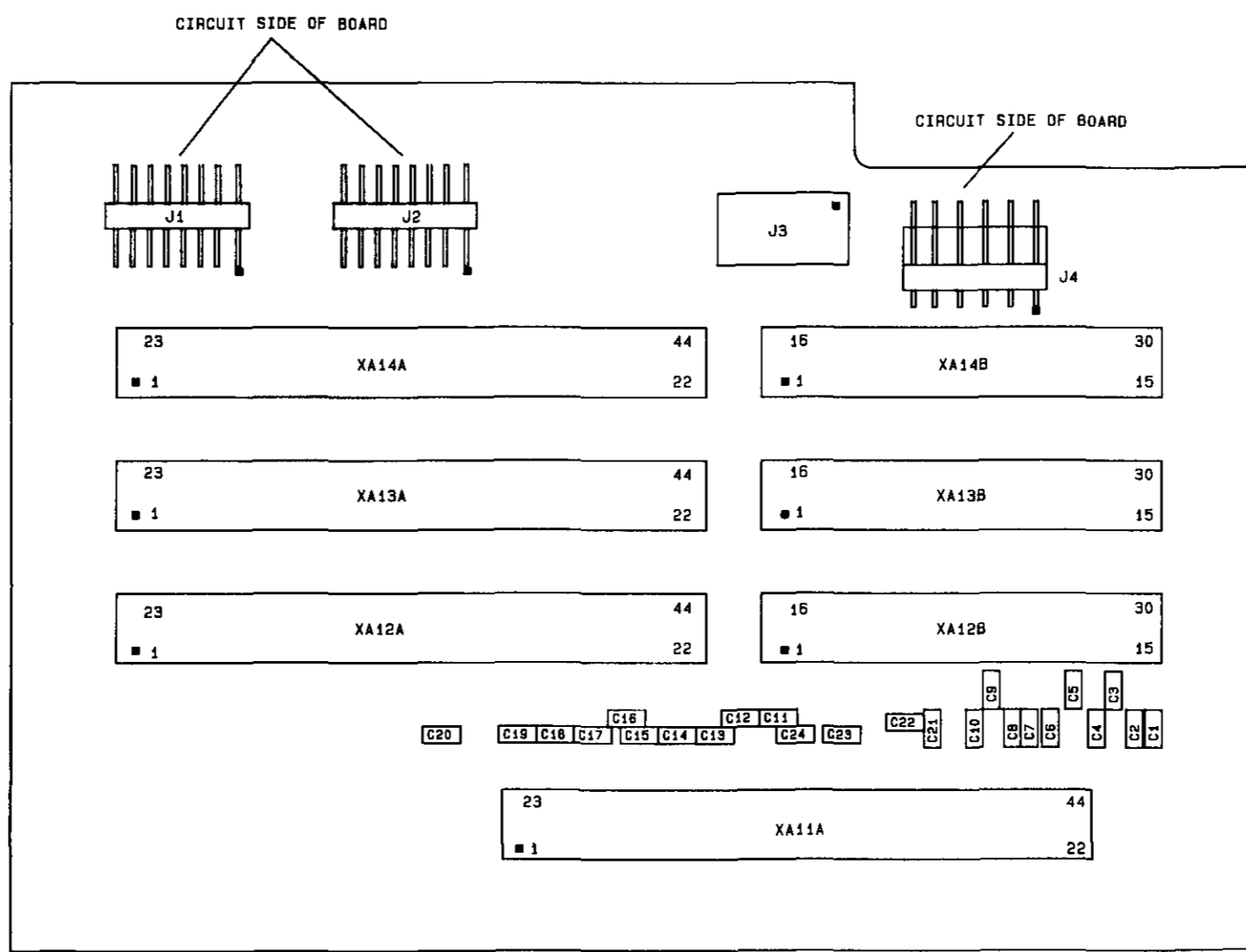

A27 DIGITAL MOTHERBOARD
SERIAL PREFIX: 2635 AND BELOW

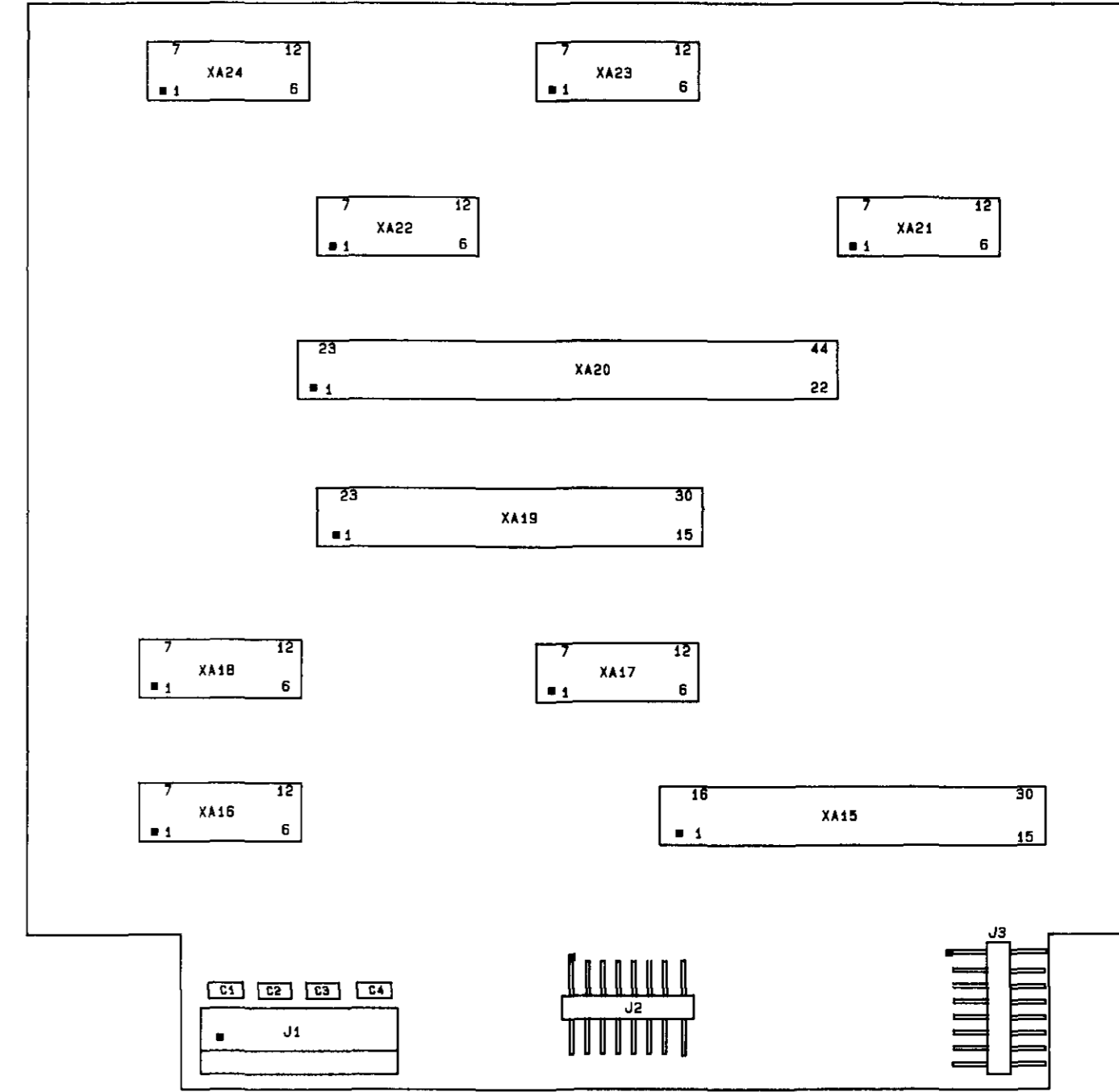

A28 RF MOTHERBOARD
SERIAL PREFIX: 2314A AND ABOVE

Service Sheet A

TOPICS

- Service Special Function Summary
- Error Message Summary

SERVICE SPECIAL FUNCTION SUMMARY

40.0 Controller Reset.

41.0 Controller Clear. (Same as pressing blue key, INSTR PRESET.)

42.0 Display Software Date.

43.N Measurement Progress and Service Error Message Display Control.

N=0 Disables display of Service Error Messages.

N=1 Enables display of Service Error Messages. Cleared by AUTOMATIC OPERATION.

N=2 Enables display of Service Error Messages. Not cleared by AUTOMATIC OPERATION.

N=40 to N=89 Enables measurement to pause on Measurement Progress and Service Error Message determined by N.

N=140 to N=189 Enables measurement to halt on Measurement Progress and Service Error Message determined by N.

44.N Tuned-Flag Control.

N=0 Clears the internal tuned-flag.

N=1 Sets the internal tuned-flag.

45.N AM and FM Calibrator and RF Power Reference Control.

N	AM Calibrator		FM Calibrator Frequency	RF Power Reference
	Channel A	Channel B		
0	Off	Off	Low	Off
1	On	Off	Low	Off
2	Off	On	Low	Off
3	On	On	Low	Off
4	Switching 33% AM		Low	Off
5	Switching 100% AM		Low	Off
6	On	Off	High	Off
7	Off	On	High	Off
8	On	On	High	Off
9	Switching 33% AM		High	Off
10	Switching 100% AM		High	Off
11	On	Off	Switching	Off
12	Off	On	Switching	Off
13	On	On	Switching	Off
14	Switching 33% AM		Switching	Off
15	Switching 100% AM		Switching	Off
16	Off	Off	Low	On
17	On	Off	Low	On
18	Off	On	Low	On
19	On	On	Low	On
20	Switching 33% AM		Low	On
21	Switching 100% AM		Low	On
22	On	Off	High	On
23	Off	On	High	On
24	On	On	High	On
25	Switching 33% AM		High	On
26	Switching 100% AM		High	On
27	On	Off	Switching	On
28	Off	On	Switching	On
29	On	On	Switching	On
30	Switching 33% AM		Switching	On
31	Switching 100% AM		Switching	On

46.N Count Internal Signals.

- N=1 Intermediate Frequency
- N=2 Voltage-to-Time Converter
- N=3 FM Calibrator
- N=4 High Frequency VCO Divided by 8
- N=8 Selected Time Base Reference
- N=9 External Time Base Reference
- N=A Internal Time Base Reference
- N=B Audio Counter Input or IF Synchronous Detector VCO (depends on which mode was last used)

49.N Display Internal Voltages.

- N=0 Ground
- N=1 RF Ground
- N=2 RF Level ÷3
- N=3 RF Level
- N=4 ×10 AM Calibrator
- N=5 ×1 AM Calibrator
- N=6 Audio Range Detector
- N=7 RMS-to-DC Converter
- N=8 Ground
- N=9 Audio Average Detector
- N=A Audio Peak Detector
- N=B IF Average Detector
- N=D IF Level
- N=E ALC Current
- N=F RF Average Power or Sensor Identifier. To read average power, precede with Special Function 0.212. To read sensor identifier, precede with Special Function 0.211.

50.N Display Internal Voltages.

- N=0 Ground
- N=1 -15V Supply
- N=2 -5V Supply
- N=3 +5V Supply
- N=4 +15V Supply
- N=5 +40V Supply
- N=6 IF RMS Detector (Option 030 Series)

52.N Read-Only Memory Verification. (N=ROM number: 1, 2, or 3)

54.N Local Oscillator Test.

N=0 Performs all tests below—displays number of first test failed.

N	Test Number	Display Digits	Test
1	01	1 and 2	(Undefined)
1	02	3 and 4	Time Base
1	03	5 and 6	Counter
1	04	7 and 8	HF VCO and Divider Output
2	05	1 and 2	HF VCO Tuned to Top of Range
2	06	3 and 4	HF VCO Tuned to Bottom of Range
2	07	5 and 6	HF VCO Tuned to Mid-Range
2	08	7 and 8	(Undefined)
3	09	1 and 2	Gain of Most Significant DAC
3	10	3 and 4	Gain of Least Significant DAC
3	11	5 and 6	(Undefined)
3	12	7 and 8	(Undefined)
4	13	1 and 2	Phase Lock Loop Acquisition
4	14	3 and 4	Phase Lock Loop Stability
4	15	5 and 6	(Undefined)
4	16	7 and 8	(Undefined)
5	17	1 and 2	Tune LF VCXO with DAC
5	18	3 and 4	Gain of LF VCXO Drive
5	19	5 and 6	(Undefined)
5	20	7 and 8	(Undefined)

55.0 Sweep Doubler Band.

56.0 Sweep Bands 4 through 8.

57.0 Sweep Bands DBLR through 3.

60.0 Key Scan. (Jumper A13TP1 to A13TP3.)

61.N Display HP-IB Status.

N=0 <Addressed to Talk>.<Addressed to Listen> (True=1)

N=1 <DAV>.<RFD><DAC> (True=1)

N=2 <ATN>.<REN> (True=1)

N=3 <SPM>.<SRQ> (True=1)

N=4 PIO Port A (True=1)

Display Digit	1	2	3	4	5	6	7	8
Mnemonic	IO8	IO7	IO6	IO5	IO4	IO3	IO2	IO1

N=5 PIO Port B (True=1)

Display Digit	1	2	3	4	5	6	7	8
Mnemonic	ATN	ARD	AAD	SRQ	RNL	ATT	ATL	SDV

ERROR MESSAGE SUMMARY

The error messages are grouped by error code as follows:

1. Error 01 through Error 19 and Error 90 through Error 99 are Operating Errors. Refer to the *Operation and Calibration Manual* for additional information.
2. Error 20 through Error 29 are Entry Errors. Refer to the *Operation and Calibration Manual* for additional information.
3. Error 40 through Error 89 are Service Errors. Refer to paragraph 8-8 for additional information.

NOTE

Not all of the available error message numbers are used.

Operating Errors (Error 01 through Error 19 and Error 90 through Error 99).

- Error 01—IF frequency error.
- Error 02—Input level too high.
- Error 03—Input level too low.
- Error 04—Audio circuits overdriven.
- Error 05—FM squelched.
- Error 06—RF input overload.
- Error 07—Voltmeter and display overload.
- Error 08—Calibrator error.
- Error 09—Option not installed.
- Error 10—Input frequency out of range.
- Error 11—Calculated value out of range.
- Error 12—Time base oven cold (Option 002).
- Error 13—Power sensor not connected.
- Error 14—Power sensor cannot zero.
- Error 15—Calibration factor error.
- Error 16—Audio circuits underdriven.
- Error 17—Selective power measurement error (Option Series 030).
- Error 18—RF power will not calibrate.
- Error 96—No input signal sensed by instrument (HP-IB only).

Entry Errors (Error 20 through Error 29)

- Error 20—Entered value out of range.
- Error 21—Invalid key sequence.
- Error 22—Invalid Special Function prefix.
- Error 23—Invalid Special Function suffix.
- Error 24—Invalid HP-IB code.
- Error 25—Special Functions selected not compatible with selected measurement.
- Error 26—End of RF power calibration factor table reached.

Service Errors (Error 40 through Error 89)

- Error 70—Phase lock loop stepdown.
- Error 71—Phase lock loop step up.
- Error 72—Audio overload.
- Error 74—FM Calibrator over deviation.
- Error 75—FM Calibrator under deviation.
- Error 76—AM Calibrator modulators unequal.
- Error 77—AM Calibrator channel B out of range.
- Error 78—Key not found.
- Error 79—Audio autorange rangeback.
- Error 80—Audio settling timeout.
- Error 81—LO tuning adjusted to center signal in IF passband.
- Error 82—Unable to make audio count.
- Error 89—Software error.

Service Sheet B

TOPIC

- Direct Control Special Function Summary

General Instrument Readback Control

Function Readback	Direct Control Special Function	Service Sheet	Meaning of Readback
Overpower Protect	0.050	21	d0=1 if relay tripped
IF Present	0.0E0	9	d0=1 if IF present
FM Squelch	0.170	13	d0=1 if squelched
Audio Overvoltage	0.150	13	d0=1 if overvoltage
Parity	0.1Fd then 0.100	15	d0=0 if d0+d1+d2+d3 is even; d0=1 if odd
Audio Counter	0.296	16	d0=carry output of stage 4
Time Base Oven	0.300	23	d0=0 if cold
Time Base	0.360	23	d3=state of time base
Counter Carry	0.360	23	d2=1 if carry
Counter Stage 4	0.350	23	d=output
Counter Stage 3	0.340	23	d=output
Counter Stage 2	0.330	23	d=output
Counter Stage 1	0.320	23	d=output
Option Series 030	0.3F0	34	d0=1 if option present
HP-IB Address	0.450	28	d=complement of most significant bits
HP-IB Address	0.460	28	d0=complement of least significant bits; d1=0 if talk only; d2=0 if listen only; d3=1 if Serial Poll Flip-Flop set
Keyboard	0.7s0	25	See following table.

Keyboard Readback (0.7d0 SPCL). After entering the Special Function, ground A13TP3. See Service Sheet 25.

Direct Control Special Function	Display vs. Key Pressed			
	000111.0000	001011.0000	001101.0000	001110.0000
0.700	>20 kHz	15 kHz	3 kHz	300 Hz
0.710	750 μs	75 μs	50 μs	25 μs
0.720	LOG/LIN	RATIO	AVG	PEAK HOLD
0.730	FREQ	RF POWER	ΦM	FM
0.740	MHz	9	8	7
0.750	kHz ↑	6	5	4
0.760	kHz ↓	3	2	1
0.770	SPCL	CLEAR	• (Dec. Point)	0
0.780	50 Hz	LCL	(None)	(None)
0.790	PRE DISPLAY	CALIB	ZERO	(None)
0.7A0	PEAK-	PEAK+	(None)	(None)
0.7B0	AM	S (Yellow)	(None)	(None)
0.7C0	AUTO OPER	AUDIO INPUT	(None)	(None)
0.7D0	TRACK MODE	(None)	(None)	(None)
0.7E0	RANGE HOLD	(None)	(None)	(None)
0.7F0	(Blue)	(None)	(None)	(None)

Hexadecimal Information for Direct Control Special Function Entry

Hexadecimal Character	Decimal Equivalent	Binary Equivalent	Keystroke Entry	HP-IB Code Entry	Display On Entry
0	0	0000	0	0	0
1	1	0001	1	1	1
2	2	0010	2	2	2
3	3	0011	3	3	3
4	4	0100	4	4	4
5	5	0101	5	5	5
6	6	0110	6	6	6
7	7	0111	7	7	7
8	8	1000	8	8	8
9	9	1001	9	9	9
A	10	1010	S (Shift) 0	X0	A
B	11	1011	S (Shift) 1	X1	b
C	12	1100	S (Shift) 2	X2	C
D	13	1101	S (Shift) 3	X3	d
E	14	1110	S (Shift) 4	X4	E
F	15	1111	S (Shift) 5	X5	F

1 **Power Meter Attenuation Control (0.20d SPCL).** See Service Sheets 1 and 2.

Attenuator 1	Attenuator 2	Direct Control Special Function
0 dB	0 dB	0.203
0 dB	20 dB	0.205
0 dB	40 dB	0.209
40 dB	20 dB	0.204
40 dB	0 dB	0.202

2 **Power Meter Noise Filter Bandwidth and Frequency Offset Mode Control (0.23d SPCL).** See Service Sheet 2.

Noise Filter Bandwidth	Frequency Offset Mode	Voltage at FREQ OFFSET TTL OUT	Direct Control Special Function
Wide	Not offset	0 Vdc	0.231
Wide	0-18 GHz	+5 Vdc	0.233
Wide	18-40 GHz	+3 Vdc	0.23F
Narrow	Not offset	0 Vdc	0.230
Narrow	0-18 GHz	+5 Vdc	0.232
Narrow	18-40 GHz	+3 Vdc	0.23E

3 **Sensor Module and Power Calibrator Control (0.21d and 0.24 SPCL).** To actually switch the RF path within a Sensor Module, the module must be triggered. After keying in the Direct Control Special Function, key in 0.24 SPCL. See Service Sheets 2 and 3.

Readback Mode	Power Calibrator	Sensor Module Mode	Direct Control Special Function
Power meter	Off	Power sensor	0.21A
Power meter	On	Power sensor	0.21E
Power meter	On	Thru path	0.216
Sensor type	On	Thru path	0.215

4 **Power Sensor Zeroing DAC Setting.** Key in 0.22d SPCL. The value of the data (d) determines the output of the DAC. See Service Sheet 2.

Modified Block Diagram

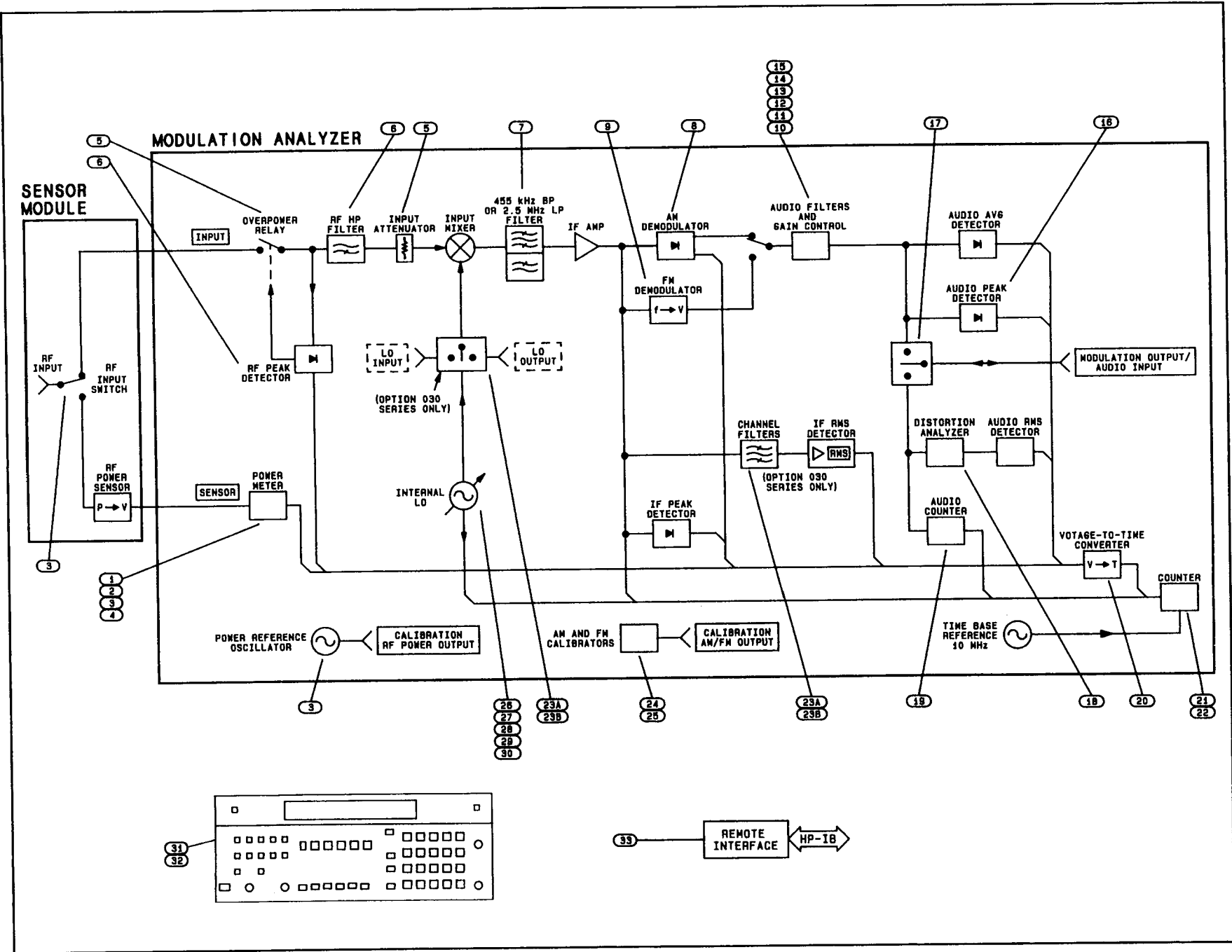

5 Input Attenuator Control and Overpower Reset (0.04d SPCL). See Service Sheets 4 and 21.

Attenuator	Direct Control Special Function	
	Without Overpower Reset	With Overpower Reset
Thru Path	0.04F	0.047
10 dB	0.04D	0.045
20 dB No. 2	0.04E	0.046
20 dB No. 1	0.04B	0.043

6 RF Peak Detector Control and 5.25 MHz High-Pass Filter Select (0.02d SPCL). See Service Sheets 4 and 21.

RF Peak Detector	Direct Control Special Function	
	High-Pass Filter In	High-Pass Filter Out
On	0.02C	0.024
Off	0.028	0.020

7 IF Select (0.03d SPCL). See Service Sheets 4, 5, and 21.

IF (Filter)	Direct Control Special Function
1.5 MHz (4 MHz LP)	0.030
455 kHz (455 kHz BP)	0.031
1.5 MHz (4 MHz LP)	0.032
455 kHz (455 kHz BP)	0.033

8 AM ALC Control (0.0Dd SPCL). See Service Sheets 8 and 9. Also see *Readback Control* table.

ALC Mode	Direct Control Special Function
Off	0.0D0
Fast	0.0D3
Slow	0.0D1

9 FM Squelch (0.15d SPCL). See Service Sheet 11. Also see *Readback Control* table.

Squelch	Direct Control Special Function
On	0.150
Off	0.152

10 Audio Input Select and Audio Overvoltage Detector Reset (0.11d SPCL). See Service Sheet 13. Also see *Readback Control* table.

Function	Direct Control Special Function
High gain FM; detector reset	0.118
Low gain FM; detector reset	0.112
AM; detector reset	0.111
No input; no detector reset	0.110

11 Audio Gain Control (0.12d SPCL). See Service Sheets 12 and 13.

Audio Gain	Direct Control Special Function
High	0.121
Low	0.120

12 Audio Low-Pass Filter Select (0.13d SPCL). See Service Sheets 12 and 13.

Low-Pass Filter	Direct Control Special Function
3 kHz	0.130
15 kHz	0.13C
>20 kHz	0.13A
All off	0.139

13 Audio High-Pass Filter and FM Pre-Display De-emphasis Control (0.14d SPCL). See Service Sheet 13.

High-Pass Filter	Direct Control Special Function	
	Pre-Display On	Pre-Display Off
300 Hz	0.144	0.14C
50 Hz	0.142	0.14A
All Off	0.141	0.149

14 FM De-emphasis, Phase Modulation, and + or - Peak Detector Control (0.10d SPCL). See Service Sheet 13.

Function	Direct Control Special Function	
	Peak+ Detector	Peak- Detector
De-emphasis off	0.100	0.108
De-emphasis 25 μ s	0.101	0.109
De-emphasis 50 μ s	0.104	0.10C
De-emphasis 75 μ s	0.102	0.10A
De-emphasis 750 μ s	0.103	0.10B
Phase modulation	0.105	0.10D

15 Discharge Absolute Peak Detector. Key in 0.160 SPCL several times. See Service Sheet 13.

16 Voltmeter Peak Detector Control (0.1Ed SPCL). See Service Sheet 14.

Mode	Direct Control Special Function
Slow charge	0.1E3
Fast charge	0.1E1
Very fast charge; hold	0.1E0
Discharge	0.1E0 then 0.1E1

17 Modulation Output/Audio Input Select (0.2Bd SPCL). See Service Sheet 16.

Mode	Direct Control Special Function
Output	0.2B0
Input	0.2B1

18 Distortion Analyzer Control (0.2Ad SPCL). See Service Sheet 16.

Mode	Amplifier 1 Gain	Amplifier 2 Gain	Notch Frequency	Direct Control Special Function
Thru path	0 dB	0 dB	1 kHz	0.2A0
Thru path	20 dB	0 dB	1 kHz	0.2A2
Notch filter	0 dB	0 dB	1 kHz	0.2A1
Notch filter	0 dB	20 dB	1 kHz	0.2A5
Notch filter	0 dB	0 dB	400 Hz	0.2A9

19 Audio Counter Control (0.28d and 0.29d SPCL). The table follows the normal count sequence. See Service Sheet 16. Also see *Readback Control* table.

Operation	Direct Control Special Function
Count Sequence	
Enable inputs of stages 1 and 3	0.296
Reset counter	0.282
Release counter reset	0.28A
Initiate count on next input pulse	0.28E
Initiate count stop on next input pulse	0.28A
Readback Sequence	
Enable readback pulsing of stages 3 and 4	0.288
Disable readback of stages 3 and 4	0.292
Enable readback pulsing of stages 1 and 2	0.28C
Disable readback of stages 1 and 2	0.294

20 Voltmeter Input Select (0.1Cd and 0.1Fd SPCL). See Service Sheet 15.

Selector	Input	Direct Control Special Function
A5U10	Ground	0.1C0 then 0.1F0
A5U10	RF Peak Detector Ground	0.1C0 then 0.1F1
A5U10	RF Peak Detector $\div 3$	0.1C0 then 0.1F2
A5U10	RF Peak Detector	0.1C0 then 0.1F3
A5U10	$\times 10$ AM Calibrator	0.1C0 then 0.1F4
A5U10	$\times 1$ AM Calibrator	0.1C0 then 0.1F5
A5U10	Audio Range Detector	0.1C0 then 0.1F6
A5U10	RMS-to-DC Converter	0.1C0 then 0.1F7
A5U11	Ground	0.1C0 then 0.1F8
A5U11	Audio Average Detector	0.1C0 then 0.1F9
A5U11	Audio Peak Detector	0.1C0 then 0.1FA
A5U11	IF Average Detector	0.1C0 then 0.1FB
A5U11	IF RMS Detector (Opt. Series 030)	0.1C0 then 0.1FC
A5U11	IF Peak Detector	0.1C0 then 0.1FD
A5U11	ALC Current	0.1C0 then 0.1FE
A5U11	Sensor Identifier	0.211, 0.1C0, then 0.1FF
A5U11	RF Average Power	0.212, 0.1C0, then 0.1FF
A5U12	Ground	0.1C4 then 0.1F8
A5U12	-15V Supply	0.1C4 then 0.1F9
A5U12	-5V Supply	0.1C4 then 0.1FA
A5U12	+5V Supply	0.1C4 then 0.1FB
A5U12	+15V Supply	0.1C4 then 0.1FC
A5U12	+40V Supply	0.1C4 then 0.1FD
A5U12	Opt. 020 RMS to DC Converter	0.1C4 then 0.1FE

21 Counter Input Select (0.31d SPCL). See Service Sheet 23.

Input	Direct Control Special Function
High Frequency VCO $\div 8$	0.314
Intermediate Frequency	0.315
Voltage-to-Time Converter or Audio	0.316
FM Calibrator	0.317
Selected Time Base Reference	0.31C
External Time Base Reference	0.31D
Internal Time Base Reference	0.31E

22 Counter Control (0.36d and 0.370 SPCL). See Service Sheet 23. Also see *Readback Control* table.

Function	Direct Control Special Function
Enable low-frequency count; Enable high-frequency count	0.363
Enable low-frequency count; Disable high-frequency count	0.362
Disable low-frequency count; Enable high-frequency count	0.361
Disable counting	0.360
Initialize counter hardware	0.370

23a Selective Power IF Filter, IF Gain, and LO Input Control (2314A to 2636A) (Option Series 030) (0.25d, 0.2Dd, and 0.2Ed SPCL). See Service Sheets 6 and 7. Also see *Readback Control* table.

First Channel Filter	Channel Output Attenuator	Local Oscillator	Direct Control Special Function
Filter 1	20 dB	Internal	.2D0
Filter 1	0 dB	Internal	.2D1
Filter 2	20 dB	Internal	.2D2
Filter 1	20 dB	External	.2D4

Attenuator			Second Channel Filter	Direct Control Special Function
1	2	3		
20 dB	20 dB	20 dB	Filter 1	.250
0 dB	20 dB	20 dB	Filter 1	.251
20 dB	0 dB	20 dB	Filter 1	.252
20 dB	20 dB	0 dB	Filter 1	.254
20 dB	20 dB	20 dB	Filter 2	.258

Attenuator 4	Direct Control Special Function
0 dB	.2E7
5 dB	.2EB
10 dB	.2ED
15 dB	.2EE

23b Selective Power IF Filter, IF Gain, and LO Input Control (2642A and Above) (Option Series 030) (0.39d, 0.3Dd, and 0.3Ed SPCL). See Service Sheets 33 and 34. Also see *Readback Control* table.

First Channel Filter	Channel Output Attenuator	Local Oscillator	Direct Control Special Function
Filter 1	20 dB	Internal	0.3D0
Filter 1	0 dB	Internal	0.3D1
Filter 2	20 dB	Internal	0.3D2
Filter 1	20 dB	External	0.3D4

Attenuator			Second Channel Filter	Direct Control Special Function
1	2	3		
20 dB	20 dB	20 dB	Filter 1	0.390
0 dB	20 dB	20 dB	Filter 1	0.391
20 dB	0 dB	20 dB	Filter 1	0.392
20 dB	20 dB	0 dB	Filter 1	0.394
20 dB	20 dB	20 dB	Filter 2	0.398

Attenuator 4	Direct Control Special Function
0 dB	0.3E7
5 dB	0.3EB
10 dB	0.3ED
15 dB	0.3EE

24 FM Calibrator Control (0.19d SPCL). See Service Sheet 29.

Frequency	Direct Control Special Function
Switching	0.193
High	0.192
Low	0.191

25 AM Calibrator Control (0.18d SPCL). See Service Sheet 30.

Mode		Direct Control Special Function
Channel A	Channel B	
On	Switching	0.184
On	Off	0.186
Off	On	0.181
On	On	0.185
Off	Off	0.183

26 LO Band Control (0.00d SPCL). See Service Sheet 17.

Band Name	LO Output Frequency (MHz)	Direct Control Special Function
DBLR	640-1300	0.00A
0	320-640	0.009
1	160-320	0.008
2	80-160	0.007
3	40-80	0.006
4	20-40	0.005
5	10-20	0.004
6	5-10	0.003
7	2.5-5	0.002
8	1.25-2.5	0.001
Output Disable	No output	0.000

27 **LO Tune Mode Control** (0.01d SPCL). Also key in 0.0FF SPCL to inhibit the sweep current sources. See Service Sheet 20.

Tune Mode	Direct Control Special Function
Close sampler loop; DAC to LF VCXO	0.013
Close sampler loop; DAC off	0.017
Close track loop; DAC to LF VCXO	0.019
Close track loop; DAC off	0.01D
Loops open; DAC to LF VCXO	0.01B
Loops open; DAC to HF VCO	0.01E
Loops open; DAC off	0.01F

28 **LO Sweep and IF Detector Latch Control** (0.0Fd SPCL). See Service Sheets 9 and 20.

Sweep Mode and IF Present Latch Status	Direct Control Special Function
Enable latch to stop sweep down	0.0FF
Sweep down; reset latch	0.0FE
Sweep up; reset latch	0.0F2

29 **LF VCXO and HF VCO Tune Line Filter Control and IF Level Detector Reset** (0.0Fd SPCL). See Service Sheets 9, 20, and 23.

Filter Bandwidth and IF Level Detector Reset	Direct Control Special Function
Narrow filters; detector not reset	0.0F8
Wide filters; detector not reset	0.0FA
Narrow filters; detector reset	0.0F9 then 0.0F8
Wide filters; detector reset	0.0FB then 0.0FA

30 **DAC Setting (LO Frequency Control)** (0.08d to 0.0Bd SPCL). The value of the data (d) determines the output of the DAC. See Service Sheet 20.

Weighting of DAC	Direct Control Special Function
Most significant	0.08d
Second most significant	0.09d
Second least significant	0.0Ad
Least significant	0.0Bd

31 Annunciator and Key Light Control (0.50d to 0.57d SPCL). See Service Sheet 27.

Title	Light Type	Direct Control Special Function
50 Hz	Key Light	0.50F
300 Hz	Key Light	0.50D
3 kHz	Key Light	0.50B
15 kHz	Key Light	0.509
>20 kHz	Key Light	0.507
PEAK+	Key Light	0.505
PEAK-	Key Light	0.503
PEAK HOLD	Key Light	0.501
PRE DISPLAY	Key Light	0.51F
25 μ s	Key Light	0.51D
50 μ s	Key Light	0.51B
75 μ s	Key Light	0.519
750 μ s	Key Light	0.517
ZERO	Key Light	0.515
CALIBRATE	Key Light	0.513
RMS CAL AVG	Key Light	0.511
S (Shift)	Key Light	0.52F
AM	Key Light	0.52D
FM	Key Light	0.52B
Φ M	Key Light	0.529
RF POWER	Key Light	0.527
FREQ	Key Light	0.525
RATIO	Key Light	0.523
TRACK MODE	Key Light	0.521
RANGE HOLD	Key Light	0.53F
(Blue)	Key Light	0.53D
SPCL	Key Light	0.53B
AUDIO INPUT	Key Light	0.539
DISABLE ERROR	Annunciator	0.537
RMS	Annunciator	0.535
dB EXT ATTEN	Annunciator	0.533
AUTO TUNING	Annunciator	0.531
%	Annunciator	0.54F
MHz	Annunciator	0.54D
kHz	Annunciator	0.54B
Hz	Annunciator	0.549
W	Annunciator	0.547
dBm	Annunciator	0.545
dB	Annunciator	0.543
rad	Annunciator	0.541
mV	Annunciator	0.55F
μ V	Annunciator	0.55D
REL	Annunciator	0.55B
V	Annunciator	0.559
400 Hz	Annunciator	0.555
1 kHz	Annunciator	0.553
LIMIT	Annunciator	0.551
RECAL	Annunciator	0.56F
AM	Annunciator	0.56D
FM	Annunciator	0.56B
Φ M	Annunciator	0.569
LISTEN	Annunciator	0.567
TALK	Annunciator	0.565
REMOTE	Annunciator	0.563
SRQ	Annunciator	0.561
UNCAL	Annunciator	0.57F
f OFS	Annunciator	0.573

32 **Display and Decimal Point Control** (0.60d to 0.69d SPCL). See Service Sheet 26.

Digit Number	Direct Control Special Function	Segment Displayed	d
1	0.60d	a	5
2	0.61d	b	3
3	0.62d	c	D
4	0.63d	d	9
5	0.64d	e	F
6	0.65d	f	7
7	0.66d	g	1
8	0.67d	dp	B
9	0.68d		
10	0.69d		

33 **Remote Interface Assembly** (0.400 to 0.474 SPCL). See Service Sheet 28.

Function	Direct Control Special Function
Clear DAC Flip-Flop.	0.400
Clear Talk and Listen Address Flip-Flops.	0.410
Set Talk, clear Listen Address Flip-Flops.	0.411
Clear Talk, set Listen Address Flip-Flops.	0.412
Set Talk and Listen Address Flip-Flops*.	0.413
Clear Remote Enable (REN) Flip-Flop.	0.420
Set Remote Enable (REN) Flip-Flop.	0.424
Allow Interface Control ROM to be disabled.	0.430
Allow Interface Control ROM to be enabled.	0.440
Clear Serial Poll Flip-Flop.	0.470
Set Serial Poll Flip-Flop (unless IFC true).	0.474
* Disables instrument. Re-establish control by turning the instrument to STBY, then to ON, or by issuing the Local message via the HP-IB.	