

# Keysight Technologies N7784B High Speed Polarization Controller

Data Sheet



## Introduction

The Keysight Technologies N7784B polarization controller contains a high-speed polarization controller plus microcontroller-based driving circuitry. This unit can operate in various modes.

As a polarization stabilizer, it provides a stable output state of polarization (SOP) even with fluctuations and drifts of the input SOP as occurring for example through temperature drift and mechanical settling processes. The stabilized output signal is aligned into a polarization maintaining fiber (PMF). Alternatively, an external electrical feedback signal can be provided for stabilizing the SOP.

As a synchronous scrambler, the device switches the SOP of the output signal in a random (pseudo) way. Switching of the SOP occurs within a few microseconds. The SOP is stable for a predefined time until it again switches to a new SOP. An electrical trigger input can be used to synchronize the scrambler with external events.

As an SOP switch, the N7784B allows switching the internal waveplates to user definable angles with very high speed and repeatability.

As traditional scrambler the N7784B varies the output SOP smoothly in a random/pseudo random way. The unit does not contain any moving parts and therefore is robust and withstands even rough environmental conditions. All above-mentioned applications of the N7784B are supported by a PC software package.

- PC-based application software comes with this instrument.
- Other instrument drivers for various software interfaces are available.

### Key Benefits

- Comprehensive polarization control and management capabilities.
- Covers S-, C- and L-band plus 1.3  $\mu\text{m}$  window (O-band).
- Compact size.
- Standalone operation.
- Robust, no moving parts.
- PC software package included.

## Applications

- Interferometry: polarization stabilization to maximize contrast ratio.
- Recirculating loop experiments: loop-synchronous polarization scrambling.
- System test: polarization sensitivity analysis on link/transmission quality.

## Keysight N7784B instrument setup and application examples

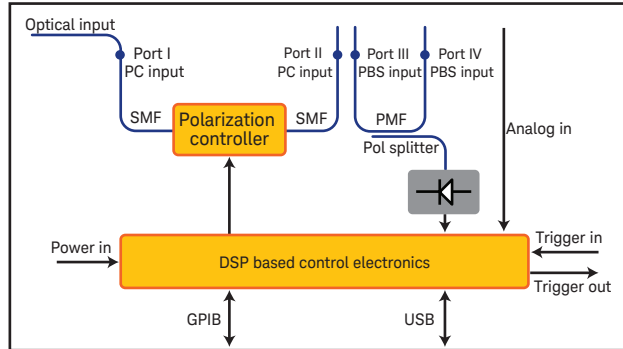

Figure 2. N7784B instrument setup.

The instrument setup is shown in Figure 2. If a scrambling or switching operation is desired, only ports I and II are used. If the SOP of the signal is stabilized and the signal is fed in a PMF, then port II and port III have to be connected by an SMF. In this situation, the output signal is available on port IV. If an external feedback signal is available for stabilization, only ports I and II are occupied.

## Application examples

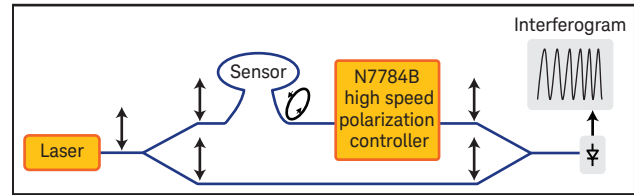

Figure 3. Interferometry/coherent detection.

Fiber optic based interferometers or coherent receiver schemes need polarization stabilization in order to avoid fading effects of the interference signal. These fading effects are caused by orthogonally polarized fractions of the light. The N7784B allows elimination of such effects by alignment of the signal polarization.

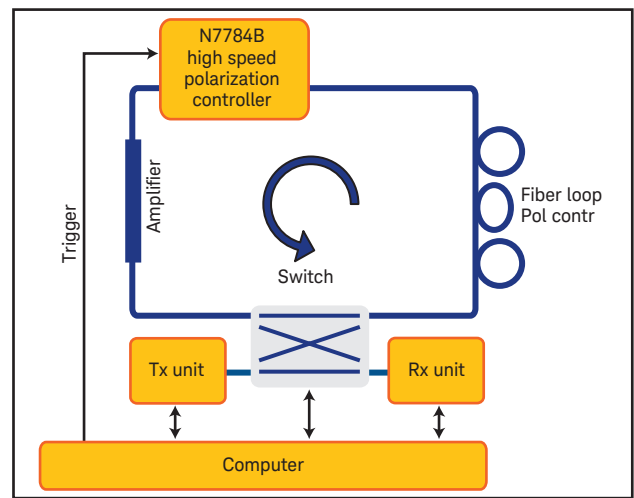

Figure 4. Recirculating loop.

The results obtained in re-circulating loop experiments depend heavily on the PMD and PDL properties of the loop.

Loop synchronous polarization scrambling schemes have proven to be necessary for generating results comparable to deployed systems. The N7784B is ideally suited to provide the synchronous scrambling capability in such experiments.

<b>Specifications <sup>1</sup> N7784B Polarization Controller</b>		
<b>Wavelength</b>		
Operating wavelength range	1260 nm to 1640 nm	
Wavelength range in stabilizer mode <sup>2</sup>	1520 nm to 1580 nm	
<b>Polarization control and stabilization</b>		
SOP switching time (open-loop)	< 10 $\mu$ s	
PER at PMF output (typical)	> 23 dB	
Stabilizer response time (typical) <sup>3</sup>	2 ms	
<b>Optical power</b>		
Insertion loss port I to port II <sup>4</sup>	< 3.5 dB (< 3.0 dB, typical)	
Insertion loss port III to port IV <sup>5</sup>	< 1.8 dB (< 1.4 dB, typical)	
PDL port I to port II (typical)	C/L-Band	< 0.2 dB
	O-Band	< 0.5 dB
Maximum safe input power	Port I	20 dBm
	Port III	3 dBm
Input power range in stabilizer mode	Port III	-30 dBm to 0 dBm
<b>Ordering instructions</b>		
<b>Optical connector options</b>		
N7784B-021	Straight contact connectors	
N7784B-022	Angled contact connectors	
<b>Connector interface</b>		
The N7784B should usually be ordered with four 81000xl connector interfaces, depending on desired connector type (not included).		
<b>Accessories</b>		
5063-9240	Rack mount kit for 1 unit with filler panel	
5063-9212 + 5061-9694	Rack mount parts for 2 units side-by-side	
<b>Warranty</b>		
<b>Select coverage</b>		
Included	3-year warranty (return to Keysight), standard	
R-51B-001-5Z	5-year warranty assurance plan (return to Keysight): Priority warranty service includes one-time coverage for an EOS/ESD failure.	
<b>Calibration</b>		
<b>Select Keysight calibration plan</b>		
R-50C-011-3	3-year calibration assurance plan (return to Keysight): Priority calibration service covering all calibration costs for 3 years; 15% cheaper than buying stand-alone calibrations.	
R-50C-011-5	5-year calibration assurance plan (return to Keysight): Priority calibration service covering all calibration costs for 5 years; 20% cheaper than buying stand-alone calibrations.	

1. Ambient temperature change max.  $\pm 0.5$  °C since normalization. Specification valid on day of calibration.

2. Outside the stabilizer wavelength range, the PER at PMF output may be degraded.

3. Input power at port III > -30 dBm, response to an immediate step of 180° on the Poincaré sphere.

4. For SOP scrambling/switching, only ports I/II are used.

5. Valid for optimum input polarization at PBS input (Port III). Add insertion loss of port I/II and obtain total insertion loss for SOP stabilizing mode.

**Specifications N7784B Polarization Controller (continued)****General characteristics**

Dimensions (D x W x H)	380 mm x 213 mm x 88 mm (excluding front and back rubber cushions and handle)
Weight	Approx. 4 kg
Recommended recalibration period	24 months
Operating temperature	+5 °C to +40 °C
Operating humidity	0% to 80%, non-condensing
Altitude	The maximum operating altitude is 2000 m.
Pollution protection	Pollution degree 2.
Warm-up time	20 minutes
Interfaces	The instruments can be controlled via USB or GPIB interfaces
Power consumption	Line power: AC 100 to 240 V $\pm$ 10%, 50/60 Hz, 60 VA max.

## myKeysight

### myKeysight

[www.keysight.com/find/mykeysight](http://www.keysight.com/find/mykeysight)

A personalized view into the information most relevant to you.



### Three-Year Warranty

[www.keysight.com/find/ThreeYearWarranty](http://www.keysight.com/find/ThreeYearWarranty)

Keysight's commitment to superior product quality and lower total cost of ownership. The only test and measurement company with three-year warranty standard on all instruments, worldwide.



### Keysight Assurance Plans

[www.keysight.com/find/AssurancePlans](http://www.keysight.com/find/AssurancePlans)

Up to five years of protection and no budgetary surprises to ensure your instruments are operating to specification so you can rely on accurate measurements.



[www.keysight.com/quality](http://www.keysight.com/quality)

Keysight Electronic Measurement Group

DEKRA Certified ISO 9001:2008

Quality Management System

### Keysight Channel Partners

[www.keysight.com/find/channelpartners](http://www.keysight.com/find/channelpartners)

Get the best of both worlds: Keysight's measurement expertise and product breadth, combined with channel partner convenience.

For more information on Keysight Technologies' products, applications or services, please contact your local Keysight office. The complete list is available at: [www.keysight.com/find/contactus](http://www.keysight.com/find/contactus)

### Americas

Canada	(877) 894 4414
Brazil	55 11 33 51 7010
Mexico	001 800 254 2440
United States	(800) 829 4444

### Asia Pacific

Australia	1 800 629 485
China	800 810 0189
Hong Kong	800 938 693
India	1 800 112 929
Japan	0120 (421) 345
Korea	080 769 0800
Malaysia	1 800 888 848
Singapore	1 800 375 8100
Taiwan	0800 047 866
Other AP Countries	(65) 375 8100

### Europe & Middle East

Belgium	32 (0) 2 404 93 40
Denmark	45 45 80 12 15
Finland	358 (0) 10 855 2100
France	0825 010 700*
	*0.125 €/minute
Germany	49 (0) 7031 464 6333
Ireland	1890 924 204
Israel	972-3-9288-504/544
Italy	39 02 92 60 8484
Netherlands	31 (0) 20 547 2111
Spain	34 (91) 631 3300
Sweden	0200-88 22 55
United Kingdom	44 (0) 118 927 6201

For other unlisted countries:

[www.keysight.com/find/contactus](http://www.keysight.com/find/contactus)

(BP-04-23-14)