

Keysight M9185A

PXI Isolated D/A Converter

8/16-Channel 16-bit, ± 16 V

Data Sheet



Overview

Introduction

The Keysight Technologies, Inc. M9185A is a digital/analog converter (D/A converter) which has eight or 16 independent, isolated channels capable of supplying high voltage levels in parallel as stimulus signals to the device-under-test (DUT), making it ideal for automated test equipment (ATE) in automotive electronics.

Product description

The M9185A is a 2- or 3-slot, PXI based, D/A converter with 16-bit resolution that is capable of providing DC voltages as stimulus to the device-under-test (DUT). The M9185A comes in eight or 16 channel option, where the eight-channel option is a 2-slot size module and the 16-channel option is a 3-slot size module. Each channel in the M9185A D/A converter is capable of supplying voltages between -16 V DC and +16 V DC at 500 μ V resolution. Each channel can also generate currents of between -20 mA and +20 mA at 630 nA resolution.

The M9185A D/A converter comes with a built-in hardware remote SENSE feature which acts as a mechanism to detect the output voltage levels and feeds the information back to the compensation circuitry of the converter. It will then use this information to auto adjust its voltage outputs to achieve the desired voltage levels. Additionally, the M9185A D/A converter is capable of providing output to a maximum level of ± 16 V per channel.

With the ability to achieve ± 16 V output voltage levels and a remote SENSE feature to guarantee that good accuracy is achieved, the M9185A is an ideal module for the automotive industry since most automotive applications require accurate voltage levels between 12 V to 14 V in order to operate the DUT.

NOTE: To ensure that an accurate voltage is present at the loads, it is recommended that you use remote sensing. However, if remote sensing is not used, do not connect loads or cables to the remote sensing terminals (H Sense and L Sense).

Applications

- Automotive electronics test
- Functional test systems requiring isolated biasing channels
- ATE requiring remote sensing

Features

- Eight or 16 Isolated Channels
- Output up to ± 16 V DC or ± 20 mA DC
- 16-bit resolution
- Isolation: > 80Vdc/ac peak (channel-to-chassis or channel-to-channel)
- Synchronization: Software commands or external trigger
- Remote SENSE feature for accurate output levels (4-wire)
- Interface connector compatibility with cPCI, PXI-H, PXI-1
- Output connection using stacked VHDCI receptacle
- IVI-COM, IVI-C, LabVIEW G drivers

Customer values

- High output voltage levels up to ± 16 V for wider range of stimulus voltages
- No pull up circuit required to achieve automotive voltage requirements of 12 V to 14 V
- Remote SENSE feature for accurate output voltages



Easy Setup ... Test ... and Maintenance

Hardware platform

Compliance

The M9185A D/A converter is PXI compliant, using either a cPCI, PXI-1 or PXI Hybrid slot. The product can be integrated with other test and automation modules in cPCI, PXI-1 and PXI-H chassis (hybrid slots). The PXI format offers high performance in a small, rugged package. It is an ideal deployment platform for many automated test systems. A wide array of complementary PXI products is currently available. Products include multimeters, waveform generators, local oscillators, digitizers, down converters and switch multiplexers.

Remote SENSE mechanism

The precision of the output voltages from D/A converters cannot always be guaranteed since there is no way to instantly obtain the voltage levels at the receiving end of a DUT. Unless a DMM is utilized to measure the voltage and manual adjustment is made, there is always an uncertainty of the output voltage levels from the D/A converters.

The M9185A's SENSE mechanism acts as a feedback feature to auto trigger the D/A converter to adjust the voltage levels to achieve better accuracy at the receiving end of a DUT. Figure 1 shows a simplified illustration of how the SENSE mechanism works. The R is actually the path resistance, or may be the lead resistance, without sense, the DMM may only sense D/A converter OUTPUT-R. For instant, the D/A converter outputs 16 V, but DMM may only sense 15.5 V. So the SENSE mechanism will increase the voltage by triggering the D/A converter to increase up to 16.5 V; therefore what the DMM now measures is 16 V.

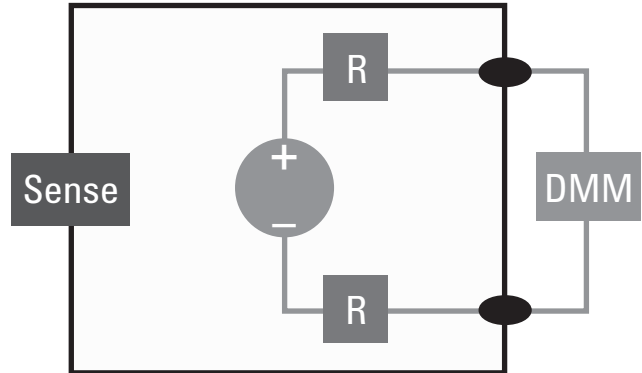

Figure 1. Basic example of the SENSE mechanism

Using the Remote SENSE

When using the remote sensing feature, connect sense wires from the load to the High Sense and Low Sense terminals for the desired channels. When outputting current the High Sense and Low Sense terminals are not used and are opened. For protection, each channel incorporates a fuse that will open at greater than 20 mA. If an overload condition exists, the fuse will open, but no error will be generated. To reset the fuse, remove the overload and wait a few minutes for the fuse to cool.

Software platform

IO libraries

Keysight IO Libraries Suite offers FAST and EASY connection to instruments and the newest version extends that capability to include modular instruments.

NEW support for PXI — The Keysight IO Libraries Suite helps you display ALL of the modules in your system. From here you can view information about the installed software or start the modules' soft front panel. Launch the modules' soft front panel directly from Keysight Connection Expert.

Drivers

The M9185A D/A converter is supplied with a comprehensive portfolio of module drivers, documentation, examples, and software tools to help you quickly develop test systems with your software platform of choice. The module comes with IVI-COM, IVI-C, and LabVIEW G software drivers that work in the most popular test and measurement development environments including LabVIEW and LabWindows/CVI from National Instruments, Microsoft C/C++, C#, and VB.NET.

Easy Software Integration

The module software support provides context sensitive help, complete documentation and code examples that allow a quick module set up and basic acquisition functionalities. These code examples can be easily modified, so that the card can be quickly integrated into a test system. Included are application code examples for LabVIEW, LabWindows/CVI, Visual Studio C, C++, and C# and Visual Basic.

Calibration intervals

The M9185A is factory calibrated and shipped with a calibration certificate. Calibration is recommended every year in order to verify product performance.

Technical Specifications

DAC specifications	
Number of Channels	8 or 16 channels
Resolution	16-bit
Isolation	> 80 Vdc/ac peak (channel-to-chassis or channel to channel)
Synchronization	Software commands or external trigger.
Settling Time	500 μ s (typical)
DC Voltage	
Range	± 16 V up to 10 mA
Resolution	16-bit = 500 μ V
Accuracy	$\pm (0.05\% + 3.0$ mV)
Ripple and Noise	< 80 mVpk-pk (typical)
DC Current	
Range	± 20 mA
Resolution	16-bit = 630 nA
Accuracy	$\pm (0.09\% + 5.0$ μ A)
Ripple and Noise	< 2 μ Arms (typical)
I/O Trigger Characteristics	
Trigger Input:	
Input Level	TTL compatible (3.3 V logic, 5 V tolerant)
Slope	Rising or falling (selectable)
Pulse Width	> 100 nS
Input Impedance	> 10 k Ω typical, DC coupled
Trigger Output:	
Level	TTL compatible into 1 k Ω (3.3 V logic)
Output Impedance	50 Ω typical

General Specifications

Environmental and physical	
Operating temperature	0 to 55° C
Storage temperature	–40 °C to 70° C
Relative humidity	80%, 0° C to 40° C (non condensing)
Altitude	10,000 ft (Operating)/15,000 ft (Non-operating)
Dimensions	8-channel: 40.30 mm x 128.40 mm × 215.00 mm 1.59 in × 5.06 in × 8.46 in 16-channel: 60.50 mm x 128.40 mm × 215.00 mm 2.38 in × 5.06 in × 8.46 in
Weight	8-Channel; 0.47 kg (1.04 lb) 16-Channel; 0.60 kg (1.32 lb)
Output connector	Stacked VHDCI receptacle
CE mark compliance	2006/95/EC; 2004/108/EC
Safety	Pollution degree 2
EMC immunity	EN/IEC 61326-1 industrial environment
EMC emissions	EN/IEC 61326-1 Class A
Warm-up time	30 minutes
Additional information	
Recommended calibration interval	1 Year
Configuration	
Hardware	
M9185A ¹	M9185A PXI 8/16-channel D/A converter
Related products	
Software	
Keysight IO libraries ²	Keysight IO Libraries Drivers, soft front panels and programming examples in LabVIEW, LabWindows/CVI, Visual Studio C, C++ and C#, Visual Basic, and MATLAB
Accessories	
M9185A-CD1	Software and product information on CD

1. For the M9185A to work properly, at least one PXI chassis and one PXI controller type must be available.
2. Keysight IO Libraries Suite 16.0 is required. The modular product won't work with Keysight IO Libraries Suite versions earlier than version 16.0.

Ordering

Model	Description
M9185A	M9185A PXI Digital to analog converter, 8/16-Channel, 16-bit, 16V

Warranty and Calibration

Advantage services: calibration and warranty

Keysight Advantage Services is committed to your success throughout your equipment's lifetime.

Warranty	Description
Standard warranty is 1 year	
R-9MB-001-3C	1 year return-to-Keysight warranty extended to 3 years
R-9MB-001-5C	1 year return-to-Keysight warranty extended to 5 years

Definitions for specifications

Specification (spec):

Represents warranted performance of a calibrated instrument that has been stored for a minimum of two hours within the operating temperature range of 0 to 40° C, unless otherwise stated, and after a 45-minute warm-up period. The specifications include measurement uncertainty. Data represented in this document are specifications unless otherwise noted.

Typical (typ):

Represents characteristic performance, which 80% of the instruments manufactured will meet. This data is not warranted, does not include measurement uncertainty, and is valid only at room temperature (approximately 25° C).

Nominal (nom):

The expected mean or average performance, or an attribute whose performance is by design, such as the 50 Ω connector. This data is not warranted and is measured at room temperature (approximately 25° C).

Measured (meas):

An attribute measured during the design phase for purposes of communicating expected performance, such as amplitude drift vs. time. This data is not warranted and is measured at room temperature (approximately 25° C).

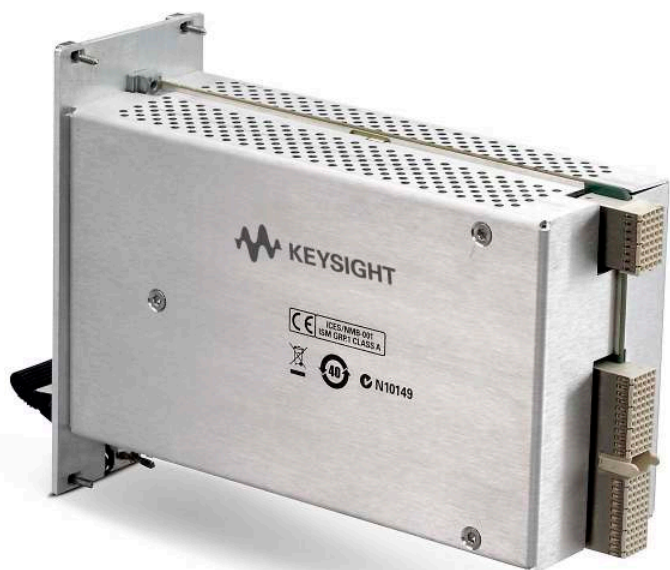

myKeysight

myKeysight

www.keysight.com/find/mykeysight

A personalized view into the information most relevant to you.



www.axiestandard.org

AdvancedTCA® Extensions for Instrumentation and Test (AXIe) is an open standard that extends the AdvancedTCA for general purpose and semiconductor test. Keysight is a founding member of the AXIe consortium. ATCA®, AdvancedTCA®, and the ATCA logo are registered US trademarks of the PCI Industrial Computer Manufacturers Group.



www.pxisa.org

PCI eXTensions for Instrumentation (PXI) modular instrumentation delivers a rugged, PC-based high-performance measurement and automation system.

Three-Year Warranty

www.keysight.com/find/ThreeYearWarranty

Keysight's commitment to superior product quality and lower total cost of ownership. The only test and measurement company with three-year warranty standard on all instruments, worldwide.



Keysight Assurance Plans

www.keysight.com/find/AssurancePlans

Up to five years of protection and no budgetary surprises to ensure your instruments are operating to specification so you can rely on accurate measurements.



Keysight Channel Partners

www.keysight.com/find/channelpartners

Get the best of both worlds: Keysight's measurement expertise and product breadth, combined with channel partner convenience.

www.keysight.com/find/modular

www.keysight.com/find/m9185a

For more information on Keysight Technologies' products, applications or services, please contact your local Keysight office. The complete list is available at: www.keysight.com/find/contactus

Americas

Canada	(877) 894 4414
Brazil	55 11 3351 7010
Mexico	001 800 254 2440
United States	(800) 829 4444

Asia Pacific

Australia	1 800 629 485
China	800 810 0189
Hong Kong	800 938 693
India	1 800 112 929
Japan	0120 (421) 345
Korea	080 769 0800
Malaysia	1 800 888 848
Singapore	1 800 375 8100
Taiwan	0800 047 866
Other AP Countries	(65) 6375 8100

Europe & Middle East

Austria	0800 001122
Belgium	0800 58580
Finland	0800 523252
France	0805 980333
Germany	0800 6270999
Ireland	1800 832700
Israel	1 809 343051
Italy	800 599100
Luxembourg	+32 800 58580
Netherlands	0800 0233200
Russia	8800 5009286
Spain	0800 000154
Sweden	0200 882255
Switzerland	0800 805353
	Opt. 1 (DE)
	Opt. 2 (FR)
	Opt. 3 (IT)
United Kingdom	0800 0260637

For other unlisted countries:
www.keysight.com/find/contactus
 (BP-07-10-14)