

Keysight Technologies Reliable High-Resistance Measurements Using the B2985A/87A

Electrometer/High Resistance Meter

Technical Overview



Introduction

Previously, high resistance and resistivity measurements have required extensive measurement expertise in order to obtain accurate results. This is primarily due to the nature of very low current measurements, which are extremely sensitive to a variety of environmental factors. Typical sources of error include: leakage currents, discharge or absorption currents, test device grounding/floating issues, and environmental noise arising from the test device's physical dimensions.

The Keysight Electrometer/High Resistance Meter (B2985A/B2987A) provides both impressive 10 aA (0.01 fA) minimum current resolution and 10 PΩ (10¹⁶ Ω) resistance measurement capability. In addition, it provides many additional features to improve measurement confidence such as histogram and trend graph views and intuitive measurement navigation.

The histogram and trend (Roll View) graph views provide a quick overview of the measurement status, allowing you to fix any test issues immediately. The measurement navigation aids help you to setup the correct measurement parameters even if you are a novice user.

This technical overview explains how easy it is to make an accurate high-resistance measurement using the B2985A/87A.

Note: The B2987A has an internal rechargeable battery that allows it to operate without being connected to AC power.

Keysight B2985A/87A Measurement Resources

Figure 1 shows a schematic of the B2985A/87A's measurement resources; these consist of one voltage source (Vs), one ammeter and one voltmeter. By default, at boot-up the measurement common (Common) of the ammeter and the voltmeter are connected to the low side of the voltage source (Vs Low). However, a simple command allows you to disconnect the Vs Low terminal from the circuit common using an internal switch (the Vs low terminal connection switch). This means that the voltage source (Vs) and the ammeter/voltmeter resources can be used independently of one another.

Note: The ability to float the measurement common adds flexibility to the instrument and allows it to cover a wider range of applications.

Important words used in the document:

Prefix in the metric system used in very low current:

- - peta (P)= 10¹⁵
- - tera (T)= 10¹²
- - giga (G)= 10⁹
- - pico (p)= 10⁻¹²
- - femto (f)= 10⁻¹⁵
- - atto (a)= 10⁻¹⁸

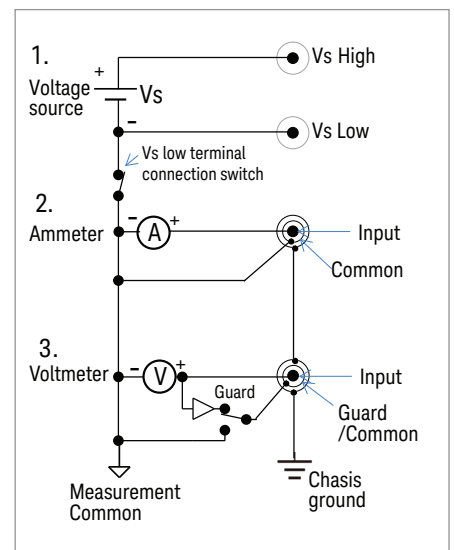

Figure 1. B2985A/87A measurement resources.

High Resistance Measurement Basics

1. Floating and Grounded measurements

As shown in Figure 2, the B2985A/87A has two high-resistance measurement configurations (floating and grounded) to support both of these test device situations. Figure 2(a) shows the case where the device under test (DUT) is floating with respect to earth ground. In this situation the resistance between the high terminal and the low terminal is measured. Note that although the low side is floating, parasitic resistances and capacitances may provide a “sneak path” to ground. This situation is still OK if a DC bias source is connected to the low terminal. Figure 2(b) shows the case where the DUT is grounded. Since the low side is grounded, the test voltage application and the current measurement must both occur at the DUT’s high side terminal.

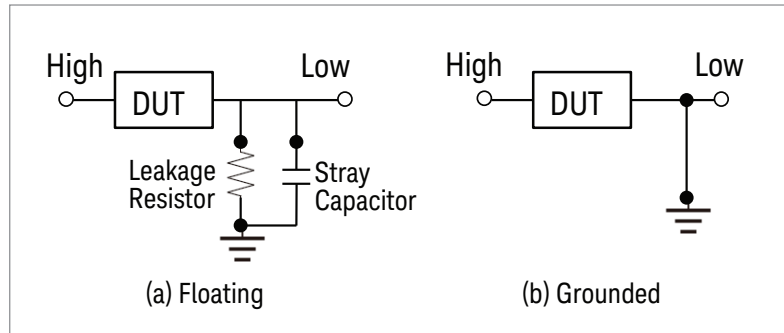

Figure 2. Examples of floating and grounded measurements.

Figure 3 shows a simplified circuit block diagram of the B2985A/87A’s two measurement modes.

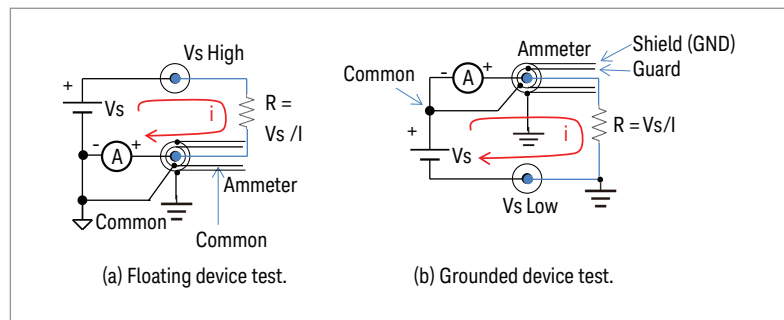

Figure 3. High-resistance measurement mode.

Floating device measurement

Figure 3(a) shows the circuit diagram that corresponds to a floating device measurement. The test device is connected between the Vs High output and the Ammeter input. Since the Ammeter measures very low currents and is very noise-sensitive, it is located close to ground potential to shield the test device for better measurement results.

Grounded device measurement

Figure 3(b) shows the circuit diagram that corresponds to a grounded device measurement. In this configuration, the Ammeter is connected to the Vs positive output because the device is grounded on one side.

The architecture shown in Figure 1 makes it easy to implement either of these configurations. The Ammeter’s input is triaxial, with an inner shield that acts as a guard and an outer shield that is connected to ground. *Note: Although the maximum guard potential is 500 V, measurements can be safely performed as long as proper precautions are taken.* Therefore, it is easy to see that the B2985A/87A’s floating and grounded measurement configuration can cover a wide range of high-resistance measurement applications.

2. Measurement support functionality and tips

High-resistance measurements need to be performed for a wide variety of applications that include materials characterization, component test, finished product evaluation and even equipment maintenance. Unfortunately, many of these applications do not involve measuring a pure resistance because of the presence of parasitic components such as parallel capacitances, leakage resistances and noise receptive antenna elements. Therefore, making accurate high-resistance measurements requires some expertise as to how to use the features of a measurement instrument to eliminate the influence of these parasitic elements.

The following sections explain the techniques necessary to make accurate high-resistance measurements.

Roll view and Real-time histogram facilitate the analysis of noisy data

Often times it is impossible to completely eliminate measurement noise. Therefore, it is important to understand the nature of the noise to select an effective solution. Figure 4 shows how the B2985A/87A's graphical display capabilities can display line frequency noise interference. Figure 4(b) shows how the B2985A/87A can both display a numeric value (Meter view) and the data trend (Roll View) simultaneously. Figure 4(c) shows the B2985A/87A's Histogram View which permits the real-time statistical analysis of measurement data.

The B2985A/87A provides two methods to eliminate noise from a measurement signal: measurement speed and filtering. For measurement speed, there are four choices; Quick, Normal, Stable and Manual. The Manual speed setting is user definable.

Note: The filtering capability is described in a later section.

The Roll View data shown in the first half of the Figure 4(b) graph was taken using the Quick speed measurement setting and it is noisy. The data in the second half of the Figure 4(b) graph was taken using the Normal speed measurement setting and it is stable. The Figure 4(c) Histogram View shows the distributions corresponding to the two data sets shown in Figure 4(b). The histogram distribution of the data taken using the Fast speed setting exhibits a typical sine wave signature, which implies that power line cycling is the main source of noise. The histogram distribution of the data taken using the Normal speed setting (which integrates over the line frequency) exhibits extremely high repeatability, indicating that the Normal speed effectively eliminates the noise. Once you understand the source of the noise, you can decide between reducing the noise at the source or filtering the noise from the measurement data. Note that you can use the histogram data's average value if the noise is symmetrically distributed.

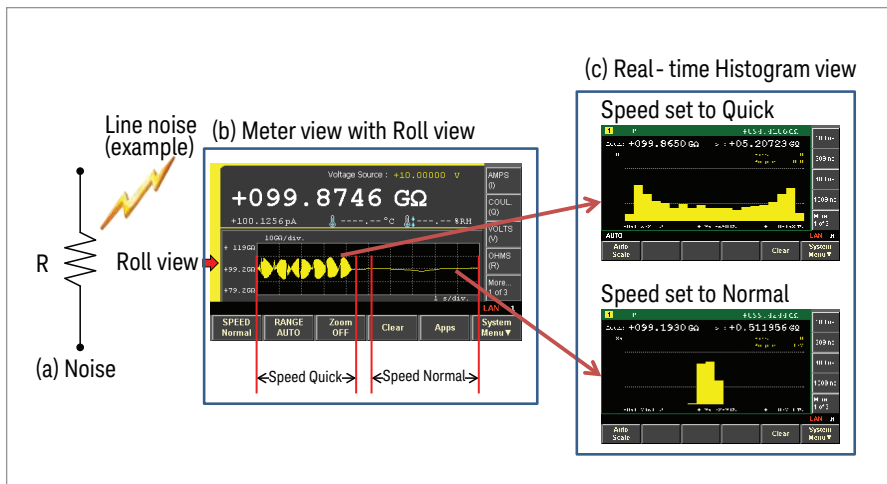

Figure 4. Noise source analysis can be made at a glance using the View functionality.

X-Y graph allows visual determination of data convergence

Figure 5 shows some examples of the parasitic components that can affect high-resistance measurements. In Figure 5(a) the stray capacitor connected in parallel to the resistor increases the response time required to converge to the final resistance value. Figure 5(b) shows an insulation resistance measurement example where capacitive dielectric absorption also increases the convergence time. Figure 5(c) shows that high-resistance components typically exhibit voltage dependency. Observing these changes with a digital display to determine when they converge is not easy. Figure 6 shows how the B2985A/87A's Graph View provides a convenient means to monitor data convergence. This example shows a 100 GΩ resistance measurement transient converging to its final value after application of the test voltage. By showing the convergence response graphically, it is easy to visually determine when the measurement is stable. The dependence of the resistance value on voltage can also be measured in the same way.

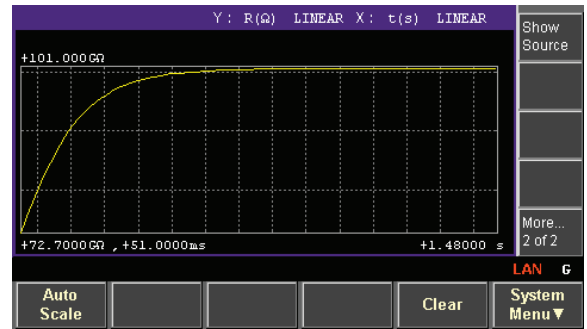

Figure 6. Graph view provides quick visual determination of resistance convergence

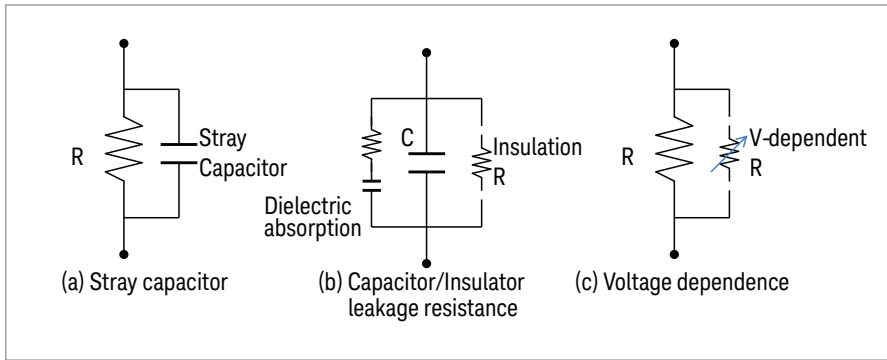

Figure 5. Examples of parasitic components encountered when measuring high-resistance devices.

Guarding is effective to eliminate surface leakage currents

Figure 7(a) shows how surface leakage affects a very high-resistance measurement. If the surface is contaminated (for example through hand contact) then current leakage paths can be created that cause measurement inaccuracy. However, if a guard connection is available as shown in Figure 7(b) then a point on the surface can be connected to the guard of the Ammeter and the error caused by the surface leakage can be eliminated. Because the guard potential almost exactly tracks the center signal pin, the potential between the Ammeter input and the guard is negligible. Therefore, the current flowing from the Ammeter to the guard is almost zero since the surface leakage resistance is very large. *Note: It is very important for the guard potential to closely track the ammeter input voltage for effective guarding. The B2985A/87A guarantees tracking to 20 μV or less in the low current measurement range.*

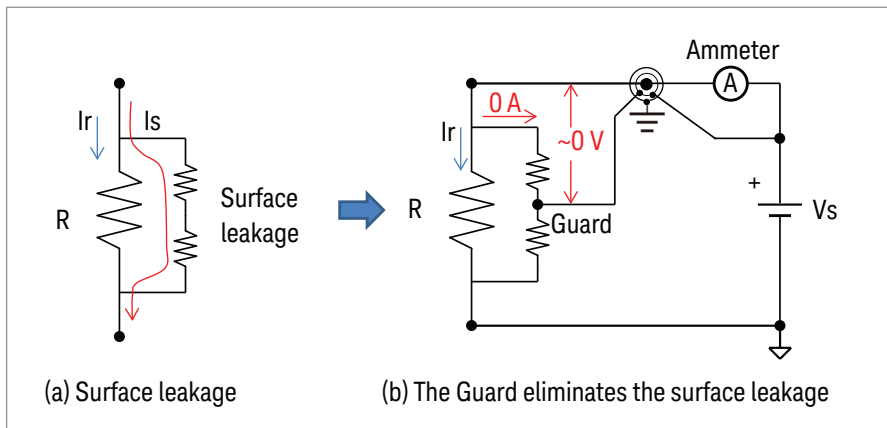

Figure 7. Example showing the equivalent circuit of a high-resistance device.

High Resistance Measurement Example

You can download the test setup of the following examples from the next link;
www.keysight.com/find/SensitiveMeasurements

Example 1. Floating resistance measurement

The following section describes how to setup and measure resistance. This example uses the Keysight N1422A High Value Resistance Box which has a 100 GΩ (1E11 Ω) value. The test setup and the test resources block diagram are shown in Figure 8. The measurement conditions used in this example are as follows.

Test voltage: 10 V

Current range: 200 pA range (i.e. $I = V/R = 10/1E11 = 1E-10 = 100 \text{ pA}$)

Note 1: Since auto range mode is being used for the current measurement, it is not necessary to specify a current measurement range.

Note 2: If your device is grounded, please refer to example 2.

Follow the following steps to setup and measure a high resistance resistor.

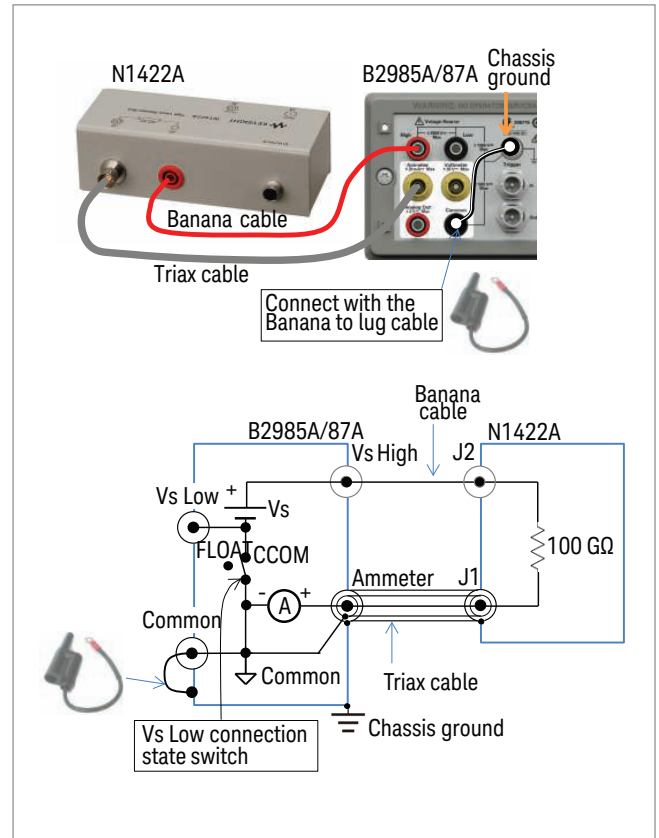
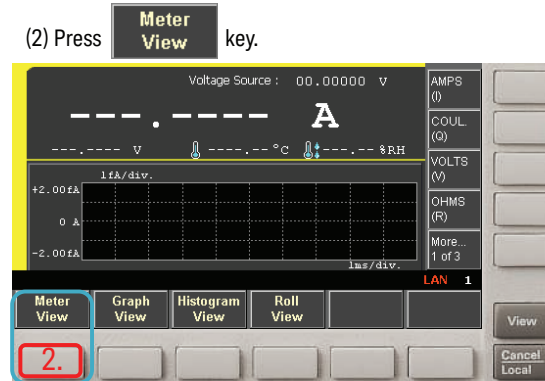
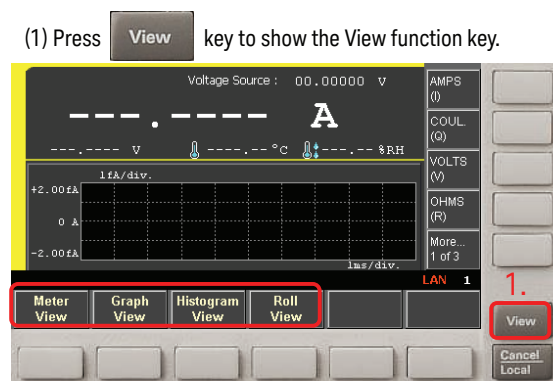

Figure 8. High-resistance measurement cable connections and the test resources block diagram (Floating).

Measurement steps on B2985A/87A front panel operation

1. Press the [View] key to show the View menus in the function key. Then, press the [Meter View] function key.



High Resistance Measurement Example

Measurement steps on B2985A/87A front panel operation

2. Press and select the [OHMS (R)] assist key, then press [More] assist key to show [More 2 of 3] assist key menu. Press and then select [Hide Roll] assist key to close Roll View shown in lower half of the Meter View.

(1) Press **OHMS (R)** key.

(2) Press **More... 1 of 3** key until **More... 2 of 3** key shows up.

(3) Press **Hide Roll** key.

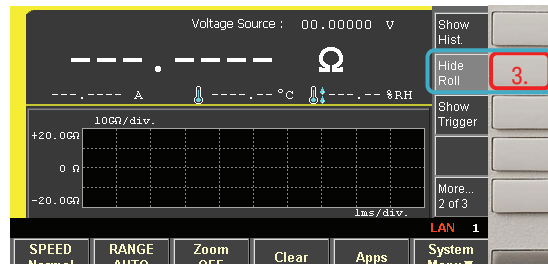
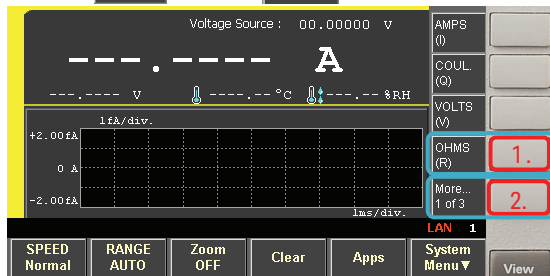

3. The range setups of the resistance measurement mode are displayed. Make sure the measurement range is set to AUTO, and the Spot Source Range is 20 V.

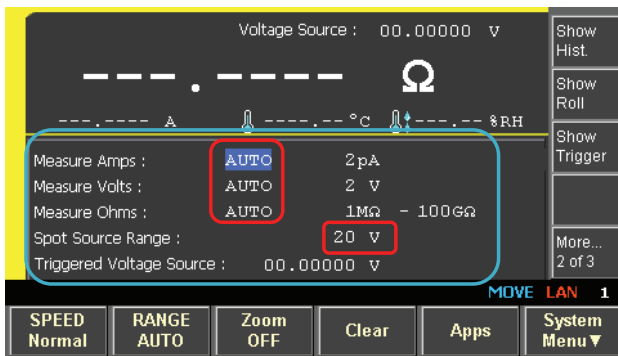

4. Rotate [Knob] to move the field pointer onto the Voltage Source value, and press [Knob] to edit the voltage. The field pointer on the Voltage Source value changes to green (EDIT) and the status information will change from MOVE to EDIT.

Rotate  and move the field pointer onto the Voltage Source value, and press to edit the voltage.

Changed to EDIT mode.

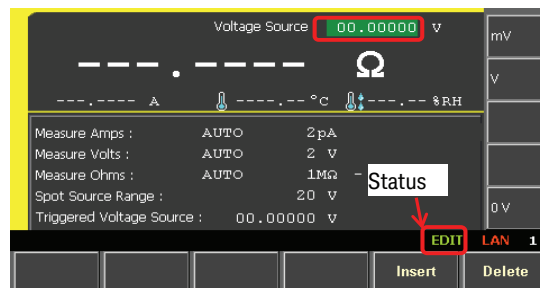
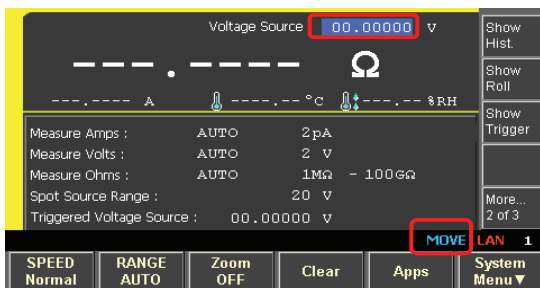



High Resistance Measurement Example *continued*

Measurement steps on B2985A/87A front panel operation

5. Press [Left-Arrow] key to set the voltage digit-to 10 V position. Then rotate [Knob] and set the voltage to 10 V, and press [Knob] to fix the voltage.

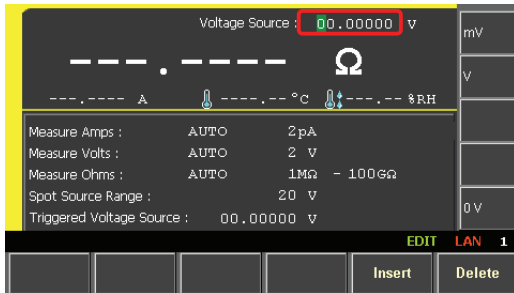
Press  key and move the edit digit to 10 V range.



Rotate  and set to 10 V, then press  to fix the voltage.

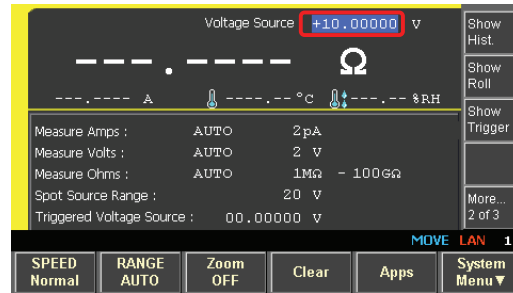

6. Press the Voltage Source [On/Off] key to output the 10 V, and then press the Ammeter [On/Off] key to make measurement.

2. Ammeter On

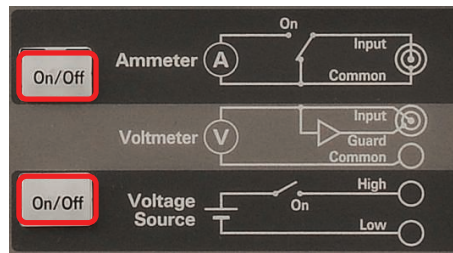

1. Voltage Source On



7. Press the [Run/Stop] key to start continuous resistance measurement. The AUTO indicator shows that the measurement is repeating in AUTO mode.



Note: If you press the [Single] key, the measurement will be made one time only. The "ARM" indicator is shown while the measurement is being made.

High Resistance Measurement Example *continued*

Measurement steps on B2985A/87A front panel operation

8. Both the Roll View and the Histogram View can be displayed inside the Meter View or in the independent View as shown below.

Pressing **Show Roll** assist key opens Roll View in lower half in the Meter View.

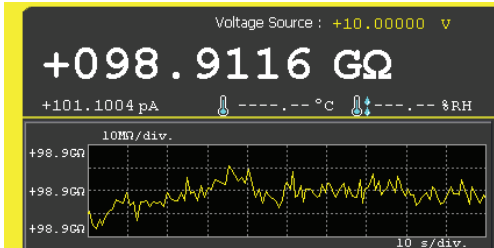

Pressing **Show Hist.** assist key opens Histogram View in lower half in the Meter View.

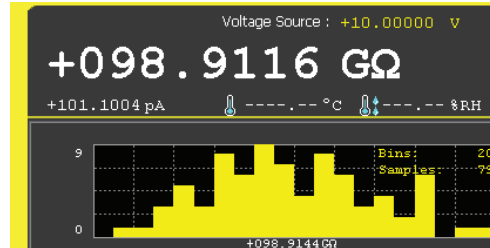

Pressing **View** → **Roll View** function key opens independent Roll View.

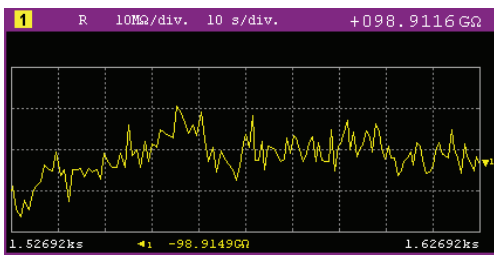

Pressing **View** → **Histogram View** function key opens independent Histogram View

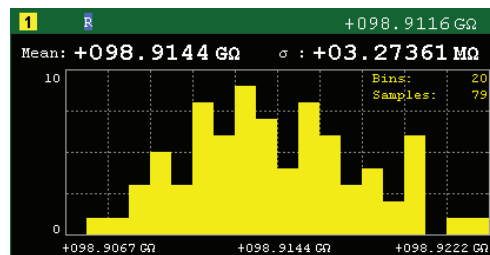

9. You can control the measurement speed and range easily using the Measurement navigation keys. The Null function allows you to set a reference point for other measurements. For example, you can use the null function to compare resistance variations among a group of resistors or to monitor the delta of a resistance change. The Filter function performs digital averaging on the measurement data, allowing you to achieve the desired integration and averaging times along with a stable reading.

Measurement navigation keys control test parameters

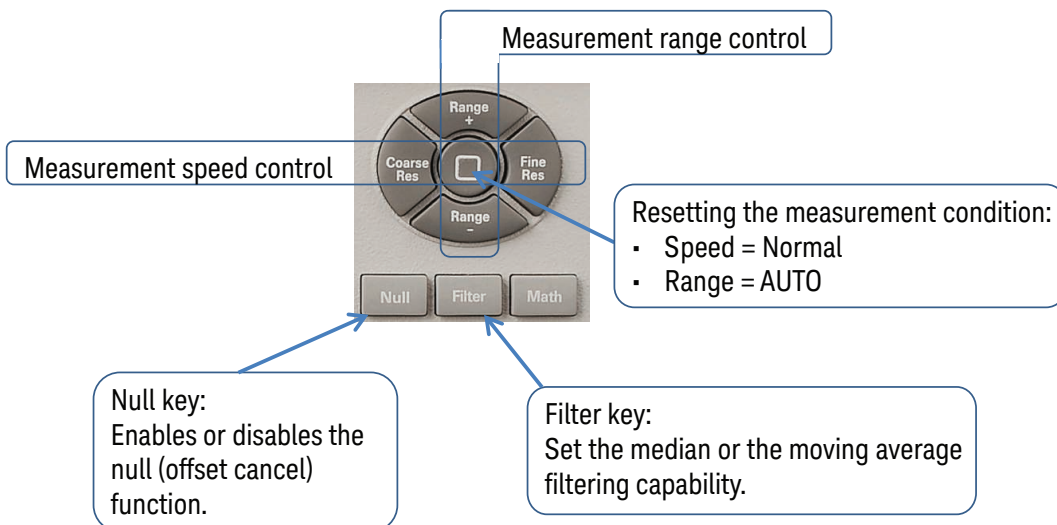

High Resistance Measurement Example *continued*

Measurement steps on B2985A/87A front panel operation



10. You can save the measurement configuration and the setup to internal memory or to an external USB device.

The following example shows how to save the setup to the internal memory.

1. Press the [Save] key. Save System popup “Select memory location to be saved.” shows up.
2. Choose and press one of the function key locations to save the current setup. You can recall the setup by pressing the [Recall] key and selecting the setup.

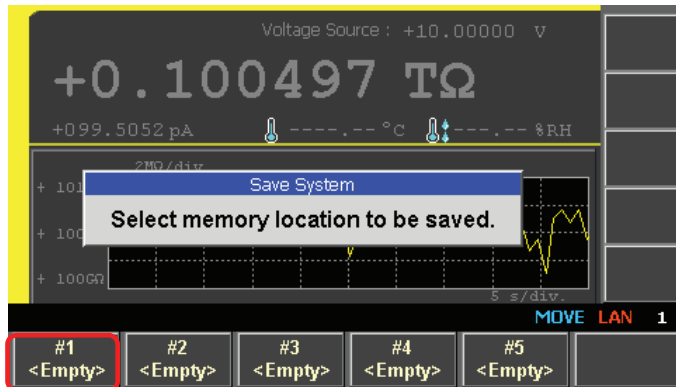
Press  key, and select one of the memory key to save the setup.



  **#1**
22:55:30 → The saved setup can be recalled by Pressing  key.

Example 2. Grounded resistance measurement

Figure 9 shows the configuration for a grounded measurement. The ammeter is connected on the voltage source in this configuration, and the internal switch connection between the Vs Low and the ammeter low (Common) must be open. The Vs Low and the Chassis ground are connected using a banana to lug cable shown in the diagram. The following steps explain how to configure a grounded measurement.

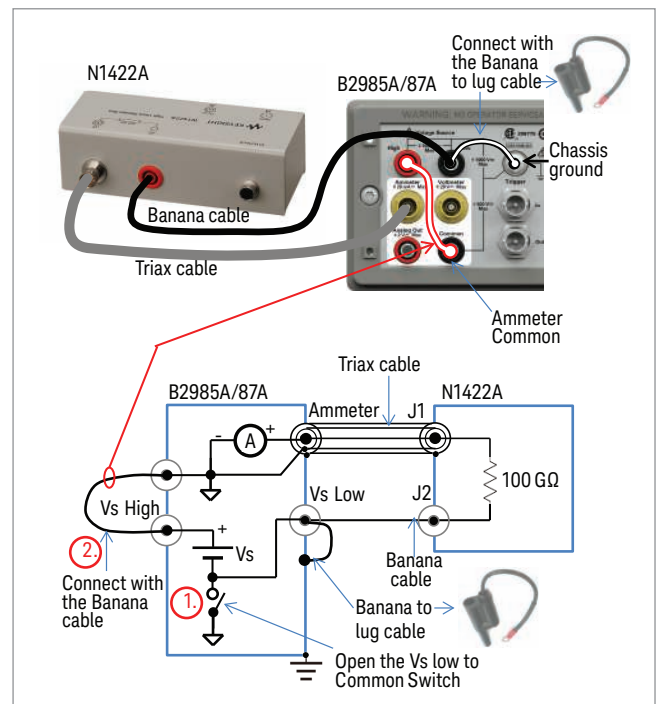
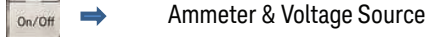

Figure 9. High-resistance measurement setup (Grounded).

High Resistance Measurement Example *continued*

To disconnect the Vs Low and the ammeter low. (Refer to Figure 9.)

Step 1. Press the [On/Off] key to turn off both the Ammeter input and the voltage source output.



Step 2. Press the [View] key repeatedly until the [System Menu] function key are shown in the function key.



Step 3. Press the [System Menu] key, then press the [Config] function key.



Step 4. Press [Source] key.



Step 5. Press [Connection ...] key.



Step 6. The Output Connection input panel is shown. (Refer to Figure 10 for steps 6 to 8.)

Rotate the knob and move the cursor onto the input field displaying “Low Terminal State”.

7. Press the rotary knob to change the input field to green EDIT mode.

Change the Low Terminal State to “Floating”.

8. Press [Apply], and then press OK.

The Vs low is then set to a floating state and is disconnected from the Ammeter common.

Step 6.

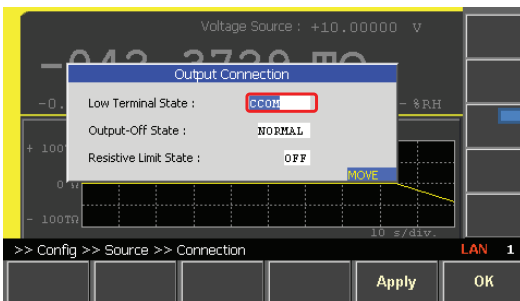

Step 7.

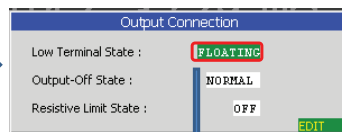

Step 8.



Indicates the Vs low is disconnected from the Ammeter common

Figure 10. Procedure to set Vs low to a floating state

High Resistance Measurement Example *continued*

9. To measure high resistance, repeat the steps outlined in example 1.

If you have already set up the instrument according to example 1, then set both the Ammeter and the Voltage Source to ON the state by pressing the [ON/Off] key, and pressing the [Run/Stop] key. Figure 11 shows example data for a grounded measurement. Note that the resistance is displayed as a negative value because the current flowing from the ammeter input is in the negative direction. This is an indication that the measurement is being made in the grounded mode.

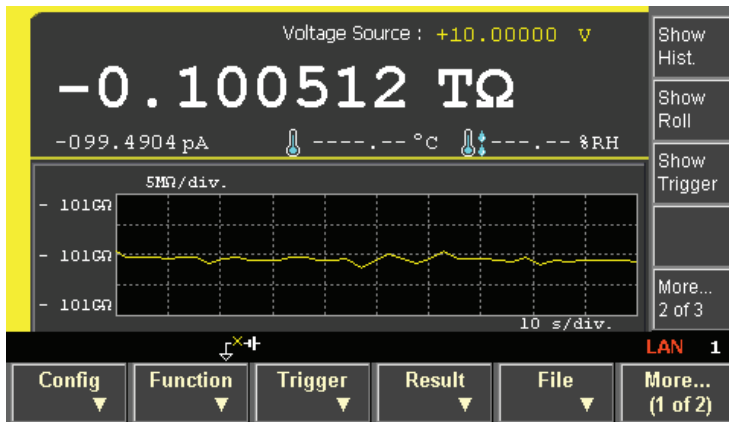

Figure 11. Grounded high resistance test example.

Conclusion

The Keysight B2985A/B2987A Electrometer/High Resistance Meter can measure high resistances up to 10 PΩ (10^{16}). It can do this for various devices, components and materials in both Grounded and Floating configurations and it has ammeter guarding capability. The Histogram and Roll View graphs, along with the time sampling X-Y Graph View, provide invaluable real-time visual information about the measurement being made.

The Null and Filter functions not only provide measurement convenience, but they also expand the number of high resistance measurement applications. In addition, the Measurement navigation feature greatly facilitates test execution. The Keysight B2985A/2987A Electrometer/High Resistance Meter transforms high resistance measurements from “difficult to setup and uncertain test results” to “easy to setup and confident test results”.

High Resistance Test Accessories

If you frequently switch between floating and the grounded high resistance measurements, the N1414A High Resistance Measurement Universal Adapter shown in Figure 12 is useful. The N1414A can switch between floating mode and grounded mode by a single button push, eliminating the configuration changes shown in Figure 9.

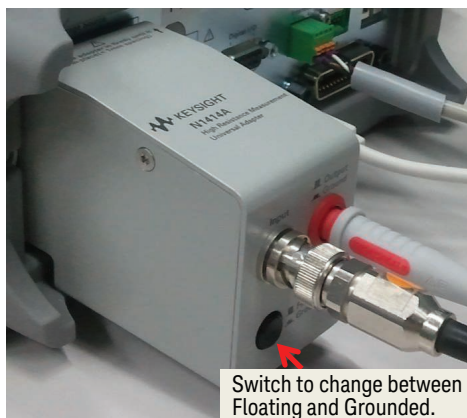

myKeysight

myKeysight

www.keysight.com/find/mykeysight

A personalized view into the information most relevant to you.



www.axiestandard.org

AdvancedTCA® Extensions for Instrumentation and Test (AXIe) is an open standard that extends the AdvancedTCA for general purpose and semiconductor test. Keysight is a founding member of the AXIe consortium. ATCA®, AdvancedTCA®, and the ATCA logo are registered US trademarks of the PCI Industrial Computer Manufacturers Group.



www.lxistandard.org

LAN eXtensions for Instruments puts the power of Ethernet and the Web inside your test systems. Keysight is a founding member of the LXI consortium.



www.pxisa.org

PCI eXtensions for Instrumentation (PXI) modular instrumentation delivers a rugged, PC-based high-performance measurement and automation system.



Three-Year Warranty

www.keysight.com/find/ThreeYearWarranty

Keysight's commitment to superior product quality and lower total cost of ownership. The only test and measurement company with three-year warranty standard on all instruments, worldwide.



Keysight Assurance Plans

www.keysight.com/find/AssurancePlans

Up to five years of protection and no budgetary surprises to ensure your instruments are operating to specification so you can rely on accurate measurements.



www.keysight.com/quality

Keysight Technologies, Inc.
DEKRA Certified ISO 9001:2008
Quality Management System

Keysight Channel Partners

www.keysight.com/find/channelpartners

Get the best of both worlds: Keysight's measurement expertise and product breadth, combined with channel partner convenience.

www.keysight.com/find/precisionMEASURE



Keysight B2900 Precision Instrument Family

The B2900Family lines up products for both precision source and precision measurement.

www.keysight.com/find/b2900a

For more information on Keysight Technologies' products, applications or services, please contact your local Keysight office. The complete list is available at: www.keysight.com/find/contactus

Americas

| | |
|---------------|------------------|
| Canada | (877) 894 4414 |
| Brazil | 55 11 3351 7010 |
| Mexico | 001 800 254 2440 |
| United States | (800) 829 4444 |

Asia Pacific

| | |
|--------------------|----------------|
| Australia | 1 800 629 485 |
| China | 800 810 0189 |
| Hong Kong | 800 938 693 |
| India | 1 800 112 929 |
| Japan | 0120 (421) 345 |
| Korea | 080 769 0800 |
| Malaysia | 1 800 888 848 |
| Singapore | 1 800 375 8100 |
| Taiwan | 0800 047 866 |
| Other AP Countries | (65) 6375 8100 |

Europe & Middle East

| | |
|----------------|---------------|
| Austria | 0800 001122 |
| Belgium | 0800 58580 |
| Finland | 0800 523252 |
| France | 0805 980333 |
| Germany | 0800 6270999 |
| Ireland | 1800 832700 |
| Israel | 1 809 343051 |
| Italy | 800 599100 |
| Luxembourg | +32 800 58580 |
| Netherlands | 0800 0233200 |
| Russia | 8800 5009286 |
| Spain | 0800 000154 |
| Sweden | 0200 882255 |
| Switzerland | 0800 805353 |
| | Opt. 1 (DE) |
| | Opt. 2 (FR) |
| | Opt. 3 (IT) |
| United Kingdom | 0800 0260637 |

For other unlisted countries:
www.keysight.com/find/contactus
(BP-07-10-14)

