

Keysight Technologies 8500 FE-SEM System

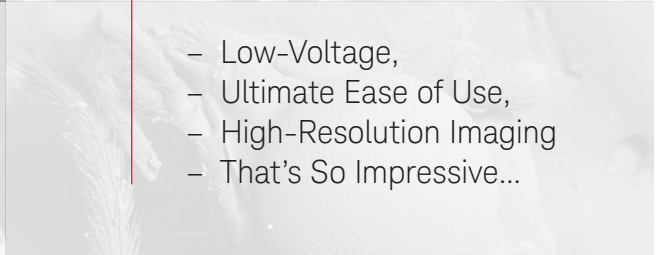
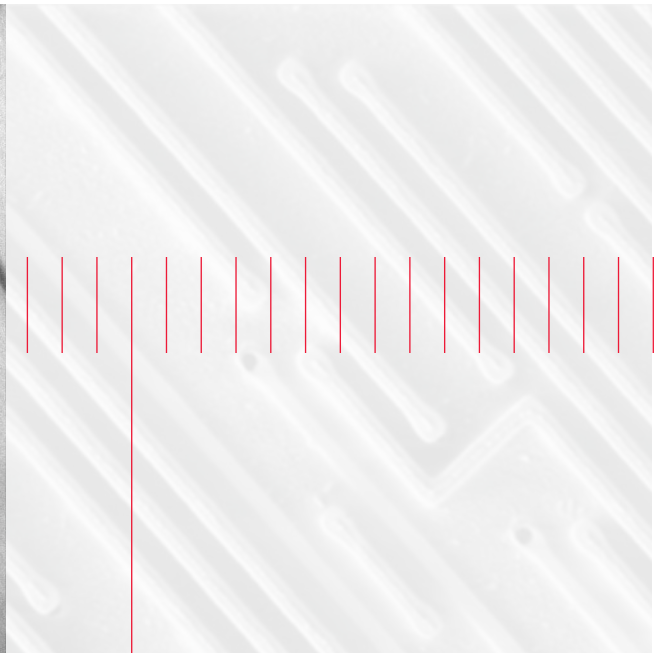
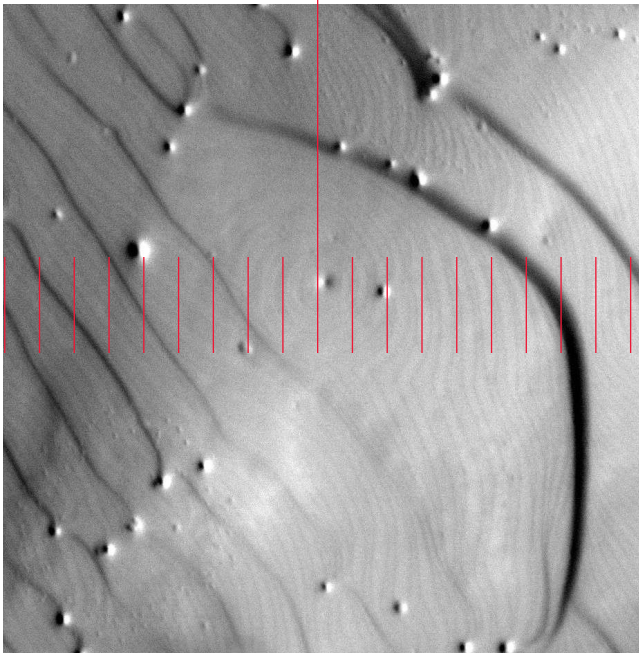

- Low-Voltage,
- Ultimate Ease of Use,
- High-Resolution Imaging
- That's So Impressive...

The Advent of the Keysight 8500

Keysight Technologies, Inc. innovative 8500 system is the world's first compact field-emission scanning electron microscope (FE-SEM) designed specifically to allow you to perform low-voltage, high-resolution imaging in your own lab!

The extraordinary Keysight 8500 FE-SEM achieves the extremely high surface contrast and resolution typically found only in much larger and more expensive field emission microscopes. This scientific-grade system, which offers several imaging techniques for enhancing surface contrast, is able to resolve details for samples up to 100 x 60mm on a variety of nanostructured materials, including polymers, thin films, biomaterials, and other energy-sensitive samples – on any substrate, even glass.

No dedicated facilities are required, just an AC power outlet! About the size of an average laser printer, the easy-to-install Keysight 8500 FE-SEM provides true plug-and-play convenience. For ultimate ease of use, a programmable X-Y-Z stage allows you to set precise coordinates, scan, and save locations.

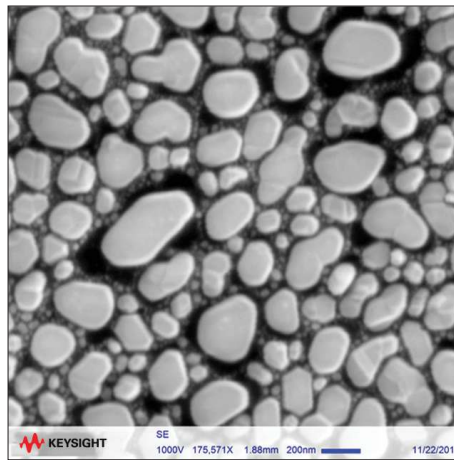

Au on C Calibration Sample showing 10nm Au Islands and 7nm Gaps.

The Low-Voltage Advantage

Traditional SEMs operate at beam voltages that present many issues when used to image certain types of materials, including both nonconductive organic samples (e.g., polymers, enzymes, cells, membranes) and nonconductive inorganic samples (e.g., ceramics, pigments, minerals, composites).

Uncoated nonconductive samples are challenging in a traditional SEM due to charge buildup that distorts the images – or prevents any imaging at all. Soft samples can be damaged or destroyed as a result of the high energy dose. Typically, the solution is to coat these nonconductive specimens with a thin conductive layer (carbon, gold or others), but this coating often masks the nanoscale features that are of interest.

In low voltage imaging, the beam/specimen interaction volume is significantly smaller than that in high voltage imaging. Thus low voltage microscopy is truly a surface imaging technique which is able to reveal the true surface morphology. Another advantage of low voltage microscopy is that it can eliminate the need to coat insulating samples. Because of the high secondary electron yield at low voltages, a neutral status can be achieved on the specimen surface for a stable imaging. Additionally, electron beam damage can be reduced or localized in low voltage microscopy.

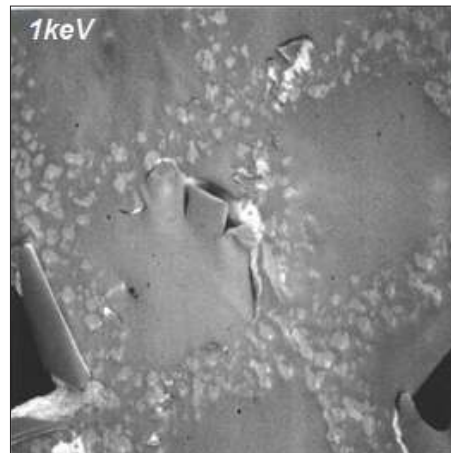
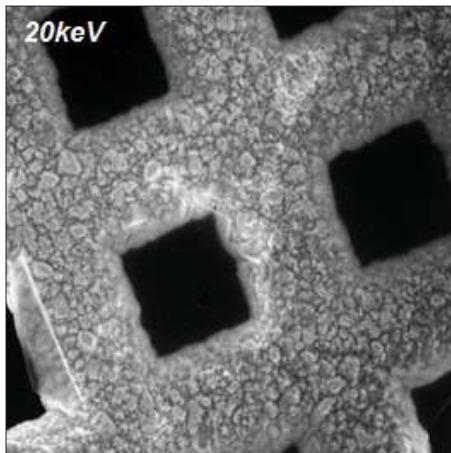
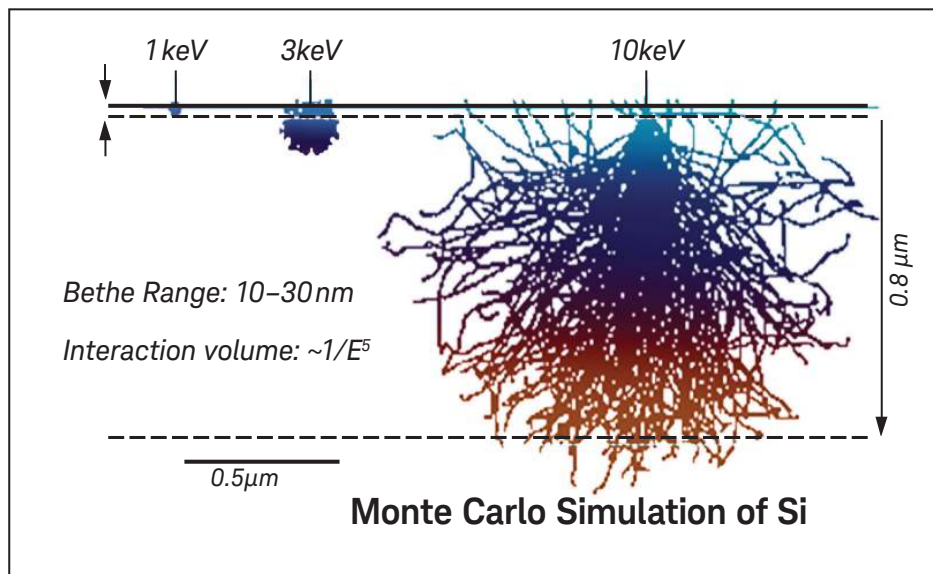

Images of carbon thin film on copper grid recorded with 20 keV and 1 keV electron beams (D. C. Joy and C. S. Joy, *Micron* 27, 247, 1996).

Technology Optimized for Your Lab

The remarkably compact Keysight 8500 FE-SEM utilizes a unique micro-machined miniature electron beam column with all-electrostatic lens to deliver unprecedented performance. The 8500 system's thermal field emission electron source provides high brightness, high stability, small virtual source size, and low energy spread. Its unique beam design is capable of achieving sub-10nm resolution at 1kV. The innovative all-electrostatic lens design eliminates any hysteresis effect and ensures repeatable performance without constant re-tuning. In addition the system's imaging voltage is continuously variable from 500V to 2kV.

Surface morphologies are revealed using the 8500 FE-SEM system's multiple imaging modes, which include secondary electron imaging, backscattered electron imaging, and topographic imaging. A four-segment microchannel plate (MCP) detector that provides topographic imaging along two orthogonal directions further enhances the surface detail.

The versatile imaging system eliminates the concerns of charging on nonconductive samples as well as the necessity to coat such samples. It also eliminates the need to resort to increased-pressure operation (i.e., the use of so-called "variable pressure" modes), which degrades resolution and prevents secondary electron imaging modes.

"The 8500 SEM requires minimal sample preparation, is easy to use and provides nano-scale resolution images for a wide range of samples, especially biological materials. Its computer interface is intuitive making it very easy to train students to use the SEM and obtain high quality images. Sample loading is also very quick and easy and the generous sample chamber accommodates a wide variety of sample shapes and sizes."

Dr. Prashant Sharma Associate Professor and Chair Department of Physics Suffolk University Boston, MA

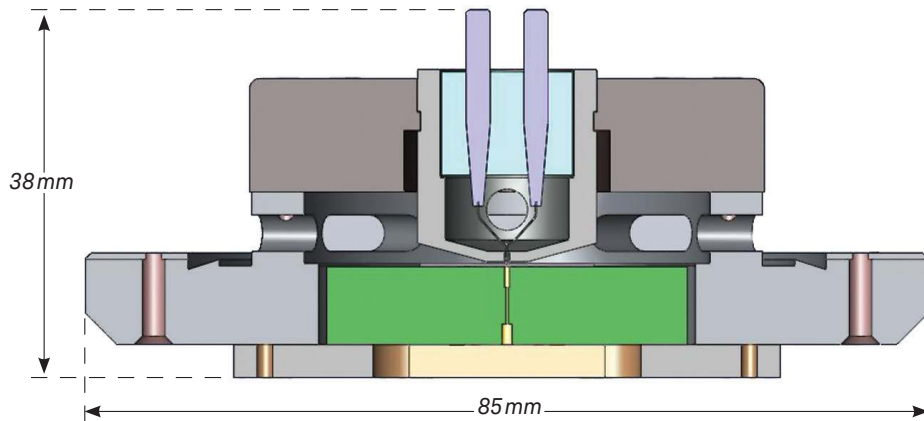

Cross-section illustration of the assembly column for the 8500 FE-SEM.

Limitless Applications!

The innovative, award-winning* technology utilized by the low-voltage **Keysight 8500 FE-SEM** excels at the formation of high-resolution, high-contrast images of surfaces in structures where the volumes of interest approach nanometer dimensions. The surface specificity of low-voltage scanning electron microscopy coupled with the high resolution and brightness of a field-emission electron source offer a radically different view of sample surface detail on a broad range of differing materials.

Polymers

The low-voltage Keysight 8500 FE-SEM provides a straightforward technique for high-resolution imaging of polymers, typically without the need for a metal coating. Although the application range of polymers spans many levels of sophistication in materials and processing, the morphological features of interest can easily be investigated with the 8500 system.

Examples include non-woven fabrics (e.g., facemasks for particle filtration), barrier films (e.g., Li-ion battery separator membranes), and polymer beads (e.g., printer toners).

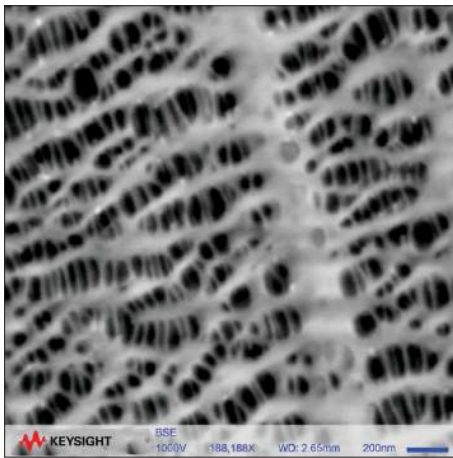

Uncoated Celgard 2325 Lithium ion battery separator membrane.

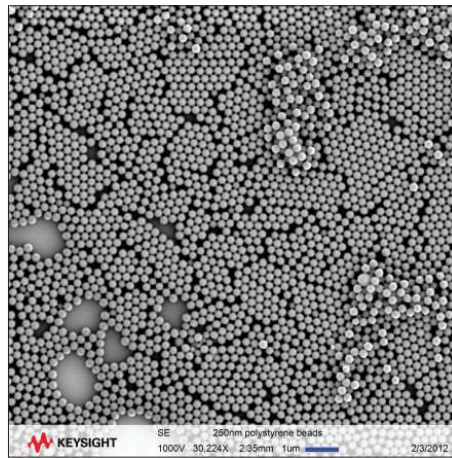

Uncoated 250nm polystyrene beads on Si. (Courtesy of Fudan University.)

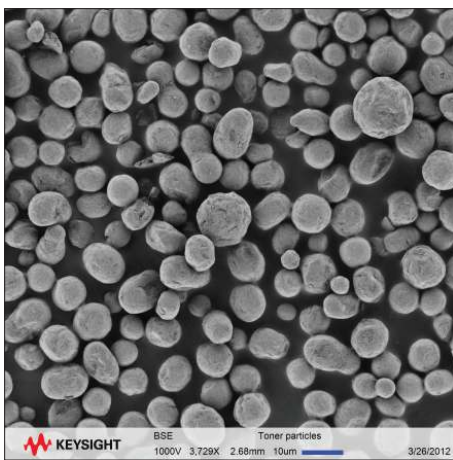

Uncoated toner particles (carbon/polymer blend).

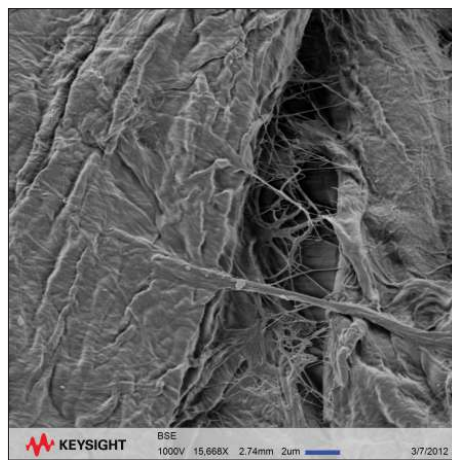

Uncoated non-woven fabrics on a facemask for particle filtration.

Biological/Organic Samples

Using the low-voltage Keysight 8500 FE-SEM, it is possible to image fixed biological samples with high resolution and excellent contrast, typically without the need for a metal coating and without incurring beam damage to the samples. Despite the fact that biological samples encompass a vast range of size scales, composition, and structures, the morphological features of interest can easily be explored with the 8500 system.

Examples include heart muscle tissue, engineered cell substrates (PDMS pillars), parasites, collagen, marine plankton and insects.

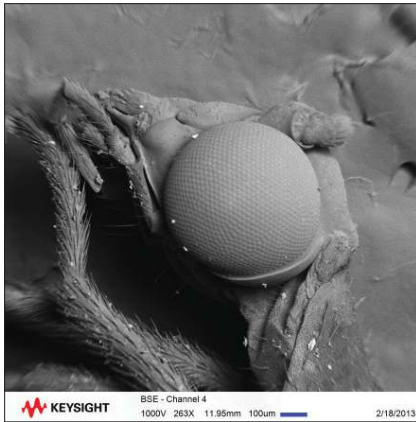

Uncoated Insect head.

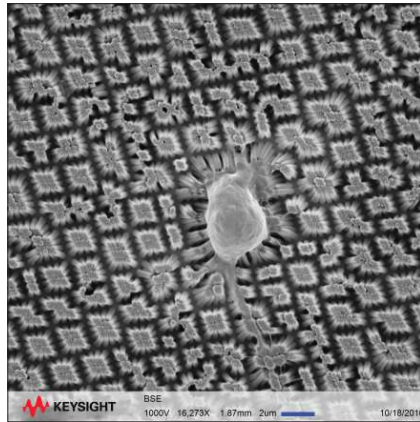

Uncoated cell growth on PDMS nanopillars. (Courtesy of Columbia University.)

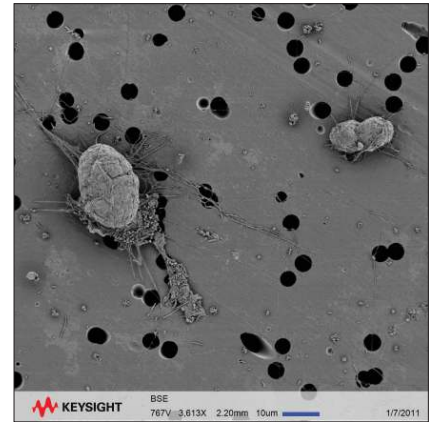

Uncoated gymnodinoid dinoflagellate collected on polycarbonate membrane. (Courtesy of Temple University.)

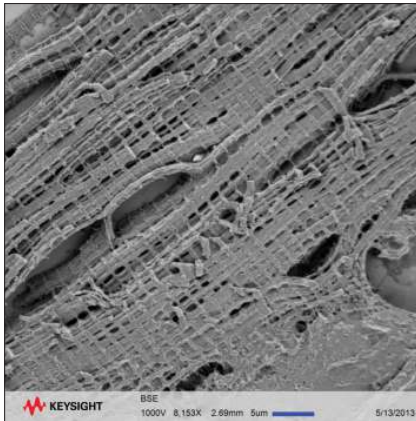

Uncoated heart muscle tissue. (Courtesy of Sandra Mayr, Linz University, Austria.)

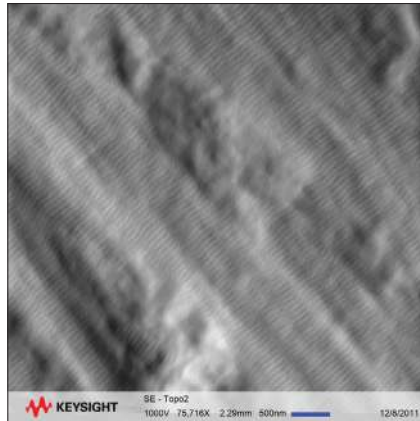

Topo image of collagen. (Courtesy of University of Michigan.)

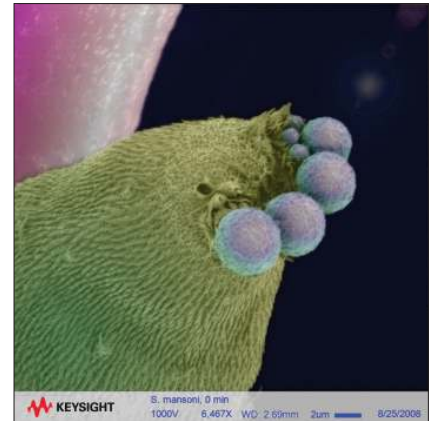

Colored image of uncoated S. Mansoni parasite.

Graphene Films/Carbon Nanotubes

The Keysight 8500 FE-SEM meets all the requirements needed to investigate graphene: high spatial resolution, low beam energy, high-contrast imaging, and a high-performance detector. Images acquired with the 8500 system reveal nano-sized surface details on graphene films with enhanced contrast.

The 8500 offers a fast, non-invasive, and effective approach for graphene multilayer domain identification and film defect detection. Additionally, it enables high-resolution imaging of carbon nanotubes and carbon nanotube composites, typically without the need for a metal coating.

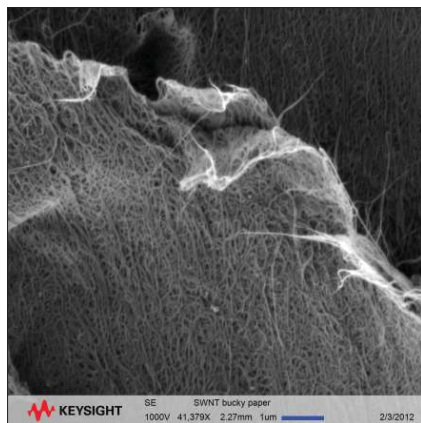

The cutting edge of a SWNT bucky paper.



The CNT/chitosan nanocomposite. (Courtesy of University of Hawaii.)

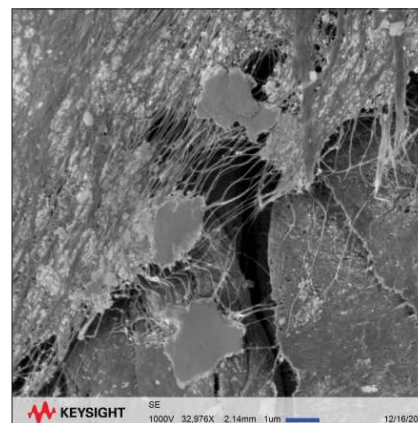

MWNTs/metal nanocomposite. (Courtesy of Rochester Institute of Technology.)

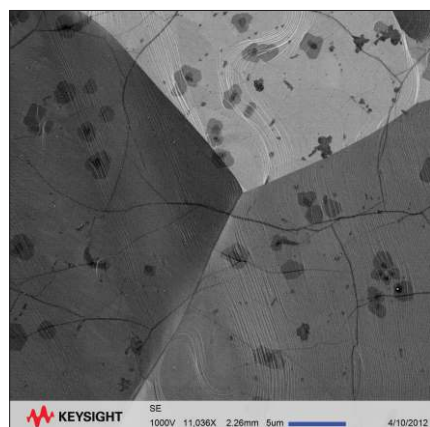

As-grown CVD graphene on copper foil. (Courtesy of Temple University.)

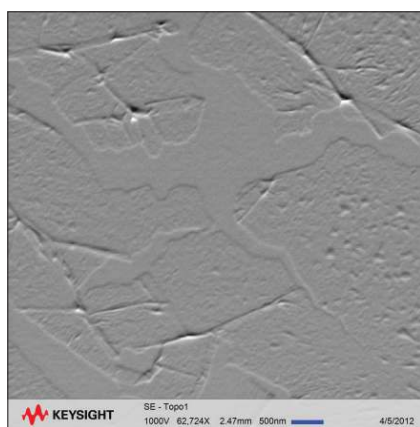

Topo image of transferred single layer graphene on Si. (Courtesy of Temple University.)

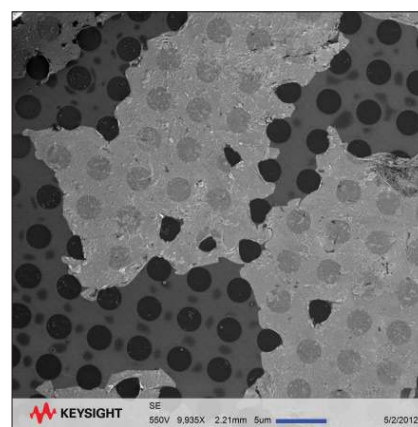

Graphene on grid with pores. (Courtesy of Temple University.)

Micro and Nano Materials

The Keysight 8500 FE SEM provides a unique perspective in imaging the emerging class of nano materials. Whether it is nano particles used for reinforcing or altering the properties of common thermoset plastics in the automotive sector, or the inclusion of silver nanoparticles as an embedded antibiotic agent, the 8500 provides outstanding resolution and contrast for characterizing the material properties.

Operating at low beam voltages, you get outstanding resolution, and detail of nanoparticles without the need to coat with a conductive material. The 8500 yields an incredible amount of fine surface detail that can provide fresh insights to the dynamics and interactions that are facilitated by nano particles. With applications in medicine, life science, manufacturing and material science, environmental abatement, and energy production and storage, nanoparticles are increasingly essential to the performance of products today, and driving research for the products of tomorrow.

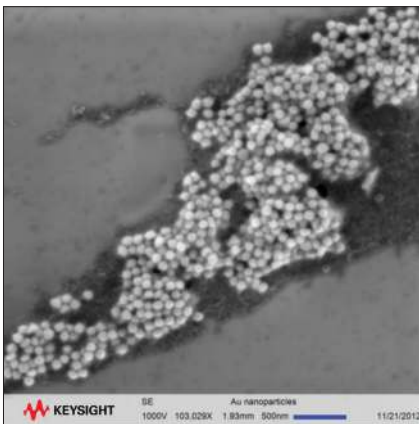

70-80nm Au nanoparticles. (Courtesy of Massachusetts Institute of Technology.)

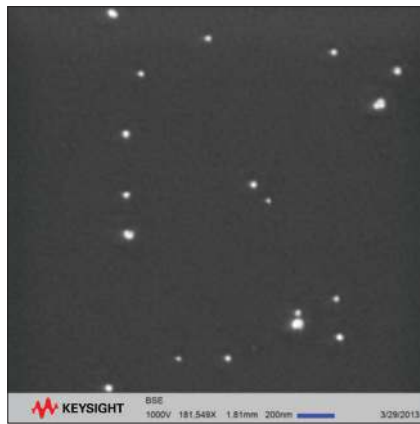

10-20nm Ag nanocrystals on silica thin film. (Courtesy of US Food and Drug Administration.)

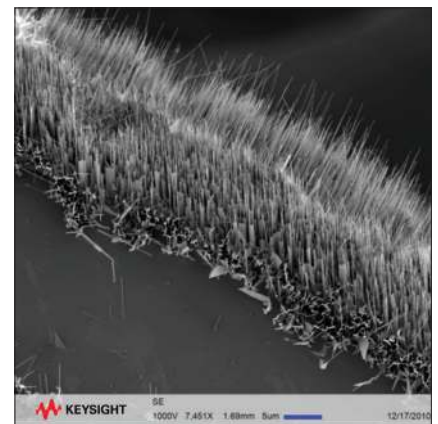

Aligned ZnO nanowires. (Courtesy of US Naval Research Laboratory.)

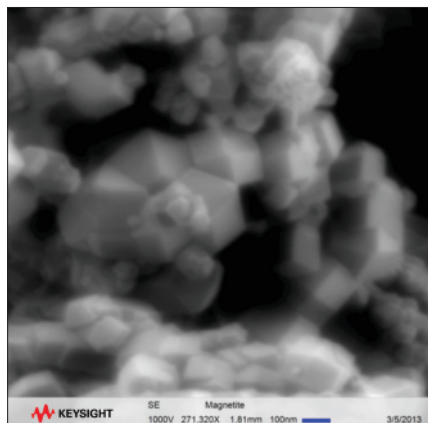

Uncoated magnetite (Fe₃O₄) nanocrystals. (Courtesy of University of Arkansas.)

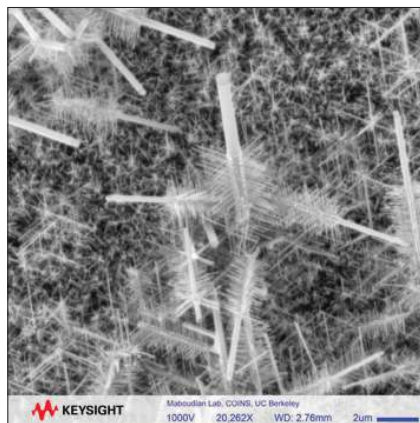

Branched Si nanowires. (Courtesy of University of California, Berkeley.)

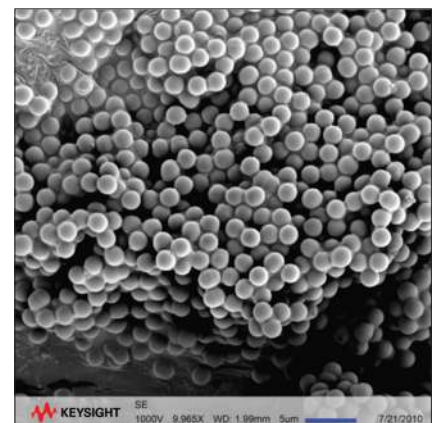

Uncoated silica microspheres.

Thin Lines and Semiconductor Devices

The compact, low-voltage 8500 FE-SEM provides an easy-to-use solution for high-resolution imaging of semiconductor device structures, typically without the need for a metal coating to dissipate charge buildup. Semiconductor samples span many levels of sophistication in materials, design, and processing, but their morphological features of interest and defects can easily be investigated with the 8500 system.

Examples include high-resolution imaging of single crystal SiC wafer, thin films, MEMS devices, gratings, AFM cantilevers, and chip metal conductor lines.

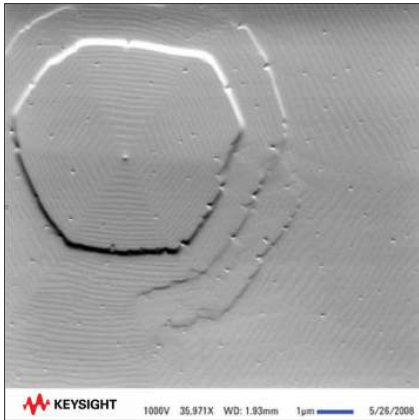

Topo image of a single crystal 6H-SiC wafer. (Courtesy of University of California, Berkeley).



Bilayer thin film coating on Si. (Courtesy of Boise State University).

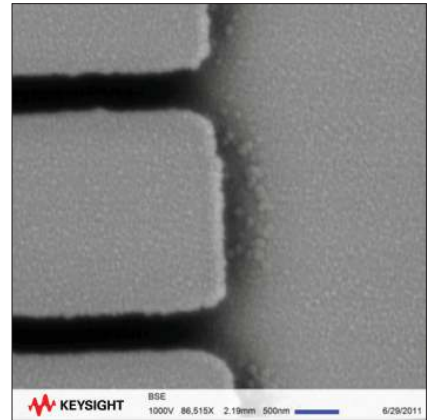

Microstructured grating (courtesy of University of Minnesota).



Tilted view of a MEMS device.

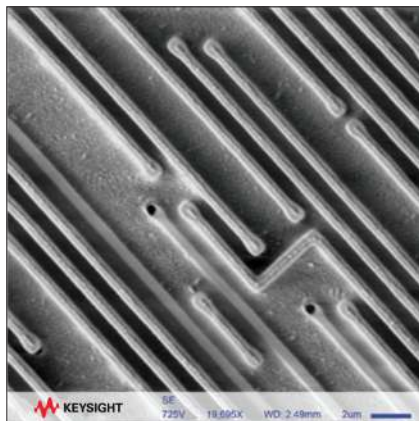

Deprocessed chip metal conductor lines.

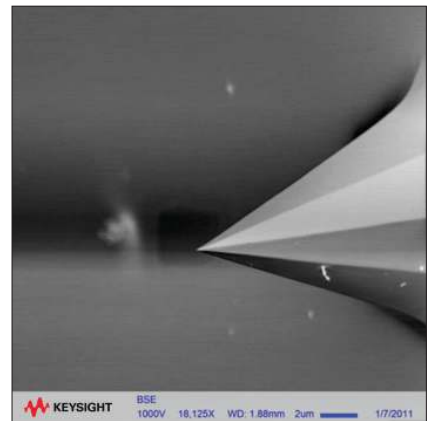

Metallized tip for AFM electrical measurements.

Other Applications

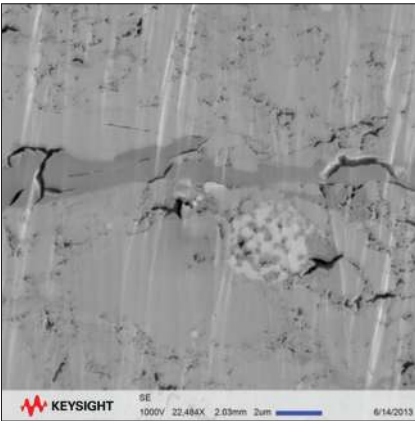

Ion polished oil shale sample.

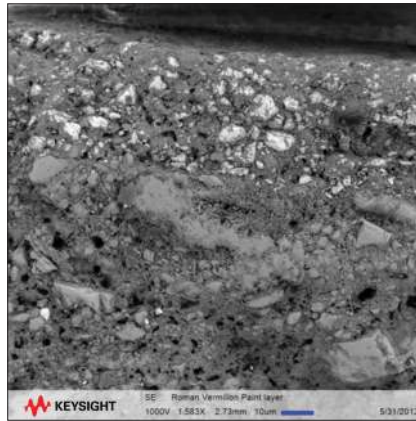

A petrographic thin section of a Roman wall painting fragment.

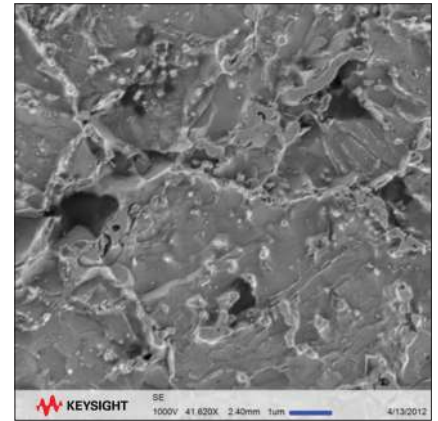

Surface of a polished metallographic specimen.

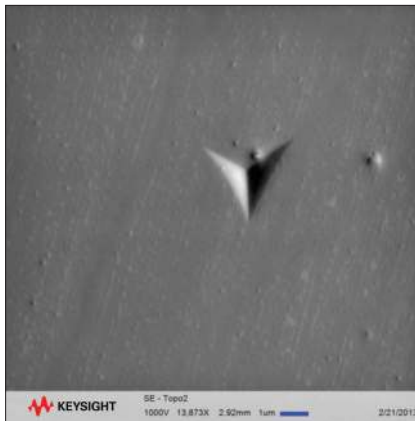

Topo image of a nanoindent on a specimen.

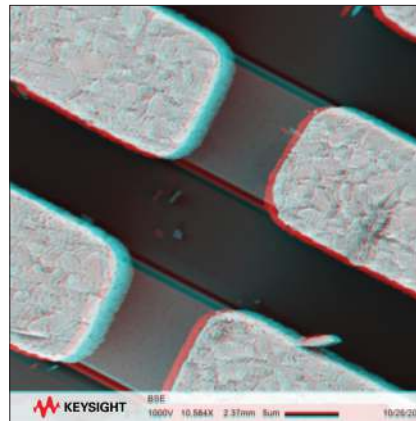

A stereo image of resistors on Si.

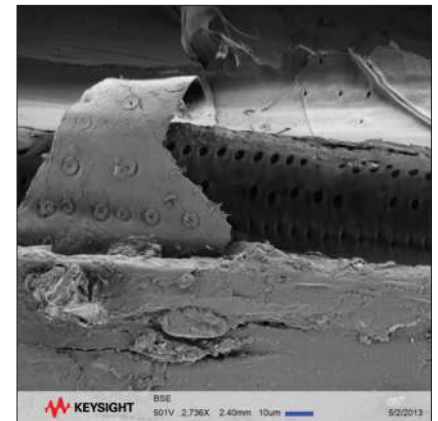

A loose vessel cell-wall of an uncoated beech sample.
(Courtesy of Institute for Building Materials, Concrete Construction and Fire Protection, Braunschweig, Germany.)

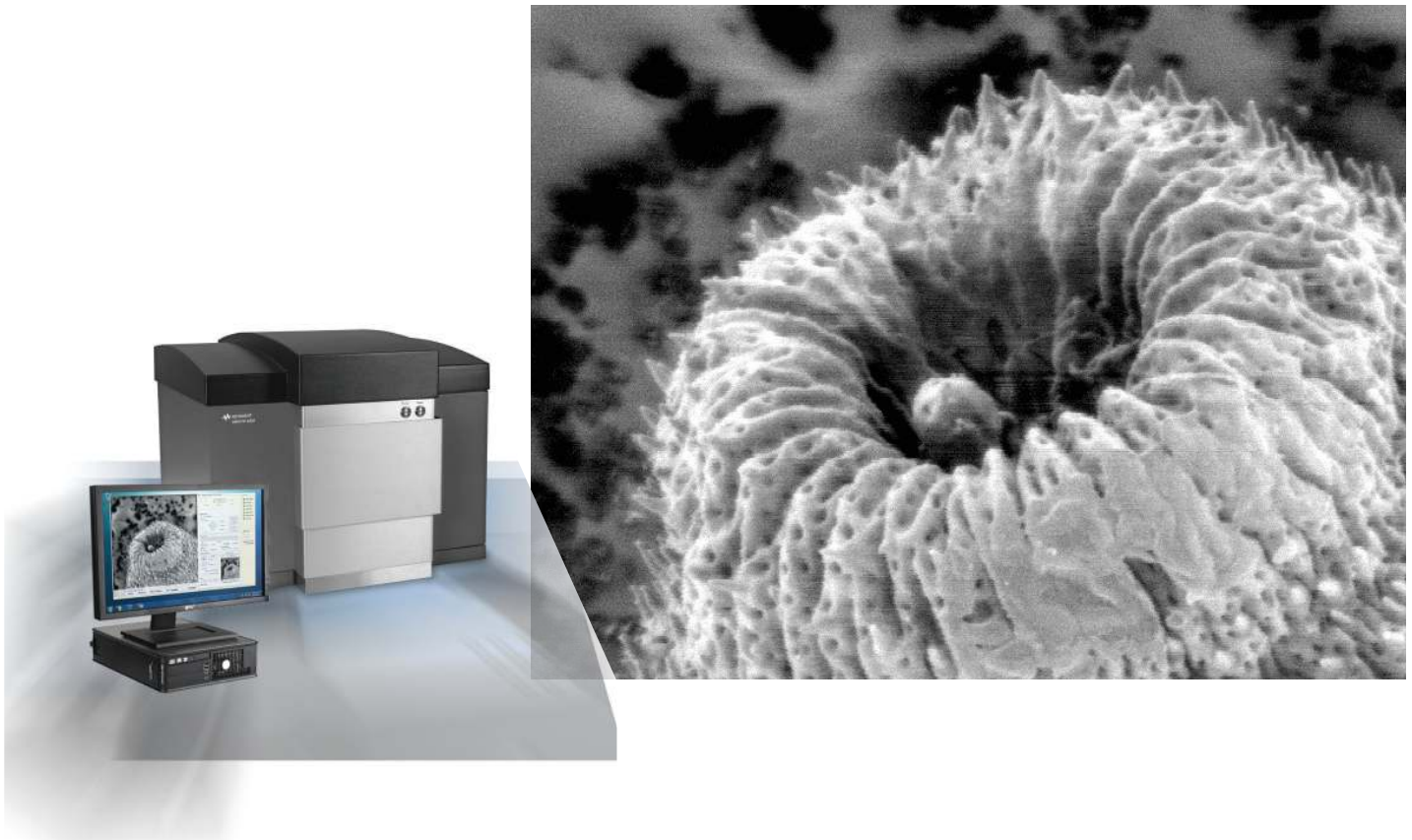

Compact System, Big Performance!

Leave behind any preconceived notions linking SEM performance to system size or complexity. The versatile Keysight 8500 FE-SEM is ready to bring high-resolution, low-voltage imaging to your lab in a convenient, easy-to-use, and non-resource-intensive package. It truly is in a class of its own.

Regardless of your application requirements, the 8500 will deliver outstanding performance and imaging without complex sample preparation or the need to coat specimens. Its tremendous breadth of application utility, coupled with the simplicity of obtaining spectacular, publication-worthy data, makes the 8500 system unlike any SEM you have seen. Request a demo today and imagine the incredible!

You Have To See It!

For more information about the revolutionary 8500 FE-SEM, or to make arrangements for one of our application scientists to image a sample of yours on this amazing system, please contact Keysight Technologies.

We look forward to helping you get the resolution you need!

Nanomeasurement Systems from Keysight Technologies

Keysight offers high-precision, modular nanomeasurement solutions for research, industry, and education. Exceptional worldwide support is provided by experienced application scientists and technical service personnel. Keysight's leading-edge R&D laboratories are dedicated to the timely introduction and optimization of innovative and easy-to-use nanomeasurement technologies.

www.keysight.com/find/nano

For more information on Keysight Technologies' products, applications or services, please contact your local Keysight office. The complete list is available at: www.keysight.com/find/contactus

www.keysight.com/find/fe-sem

Americas

Canada	(877) 894 4414
Brazil	55 11 3351 7010
Mexico	001 800 254 2440
United States	(800) 829 4444

Asia Pacific

Australia	1 800 629 485
China	800 810 0189
Hong Kong	800 938 693
India	1 800 112 929
Japan	0120 (421) 345
Korea	080 769 0800
Malaysia	1 800 888 848
Singapore	1 800 375 8100
Taiwan	0800 047 866
Other AP Countries	(65) 6375 8100

Europe & Middle East

Austria	0800 001122
Belgium	0800 58580
Finland	0800 523252
France	0805 980333
Germany	0800 6270999
Ireland	1800 832700
Israel	1 809 343051
Italy	800 599100
Luxembourg	+32 800 58580
Netherlands	0800 0233200
Russia	8800 5009286
Spain	800 000154
Sweden	0200 882255
Switzerland	0800 805353
	Opt. 1 (DE)
	Opt. 2 (FR)
	Opt. 3 (IT)
United Kingdom	0800 0260637

For other unlisted countries:
www.keysight.com/find/contactus
 (BP-09-23-14)