

Agilent B1540A EasyEXPERT Software

Self-paced Training Manual



Agilent Technologies

Notices

© Agilent Technologies, Inc. 2009, 2012

No part of this manual may be reproduced in any form or by any means (including electronic storage and retrieval or translation into a foreign language) without prior agreement and written consent from Agilent Technologies, Inc. as governed by United States and international copyright laws.

Manual Part Number

B1540-90040

Edition

Edition 1, November 2009

Edition 2, November 2012

Agilent Technologies
5301 Stevens Creek Blvd
Santa Clara, CA 95051 USA

Warranty

The material contained in this document is provided “as is,” and is subject to being changed, without notice, in future editions. Further, to the maximum extent permitted by applicable law, Agilent disclaims all warranties, either express or implied, with regard to this manual and any information contained herein, including but not limited to the implied warranties of merchantability and fitness for a particular purpose. Agilent shall not be liable for errors or for incidental or consequential damages in connection with the furnishing, use, or performance of this document or of any information contained herein. Should Agilent and the user have a separate written agreement with warranty terms covering the material in this document that conflict with these terms, the warranty terms in the separate agreement shall control.

Technology Licenses

The hardware and/or software described in this document are furnished under a license and may be used or copied only in accordance with the terms of such license.

Restricted Rights Legend

If software is for use in the performance of a U.S. Government prime contract or subcontract, Software is delivered and licensed as “Commercial computer software” as defined in DFAR 252.227-7014 (June 1995), or as a “commercial item” as defined in FAR 2.101(a) or as “Restricted computer software” as defined in FAR

52.227-19 (June 1987) or any equivalent agency regulation or contract clause. Use, duplication or disclosure of Software is subject to Agilent Technologies’ standard commercial license terms, and non-DOD Departments and Agencies of the U.S. Government will receive no greater than Restricted Rights as defined in FAR 52.227-19(c)(1-2) (June 1987). U.S. Government users will receive no greater than Limited Rights as defined in FAR 52.227-14 (June 1987) or DFAR 252.227-7015 (b)(2) (November 1995), as applicable in any technical data.

In This Manual

This document is the self-paced training manual to help you to understand how to use the Agilent EasyEXPERT software.

- **Module 1. Getting Started**

This module explains the basic operations of the EasyEXPERT. You will learn how to perform application test, quick test, and tracer test.
- **Module 2. Data Display and Management**

This module explains the data display and analysis capabilities of the EasyEXPERT software. You will learn how to use analysis tools, how to change display setup, and how to print/export test result data.
- **Module 3. Classic Test Environment**

This module explains the classic test mode of the EasyEXPERT. You will learn how to create the classic test setup in the course exercises.
- **Module 4. Measurement Functions**

This module explains the measurement functions available with the EasyEXPERT. You will learn how to use various measurement functions in the course exercises.
- **Module 5. Modifying Application Test Definitions**

This module explains a modification example of an application test definition. You will learn how to modify the definition in a course exercise.
- **Module 6. Creating Your Test Definitions**

This module explains about the application test definition. You will learn how to create your application test definition in a course exercise.
- **Module 7. Advanced Definitions and Operations**

This module explains how to control external GPIB devices, how to call an execution file, how to perform a repeat measurement, and how to use the prober control script.
- **Module 8. Miscellaneous Operations**

This module explains what is the status indicator, what is the automatic data export function and the automatic data record function, how to perform selftest and calibration, how to perform SMU zero offset cancel, and such.

Class Exercises

Class exercises use the test setup listed below. The test setup data are only examples and included in the Demo.xpg file stored in *Agilent B1500 Series Manual CD*.

Module	Exercise	Device	Test setup/definition/data	Page
Module 1	Id-Vd measurement	MOSFET	Id-Vd	1-19
	Id-Vg, gm-Vg measurement	MOSFET	Vth gmMax	1-27
	Id-Vd measurement	MOSFET	Trace IdVd	1-31
	B2200/E5250 switch control	-	-	1-54
Module 2	Id-Vg, gm-Vg measurement	MOSFET	GMMAX	2-30
	Using Preview window	-	-	2-33
Module 3	Id-Vd measurement	MOSFET	Trng Id-Vd	3-27
	Multi Channel I/V Sweep Measurement	Bipolar Tr LED	Trng Multi	3-39
	I/V List Sweep Measurement	MOSFET	Trng List	3-51
	I/V-t sampling measurement	0.1 μ F	Trng Sampling	3-65
	C-V sweep measurement	MOSFET	Trng CV	3-79
	B2200/E5250 switch control	-	Trng Switch	3-84
	Direct Control (C-f measurement)	0.1 μ F	Trng C-f	3-91
Module 4	SMU pulse mode	MOSFET	IDVD-Pulse	4-7
	RC measurement	0.1 μ F and 511 kohm	RC-sampling-log	4-15
	Negative hold time	511 kohm	R-sampl-neg-hold	4-21
	Auto analysis	MOSFET	GMMAX	4-27
	Bias hold function	LED	LED	4-38
Module 5	Modifying application test definition	MOSFET	Trng IdVd Vth	5-14
			Trng idvd idvg2	5-29
			Trng idvd idvg3	5-32
	Using auto analysys twice	MOSFET	Vth gmMax and Id	5-34
	Using vector data	MOSFET	Trng Cgg-Vg	5-42

Module	Exercise	Device	Test setup/definition/data	Page
Module 6	Creating application test definition	MOSFET	Trng idvd idvg	6-17
Module 7	no exercise			
Module 8	no exercise			

NOTE
Demo.xpg file

Demo.xpg file is required to create the Demo preset group which contains the test setup data used by the class exercises. And it is stored in the \data folder on *Agilent B1500 Series Manual CD*.

The Demo preset group should be created before starting the class exercise. To create the preset group, launch EasyEXPERT and import the file by using the Preset Group Import dialog box opened by clicking My Favorite Setup > Preset Group > Import Preset Group. The test setup data are only examples for the class exercises.

Before importing the Demo.xpg file, import the .xtd files stored in the same folder.

NOTE
.xtd files

The \data folder stores some .xtd files. They are the application test definitions used by some class exercises. To use the definition file, import the file by using the Test Definition Import dialog box opened by clicking Library > Import Test Definition. The test definition data are only examples for the class exercises.

NOTE
.xtr files

The \data folder also stores some .xtr files. They are the sample test results created by executing the test setup which has the same name as the result data. To display these sample test results, import the files by using the Test Result Import dialog box opened by clicking Results > Transport Data > Import.

NOTE
About sample data

The test setup data described in this manual are only examples. If these example data damage your devices, Agilent is *NOT LIABLE* for the damage.

Required Devices for Class Exercises

To perform the class exercises, you need the device set (Agilent part number 04156-87001) which contains the following devices.

Description	Quantity
N-channel MOSFET	2 ea.
NPN Bipolar Transistor	1 ea.
Red Miniature LED	1 ea.
0.1 μ F Capacitor 50 V	1 ea.
1.0 Ω Resistor 1/8 W	1 ea.
1.1 k Ω Resistor 1/8 W	1 ea.
511 k Ω Resistor 1/8 W	1 ea.

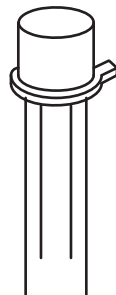

N-ch MOSFET



NPN bipolar Transistor



LED

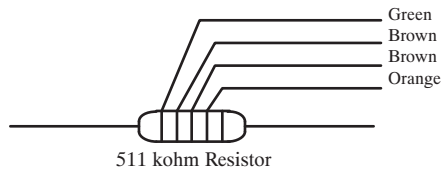
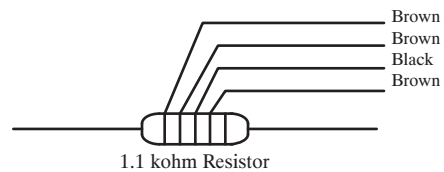
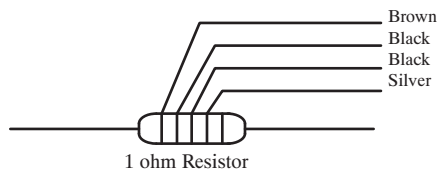

Required Accessories for Class Exercises

To perform the class exercises, you need the following accessories. Prepare the accessories shown below.

Designation	Description	Model No.	Qty.
1	Test Fixture	^a 16442A or 16442B (B1500A-A5F)	1 ea.
	28 pin socket module		1 ea.
	Connection wire		6 ea.
2	Triaxial Cable	16494A	4 ea.
3	Interlock Cable	16493J	1 ea.

- a. The 16058A Test Fixture for the 4145A/B may be substituted for the 16442A/B Test Fixture. If you use the 16058A, you also need the 16435A Interlock Adapter.

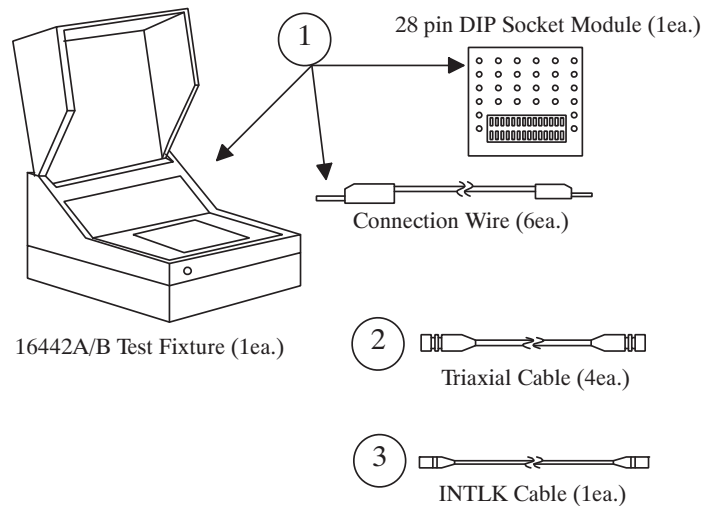

Module 1. Getting Started

- **To Launch EasyEXPERT**
- **To Specify/Create Workspace**
- **To Perform Application Test**
- **To Save/Recall Your Test Setup**
- **To Export/Import Your Preset Group**
- **To Export/Import Test Record**
- **To Perform Quick Test**
- **To Perform Tracer Test**
- **To Control Switching Matrix**
- **To Manage Data Display Window**

Module 2. Data Display and Management

- **Data Display window**
- **Graph Analysis Tools**
- **Data Status**
- **To Change Graph/List/Display Setup**
- **To See Print Preview**
- **To Print Display Data**
- **To Copy Graph Plot/List Data**
- **To Save Analysis Result**
- **To Use Preview Window**

Module 3. Classic Test Environment

- **Classic Test Execution Mode**
- **I/V Sweep Measurement**
- **Multi Channel I/V Sweep Measurement**
- **I/V List Sweep Measurement**
- **I/V-t Sampling Measurement**
- **C-V Sweep Measurement**
- **Switching Matrix Control**
- **Direct Control**

Module 4. Measurement Functions

- **SMU Pulsed Sweep Measurement**
- **I/V-t Sampling Measurement**
- **Negative Hold Time for High Speed Sampling**
- **Auto Analysis**
- **SMU Filter**
- **Standby Function**
- **Bias Hold Function**

Module 5. Modifying Application Test Definitions

- **To Open Application Test Definition**
- **To Modify Test Definition**
- **To Use Debug Tools**
- **To Use Built-in Functions**
- **To Add Data Display**
- **To Use Auto Analysis**
- **To Use Test Setup Internal Variables**
- **To Use Auto Analysis twice (as Class Exercise)**
- **To Use Vector Data (as Class Exercise)**

Module 6. Creating Your Test Definitions

- **What is Test Definition**
- **What is Test Contents**
- **To Open Test Definition Editor**
- **To Define Test Specification**
- **To Define Test Contents**
- **Available Elements**
- **Available Variables**
- **To Define Test Output**

Module 7. Advanced Definitions and Operations

- **To Control External GPIB Devices**
- **To Call Execution Files**
- **To Perform Repeat Measurements**
- **Prober Control Script**
- **Thermo-trigger**

Module 8. Miscellaneous Operations

- **Function Status Indicator**
- **Run Option**
- **Automatic Data Export and Data Record**
- **Calibration**
- **Configuration**
- **XSLT Samples**
- **To Enable System Controller**
- **To Start Desktop EasyEXPERT**
- **To Use 415x Setup File Converter**



1 **Getting Started**



In This Module

- **To Launch EasyEXPERT**
- **To Specify/Create Workspace**
- **To Perform Application Test**
- **To Save/Recall Your Test Setup**
- **To Export/Import Your Preset Group**
- **To Export/Import Test Record**
- **To Perform Quick Test**
- **To Perform Tracer Test**
- **To Control Switching Matrix**
- **To Manage Data Display Window**

To Turn on/off B1500A/B1505A



The Standby button works to turn on the B1500A/B1505A when it is turned off. When the B1500A/B1505A is turned on, the Standby button works to terminate the EasyEXPERT software, Windows, and turn off the B1500A/B1505A.

After the B1500A/B1505A is turned on, log on Windows.

The default user is Agilent B1500 User with no password.

To Launch EasyEXPERT

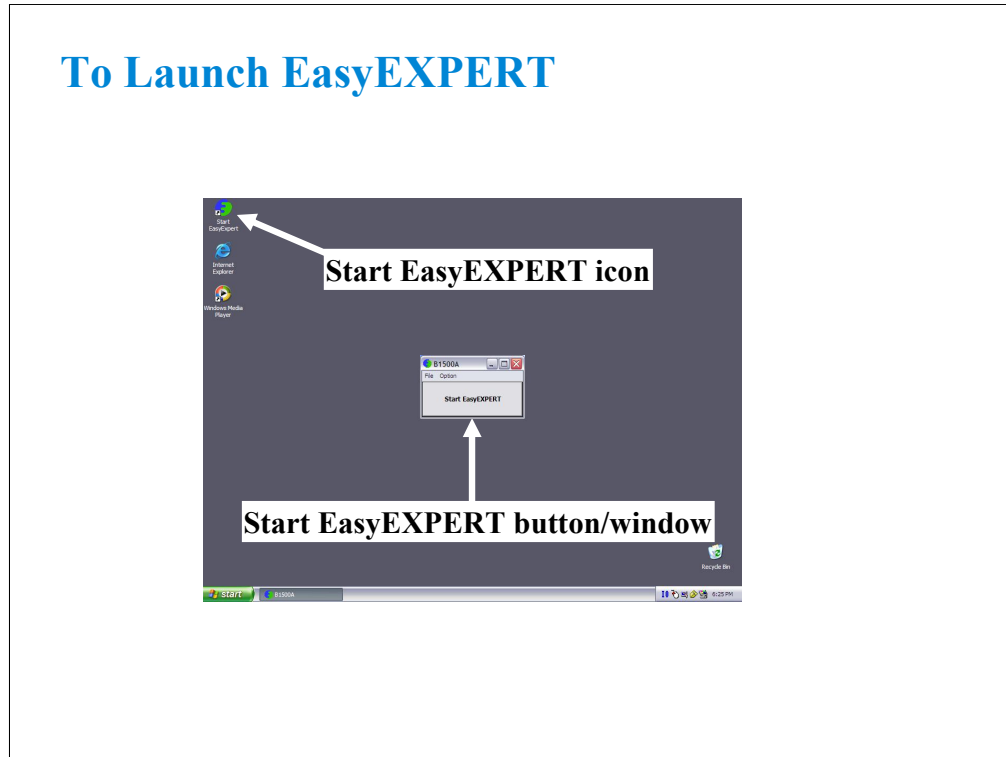

After logging on, click Start EasyEXPERT button to launch the EasyEXPERT software.

If you do not see the Start EasyEXPERT button, double click the Start EasyEXPERT icon to open the Start EasyEXPERT window.

This window has the File menu and the Option menu. The File menu is used to close this window. The Option menu provides the following functions.

- Auto Start of EasyEXPERT:** Enables or disables the automatic start function. If this label is checked, the function is enabled. From the next boot or logon, the Start EasyEXPERT window will be skipped and EasyEXPERT will be launched. To disable this function, use the Start EasyEXPERT window opened by the File > Exit menu on the EasyEXPERT main screen. This function is not effective for Desktop EasyEXPERT.
- Backup EasyEXPERT Database:** Used to make backup of the EasyEXPERT database.
- Restore EasyEXPERT Database:** Used to restore the EasyEXPERT database.

Note:

Desktop EasyEXPERT provides the following additional functions in the Option menu.

Execution Mode: Used to change the software execution mode.

Move EasyEXPERT Database: Used to move the EasyEXPERT database.

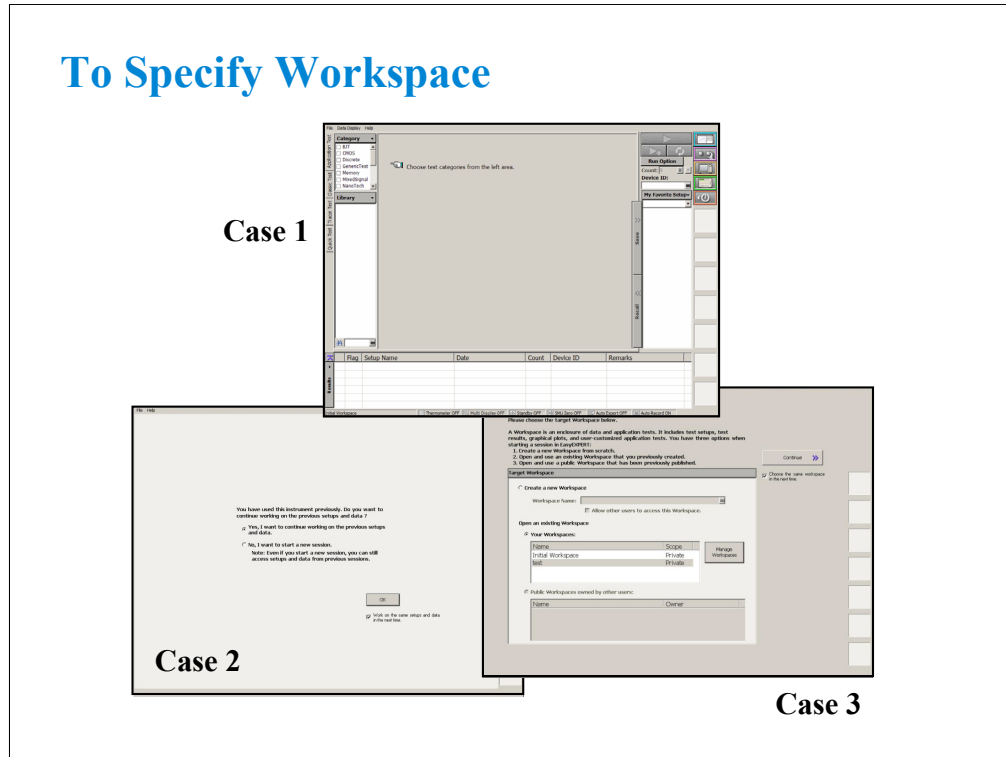

After launching the EasyEXPERT, you will see one of the above screens.

Case 1: If this is the first time to launch the EasyEXPERT

The LCD displays the EasyEXPERT main screen.

Case 2: If the B1500 has one workspace only

Select Yes, and click OK if you use the existing workspace.

The EasyEXPERT main screen is displayed.

Select No, and click Next if you want to create a new workspace.

See next slide.

Case 3: If the B1500 has some workspaces (more than one)

Select workspace you want to use, and click Continue.

The EasyEXPERT main screen is displayed.

If you create workspace, check the Create a new Workspace radio button, and click Continue.

To create a public workspace, check the *Allow other users to access this workspace* box. The public workspace can be used by all users.

To create a private workspace, delete the check from the *Allow other users to access this workspace* box.

Workspace is the space created in the B1500 internal hard disk drive, and is used to store the test setup, measurement result data, and so on. The workspace can be created and allocated for each user.

Work on the same setups and data in the next time and Choose the same Workspace in the next time:

If this check box is checked, the workspace selection screen will be skipped at the next startup and EasyEXPERT will be launched with the workspace used at the last operation. To perform this setup again, click the File > Close Workspace menu on the EasyEXPERT main screen.

To Create Workspace

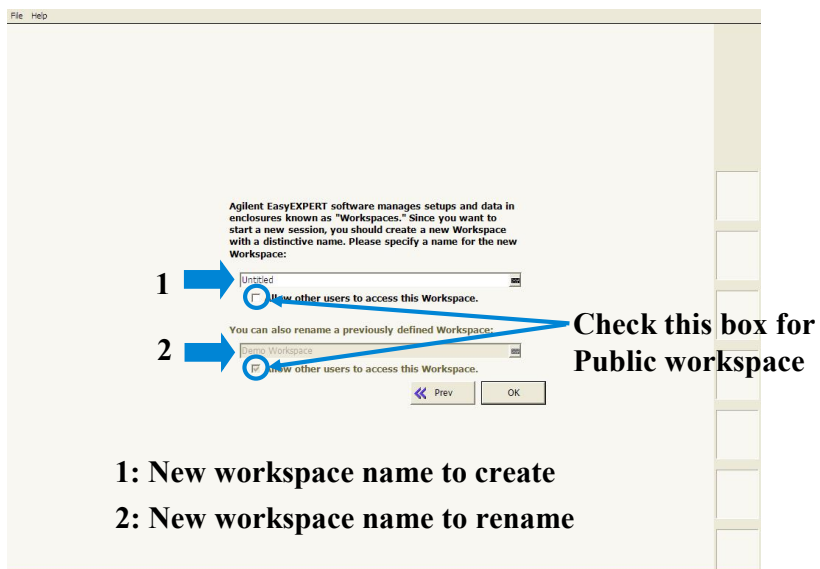

Enter the workspace name and click OK to create/rename the workspace.

If you want to create a public workspace, check the *Allow other users to access this workspace* box.

The public workspace can be used by all users.

If you want to create a private workspace, delete the check from the *Allow other users to access this workspace* box.

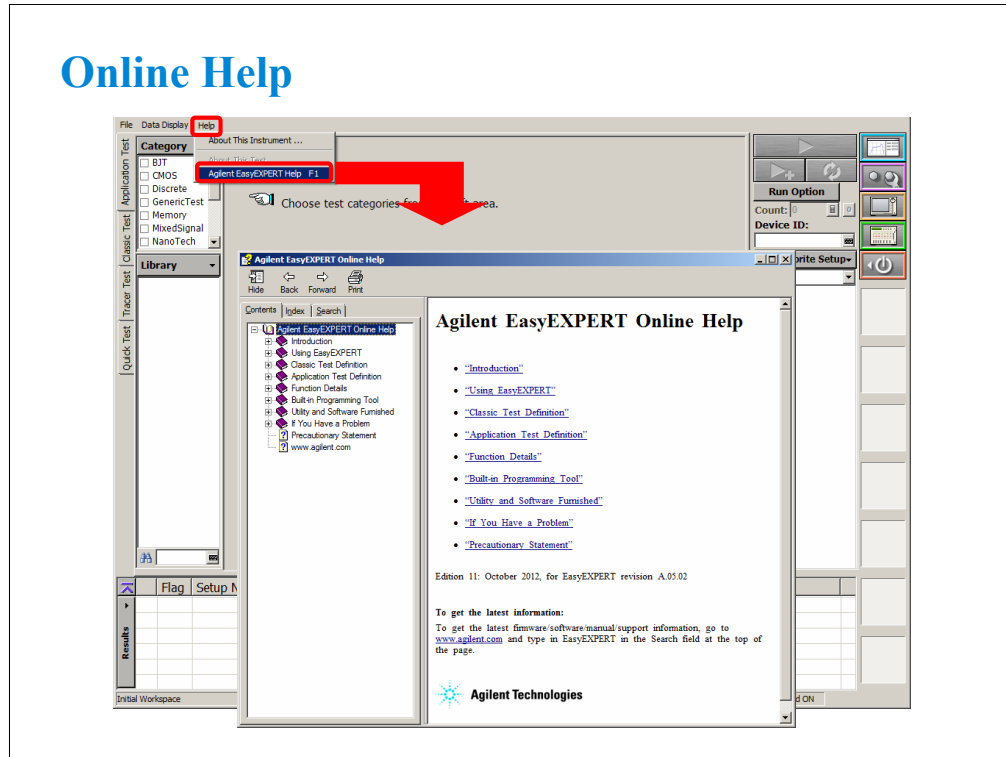

Online Help is available for the B1500 and EasyXPRT. Select Help > Agilent EasyXPRT Help menu to display the online help window. The online help provides the following information.

- Introduction describes overview, front view, rear view, and measurement units of the B1500.
- Using EasyXPRT provides the reference information of the Agilent EasyXPRT software.
- Classic Test Definition provides the reference information of the classic test setup GUI.
- Application Test Definition provides the reference information of the application test definition setup GUI.
- Function Details explains the measurement functions of the B1500 with EasyXPRT.
- Built-in Programming Tool provides the reference information of the built-in function, read out functions, and script programming statements.
- Utility and Software Furnished introduces the utility programs and software furnished with the B1500 and EasyXPRT.
- If You Have a Problem describes the problem solving information, the B1500 system maintenance information, and the error messages.

Application Test

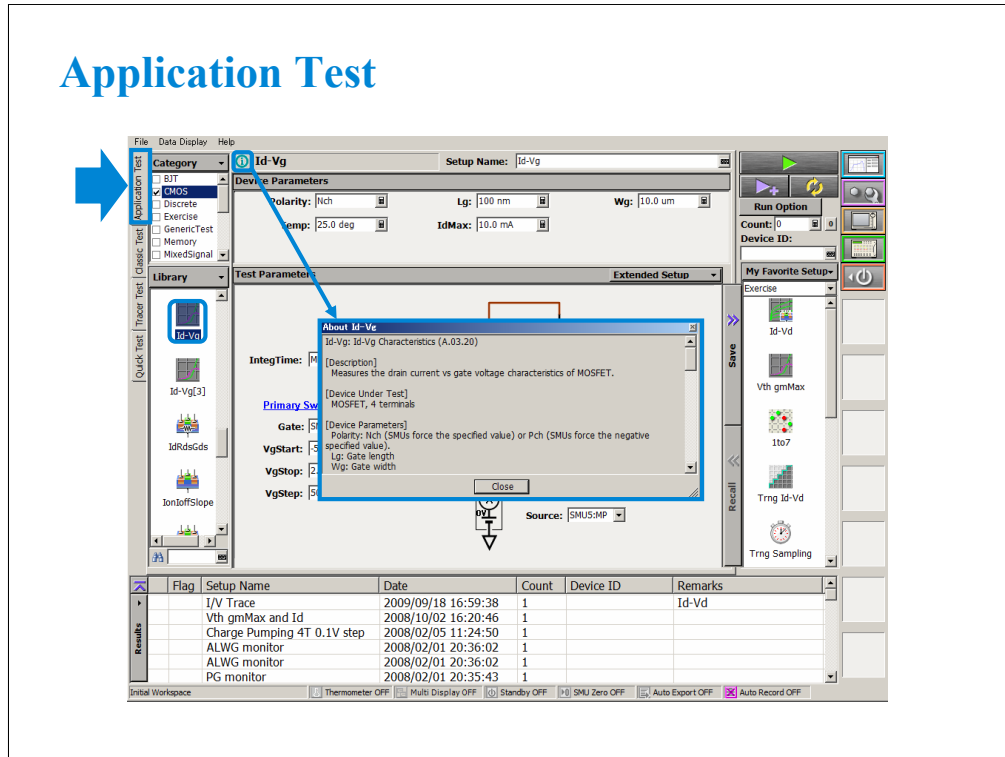

Application Test tab sets the application test mode.

Test definition can be selected by using Category and Library.

To know about the application test, click the (i) icon. This icon displays the message box that explains the application test definition. This function will help you to know what is and how to use the application test.

Typical Value Selection

You do not need to hit the keyboard.

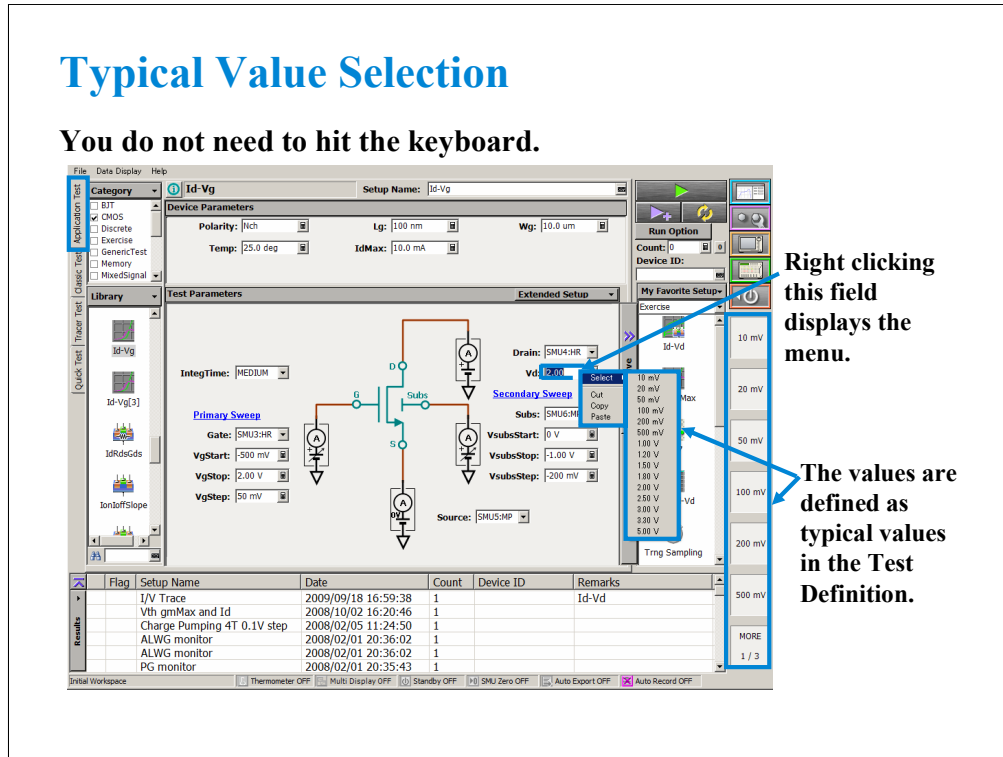

When you set a test condition of application test, you do not need to use keyboard. You can select the value from the typical values as shown below.

- Click the entry field of a setup parameter by using the touch screen or the mouse. This displays the typical values for the specified parameter on the softkeys.
- Select one of the softkeys.

Also you can use the following manner.

- Point the entry field of a setup parameter by using the mouse.
- Right click the mouse to display the popup menu.
- Click the Select menu to display the typical values for the specified parameter.
- Select one from the typical values.

Note:

The typical values are defined in the test definition. And you can change the values by using the Define typical values window opened by clicking the Typical Values button on the Test Specification screen of the Test Definition window. For the Test Definition window, see Module 5.

Screen Keyboard

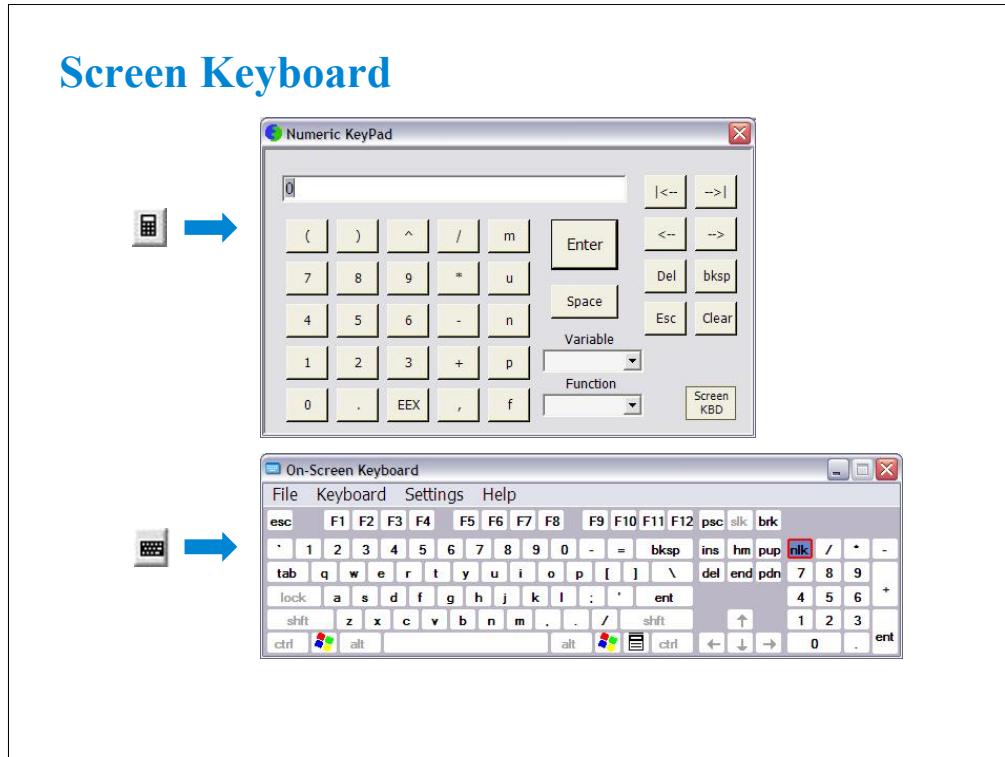

When you need to enter numeric characters in an entry field, you will see the icon at the right side of the entry field. This icon opens the Numeric Keypad. You can use this screen keypad instead of the USB keyboard.

When you need to enter alphabetic characters in an entry field, you will see the icon at the right side of the entry field. This icon opens the On Screen Keyboard. You can use this screen keyboard instead of the USB keyboard.

Note that the On Screen Keyboard is not available for DesktopEasyEXPERT runs on Windows 7 64-bit version.

To Perform Application Test

The screenshot displays the Agilent EasyExpert software interface for performing an application test. The interface is divided into several sections:

- Category:** A list of technology categories including BIT, CMOS, Discrete, Exercise, GenericTest, Memory, and MixedSignal.
- Device Parameters:** Fields for Polarity (High), Lg (100 nm), Wg (10.0 um), Temp (25.0 dep), and IdMax (10 mA).
- Test Parameters:** Fields for Gate (SMU3:HR), Start (500 mV), Top (2.00 V), and VgStep (500 mV).
- Circuit Diagram:** A schematic showing a device under test (DUT) connected to a gate terminal (G) and a drain terminal (D).
- Graph Plot:** An X-Y Graph Plot showing Id-Vg Characteristics (A.03.20) with a primary sweep. The graph displays multiple curves for different gate voltages. A marker is placed on the graph with the following data:

MARKER	V	I
1.700000000E+000	1.700000000	2.373200000E-002
- Test Record List area:** A table listing test records with columns for Flag, Setup Name, and Date.

Flag	Setup Name	Date
GUMMEL		2006/11/16 11:
I/V Trace		2009/09/18 16:
Id-Vd		2006/11/08 13:
IDVD		2006/11/10 14:
IDVD-Pulse		2006/11/22 19:
IDVG		2006/11/15 17:

Step 1: Click Application Test tab.

Step 2: Select one or more technology categories, and select a desired test from the list of tests associated with the selected technology categories.

Step 3: Change the setup parameters (Device parameters and Test parameters) if you want.

Step 4: Connect DUT, and click the Single button. The B1500 starts the selected test.

After the measurement, the test result data is displayed on the Data Display window. And the Test Result Editor shown in the next page is displayed on the lower left area of the B1500 screen if the Auto Record function or the Auto Export function is set to ON. Check the status indicator at the bottom of the screen.

Step 5: Analyze the measurement result data.

Test Result Editor

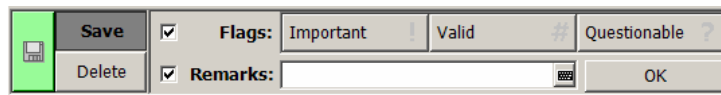

- **Save/Delete**
- **! Important**
- **# Valid**
- **? Questionable**
- **Remarks**
- **OK**

The Test Result Editor provides the following GUI to set a flag and remarks to the test result record. Set the flag and remarks to the test record.

•Save button and Delete button

Divides test records into groups, Save and Delete.

Test records in Save-group are always listed in the lower area of the EasyEXPERT main screen.

Test records in Delete-group can be listed when Results > Filter > Show Deleted Data is checked.

•Flags buttons

The following buttons are available while the left check box has been checked. You can set one of the following flags.

•Important ! Button

Sets the important flag (!) to the test result record.

•Valid # button

Sets the valid flag (#) to the test result record.

•Questionable ? Button

Sets the questionable flag (?) to the test result record.

•Remarks field

This field is effective while the left check box has been checked. You can enter characters into this field. The characters will be recorded as the Remarks value of the test result record.

•OK button

Applies the setup on the Test Result Editor, and closes this dialog box.

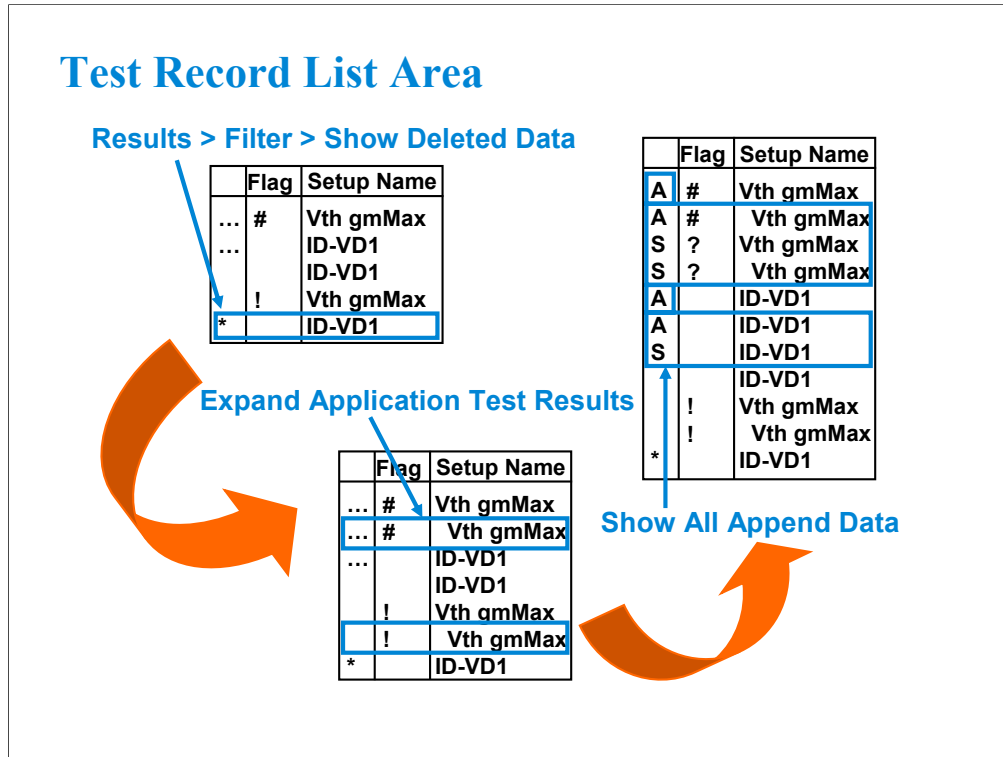

The test result records are listed in the test record list area. The area also lists the following data.

- Append measurement data marked with ...
- Deleted data marked with * if Results > Filter > Show Deleted Data is checked
- Test name defined in the application test definition if Results > Filter > Expand Application Test Results is checked

If Results > Filter > Show All Append Data is checked, all append data will be listed and the symbol will be changed to A for the data obtained by the Append measurement or S for the data obtained by the Single measurement.

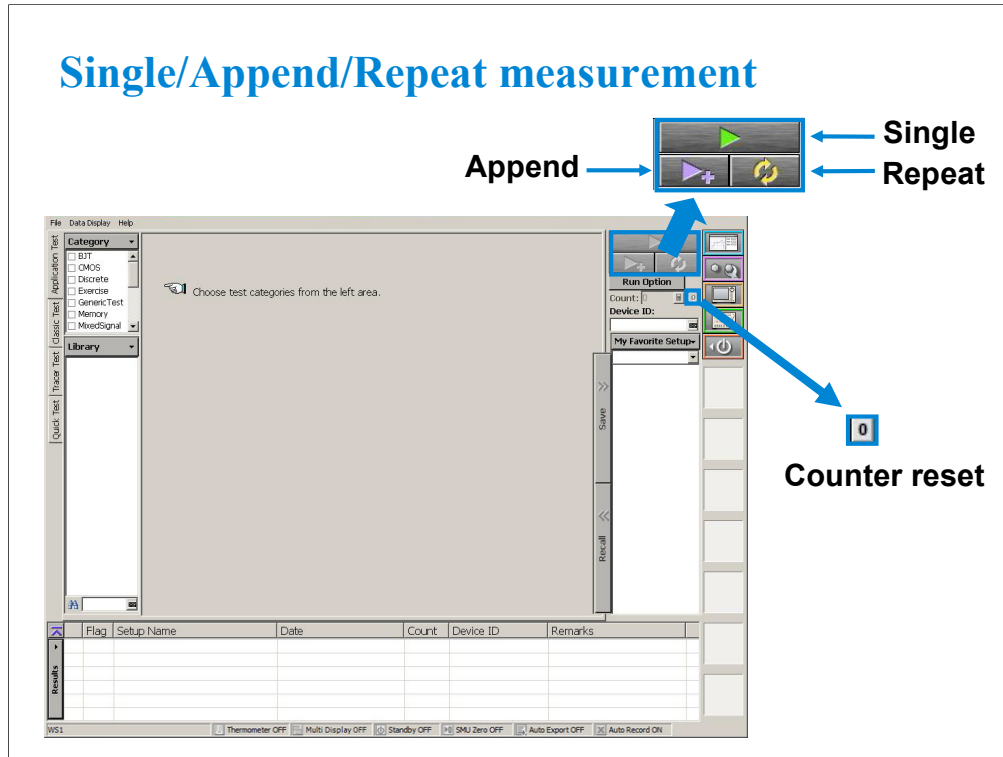

The EasyEXPERT provides three execution modes, Single, Append, and Repeat.

Single button triggers a single measurement.

Append button triggers an append measurement. The measurement results will be appended to the Data Display window that shows the previous measurement results. The Data Display window can have maximum 10 layers for displaying measurement results.

Repeat button opens the Repeat Measurement Setup dialog box used to set the repeat measurement condition. To perform the repeat measurement, see Module 7.

To abort measurement, click Stop button that appears instead of the Single button.

To reset the counter, click the reset button.

To Save/Recall Your Test Setup

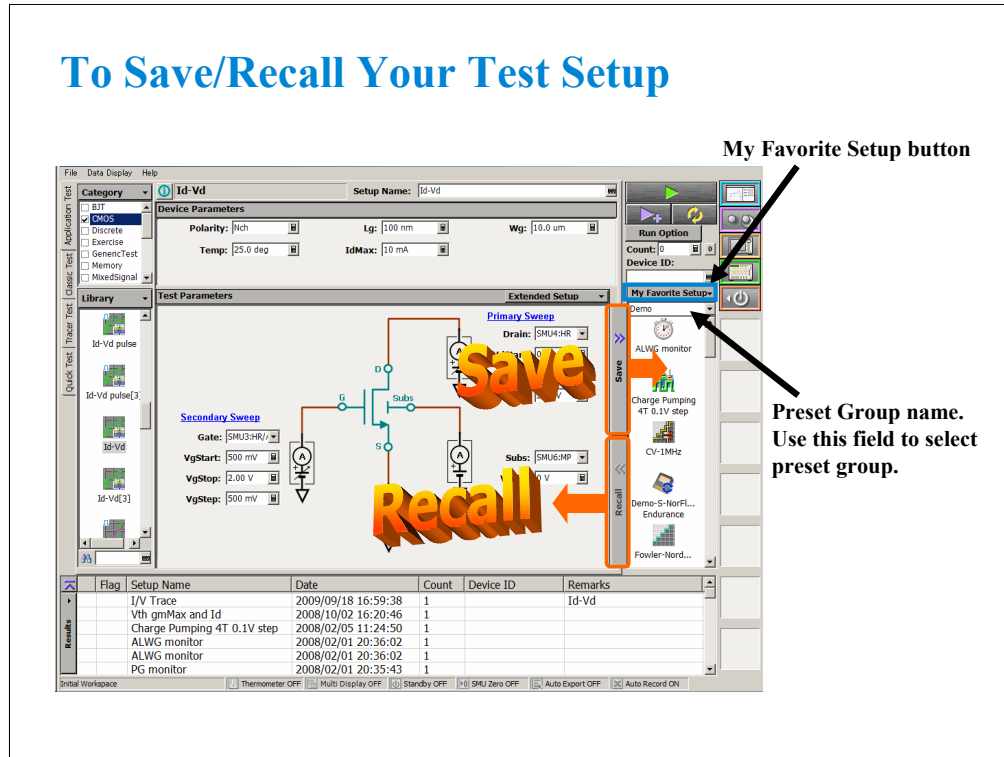

The test setups you create or modify **MUST** be saved in a preset group (My Favorite Setup).

To save the setup, click the Save button.

To recall the setup, click the Recall button.

You can organize the setups by using the My Favorite Setup button.

To select the available preset group, use the field below the My Favorite Setup button. In the above example, the Demo group is selected and listed in the My Favorite Setup list.

To rename, duplicate, or delete the setups, and to add, rename, duplicate, delete, import, or export the preset group, use the function of the My Favorite Setup button menu or the Organize Preset Group dialog box shown in the next page.

To organize preset group for test setup

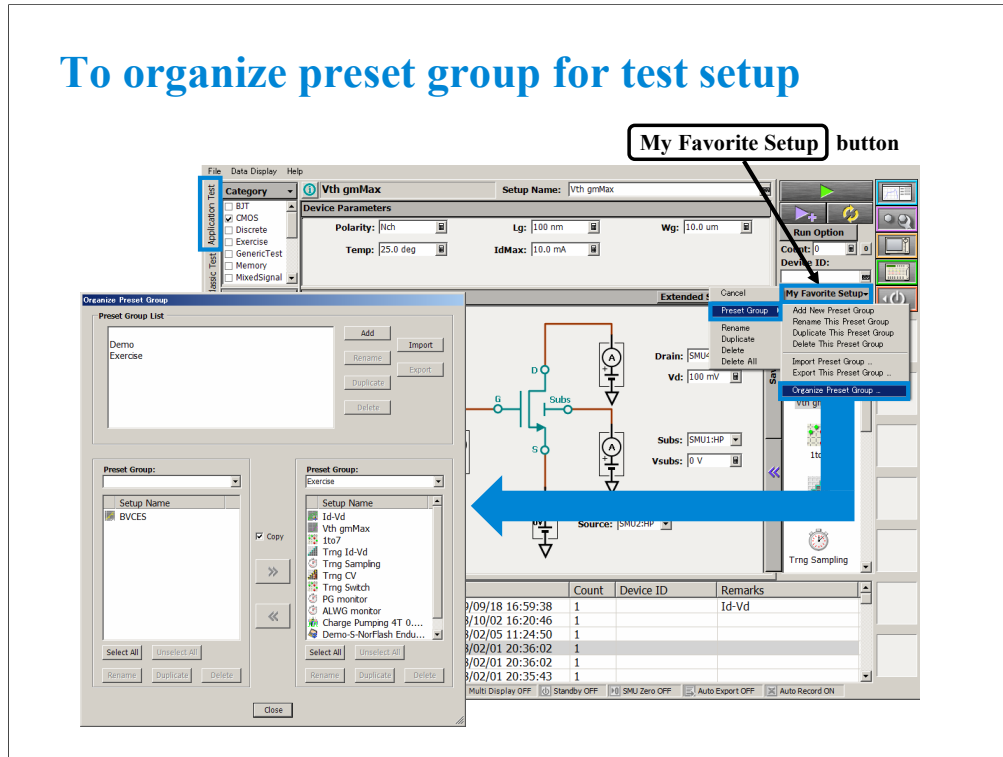

This dialog box is opened by clicking the My Favorite Setup > Preset Group > Organize Preset Group... menu, and is used to organize the preset group.

- Preset Group List

Lists the preset groups saved in the workspace. The Add, Rename, Duplicate, Delete, Import, and Export buttons are available to organize the preset groups.

- Copy

Sets the operation of the >>> button and the <<< button. They work as Copy when this check box is checked, and as Move when this check box is blank.

- >>>

Copies or moves the preset setup selected in the left Preset Group box to the right Preset Group box.

- <<<

Copies or moves the preset setup selected in the right Preset Group box to the left Preset Group box.

- Close

Closes the Organize Preset Group dialog box.

- Preset Group

Lists the preset setups saved in the preset group. The Select All, Unselect All, Rename, Duplicate, and Delete buttons are available to select or organize the setups saved in the preset group.

To Export/Import Your Preset Group

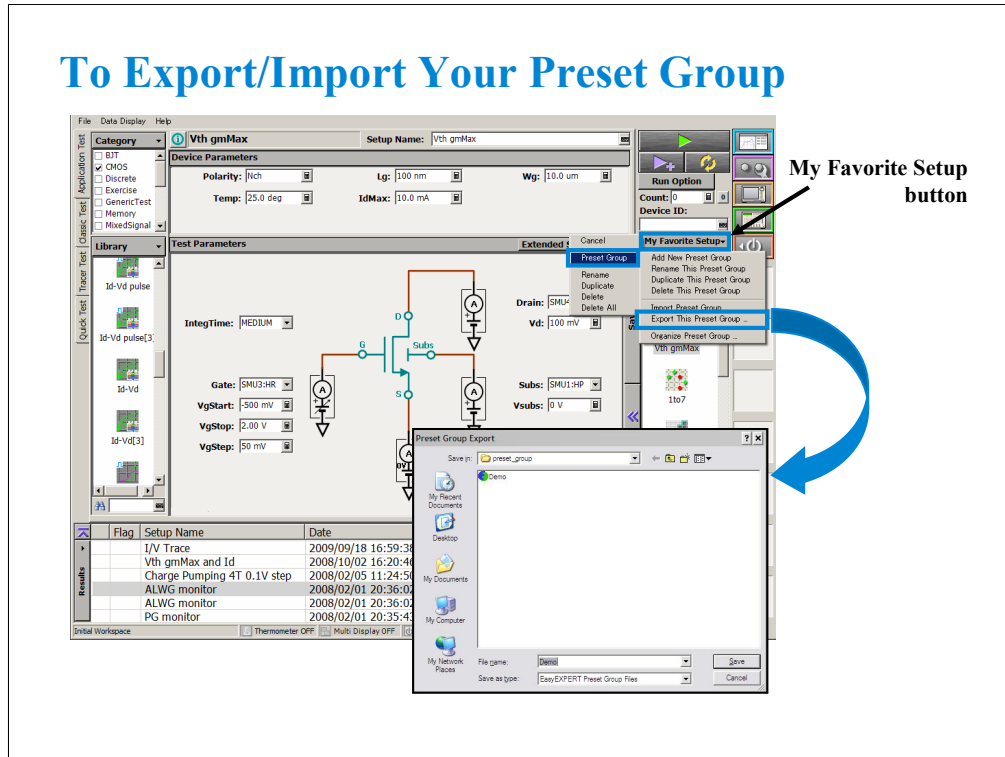

You can export/import your preset group.

To export the present preset group, click the My Favorite Setup > Preset Group > Export This Preset Group..., and specify the folder and the name of the preset group to export.

To import the preset group, click the My Favorite Setup > Preset Group > Import Preset Group..., and specify the preset group to import.

To Export/Import Test Record

The screenshot shows a test setup software interface. On the left, there are panels for 'Category', 'Device Parameters', and 'Library'. The main area displays a circuit diagram with various components and measurement points. On the right, there are panels for 'Run Option' and 'My Favorite Setup'. Below the circuit diagram is a data table with columns for 'Flag', 'Setup Name', 'Date', and 'Count'. An arrow points to the 'Id-Vd' record in the table.

Flag	Setup Name	Date	Count
	Id-Vd	2006/11/08 13:17:59	1
	IRVR	2006/11/08 13:59:57	1
	Parallel	2006/11/08 18:27:18	3
	REKLV	2006/11/09 15:21:31	2
	IDVD	2006/11/10 14:52:24	1
	Zero-check	2006/11/13 18:20:05	1

1. Select data record to export, and right click.
 2. Select Transport Data > Export As xxxx.
- To export multiple data, select Transport Data > Folder Export.

To export the test result record, specify the data records and select the Transport Data > Export As xxxx menu.

You can save the data records as an EasyEXPERT file, a CSV file, a XML spreadsheet file, or a XML file created by using the specified XML style sheet.

You can import the data record exported as the EasyEXPERT file or the XML spreadsheet file.

To import the file, select the Transport Data > Import... Then the Test Result Import dialog box is opened. On the dialog box, select the file to import.

You can read by using a text editor or a spreadsheet software as shown above. This example reads a test record exported to a CSV file.

Note:

To export multiple test records, select Transport Data > Folder Export..., and specify the destination folder and file names automatically set. Then the multiple test records can be exported to the specified folder.

Class Exercise

Perform Application Test.

1. **Connect device (MOSFET). See the following pages.**
2. **Open Id-Vd test definition in the CMOS library.**
3. **Change the setup (SMU, output value, etc.)**
4. **Create your preset group, and save your setup.**
5. **Click  button to start a single measurement.**
6. **Perform this exercise for the Vth gmMax test definition.**

Note:

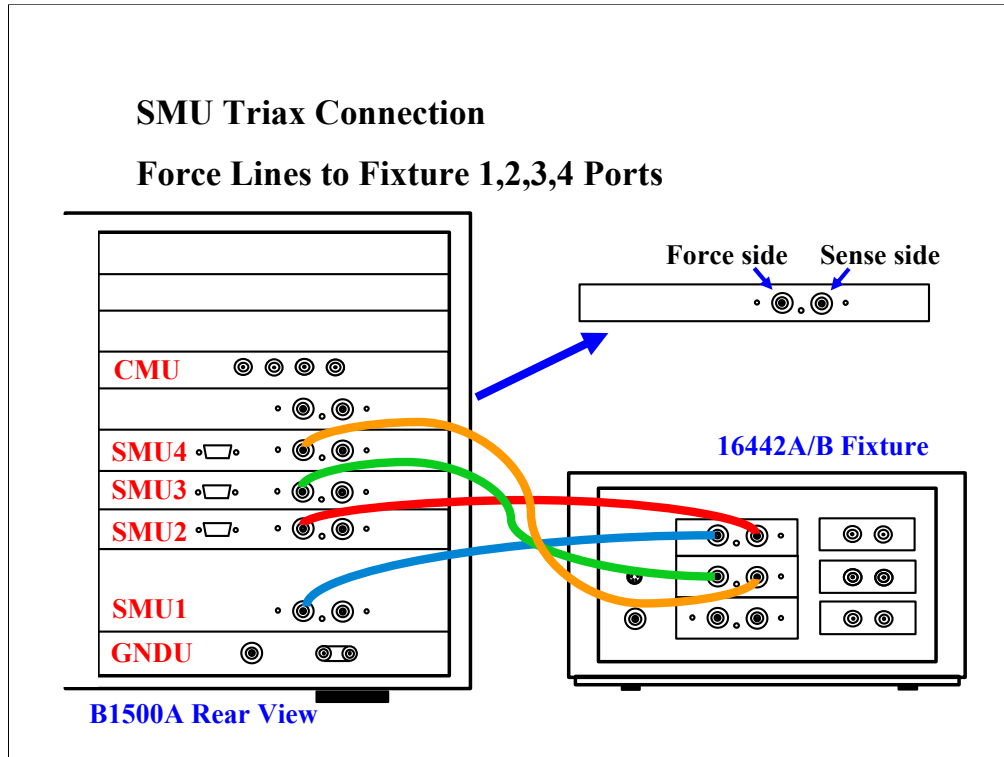

For the non-Kelvin connections, connect only the Force lines, leaving the Sense lines open.

Connect corresponding numbers. On the 16442A/B fixture use the numbers labeled 1 - 6, not 1 - 3.

Your B1500A may not match the SMU configuration shown in this figure. Note that SMU1 is the module top of the GNDU (ground unit). The SMU number become large from bottom to top as shown.

This is the SMU cable setup that will be used in the remainder of the class exercises.

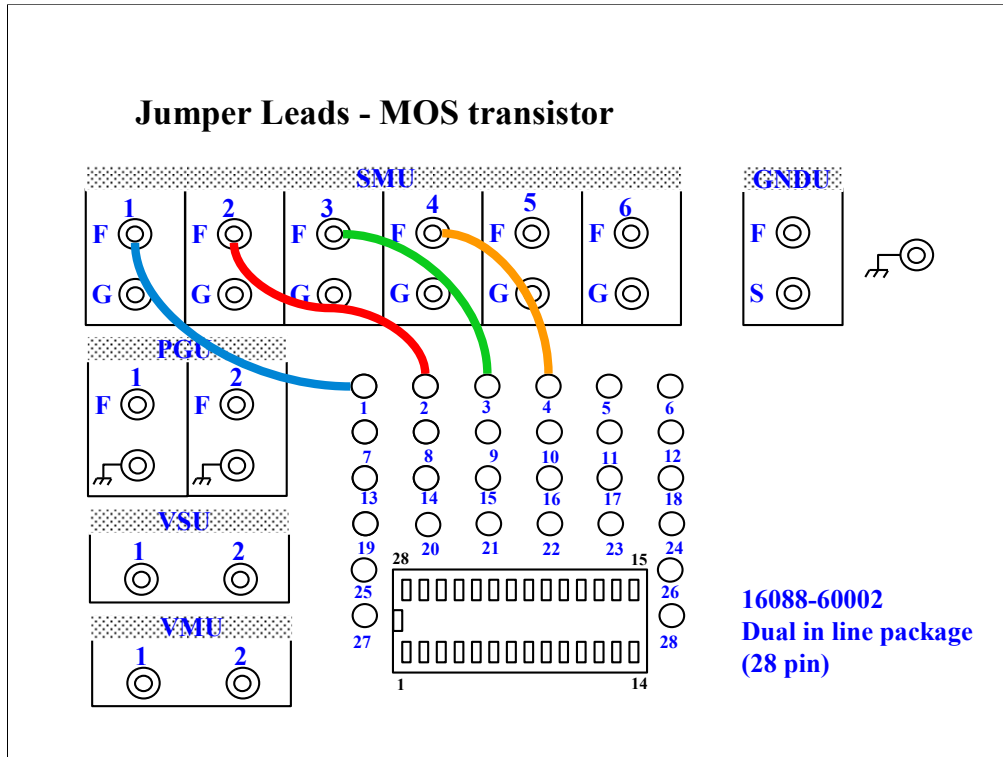

With the 16442A/B fixture, note that there are two SMU numbering schemes....3 SMUs with force and sense, or six SMUs with force only. For this class example we will use the six (6) SMU scheme. On older fixtures, this scheme is shown in light blue lettering. In newer fixtures, this scheme is shown in white reverse background lettering.

Device Orientation and Insertion

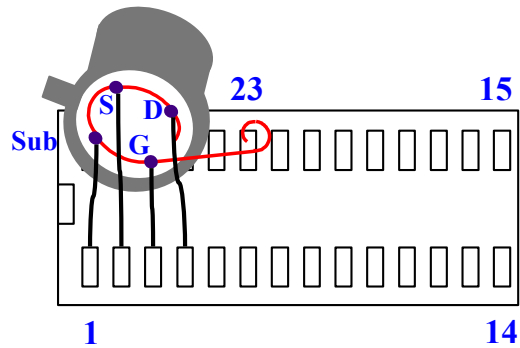

Insert the transistor last,
AFTER connecting the
cables and leads. Remove
the shorting wire after
insertion in the socket.

- 1: Substrate
- 2: Source
- 3: Gate
- 4: Drain

The MOS FET leads must be re-arranged into a straight line as shown.

IMPORTANT:

The MOS FET is highly sensitive to electrostatic damage. Touching the bare leads can definitely destroy the device. The device comes with a special shorting wire attached. Bend the leads the way you want, insert the device in the socket, and then remove the shorting wire. The wire has a tab. Just grab the tab and pull straight out. The wire will spiral out as you pull.

Once the shorting wire is removed, you must use a wrist strap when handling the device.

Result Example

1. check

2. select

3. change

3. change

3. change

3. change

4. create

5. save

Flag	Setup Name	Date	Count	Device ID	Remarks
	Id-Vd	2006/11/08 13:17:59	1		
	IRVR	2006/11/08 15:59:57	1		
	Parallel	2006/11/08 18:27:18	3		
	REKELV	2006/11/09 15:21:31	2		
	IDVD	2006/11/10 14:52:24	1		
	Zero-check	2006/11/13 18:20:05	1		

Test result data (record) is automatically saved after measurement.

1. Check the CMOS check box.
2. Select Id-Vd (or Vth gmMax) and click the Select button.
3. Change the SMU setting as follows.
Substrate: SMU1
Source: SMU2
Gate: SMU3
Drain: SMU4
4. Create your preset group (ex. Exercise).
5. Save the changed setup to your preset group.

After this class exercise, the Id-Vd setup and the Vth gmMax setup will be saved in your preset group.

Result Example

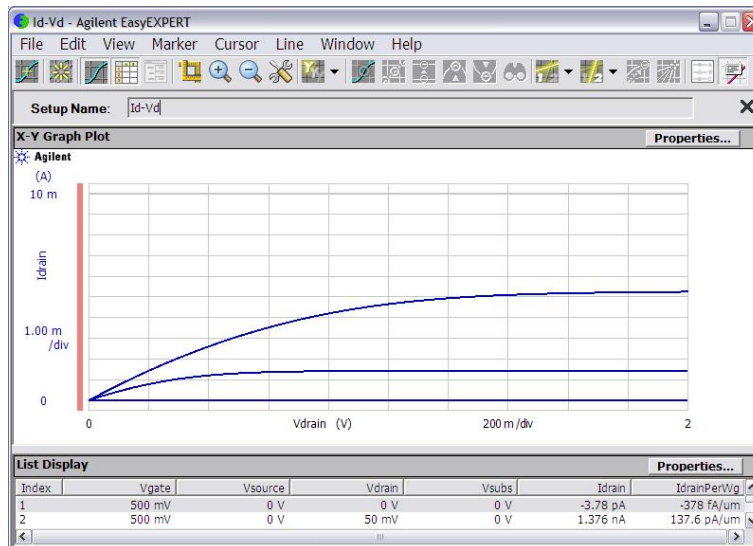

This is the Id-Vd measurement result example of the following source setup.

Gate voltage: 0.5 V to 2 V, 0.5 V step

Drain voltage: 0 V to 2 V, 0.05 V step

Source voltage: 0 V

Substrate voltage: 0 V

To Perform Quick Test

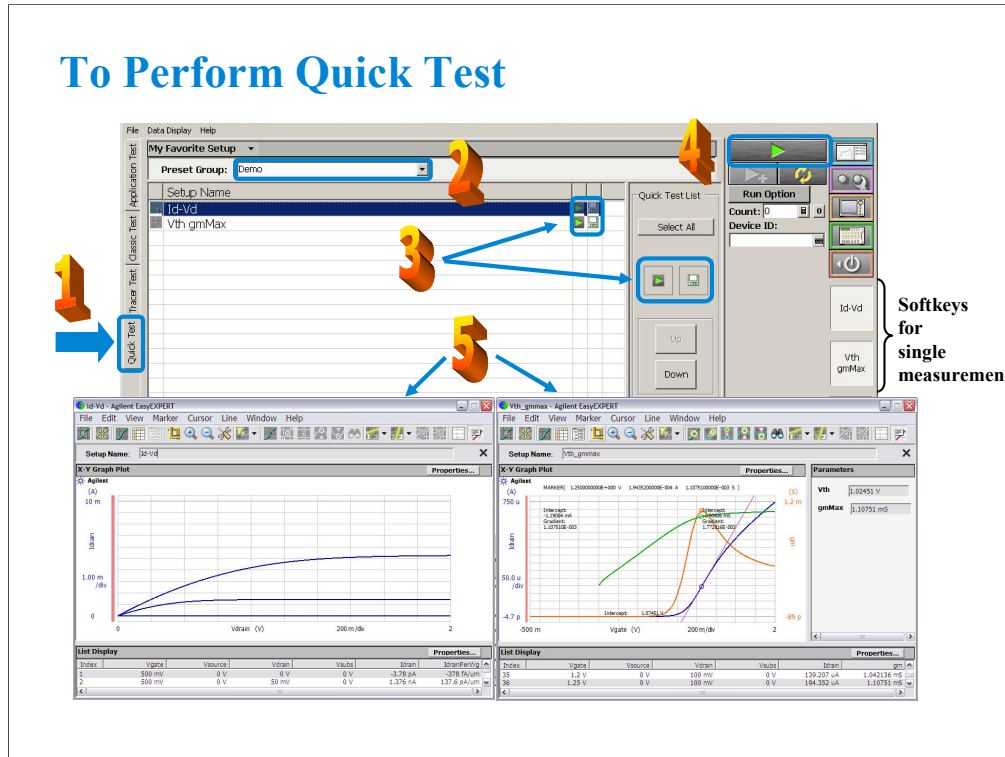

Step 1: Click Quick Test tab.

Step 2: Select the Preset Group.

Step 3: Set the execution ON/OFF and the data record ON/OFF for each test.

Step 4: Connect DUT, and click the Single button. The B1500 starts the selected tests from top to bottom in the list.

After the measurement, the test result data is displayed on the Data Display window. And the Test Result Editor is displayed on the lower left area of the B1500 screen if the Auto Record function or the Auto Export function is set to ON. Check the status indicator at the bottom of the screen.

Step 5: Analyze the measurement result data.

The softkeys placed right side of the LCD are used to trigger a single measurement of the associated test.

To organize preset group for test setup

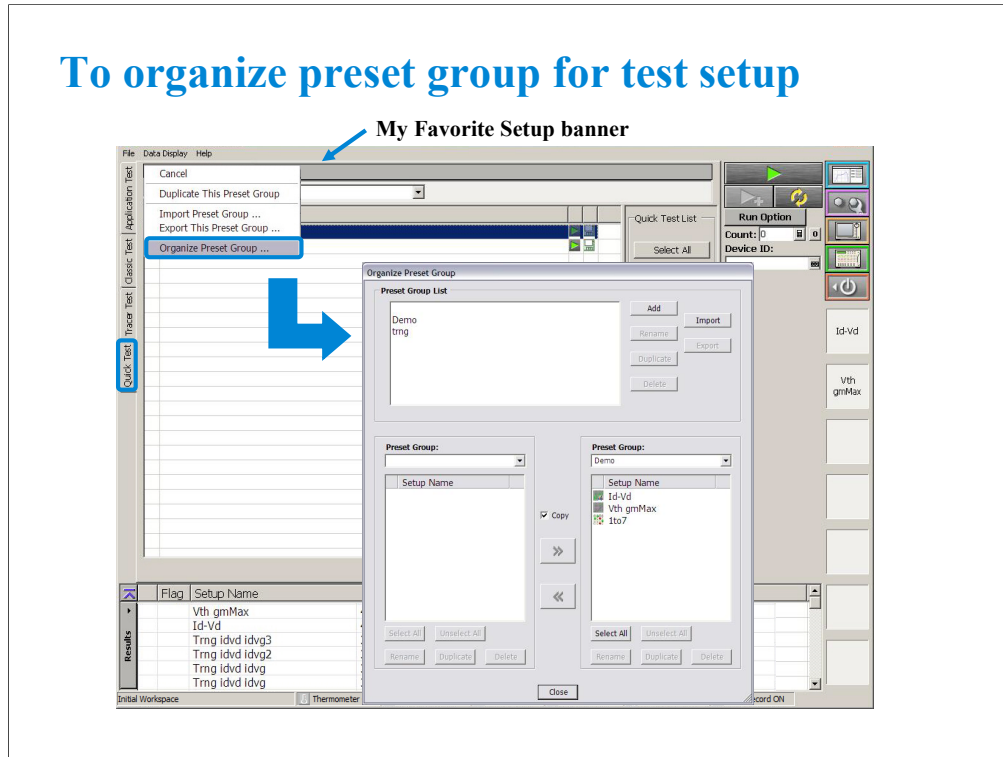

This dialog box is opened by selecting the Organize Preset Group function of the My Favorite Setup banner menu, and is used to organize the test preset group.

- Preset Group List

Lists the preset groups saved in the workspace. The Add, Rename, Duplicate, Delete, Import, and Export buttons are available to organize the preset groups.

- Copy

Sets the operation of the >> button and the << button. They work as Copy when this check box is checked, and as Move when this check box is blank.

- >>

Copies or moves the preset setup selected in the left Preset Group box to the right Preset Group box.

- <<

Copies or moves the preset setup selected in the right Preset Group box to the left Preset Group box.

- Close

Closes the Organize Preset Group dialog box.

- Preset Group

Lists the preset setups saved in the preset group. The Select All, Unselect All, Rename, Duplicate, and Delete buttons are available to select or organize the setups saved in the preset group.

Class Exercise

Perform Quick Test.

- 1. Use the device connection of the previous exercise.**
- 2. Open your preset group.**
- 3. Edit your preset group as you want (changing the test execution order etc.).**
- 4. Save your preset group.**
- 5. Perform Quick Test.**

Note:

Result Example

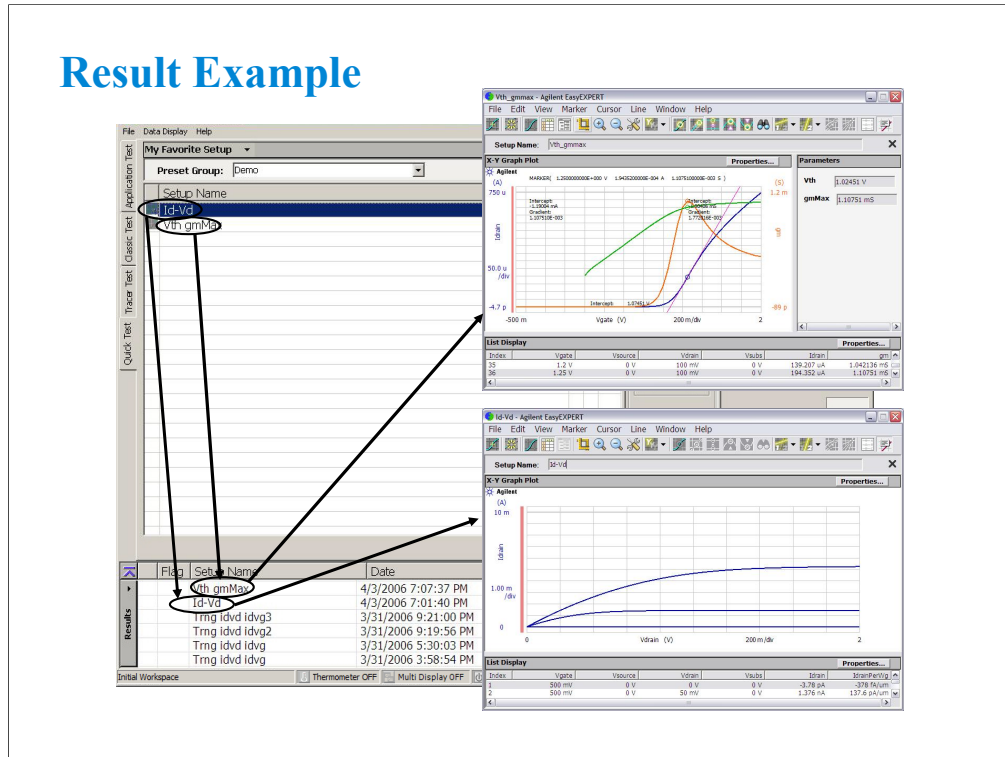

Note:

To Perform Tracer Test

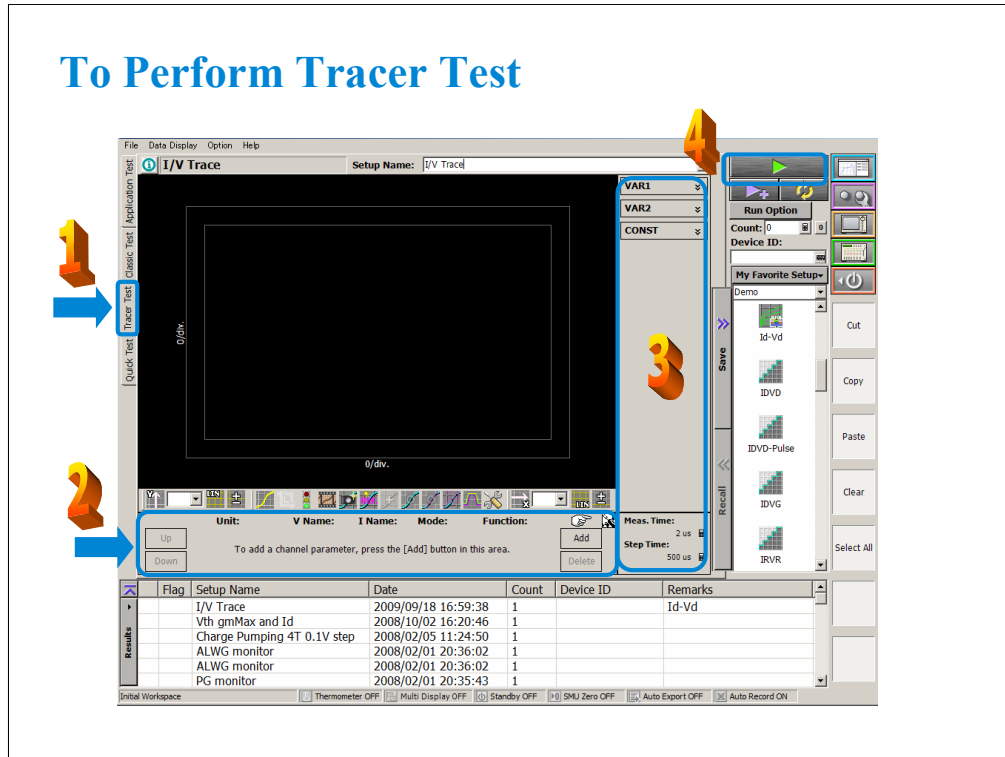

Step 1: Click Tracer Test tab.

Step 2: Select and define the source and measurement channels.

Step 3: Set the source output parameters.

Step 4: Connect DUT, and click the Single button to start a single measurement.

After the measurement, the test result data is displayed on the graph area. And the Test Result Editor is displayed on the lower left area of the B1500 screen if the Auto Record function or the Auto Export function is set to ON. Check the status indicator at the bottom of the screen.

Setup Example

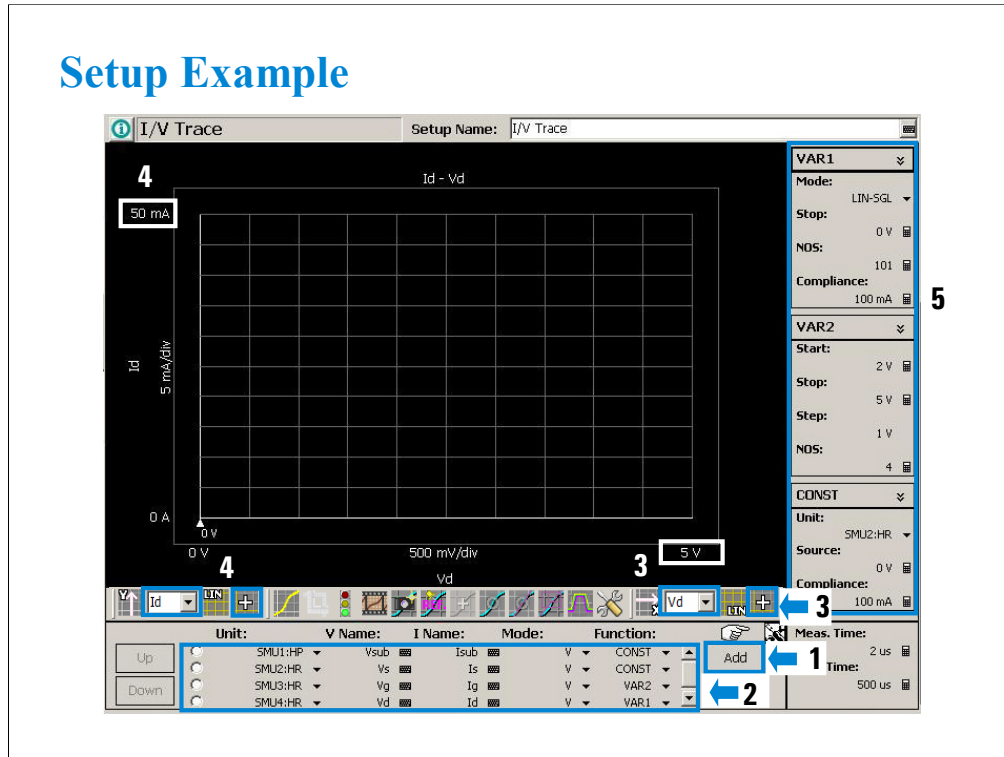

You can complete the measurement setup by the following steps.

1. Click Add button and add SMU1, SMU2, SMU3, and SMU4.
2. Set the channel definition. See below.
3. Set the X axis parameter, polarity and maximum value.
4. Set the Y axis parameter, polarity and maximum value.
5. Define the VAR1, VAR2, and CONST setup. See below.

Channel definition:

SMU1: Vsub, Isub, V mode, CONST
 SMU2: Vs, Is, V mode, CONST
 SMU3: Vg, Ig, V mode, VAR2
 SMU4: Vd, Id, V mode, VAR1

Source setup:

VAR1: Stop 0 V, Compliance 100 mA
 VAR2: Start 2 V, Stop 5 V, NOS 4, Compliance 10 mA
 CONST: Compliance 100 mA

This is the MOSFET Id-Vd measurement setup example.

This measurement setup is effective for the device connection of the Application Test class exercise.

Class Exercise

Perform Tracer Test.

1. Complete the measurement setup shown in the previous page.
2. Highlight the VAR1 Stop entry field and leave it.
3. Click  button to start a repeat measurement.
4. Rotate the rotary knob to change sweep range.

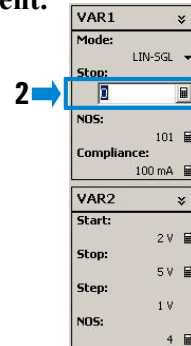
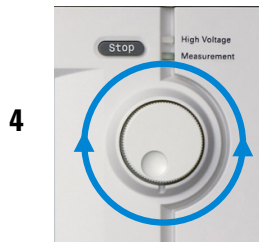

Note:

Result Example

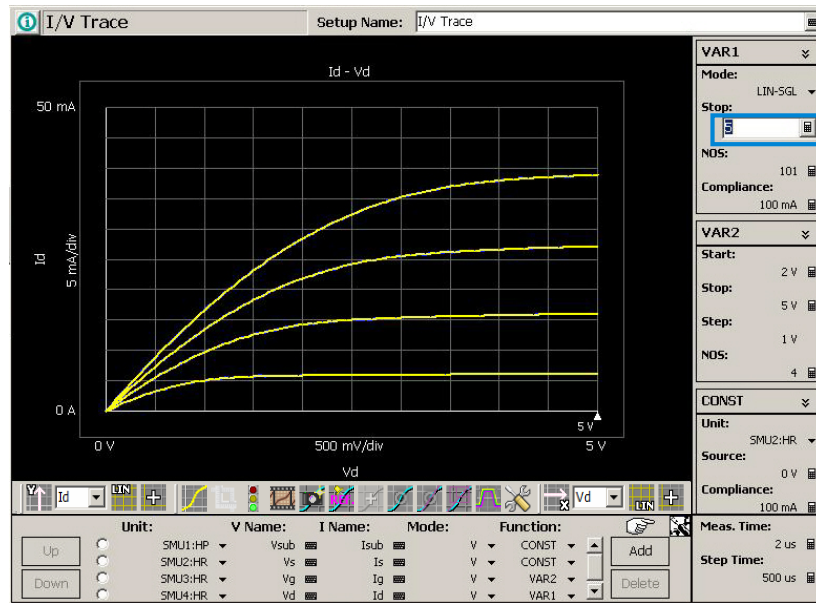

Note:

Graph Setup and Option Tools

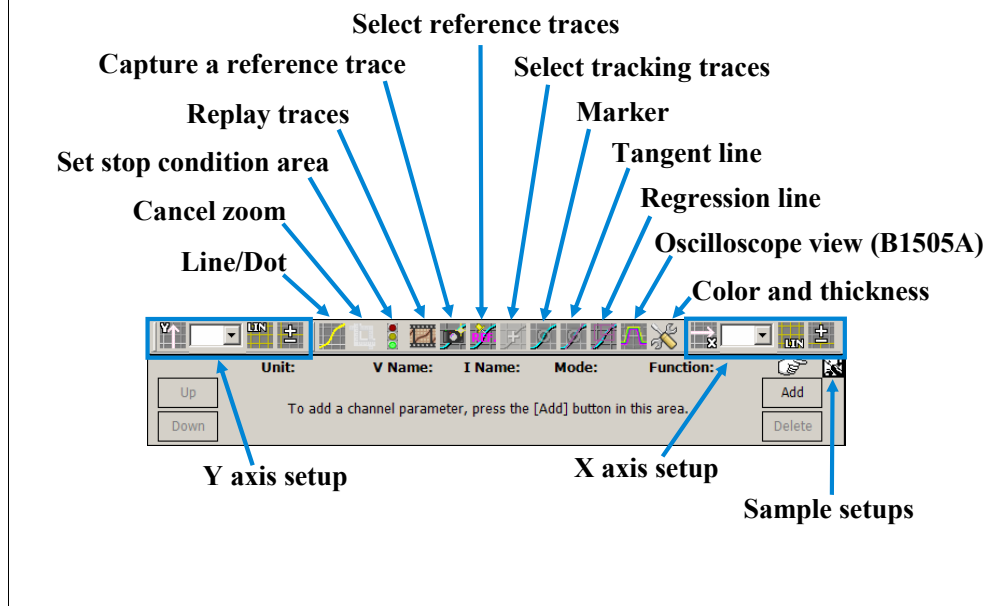

X or Y axis setup: Used to set the X or Y direction forward or reverse, the variables for X-Y plot, the graph scale linear or log, and the plot polarity positive, negative, or both.

Line/Dot: Used to switch line or dots of trace.

Cancel zoom: This button is available for the graph zoomed in, and is used to return the graph scale to the original setting. The graph can be zoomed in by the point and drag operation.

Set stop condition area: See “To Use Stop Condition” page.

Replay traces: Opens/closes the dialog box used for managing the record and replay of traces.

Capture a reference trace: Used to capture the trace as the reference trace. Up to 10 traces can be captured.

Select reference traces: Opens/closes the dialog box used for managing the reference traces.

Select tracking traces: Opens/closes the dialog box used for managing the tracking traces.

Marker: Enables/disables the marker.

Tangent line: Enables the marker and enables/disables the tangent line.

Regression line: Enables the marker and enables/disables the regression line.

Oscilloscope view: Opens/closes the Oscilloscope View window used for monitoring the waveforms of output signals.

Color and thickness: Opens/closes the dialog box for changing graph color and trace thickness.

Sample setups: See “Sample Setups” page.

Sample Setups

For B1500A

MOSFET: ID-VDS, ID-VGS, ID(off)-VDS, BVDSS
Diode: IF-VF, IR-VR
BJT: IC-VCE, IC-VBE, IC-VCEO, BVCEO

For B1505A

MOSFET: ID-VDS, ID-VGS, ID(off)-VDS, BVDSS
Diode: IF-VF, IR-VR
IGBT: IC-VCE, IC-VGE, IC(off)-VCE, BVCES
BJT: IC-VCE, IC-VCEO, BVCEO, IC-VCBO, BVCBO
GaN FET (N1267A): ID-VDS, ID(off)-VDS,
ID-VDS Current Collapse,
FET Current Collapse Oscilloscope View
GaN Diode (N1267A): IF-VF, IR-VR, IF-VF Current Collapse,
Diode Current Collapse Oscilloscope View

The Sample setup button displays the sample setup menu. Clicking a setup name in the menu applies its setup to the tracer test environment.

Arithmetic Operation for Tracer Test

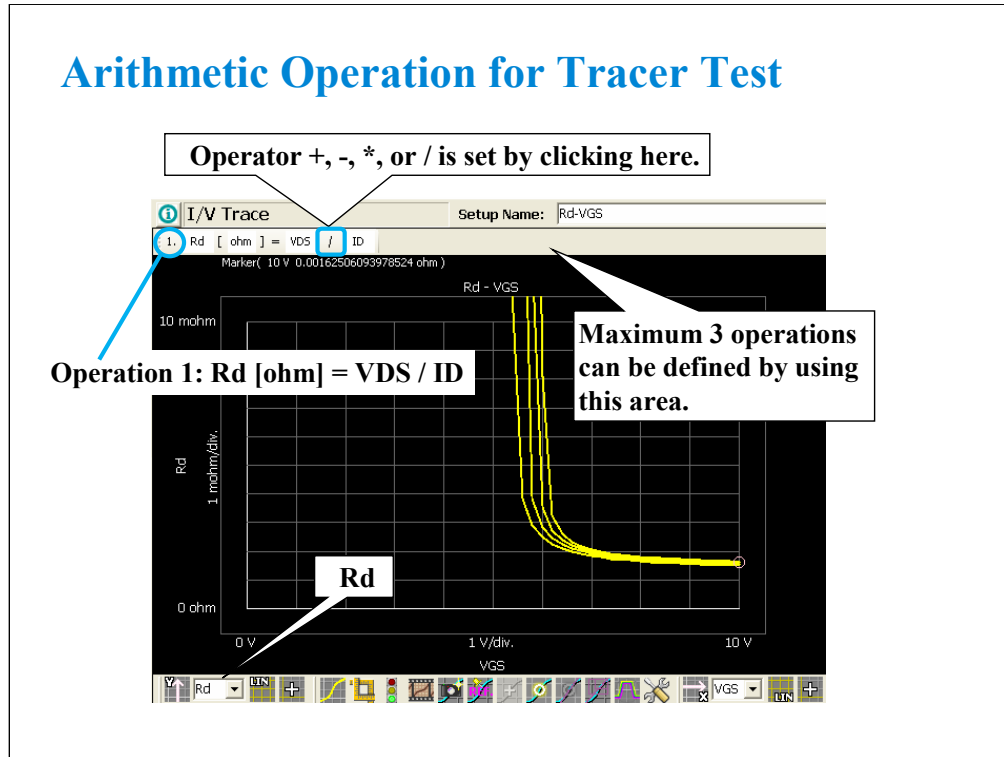

Click the Option > Arithmetic Operation > Operation N (N: 1, 2, or 3) menu, the arithmetic operation area appears at the top of the graph. This area is used to define arithmetic expressions using the measurement result data. This function is useful to graphically display parameters given by the expressions.

An expression can be defined by two operands and an operator + (addition), - (subtraction), * (multiplication), or / (division). The following elements can be the operand.

- Measurement data
- Source data
- Real literal constant (e.g. 2, 0.123, or 100E-3)
- Operation 1 result, for the expression of Operation 2 and/or Operation 3
- Operation 2 result, for the expression of Operation 3

Note: "NaN" is returned for the invalid calculation results.

Note: To disable the operation, click the Option > Arithmetic Operation > Operation N menu and uncheck the Operation N menu.

Line/Dot

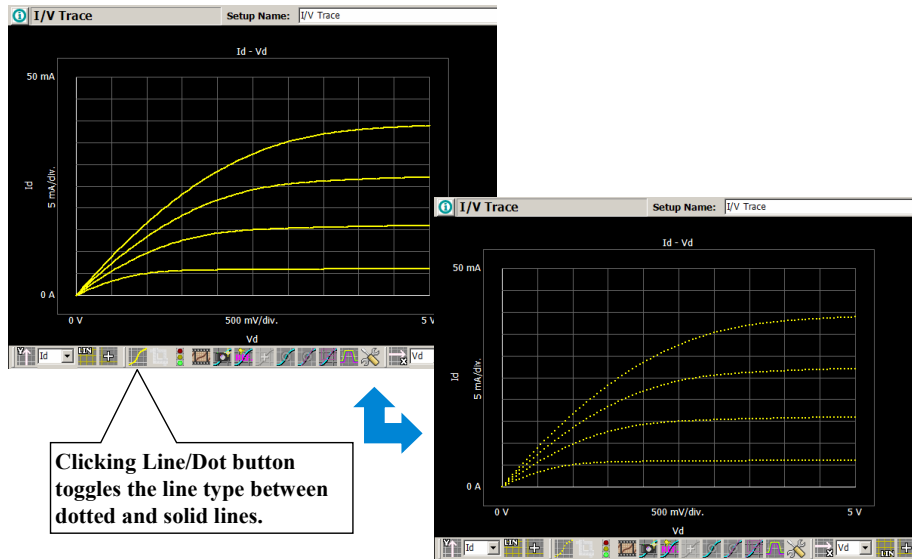

Note:

Zoom in and Cancel zoom

Point and drag operation zooms in the graph.

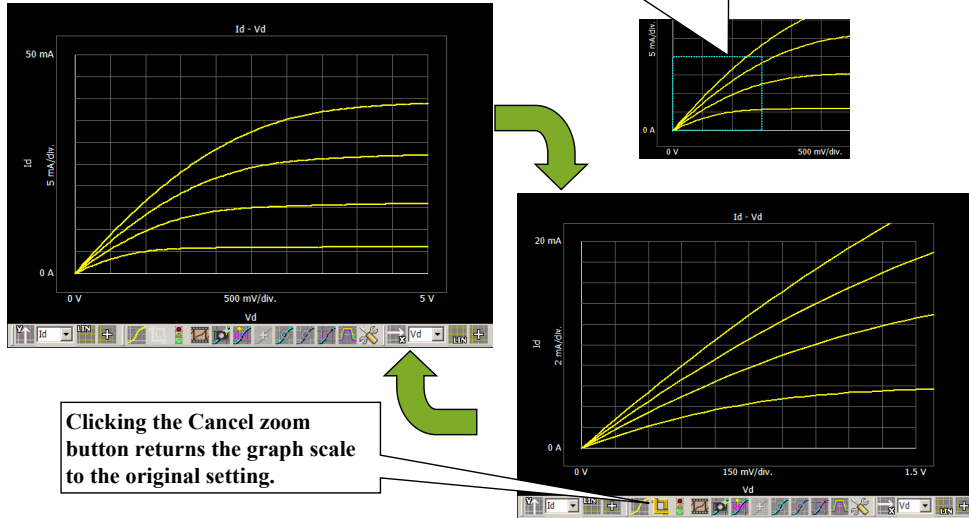

Clicking the Cancel zoom button returns the graph scale to the original setting.

Note:

Graph Minimum and Maximum

Clicking the minimum or maximum scale number pops up a dialog.

Vertical Max.
0.1

Enter the number and close the dialog.

e.g. Maximum is changed on Y-scale.

Clicking the Cancel zoom button returns the graph scale to the original setting.

Note:

Marker

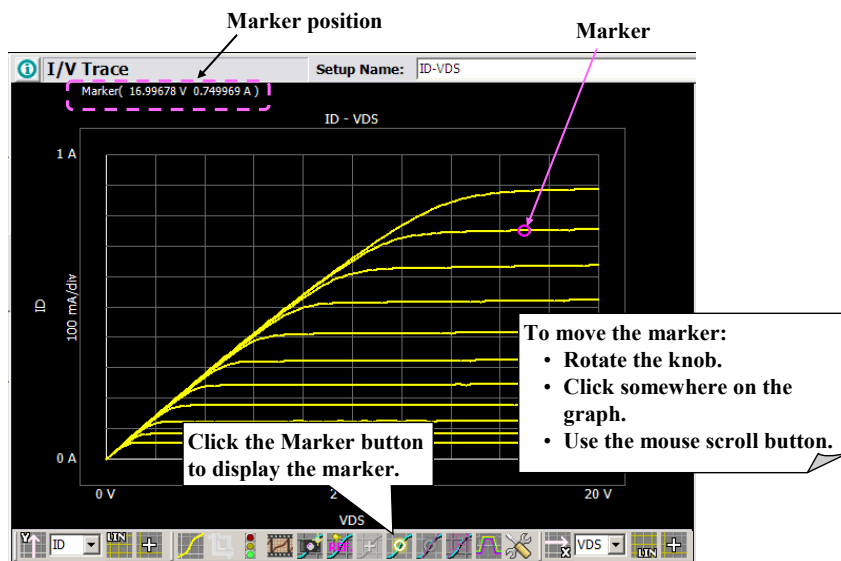

Note:

Tangent Line

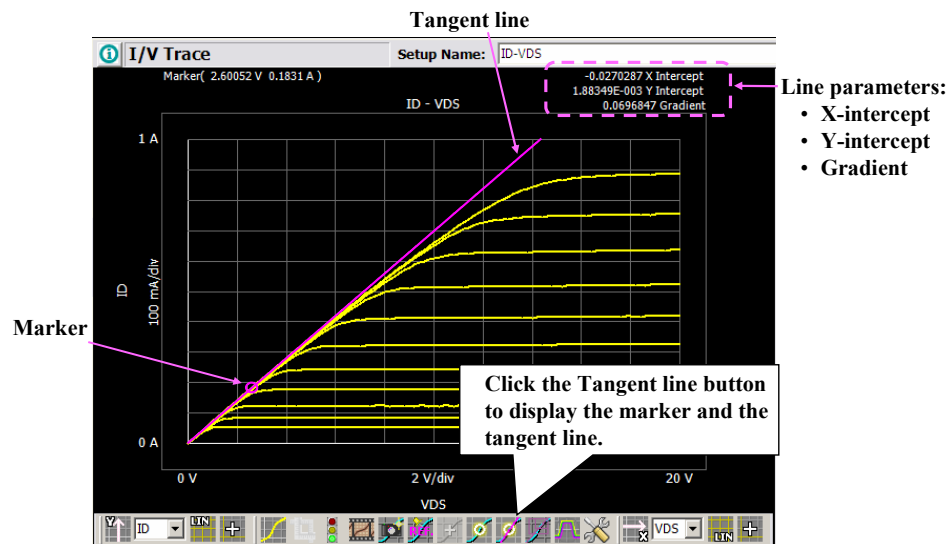

Note:

Regression Line

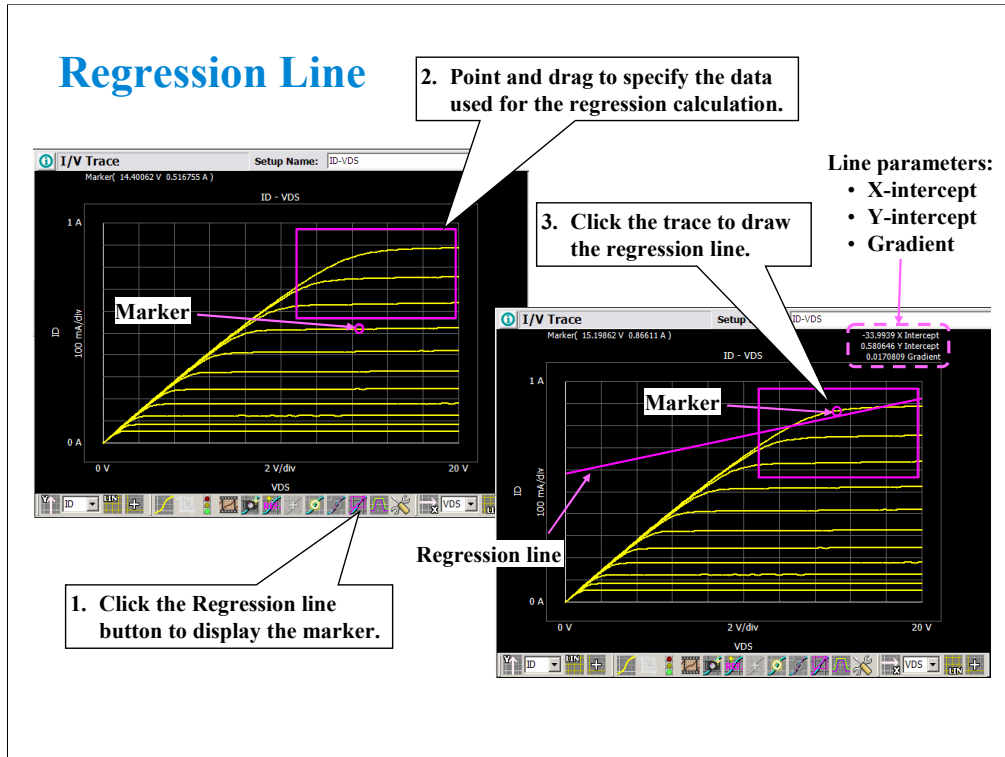

Note:

Oscilloscope View – B1505A

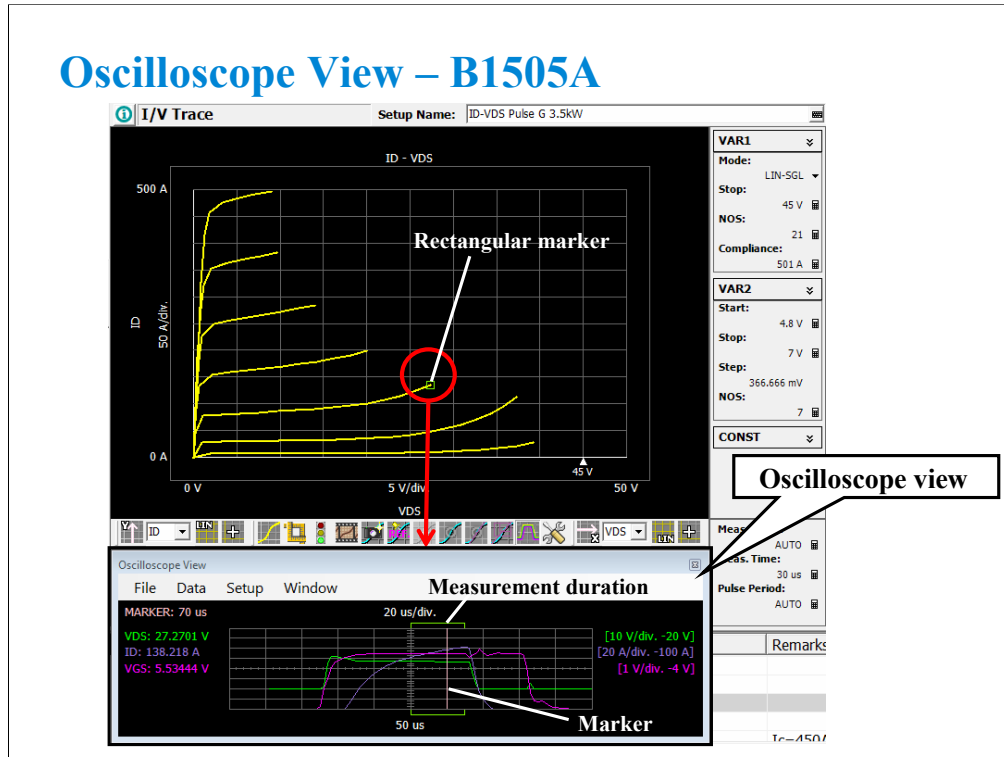

Oscilloscope view is opened/closed by clicking the Oscilloscope View button or selecting the Option > Oscilloscope View menu on the Tracer Test screen.

This function monitors a point of the pulsed sweep measurement or the pulsed spot measurement and displays its waveform. The monitoring point is specified by a rectangular marker on the trace. This function is used for monitoring the time relationship between multiple channel outputs/measurements, the change of the output level for the gate drive channel, and so on.

This function is valid for using one or more VPULSE or IPULSE channels. And this function is not available for the following measurement resources.

- HRSMU, HPSMU, MPSMU
- MFCMU
- WGFMU
- SPGU
- GNDU

Data names set in the V Name and I Name fields of the channel area are used to specify the target monitored signals.

During executing the tracer test, the waveforms within the specified duration are displayed in this window graphically.

To Use Stop Condition



Green



1. Click the Set stop condition area button.



Yellow



2. Point and drag to specify the abnormal region.

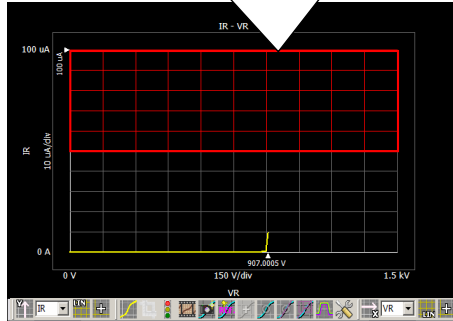

Red

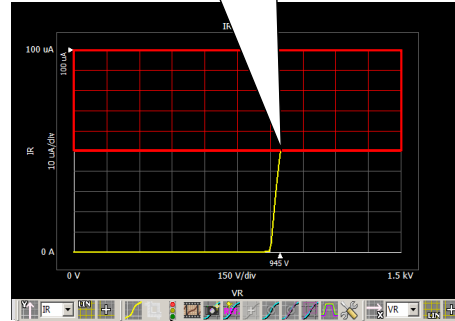

Red

Note:

To Use Replay Function

Automatic trace record ON/OFF
Open trace record
Save trace record

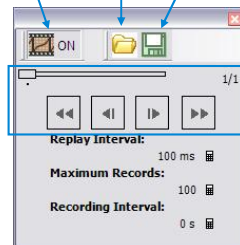

Selects recorded trace.

N/M

N: Trace number

M: Total number of recorded traces

Click the Replay traces button to open this dialog box.

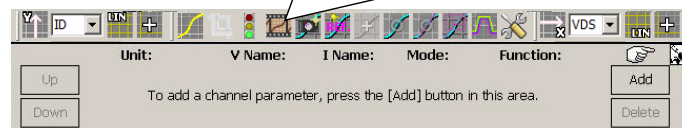

Use the slide bar or the arrow buttons (<<, <, >, >>) to select the recorded trace to display.
Long-clicking the << or >> button changes the trace sequentially.

Replay Interval is used to set the time interval of the long-click operation of the << and >> buttons.
Maximum Records is used to set the maximum record count. After the record number reaches this value, the record numbers are shifted to the newer side and the oldest record is deleted. This number is always assigned to the last record.

Recording Interval is used to set the time interval of the automatic trace record operation.

To Use Reference Trace

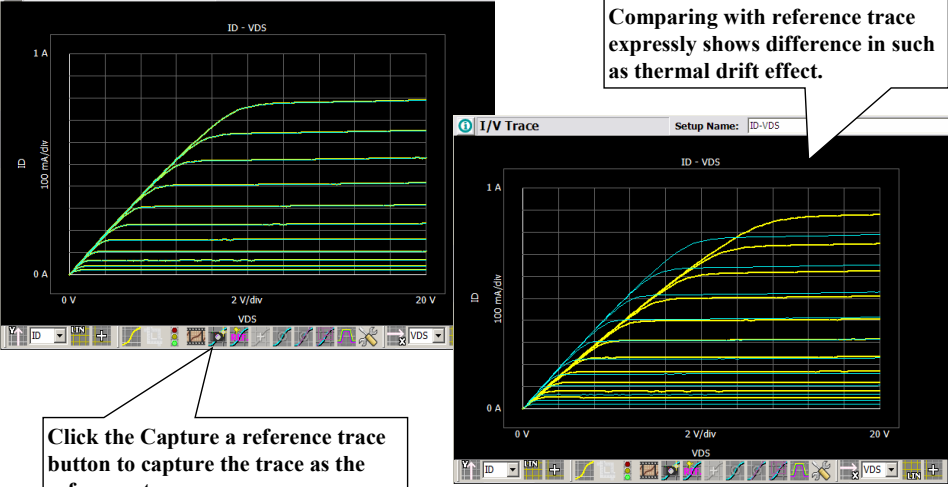

The image contains two screenshots of an I/V Trace window. The left screenshot shows a graph with multiple green traces. A callout box points to a button in the toolbar with the text: "Click the Capture a reference trace button to capture the trace as the reference trace." The right screenshot shows the same graph with one trace highlighted in yellow. A callout box points to the yellow trace with the text: "Comparing with reference trace expressly shows difference in such as thermal drift effect."

Click the Capture a reference trace button to capture the trace as the reference trace.

Comparing with reference trace expressly shows difference in such as thermal drift effect.

Note:

Select reference traces and Select tracking traces

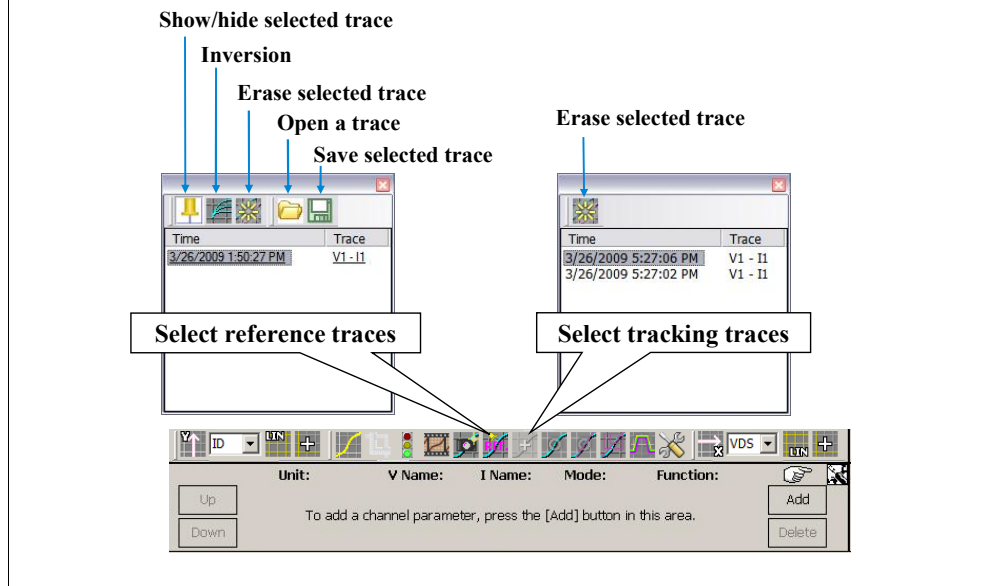

Reference trace means the trace set as the reference by using the Capture a reference trace button. Up to 10 traces can be captured.

The Select tracking traces button is available for the measurement result which contains at least two traces by the append measurement. Tracking trace means each trace of this measurement result.

GUI of Source Setup Area

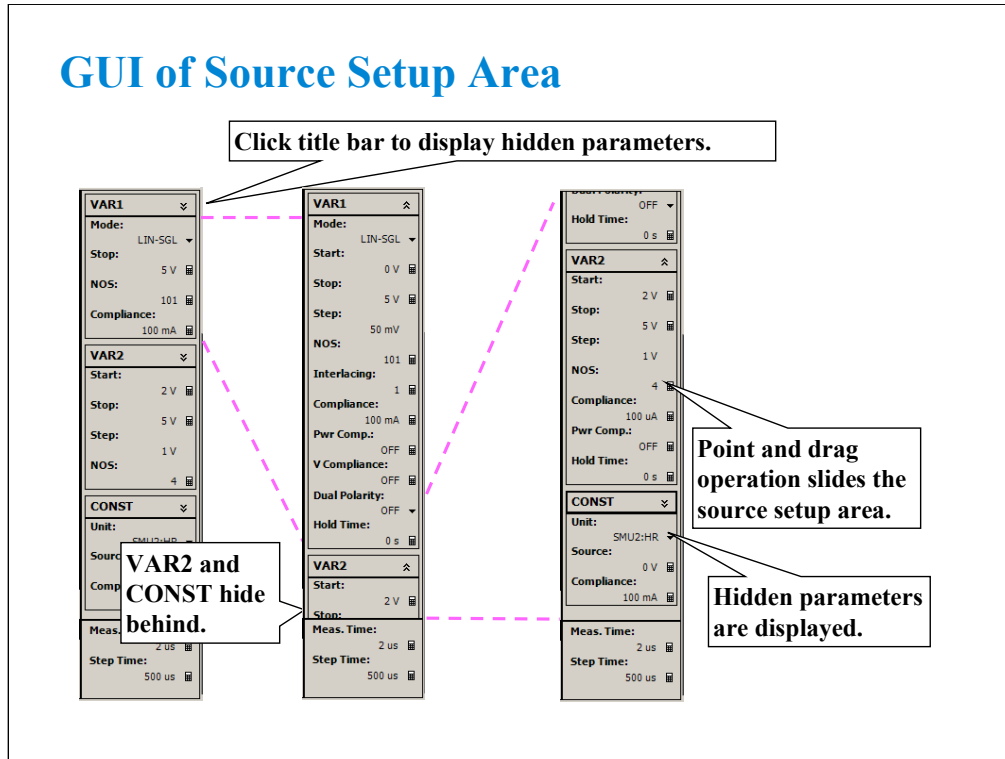

The source setup area is too small to display all setup parameter. So the source setup area provides two display mode, short and full. To switch the mode, click the title bar, VAR1, VAR2, or CONST. You can see the hidden setup parameters. Also use the point and drag operation to display the hidden parameters.

VAR1 Setup Parameters

The image shows the VAR1 setup menu with various parameters and their corresponding values. Annotations with arrows point to specific parameters and their definitions. To the right, a pulse waveform diagram illustrates the timing parameters: Pulse Base, Pulse Width, Pulse Delay, Meas. Delay, and Pulse Period. A blue dot on the waveform indicates the measurement point.

Parameter	Value
Mode	LIN-SGL
Start	0 V
Stop	5 V
Step	500 mV
NOS	11
Interlacing	10
Compliance	100 mA
Pwr Comp.	OFF
V Compliance	OFF
Pulse Base	0 V
Pulse Width	1 ms
Pulse Delay	0 s
Dual Polarity	OFF
Hold Time	0 s
Meas. Delay	AUTO
Meas. Time	2 us
Pulse Period	AUTO

Mode: LIN-SGL (linear single sweep)
LOG-SGL (log single sweep)
LIN-DBL (linear double sweep)
LOG-DBL (log double sweep)

NOS (numbers of steps)

Interlacing

Power Compliance

Voltage Compliance

Pulse Base

Pulse Width

Pulse Delay

Meas. Delay

Pulse Period

Baseline of Pulse Period

• : Measurement

In the short mode, the VAR1 setup area shows Mode, Stop, MOS, and Compliance only.

In the full mode, Start, Step, Interlacing, Pwr Comp., V Compliance, Dual Polarity, and Hold Time are added.

For the VPULSE/IPULSE source, Pulse Base, Pulse Width, Pulse Delay, and Meas. Delay are also added.

When a pulse source is set, Pulse Period is available instead of Step Time.

V Compliance is effective only for UHCU, UHVU, or HVMCU. This is the limit value for the voltage sweep output. The output voltage of the measurement resource is automatically measured, and the measured voltage is compared with this limit value. And then, if it exceeds the limit, the measurement status is set to the compliance status, and the sweep measurement stops. Voltage range and setting resolution depend on the measurement resource.

If Dual Polarity is set to ON, the VAR1 channel performs positive sweep from start to stop and negative sweep from -start to -stop in this order. For the pulsed negative sweep, the pulse base value is $-1 * (\text{Pulse Base})$.

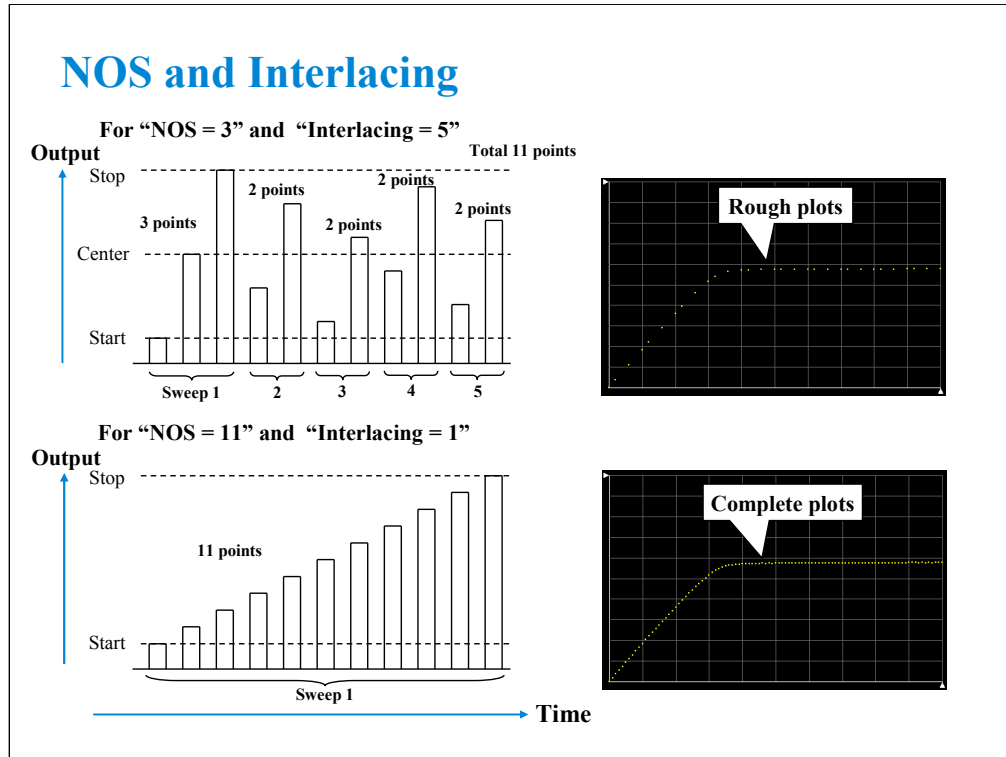

This slide explains the effect of the Interlacing parameter. The NOS parameter sets the number of steps in a sweep operation. And the Interlacing parameter sets the number of sweep operations performed in a single measurement.

This is the example of NOS=3 and Interlacing=5. At first, the sweep measurement is performed for the Start, Center, and Stop values. After that, the sweep measurement is repeated four times to narrow the sweep step. This results the same sweep steps as the sweep output of NOS=11 and Interlacing=1 although the timing is not same for some steps. By using the Interlacing, you can see the rough characteristics in the early stages. This is effective for the measurement such as the total pulsed sweep time is so long.

For NOS=N and Interlacing=M, the sweep is repeated M times so that the final sweep step is equal to Step/M. Total number of steps will be $N+(N-1)*(M-1)$.

The Interlacing is the function only for the Tracer Test environment. This function is not available for the other test environment. Also this function is not covered by the FLEX command set.

Pwr Comp. – Power Compliance

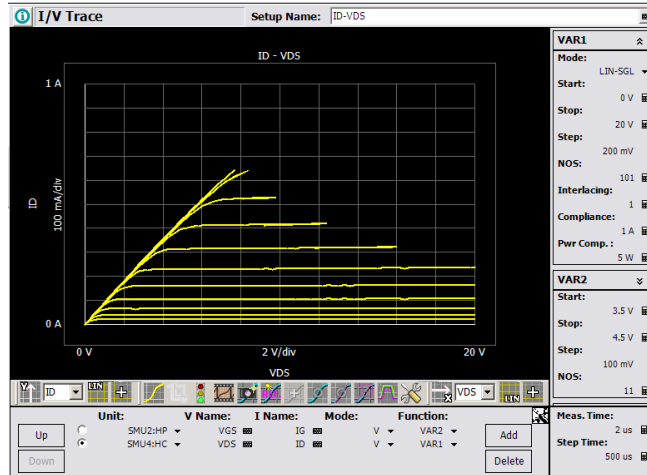

Power compliance is effective to limit power consumption in the device.

To Control Switching Matrix

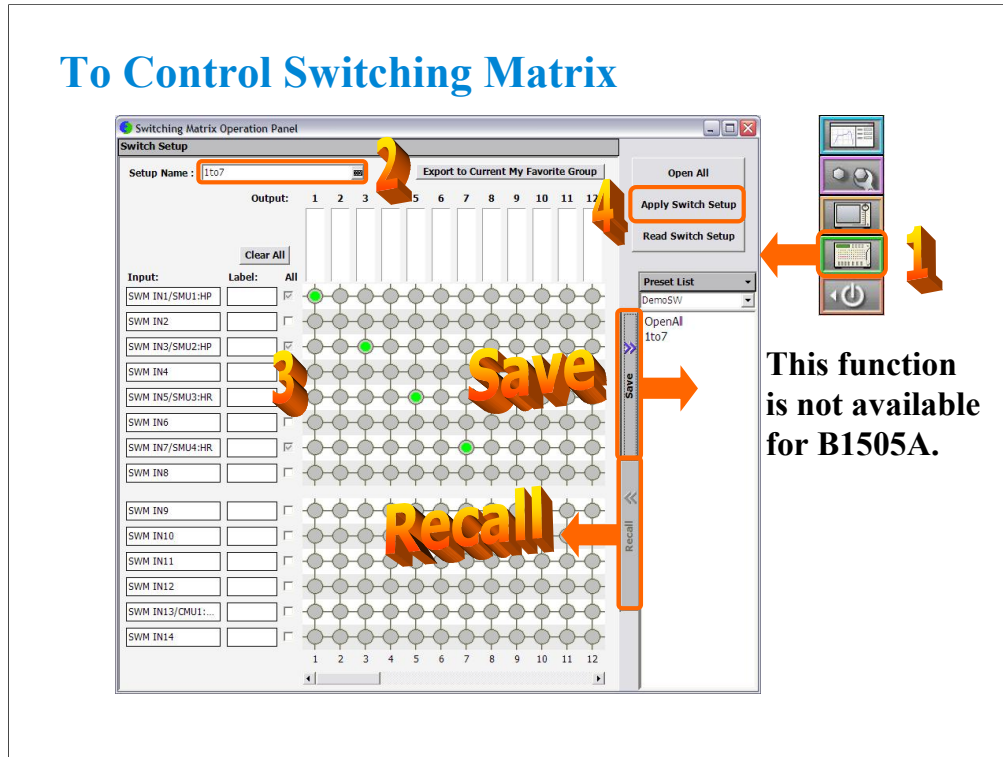

Step 1: Click Switching Matrix button to open the Switching Matrix Operation Panel.

Step 2: Enter the switch setup name.

Step 3: Define the switch setup by using the matrix on the operation panel window. Label can be set to input ports and output channels.

Step 4: Click the Apply Switch Setup button to send the switch setup to the B2200/E5250 switching matrix.

Note: Before clicking this button, connect the B2200/E5250 to the B1500A via GPIB, and set the configuration. To set the configuration, see Module 8.

The switch setups you create or modify MUST be saved in a preset group.

To save the setup, click the Save button.

To recall the setup, click the Recall button.

You can organize the setups by using the Preset List button.

To select the available preset group, use the field below the Preset List button. In the above example, the DemoSW group is selected and listed in the Preset List list.

To rename, duplicate, or delete the setups, and to add, rename, duplicate, or delete the preset group, use the function of the Preset List button menu or the Organize Preset Group dialog box shown in the next page.

Read Switch Setup: Read switch setup from B2200/E5250 via GP-IB and show it on the operation panel window.

Note: Standard revision of EasyEXPERT cannot support the E5250. The E5250 control is optional function of B1540A-002/B1541A-002.

Note: EasyEXPERT supports the E5250A installed with the E5252A matrix card.

To organize preset group for switch setup

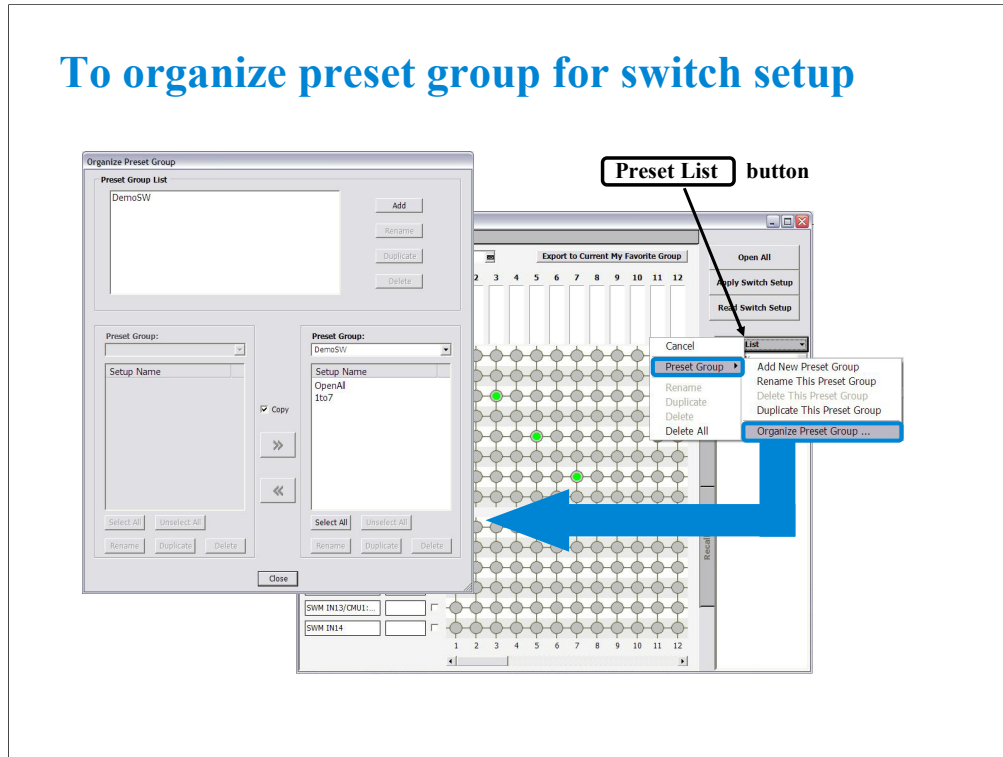

This dialog box is opened by selecting the Organize Preset Group function of the Preset List button menu, and is used to organize the switch preset group.

- Preset Group List

Lists the preset groups saved in the workspace. The Add, Rename, Duplicate, and Delete buttons are available to organize the preset groups.

- Copy

Sets the operation of the >>> button and the <<< button. They work as Copy when this check box is checked, and as Move when this check box is blank.

- >>>

Copies or moves the preset setup selected in the left Preset Group box to the right Preset Group box.

- <<<

Copies or moves the preset setup selected in the right Preset Group box to the left Preset Group box.

- Close

Closes the Organize Preset Group dialog box.

- Preset Group

Lists the preset setups saved in the preset group. The Select All, Unselect All, Rename, Duplicate, and Delete buttons are available to select or organize the setups saved in the preset group.

To add switch setup to test preset group

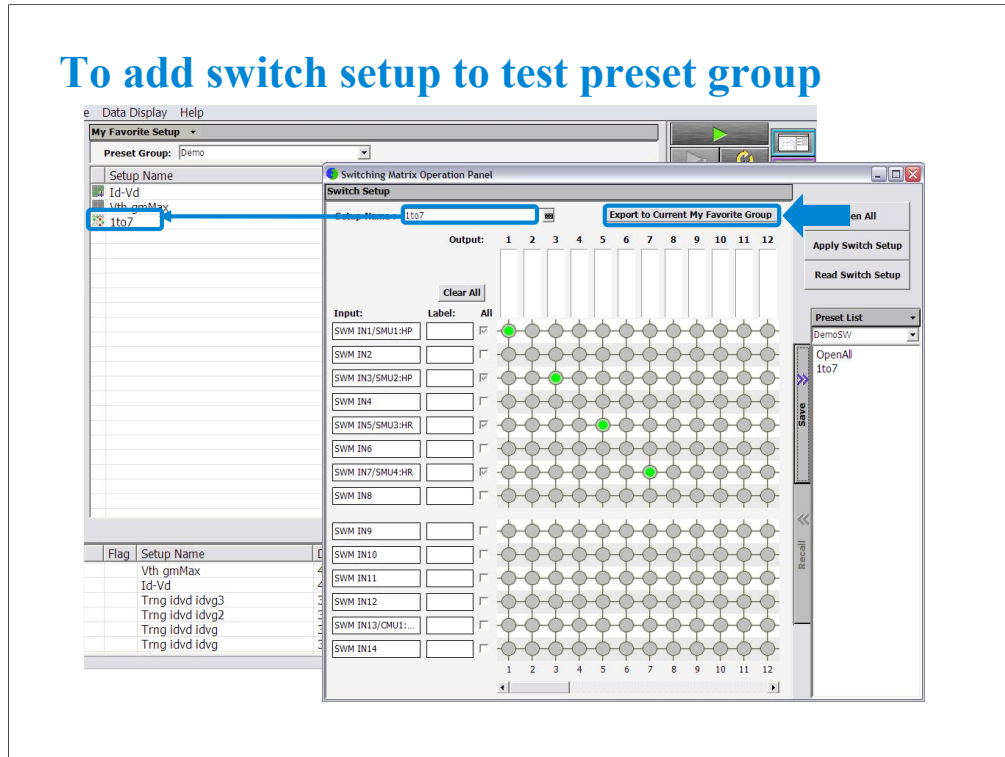

Switch setups can be saved in the preset group for test setups.

Click the Export to Current My Favorite Group button. The switch setup will be converted to a classic test setup and saved in the My Favorite Setup group opened in the main screen.

To select the available preset group, use the Preset Group field. In the above example, the Demo group is selected and listed in the quick test setup list.

To duplicate, import, or export the preset group, use the function of the My Favorite Setup banner menu or the Organize Preset Group dialog box shown in the next page.

Class Exercise

Add switch setup to test preset group.

- 1. Create a switch setup.**
- 2. Create your switch preset group, and save your setup.**
- 3. Add the switch setup to your test preset group.**
- 4. Save your test preset group.**

Note:

To Manage Data Display Window

Data Display > Default Data Display Properties...

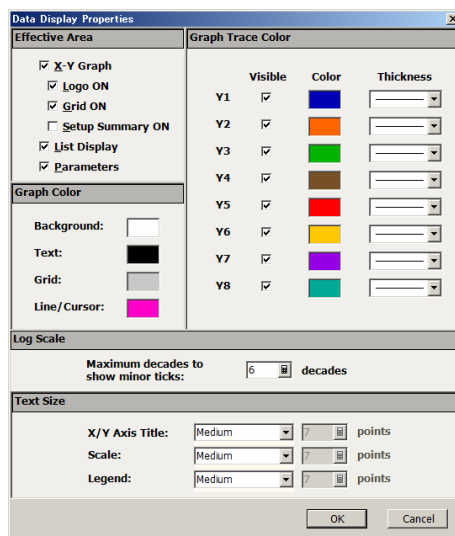

The Data Display Properties window is used to set the default setting of the Data Display window. This window is opened by selecting the Data Display > Default Data Display Properties... menu of the main screen.

The Effective Area is used to select the area effective when the Data Display window is opened, and provides the following check box.

- X-Y Graph: Enables the X-Y Graph area.
- Logo ON: Displays the Agilent logo at the upper left on the X-Y Graph.
- Grid ON: Displays the grid in the X-Y Graph.
- Setup Summary ON: Displays the channel setup summary information of the I/V Sweep or Multi Channel I/V Sweep Classic Test at the bottom of the area.
- List Display: Enables the List Display area.
- Parameters: Enables the Parameters area.

The Graph Color area is used to set the color map for the Data Display window. You can change the color of the background, text, graph grid, and line. The color palette is opened by clicking the pattern of the item.

The Graph Trace Color area is used to set visibility, color, and thickness of the data traces Y1 to Y8 plotted on the graph.

The Log Scale area is used to set the maximum number of decades to show the minor ticks for the log axis. If the number of graph decades is less than or equal to the entered value, the minor ticks are displayed. If it is greater than the entered value, the minor ticks are not displayed.

The Text Size area is used to set the font size for the graph. The available settings are Largest, Large, Medium, Small, Smallest, and Fixed. For settings other than Fixed, the appropriate size is automatically selected. For Fixed, a font size entry field is provided, and the specified font size is always applied.

- X/Y Axis Title: Font size for the axis title
- Scale: Font size for the X and Y coordinate values
- Legend: Font size for the graph legend

To Manage Data Display Window

Data Display > Manage Data Display...

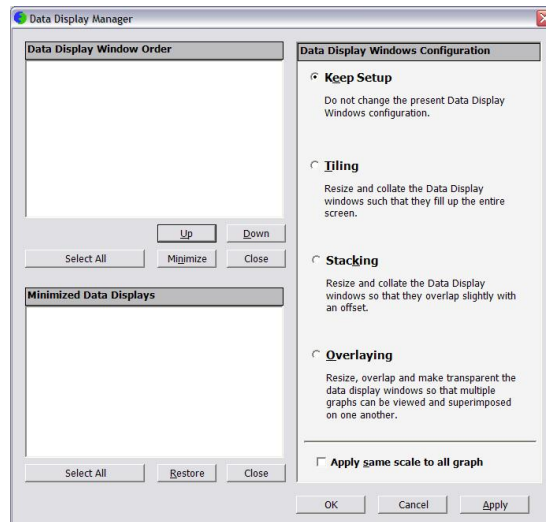

The Data Display Manager is used to control the appearances of the Data Display windows. This window is opened by selecting the Data Display > Manage Data Display... menu of the main screen. The Data Display Window Order area lists the Setup Name of the Data Display windows opened. The list items from top to bottom correspond to the windows from front to back in the screen image. The Minimized Data Displays area lists the Setup Name of the Data Display windows minimized. The Data Display Window Configuration area provides the following radio buttons and a check box to change the appearances of the Data Display windows. All functions are available for the opened windows. See following slides for the display examples.

- Keep Setup: Keeps the present configuration of the Data Display windows.
- Tiling: Resize and collate the data display windows such that they fill up the entire screen.
- Stacking: Resize and collate the data display windows so that they overlap slightly with an offset.
- Overlaying: Resize, overlap, and make transparent the data display windows so that multiple graphs can be viewed and superimposed on one another.

The following check box must be checked to apply the same graph scale to all graphs.

- Apply same scale to all graph

Tiling

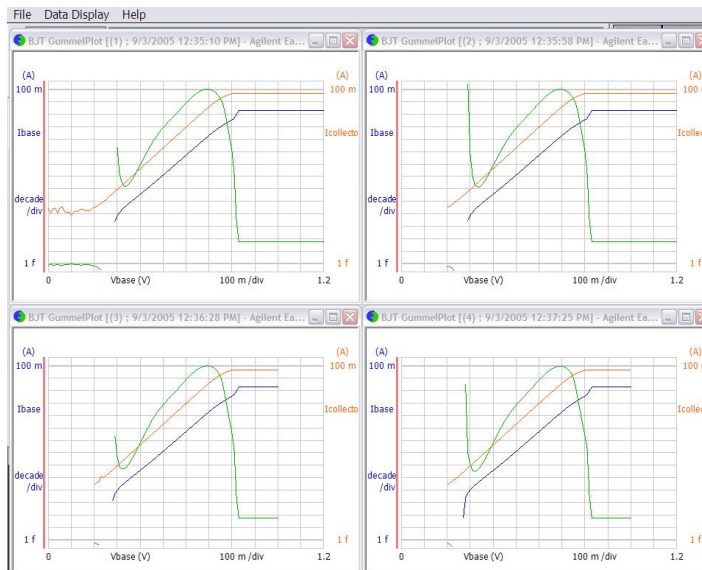

This is a display example of Tiling.

Stacking

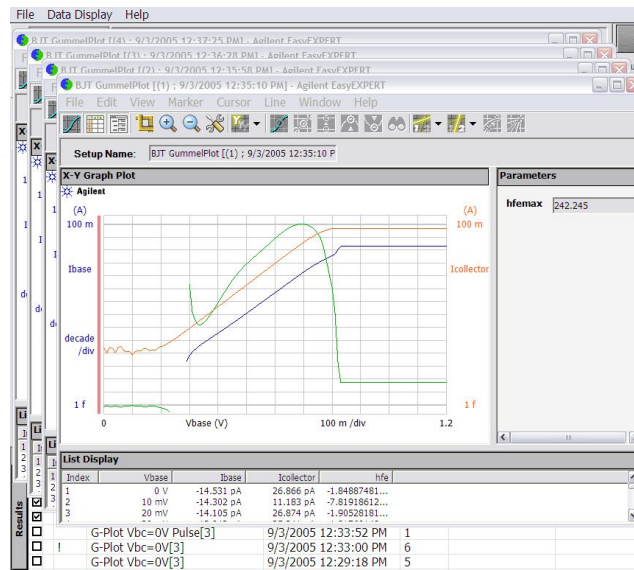

This is a display example of Stacking.

Overlaying

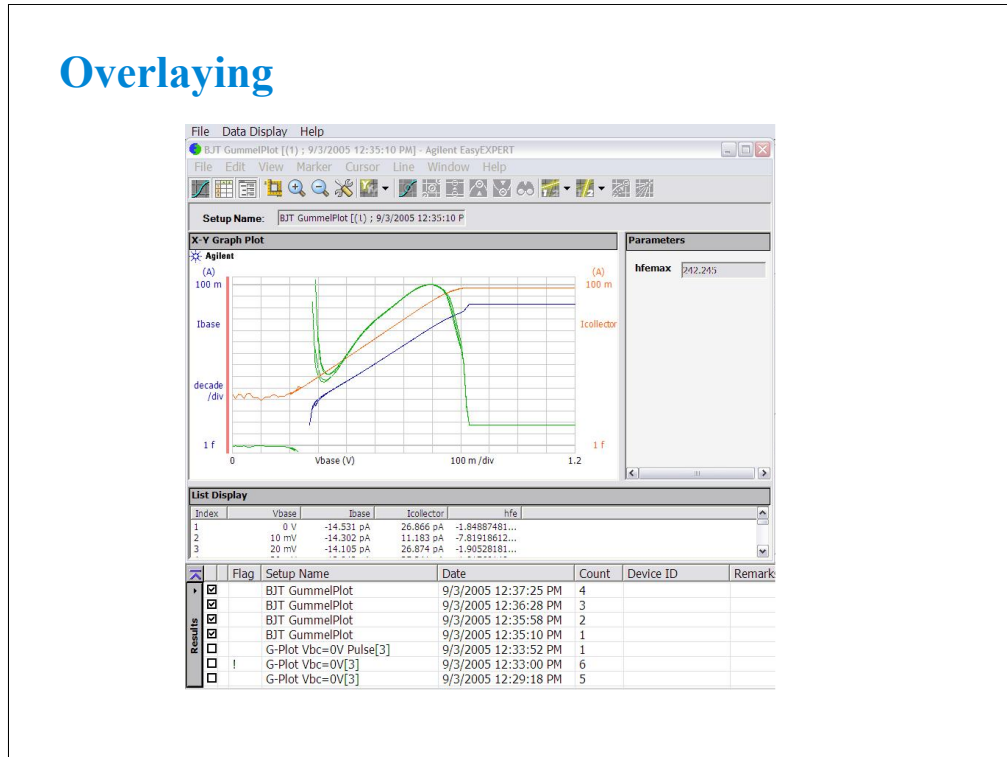

This is a display example of Overlaying.

To file/stack/overlay windows



When some Data Display windows are opened, the following Windows menu functions are useful.

Tiling

Tiles all Data Display windows on the screen.

Stacking

Stacks all Data Display windows on the screen.

Overlaying

Overlays all Data Display windows on the screen. Then the position, window size, and visibility of the most front window are applied to all windows on the screen.

The background of the X-Y Graph area is cleared except for the most back window.



2

Data Display and Management



In This Module

- **Data Display window**
- **Graph Analysis Tools**
- **Data Status**
- **To Change Graph/List/Display Setup**
- **To See Print Preview**
- **To Print Display Data**
- **To Copy Graph Plot/List Data**
- **To Save Analysis Result**
- **To Use Preview Window**

This section describes the above topics. You will understand how to use analysis tools, how to change display setup, and how to print/export test result data.

Data Display window

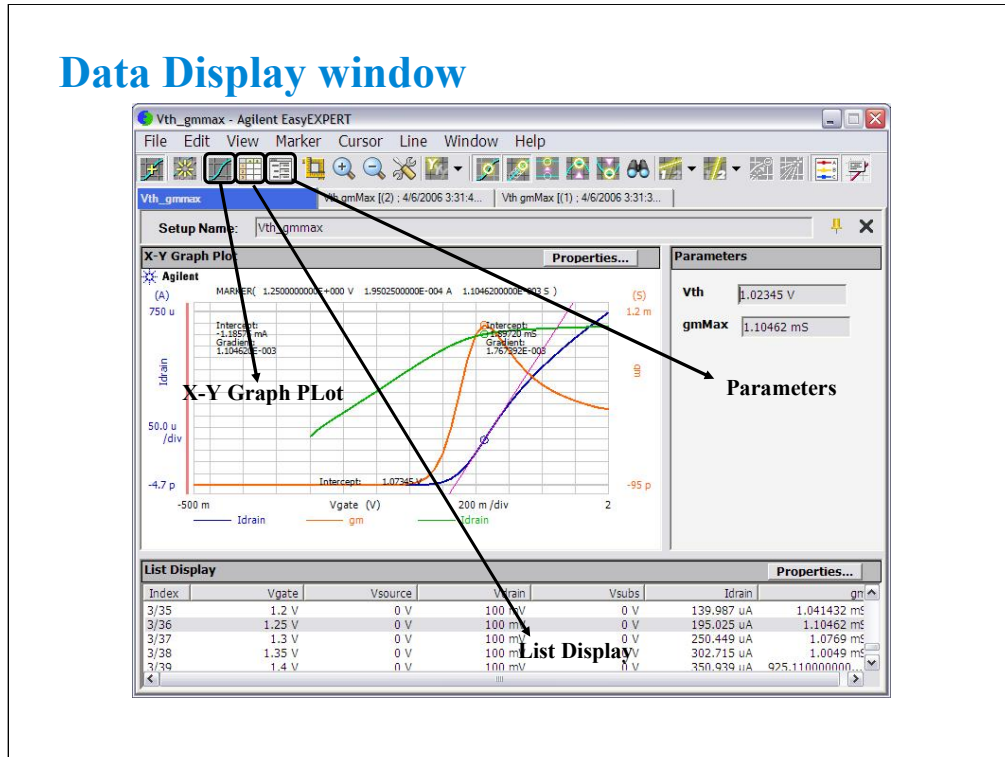

The Data Display window is opened after measurement automatically, or by clicking the Data Display button. And the window is used to display measurement data and analyze the data.

The Show X-Y Graph icon displays/hides the X-Y Graph Plot area. This is the same as the View > X-Y Graph menu.

The Show List Display icon displays/hides the List Display area. This is the same as the View > List Display menu.

The Show Parameters icon displays/hides the Parameters area. This is the same as the View > Parameters menu.

Multiple data display windows can be opened while the Multi Display indicator is ON. Then the test result data of the same test setup name will

be displayed on the exclusive Data Display window and the test result data of the different test setup name will be displayed on the new Data Display window. To set Multi Display ON, click the Run Option button located at the top right of the Main window, check the "Allocate Data Display for each test" box on the Run Option dialog box, and click the Close button.

Graph Analysis Tools

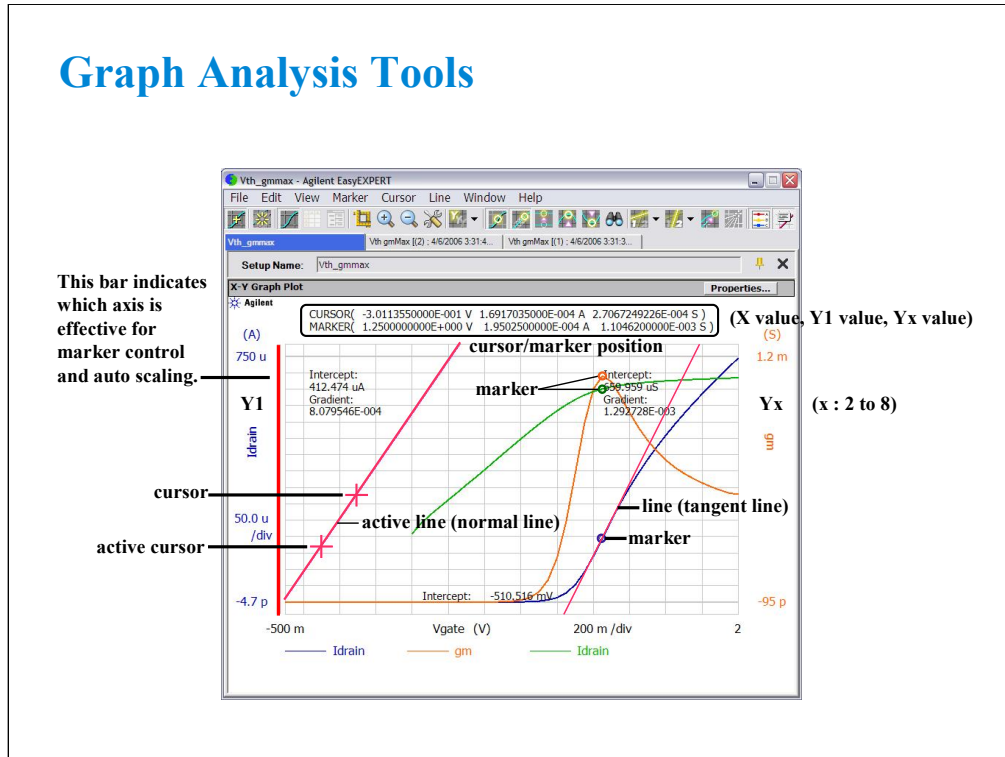

The Data Display window provides marker, cursors, and lines for analyzing test result data. Marker is used to read measurement data and draw a tangent line. Cursors are used to read the cursor position and draw a normal line, gradient line, or regression line. The cursor/marker position data is displayed top of the graph plot area.

Clicking Y axis can select the Y axis effective for the analysis tools. On the graph, left axis is always Y1 axis. And the right axis is selectable from Y2 to Y8 axes.

Graph Analysis Tools

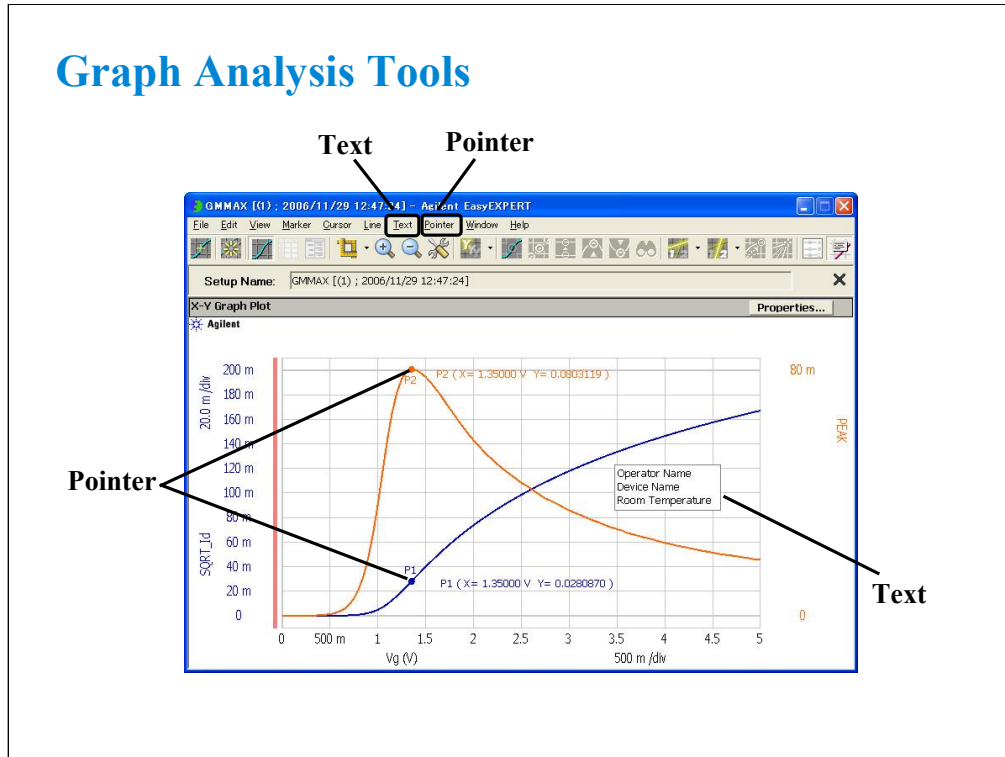

Text and pointer are the tools to decorate the X-Y Graph.

The text is used to leave notes on the graph. The notes will be measurement conditions, device information, operator name, and so on. Up to 20 texts can be added to a graph.

The pointer is used to indicate the remarkable measurement point and show the X and Y coordinates like the marker. The new pointer can be displayed on the marker point at first and can be moved on the measurement data curve by using the rotary knob or the mouse wheel. Up to 30 pointers can be added to a graph.

Graph Analysis Tools

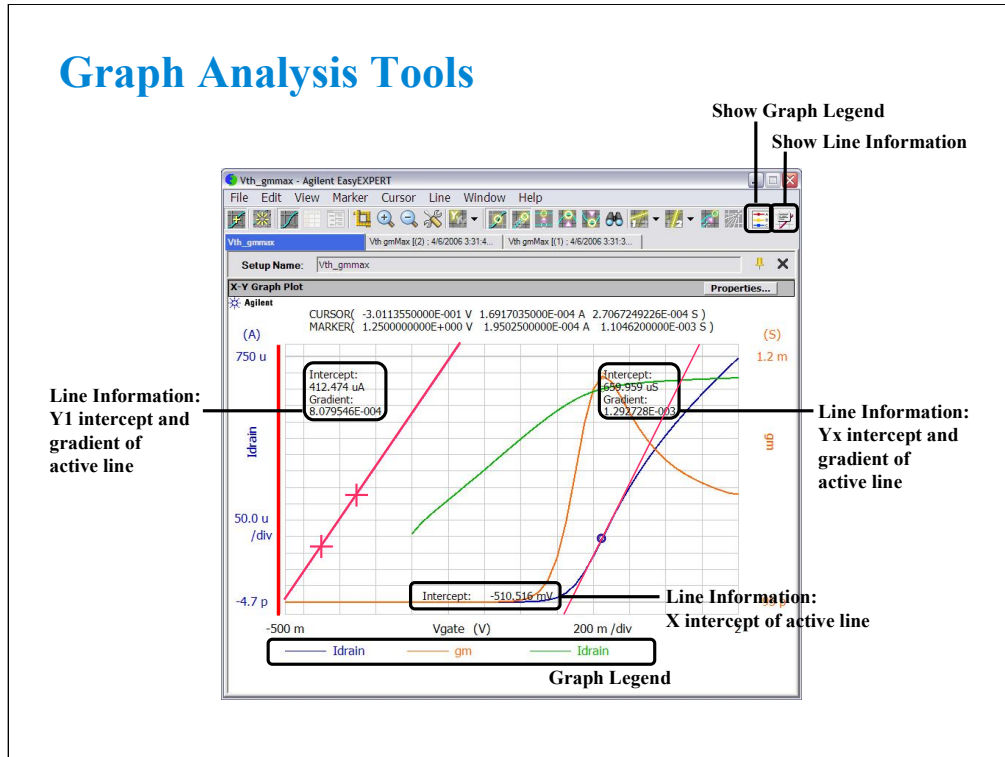

When a line is displayed, the line information can be displayed in the graph plot area.

The Show Line Information icon displays/hides the line information. This is the same as the View > Line Information ON/OFF menu.

The Show Graph Legend icon displays/hides the graph legend. This is the same as the View > Graph Legend ON/OFF menu.

Graph Analysis Tools

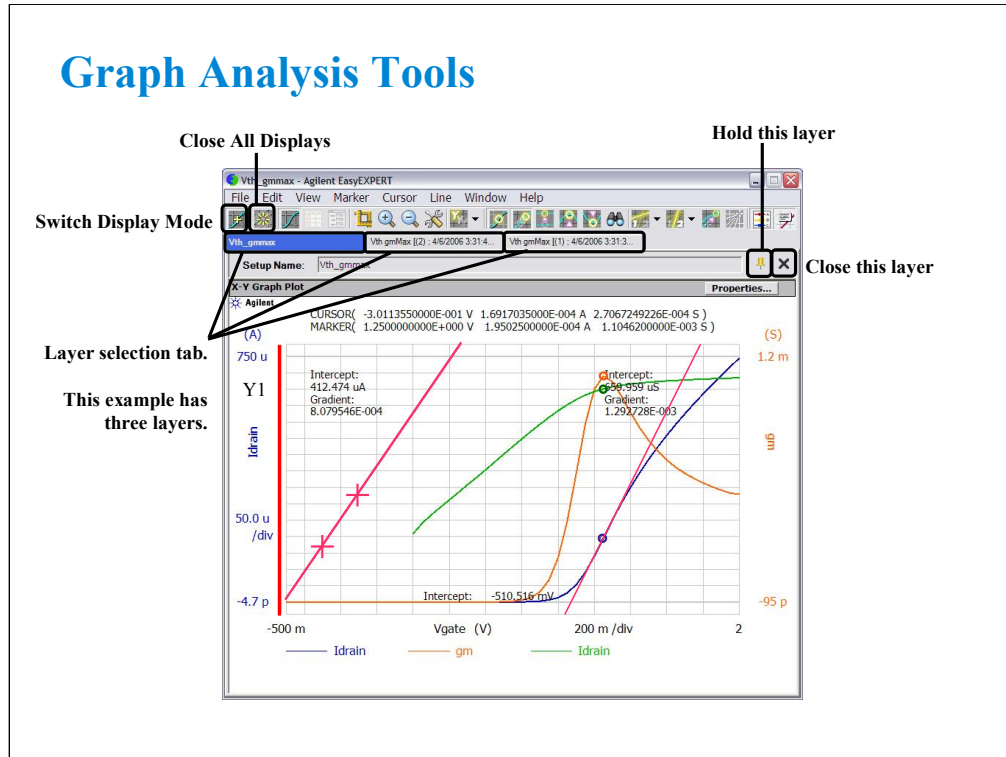

If the append measurement is performed, the data display layer is added to the Data Display window. In this example, the Data Display window has three layers.

Use the icons shown above to organize the data display layers.

Switch Display Mode icon switches the mode, overwrite or append.

In the overwrite mode, the data is displayed in a new Data Display window.

In the append mode, the data is displayed on a new display layer in the present Data Display window.

The Data Display window can hold up to 10 display layers. And the earliest layer over 10 will be automatically deleted. The Hold this layer icon is available when the window holds at least two layers. If this icon shows the standing pin, the layer will be held. If this icon shows the laid pin, the layer can be deleted. Double clicking the tab gives the same result as this icon.

Graph Analysis Tools

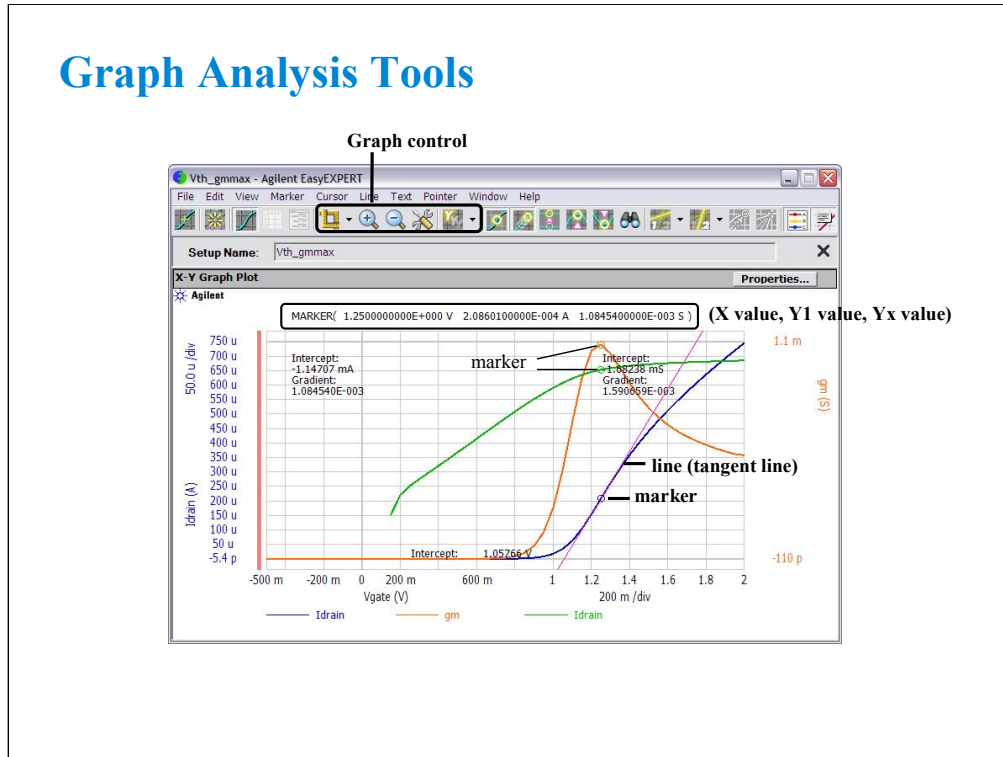

Graph control:

Auto Scale icon will change the graph scale automatically to fit the trace in the graph. The right arrow button opens the menu for enabling or disabling the run time auto scaling. This function is set independently for the X and Y axes. If this function is enabled, the graph scale will be changed automatically to fit the trace in the graph during the measurement.

Zoom In icon zooms the data graph in. This enlarges the trace in the graph. Then the center of zooming will be the cursor position.

Zoom Out icon zooms the data graph out. This reduces the trace in the graph.

Graph Setup icon opens the Graph Setup dialog box used to change the graph axis setup.

Choose Active Y axis icon selects the Y axis that is effective for the analysis tools (marker control and auto scaling).

If multiple layers are opened on the Data Display window, the scale change is applied to the layers. This means that the X-Y graph scale will be shared by all display layers. The auto scaling is performed as follows.

1. Graph scale is optimized for the data on the selected layer (top layer).
2. The graph scale is applied to the graph in the all layers.

Note that auto scaling is performed independently for the left and right Y axes.

There is also a function for resetting the graph scale. Click View > Cancel Scaling > This Display or All Displays.

This Display will reset the selected layer only. All Displays will reset all display layers.

Graph Analysis Tools

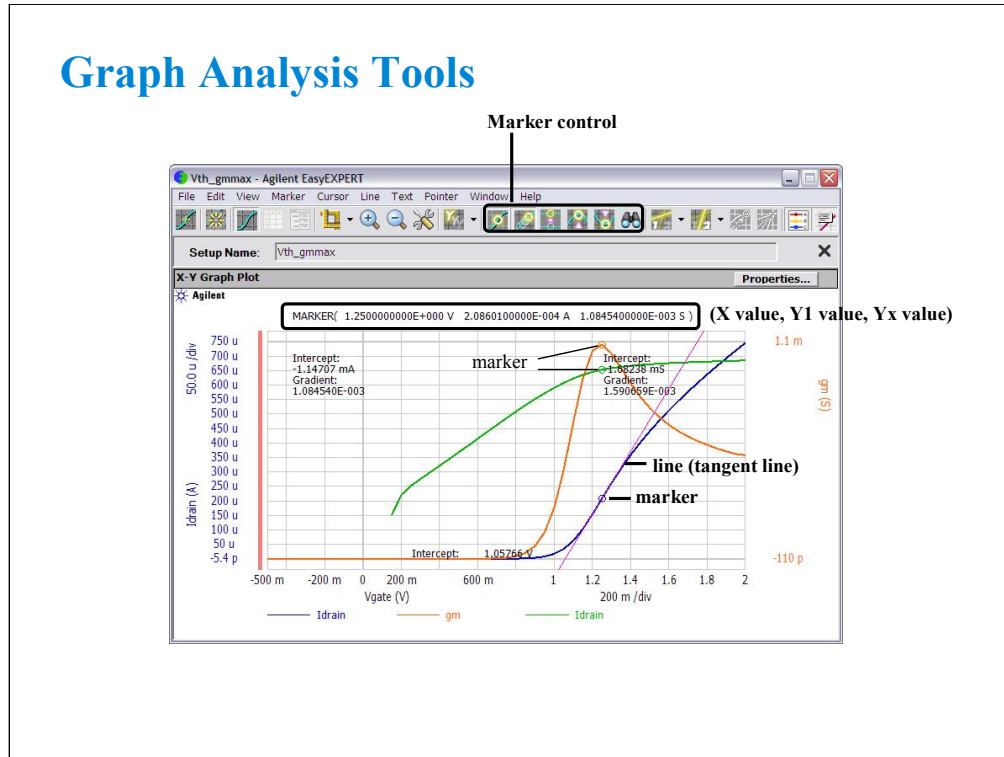

Marker control:

Marker ON/OFF icon enables or disables the marker.

Interpolation ON/OFF icon enables or disables the interpolation function of measurement data. You can read the interpolation data between two actual measurement points.

Marker Skip icon moves the marker to the next measurement curve that is added by the VAR2 variable.

Marker Maximum icon moves the marker to the maximum measurement point.

Marker Minimum icon moves the marker to the minimum measurement point.

Marker Search icon opens the Direct Marker/Cursor dialog box used to specify the coordinate values to move the marker.

Graph Analysis Tools

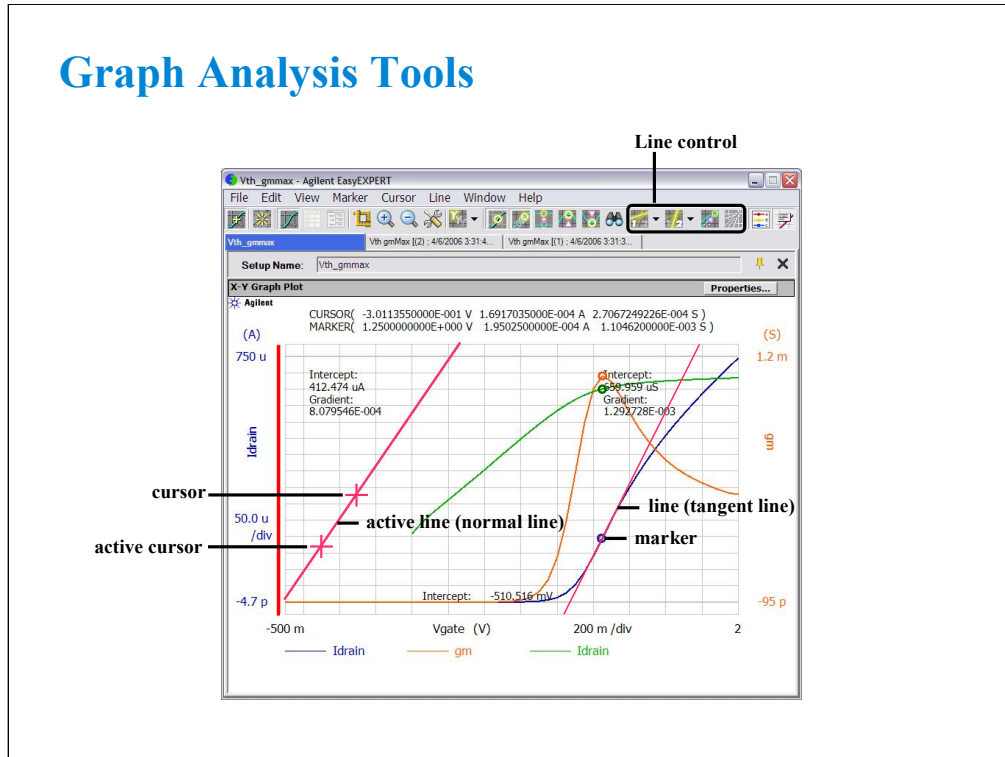

Line control:

Line 1 State icon enables or disables line 1 and its function: normal, gradient, tangent, or regression.

Line 2 State icon enables or disables line 2 and its function: normal, gradient, tangent, or regression.

Cursor to Marker icon moves the cursor to the marker position.

Adjust Gradient icon is available when a gradient line is active. Clicking this icon enables the rotary knob and the mouse wheel to increase/decrease the gradient of the line. Clicking this icon again, clicking the rotary knob, or clicking the mouse wheel disables this function.

To Enable Marker and Line

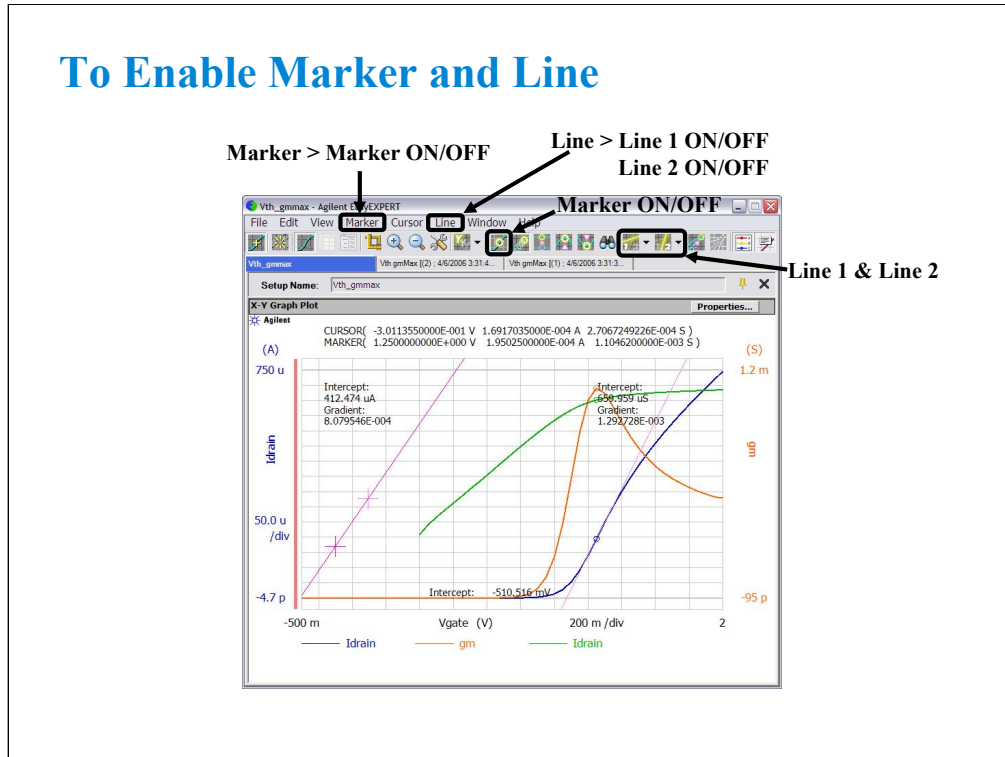

To enable maker, click the Marker ON/OFF icon, or select the Marker > Marker ON/OFF menu.

To enable the Line 1, click Line 1 icon and select one of the line mode. Or select the Line > Line 1 ON/OFF menu and select one of the line mode.

To enable the Line 2, click Line 2 icon and select one of the line mode. Or select the Line > Line 2 ON/OFF menu and select one of the line mode.

If you enable the Normal line, two cursors are available. The cursors specify the points that the line passes through.

If you enable the Gradient line, a cursor is available. The cursor specifies the point that the line passes through.

If you enable the Regression line, two cursors are available. The cursor specify the measured data used to draw the regression line.

To Draw Normal Line

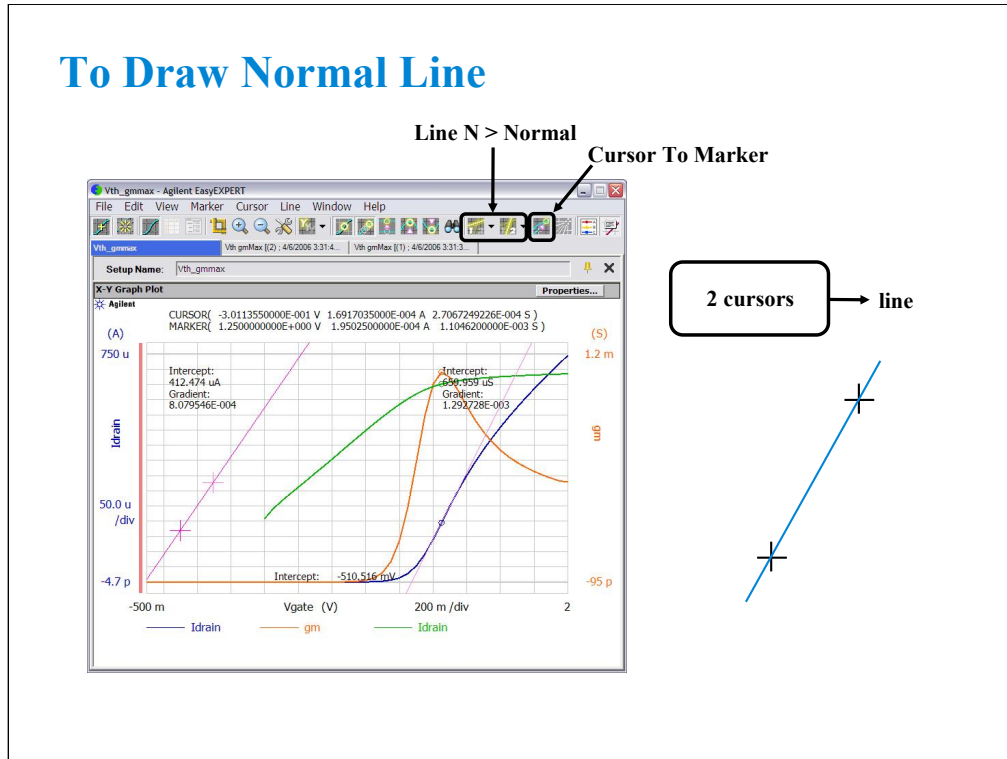

Enable the Normal line by clicking the Line 1 (or Line 2) icon and Normal.

Move cursors to draw the line. The line passes through the cursor points.

To move the cursor, you can use the Cursor To Marker icon. The cursor will move to the marker point.

To Draw Gradient Line

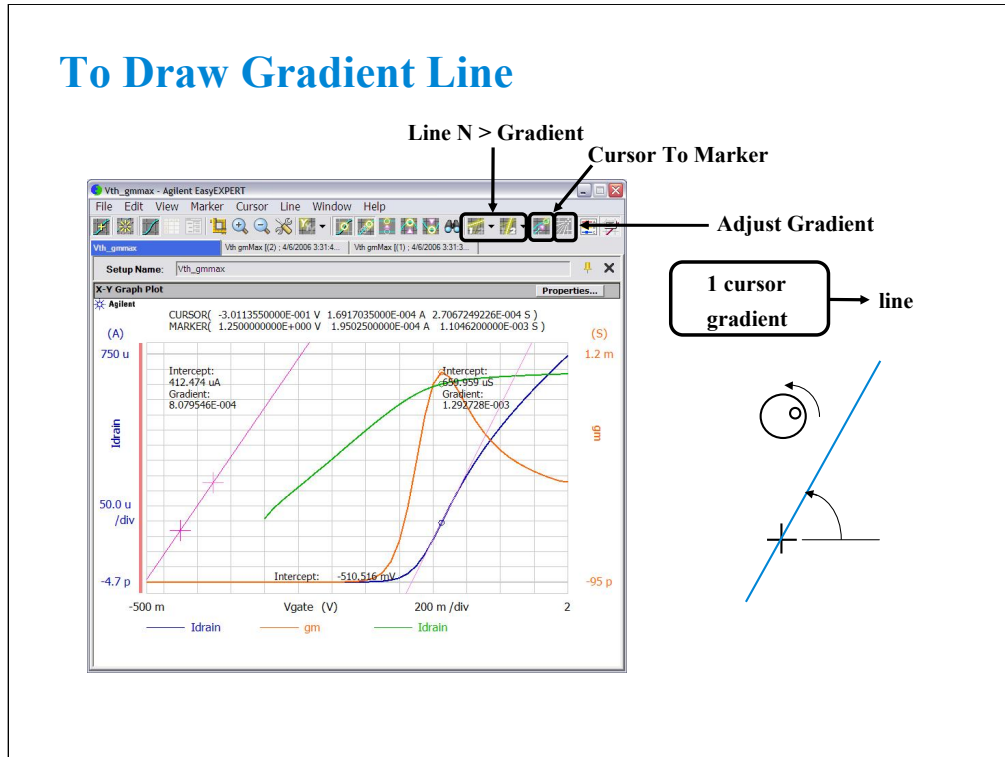

Enable the Gradient line by clicking the Line 1 (or Line 2) icon and Gradient.

Move the cursor to specify the point that the line passes through. And click the Adjust Gradient icon.

Use the rotary knob or the mouse scroll button to adjust the gradient of the line.

To move the cursor, you can use the Cursor to Marker icon. The cursor will move to the marker point.

To Set Gradient Value

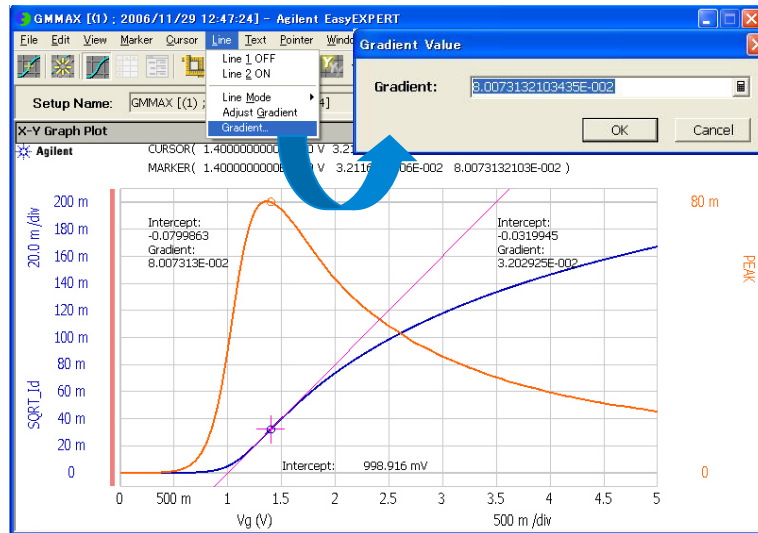

This is another way to draw the gradient line.

Set the line 1 or 2 ON and select the gradient line mode. Then click Line > Gradient... to open the Gradient Value dialog box.

On the dialog box, enter the desired gradient value, and click OK to draw the gradient line.

To Draw Tangent Line

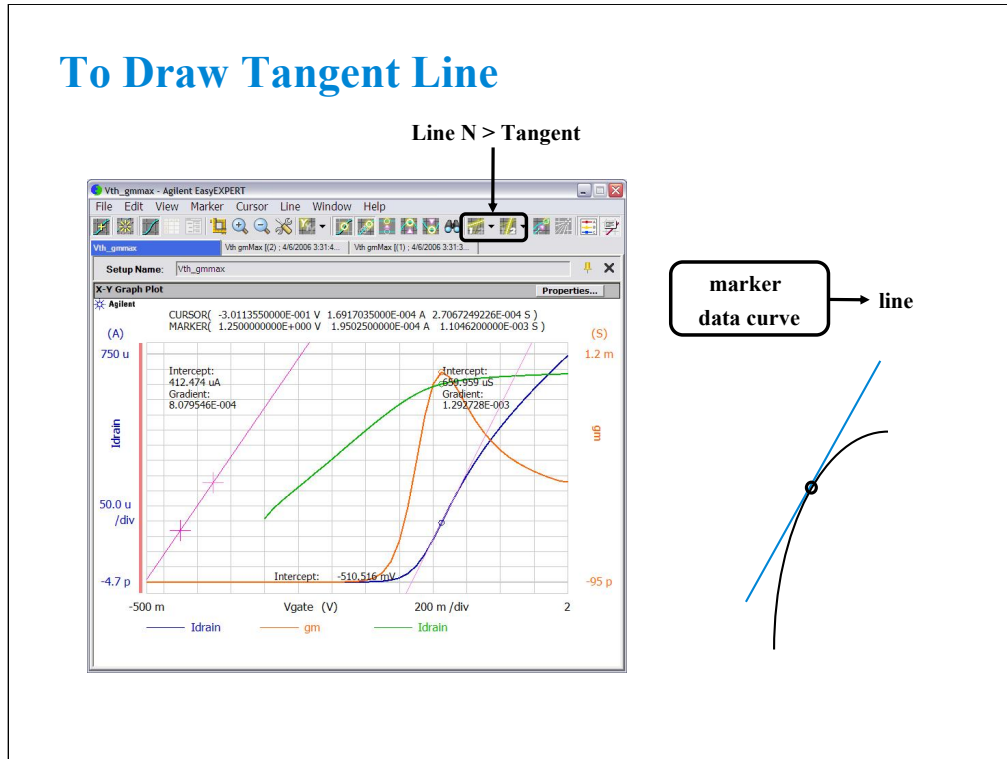

Enable the Tangent line by clicking the Line 1 (or Line 2) icon and Tangent.

Move marker to draw the line. The tangent line will pass through the marker point.

To Draw Regression Line

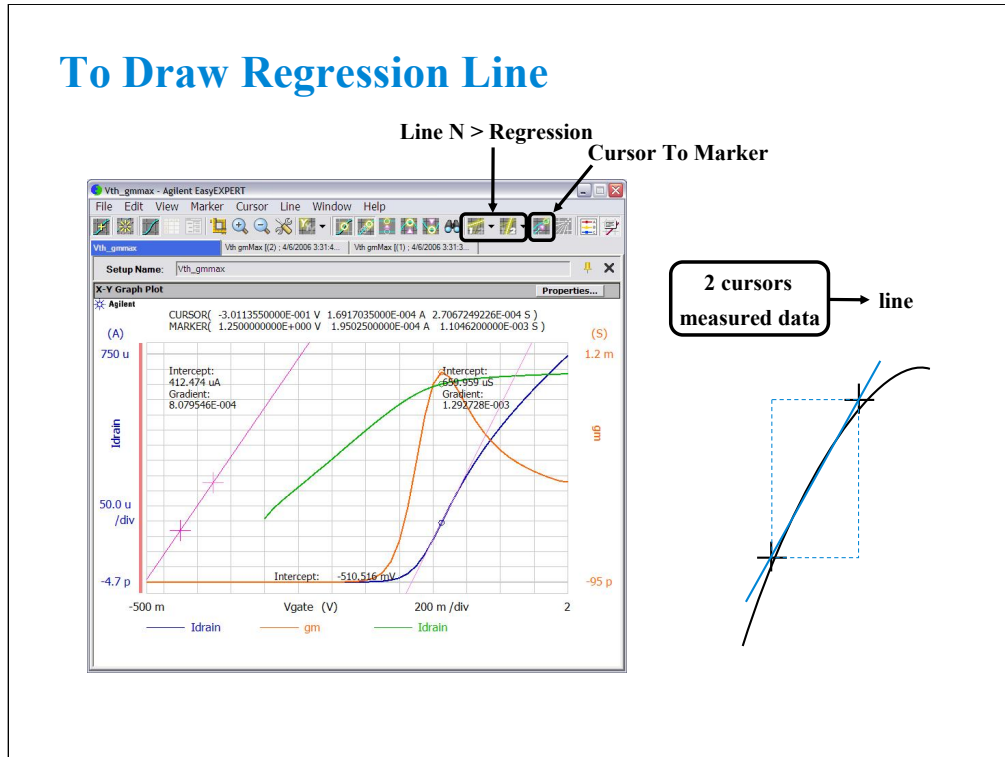

Enable the Regression line by clicking the Line 1 (or Line 2) icon and Regression.

Move cursors to specify the region of the measurement data used for the regression calculation.

To move the cursor, you can use the Cursor To Marker icon. The cursor will move to the marker point.

To Fix a Line

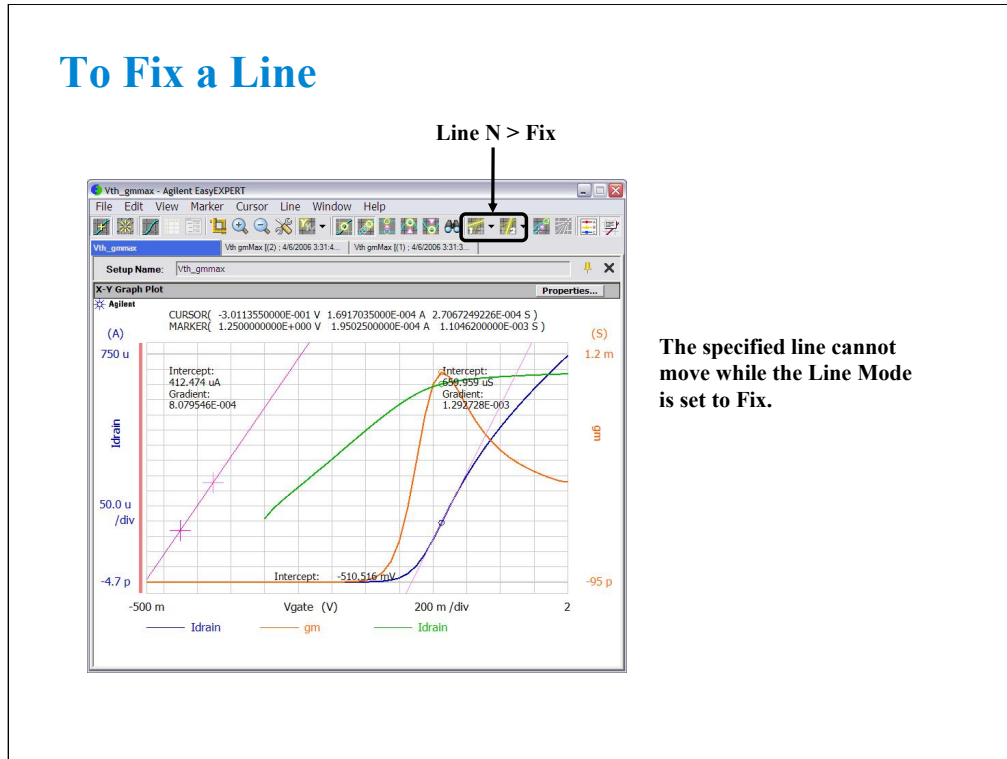

To fix a line, click the Line 1 (or Line 2) icon and Fix, or select the Line > Line Mode > Fix menu. While the Line Mode is set to Fix, the specified line cannot move.

To Add Text

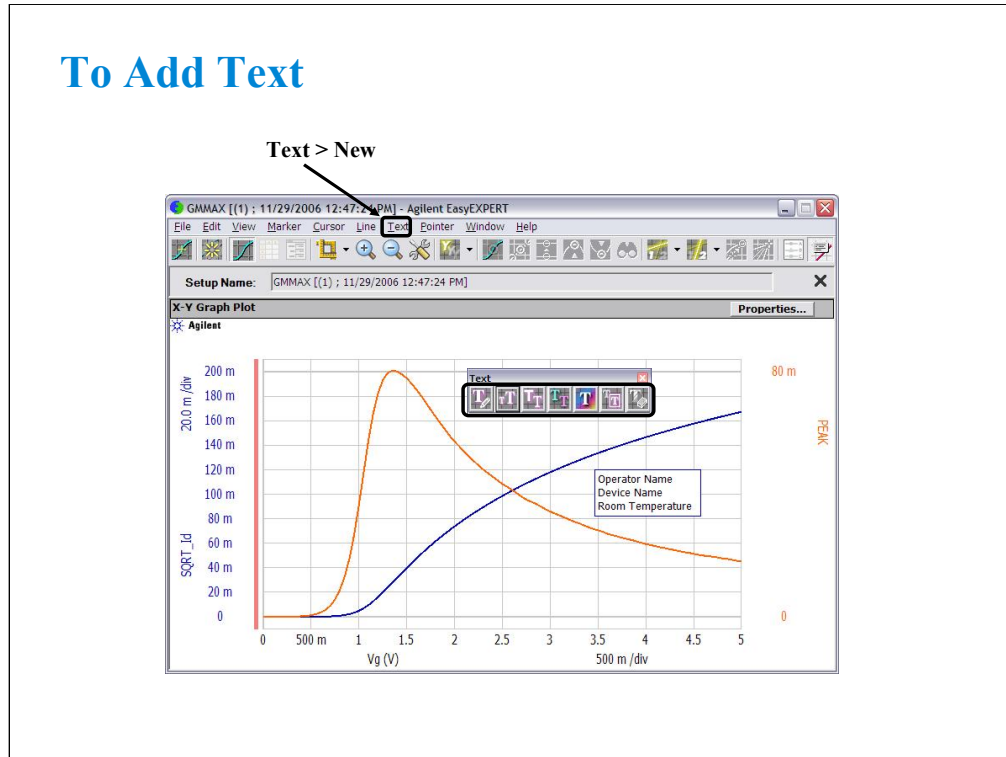

To add a text, click Text > New. A text editor appears. Then enter the text you desire.

The following functions are available for the selected text(s) via the Text menu, the Text icons, or the right-click menu.

Clicking on a text will select the text. To select the multiple texts, click the text while holding down the Shift key on the keyboard.

Edit Mode: Edits the selected text.

Size: Sets the font size of the selected text(s). The available setting values are Largest, Large, Medium, Small, Smallest, and Fixed Point (6, 7, 8, 9, 10, 11, 12, 14, 16, 18, or 20). For settings other than Fixed Point, an appropriate size will automatically be applied. For Fixed Point, the specified font size will always be applied.

Font: Sets the font of the selected text(s).

Text Color: Sets the text color of the selected text(s). Click Customize to open the color palette.

Background Color: Sets the background color of the selected text(s). Click Customize to open the color palette.

Hide Frame/Show Frame: Hides or shows the frame for the selected text(s).

Delete: Deletes the selected text(s).

Dragging a text moves this text.

To Add Pointers

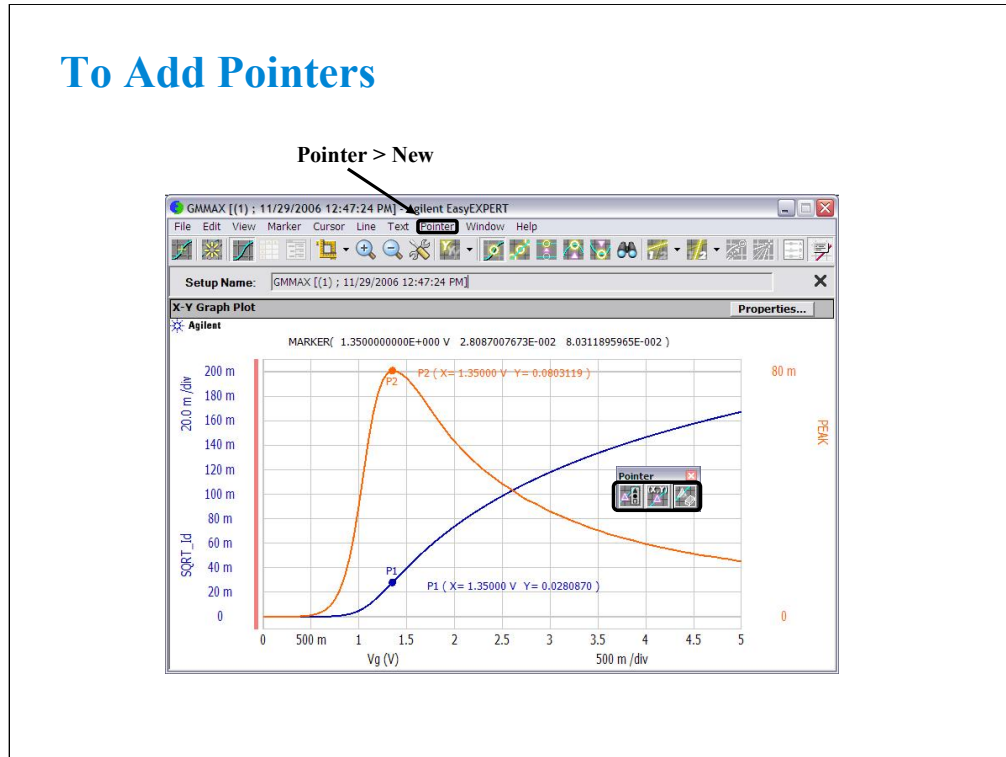

To add a pointer, set Marker ON, click Pointer > New. A pointer and description (pointer ID and X-Y coordinate values) appear. Then move the pointer you desire by using the rotary knob or the mouse wheel.

The following functions are available for the selected pointer(s) or description(s) via the Pointer menu, the Pointer icons, or the right-click menu.

Clicking on a pointer will select the pointer. To select the multiple pointers, click the pointer while holding down the Shift key on the keyboard.

Clicking on a description will select the description of a pointer. To select the multiple descriptions, click the description while holding down the Shift key on the keyboard.

Shape: Sets the shape of the selected pointer(s).

Hide Description/Show Description: Hides or shows the description of the selected pointer(s).

Delete: Deletes the selected pointer(s).

The rotary knob or the mouse wheel can be used to move the selected pointer in the VAR1 direction. The pointer can not be moved in the VAR2 direction.

Dragging a description of pointer moves this description of pointer.

Data Status

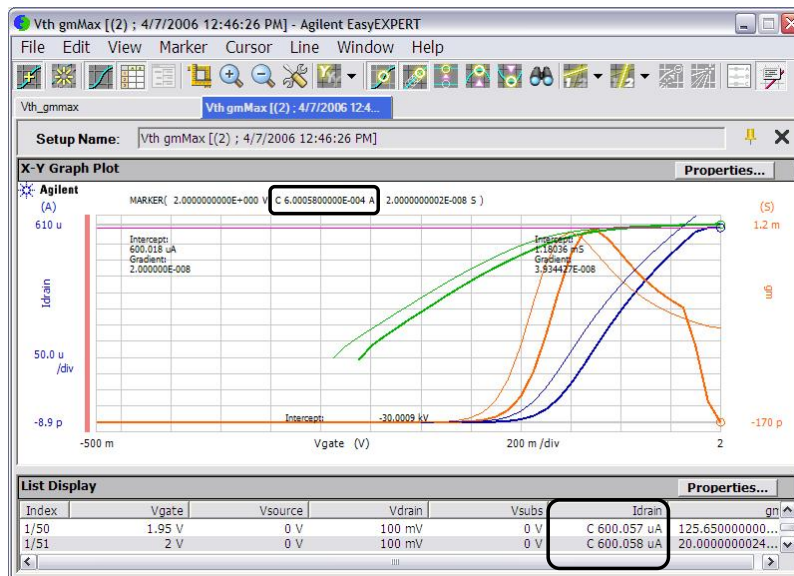

If measurement unit detects any status while measurement, the status code is recorded with the measurement data. In this example, a SMU detected the compliance condition in the drain channel, so the status code C is put just before the Idrain value.

SMU status code:

- C: Compliance
- T: Other channel compliance
- X: Oscillation
- V: Overflow

MFCMU status code:

- U: Unbalance
- D: I/V amp saturation
- V: Overflow

To Change Graph Properties

Visible	Color	Thickness
<input checked="" type="checkbox"/>	Blue	[Dropdown]
<input checked="" type="checkbox"/>	Orange	[Dropdown]
<input checked="" type="checkbox"/>	Green	[Dropdown]
<input checked="" type="checkbox"/>	Brown	[Dropdown]
<input checked="" type="checkbox"/>	Red	[Dropdown]
<input checked="" type="checkbox"/>	Yellow	[Dropdown]
<input checked="" type="checkbox"/>	Purple	[Dropdown]
<input checked="" type="checkbox"/>	Teal	[Dropdown]

The Graph Properties dialog box is used to set the following setting of the selected Data Display window. This dialog box is opened by clicking the Properties... button in the X-Y Graph Plot area or by selecting the Edit > Graph Properties... menu of the Data Display window.

The Logo ON check box is used to display the Agilent logo at the upper left on the X-Y Graph.

The Grid ON check box is used to display the grid in the X-Y Graph.

The Setup Summary ON check box is used to display the channel setup summary information of the I/V Sweep or Multi Channel I/V Sweep Classic Test at the bottom of the area.

The Graph Color area is used to set the color map for the Data Display window. You can change the color of the background, text, graph grid, and line/cursor. The color palette is opened by clicking the pattern of the item.

The Graph Trace Color area is used to set visibility, color, and thickness of the data traces Y1 to Y8 plotted on the graph.

The Log Scale area is used to set the maximum number of decades to show the minor ticks for the log axis. If the number of graph decades is less than or equal to the entered value, the minor ticks are displayed. If it is greater than the entered value, the minor ticks are not displayed.

The Text Size area is used to set the font size for the graph. The available settings are Largest, Large, Medium, Small, Smallest, and Fixed. For settings other than Fixed, the appropriate size is automatically selected. For Fixed, a font size entry field is provided, and the specified font size is always applied.

- X/Y Axis Title: Font size for the axis title
- Scale: Font size for the X and Y coordinate values
- Legend: Font size for the graph legend

Setup Summary

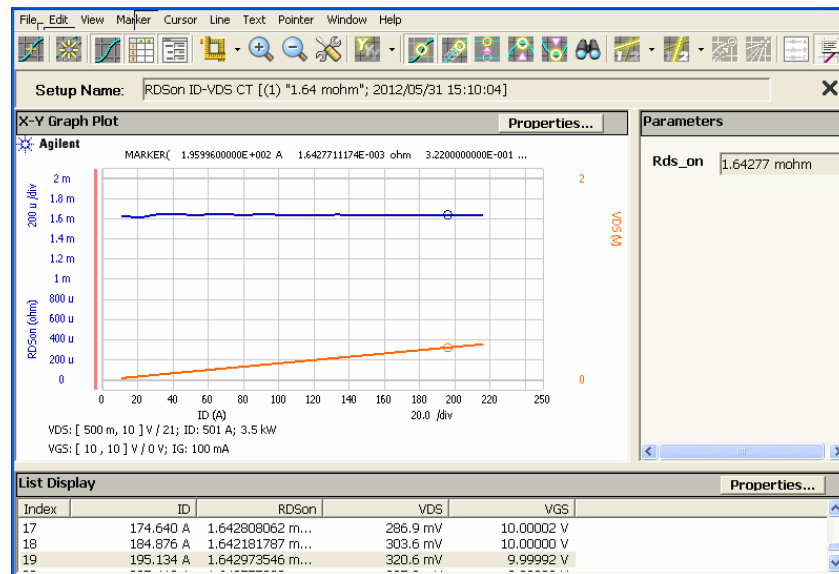

If the Setup Summary ON is checked, the channel setup summary information shown below is displayed at the bottom of the graph area.

The setup for one channel is displayed with one line as follows. Where, the items in {} are the setting values.

VAR1 Channel:

For the voltage output channel:

{V Name}: [{Start}, {Stop}] V / {No of Step}; {I Name}: {Compliance} A; {Pwr Comp} W

For the current output channel:

{I Name}: [{Start}, {Stop}] A / {No of Step}; {V Name}: {Compliance} V; {Pwr Comp} W

Example: VDS: [0, 10] V / 101; ID: 1 A; 1 W

VAR2 Channel:

For the voltage output channel:

{V Name}: [{Start}, {Stop}] V / {Step} V; {I Name}: {Compliance} A; {Pwr Comp} W

For the current output channel:

{I Name}: [{Start}, {Stop}] A / {Step} A; {V Name}: {Compliance} V; {Pwr Comp} W

Example: VGS: [0, 5] V / 1 V; ID: 1 mA; 1 mW

Constant Channel:

For the voltage output channel:

{V Name}: {Source} V; {I Name}: {Compliance} A

For the current output channel:

{I Name}: {Source} A; {V Name}: {Compliance} V

For the common channel:

{V Name}: COMMON

Example: VSUB: -1 V; ISUB: 1 mA

To Change List Display Properties

Edit > List Display Properties...

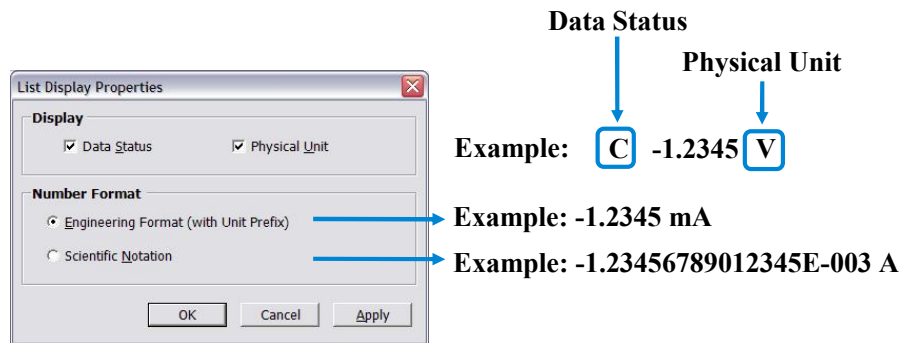

This dialog box is used to set the data display format in the List Display area. This dialog box is opened by clicking the Properties... button in the List Display area or by selecting Edit > List Display Properties... menu of the Data Display window.

Display:

Check the following check box to add the data status or the physical unit to data. Unchecking the box removes it.

- Data Status: Adds or removes the status code before data.
- Physical Unit: Adds or removes the physical unit after data.

Number Format:

Selects the data display format from the following formats.

- Engineering Format (with Unit Prefix):

Data display with arithmetic point, SI prefix, and unit.

Example: -1.2345 mA

- Scientific Notation:

Data display with arithmetic point, exponential part (E, +/- sign, and three-digit number), and unit.

Example: -1.23456789012345E-003 A

To Change Display Setup

View > Display Setup...

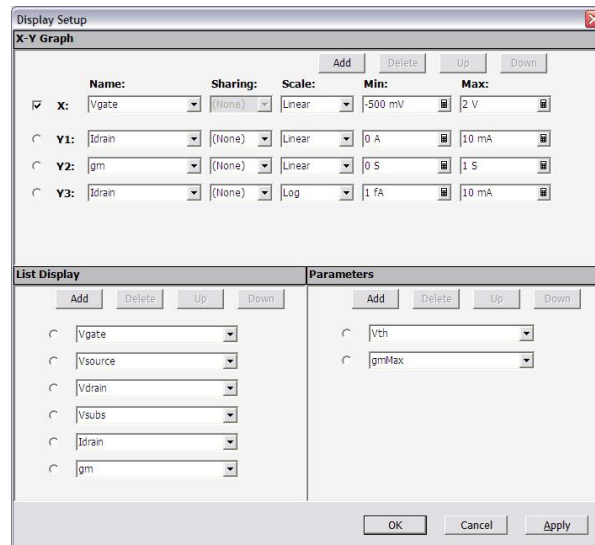

This dialog box is used to change the graph scale and data to be displayed in the Data Display window.

The X-Y Graph area sets the X and Y1 to Y8 axes of the X-Y Graph Plot area.

Name: Specifies the parameter for the axis

- Sharing: Specifies the group for sharing the Y axis scale. Select from Group 1, Group 2, Group 3, Group 4, or None (no grouping). The Scale, Min, and Max values are shared by the Y axes in the same group. The scale set by Run Time Auto Scale, Auto Scale, Zoom in, and/or Zoom out are also shared. If another layer on the Data Display window contains an X-Y trace which has the same name for both its grouped Y parameter and its X parameter, the scaling will also be shared by this X-Y trace.

- Scale: Scale of the axis, Linear or Log

- Min: Minimum value of the axis

- Max: Maximum value of the axis

The List Display area selects the variables to be listed in the List Display area. Up to 20 variables can be set.

The Parameters area selects the variables to be listed in the Parameters area. Up to 20 parameters can be set.

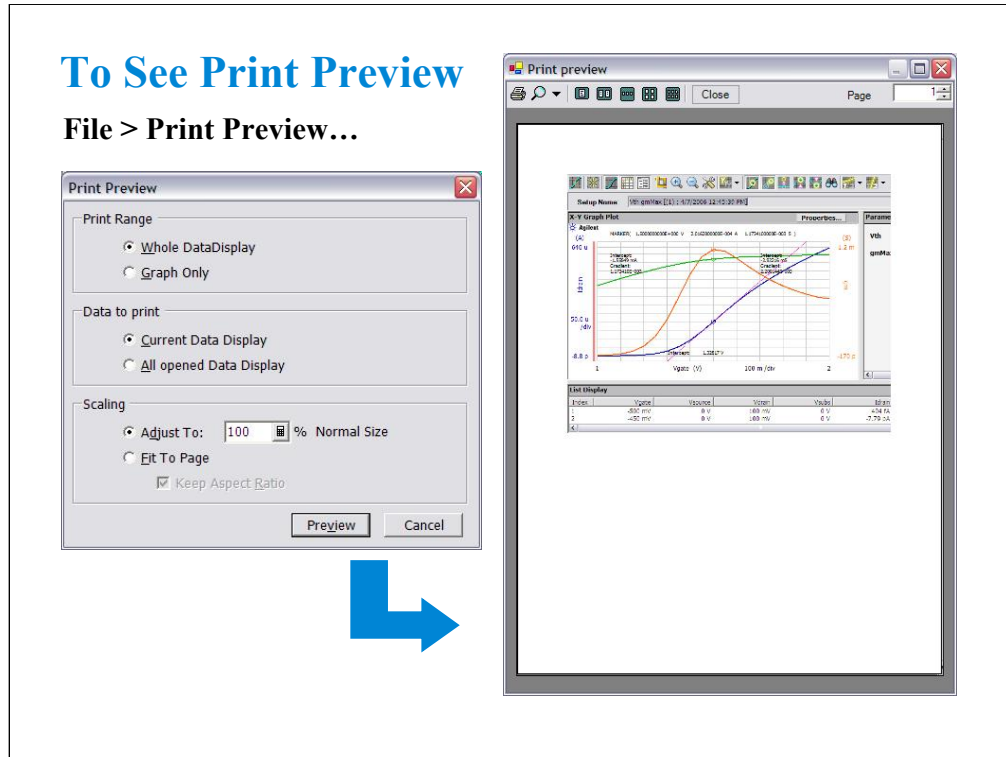

The Data Display window provides the File > Print Preview... function to show the print preview. This is an example of the print preview.

- Select the File > Print Preview menu to open the Print Preview dialog box.
- Set the Print Range, Data to print, and Scaling.
- Click Preview button. The Print preview window is displayed.

To Print Display Data

File > Print

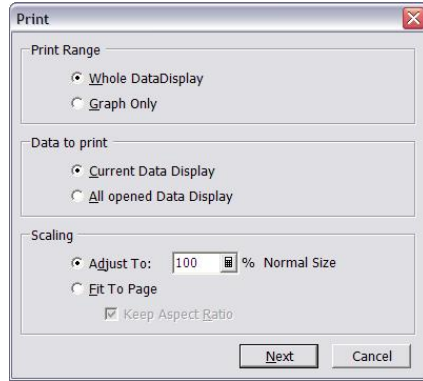

File > Save Image As...

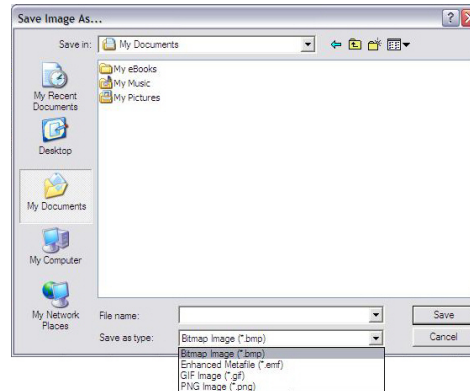

bmp, emf, gif, or png format

The Data Display window provides the display image output capability to a printer or a file.

Before printing, connect a printer to the B1500A/B1505A via the parallel interface or the LAN, and set up it by using the Add Printer Wizard of Windows. After that, do following.

- Select the File > Print menu to open the Print dialog box.
- Set the Print Range, Data to print, and Scaling.
- Click Next button.
- Select the printer, and set the Properties.
- Click OK button.

You can export the display image to a file as shown below.

- Select the File > Save Image As... menu to open the Save Image As... dialog box.
- Select the format (file type) from Save As Type menu.
- Enter the file name.
- Click Save button.

The file can be imported by the graphics software that supports the exported file type. The EasyEXPERT supports the following types.

- bmp: Bitmap image
- emf: Enhanced metafile
- gif: GIF image
- png: PNG image

To Copy Graph Plot

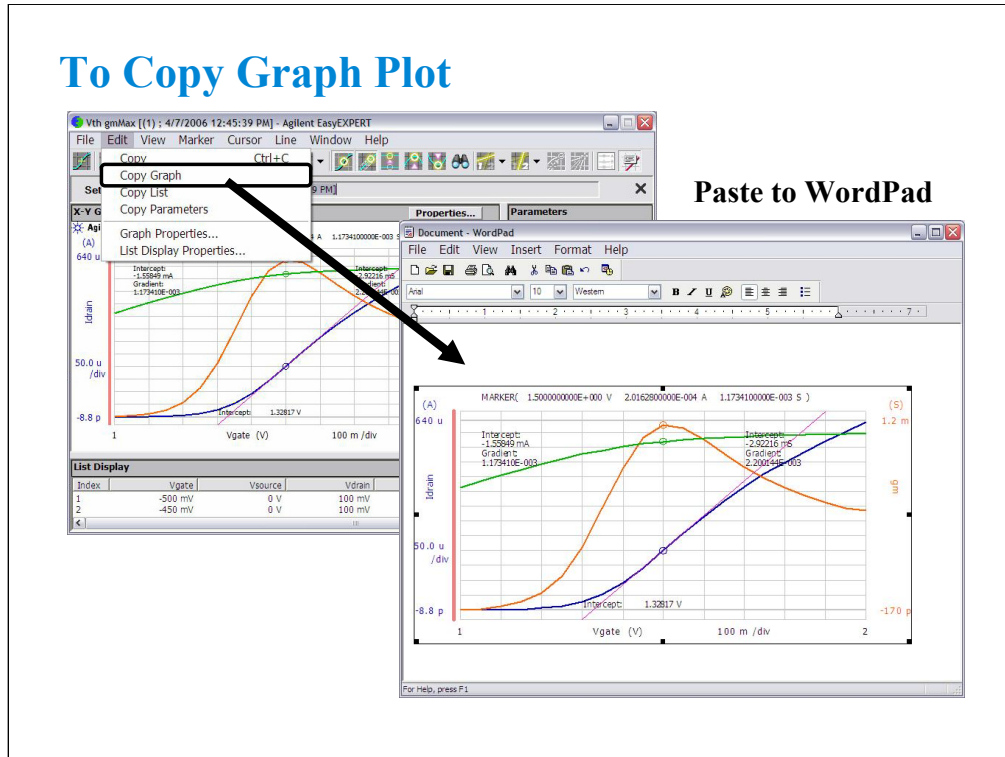

You can copy graph image to the clipboard, and paste it to a word processing software. In the above example, the graph image is pasted to the WordPad.

This is an example of the copy and paste operation.

- Select the Edit > Copy Graph menu on the Data Display window.
- Select the Edit > Paste menu on the WordPad.

To Copy List Data

The screenshot shows the Agilent EasyEXPERT interface. The main window displays a graph of Idrain (uA) versus Vgate (V). Below the graph is a 'List Display' window containing a table of data points. An arrow points from the 'Copy List' menu option in the 'Edit' menu to the data list. Another arrow points from the 'Copy List' menu option to a Notepad window titled 'Untitled - Notepad', which contains the copied data. A third arrow points from the data list to a spreadsheet application window titled 'test', indicating that the data can also be opened in spreadsheet software.

Index	Vgate	Vsource	Vdrain	Vsubs	Idrain	gm			
1	-500 mV	0 V	100 mV	0 V	404 fA	-163.88 pS			
2	-450 mV	0 V	100 mV	0 V	-7.79 pA	-81.58 pS			
3	-400 mV	0 V	100 mV	0 V	-7.754 pA	2.7299999999999999 pS			
4	-350 mV	0 V	100 mV	0 V	-7.517 pA	-660.00000000000007 fS			
5	-300 mV	0 V	100 mV	0 V	-7.82 pA	-3.0699999999999998 pS			
6	-250 mV	0 V	100 mV	0 V	-7.824 pA	-810.0000000000001 fS			
7	-200 mV	0 V	100 mV	0 V	-7.901 pA	-850.0000000000006 fS			
8	-150 mV	0 V	100 mV	0 V	-7.909 pA	-1.7999999999999998 pS			
9	-100 mV	0 V	100 mV	0 V	-8.075 pA	32.02 pS			
10	-50 mV	0 V	100 mV	0 V	-4.873 pA	-6.380000000000001 pS			
11	0 V	0 V	100 mV	0 V	-8.295 pA	-34.72 pS			
12	50 mV	0 V	100 mV	0 V	-8.345 pA	3.030000000000001 pS			
13	100 mV	0 V	100 mV	0 V	-7.995 pA	-2.4299999999999999 pS			
14	150 mV	0 V	100 mV	0 V	-8.588 pA	-6.180000000000001 pS			
15	200 mV	0 V	100 mV	0 V	-8.51 pA	-1.43 pS			
16	250 mV	0 V	100 mV	0 V	-8.731 pA	-1.31 pS			
17	300 mV	0 V	100 mV	0 V	-8.761 pA	-560.0000000000022 fS			
18	350 mV	0 V	100 mV	0 V	-8.785 pA	2.09 pS			
19	400 mV	0 V	100 mV	0 V	-8.552 pA	16.9 pS			
20	450 mV	0 V	100 mV	0 V	-7.097 pA	65.27 pS			
21	500 mV	0 V	100 mV	0 V	-2.025 pA	202.85 pS			
22	550 mV	0 V	100 mV	0 V	13.188 pA	613.21 pS			
23	600 mV	0 V	100 mV	0 V	59.496 pA	1.8873 nS			
24	650 mV	0 V	100 mV	0 V	201.913 pA	5.78764 nS			
25	700 mV	0 V	100 mV	0 V	638.76 pA	18.64017 nS			
26	750 mV	0 V	100 mV	0 V	2.06593 nA	54.2379 nS			
27	800 mV	0 V	100 mV	0 V	6.06405 nA	167.8077 nS			
28	850 mV	0 V	100 mV	0 V	18.8467 nA	493.4585 nS			
29	900 mV	0 V	100 mV	0 V	55.4099 nA	1.386893 uS			
30	950 mV	0 V	100 mV	0 V	157.536 nA	3.714431 uS			
31	1000 mV	0 V	100 mV	0 V	426.853 nA	9.312229999999999 uS			
32	1050 mV	0 V	100 mV	0 V	1.088759 uA	21.97377 uS			

You can copy the data list to the clipboard, and paste it to a word processing software. In the above example, the data list is pasted to the Notepad.

This is an example of the copy and paste operation.

- Select the Edit > Copy List menu on the Data Display window.
- Select the Edit > Paste menu on the Notepad.

You can save the data as a text file, and read it by using a spreadsheet software. Data elements are separated by a tab.

Note:

As same as the Copy List function, the Copy Parameter function is used to copy the data in the Parameter area.

To Save Analysis Result

- Select File > Update Test Result → Saves graph information to data record.
- Select File > Save Image As... → Saves graph image as a file.

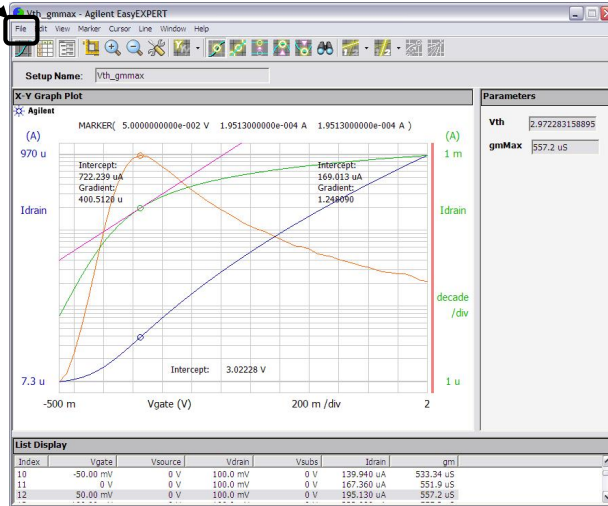

To leave the graph modification information such as scaling, marker, cursor, and line on the graph, select the File > Update Test Result menu.

You can see the all information when you open the graph again. Note that the modification information will be destroyed if you did not do it.

To save the graph image as a file, select the File > Save Image As... menu.

You can save the image as a bmp, emf, gif, or png file.

Class Exercise

Use the analysis tools.

- 1. Use your test setup (for example, GMMAX in the Demo preset group) and perform measurement .**
- 2. Enable marker and draw line. Try it for all line types.**
- 3. Copy/paste/save data list, and open it by using a spreadsheet software (optional, if you can).**
- 4. Save analysis condition. Re-open the test record.**
- 5. Export your test record. And import it.**

Note:

To Use Preview Window

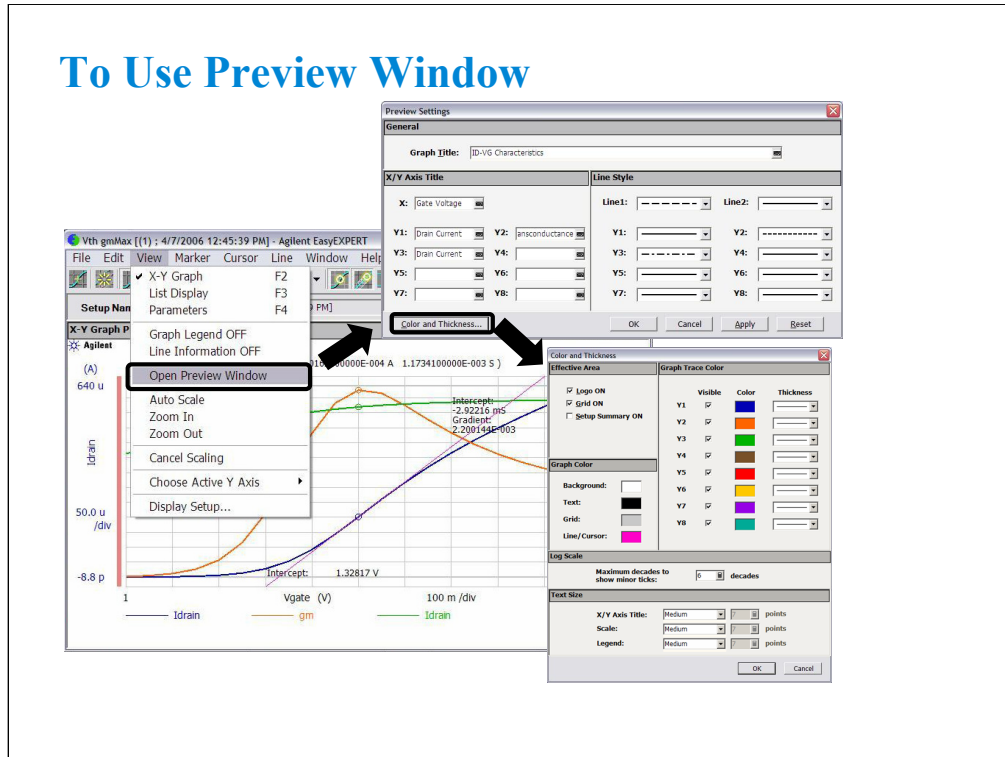

The Data Display window provides the File > Print... function to print the graph image. However, you may want to set the graph title and change the line style. Then use the Preview window. The Preview window is used to see and print the graph image you modified.

Select the View > Open Preview Window to open the Preview window and the Preview Settings dialog box. And use the Preview Settings dialog box to set the title of graph, X axis, and Y axis, and change the line style. To change the color and thickness, use the Color and Thickness dialog box opened by clicking the Color and Thickness... button.

Clicking OK button in the Preview Settings dialog box applies the modification to the Preview window and closes the dialog box.

Note:

The graph image in the Preview window cannot be saved.

To Use Preview Window

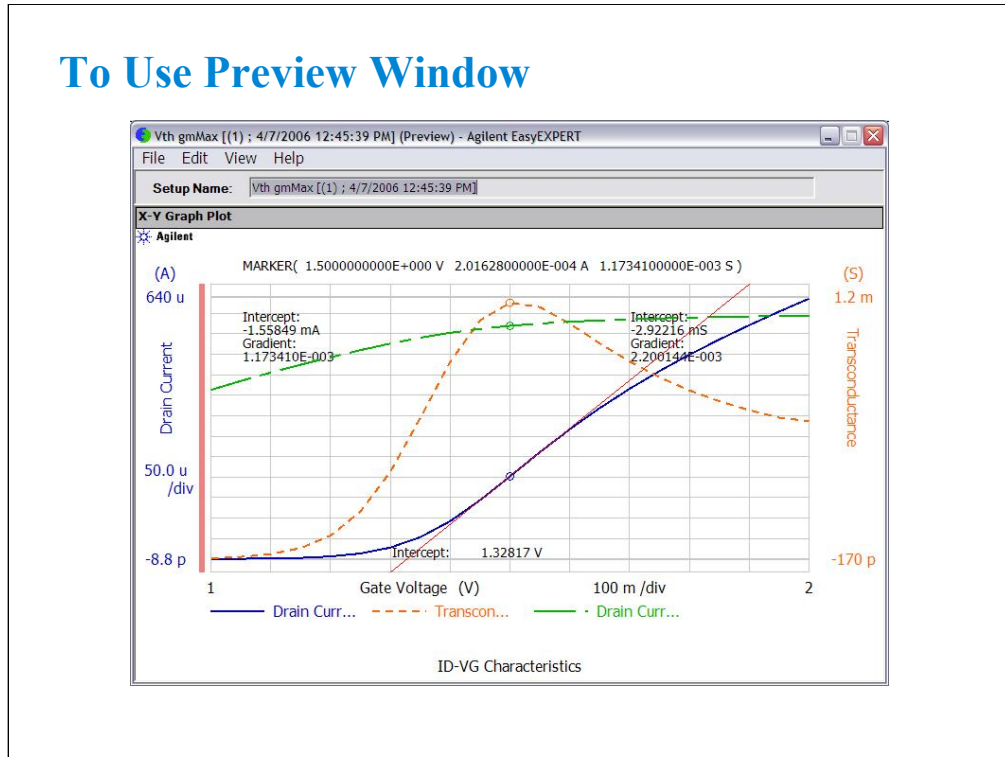

This example is result of the changes shown in the previous page.
Line style was changed as shown above. The titles are set as follows.
Graph title: ID-VG Characteristics
X axis title: Gate Voltage
Y1 axis title: Drain Current
Y2 axis title: Transconductance
Y3 axis title: Drain Current
Also color of line1 was changed to red, and thickness of trace was changed.

To change the setup again, open the Preview Settings dialog box by selecting the View > Preview Settings... menu.

Class Exercise

Use the Preview window.

- 1. Use your test record used in the previous exercise.**
- 2. Change the graph image as you want.**
 - Add graph title and change axis title.**
 - Change line style**
 - Change color and thickness**
- 3. Print the graph image if a printer is available.**

Note:



Note:



3

Classic Test Environment



In This Module

- **Classic Test Execution Mode**
- **I/V Sweep Measurement**
- **Multi Channel I/V Sweep Measurement**
- **I/V List Sweep Measurement**
- **I/V-t Sampling Measurement**
- **C-V Sweep Measurement**
- **Switching Matrix Control**
- **Direct Control**

Note:

Classic Test Execution Mode

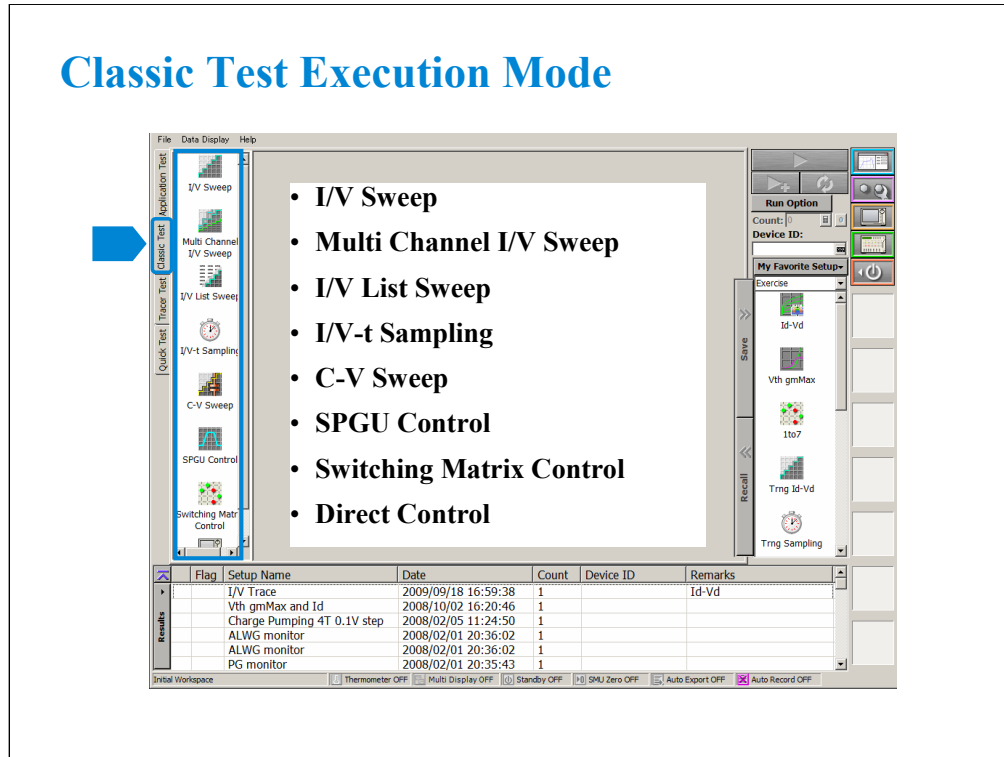

To use the classic test mode, click the Classic Test tab. And select the execution mode. The following modes are available.

- I/V Sweep: For X-Y characteristics measurement of I or V.
- Multi Channel I/V Sweep: For simultaneous multi channel (up to 10) sweep measurement of I or V.
- I/V List Sweep: For multi channel (up to 10) I/V sweep measurement using list data.
- I/V-t Sampling: For time-Y characteristics measurement of I or V.
- C-V Sweep: For DC bias-impedance characteristics measurement.
- SPGU Control: For voltage pulse output. Not available for B1505A.
- Switching Matrix Control: For B2200/E5250 switching matrix control. Not available for B1505A.
- Direct Control: For various measurements (e.g. C-f measurement, Quasi-Static C-V measurement) using Agilent FLEX commands.

I/V Sweep Measurement

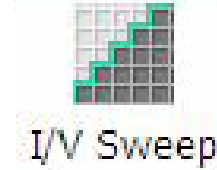

- To Define Source/Masurement Channels
- To Read Time Stamp Data and Data Index
- To Set Source Outputs (VAR1, VAR2, VAR1', Pulse, CONST)
- To Set Timing Parameters
- To Set Sweep Abort Function
- Range, ADC, Advanced, SPGU
- To Set User Functions
- To Set Analysis Functions
- To Set Auto Analysis Function
- To Set Display Parameters (X-Y Graph, Data List, Parameter)

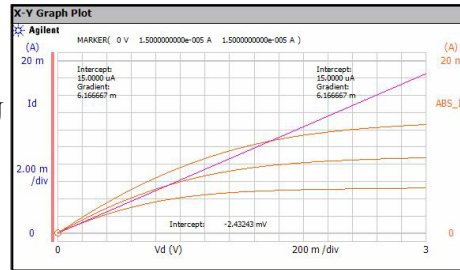

This section explains how to perform I/V sweep measurement. You will perform the above tasks to execute the I/V sweep measurement.

To Define Source/Measurement Channels



I/V Sweep

Channel Setup

I/V Sweep

Setup Name:

Channel Setup | Measurement Setup | Function Setup | Auto Analysis Setup | Display Setup

Channel Definition

Add SMU
Add SPGU
Delete
Up
Down

Unit:	V Name:	I Name:	Mode:	Function:
SMU4:HR	Vd	Id	VPULSE	VAR1
SMU3:HR	Vg	Ig	V	VAR2
SMU2:HP	Vs	Is	V	CONST
SMU1:HP	Vsub	Isub	V	VAR1'

SMU Channel Definition

- V name/I name
- I/V/IPULSE/VPULSE/Common
- VAR1/VAR2/VAR1'/CONST

SPGU Channel Definition

- V name
- VPULSE/ALWG

Miscellaneous Variables

Time Stamp Name:
Index Name:

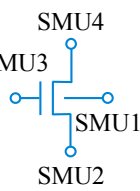

SMU4
SMU3
SMU2
SMU1

Click the I/V Sweep icon and open the setup editor. Then click the Channel Setup tab to display the channel definition screen.

1. Enter the Setup Name for the test setup to be defined on the setup editor.
2. List SMUs used for source output or measurement, and set the following parameters.
 - Unit: SMU name or number. The GNDU (ground unit) can be set instead of a SMU.
 - V Name: Variable name for the voltage measurement or source data
 - I Name: Variable name for the current measurement or source data
 - Mode: Source output mode, V (voltage), I (current), VPULSE (voltage pulse), IPULSE (current pulse), or COMMON (ground)
 - Function: Source output function, VAR1 (primary sweep), VAR2 (secondary sweep), VAR1' (synchronous sweep), CONST (constant)

V Name and I Name are used to specify the parameters displayed on the Data Display window. The display parameters are selected on the Display Setup tab screen. For the GNDU, 0 V is returned to the V variable and no data is returned to the I variable.

To use the SPGU channels, click the Add SPGU button. The SPGU channel setup row will appear. Then set the following parameters.

 - Unit: SPGU name or number
 - V Name: Variable name for the voltage data. No data is returned to the variable.
 - Mode: SPGU output mode. VPULSE (voltage pulse) or ALWG (arbitrary linear waveform voltage) for all SPGU.

To Read Time Stamp Data and Index



Channel Setup

Channel Definition

Unit:	V Name:	I Name:	Mode:	Function:
SMU4:HR	Vd	Iid	V PULSE	VAR1
SMU3:HR	Vg	Ig	V	VAR2
SMU2:HP	Vs	Is	V	CONST
SMU1:HP	Vsub	Isub	V	VAR1'

Miscellaneous Variables

Time Stamp Name: Index Name:

You can read measurement data by using the Data Display window. Parameters displayed on the window are selected on the Display Setup tab screen. If you enter the variable name in the V Name, I Name, Time Stamp Name, and/or Index Name entry fields, you can choose the variables as the display parameters.

Note:

The time stamp is the time the measurement is started for each measurement point.

The index is the index number for each measurement data.

To Set Primary Sweep Source



Measurement Setup

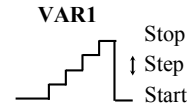

The Measurement Setup tab screen is used to set the source output value and timing parameters.

At the VAR1 area, you set the primary sweep source output.

- Unit: SMU name or number
- Name: Variable name of source output
- Direction: Single (start to stop) or Double (start to stop to start)
- Linear/Log: Linear sweep or Log sweep
- Start: Source output start value
- Stop: Source output stop value
- Step: Source output incremental step value
- No of Step: Number of sweep steps
- Compliance: SMU compliance value
- Pwr Comp: SMU power compliance value

To Set Secondary Sweep Source



Measurement Setup

I/V Sweep Setup Name: Trng Id-Vd

Measurement Setup | Function Setup | Auto Analysis Setup | Display Setup

VAR1	VAR2	VAR1'
Unit: SMU4:HR	SMU3:HR	Unit: SMU1:HP
Name: Vd	Vg	Name: Vsub
Direction: Single		Offset: 0 V
Linear/Log: LINEAR		Ratio: 0
Start: 0 V	1 V	Compliance: 100 mA
Stop: 3 V	2 V	Pwr Comp: OFF
Step: 60 mV	500 mV	SMU Pulse
No of Step: 51	3	Unit: SMU4:HR
Compliance: 10 mA	1 mA	Period: 10 ms
Pwr Comp: OFF	OFF	Width: 1 ms
		Base: 0 V

Timing: Hold: 0 s Delay: 0 s * Sweep CONTINUE AT ANY status

Unit:	V Name:	I Name:	Mode:	Source:	Compliance:
SMU2:HP	Vs	Is	V	0 V	50 mA

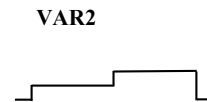
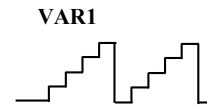

At the VAR2 area, you set the secondary sweep source output.

- Unit: SMU name or number
- Name: Variable name of source output
- Start: Source output start value
- Stop: Source output stop value
- Step: Source output incremental step value
- No of Step: Number of sweep steps
- Compliance: SMU compliance value
- Pwr Comp: SMU power compliance value

To Set Synchronous Sweep Source



Measurement Setup

Unit:	V Name:	I Name:	Mode:	Source:	Compliance:
SMU2:HP	Vs	Is	V	0 V	50 mA



At the VAR1' area, you set the synchronous sweep source output.

- Unit: SMU name or number
- Name: Variable name of source output
- Offset: B value of the above formula.
- Ratio: A value of the above formula.
- Compliance: SMU compliance value
- Pwr Comp: SMU power compliance value

The VAR1' output is expressed by the following formula.

$$\text{VAR1' output} = A \times (\text{VAR1 output}) + B$$

To Set Pulse Output



Measurement Setup

I/V Sweep Setup Name: Trng Id-Vd

Measurement Setup | Function Setup | Auto Analysis Setup | Display Setup

VAR1	VAR2	VAR1'
Unit: SMU4:HR	SMU3:HR	Unit: SMU1:HP
Name: Vd	Vg	Name: Vsub
Direction: Single		Offset: 0 V
Linear/Log: LINEAR		Ratio: 0
Start: 0 V	1 V	Compliance: 100 mA
Stop: 3 V	2 V	Pwr Comp: OFF
Step: 60 mV	500 mV	SMU Pulse
No of Step: 51	3	Unit: SMU4:HR
Compliance: 10 mA	1 mA	Period: 10 ms
Pwr Comp: OFF	OFF	Width: 1 ms
		Base: 0 V

Timing
Hold: 0 s Delay: 0 s * Sweep CONTINUE AT ANY status

Unit:	V Name:	I Name:	Mode:	Source:	Compliance:
SMU2:HP	Vs	Is	V	0 V	50 mA

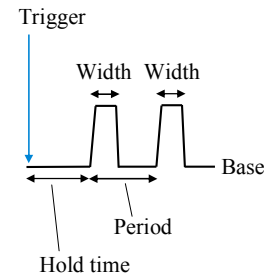

Delay time cannot be set.

At the SMU Pulse area, you set the SMU pulse timing parameter and the pulse base value.

- Unit: SMU name or number
- Period: Pulse period
- Width: Pulse width
- Base: Pulse base value

Only a SMU can be set to the pulse source.

To Set Constant Output



Measurement Setup

The screenshot shows the 'I/V Sweep' Measurement Setup window. The 'Constants' section at the bottom is highlighted with a blue box. It contains the following settings:

Unit:	V Name:	I Name:	Mode:	Source:	Compliance:
SMU2:HP	Vs	Is	V	0 V	50 mA

At the Constants area, you set the SMU constant output.

- Unit: SMU name or number
- V Name: Variable name for the voltage measurement or source data
- I Name: Variable name for the current measurement or source data
- Mode: Source output mode, V (voltage), I (current), VPULSE (voltage pulse), IPULSE (current pulse), or COMMON (ground)
- Source: SMU output value
- Compliance: SMU compliance value

To Set Timing Parameters

Measurement Setup

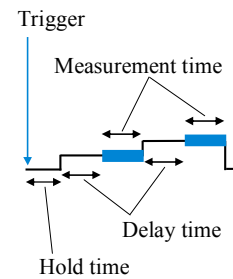
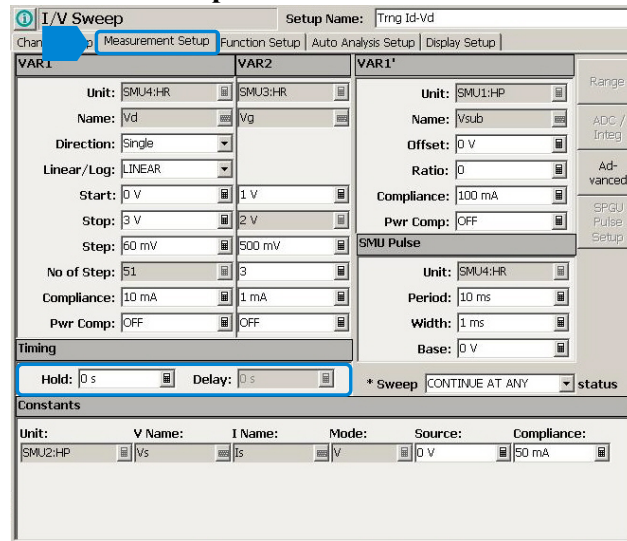

At the Timing area, you set the source output and measurement timing.

- Hold: Source output hold time. Time after the measurement trigger until starting delay time.
- Delay: Measurement start delay time. Time after the hold time until starting measurement.

When a SMU forces pulse, the delay time is ignored. Source output and measurement timing will be controlled by the pulse width and pulse period.

To Set Sweep Abort Function

Measurement Setup

The screenshot shows the 'I/V Sweep' measurement setup window. The 'Sweep' dropdown menu is highlighted in blue and set to 'CONTINUE AT ANY'. The interface is divided into sections for VAR1, VAR2, and VAR1' parameters, including units, names, directions, and compliance settings. A 'Timing' section at the bottom includes 'Hold' and 'Delay' fields. A 'Constants' table is also visible at the bottom.

Unit:	V Name:	I Name:	Mode:	Source:	Compliance:
SMU2:HP	Vs	Is	V	0 V	50 mA

**CONTINUE AT ANY
STOP AT ANY
ABNORMAL**
-Range overflow
-SMU compliance
-SMU oscillation

This field sets the sweep abort function.

When this field is CONTINUE AT ANY, the sweep measurement is not aborted.

When this field is STOP AT ANY ABNORMAL, the sweep measurement will be aborted when one of the following conditions is detected.

- Measurement range overflow
- SMU compliance
- SMU oscillation

To Set Ranging Mode

Measurement Setup

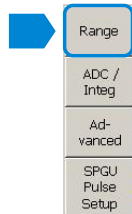

Not available when a SMU pulse is used.

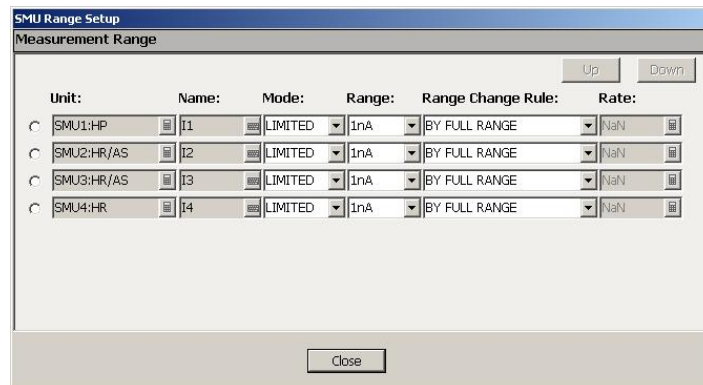

The Range button opens the SMU Range Setup dialog box. The dialog box is used to set the measurement ranging mode. This button is not available when a pulse source is used.

- Unit: SMU name or number
- Name: Variable name for the measurement data
- Mode: Ranging mode, AUTO, LIMITED, or FIXED
- Range: Range value
- Range Change Rule: BY FULL RANGE, GO UP AHEAD, or UP AND DOWN AHEAD
- Rate: Value used for range changing. See the following formula.

For the AUTO or LIMITED, SMU automatically selects the minimum range that covers the measurement value, and performs the measurement by using the range. For the limited auto ranging, the instrument does not use the range lower than the specified range value. For example, if you select the 100 nA limited auto ranging, the instrument never uses the 10 nA range and below.

BY FULL RANGE performs normal auto ranging operation.

For the GO UP AHEAD and UP AND DOWN AHEAD rules, specify the *Rate* value, 11 to 100, which fixes the boundary of the ranging. The ranging occurs when the measurement data goes across the *boundary* values shown below.

$$\text{go up boundary} = \text{present measurement range} \times \text{Rate} / 100$$

$$\text{go down boundary} = \text{present measurement range} \times \text{Rate} / 1000$$

The *go down boundary* is available only for the UP AND DOWN AHEAD rule.

To Set ADC/Integration Time

Measurement Setup

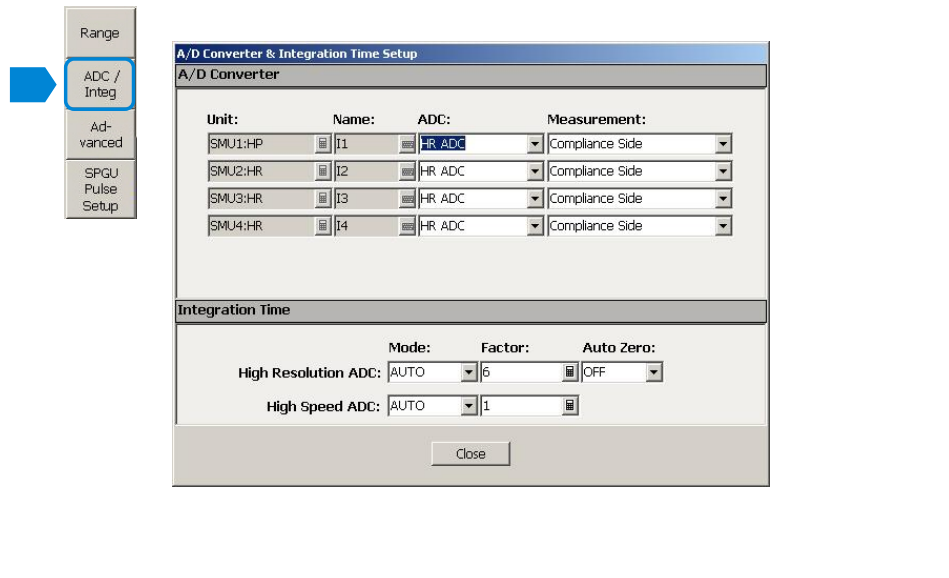

The ADC/Integ button opens the A/D Converter & Integration Time Setup dialog box. The dialog box is used to select the ADC for each SMU and set the integration time for each ADC (high resolution or high speed).

A/D Converter:

- Unit: SMU name or number
 - Name: Variable name of the measurement data
 - ADC: ADC type, HR ADC (high resolution) or HS ADC (high speed)
 - Measurement: Compliance side measurement or Force and Compliance sides measurement.
- HR ADC is not available for HCSPMU, HVSPMU, and the measurement which uses SMU pulse.
Force and Compliance sides measurement is not available for HRSPMU, MPSPMU, and HPSMU.

Integration Time:

- Mode: ADC operation mode
AUTO, MANUAL, or PLC for HR ADC
AUTO, MANUAL, PLC, or TIME for HS ADC
TIME or PLC for the measurements using SMU pulse.
- Factor: Coefficient for the reference value of the integration time.
- Auto Zero: Auto Zero function ON or OFF. For HR ADC.

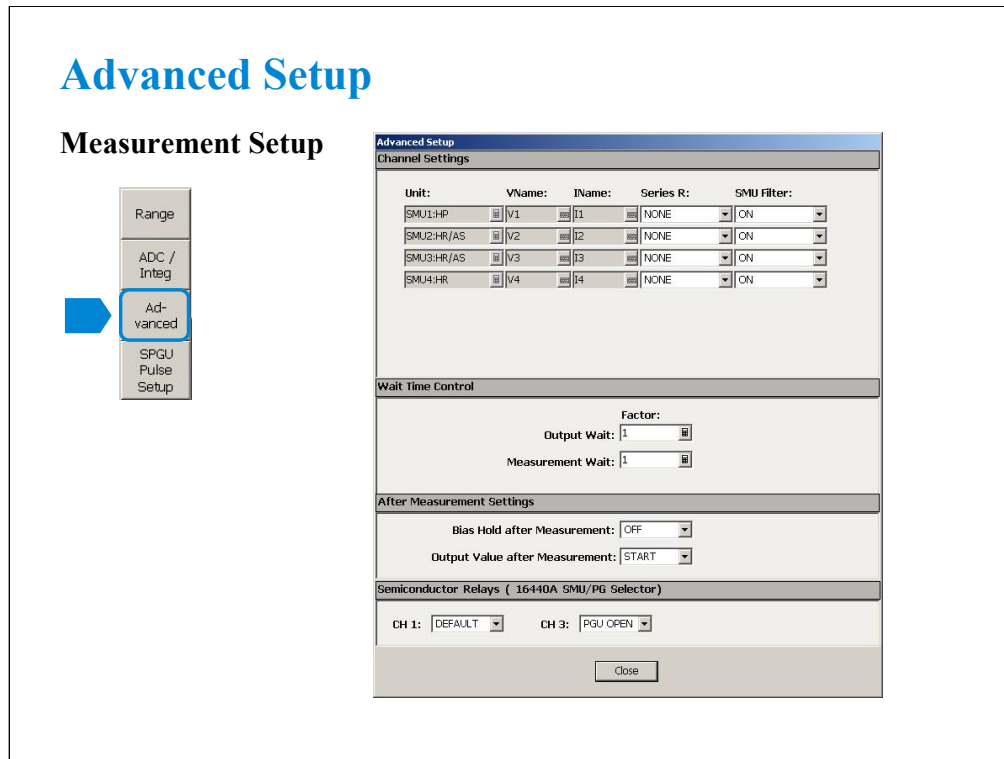

The Advanced button opens the Advanced Setup dialog box. The dialog box is used to set the SMU filter and SMU series resistor settings, the wait time, the after measurement settings, and the 16440A selector semiconductor relay setting.

Channel Settings:

- Unit: SMU name or number
- V Name: Variable name for the voltage measurement or source data
- I Name: Variable name for the current measurement or source data
- Series R: SMU series resistor NONE or 1MOHM (1000000 ohm)
- SMU Filter: SMU filter ON or OFF

Wait Time Control:

- Factor: Coefficient for the reference value of the wait time. For details, see online help or User's Guide.

After Measurement Settings:

- Bias Hold after Measurement: Bias hold function ON or OFF.
- Output Value after Measurement: Source output value after measurement. START (sweep start value), STOP (sweep stop value), SOURCE (sampling output source value), or BASE (sampling output base value)

Note: Pulse channel output after measurement is always Base value.

Semiconductor Relays (16440A SMU/PG Selector):

- CH1: Default or PGU OPEN
- CH3: Default or PGU OPEN

The fields define the selector channel's switch condition during the measurement. Default is the setting defined on the SMU/PG Selector screen of the Configuration window.

SPGU Pulse Setup

Measurement Setup

The screenshot shows the 'SPGU Pulse Setup' window. On the left, a vertical menu contains 'Range', 'ADC / Integ', 'Ad- vanced', and 'SPGU Pulse Setup' (highlighted with a blue arrow). The main window is divided into 'Global Settings' and 'Pulse Settings'. 'Global Settings' includes 'Period: 1 us', 'FREE RUN' (selected), 'PULSE COUNT: 1', 'Load Z', and 'Pulse Switch'. 'Pulse Settings' includes 'SPGU setup view order: Up Down' and two channel configuration sections. Each section has 'Unit:' (SPGU1HV, SPGU2HV), 'VName:' (SPGU/V1, SPGU/V2), and 'Type:' (2-Level Pulse). Parameters for each channel include Base (0 V), Peak (500 mV), Delay (0 s), Width (100 ns), Leading (20 ns), and Trailing (20 ns). Two oscilloscope-like waveforms show the pulse shapes for each channel.

This button is available when a SPGU channel is defined in Channel Setup.

If a SPGU channel is defined and set to the VPULSE mode on the Channel Setup screen, the SPGU Pulse Setup button is effective. This button opens the SPGU Pulse Setup window which is used to define the voltage pulse output by the specified SPGU channels. Maximum 10 SPGU channels can be used. Not available for B1505A.

SPGU ALWG Setup

Measurement Setup

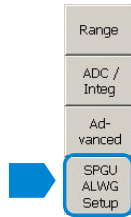

This button is available when a SPGU channel is defined in Channel Setup.

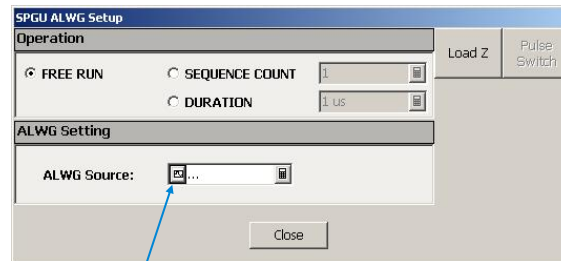

This button opens the Define ALWG Waveform window used to define the arbitrary linear waveform.

If a SPGU channel is defined and set to the ALWG mode on the Channel Setup screen, the SPGU ALWG Setup button is effective. This button opens the SPGU ALWG Setup window which is used to define the arbitrary linear waveform voltage output by the specified SPGU channels. Maximum 10 SPGU channels can be used. Not available for B1505A.

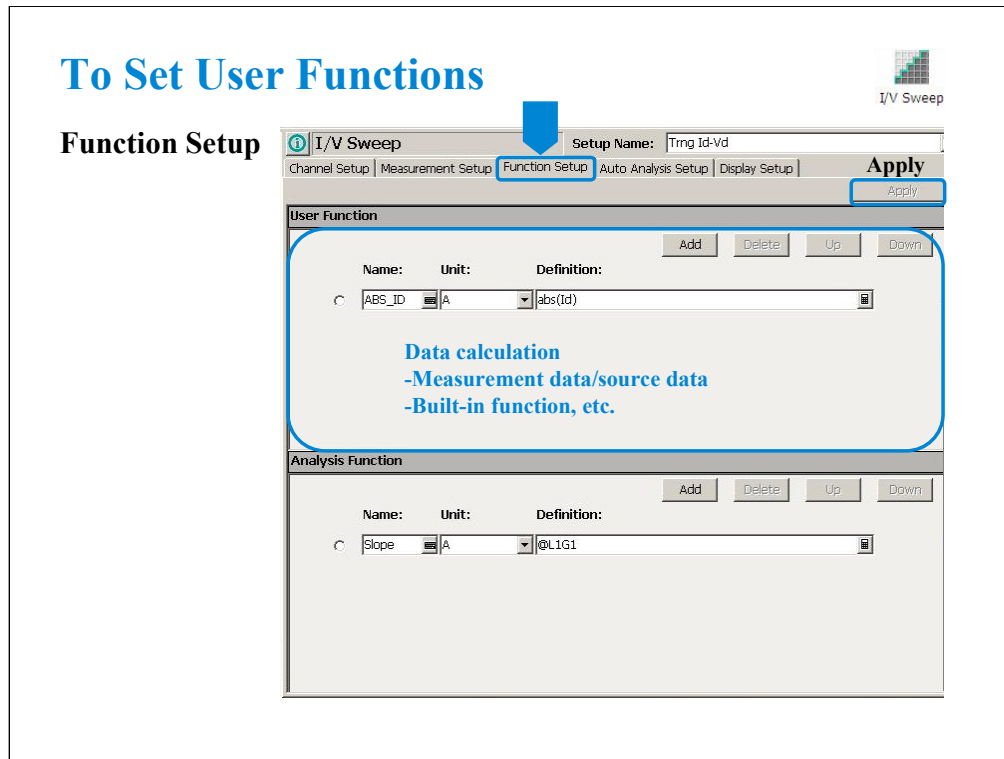

Click the Function Setup tab to display the User Function/Analysis Function setup screen. The user functions can be displayed on the X-Y Graph Plot, List Display, and Parameters area of the Data Display window. Up to 20 functions can be set.

Name: Function name

Unit: Unit of the function

Definition: Definition of the function. The following identifiers can be used.

- Variables for the measurement/output data used in this test
- Functions defined in the above lines
- Local variables passed from the application test that calls this test as a component
- Built-in functions and global variables

For details, see online help or User's Guide.

Note:

The Apply button performs calculation of the definition in this screen. If this button is clicked when the Data Display window associated with this test has been opened, the display is also updated. The associated Data Display window will be the Data Display window that displays the last measurement data or that is recalled at last.

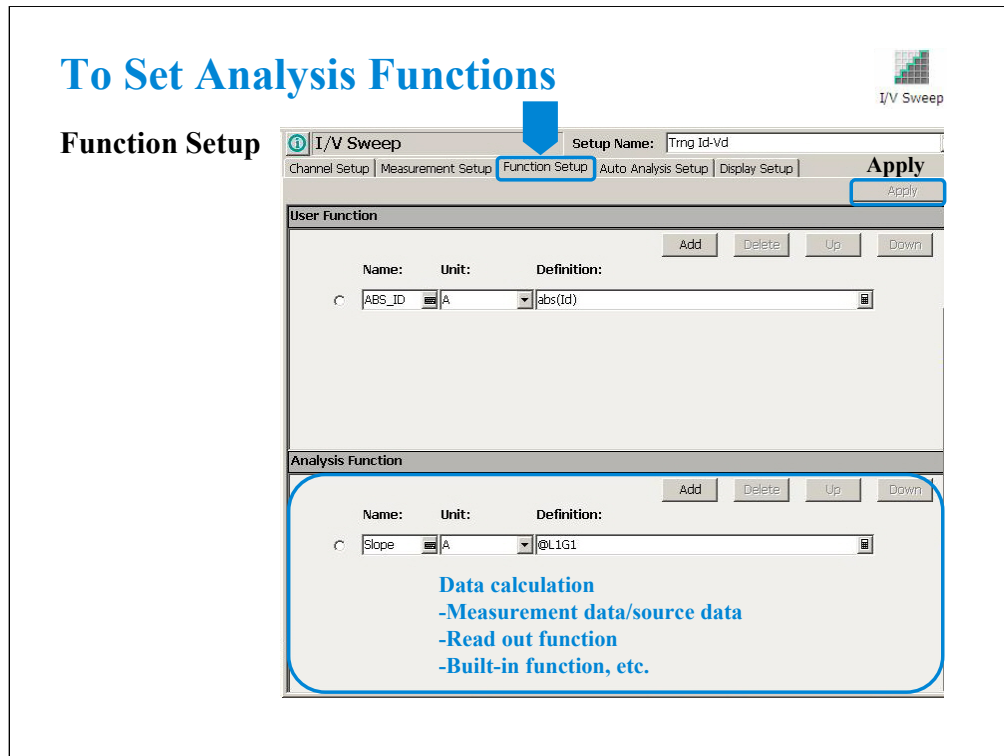

The analysis functions can be displayed on the Parameters area of the Data Display window. Up to 20 functions can be set.

Name: Function name

Unit: Unit of the function

Definition: Definition of the function. The following identifiers can be used.

- Variables for the measurement/output data used in this test
- Functions defined in the above lines
- Local variables passed from the application test that calls this test as a component
- Built-in functions and global variables
- Read out functions

For details, see online help or User's Guide.

Note:

The Apply button performs calculation of the definition in this screen. If this button is clicked when the Data Display window associated with this test has been opened, the display is also updated. The associated Data Display window will be the Data Display window that displays the last measurement data or that is recalled at last.

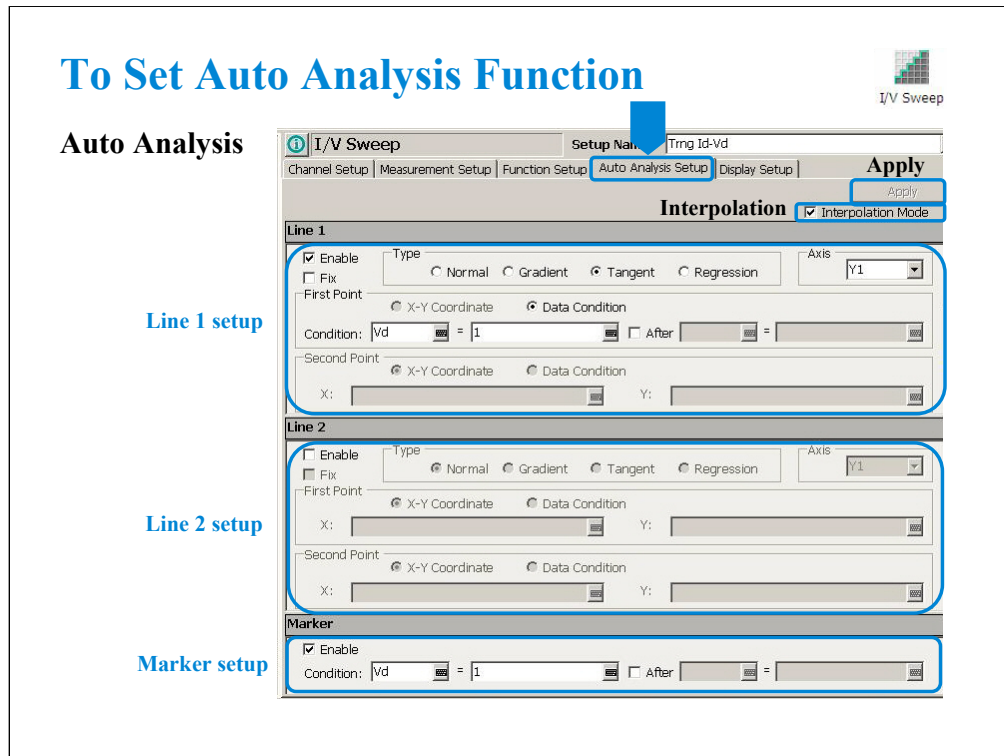

Click the Auto Analysis Setup tab to display the auto analysis setup screen. The auto analysis capability allows you to display/move the marker/line on the data graph automatically after measurement. The above example displays marker at $V_d=1$ V point and draw a tangent line for this point.

Interpolation Mode: Check this box to enable the interpolation mode. You can position marker between measurement points.

Line 1, Line 2: This area sets the line 1 or line 2 automatically displayed and moved to the specified position after the measurement. Check Enable box to enable the line.

For Type, select a line type, Normal, Gradient, Tangent, or Regression.

For Axis, select the axis effective for the line.

In First Point and Second Point, specify the cursor points used to draw line.

In Gradient, specify the slope of the Gradient line.

Marker: This area sets the marker automatically displayed and moved to the specified position after the measurement. Check Enable box to enable the marker.

For Condition, enter a variable name and a condition expression to specify where you want the marker to display.

For After, check this box to enable the additional condition. And enter a second variable and condition expression. This sets up a search start condition for finding specified point.

For example, you can specify the following expressions to search for a measurement point that satisfies the first condition after the second condition is satisfied.

Condition: $[DGM] = [MAX(DGM)*0.01]$ [x] After $[DGM] = [MAX(DGM)]$

Note:

The Apply button performs calculation of the definition in this screen. If this button is clicked when the Data Display window associated with this test has been opened, the display is also updated. The associated Data Display window will be the Data Display window that displays the last measurement data or that is recalled at last.

To Set X-Y Graph Display

Display Setup



I/V Sweep
Setup Name: Trng Id-Vd

Channel Setup
Measurement Setup
Function Setup
Auto Analysis Setup
Display Setup

X-Y Graph
Add Delete Up Down

	Name:	Sharing:	Scale:	Min:	Max:
<input checked="" type="checkbox"/>	X: vd	(None)	Linear	0 V	3 V
<input type="checkbox"/>	Y1: Id	(None)	Linear	0 A	10 mA
<input type="checkbox"/>	Y2: ABS_ID	(None)	Linear	0 A	10 mA

Specify X axis and Y axis

List Display
Add Delete Up Down

- Index
- Vg
- Vd
- Id

Parameters
Add Delete Up Down

- Slope

Click the Display Setup tab to display the display setup screen. The X-Y Graph area is used to set the X axis and Y axis of the X-Y Graph Plot area in the Data Display window.

- Name: Name of variable to plot on the X axis
- Scale: Linear or Log
- Min: Minimum value of the specified axis
- Max: Maximum value of the specified axis

To Set Data List Display

Display Setup

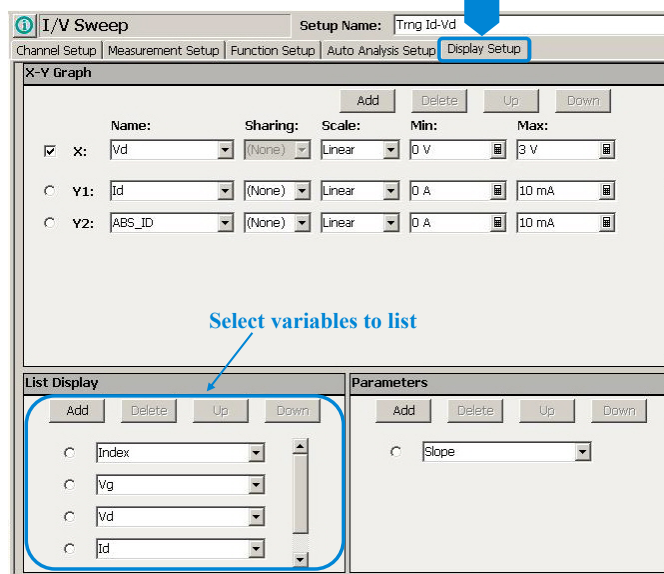

The List Display area selects the variables to be listed in the List Display area of the Data Display window. Up to 20 variables can be set.

To Set Parameters Display

Display Setup

I/V Sweep

Setup Name: Trng Id-Vd

Channel Setup | Measurement Setup | Function Setup | Auto Analysis Setup | **Display Setup**

X-Y Graph

	Name:	Sharing:	Scale:	Min:	Max:
<input checked="" type="checkbox"/>	X: vd	(None)	Linear	0 V	3 V
<input type="checkbox"/>	Y1: Id	(None)	Linear	0 A	10 mA
<input type="checkbox"/>	Y2: ABS_ID	(None)	Linear	0 A	10 mA

Select parameters to display

List Display

- Index
- Vg
- vd
- Id

Parameters

- Slope

The Parameters area selects the variables to be listed in the Parameters area of the Data Display window. Up to 20 parameters can be set.

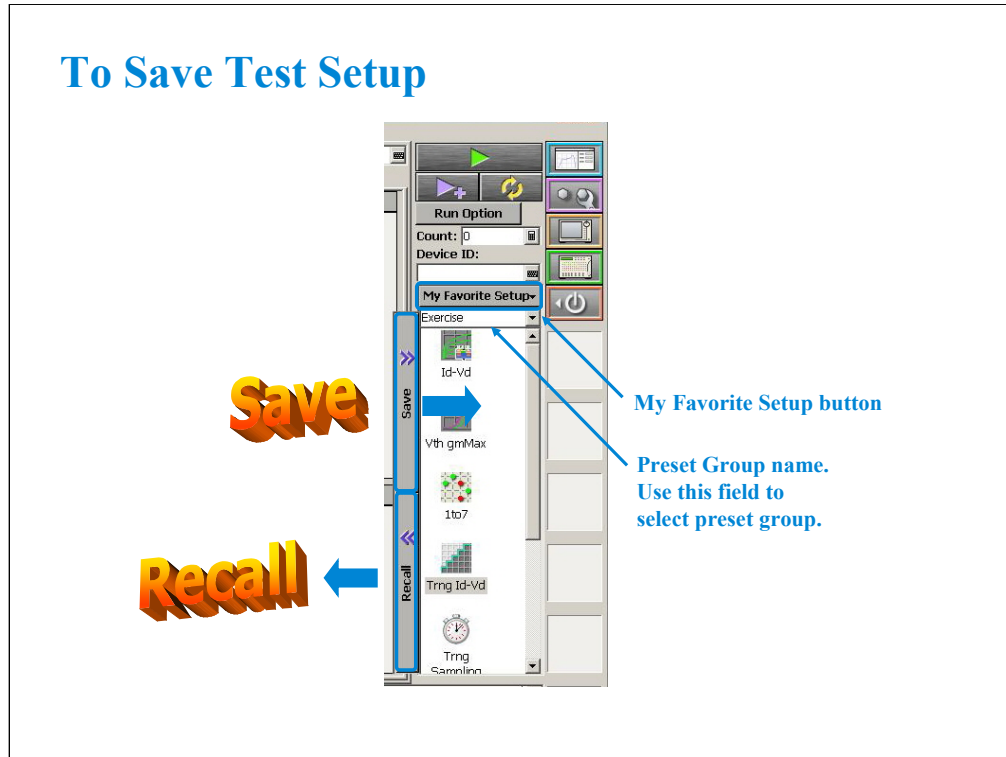

The test setups you create MUST be saved to the internal hard disk drive as “My Favorite Setup”.
To save the setup, click the Save button.
To recall the setup, click the Recall button.

You can organize the setups by using Preset Group. In the above example, the Demo group is selected and listed in the “My Favorite Setup”.

To create a new preset group, click the My Favorite Setup button to display the function menu, and select Add New Preset Group.
To select the available preset group, use the field below the My Favorite Setup button.

To Export/Import Your Preset Group



You can export/import your preset group.

To export the present preset group, click the My Favorite Setup button, select Export, and specify the folder and the name of the preset group to export.

To import the preset group, click the My Favorite Setup button, select Import, and specify the preset group to import.

Class Exercise



Define test setup and perform test.

1. Click I/V Sweep icon and open setup editor.
2. Define test setup as shown in the previous pages.
3. Save it as Trng Id-Vd.
4. Connect device, and perform test.
5. Export preset group, and import it.

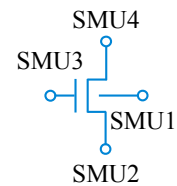

Note:

Measurement Result Example

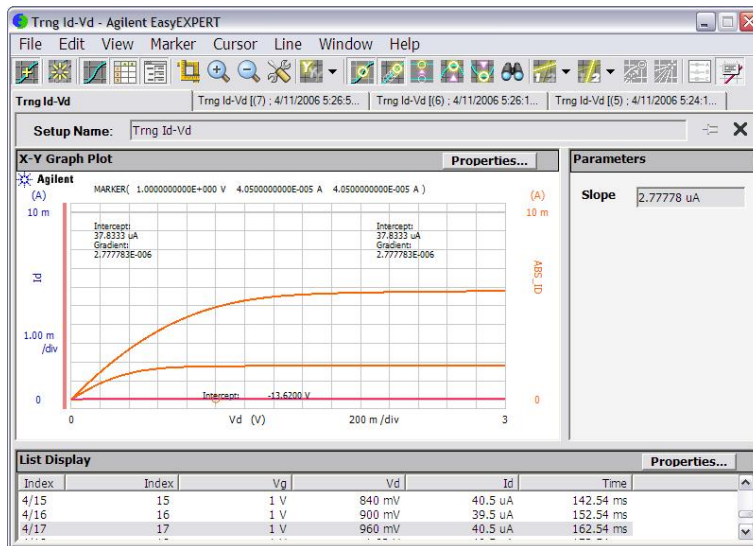

This is a test result example displayed on the Data Display window.

Multi Channel I/V Sweep

- **To Define Channel Setup Screen**
- **To Set VAR1 Sweep Sources**
- **To Set Constant Output**
- **Other Measurement Setup Parameters**
- **To Set User Functions**
- **To Set Data Display**



Multi
Channel I/V
Sweep

This section explains how to perform the Multi Channel I/V sweep measurement. You will perform the above tasks to execute the Multi Channel I/V sweep measurement.

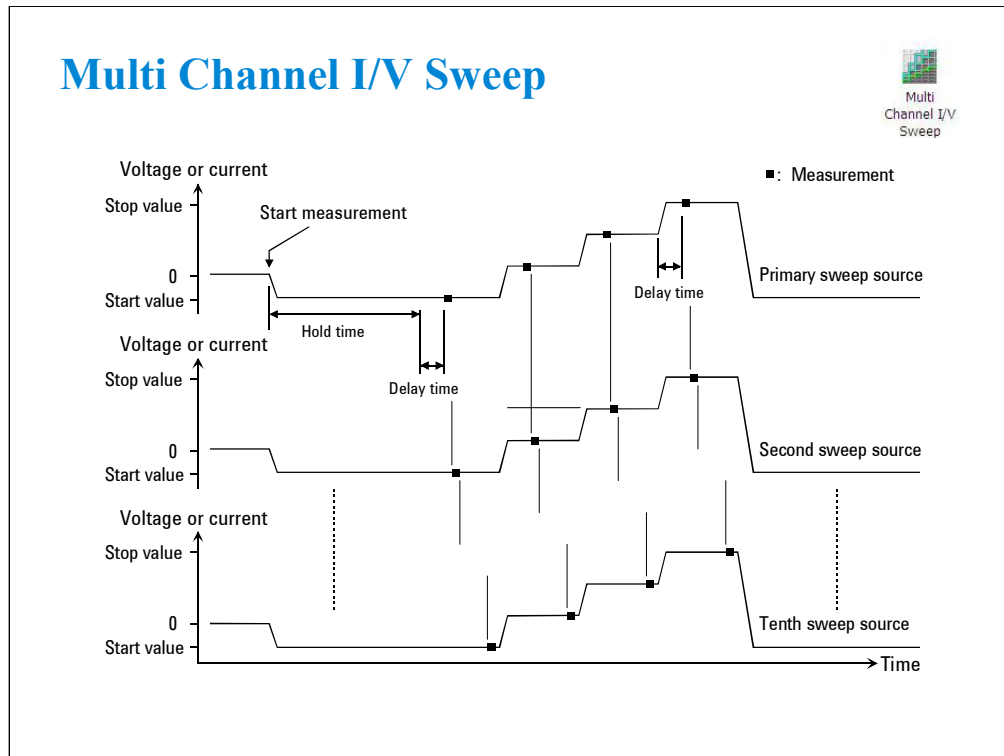

Multi Channel I/V Sweep measurement is similar to I/V Sweep measurement.

Changes from I/V Sweep are listed below.

- All SMU can be set to the VAR1 sweep source (up to 10 channels)
- All SMU can be set to the pulse output mode
- Both voltage mode and current mode are available for the VAR1 sweep output
- VAR1' sweep output is not available

The output channels start to output in the order in which they are listed on the Channel Setup screen.

If multiple pulse output channels are used, the DC output channels start to output in the order in which they are listed on the Channel Setup screen, and then the pulse output channels start to output simultaneously. And the all measurement channels perform measurements simultaneously.

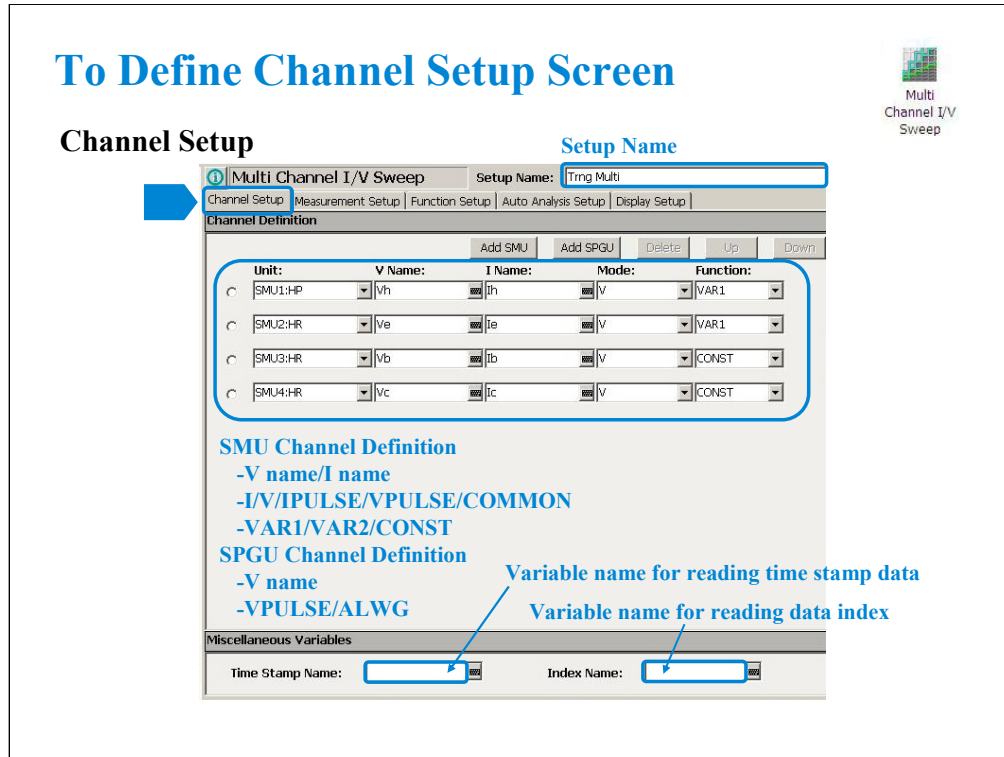

Click the Multi Channel I/V Sweep icon and open the setup editor. Then click the Channel Setup tab to display the channel definition screen.

1. Enter the Setup Name for the test setup to be defined on the setup editor.
2. List SMUs used for source output or measurement, and set the following parameters.
 - Unit: SMU name or number. The GNDU (ground unit) can be set instead of a SMU.
 - V Name: Variable name for the voltage measurement or source data
 - I Name: Variable name for the current measurement or source data
 - Mode: Source output mode, V (voltage), I (current), VPULSE (voltage pulse), IPULSE (current pulse), or COMMON (ground)
 - Function: Source output function, VAR1 (primary sweep), VAR2 (secondary sweep), CONST (constant). Up to 10 sources can be set to VAR1.

V Name and I Name are used to specify the parameters displayed on the Data Display window. The display parameters are selected on the Display Setup tab screen. For the GNDU, 0 V is returned to the V variable and no data is returned to the I variable.

To use the SPGU channels, click the Add SPGU button. The SPGU channel setup row will appear. Then set the following parameters.

- Unit: SPGU name or number
- V Name: Variable name for the voltage data. No data is returned to the variable.
- Mode: SPGU output mode. VPULSE (voltage pulse) or ALWG (arbitrary linear waveform voltage) for all SPGU.

You can read measurement data by using the Data Display window. Parameters displayed on the window are selected on the Display Setup tab screen. If you enter the variable name in the V Name, I Name, Time Stamp Name, and/or Index Name entry fields, you can choose the variables as the display parameters.

Note: The time stamp is the time the measurement is started for each measurement point. The index is the index number for each measurement data.

To Set VAR1 Sweep Sources

Measurement Setup

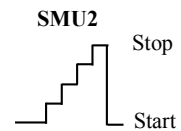
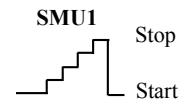
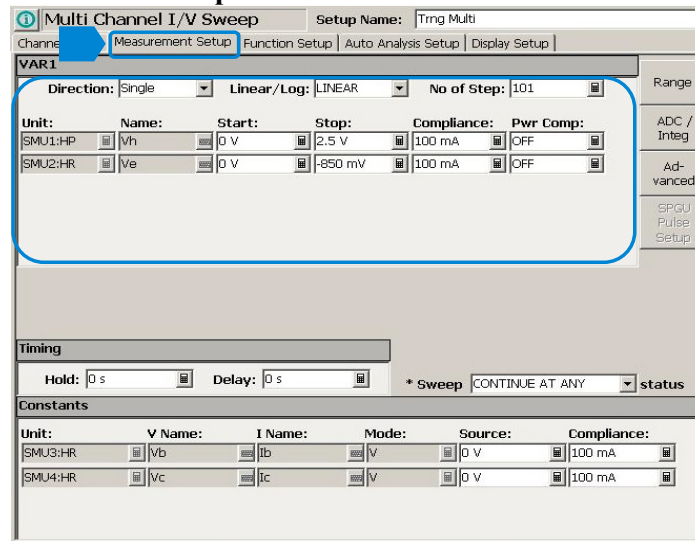

The Measurement Setup tab screen is used to set the source output value and timing parameters.

At the VAR1 area, you set VAR1 sweep sources.

Follows are common parameters for all VAR1 sweep sources.

- Direction: Single (start to stop) or Double (start to stop to start)
- Linear/Log: Linear sweep or Log sweep
- No of Step: Number of sweep steps

Following parameters can be set for each VAR1 sweep sources.

- Unit: SMU name or number
- Name: Variable name of source output
- Start: Source output start value
- Stop: Source output stop value
- Compliance: SMU compliance value
- Pwr Comp: SMU power compliance value

To Set Constant Output

Measurement Setup



Multi Channel I/V Sweep Setup Name: Trng Multi

Channel: Measurement Setup Function Setup Auto Analysis Setup Display Setup

VARI

Direction: Single Linear/Log: LINEAR No of Step: 101

Unit:	Name:	Start:	Stop:	Compliance:	Pwr Comp:
SMU1:HP	Vh	0 V	2.5 V	100 mA	OFF
SMU2:HR	Ve	0 V	-850 mV	100 mA	OFF

Timing

Hold: 0 s Delay: 0 s * Sweep CONTINUE AT ANY status

Constants

Unit:	V Name:	I Name:	Mode:	Source:	Compliance:
SMU3:HR	Vb	Ib	V	0 V	100 mA
SMU4:HR	Vc	Ic	V	0 V	100 mA

At the Constants area, you set the SMU constant output.

- Unit: SMU name or number
- V Name: Variable name for the voltage measurement or source data
- I Name: Variable name for the current measurement or source data
- Mode: Source output mode, V (voltage), I (current), or COMMON (ground)
- Source: SMU output value
- Compliance: SMU compliance value

Other Measurement Setup Parameters



Measurement Setup

Multi Channel I/V Sweep Setup Name: Trng Multi

Channel: Measurement Setup Function Setup Auto Analysis Setup Display Setup

VAR1

Direction: Single Linear/Log: LINEAR No of Step: 101

Unit:	Name:	Start:	Stop:	Compliance:	Pwr Comp:
SMU1:HP	Vh	0 V	2.5 V	100 mA	OFF
SMU2:HR	Ve	0 V	-850 mV	100 mA	OFF

Timing

Hold: 0 s Delay: 0 s * Sweep CONTINUE AT ANY status

Constants

Unit:	V Name:	I Name:	Mode:	Source:	Compliance:
SMU3:HR	Vb	Ib	V	0 V	100 mA
SMU4:HR	Vc	Ic	V	0 V	100 mA



For the functions of Timing, Sweep status, Range, ADC/Integ, Advanced, SPGU Pulse Setup, and SPGU ALWG Setup, see the following pages respectively in the I/V Sweep section of this module.

- To Set Timing Parameters
- To Set Sweep Abort Function
- To Set Ranging Mode
- To Set ADC/Integration Time
- Advanced Setup
- SPGU Pulse Setup
- SPGU ALWG Setup

If a SMU is set to the pulse output:

The Range button is not available.

The dialog box opened by the ADC/Integ button is different from the I/V Sweep. See “A/D Converter & Integration Time Setting” page.

The Pulse button is available which opens the Pulse Setup dialog box. See “Pulse Setup” page.

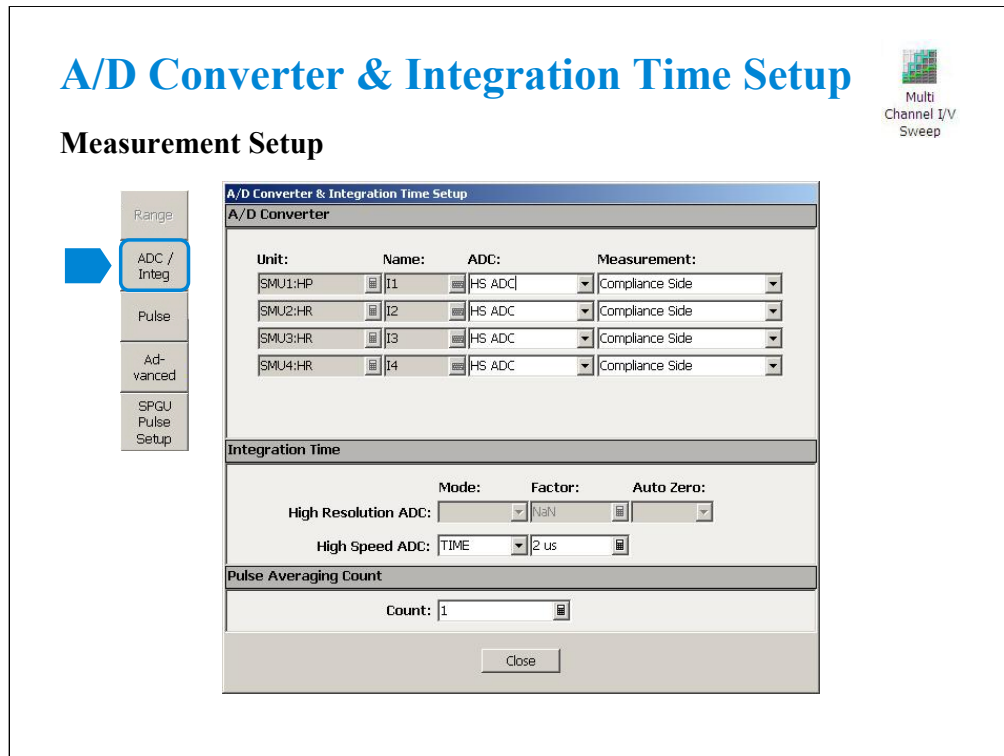

The ADC/Integ button opens the A/D Converter & Integration Time Setup dialog box. The dialog box is used to set the operation of the high speed ADC.

A/D Converter:

- Unit: SMU name or number
 - Name: Variable name of the measurement data
 - ADC: ADC type, HS ADC (high speed)
 - Measurement: Compliance side measurement or Force and Compliance sides measurement.
- HR ADC is not available for HCSMU, HVSMU, and the measurement which uses SMU pulse.
Force and Compliance sides measurement is not available for HRSMU, MPSMU, and HPSMU.

Integration Time:

- Mode: ADC operation mode TIME or PLC.
- Factor: Coefficient for the reference value of the integration time.

Pulse Averaging Count:

- Count: Number of pulsed measurements for averaging to get one measurement data. Not effective for HRSMU, MPSMU, and HPSMU. The setting is automatically set to the same setting on the Pulse Setup dialog box for using multiple SMU pulse output channels.

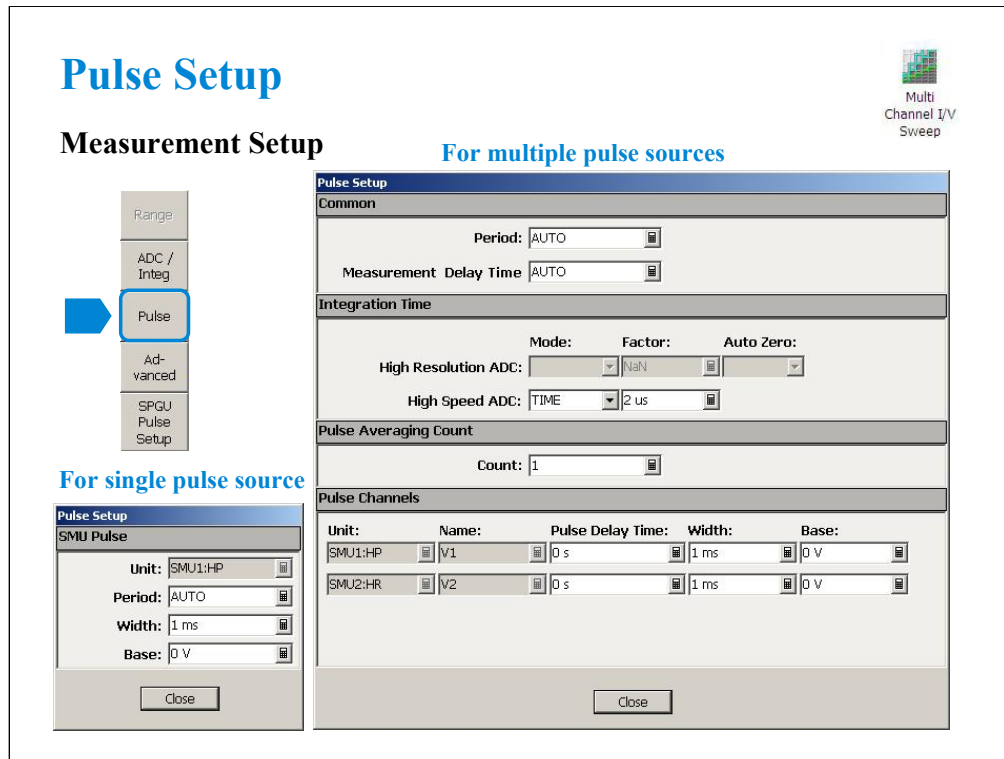

Common:

- Period: Pulse period. Entering AUTO sets the optimum value automatically.
- Measurement Delay Time: Delay time from the beginning of the pulse period to the beginning of the measurement. Entering AUTO sets the optimum value automatically so that the measurement is completed when the transition from peak to base is started by the pulse output channel which starts the transition at first.

Integration Time:

- Mode: ADC operation mode TIME or PLC.
- Factor: Coefficient for the reference value of the integration time.

Pulse Averaging Count:

- Count: Number of pulsed measurements for averaging to get one measurement data. Not effective for HRSMU, MPSMU, and HPSMU.

The Integration Time and Count settings are automatically set to the same settings on the A/D Converter & Integration Time Setup dialog box.

Pulse Channels:

- Pulse Delay Time: Delay time from the beginning of the pulse period to the beginning of the transition from base to peak. This value must be 0 for HRSMU, MPSMU, and HPSMU.
- Width Pulse width. The value must be the same for HRSMU, MPSMU, and HPSMU.
- Base: Pulse base value

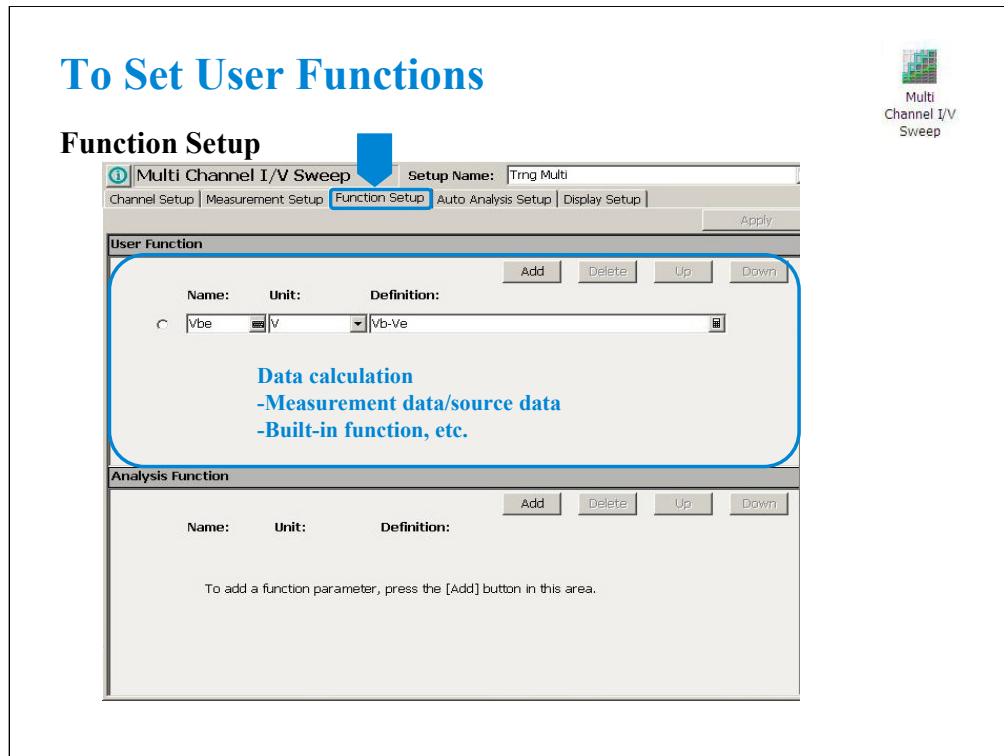

Click the Function Setup tab to display the User Function/Analysis Function setup screen. The user functions can be displayed on the X-Y Graph Plot, List Display, and Parameters area of the Data Display window. Up to 20 functions can be set.

Name: Function name

Unit: Unit of the function

Definition: Definition of the function. The following identifiers can be used.

-Variables for the measurement/output data used in this test

-Functions defined in the above lines

-Local variables passed from the application test that calls this test as a component

-Built-in functions and global variables

For details, see online help or User's Guide.

To Set Data Display

Display Setup

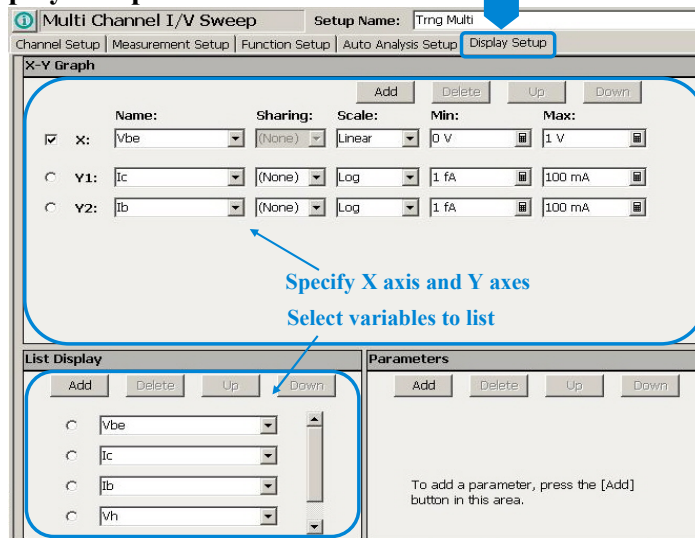

Specify X axis and Y axes
Select variables to list

Click the Display Setup tab to display the display setup screen.

The X-Y Graph area is used to set the X axis and Y axes of the X-Y Graph Plot area in the Data Display window.

- Name: Name of variable to plot on the X axis
- Scale: Linear or Log
- Min: Minimum value of the specified axis
- Max: Maximum value of the specified axis

The List Display area selects the variables to be listed in the List Display area of the Data Display window. Up to 20 variables can be set.

For example, following variables are set for the Class Exercise.

Vbe, Ic, Ib, Vh, Ih

Class Exercise



Define test setup and perform test.

1. **Click Multi Channel I/V Sweep icon and open setup editor.**
2. **Define test setup as shown in the previous pages.**
3. **Save it as Trng Multi.**
4. **Connect devices (NPN Bipolar Transistor and Red Miniature LED) as shown in next several pages, and perform test.**
5. **Export preset group, and import it.**

Note:

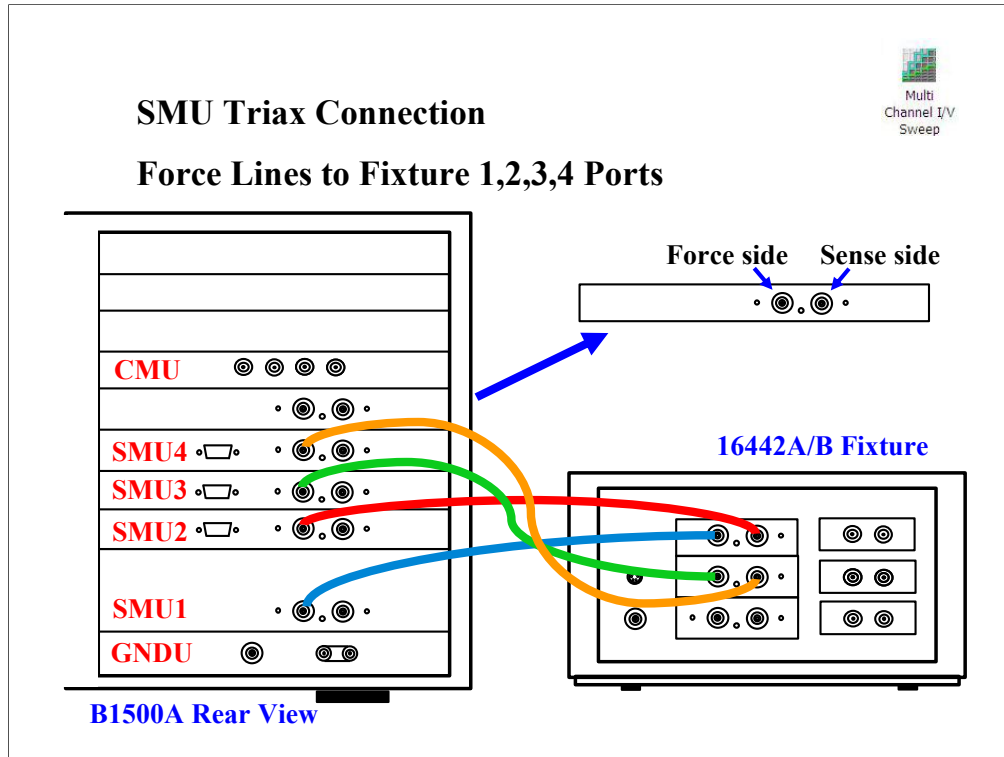

For the non-Kelvin connections, connect only the Force lines, leaving the Sense lines open.

Connect corresponding numbers. On the 16442A/B fixture use the numbers labeled 1 - 6, not 1 - 3.

Your B1500 may not match the SMU configuration shown in this figure. Note that SMU1 is the module top of the GNDU (ground unit). The SMU number become large from bottom to top as shown.

This is the SMU cable setup that will be used in the remainder of the class exercises.

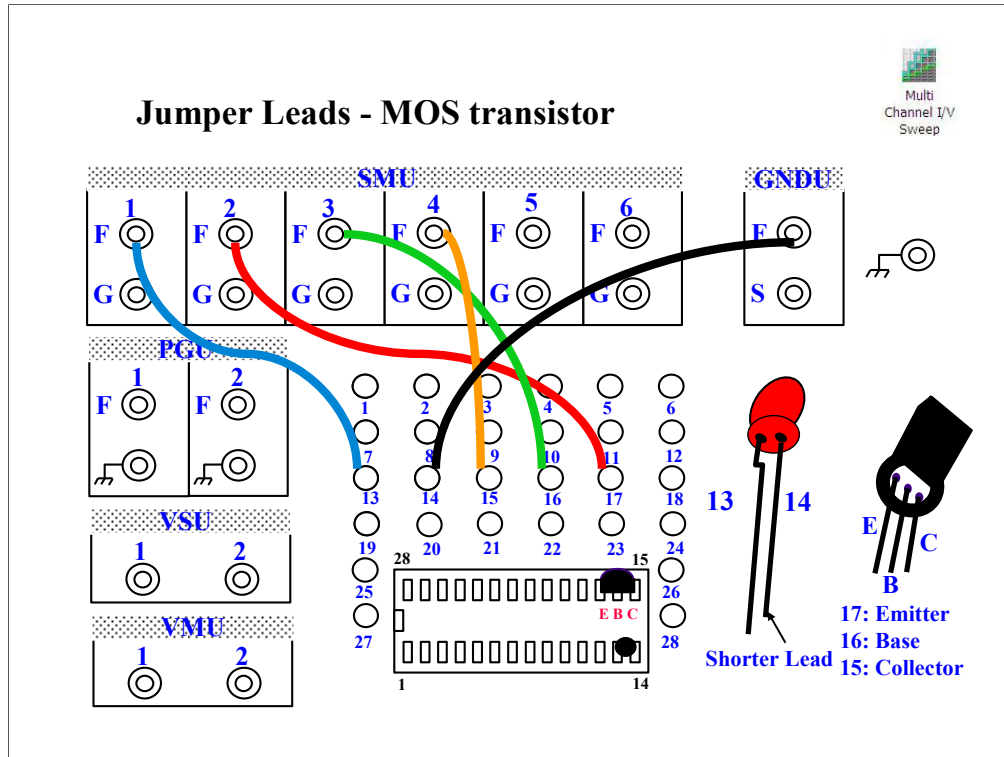

With the 16442A/B fixture, note that there are two SMU numbering schemes....3 SMUs with force and sense, or six SMUs with force only. For this class example we will use the six (6) SMU scheme.

Connect jumper leads as follows.

- Terminal 13 : SMU1 F terminal
- Terminal 14 : GNDU F terminal
- Terminal 15 : SMU4 F terminal
- Terminal 16 : SMU3 F terminal
- Terminal 17 : SMU2 F terminal

Locate the bipolar transistor in the corner of the 28-pin dual in line socket as shown, with the flat side of the device facing toward you. Unlike the MOS device, the bipolar transistor is not static sensitive. You may touch the leads without using a ground strap.

Locate the LED between terminals 13 and 14 of the 28-pin dual in line socket.

Measurement Result Example

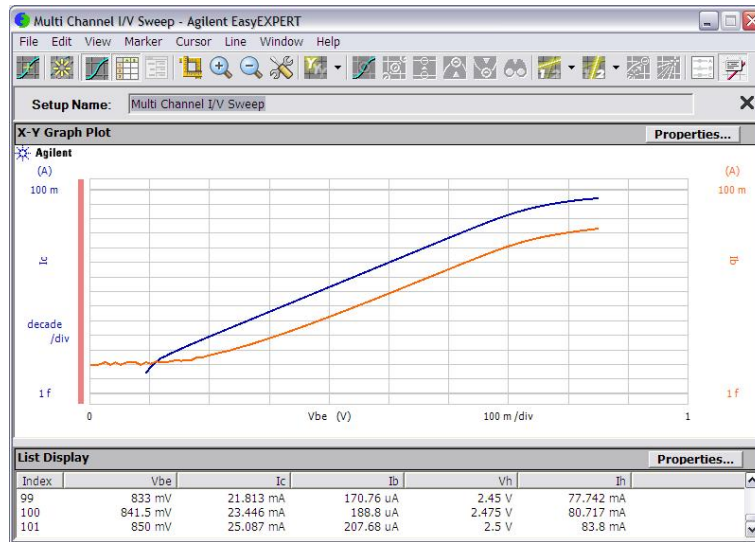

This is a test result example displayed on the Data Display window.

At the start of measurement, LED lights off. Beyond the threshold voltage, the LED lights on.

I/V List Sweep



- **To Define Channel Setup Screen**
- **To Set VAR1 Sweep Sources**
- **To Set Constant Output**
- **Other Measurement Setup Parameters**
- **To Set User/Analysis Functions**
- **Auto Analysis Setup**
- **To Set Data Display**

This section explains how to perform I/V List sweep measurement. You will perform the above tasks to execute the I/V List sweep measurement.

I/V List Sweep measurement is similar to I/V Sweep measurement.

Changes from the I/V Sweep are listed below.

- VAR1/VAR2 step output values are set by using a vector data. Vector data from a spreadsheet software, either tab separated or comma separated can be copied to the Define vector data dialog box via the Windows clipboard.
- All SMU installed in the B1500 can be set to VAR1.
- VAR1' is not supported.

For more information, see online help or User's Guide.

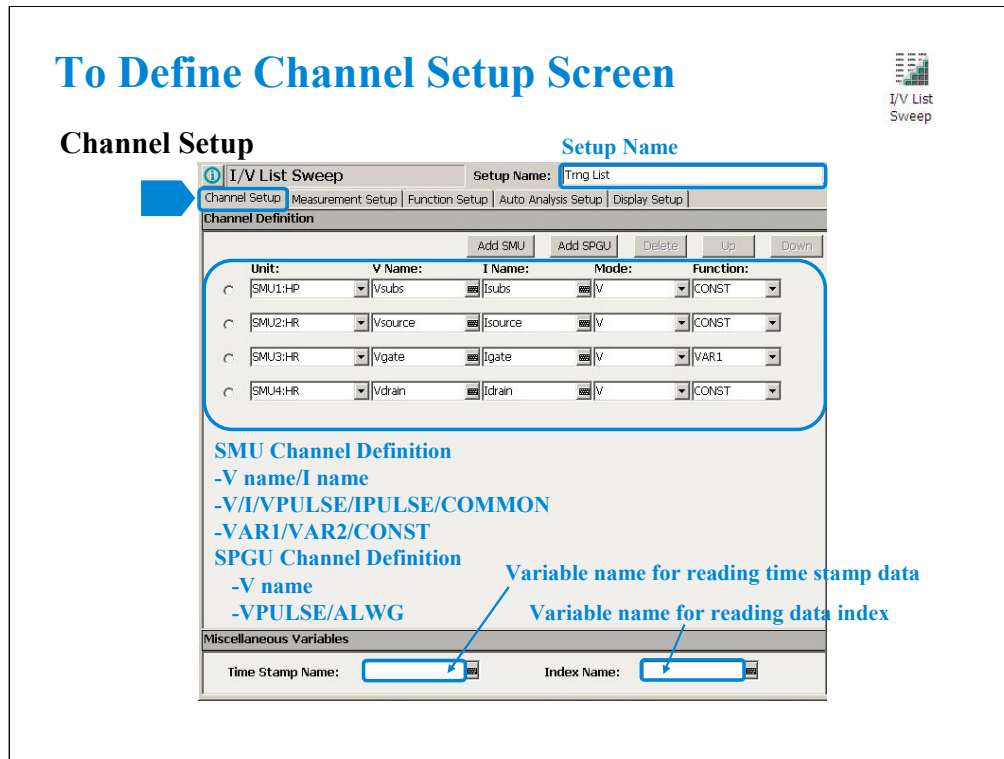

Click the I/V List Sweep icon and open the setup editor. Then click the Channel Setup tab to display the channel definition screen.

1. Enter the Setup Name for the test setup to be defined on the setup editor.
2. List SMUs used for source output or measurement, and set the following parameters.
 - Unit: SMU name or number. The GNDU (ground unit) can be set instead of a SMU.
 - V Name: Variable name for the voltage measurement or source data
 - I Name: Variable name for the current measurement or source data
 - Mode: Source output mode, V (voltage), I (current), VPULSE (voltage pulse), IPULSE (current pulse), or COMMON (ground)
 - Function: Source output function, VAR1 (primary sweep), VAR2 (secondary sweep), or CONST (constant). Note: Up to 10 sources can be set to VAR1.

V Name and I Name are used to specify the parameters displayed on the Data Display window. The display parameters are selected on the Display Setup tab screen. For the GNDU, 0 V is returned to the V variable and no data is returned to the I variable.

To use the SPGU channels, click the Add SPGU button. The SPGU channel setup row will appear. Then set the following parameters.

- Unit: SPGU name or number
- V Name: Variable name for the voltage data. No data is returned to the variable.
- Mode: SPGU output mode. VPULSE (voltage pulse) or ALWG (arbitrary linear waveform voltage) for all SPGU.

You can read measurement data by using the Data Display window. Parameters displayed on the window are selected on the Display Setup tab screen. If you enter the variable name in the V Name, I Name, Time Stamp Name, and/or Index Name entry fields, you can choose the variables as the display parameters.

Note: The time stamp is the time the measurement is started for each measurement point. The index is the index number for each measurement data.

To Set VAR1 Sweep Sources



Measurement Setup

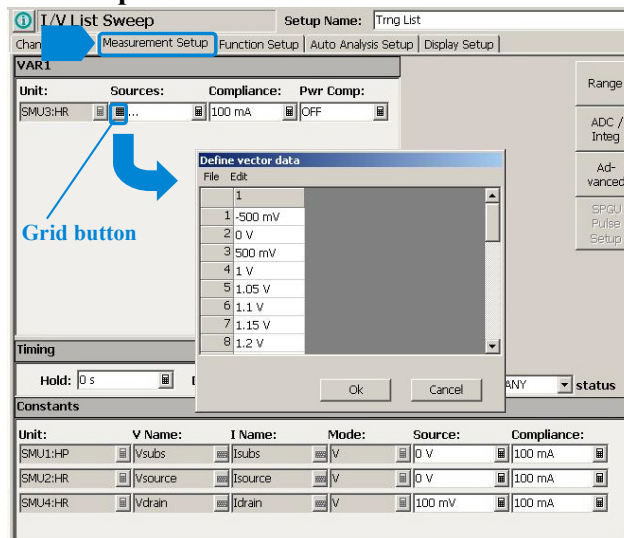

The Measurement Setup tab screen is used to set the source output value and timing parameters.

At the VAR1 area, you set VAR1 sweep sources.

- Unit: SMU name or number
- Source: Click the grid button to open the Define vector data dialog box. Enter the vector data of VAR1. For example, -500 m, 0, 500 m, 1, 1,05,1.1, 1.15, 1.2, 1.25, 1.3, 1.35, 1.4, 1.45, 1.5, 1.55, 1.6, 1.65, 1.7, 1.75, 1.8, 1.85, 1.9, 1.95, 2, 2.5, and 3 V are set for the Vth-gmMax. Step voltages near the gmMax are set to 50 mV and others are set to 500 mV.
- Compliance: SMU compliance value
- Pwr Comp: SMU power compliance value

To Set Constant Output

Measurement Setup



I/V List Sweep Setup Name: Trng List

Chan: Measurement Setup Function Setup Auto Analysis Setup Display Setup

VAR1

Unit:	Sources:	Compliance:	Pwr Comp:	Range
SMU3:HR	...	100 mA	OFF	ADC / Integ

Advanced
SPGU Pulse Setup

Timing

Hold: 0 s Delay: ... * Sweep CONTINUE AT ANY status

Constants

Unit:	V Name:	I Name:	Mode:	Source:	Compliance:
SMU1:HP	vsubs	isubs	V	0 V	100 mA
SMU2:HR	vsource	isource	V	0 V	100 mA
SMU4:HR	vdrain	idrain	V	100 mV	100 mA

At the Constants area, you set the SMU constant output.

- Unit: SMU name or number
- V Name: Variable name for the voltage measurement or source data
- I Name: Variable name for the current measurement or source data
- Mode: Source output mode, V (voltage), I (current), VPULSE (voltage pulse), IPULSE (current pulse), or COMMON (ground)
- Source: SMU output value. For example, Vdrain is set to 100 mV for the Vth-gmMax.
- Compliance: SMU compliance value

Other Measurement Setup Parameters



Measurement Setup

Unit:	Sources:	Compliance:	Pwr Comp:
SMU3:HR	...	100 mA	OFF

Unit:	V Name:	I Name:	Mode:	Source:	Compliance:
SMU1:HP	vsubs	isubs	V	0 V	100 mA
SMU2:HR	vsource	isource	V	0 V	100 mA
SMU4:HR	vdrain	idrains	V	100 mV	100 mA

For the functions of Timing, Sweep status, Range, ADC/Integ, Advanced, SPGU Pulse Setup, and SPGU ALWG Setup, see the following pages respectively in the I/V Sweep section of this module.

- To Set Timing Parameters
- To Set Sweep Abort Function
- To Set Ranging Mode
- To Set ADC/Integration Time
- Advanced Setup
- SPGU Pulse Setup
- SPGU ALWG Setup

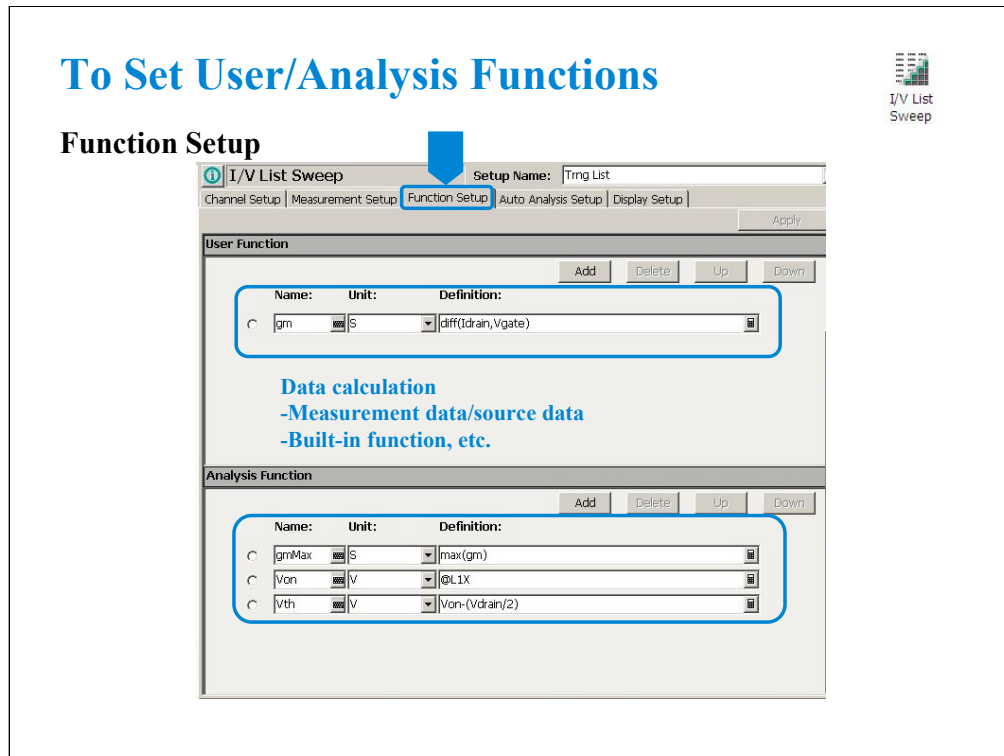

Click the Function Setup tab to display the User Function/Analysis Function setup screen. The user/analysis functions can be displayed on the X-Y Graph Plot, List Display, and Parameters area of the Data Display window. Up to 20 functions can be set.

Name: Function name

Unit: Unit of the function

Definition: Definition of the function. The following identifiers can be used.

- Variables for the measurement/output data used in this test
- Functions defined in the above lines
- Local variables passed from the application test that calls this test as a component
- Built-in functions and global variables

For details, see online help or User's Guide.

For example, following user/analysis functions are set for the Vth-gmMax.

<Name> <Unit> <Definition>

Gm S diff(Idrain,Vgate)

gmMax S max(gm)

Von V @L1X

Vth V Von-(Vdrain/2)

For built-in functions, see online help or User's Guide.

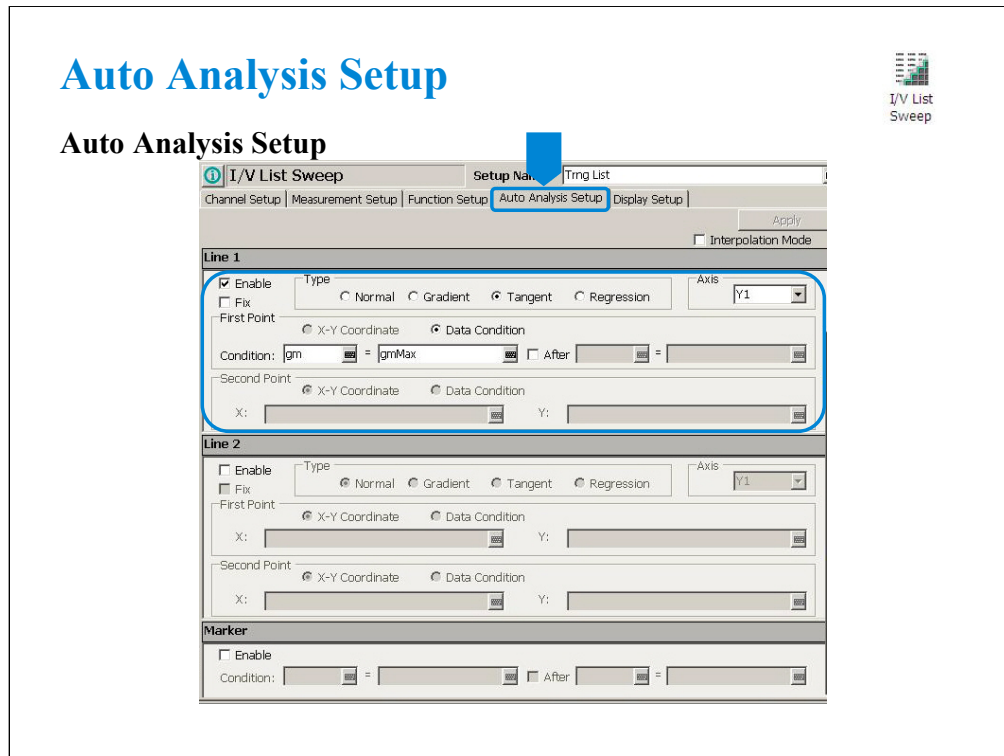

Click the Auto Analysis Setup tab to display the Auto Analysis setup screen. This screen is used to set the automatic analysis function. When a measurement finishes, the function automatically draws lines, a marker, or both on the X-Y Graph of the Data Display window.

You can set up two lines and one marker for the automatic analysis function.

In the Line 1 and Line 2 areas, you can set up the lines to be drawn.

In the Marker area, you can set up the marker.

For details, see online help or User's Guide.

For example, the Line 1 is set for the V_{th} -gmMax.

Type: Tangent

Axis: Y1

First Point: Data Condition

Condition: $gm = gmMax$

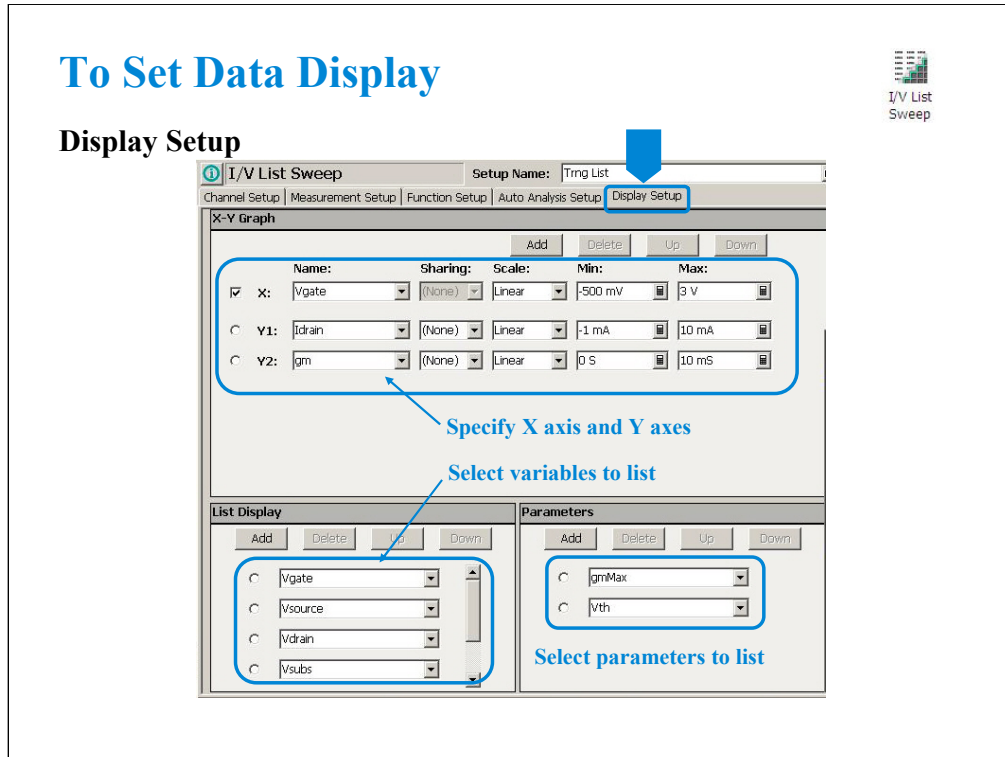

Click the Display Setup tab to display the display setup screen.

The X-Y Graph area is used to set the X axis and Y axes of the X-Y Graph Plot area in the Data Display window.

- Name: Name of variable to plot on the X axis
- Scale: Linear or Log
- Min: Minimum value of the specified axis
- Max: Maximum value of the specified axis

For example, following axes are set for the Vth-gmMax.

	<Name>	<Sharing>	<Scale>	<Min>	<Max>
X	Vgate		Linear	-500 mV	3 V
Y1	Idrain	(None)	Linear	-1 mA	10 mA
Y2	gm	(None)	Linear	0 S	10 mS

The List Display area selects the variables to be listed in the List Display area of the Data Display window. Up to 20 variables can be set.

For example, following variables are set for the Vth-gmMax.

Vgate, Vsource, Vdrain, Vsubs, Idrain, gm

The Parameters area selects the variables to be listed in the Parameters area of the Data Display window. Up to 20 parameters can be set.

For example, following parameters are set for the Vth-gmMax.

gmMax, Vth

Class Exercise



Define test setup and perform test.

1. **Click I/V List Sweep icon and open setup editor.**
2. **Define test setup as shown in the previous pages.**
3. **Save it as Trng List.**
4. **Connect an N-ch MOSFET as shown in next several pages, and perform test.**
5. **Export preset group, and import it.**

Note:

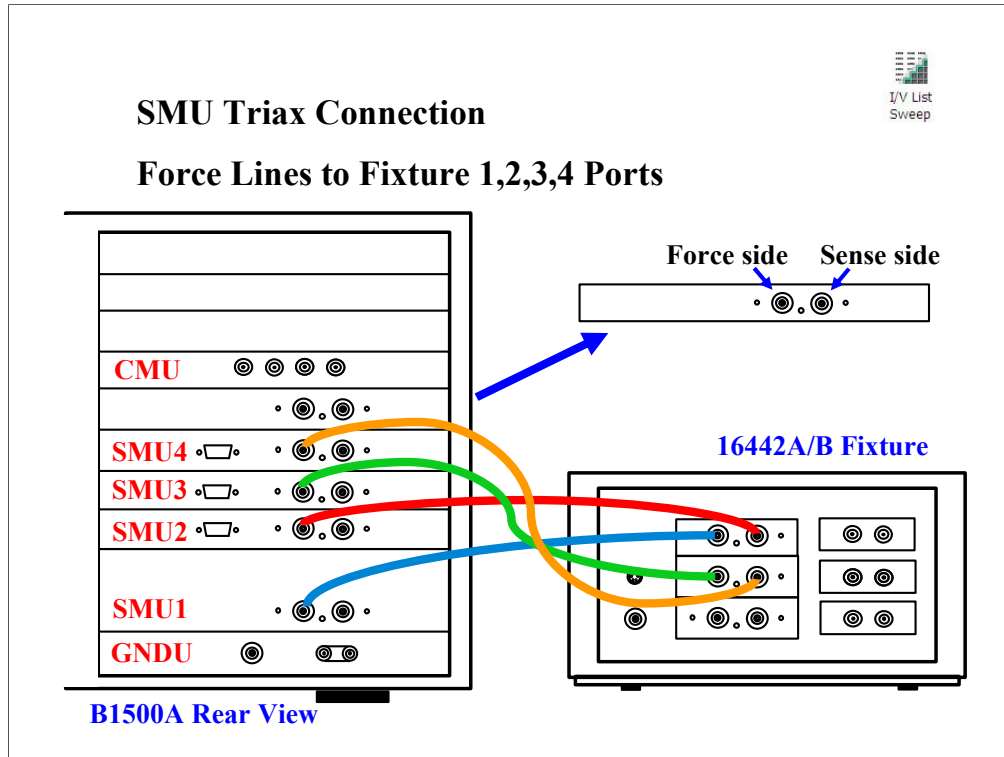

For the non-Kelvin connections, connect only the Force lines, leaving the Sense lines open.

Connect corresponding numbers. On the 16442A/B fixture use the numbers labeled 1 - 6, not 1 - 3.

Your B1500 may not match the SMU configuration shown in this figure. Note that SMU1 is the module top of the GNDU (ground unit). The SMU number become large from bottom to top as shown.

This is the SMU cable setup that will be used in the remainder of the class exercises.

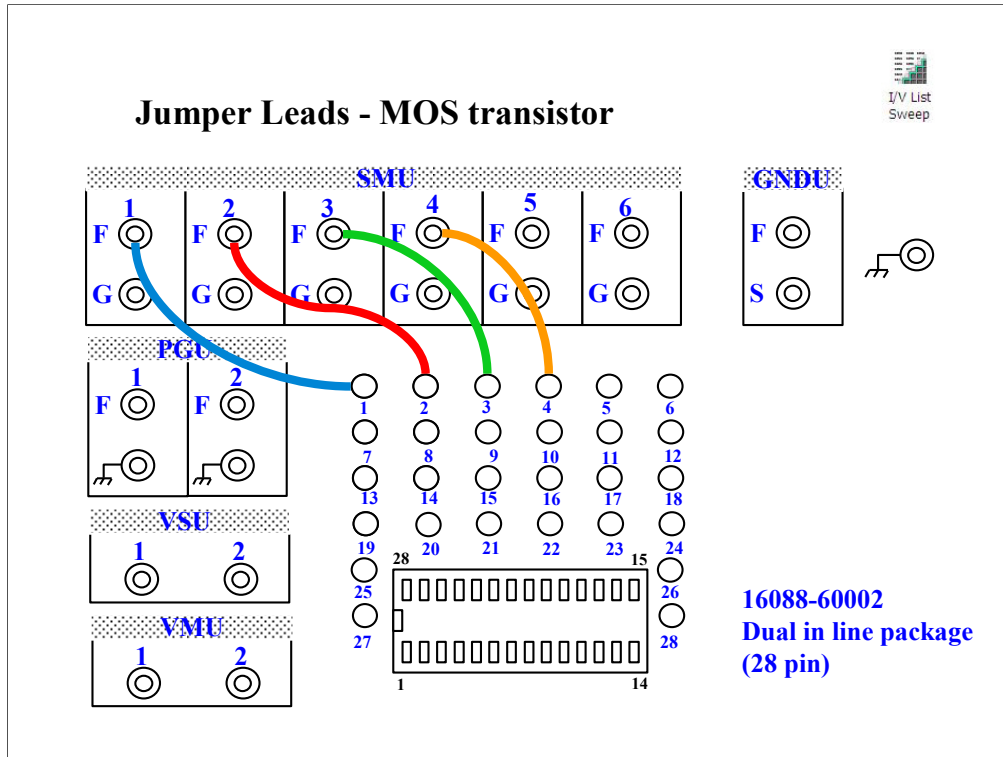

With the 16442A/B fixture, note that there are two SMU numbering schemes...3 SMUs with force and sense, or six SMUs with force only. For this class example we will use the six (6) SMU scheme. On older fixtures, this scheme is shown in light blue lettering. In newer fixtures, this scheme is shown in white reverse background lettering.

Device Orientation and Insertion

I/V List
Sweep



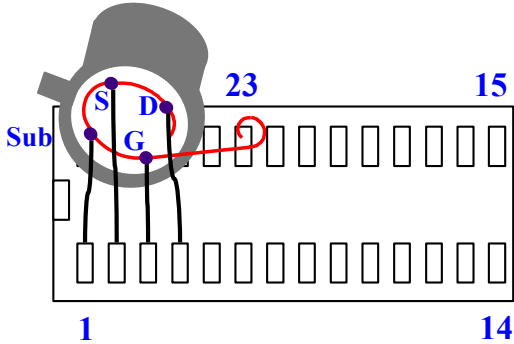

Insert the transistor last, AFTER connecting the cables and leads. Remove the shorting wire after insertion in the socket.

- 1: Substrate
- 2: Source
- 3: Gate
- 4: Drain

The MOS FET leads must be re-arranged into a straight line as shown.

IMPORTANT:

The MOS FET is highly sensitive to electrostatic damage. Touching the bare leads can definitely destroy the device. The device comes with a special shorting wire attached. Bend the leads the way you want, insert the device in the socket, and then remove the shorting wire. The wire has a tab. Just grab the tab and pull straight out. The wire will spiral out as you pull.

Once the shorting wire is removed, you must use a wrist strap when handling the device.

Measurement Result Example

I/V List
Sweep

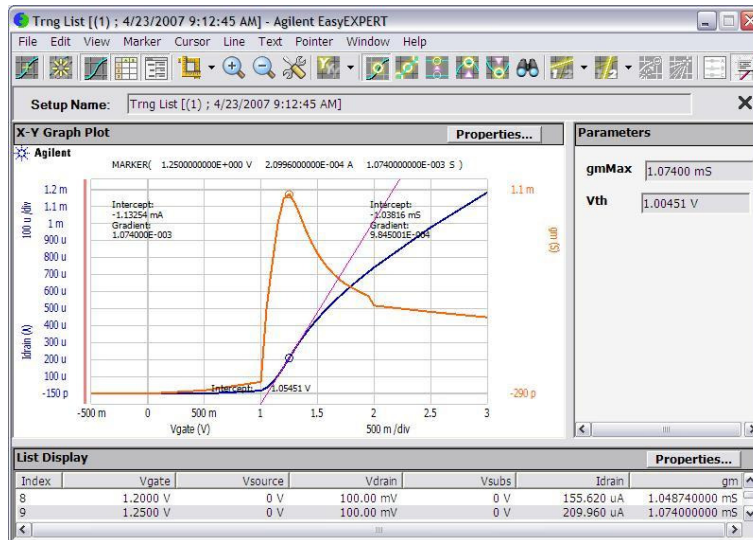

This is a test result example displayed on the Data Display window.

I/V-t Sampling Measurement



I/V-t
Sampling

- To Define Channels and Variables
- To Set Sampling Parameters
- To Set Stop Condition
- To Set SMU Outputs (CONST)
- Range/ADC/Advanced/SPGU
- To Set User Functions/
Analysis Functions
- To Set Data Display

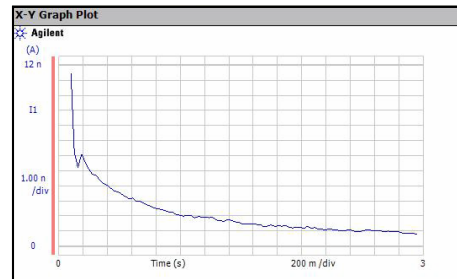

This section explains how to perform I/V-t sampling measurement. You will perform the above tasks to execute the I/V-t sampling measurement.

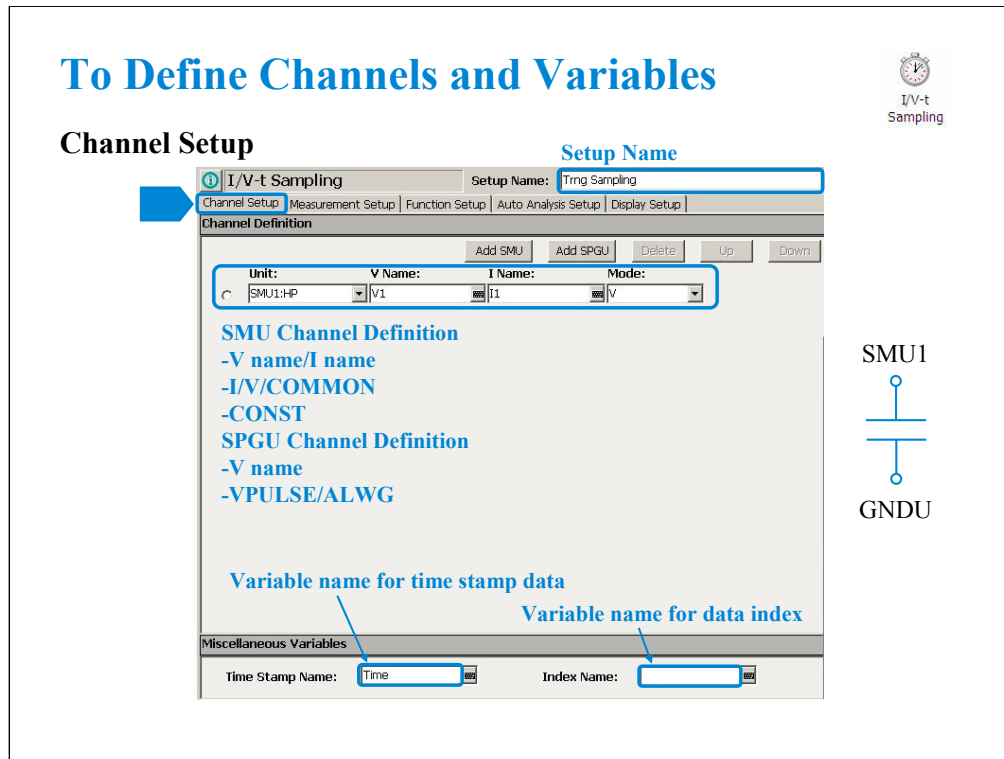

Click the I/V-t Sampling icon and open the setup editor. Then click the Channel Setup tab to display the channel definition screen.

1. Enter the Setup Name for the test setup to be defined on the setup editor.
2. List SMUs used for source output or measurement, and set the following parameters.

- Unit: SMU name or number
- V Name: Variable name for the voltage measurement or source data
- I Name: Variable name for the current measurement or source data
- Mode: Source output mode, V (voltage), I (current), or COMMON (ground)
- Time Stamp Name: Variable name for the time stamp data
- Index Name: Variable name for the data index

V Name and I Name are used to specify the parameters displayed on the Data Display window. The display parameters are selected on the Display Setup tab screen. For the GNDU, 0 V is returned to the V variable and no data is returned to the I variable.

To use the SPGU channels, click the Add SPGU button. The SPGU channel setup row will appear. Then set the following parameters.

- Unit: SPGU name or number
- V Name: Variable name for the voltage data. No data is returned to the variable.
- Mode: SPGU output mode. VPULSE (voltage pulse) or ALWG (arbitrary linear waveform voltage) for all SPGU.

You can read measurement data by using the Data Display window. Parameters displayed on the window are selected on the Display Setup tab screen. If you enter the variable name in the V Name, I Name, Time Stamp Name, and/or Index Name entry fields, you can choose the variables as the display parameters.

Note: The time stamp is the time the measurement is started for each measurement point. The index is the index number for each measurement data.

To Set Sampling Parameters

Measurement Setup

I/V-t
Sampling

Channel Setup | Measurement Setup | Function Setup | Auto Analysis Setup | Display Setup

Setup Name: Trng Sampling

Sampling Parameter

Linear/Log: LINEAR
Interval: 30 ms
No of Samples: 101
Total Sampling Time: 3 s
Output Sequence: SEQUENTIAL
Hold Time: 100 ms
Base Hold Time: 0 s

Stop Condition

Enable/Disable: ENABLE
Enable Delay: 0 s
Name: I1
Threshold: 0 A
Event: Val < Th
No. of Events: 1

Constants

Unit:	V Name:	I Name:	Mode:	Base:	Source:	Compliance:
SMU1:HP	V1	I1	V	0 V	5 V	100 mA

Trigger
Measurement time
Hold time
Sampling interval

Click the Measurement Setup tab to display the setup screen for the sampling timing parameters and the SMU source output parameters. At the Sampling Parameter area, you set the following sampling timing parameters.

Linear/Log:

Sampling mode. LINEAR for linear sampling. LOG10, LOG25, LOG50, LOG100, LOG250, or LOG500 for logarithmic sampling. For the logarithmic sampling, the number after LOG indicates the number of measurement data in a decade. For example, LOG10 mode is used to get 10 data/decade.

For the log sampling, the B1500 holds only the data that can be plotted on the log scale in the same distance as close as possible. Only the held data is counted in the number of measurement result data.

For the linear sampling with Interval < 2 ms, if the total measurement time runs over the specified time Interval × No of Samples, the sampling measurement will be stopped even if the number of measurement result data is less than the specified No of Samples.

Interval:

Interval of the sampling, in seconds. 0.002 to 65.535 s, 0.001 s resolution.

Interval < 0.002 s in 0.00001 s resolution is also available for the linear sampling. It must satisfy the following formula. For details, see online help or User's Guide.

Interval ≥ 0.0001 + 0.00002 × (number of measurement channels-1)

To Set Sampling Parameters

Measurement Setup

The screenshot shows the 'I/V-t Sampling' dialog box with the following settings:

- Setup Name: Trng Sampling
- Linear/Log: LINEAR
- Interval: 30 ms
- No of Samples: 101
- Total Sampling Time: 3 s
- Output Sequence: SEQUENTIAL
- Hold Time: 100 ms
- Base Hold Time: 0 s
- Stop Condition: ENABLE
- Enable Delay: 0 s
- Name: I1
- Threshold: 0 A
- Event: Val < Th
- No. of Events: 1

Constants:

Unit:	V Name:	I Name:	Mode:	Base:	Source:	Compliance:
SMU1:HP	V1	I1	V	0 V	5 V	100 mA

No of Samples:

Number of samples. Integer. 1 to the following value.

For linear: $100001 / (\text{number of measurement channels})$

For logarithmic: $1 + (\text{number of data for 11 decades})$

Total Sampling Time:

This field just displays the total sampling time that is the time from the measurement start time for the first point to the end of sampling measurement. It does not include the hold time.

$\text{Total Sampling Time} = \text{Interval} \times \text{No of Samples}$

Output Sequence:

Source output sequence. SIMULTANEOUS or SEQUENTIAL.

Hold Time:

Time since the Source value output until the first sampling point, in seconds. 0 to 655.35 s, resolution 0.01 s.

The following values are also available for Interval < 0.002 s. |Hold Time| will be the time since the sampling start until the Source value output.

-0.09 to -0.0001 s, resolution 0.0001 s.

Base Hold Time:

Hold time of the Base value output until the Source value output, in seconds. 0 to 655.35 s, resolution 0.01 s.

To Set Stop Condition

Measurement Setup

The screenshot shows the 'I/V-t Sampling' Measurement Setup dialog box. The 'Stop Condition' section is highlighted with a blue box. The 'Stop Condition' fields are: Enable/Disable: ENABLE, Enable Delay: 0 s, Name: I1, Threshold: 0 A, Event: Val < Th, and No. of Events: 1. The 'Sampling Parameter' section includes: Linear/Log: LINEAR, Interval: 30 ms, No of Samples: 101, Total Sampling Time: 3 s, Output Sequence: SEQUENTIAL, Hold Time: 100 ms, and Base Hold Time: 0 s. The 'Constants' section includes: Unit: SMU1:HP, V Name: V1, I Name: I1, Mode: V, Base: 0 V, Source: 5 V, and Compliance: 100 mA.

The timing diagram below the dialog shows the sequence of events: Trigger, Hold time, and Sampling interval (which includes Measurement time).

The stop condition is defined by using the Stop Condition fields on the Measurement Setup screen. This function stops the measurement as shown below.

1. Compares the value of parameter set to the Name field and the value defined in the Threshold field.
2. Counts how many times the selected Event occurs.
3. When the count reaches the value defined in the No. of Events field, sampling is stopped immediately.

To Set SMU Outputs (CONST)

Measurement Setup



Unit:	V Name:	I Name:	Mode:	Base:	Source:	Compliance:
SMU1:HP	V1	I1	V	0 V	5 V	100 mA

SMU constant output setup

At the Constants area, you set the SMU constant output.

- Unit: SMU name or number
- V Name: Variable name for the voltage measurement or source data
- I Name: Variable name for the current measurement or source data
- Mode: Source output mode, V (voltage), I (current), or COMMON (ground)
- Base and Source: SMU output value
- Compliance: SMU compliance value

Base value is available for all output channels for the SIMULTANEOUS mode and the last source channel for the SEQUENTIAL mode.

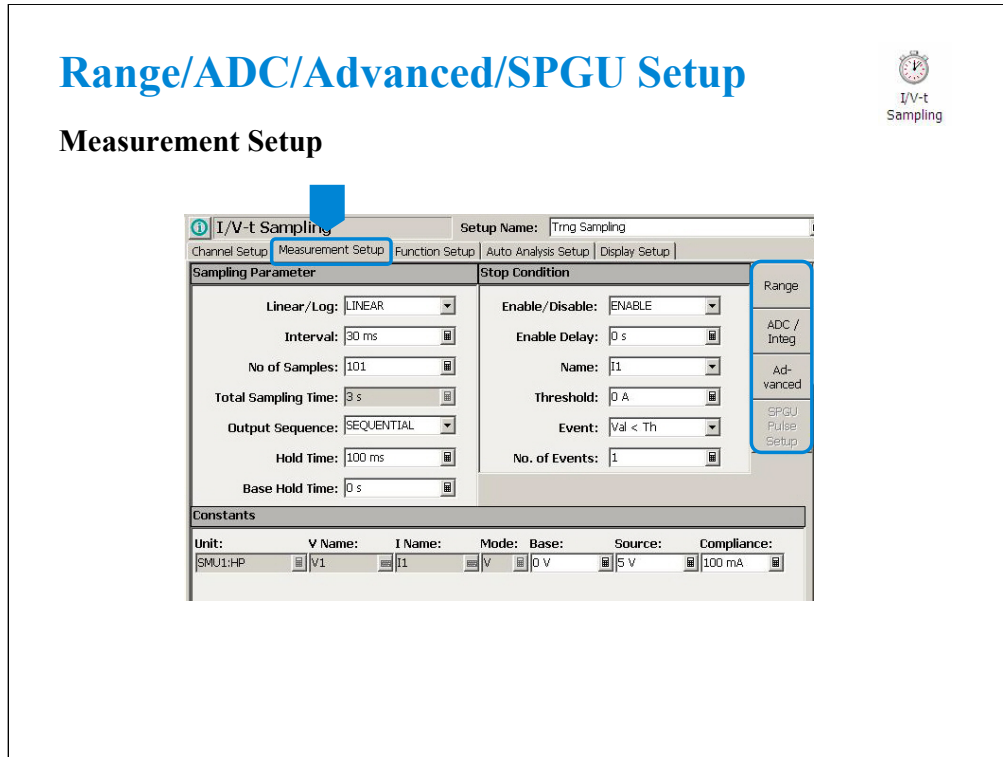

For the Range, ADC/Integ, Advanced, SPGU Pulse Setup, and SPGU ALWG Setup buttons, see the following pages respectively in the I/V Sweep section of this module.

- To Set Ranging Mode
- To Set ADC/Integration Time
- Advanced Setup
- SPGU Pulse Setup
- SPGU ALWG Setup

Note:

If the range changing occurs during measurement, the SMU may not complete measurement within the sampling interval. So use FIXED range if the sampling interval is top priority and the resolution/sensitivity is second priority.

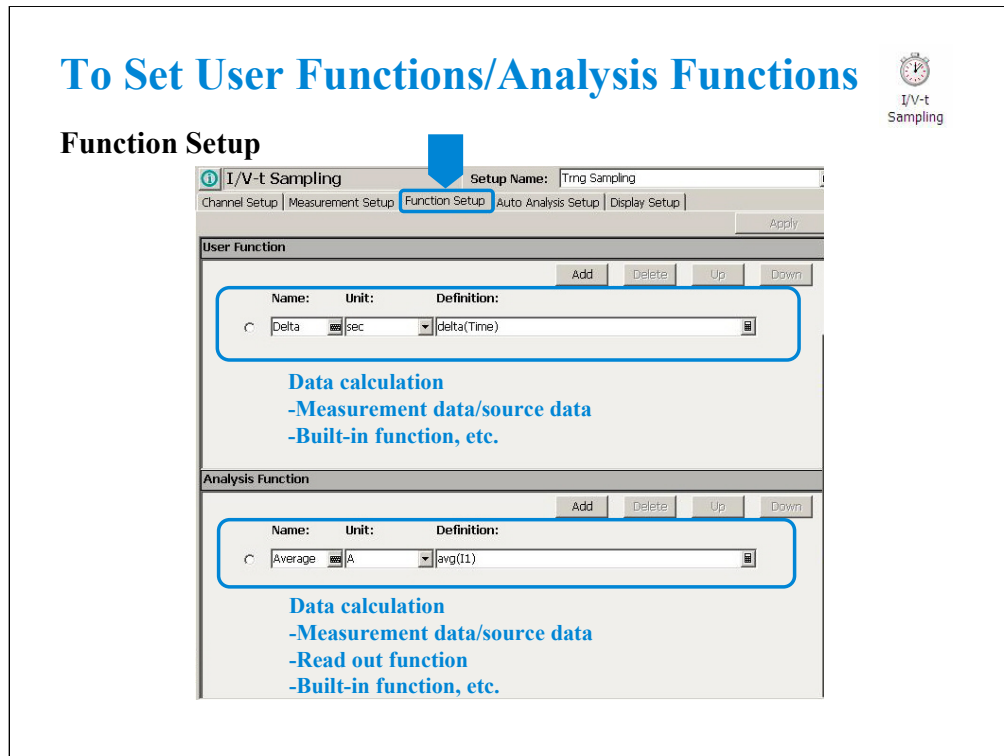

Click the Function Setup tab to display the User Function/Analysis Function setup screen.

The user functions can be displayed on the X-Y Graph Plot, List Display, and Parameters area of the Data Display window. Up to 20 functions can be set.

- Name: Function name
 - Unit: Unit of the function
 - Definition: Definition of the function. The following identifiers can be used.
 - Variables for the measurement/output data used in this test
 - Functions defined in the above lines
 - Local variables passed from the application test that calls this test as a component
 - Built-in functions and global variables
- For details, see online help or User's Guide.

The analysis functions can be displayed on the Parameters area of the Data Display window. Up to 20 functions can be set.

- Name: Function name
 - Unit: Unit of the function
 - Definition: Definition of the function. The following identifiers can be used.
 - Variables for the measurement/output data used in this test
 - Functions defined in the above lines
 - Local variables passed from the application test that calls this test as a component
 - Built-in functions and global variables
 - Read out functions
- For details, see online help or User's Guide.

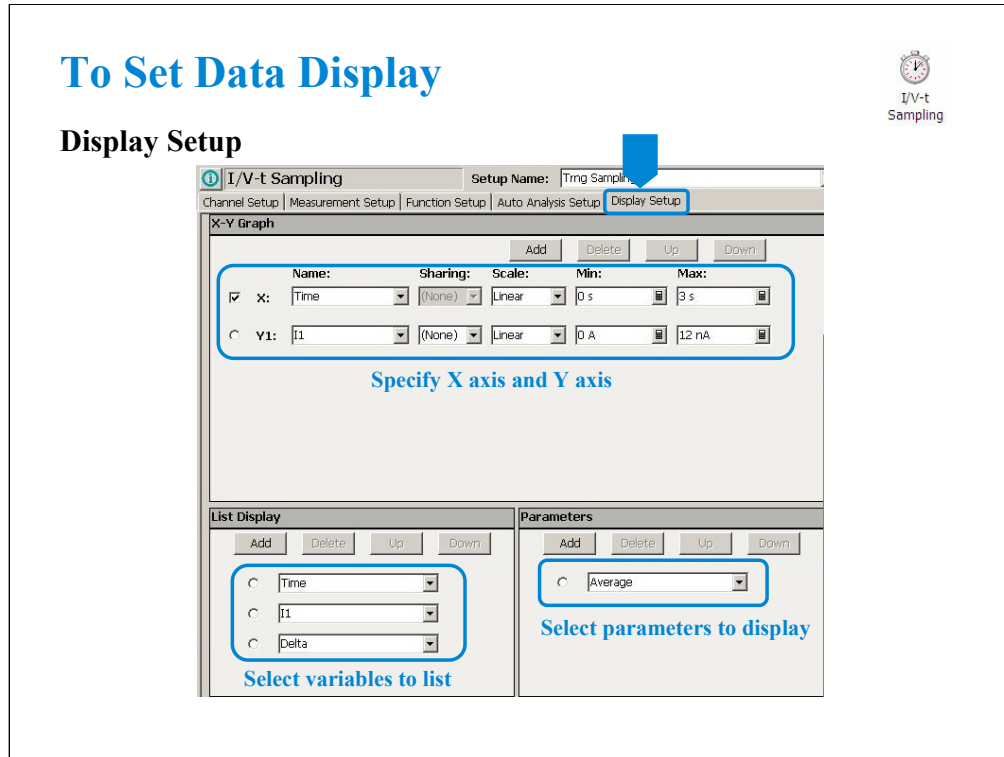

Click the Display Setup tab to display the display setup screen. The X-Y Graph area is used to set the X axis and Y axis of the X-Y Graph Plot area in the Data Display window.

- Name: Name of variable to plot on the X axis
- Scale: Linear or Log
- Min: Minimum value of the specified axis
- Max: Maximum value of the specified axis

The List Display area selects the variables to be listed in the List Display area of the Data Display window. Up to 20 variables can be set.

The Parameters area selects the variables to be listed in the Parameters area of the Data Display window. Up to 20 parameters can be set.

Class Exercise



Define test setup and perform test.

1. Click I/V-t Sampling icon and open setup editor.
2. Define test setup as shown in the previous pages.
3. Save it as Trng Sampling.
4. Connect device (capacitance), and perform test.
5. Export preset group, and import it.



Note:

Measurement Result Example

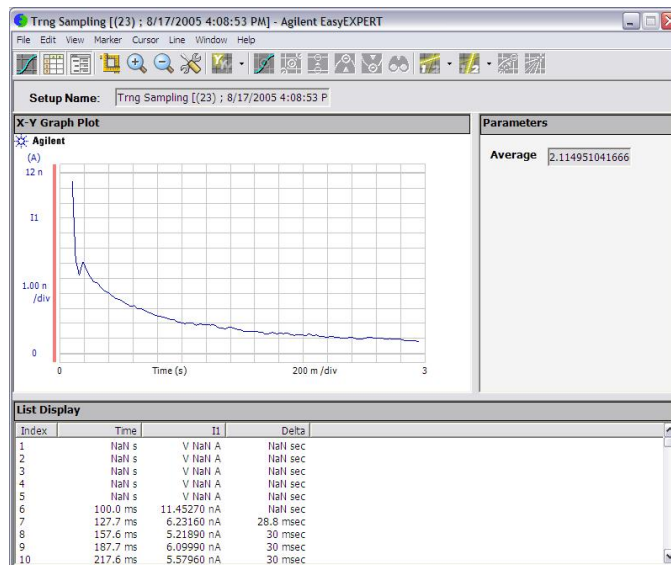

This is a test result example displayed on the Data Display window.

C-V Sweep Measurement



C-V Sweep

- To Define Channels and Variables
- To Set Sweep Source
- To Set Signal Source
- To Set Measurement Timing and Abort Function
- To Set SMU Outputs (CONST)
- Range/Advanced
- To Set User Functions/
Analysis Functions
- To Set Data Display
- To Perform Compensation
and Correction

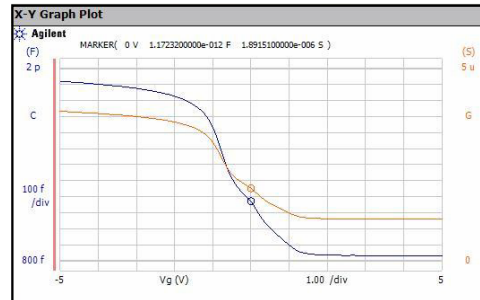

This section explains how to perform C-V sweep measurement. You will perform the above tasks to execute the C-V sweep measurement.

To Define Channels and Variables



C-V Sweep

Channel Setup

Setup Name:

Channel Setup | Measurement Setup | Function Setup | Auto Analysis Setup | Display Setup

Channel Definition

Unit:	V Name:	I Name:	Mode:	Function:
SMU1:HP	Vs	I1	V	CONST
SMU2:HR	Vd	I2	V	CONST
CMU1:MF	Vg			VAR1

Channel Definition
 -CMU/SMU
 -V name/I name
 -I/V/COMMON

Variable name for time stamp data →

Variable name for data index →

Miscellaneous Variables

Time Stamp Name: Index Name:

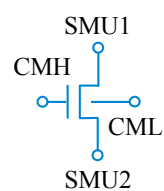

SMU1
CMH
SMU2
CML

Click the C-V Sweep icon and open the setup editor. Then click the Channel Setup tab to display the channel definition screen.

- Enter the Setup Name for the test setup to be defined on the setup editor.
- List units used for source output or measurement, and set the following parameters.
 - Unit: MFCMU/SMU name or number
 - V Name: Variable name for the voltage measurement or source data
 - I Name: Variable name for the current measurement or source data
 - Mode: Source output mode, V (voltage), I (current), or COMMON (ground)
 - Function: CONST or VAR1
 - Time Stamp Name: Variable name for the time stamp data
 - Index Name: Variable name for the data index

You can read measurement data by using the Data Display window. Parameters displayed on the window are selected on the Display Setup tab screen. If you enter the variable name in the V Name, I Name, Time Stamp Name, and/or Index Name entry fields, you can choose the variables as the display parameters.

Note: The time stamp is the time the measurement is started for each measurement point. The index is the index number for each measurement data.

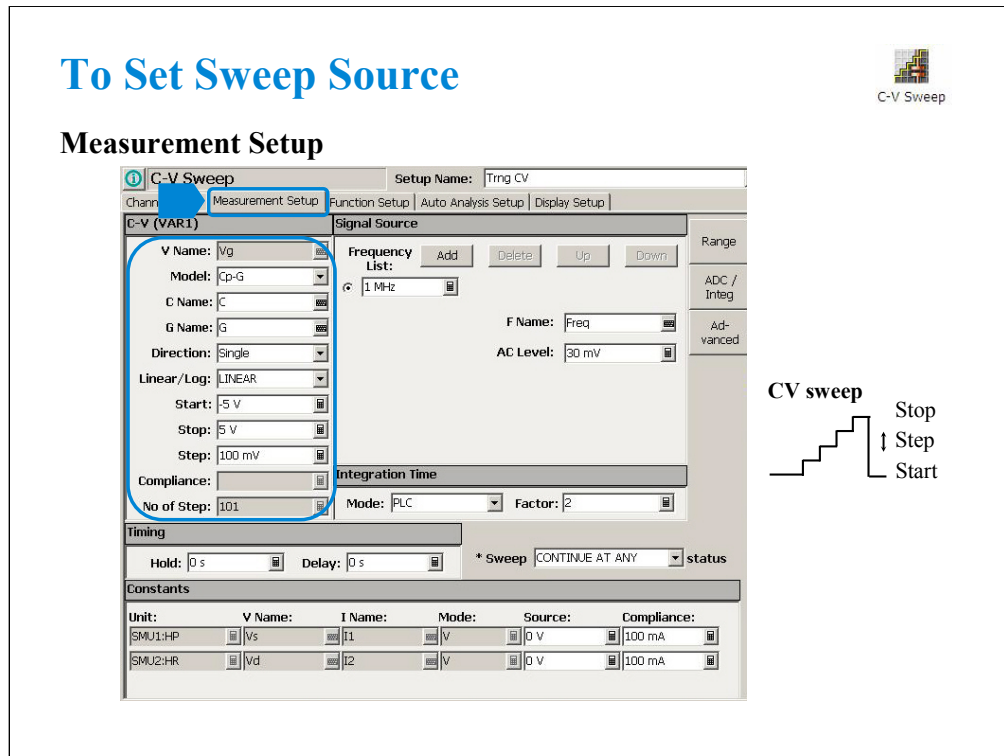

The Measurement Setup tab screen is used to set the source output and timing parameters.

At the C-V(VAR1) area, you set the DC bias output of the MFCMU.

- V Name: Variable name of the MFCMU output
- Model: MFCMU measurement mode. Primary and secondary measurement parameters.
- (C) Name: Variable name of the primary measurement parameter
- (G) Name: Variable name of the secondary measurement parameter
- Direction: Sweep direction, single (start to stop) or double (start to stop to start)
- Linear/Log: Sweep output, LINEAR, LOG10, LOG25, or LOG50. where the number following LOG means the number of sweep points in one decade.
- Start: Source output start value
- Stop: Source output stop value
- Step: Source output incremental step value
- Compliance: Only for SMU. Compliance value. Enter the current limit value for the voltage source, or the voltage limit value for the current source.
- No of Step: Number of sweep steps

To Set Signal Source



Measurement Setup

C-V Sweep Setup Name: Trng CV

Chan: Measurement Setup | Function Setup | Auto Analysis Setup | Display Setup

C-V (VAR1) | **Signal Source**

V Name: Vg | Model: Cp-G | C Name: C | G Name: G | F Name: Freq | AC Level: 30 mV

Direction: Single | Linear/Log: LINEAR | Frequency List: 1 MHz

Start: -5 V | Stop: 5 V | Step: 100 mV | Integration Time: Mode: PLC | Factor: 2

Compliance: | No of Step: 101

Timing: Hold: 0 s | Delay: 0 s | * Sweep: CONTINUE AT ANY status

Constants

Unit:	V Name:	I Name:	Mode:	Source:	Compliance:
SMU1:HP	Vs	I1	V	0 V	100 mA
SMU2:HR	Vd	I2	V	0 V	100 mA

At the Signal Source area, you set the MFCMU output frequency and oscillator level.

- Frequency List: MFCMU output frequency
- F Name: Variable name of MFCMU output frequency
- AC Level: MFCMU oscillator level, 10 mV to 250 mV, 1 mV resolution

To Set Meas. Timing and Abort Function



Measurement Setup

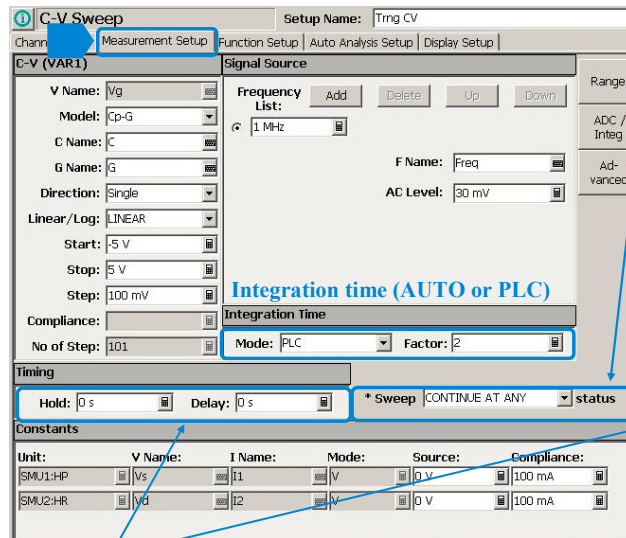

Sweep abort function

CONTINUE AT ANY
STOP AT ANY
ABNORMAL
-Range overflow
-MFCMU error
-SMU compliance
-SMU oscillation

Trigger

Measurement time

Delay time

Hold time

Integration time (AUTO or PLC)

Timing parameters

At the Integration Time area, you set the integration time of the impedance measurement by the MFCMU.

- Mode: AUTO or PLC. Rule to decide the integration time. For details, see online help or User's Guide.
- Factor: Coefficient for the reference value of the integration time.

At the Timing area, you set the source output and measurement timing.

- Hold: Source output hold time. Time after the measurement trigger until starting delay time.
- Delay: Measurement start delay time. Time after the hold time until starting measurement.

The Sweep [] status field sets the sweep abort function.

When this field is CONTINUE AT ANY, the sweep measurement is not aborted.

When this field is STOP AT ANY ABNORMAL, the sweep measurement will be aborted when one of the following conditions is detected.

- Measurement range overflow
- MFCMU error
- SMU compliance
- SMU oscillation

To Set CONST Outputs



Measurement Setup

C-V Sweep Setup Name: Trng CV

Chann Measurement Setup Function Setup Auto Analysis Setup Display Setup

C-V (VAR1) **Signal Source**

V Name: Vg Model: Cp-G C Name: C G Name: G

Frequency List: 1 MHz

F Name: Freq AC Level: 30 mV

Direction: Single Linear/Log: LINEAR Start: -5 V Stop: 5 V Step: 100 mV

Compliance: No of Step: 101 Integration Time Mode: PLC Factor: 2

Timing Hold: 0 s Delay: 0 s * Sweep CONTINUE AT ANY status

Constants

Unit:	V Name:	I Name:	Mode:	Source:	Compliance:
SMU1:HP	Vs	I1	V	0 V	100 mA
SMU2:HR	Vd	I2	V	0 V	100 mA

SMU output setup

At the Constants area, you set the SMU constant output.

- Unit: SMU name or number
- V Name: Variable name for the voltage measurement or source data
- I Name: Variable name for the current measurement or source data
- Mode: Source output mode, V (voltage), I (current), or COMMON (ground)
- Source: SMU output value
- Compliance: SMU compliance value

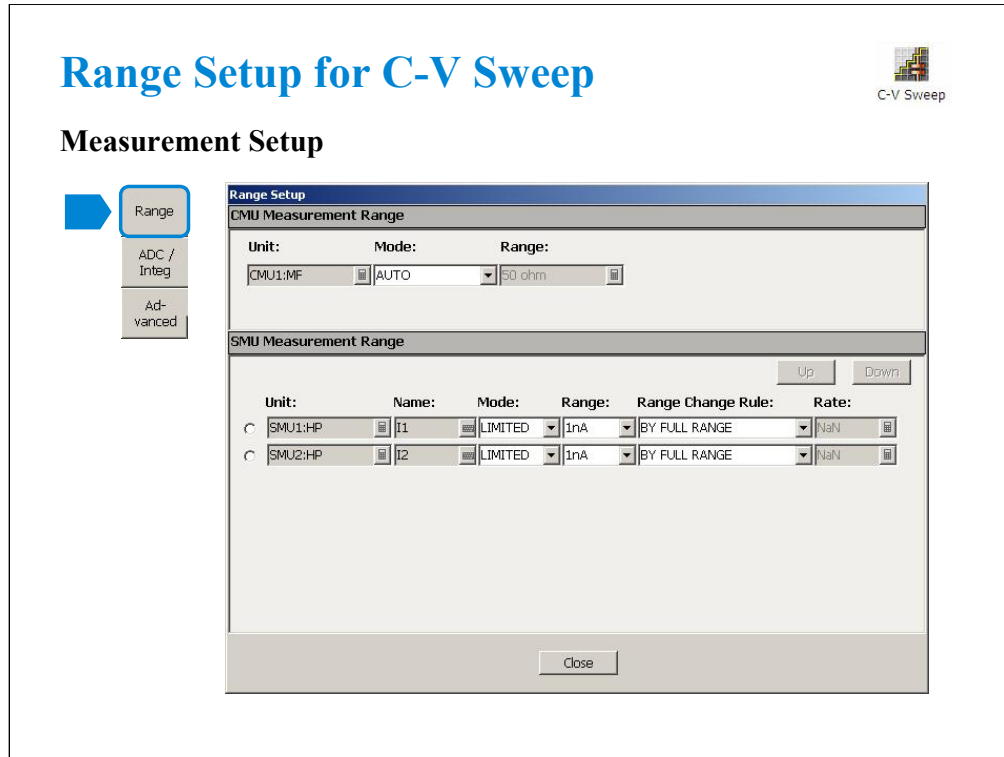

The Range button opens the Range Setup dialog box. The dialog box is used to set the measurement ranging operation.

CMU Measurement Range:

- Unit: CMU name or number
- Mode: Ranging mode, AUTO or FIXED
- Range: Measurement range. This field is effective when Mode=FIXED. Available values are 50 ohm, 100 ohm to 300 kohm ($=<200$ kHz), 100 ohm to 30 kohm ($=<2$ MHz), and 100 ohm to 3 kohm ($=<5$ MHz) in 1, 3 step

SMU Measurement Range:

- Unit: SMU name or number
- Name: Variable name for the measurement data
- Mode: Ranging mode, AUTO, LIMITED, or FIXED
- Range: Range value
- Range Change Rule: BY FULL RANGE, GO UP AHEAD, or UP AND DOWN AHEAD
- Rate: Value used for range changing. See the following formula.

For the AUTO or LIMITED, SMU automatically selects the minimum range that covers the measurement value, and performs the measurement by using the range. For the limited auto ranging, the instrument does not use the range lower than the specified range value. For example, if you select the 100 nA limited auto ranging, the instrument never uses the 10 nA range and below.

BY FULL RANGE performs normal auto ranging operation.

For the GO UP AHEAD and UP AND DOWN AHEAD rules, specify the *Rate* value, 11 to 100, which fixes the boundary of the ranging. The ranging occurs when the measurement data goes across the *boundary* values shown below.

$$\text{go up boundary} = \text{present measurement range} \times \text{Rate} / 100$$

$$\text{go down boundary} = \text{present measurement range} \times \text{Rate} / 1000$$

The *go down boundary* is available only for the UP AND DOWN AHEAD rule.

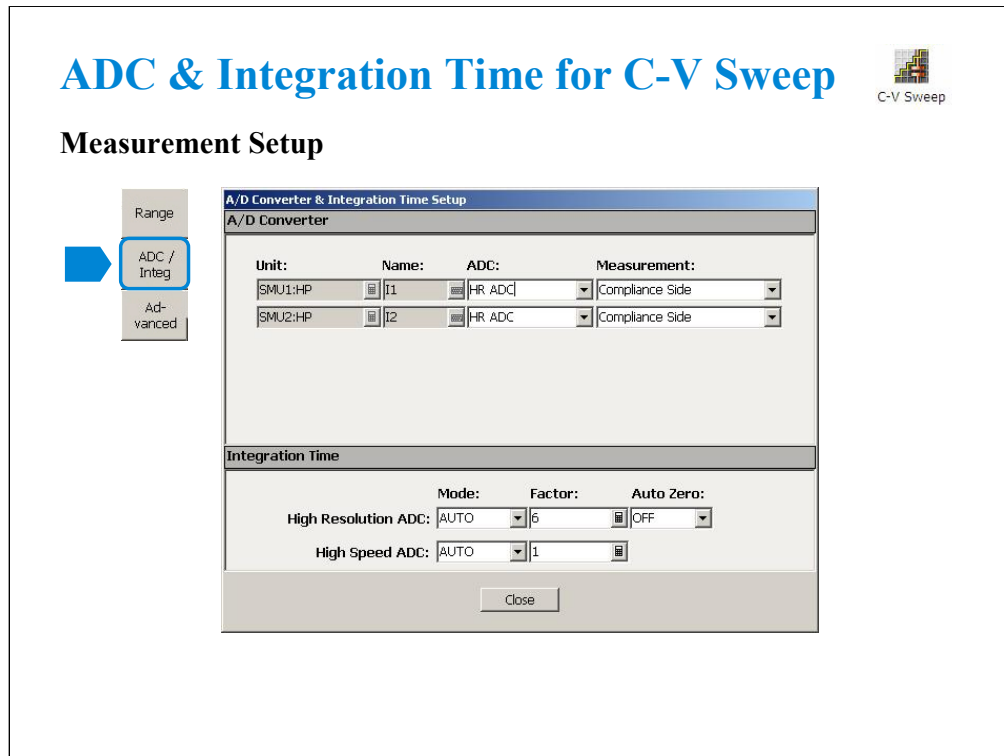

The ADC/Integ button opens the A/D Converter & Integration Time Setup dialog box. The dialog box is used to select the ADC for each SMU and set the integration time for each ADC (high resolution or high speed).

A/D Converter:

- Unit: SMU name or number
 - Name: Variable name of the measurement data
 - ADC: ADC type, HR ADC (high resolution) or HS ADC (high speed)
 - Measurement: Compliance side measurement or Force and Compliance sides measurement.
- HR ADC is not available for HCSMU, HVSMU, and the measurement which uses SMU pulse.
Force and Compliance sides measurement is not available for HRSMU, MPSMU, and HPSMU.

Integration Time:

- Mode: ADC operation mode
AUTO, MANUAL, or PLC for HR ADC
AUTO, MANUAL, PLC, or TIME for HS ADC
- Factor: Coefficient for the reference value of the integration time.
- Auto Zero: Auto Zero function ON or OFF. For HR ADC.

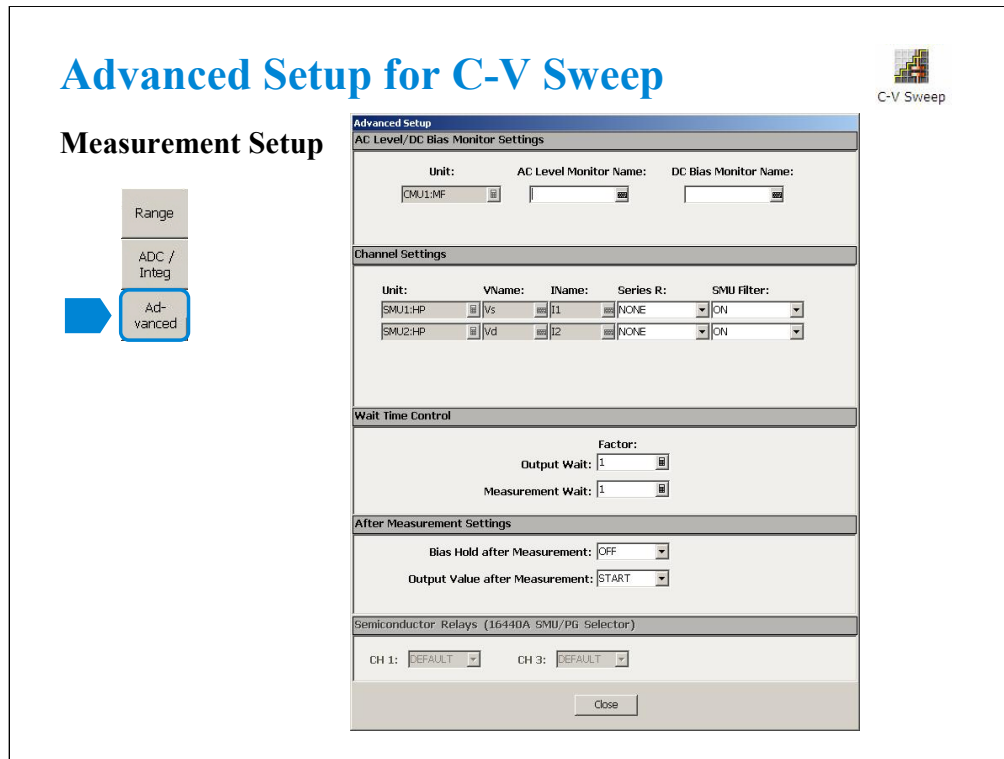

The Advanced button opens the Advanced Setup dialog box used to set the following functions.

AC Level/DC Bias Monitor Settings:

Defines the variables for the AC level data and the DC bias data monitored by the MFCMU while the capacitance measurement is performed.

Channel Settings:

- Unit: SMU name or number
- V Name: Variable name for the voltage measurement or source data
- I Name: Variable name for the current measurement or source data
- Series R: SMU series resistor NONE or 1MOHM (1000000 ohm)
- SMU Filter: SMU filter ON or OFF

Wait Time Control:

- Factor: Coefficient for the reference value of the wait time. For details, see online help or User's Guide.

After Measurement Settings:

- Bias Hold after Measurement: Bias hold function ON or OFF.
- Output Value after Measurement: Source output value after measurement. START (sweep start value) or STOP (sweep stop value)

Semiconductor Relays (16440A SMU/PG Selector):

- CH1: Default or PGU OPEN
- CH3: Default or PGU OPEN

The fields define the selector channel's switch condition during the measurement. Default is the setting defined on the SMU/PG Selector screen of the Configuration window.

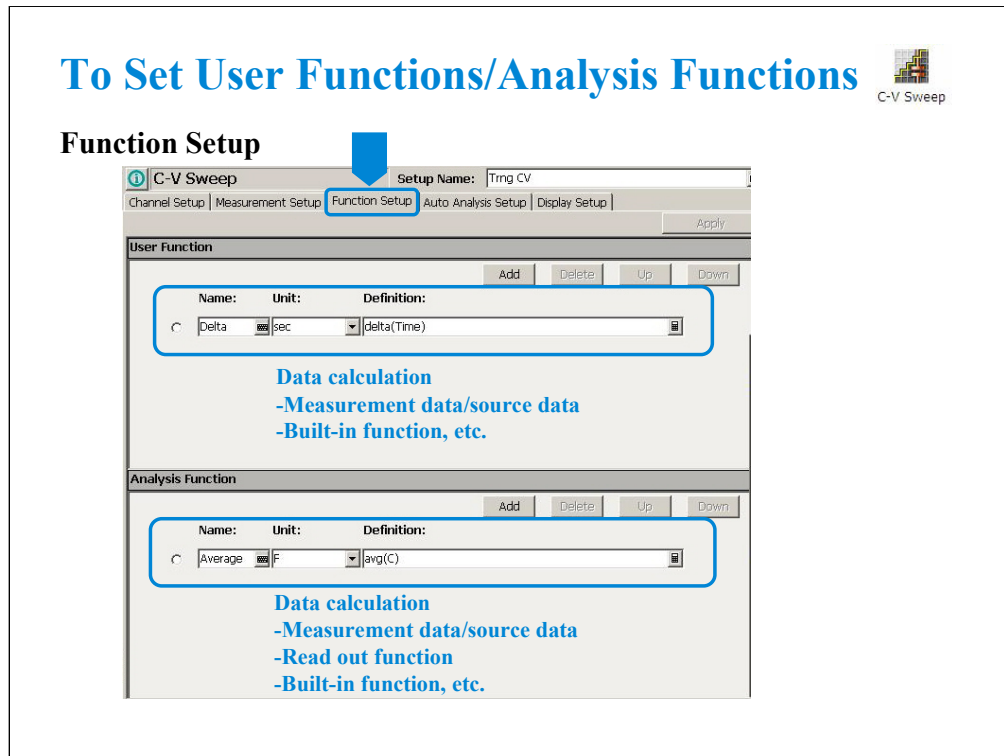

Click the Function Setup tab to display the User Function/Analysis Function setup screen.

The user functions can be displayed on the X-Y Graph Plot, List Display, and Parameters area of the Data Display window. Up to 20 functions can be set.

- Name: Function name
- Unit: Unit of the function
- Definition: Definition of the function. The following identifiers can be used.
 - Variables for the measurement/output data used in this test
 - Functions defined in the above lines
 - Local variables passed from the application test that calls this test as a component
 - Built-in functions and global variables

For details, see online help or User's Guide.

The analysis functions can be displayed on the Parameters area of the Data Display window. Up to 20 functions can be set.

- Name: Function name
- Unit: Unit of the function
- Definition: Definition of the function. The following identifiers can be used.
 - Variables for the measurement/output data used in this test
 - Functions defined in the above lines
 - Local variables passed from the application test that calls this test as a component
 - Built-in functions and global variables
 - Read out functions

For details, see online help or User's Guide.

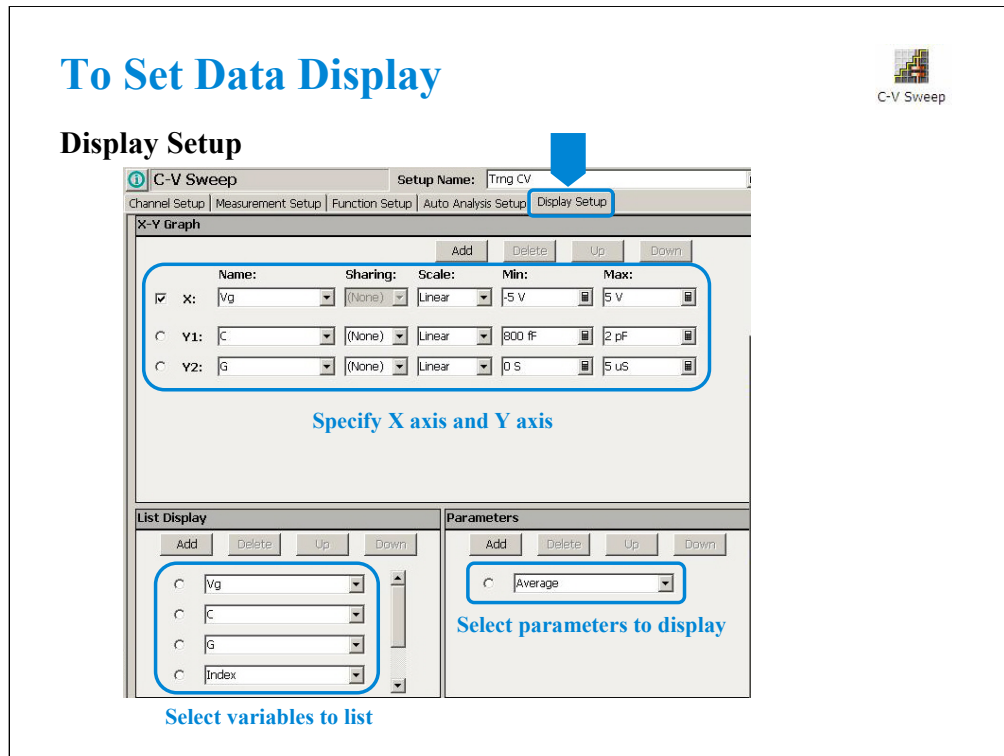

Click the Display Setup tab to display the display setup screen. The X-Y Graph area is used to set the X axis and Y axis of the X-Y Graph Plot area in the Data Display window.

- Name: Name of variable to plot on the X axis
- Scale: Linear or Log
- Min: Minimum value of the specified axis
- Max: Maximum value of the specified axis

The List Display area selects the variables to be listed in the List Display area of the Data Display window. Up to 20 variables can be set.

The Parameters area selects the variables to be listed in the Parameters area of the Data Display window. Up to 20 parameters can be set.

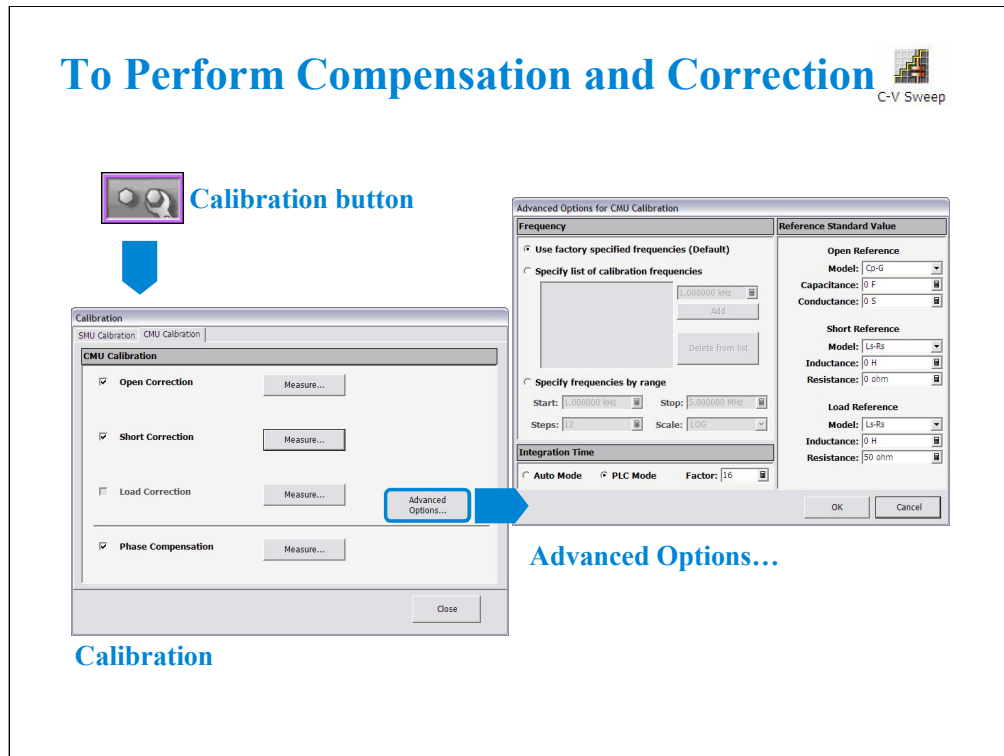

The MFCMU is equipped with the error correction function used to realize accurate impedance measurements. The correction function minimizes the effects of the error elements in the extension cables and the DUT interface such as manipulator and probe card.

- Phase compensation: Corrects phase error caused by extending measurement cables.
- Open correction: Corrects for stray admittance. Effective for high impedance measurements.
- Short correction: Corrects for residual impedance. Effective for low impedance measurements.
- Load correction: Corrects any error by using the working standard (load standard).

Click the Calibration button to open the Calibration window. And click the CMU calibration tab on the window to perform the compensation and correction data measurement.

- To measure the phase compensation data, open the measurement terminals at the end of the device side and click the Measure... button.
- To measure the open correction data, open the measurement terminals at the end of the device side and click the Measure... button.
- To measure the short correction data, connect the measurement terminals together at the end of the device side and click the Measure... button.
- To measure the load correction data, connect the load standard that has the reference value or calibration value. Then, click the Measure... button.

For details of the error correction (CMU calibration) and the Advanced Options, see online help or User's Guide. The Advanced Options window is used for the compensation/correction data measurement setup.

Class Exercise



Define test setup and perform test.

1. Click C-V Sweep icon and open setup editor.
2. Define test setup as shown in previous pages. And save it as Trng CV.
3. Open measurement terminals, and perform phase compensation and open correction.
4. Connect device, and perform test.
5. Export preset group, and import it.

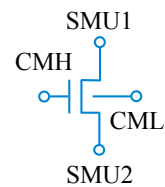

Note:

Measurement Result Example

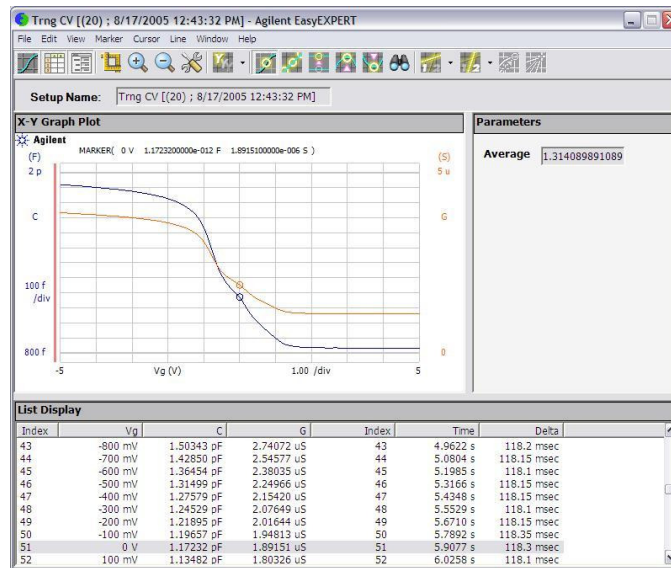

This is a test result example displayed on the Data Display window.

Switching Matrix Control

- To Define Switch Setup



This section explains how to define the switch setup for B2200/E5250 Switching Matrix. Not available for B1505A.

Note: Standard revision of EasyEXPERT cannot support the E5250. The E5250 control is optional function of B1540A-002/B1541A-002.

Note: EasyEXPERT supports the E5250A installed with the E5252A matrix card.

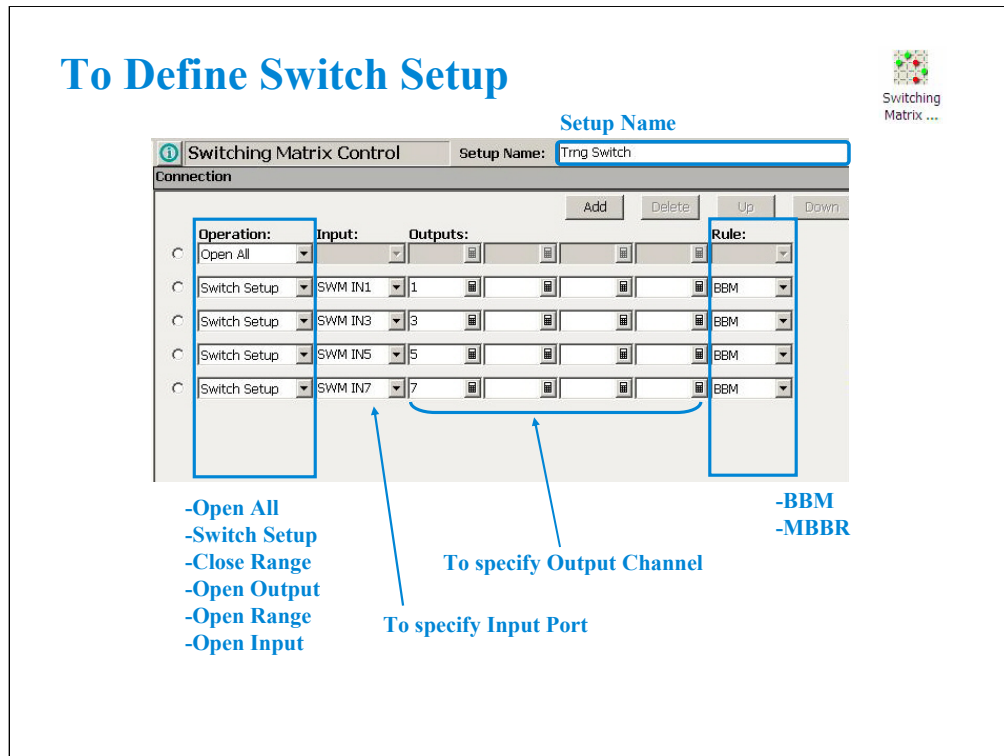

This setup screen is used to create the relay control setup (switch setup) for Agilent B2200A/B2201A/E5250A Switching Matrix.

To send the switch setup to B2200/E5250, click the Single button. Before doing this, you have to establish the GPIB connection to B2200/E5250 by using the Switching Matrix tab screen of the Configuration window and B1500A is set to system controller. See Module 8.

This screen provides the following GUI.

Add: Adds a setup row for relay connection.

Delete: Deletes the setup row. To select the setup row, use the left radio button.

Up: Moves the selected setup row upward.

Down: Moves the selected setup row downward. The setup row provides the following entry fields.

Operation: Relay control operation. Open All, Switch Setup, Close Range, Open Output, Open Range, or Open Input. See the next page.

Input: B2200/E5250 input port number or label. Available for the Switch Setup, Close Range, and Open Input operations.

Outputs: B2200/E5250 output channel number or label. Four entry fields are available for the Switch Setup and Open Output operations to specify the output channels. Two entry fields are available for the Close Range and Open Range operations to specify the range of output channels.

Rule: Relay connection rule. BBM or MBBR.

- BBM: Breaks the previous connection and then makes the new connection for the specified outputs.
- MBBR: Makes the new connection and then breaks the previous connection for the specified outputs.

Operation and number of Outputs



Operation	Description	Number of Outputs
Open All	Opens all relays.	0
Switch Setup	Makes the connection from the specified input port to the specified output channels. Up to four output channels can be specified at once.	4
Close Range	Makes the connection from the specified input port to the specified output channels. They are between two channels given by the Outputs fields.	2
Open Output	Opens the relays connected to the specified output channels. Up to four output channels can be specified at once.	4
Open Range	Opens the relays connected to the specified output channels. They are between two channels given by the Outputs fields.	2
Open Input	Opens the relays connected to the specified input port.	0

Note:

Class Exercise



Define switch setup and send it to B2200/E5250.

1. **Click Switching Matrix Control icon and open setup editor.**
2. **Define switch setup as you want. And save it as Trng Switch.**
3. **If B2200/E5250 is available, establish the GPIB connection between B1500A (must be set to system controller) and B2200/E5250, and apply your switch setup.**

Note:

Direct Control

- **To Define Channels and Variables**
- **To Set Measurement Conditions**
- **Advanced Setup**
- **To Set User Functions**
- **To Set Data Display**



Direct
Control

This section explains how to use Direct Control to perform various measurements (e.g. C-f measurement, Quasi-Static C-V measurement) using Agilent FLEX commands.

To Define Channels and Variables



Direct Control

Channel Setup

Setup Name:

Channel Setup | Measurement Setup | Function Setup | Auto Analysis Setup | Display Setup

Channel Definition

Add SMU | Add CMU | Add SPGU | Delete | Up | Down

Unit:	V Name:	I Name:
CMU1:MF	VBias	
SMU1:HP	V1	I1

CMU Channel Definition: V Name
SMU Channel Definition: V Name and I Name
SPGU Channel Definition: No variable

Additional Data Variables

Additional Data Variables | Add | Delete

Unit:	Type:	Name:
CMU1:MF	CMU Re(Y)	G
CMU1:MF	CMU Im(Y)	B
CMU1:MF	CMU DC Bias Monitor Data	DcMon

Miscellaneous Variables

Time Stamp Name: | Index Name:

Variable name for time stamp data Variable name for index data

Click the Direct Control icon and open the setup editor. Then click the Channel Setup tab to display the channel definition screen.

1. Enter the Setup Name for the test setup to be defined on the setup editor.
2. List channels used for source output or measurement, and set the following parameters.

- Unit: Name or number of the channel
- V Name: Variable name for the voltage measurement or source data. For SMU and CMU.
- I Name: Variable name for the current measurement or source data. For SMU only.

V Name and I Name are used to specify the parameters displayed on the Data Display window. The display parameters are selected on the Display Setup tab screen.

You can read measurement data by using the Data Display window. Parameters displayed on the window are selected on the Display Setup tab screen. If you enter the variable name in the V Name, I Name, Additional Variable Name, Time Stamp Name, and/or Index Name entry fields, you can choose the variables as the display parameters.

Note: The time stamp is the time the measurement is started for each measurement point. The index is the index number for each measurement data.

For example, the Trng C-f test setup has defined the following additional variables to monitor.

<Unit>	<Type>	<Name>
CMU1:MF	CMU Re(Y)	G
CMU1:MF	CMU Im(Y)	B
CMU1:MF	CMU DC Bias Monitor Data	DcMon
CMU1:MF	CMU AC Level Monitor Data	AcMon
CMU1:MF	CMU Frequency	Freq

To Set Measurement Conditions



Measurement Setup

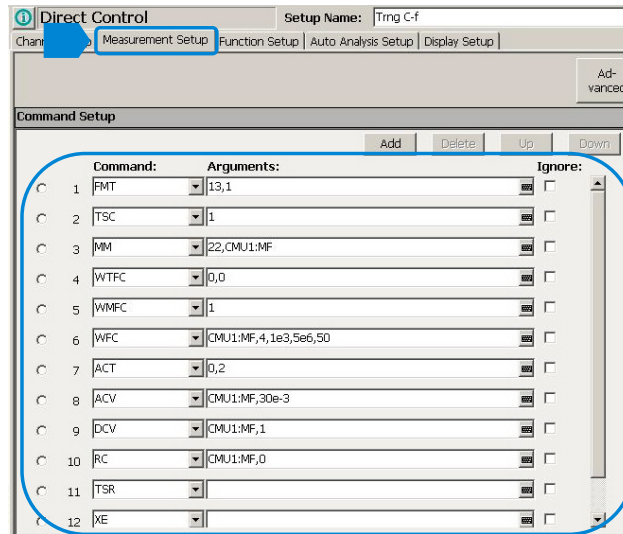

Command Setup

The Measurement Setup tab screen is used to set Agilent FLEX commands for measurement. For example, following FLEX commands are set for the C-f Sweep Measurement.

<Command>	<Arguments>
1 FMT	13,1
2 TSC	1
3 MM	22,CMU1:MF
4 WTFC	0,0
5 WMFC	1
6 WFC	CMU1:MF,4,1e3,5e6,50
7 ACT	0,2
8 ACV	CMU1:MF,30e-3
9 DCV	CMU1:MF,1
10 RC	CMU1:MF,0
11 TSR	
12 XE	
13 ReadDataBuffer	

See B1500 Series Programming Guide for more details about FLEX commands.

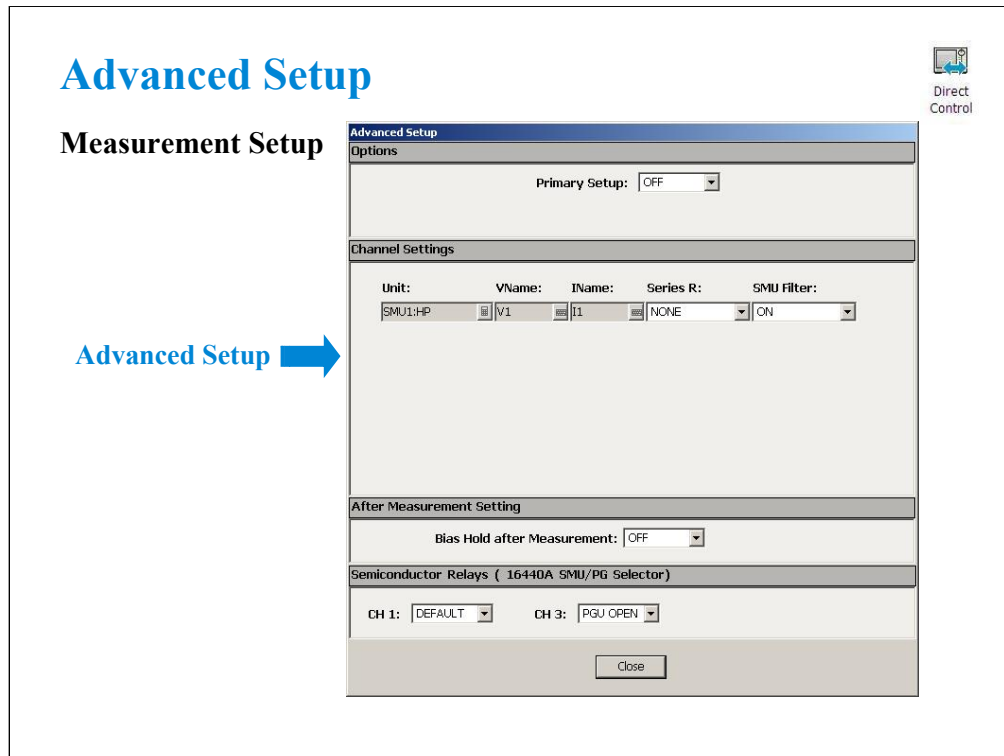

The Advanced button opens the Advanced Setup dialog box. The dialog box is used to set the option setting, the SMU filter and SMU series resistor settings, the after measurement settings, and the 16440A selector semiconductor relay setting.

Options:

- Primary Setup: ON or OFF.

If Primary Setup=ON, the primary setup is applied to the instrument when the Direct Control test is started. For the primary setup condition, see the online help or User's Guide.

Channel Settings:

- Unit: SMU name or number
- V Name: Variable name for the voltage measurement or source data
- I Name: Variable name for the current measurement or source data
- Series R: SMU series resistor NONE or 1MOHM (1000000 ohm)
- SMU Filter: SMU filter ON or OFF

After Measurement Settings:

- Bias Hold after Measurement: Bias hold function ON or OFF.

Semiconductor Relays (16440A SMU/PG Selector):

- CH1: Default or PGU OPEN
- CH3: Default or PGU OPEN

The fields define the selector channel's switch condition during the measurement. Default is the setting defined on the SMU/PG Selector screen of the Configuration window.

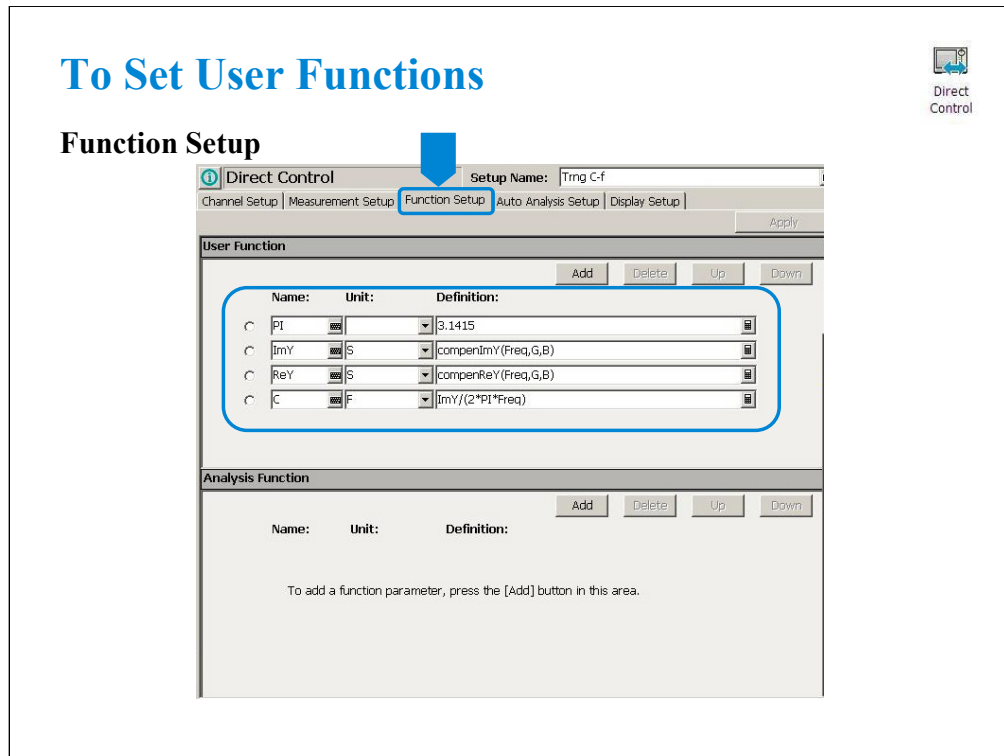

Click the Function Setup tab to display the User Function/Analysis Function setup screen. The user functions can be displayed on the X-Y Graph Plot, List Display, and Parameters area of the Data Display window. Up to 20 functions can be set.

Name: Function name

Unit: Unit of the function

Definition: Definition of the function. The following identifiers can be used.

-Variables for the measurement/output data used in this test

-Functions defined in the above lines

-Local variables passed from the application test that calls this test as a component

-Built-in functions and global variables

For details, see online help or User's Guide.

For example, following user functions are set for C-f Sweep Measurement.

<Name> <Unit> <Definition>

PI		3.1415
ImY	S	compenImY(Freq,G,B)
ReY	S	compenReY(Freq,G,B)
C	F	ImY/(2*PI*Freq)

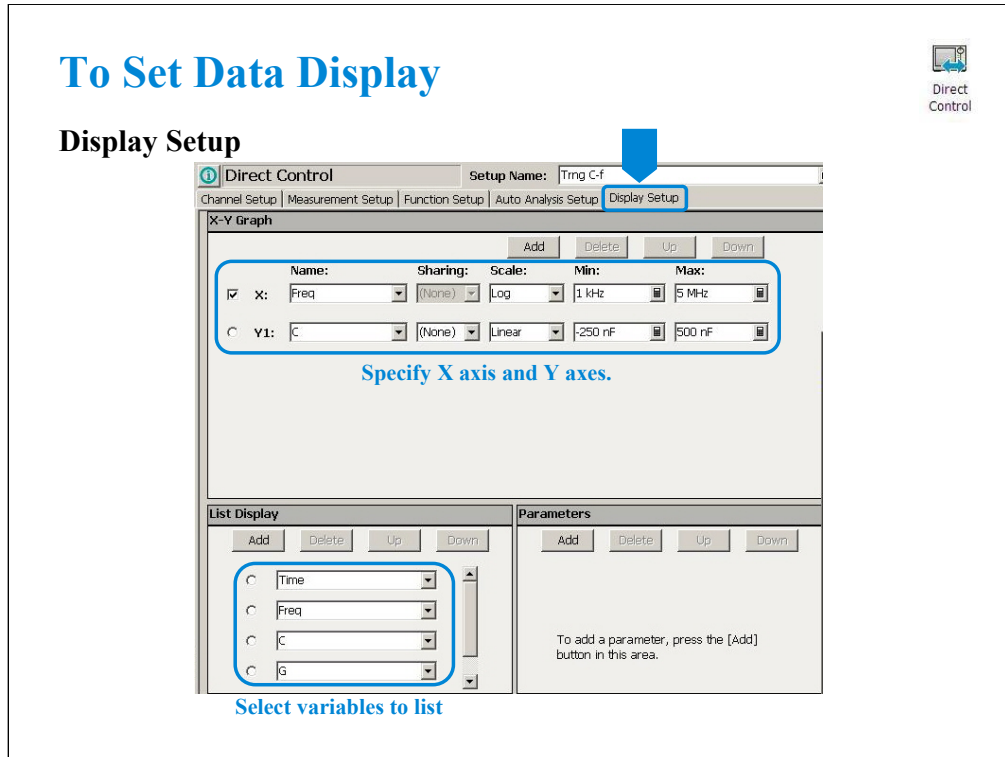

Click the Display Setup tab to display the display setup screen. The X-Y Graph area is used to set the X axis and Y axes of the X-Y Graph Plot area in the Data Display window.

- Name: Name of variable to plot on the axis
- Scale: Linear or Log
- Min: Minimum value of the specified axis
- Max: Maximum value of the specified axis

For example, following axes are set for the C-f Sweep Measurement.

	<Name>	<Scale>	<Min>	<Max>
X	Freq	Linear	1 kHz	5 MHz
Y1	C	Linear	-250 nF	500 nF

The List Display area selects the variables to be listed in the List Display area of the Data Display window. Up to 20 variables can be set.

For example, following variables are set for the C-f Sweep Measurement.

Time, Freq, C, G, B

Class Exercise



Define test setup and perform test.

1. **Click Direct Control icon and open setup editor.**
2. **Define test setup as shown in the previous pages.**
3. **Save it as Trng C-f.**
4. **Connect a device (capacitance) as shown in next several pages, and perform test.**
5. **Export preset group, and import it.**

Note:

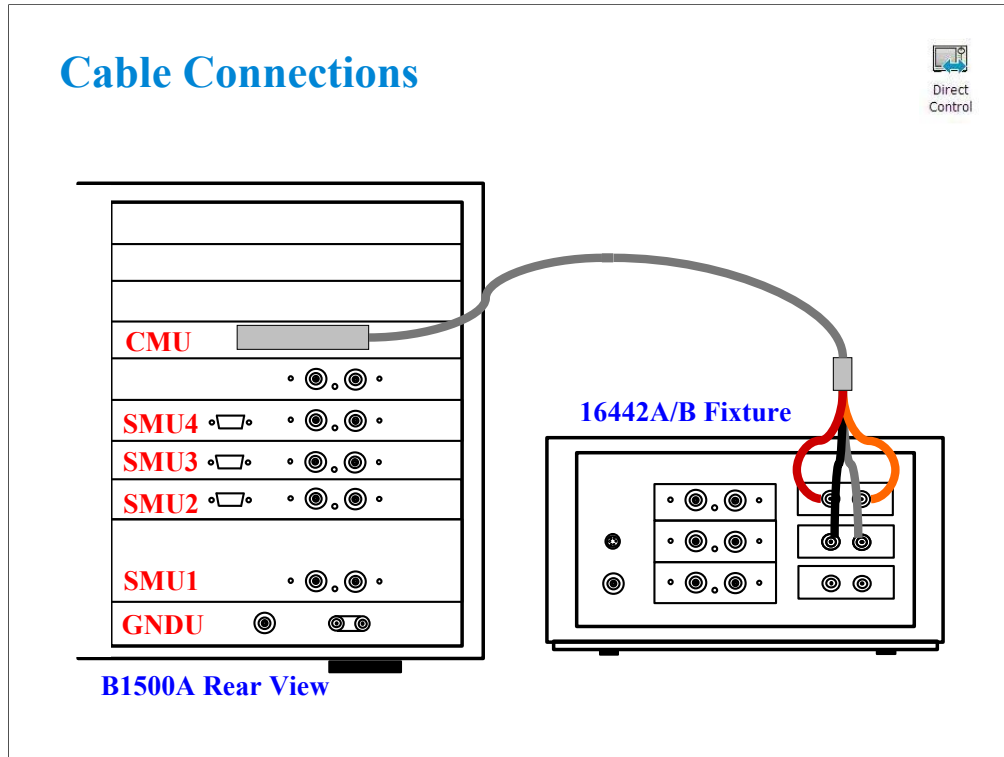

The following cables are required to perform this class exercise.

CMU cable (Agilent N1300A-001/002), 1 ea.

One side of the CMU cable forms the attachment used to join and fix it to the CMU. And the other side provides four BNC connectors used to connect the fixture as shown.

Connect the cables between the B1500 and the test fixture as follows.

Hcur : PGU1 (red)

Hpot : PGU2 (orange)

Lcur : VSU1 (black)

Lpot : VSU2 (gray)

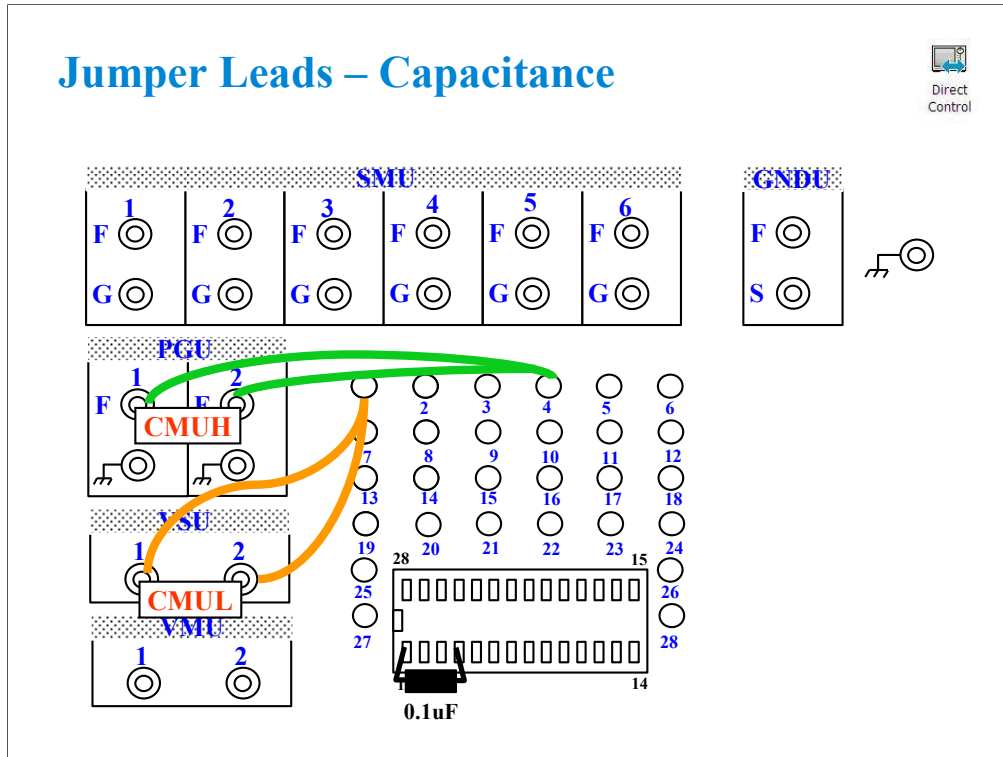

This class exercise requires four jumper leads to connect the DUT. Connect the jumper leads between the following terminals.

- PGU1 : terminal 4
- PGU2 : terminal 4
- VSU1 : terminal 1
- VSU2 : terminal 1

Measurement Result Example

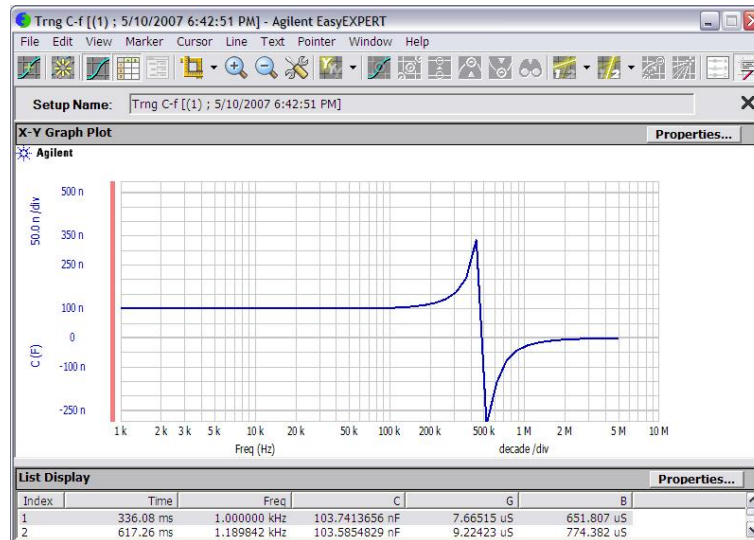

This is a test result example displayed on the Data Display window.



4

Measurement Functions



In This Module

- **SMU Pulsed Sweep Measurement**
- **I/V-t Sampling Measurement**
- **Negative Hold Time for High Speed Sampling**
- **Auto Analysis**
- **SMU Filter**
- **Standby Function**
- **Bias Hold Function**

There are too many measurement functions to conveniently cover in one module. Ultra low current measurement and capacitance measurement are covered in separate modules.

This module covers the key features listed above.

SMU Pulsed Sweep Measurement

- **Use PULSE mode for precise force/measure timing**
- **Use PULSE mode for repeatable high current measurements**
 - **To eliminate heating during IV sweeps**
 - **To avoid device damage**
- **Set the expected maximum measurement value to Compliance**
- **Multiple pulsed source/measurement channels are available for Tracer Test and Multi Channel I/V Sweep Classic Test**

SMUs can be pulsed for precise force/measure timing, or to reduce heating of the device when forcing high currents.

The measurement unit performs measurement by using the compliance range. It is the minimum range which covers the Compliance value. The Compliance value should be the expected maximum measurement value or greater.

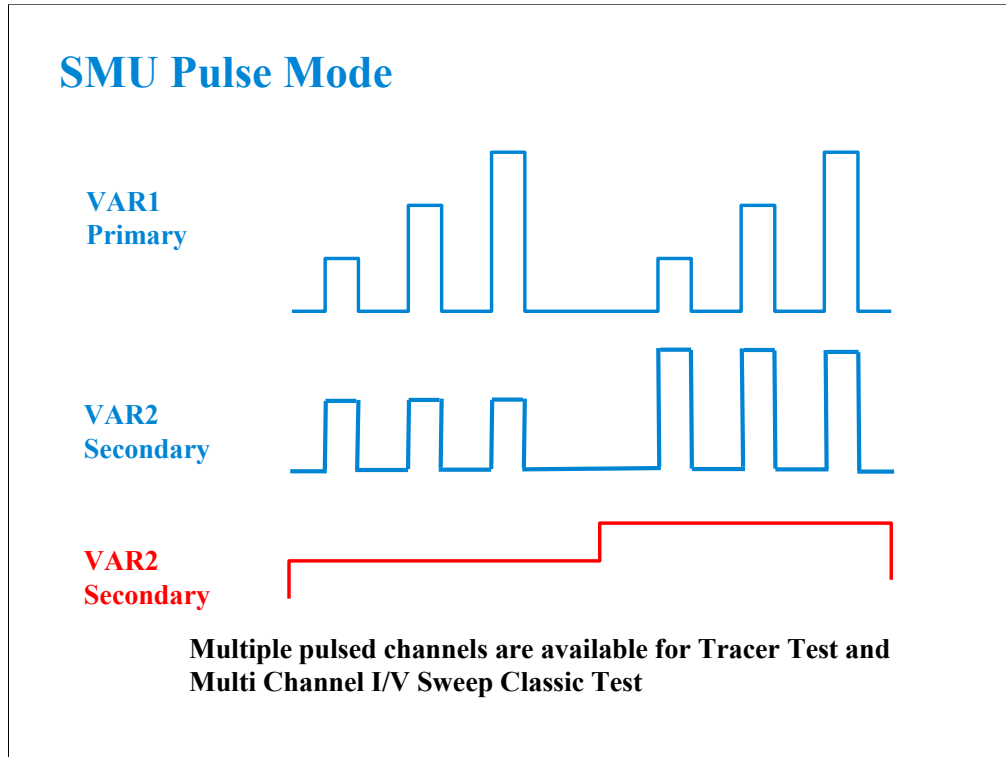

Tracer Test and Multi Channel I/V Sweep Classic Test support multiple pulsed channels. VAR1, VAR2, and CONST can be pulsed.

For the other Classic Test such as I/V Sweep and I/V List Sweep, only one SMU can pulse while another follows. VAR1, VAR1', VAR2, or CONST may be pulsed.

Pulse Setup Parameters

1. Using one pulse output channel

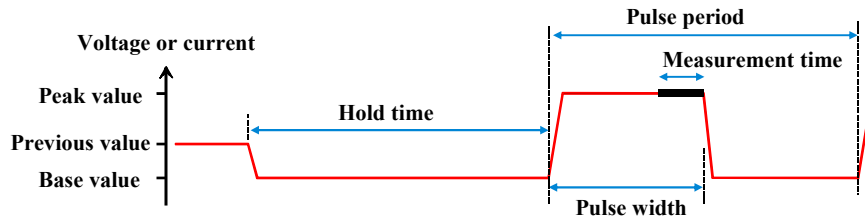

2. Using multiple pulse output channels

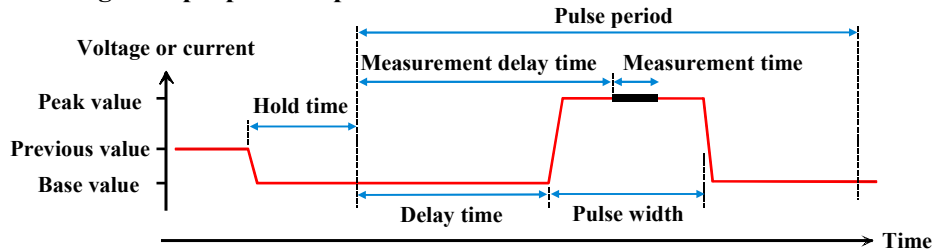

When you select VPULSE or IPULSE on the Channel Setup screen, the Pulse button is available for the Measurement Setup screen. Click the Pulse button to open the Pulse Setup dialog box, and set the pulse setup parameters on the dialog box.

For the test which supports one SMU pulse, use the SMU Pulse area on the Measurement Setup screen to set the pulse setup parameters.

Pulse period may be adjusted from 5 ms to 5 s in 100 us steps. Pulse period is measured from the base value to peak value transition, between two consecutive pulses.

Pulse width may be adjusted from 0.05 ms to 2 s in 2 us steps for HCSMU or 0.5 ms to 2 s in 2 us steps for the other modules. Pulse width is measured between the transition from base value to peak value and the transition from peak value to base value.

Hints on Pulsing the HPSMU – B1500A

- Use the HPSMU or GNDU as the current return path
- Use Kelvin connections (must use on GNDU)
- Use 16493L GNDU cable for the GNDU connection

Example for B1500A:

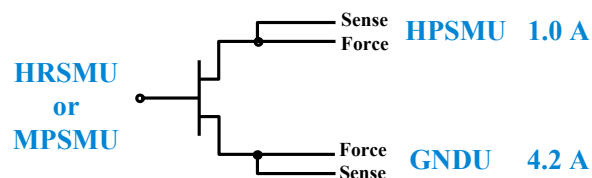

The 1 A SMU (HPSMU) cannot use another MPSMU or HRSMU as the current return. It must be used with the other HPSMU or the GNDU that can sink enough current. The GNDU is the unit that you can use without defining in the Channel Setup.

The GNDU can sink up to 4.2 A, and it is designed for the Kelvin connection. The force and sense lines must be shorted near the DUT.

For the connection of the GNDU, do not use the normal triaxial cable. The GNDU is rated for up to 4.2 A, while the maximum current rating of the triaxial cable is 1 A.

Class Exercise

SMU Pulse Mode

- You will observe a MOS FET family of curves
- You will edit VAR1 from V mode to VPULSE mode
- You will learn how to properly define a "pulsed" algorithm

To Get Started:

- Use the next several pages as you guide
- Get the IDVD setup
- Follow the instructions on the following pages

You will setup a basic MOS family of curves without VPULSE. Then change VAR1 to VPULSE.

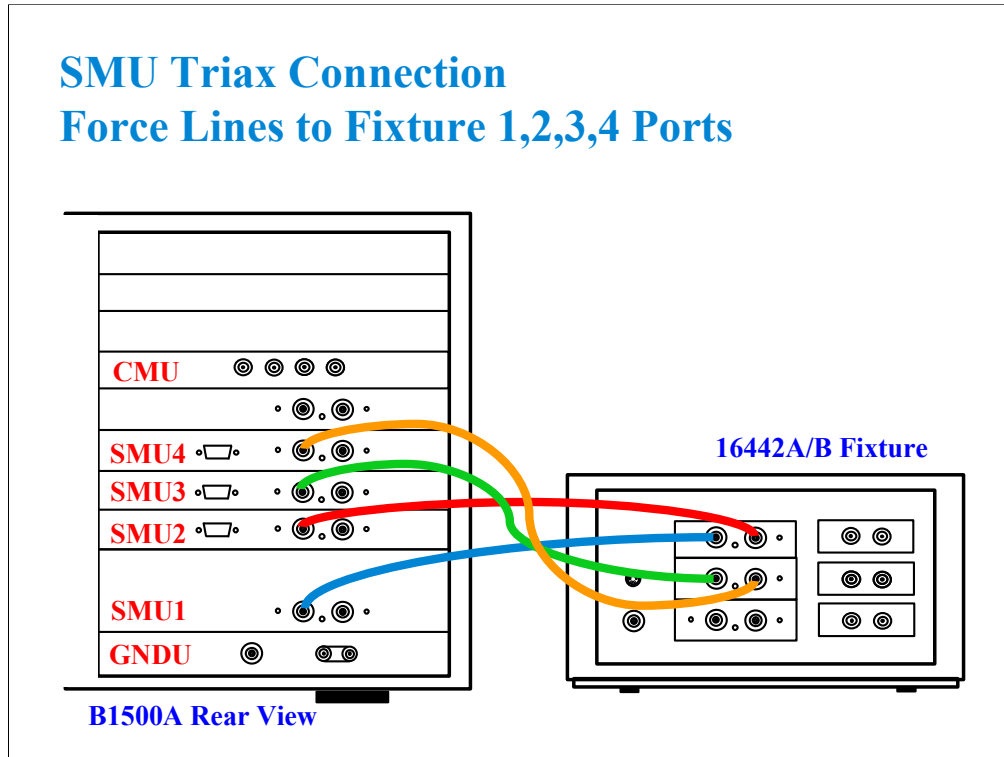

This is the SMU cable setup that will be used in the remainder of the class exercises.

Connect the cables between the B1500 and test fixture as follows.

- SMU1 : SMU1
- SMU2 : SMU2
- SMU3 : SMU3
- SMU4 : SMU4

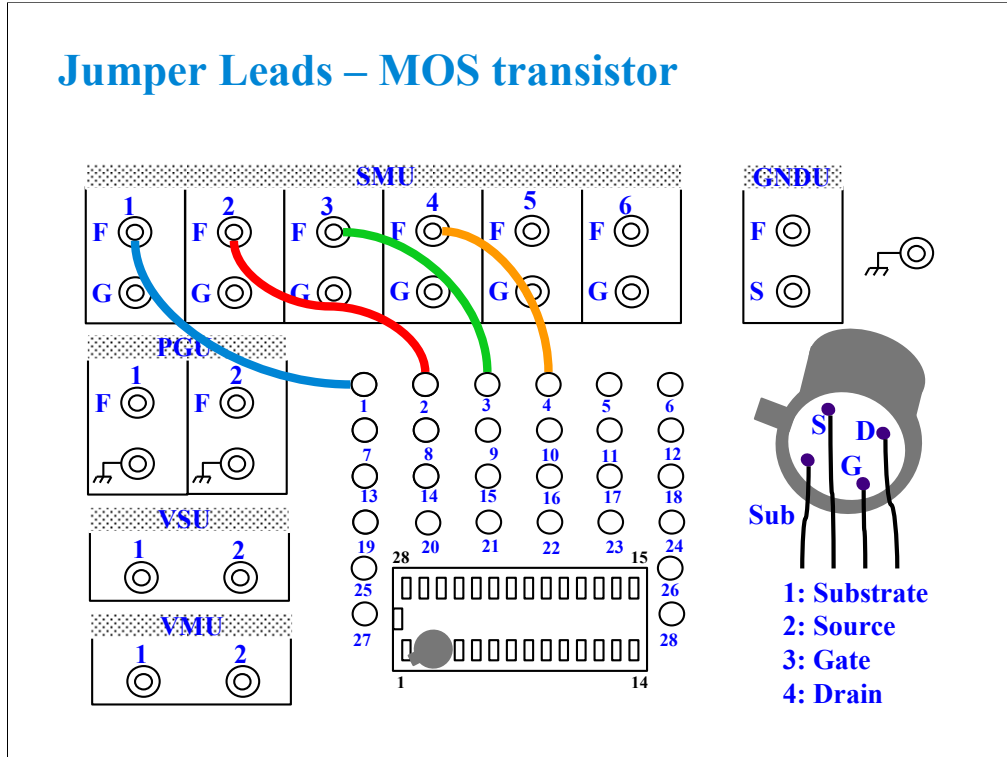

With the 16442A/B fixture, note that there are two SMU numbering schemes...3 SMUs with force and sense, or six SMUs with force only. For this class example we will use the six (6) SMU scheme. On older fixtures, this scheme is shown in light blue lettering. In newer fixtures, this scheme is shown in white reverse background lettering.

VPULSE Data Display Window

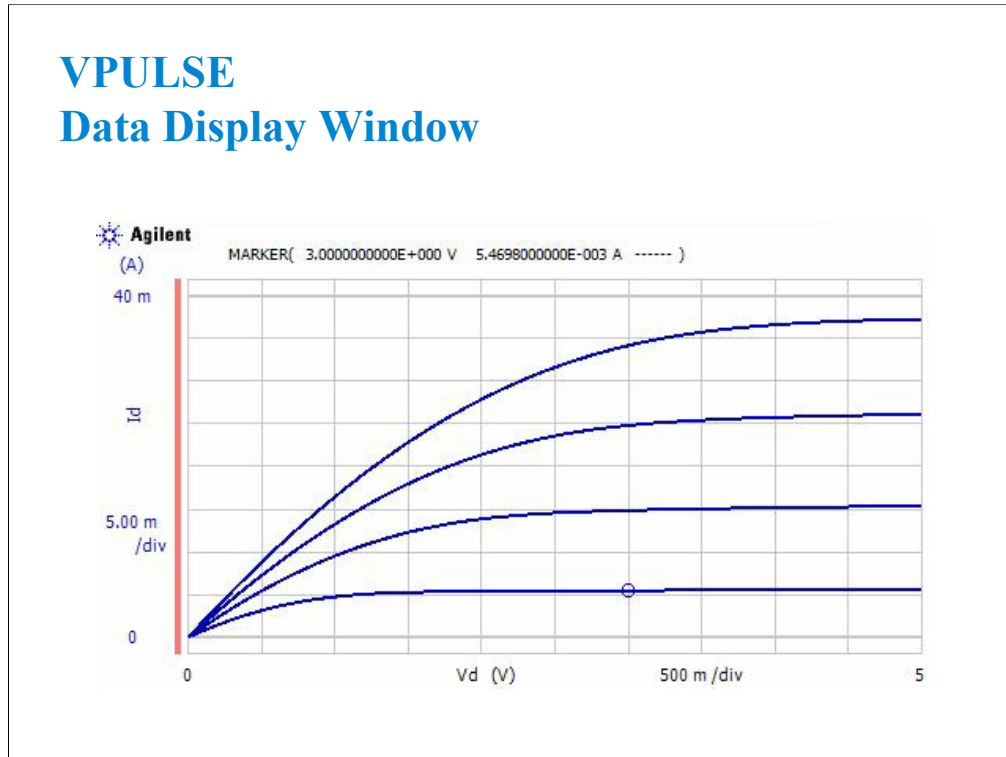

Make a measurement to verify the setup is correct. You should see the above family of curves. The algorithm is defaulted to standard staircase sweep on VAR1 (no pulsed SMU).

VPULSE Channel Setup

Enter new name before save

Channel Setup | Measurement Setup | Function Setup | Auto Analysis Setup | Display Setup

Channel Definition

	Unit:	V Name:	I Name:	Mode:	Function:
<input type="checkbox"/>	SMU1:HP	Vsub	Isub	V	CONST
<input type="checkbox"/>	SMU2:HP	Vs	Is	COMMON	CONST
<input type="checkbox"/>	SMU3:HR	Vg	Ig	V	VAR2
<input type="checkbox"/>	SMU4:HR	Vd	Id	VPULSE	VAR1

Drain pulse

Switch VAR1 from V mode to VPULSE mode. A new panel will pop up on the Measurement Setup.

Before saving this new setup, enter new name into the Setup Name field, then click the Save button.

VPULSE Measurement Setup

The screenshot shows the 'VPULSE Measurement Setup' interface. It is divided into several sections:

- VAR1 and VAR2:** Parameters for two channels, including Unit, Name, Direction, Linear/Log, Start, Stop, Step, No of Step, Compliance, and Pwr Comp.
- Timing:** Hold and Delay settings.
- Constants:** A table with columns for Unit, V Name, I Name, Mode, Source, and Compliance.
- SMU Pulse:** Parameters for the pulse, including Unit, Period, Width, and Base.
- Buttons:** Range, ADC/Integ, and Advanced.

Annotations in blue text and arrows point to specific features:

- Range and ADC/Integ are disabled:** Points to the 'Range' and 'ADC/Integ' buttons.
- This box pops up only if VPULSE or IPULSE is set on Channel Setup:** Points to the 'SMU Pulse' section.
- Maximum measurement value:** Points to the 'Compliance' field in the VAR1 section, which is circled in blue.

Default pulse conditions for the Measurement Setup are shown here. The base is 0, and the pulse duty cycle is 10 %. These settings are OK for this class exercise. Click the Single button to start a pulsed sweep measurement.

Range and ADC/Integ buttons are disabled for pulsed measurement. The measurement range is always the compliance range. And the integration time cannot be changed.

For example, if you change the Compliance value to 30 mA, the data beyond 30 mA cannot be measured.

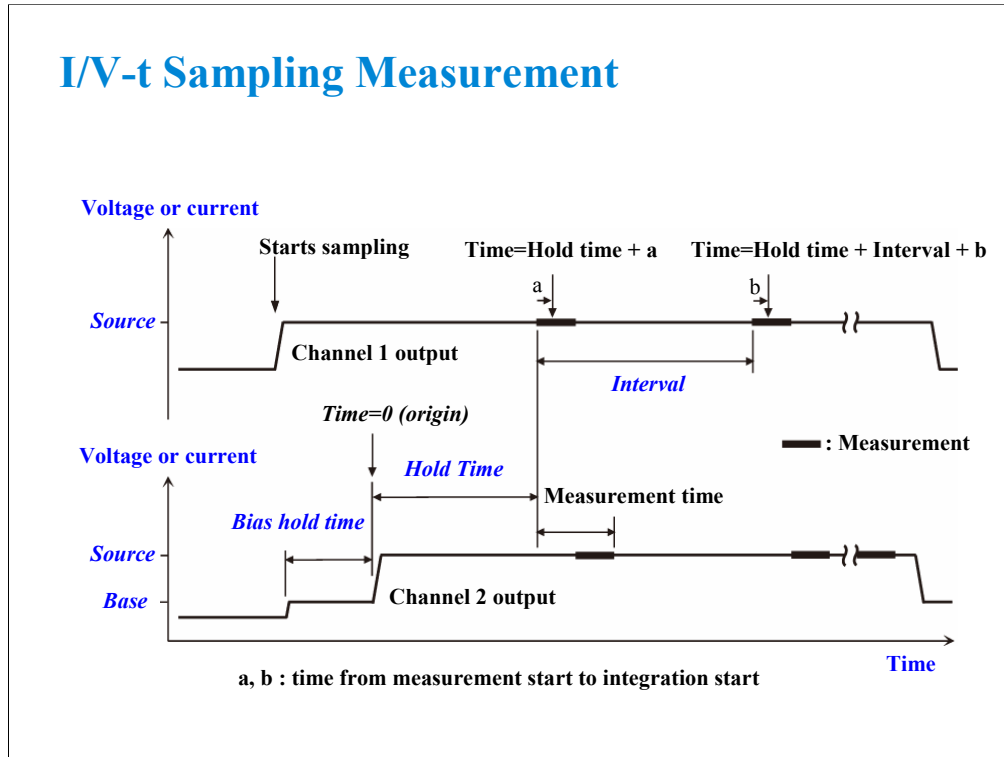

B1500 supports the sampling measurement which performs the operation shown above.

With the SEQUENTIAL output sequence, the source channels start to force the Source value sequentially. Then the last source channel forces the Base value, and forces the Source value after the Bias hold time. After the Hold time, the measurement channels start measurement sequentially, and repeat this in the specified interval if the measurement channel is ready to measure. After the last sampling measurement, the source channels stop output sequentially.

The order of source output is defined in the Channel Setup. Top of the channels on the setup screen starts output first. And the following channels start output sequentially. After the measurement, the source channels stop output sequentially in the opposite order.

With the SIMULTANEOUS output sequence, the source channels start to force the Base value simultaneously. And the channels force the Source value after the Base hold time. After the Hold time, the measurement channels start measurement sequentially, and repeat this in the specified interval if the measurement channel is ready to measure. After the last sampling measurement, the source channels stop output simultaneously.

For the measurement channels which use the high resolution A/D converter, the order of measurement is defined in the SMU Range Setup. Top of the channels on the setup screen starts measurement first. And the following channels start measurement sequentially. For the measurement channels which use the high speed ADC, the channels start measurement simultaneously.

I/V-t Sampling Measurement

- LINEAR
 - Sampling interval: ≥ 2 ms
0.1 ms to 1.99 ms (limited)
 - Number of samples: 1 to 100001
- LOG
 - Sampling interval: ≥ 2 ms
 - Number of samples: 1 + number of data for 11 decades
 - Remaining data:
10/25/50/100/250/500 data are plotted into one decade
of the log scale in the same distance

There are two sampling mode. The linear sampling repeats the sampling in the specified interval until the number of measurement data reaches the specified number of samples. High speed sampling is available if the following conditions are satisfied. The high speed sampling allows you to set the sampling interval 0.1 ms to 1.99 ms in 0.01 ms step.

1. Sampling mode is LINEAR
2. High speed ADC is used for all measurement channels
3. Interval ≥ 0.08 ms + 0.02 x (number of measurement channels) ms

The log sampling repeats the sampling in the specified interval and gathers the measurement data which can be plotted on the log scale in the same distance. The sampling will be stopped when the number of measurement data reaches the specified number of samples.

Class Exercise

Sampling Measurement

You will:

- Monitor the charging voltage of an RC circuit
- Learn LOG10 data interval
- Learn how to properly define a sampling algorithm

To Get Started:

- Use the instrument setup as same as the SMU pulse exercise
- Connect the RC components as shown in the next page
- Get and run the RC-sampling-log setup
- Change the range or ADC and perform append measurement

Jumper Leads – Sampling Exercise

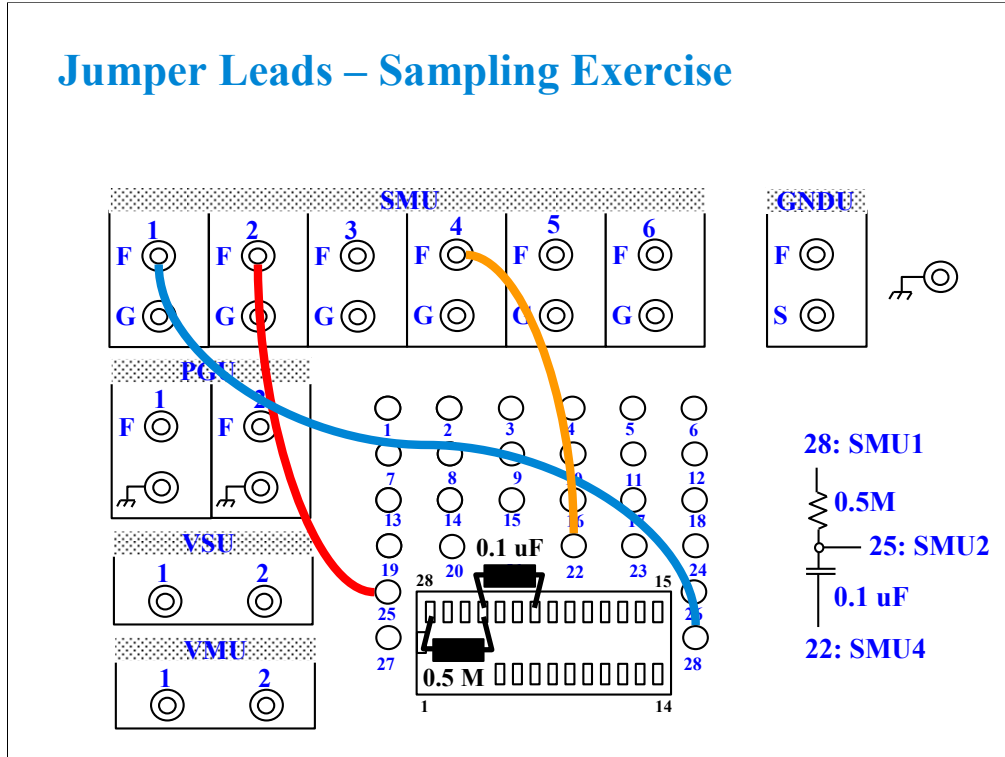

The 0.5 M ohm and 0.1 uF values were chosen because these values are readily available, and they give a RC time constant suitable for observing 2 ms time steps.

Sampling Exercise – LOG10, 2 ms interval RC Measurement

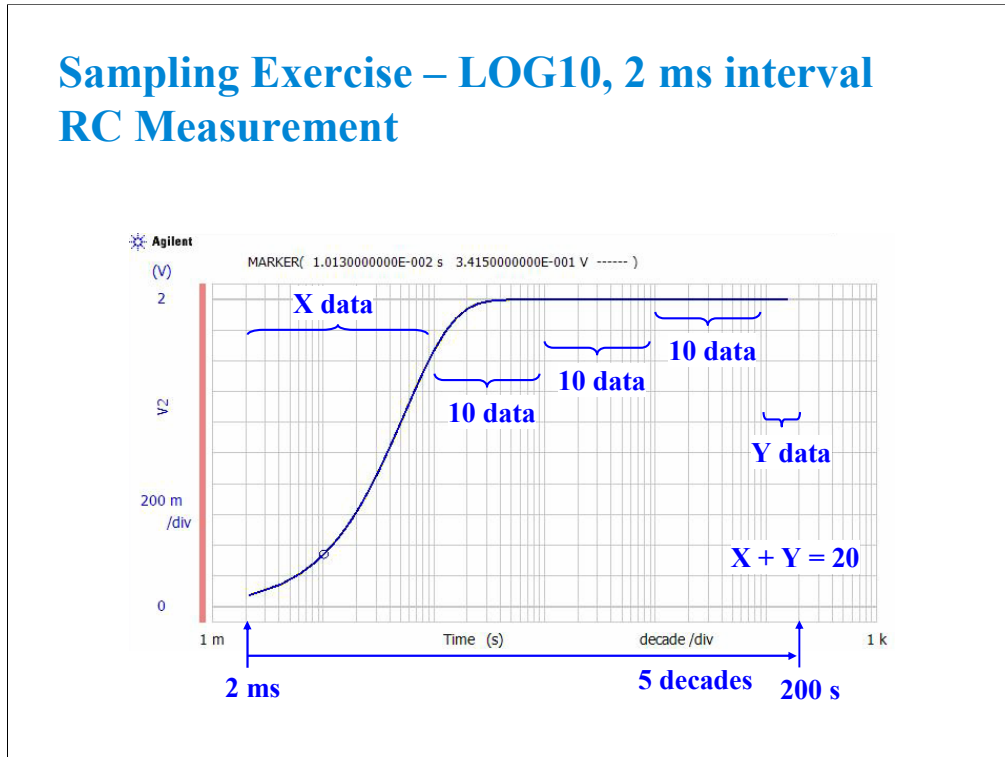

The RC-sampling-log setup is for the LOG10 sampling with 2 ms interval and 51 samples.

LOG10 sampling obtains 10 data in one decade. And the data will be plotted on the log scale in the same distance. However this rule cannot be kept at the beginning of sampling because of long interval.

In this example, there are 10 data in each decade from 100 ms to 10 s, and 20 data in the remaining decades. The first data will be near zero second. See the List Display.

Sampling Exercise – LOG10, 2 ms interval

Index	Time	V2
19	100.13 ms	1.6674 V
20	126.13 ms	1.7874 V
21	158.14 ms	1.8764 V
22	200.13 ms	1.9385 V
23	252.13 ms	1.9727 V
24	316.13 ms	1.9886 V
25	400.13 ms	1.9959 V
26	502.13 ms	1.9983 V
27	632.13 ms	1.9989 V
28	796.13 ms	1.9992 V
29	1.00213 s	1.9996 V
30	1.26213 s	2 V
31	1.58813 s	1.9999 V
32	2.00013 s	2 V
33	2.51813 s	2.0004 V
34	3.17013 s	2.0001 V
35	3.99013 s	2.0004 V
36	5.02413 s	2.0001 V
37	6.32413 s	2.0003 V
38	7.96213 s	2.0004 V
39	10.02413 s	2.0002 V
40	12.62013 s	2.0003 V
41	15.88613 s	2.0002 V
42	20.00013 s	2.0002 V
43	25.17813 s	2.0003 V
44	31.69813 s	2.0001 V
45	39.90613 s	2.0003 V
46	50.23813 s	2.0002 V
47	63.24613 s	2 V
48	79.62213 s	2.0003 V
49	100.23813 s	2.0002 V

10 data/decade

10 data/decade

10 data/decade

Sampling Exercise Channel Setup

I/V-t Sampling Setup Name: RC-sampling-log

Channel Setup | Measurement Setup | Function Setup | Auto Analysis Setup | Display Setup

Channel Definition

Add Delete Up Down

Unit:	V Name:	I Name:	Mode:
SMU1:HP	V1	I1	V
SMU2:HP	V2	I2	I
SMU4:HR	V3	I3	COMMON

Miscellaneous Variables

Time Stamp Name: Time Index Name:

Variable for time data

Sampling Exercise Measurement Setup

I/V-t Sampling

Channel Setup | Measurement Setup | Function Setup | A

Sampling Parameter

Linear/Log: LOG10

Interval: 2 ms

No of Samples: 51

Total Sampling Time: 158.866 s

Output Sequence: SIMULTANEOUS

Hold Time: 0 s

Base Hold Time: 0 s

Constants

Unit:	V Name:	I Name:	Mode:	Base:	Source:	Compliance:
SMU1:HP	V1	I1	V	0 V	2 V	100 mA
SMU2:HP	V2	I2	I	0 A	0 A	3 V

SMU Range Setup

Measurement Range

Unit:	Name:	Mode:	Range:	Range Change Rule:	Rate:
SMU1:HP	I1	LIMITED	1nA	BY FULL RANGE	High
SMU2:HP	V2	FIXED	2V		
SMU4:HR	I3	LIMITED	1nA		

A/D Converter & Integration Time Setup

A/D Converter

Unit:	Name:	ADC:
SMU1:HP	I1	HR ADC
SMU2:HP	V2	HS ADC
SMU4:HR	I3	

Integration Time

Mode:	Factor:	Auto Zero:
High Resolution ADC: AUTO	6	OFF
High Speed ADC: AUTO	1	

Use the FIXED range and the high speed A/D converter to get 2 ms interval.

Change the range to AUTO. Or change the ADC to the high resolution ADC. And perform append measurement. You may not get 2 ms interval at the beginning of sampling.

Negative Hold Time Available for Interval < 2 ms

-90 ms =< Hold Time =< -0.1 ms, 0.1 ms step

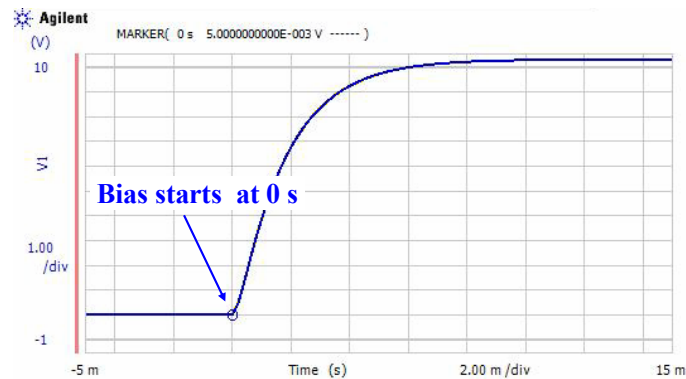

For the sampling measurement, the available hold time value is 0 to 655.35 s, in 10 ms step.

However, the negative hold time -90 ms to -0.1 ms, in 0.1 ms step is also available for the high speed sampling which the Interval is less than 2 ms.

This measurement result example is obtained by the setup shown in the following pages.

Jumper Leads – Negative Hold Time

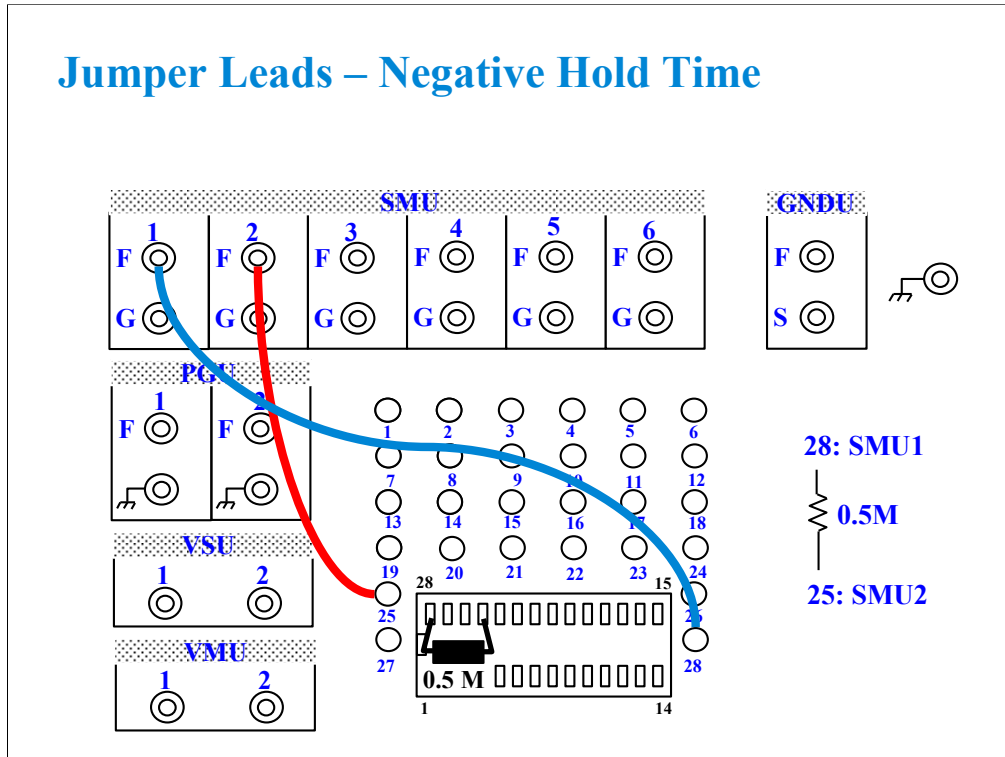

Negative Hold Time Channel and Measurement Setup

The screenshot displays the 'I/V-t Sampling' configuration window for a setup named 'R-samp1-neg-hold'. It is divided into two main sections: 'Channel Definition' and 'Sampling Parameter'.

Channel Definition: This section lists two channels. Channel 1 (SMU1:HP) is configured with V Name 'V1', I Name 'I1', and Mode 'I'. Channel 2 (SMU2:HP) is configured with V Name 'V2', I Name 'I2', and Mode 'COMMON'. A blue box highlights the 'Mode' dropdown for Channel 1, with the text 'Current source' next to it.

Sampling Parameter: This section contains the following settings:

- Linear/Log: LINEAR
- Interval: 200 us (highlighted with a blue box and the text 'Interval < 2 ms')
- No of Samples: 101
- Total Sampling Time: 20 ms
- Output Sequence: SIMULTANEOUS
- Hold Time: -5 ms (highlighted with a blue box and the text 'Negative Hold Time')
- Base Hold Time: 0 s

Constants: A table at the bottom summarizes the channel settings:

Unit:	V Name:	I Name:	Mode:	Base:	Source:	Compliance:
SMU1:HP	V1	I1	I	0 A	20 uA	20 V

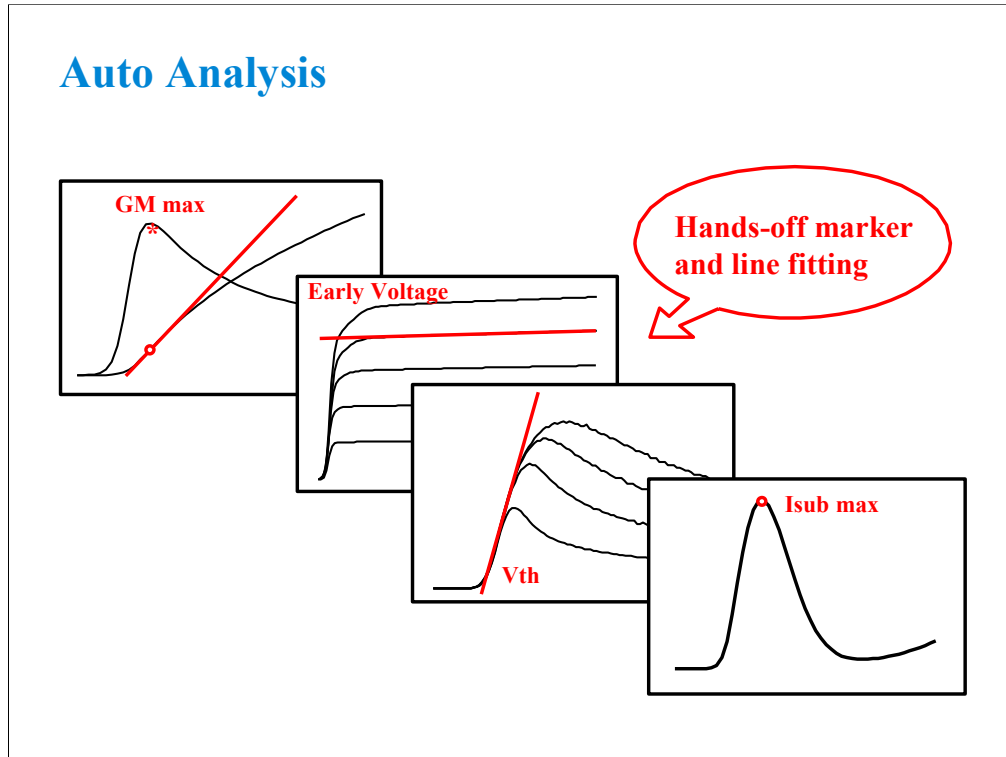

Auto analysis automates the task of doing scalar calculation on swept data. Computed parameters such as V_{th} or GM_{max} can be displayed in the Parameters area on the Data Display window. The built-in user functions allow data to be plotted and analyzed according to any arbitrary formula. The B1500 has built-in functions such as axis intercepts, logs, regression lines, area integration, max/min, and many more. The ability to automatically extract important parameters such as threshold voltage without the need to manually manipulate screen cursors or markers is important in process development.

Auto Analysis Vth Example

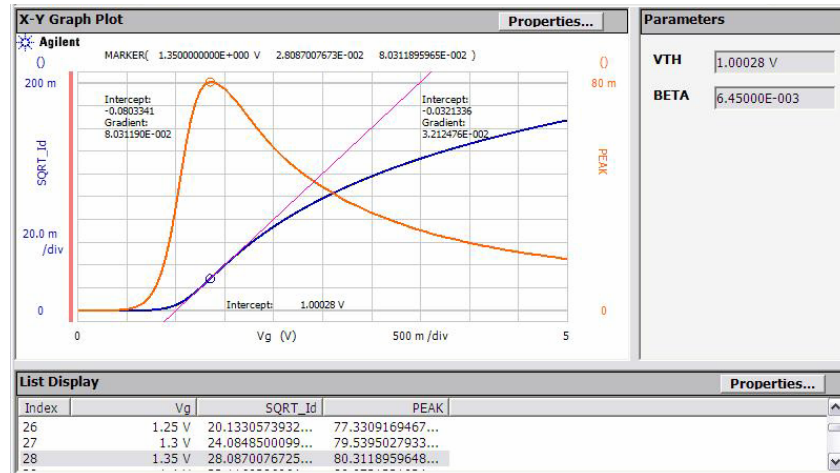

Here we see a full-featured example of auto analysis. GMmax and Vth are automatically calculated each time a measurement is made. Even if you alter the analysis, say by moving the line, you can restore the original analysis by clicking the Apply button on the Auto Analysis Setup screen.

IMPORTANT!

Please note that formulas for auto analysis are not hard coded into the B1500. You define the formulas, and so you can customize the method of performing the analysis.

V_{th} Measurement A Tedious Process Now Automated

- Plot square root of the drain current (SQRT Id)
- Plot rate of change of SQRT Id (PEAK)
- Find Peak Value of the PEAK plot
- Drop down to the SQRT Id plot
- Draw a tangent line on the SQRT Id plot
- Read the X-intercept of the tangent line as V_{th22}

In the previous example of graphically determining V_{th}, the above steps were automated. There are other definitions of V_{th} which are less complex, but now you don't have to worry about complexity. The B1500 can perform the process without you having to interact with the screen.

Not only automation removes human error, but also it allows computer controlled analysis to proceed without interruption.

Class Exercise

Auto Analysis

You will:

- Make a MOS threshold voltage (V_{th}) measurement
- Observe how parameters for the analysis are defined
- Observe how the user functions and analysis functions are used in the analysis

To Get Started:

- Use the standard MOS device and pin connections
- Get the GMMAX setup
- Make a measurement and turn the knob
- Click the Apply button to restore the analysis

In this exercise you will observe how auto analysis works. You will understand each setup screen required to implement an auto analysis process.

V_{th} Measurement Damaged MOS FET Device?

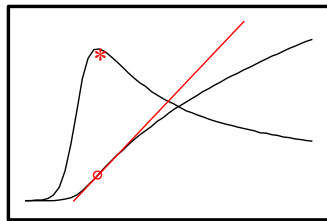

Good
Continuous Curve
No Static Damage

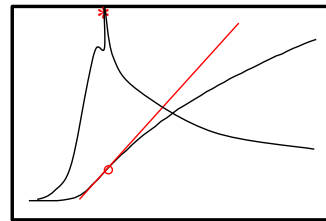

BAD
Broken-Lumpy Curve
Severe Static Damage

The class exercise uses a packaged MOS FET device which is very susceptible to static damage. If the device has been handled or moved in and out of the socket a few times, you may see a BAD response as indicated above. Replace the device with a new one.

At the wafer level, you can have the same problems. Putting a charged probe with cables attached down on a gate junction can weaken or destroy the device. Also, the B1500 offset cancel (zero cancel) sends signals down to the probes. These voltages can damage a sensitive gate junction.

Vth Measurement Channel and Measurement Setup

VAR1

Unit: SMU3:HR

Name: Vg

Direction: Single

Linear/Log: LINEAR

Start: 0 V

Stop: 5 V

Step: 50 mV

No of Step: 101

Compliance: 100 mA

Pwr Comp: OFF

Channel Definition

Unit:	V Name:	I Name:	Mode:	Function:
SMU1:HP	Vsub	Isub	V	CONST
SMU2:HP	Vs	Is	COMMON	CONST
SMU3:HR	Vg	Ig	V	VAR1
SMU4:HR	Vd	Id	V	CONST

Timing

Hold: 0 s Delay: 0 s * Sweep: CONTINUE AT ANY status

Constants

Unit:	V Name:	I Name:	Mode:	Source:	Compliance:
SMU1:HP	Vsub	Isub	V	0 V	100 mA
SMU4:HR	Vd	Id	V	2 V	100 mA

Nothing new here. This slide is included for completeness. You will notice that these variables are heavily used on the Function Setup screen.

Vth Measurement Function Setup

The screenshot shows two windows for setting up measurement functions. The top window is titled "User Function" and contains a table with columns for Name, Unit, and Definition. It lists two functions: Sqrt_Id and PEAK. The bottom window is titled "Analysis Function" and contains a table with columns for Name, Unit, and Definition. It lists two functions: VTH and BETA.

User Function		
Name:	Unit:	Definition:
Sqrt_Id		sqrt(Id)
PEAK		diff(Sqrt_Id,Vg)

Analysis Function		
Name:	Unit:	Definition:
VTH	V	@L1X
BETA		@L1G^2

Here are definitions for the Y1-axis plot (SQRT_ID) and the Y2-axis plot (PEAK).

@L1X means the X-axis intercept of LINE 1.

@L1G^2 means the squared gradient value of LINE 1. In this case, it is just calculating line 1 slope. It is squared to account for the fact that the Y1-axis is a square root.

Click Help > Agilent EasyEXPERT Help to open the online help. And visit the Read Out Functions page for all of these functions.

Vth Measurement Display Setup Page

The screenshot displays the 'Vth Measurement Display Setup Page' interface. It is divided into three main sections:

- X-Y Graph:** This section contains a table for defining measurement data series. It includes columns for Name, Scale, Min, and Max. The 'X' series is selected with a checkmark and has a Name of 'Vg', a Scale of 'Linear', and Min/Max values of '0 V' and '5 V'. The 'Y1' series is unselected and has a Name of 'SQRT_Id', a Scale of 'Linear', and Min/Max values of '0' and '0.2'. The 'Y2' series is unselected and has a Name of 'PEAK', a Scale of 'Linear', and Min/Max values of '0' and '0.08'. Buttons for 'Add', 'Delete', 'Up', and 'Down' are located at the top of this section.
- List Display:** This section contains a list of variables to be displayed. It includes buttons for 'Add', 'Delete', 'Up', and 'Down'. The variables listed are 'Vg', 'SQRT_Id', and 'PEAK', each with a radio button next to it.
- Parameters:** This section contains a list of parameters to be displayed. It includes buttons for 'Add', 'Delete', 'Up', and 'Down'. The parameters listed are 'VTH' and 'BETA', each with a radio button next to it.

VTH and BETA are values which will be displayed at the Parameters area on the Data Display window.

These variables are defined in the Function Setup screen.

Auto Analysis Analysis Setup Page

The screenshot displays the 'Auto Analysis Analysis Setup Page' with three main sections: Line 1, Line 2, and Marker.

Line 1:

- Enable
- Type: Normal Gradient Tangent Regression
- Axis: Y1
- First Point: X-Y Coordinate Data Condition
- Condition: PEAK = max(PEAK) After
- Second Point: X-Y Coordinate Data Condition
- X: Y:

Line 2:

- Enable
- Type: Normal Gradient Tangent Regression
- Axis: Y1
- First Point: X-Y Coordinate Data Condition
- X: Y:
- Second Point: X-Y Coordinate Data Condition
- X: Y:

Marker:

- Enable
- Condition: PEAK = max(PEAK) After

This screen is the heart of auto analysis. You define custom procedures for graphical analysis with fill-in-the-blank ease.

(End of This Class Exercise)

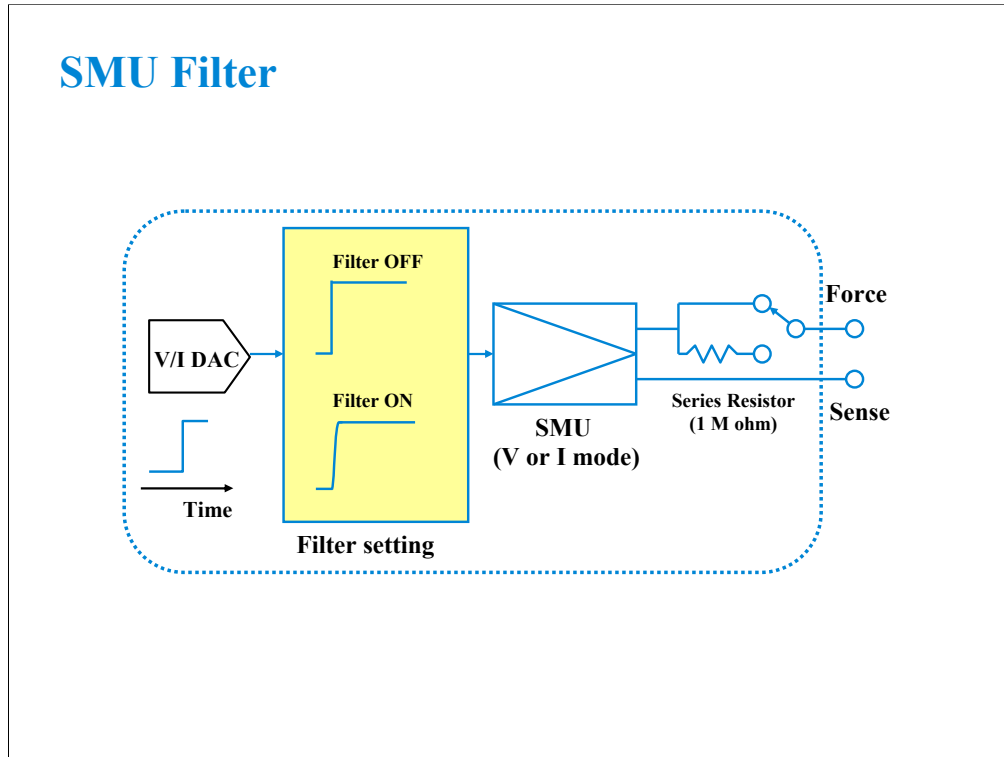

The filter is mounted on each SMU. It assures clean source output with no spikes or overshooting. However, using a filter may increase the SMU settling time. If measurement speed is top priority, set the SMU Filter OFF.

SMU Filter

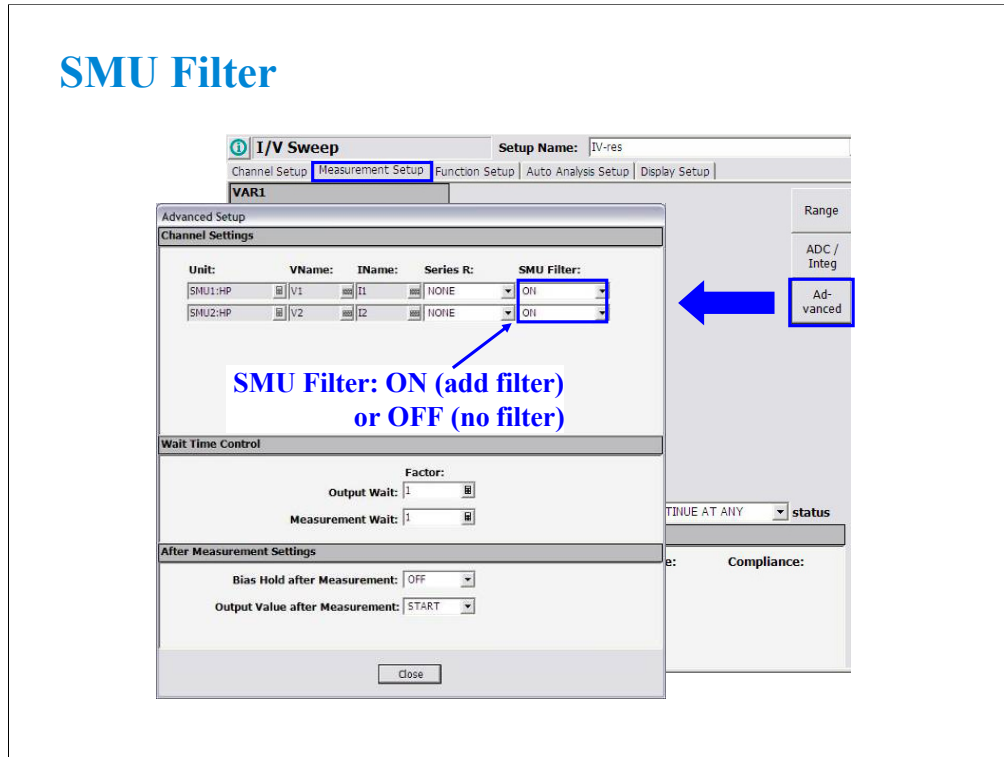

To change the SMU filter setup, open the Advanced Setup window by clicking the Advanced button on the Measurement Setup screen. And specify ON or OFF by using the SMU Filter pull down menu.

In the power on state, the Classic Test sets the SMU Filter to ON.

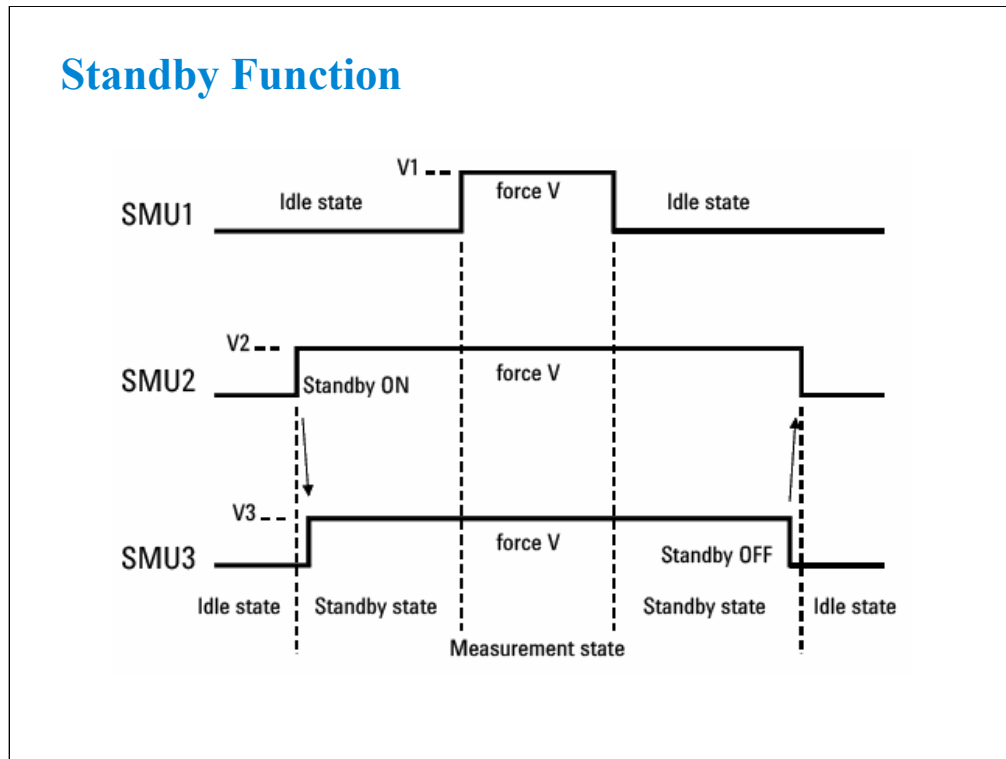

Standby function sets any SMUs (except HRSMU with ASU) to specific output values and compliances before starting or after stopping measurement. Standby function is useful for power supplies of complicated device (eg. Smart TEG), defect analysis, and so on.

This slide shows the standby and measurement operation in the following setup. This example assumes that the channel setup is defined in the Standby Channel Definition as follows in the order, and the output value in the standby state is the same as the output value in the measurement state.

- SMU1: Voltage source, non-standby channel
- SMU2: Voltage Source, standby channel
- SMU3: Voltage Source, standby channel

To Use Standby Function

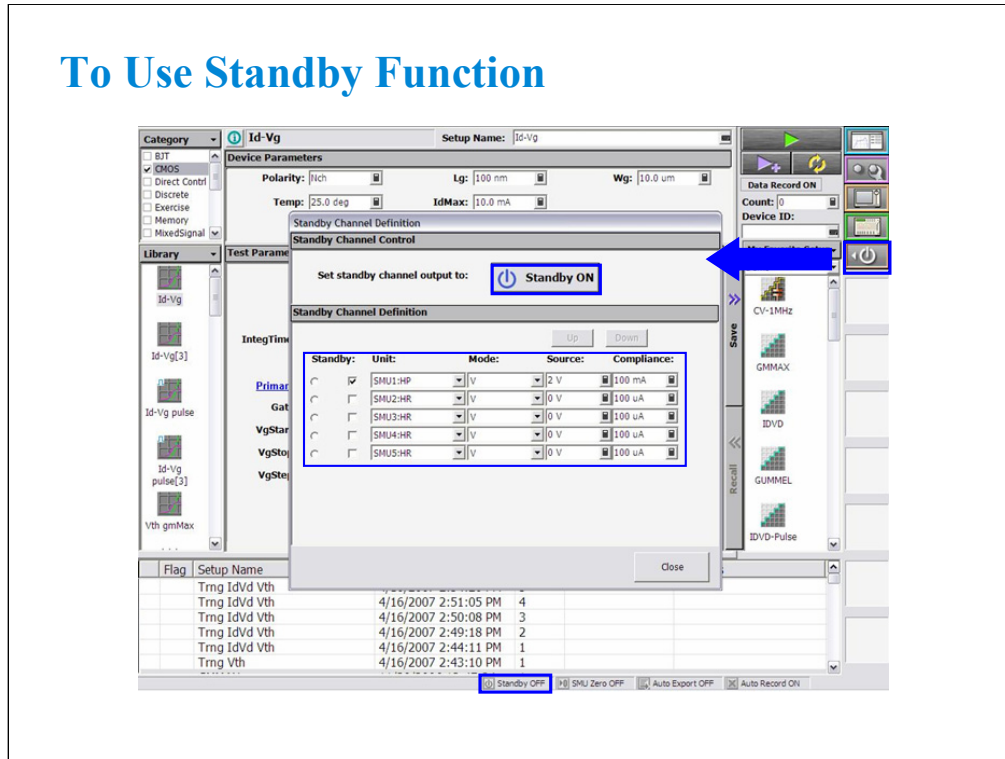

Click the Standby Channel Definition button to open the Standby Channel Definition window.

Define Standby channels (Unit, Mode, Source, and Compliance).

Click the Standby ON button to set standby channel outputs. The Standby indicator will change from OFF to ON.

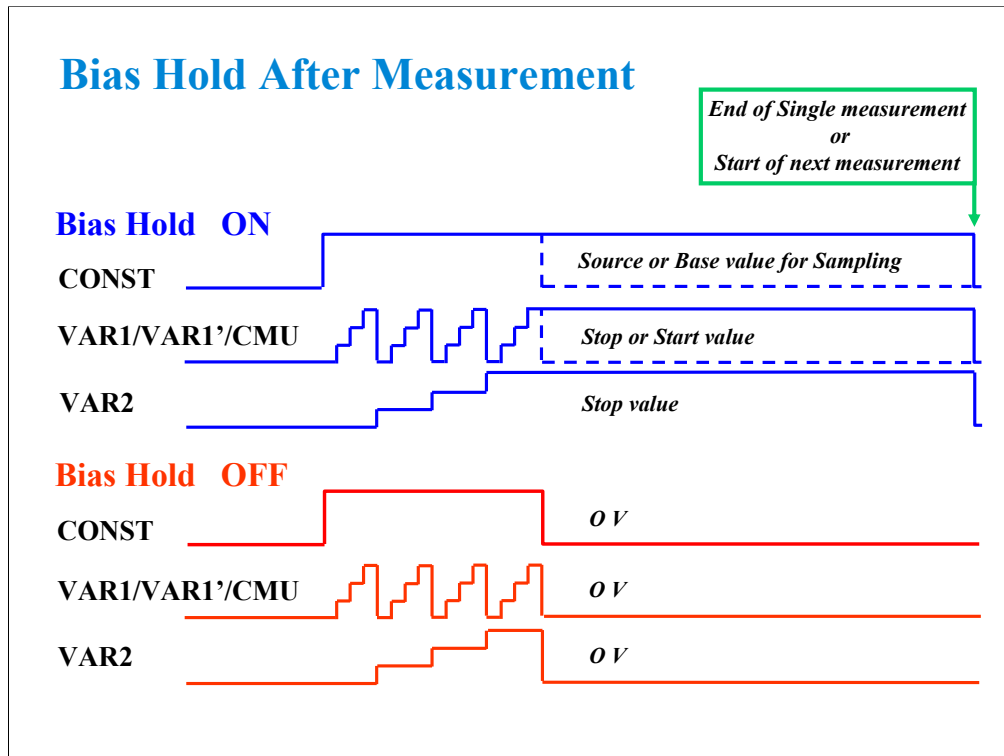

Bias hold function keeps bias output after a measurement is made. For instance, the user may need to keep one or more SMUs on between measurements to bias up a Vcc pin of an IC. Without this function, a user is forced to connect an external power supply. Now there is no need for extra supplies.

When this function is ON, the source channels apply the following value.

Constant source:	Base value or Source value (I/V-t sampling)
Constant source:	Source value (I/V Sweep or C-V Sweep)
VAR1/VAR1' source:	Start value or Stop value (I/V Sweep)
VAR2 source:	Stop value (I/V Sweep)
CMU:	Start value or Stop value (C-V Sweep)

Class Exercise

Bias Hold Function

You will:

- Perform Repeat Measurement
- Measure the LED I-V characteristics
- Monitor LED during Repeat Measurement

To Get Started:

- Use the connection as same as the SMU pulse exercise
- Add an LED and jumper leads per following pages
- Get the LED setup

Jumper Leads – Bias Hold Exercise

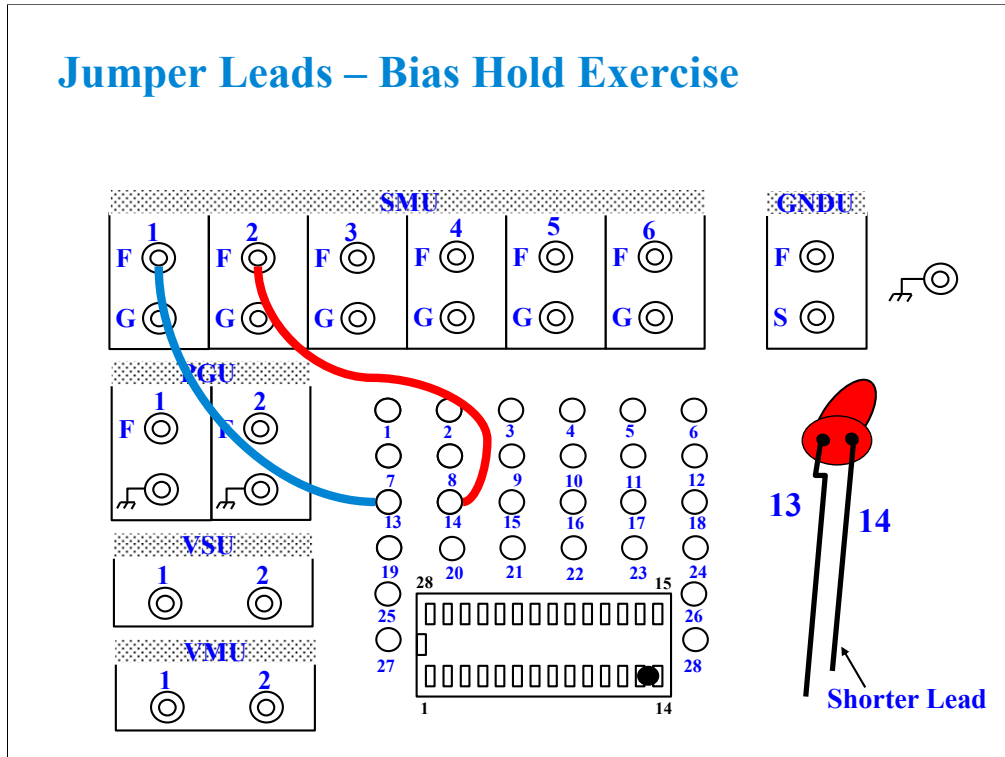

Connect test leads as shown. And add the LED between terminals 13 and 14 of the 28-pin dual in line socket.

Bias Hold Exercise Channel and Measurement Setup

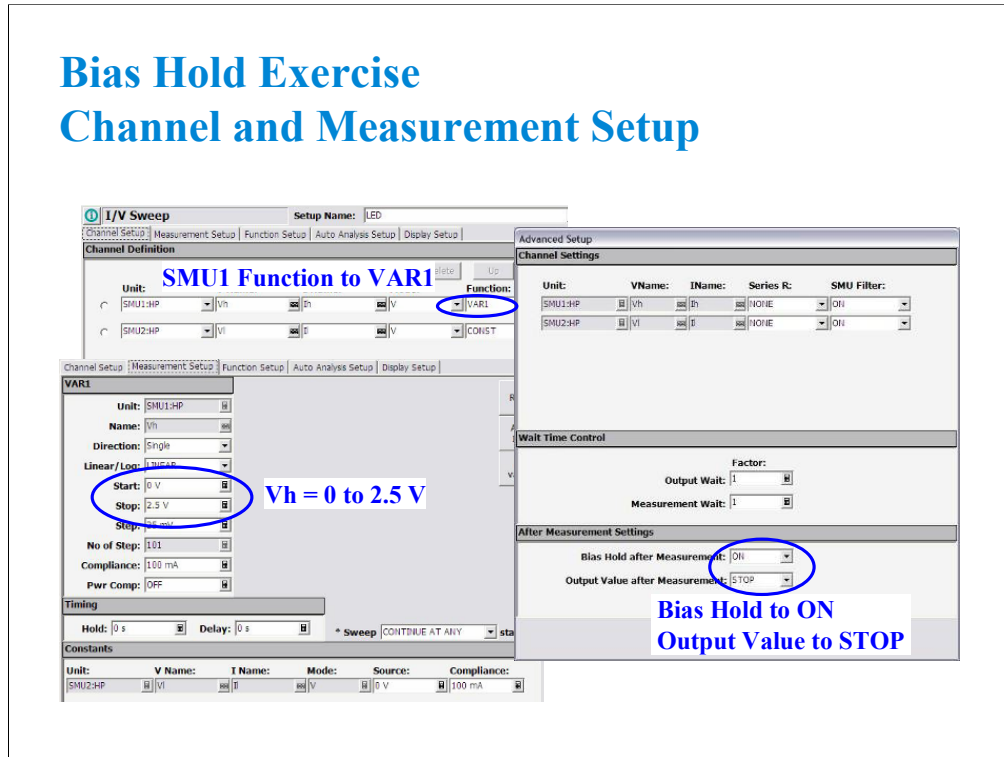

Set the SMU1 Function to VARI. The VARI output 0 to 2.5 V is enough to light the LED.

Set the Bias Hold after Measurement field to ON to enable the bias hold function. And set the Output Value after Measurement field to STOP. This setup keeps 2.5 V output between sweep measurements. So the LED can light between the measurements.

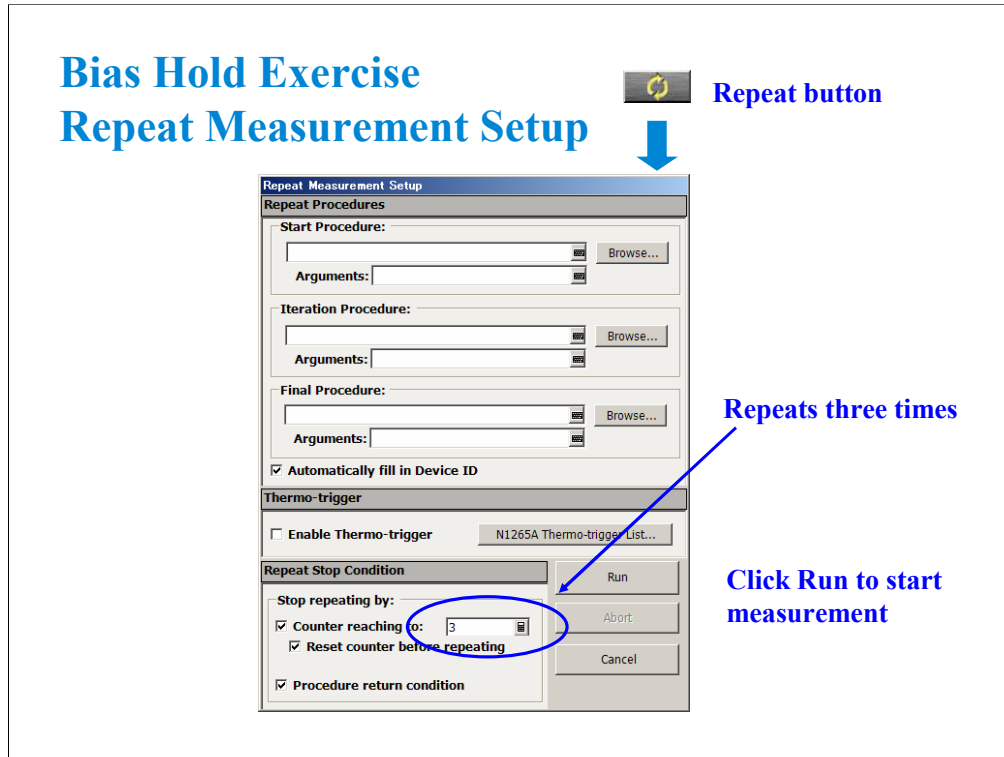

Click Repeat button to open this window which is used to set and run the repeat measurement.

This example performs the LED I-V sweep measurement three times and then finishes the repeat measurement.

Bias Hold Exercise

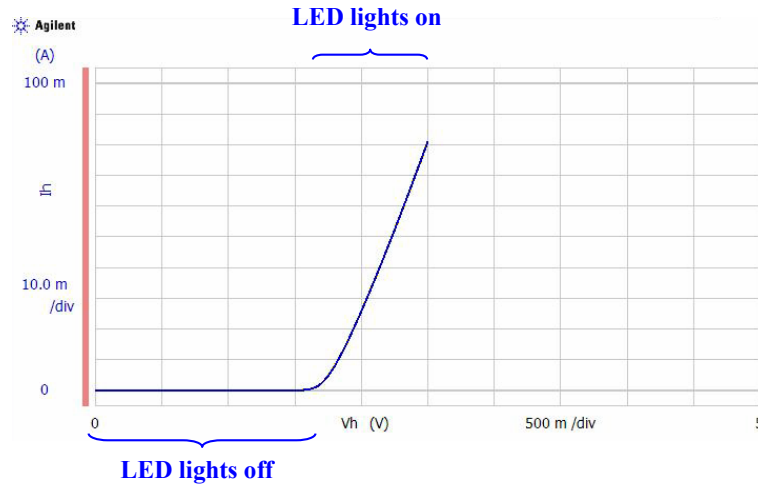

During the measurement, leave the fixture lid open. And monitor the LED. This measurement does not force dangerous voltage.

At the start of measurement, LED lights off. Beyond the threshold voltage, the LED lights on. After the measurement, the LED keeps lighting until start of the next sweep measurement. And this cycle is repeated until the end of the repeat measurement. After the repeat measurement, the LED lights off.



5

Modifying Application Test Definitions



In This Module

- **To Open Application Test Definition**
- **To Modify Test Definition**
- **To Use Debug Tools**
- **To Use Built-in Functions**
- **To Add Data Display**
- **To Use Auto Analysis**
- **To Use Test Setup Internal Variables**
- **To Use Auto Analysis twice (as Class Exercise)**
- **To Use Vector Data (as Class Exercise)**

Modification Overview

- 1. Open an application test definition to be modified**
- 2. Open test definition editor**
- 3. Save the definition as your test definition**
- 4. Modify the definition as you like**
- 5. Resave and close the definition**
- 6. Export your test definition as your backup**

This module explains the modification example using the Vth Const Id test definition. After the modification, the new definition can perform the Vth Const Id measurement, display the Id-Vg curve, and additionally display the gm-Vg curve.

To Open an Application Test Definition

Example: Select Vth Const Id as template

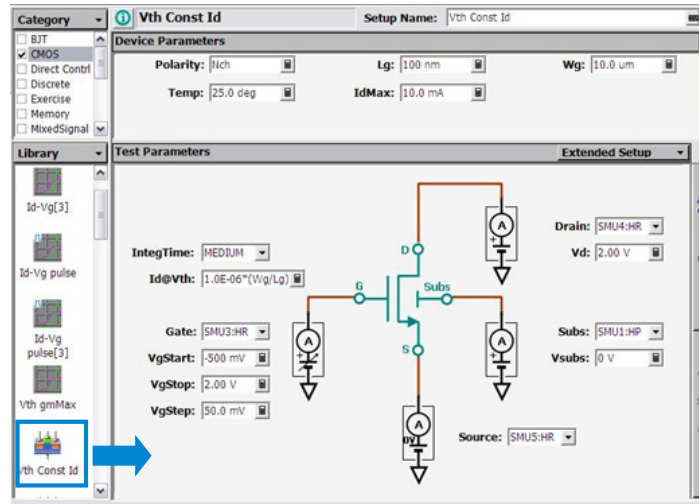

Click a test definition in Library list area, and click Select button to open the test definition.
For example, open Vth Const Id.

To Open Test Definition Editor

Click Library>Open Definition of This Test...

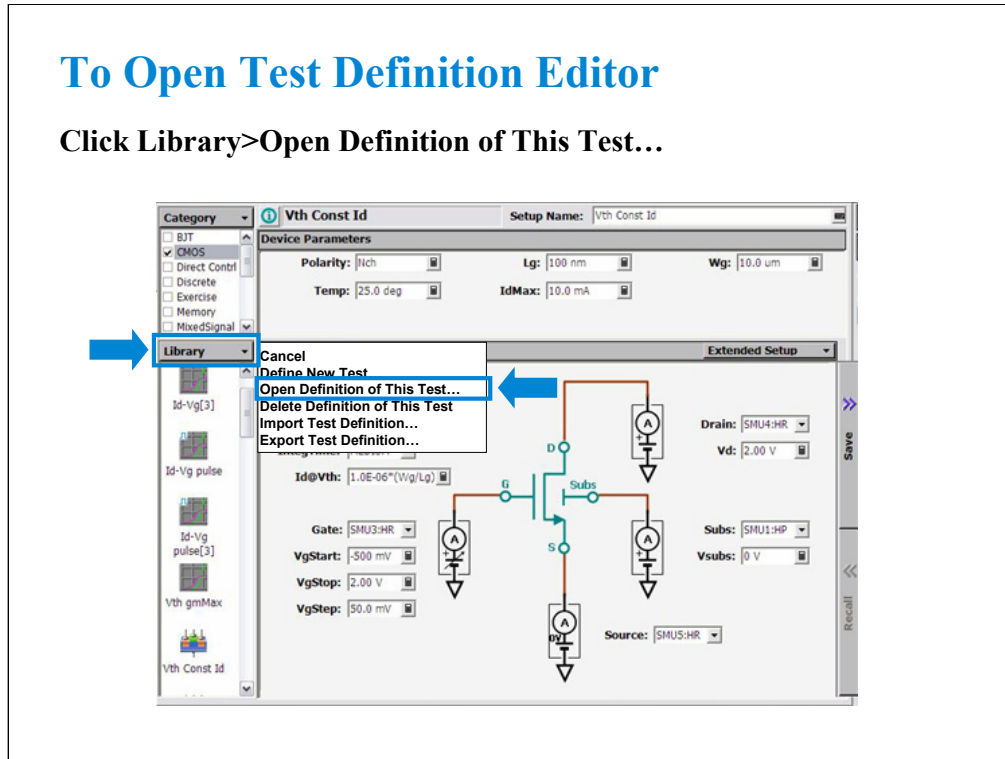

Click Library and select Open Definition of This Test... to open the test definition editor.

The following pages show the modification example to display the gm-Vg curve given by the Vth Const Id test result.

To Save Definition As Your Definition

Save the definition as your definition (ex: Trng vth)

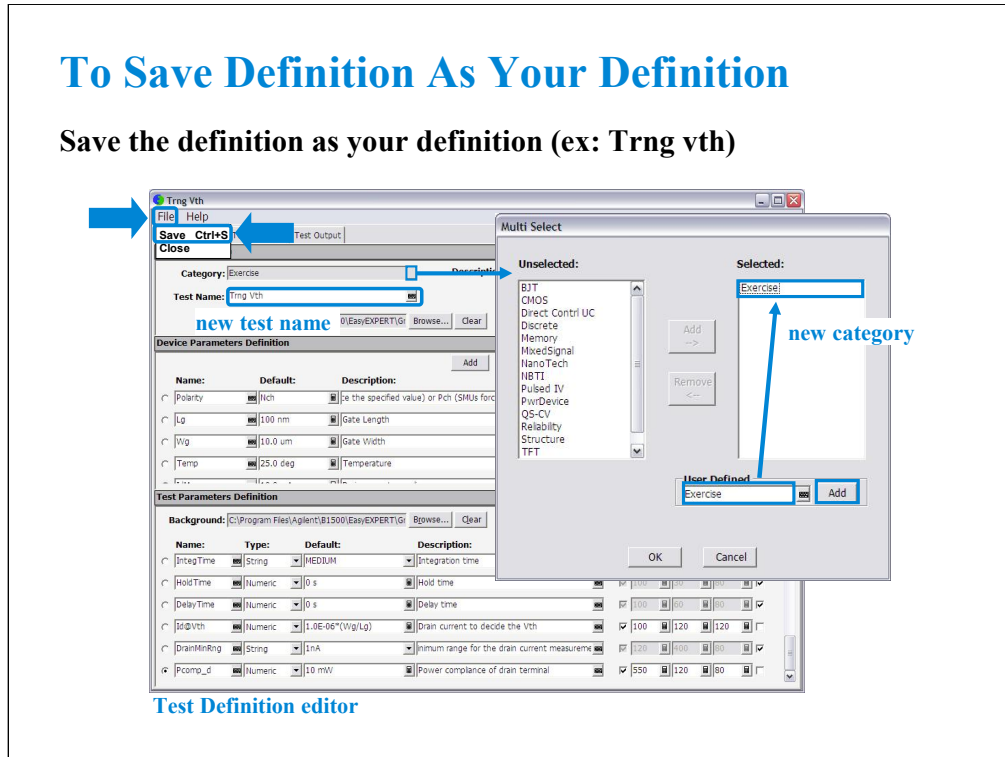

Create a new Category (ex. Exercise), and change the Test Name (ex. Trng Vth).

After changing the test name, save the test definition. Saving the definition will change the window title to the new test name. Window title will be changed from Vth Const Id to Trng Vth in this example.

In this example, the Trng Vth definition belongs to the Exercise category only.

To Modify Test Definition

Change default values and add parameters (ex: Pcomp_d)

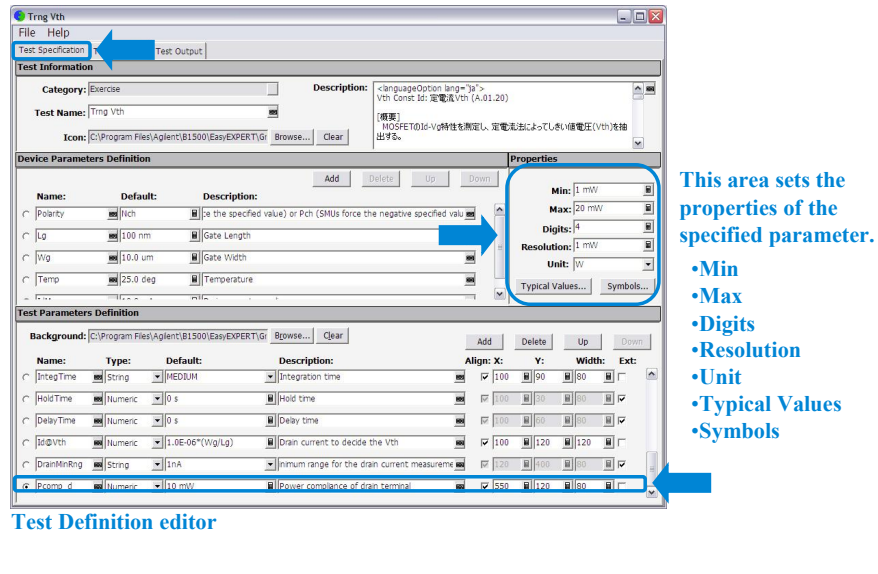

On the Test Specification tab screen, you can add new parameters or change parameter settings.

This example changes the default value of the Module parameters for the MOS FET class exercise typical setup and adds the Pcomp_d test parameter (drain terminal power compliance).

The Module parameter default values are changed as follows. See the actual settings on the test definition editor.

Drain: SMU4
Gate: SMU3
Source: SMU2
Subs: SMU1

The Pcomp_d parameter is defined as follows.

Name=Pcomp_d, Type=Numeric, Default=1 mW, Description=Power compliance for drain terminal, Align=check, X=550, Y=120, Width=80, Ext=unchecked

Properties: Min=1 mW, Max=20 mW, Digits=4, Resolution=1 mW, Unit=W

For Align, X, Y, and Width values, consult the settings of the other parameters for the same terminal (ex. Drain). For example, Pcomp_d must be located between Vd and Subs entry fields (see application test screen on the main window). So X and Width should be the same as the settings of Vd, and Y should be between 90 and 180 (see the actual settings of Vd and Subs on the test definition editor).

Typical Values... button opens a dialog box used to define the typical values used for the selections of the parameter value in the Application Test mode. For example, set 2 mW to 20 mW in 2 mW step for Pcomp_d.

Symbols... button opens a dialog box used to map a numeric value to a string. For example, Value=1 and Symbol=ON are set, typing ON enters 1, and typing 1 enters ON. The value must satisfy the Min, Max, Digits, and Resolution settings. The value and the symbol must be one by one. The definition is effective only for the parameter.

To Modify Test Definition

Change or set test parameters (ex: Pcomp_d)

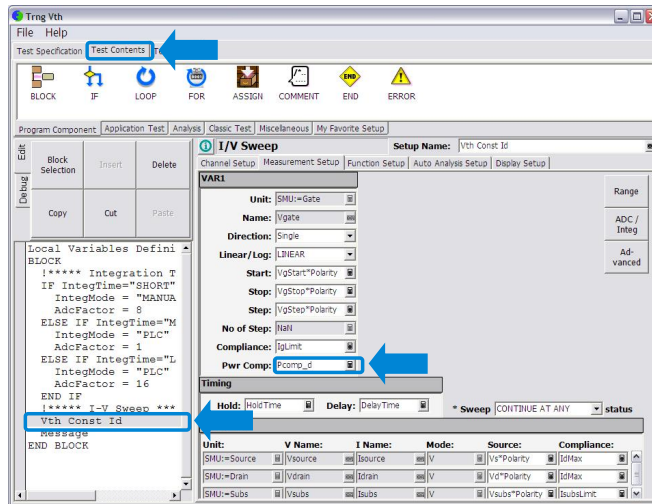

Test Definition editor

On the Test Contents tab screen, you can change the test execution flow (program flow), measurement conditions, display setup, and so on.

To add the Pcomp_d parameter to the measurement setup, click the Vth Const Id line in the program list. And in the I/V Sweep setup editor, display the Measurement Setup tab screen. And enter Pcomp_d to the Pwr Comp entry field.

To Modify Test Definition

Change display setup and define external variables

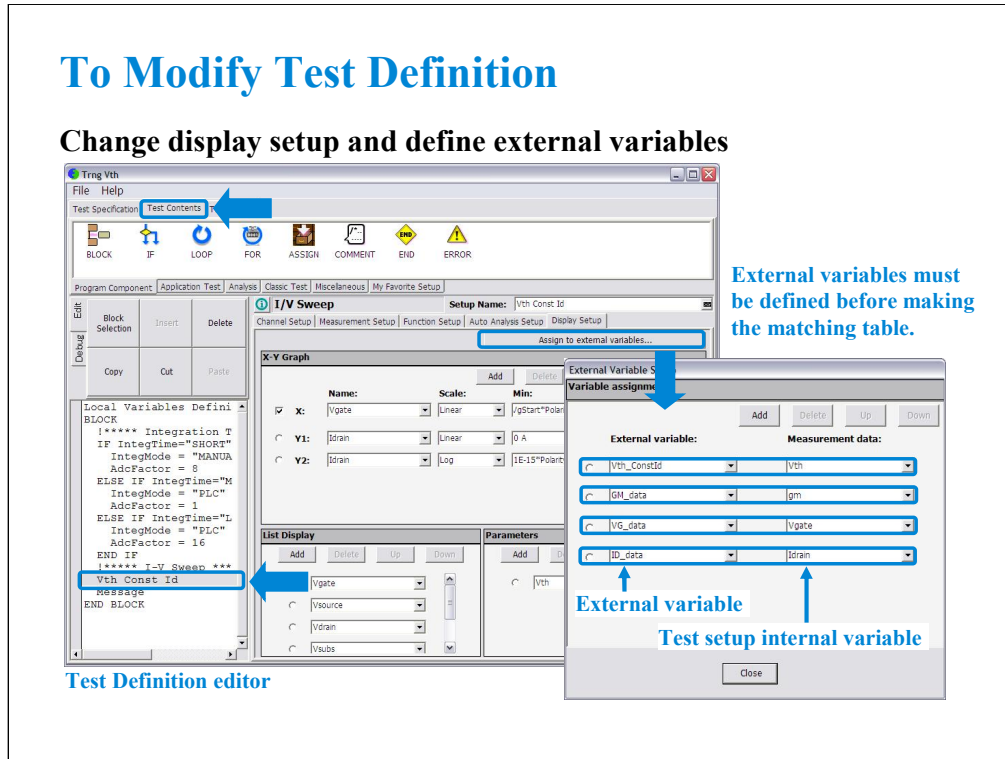

On the Display Setup tab screen, you can change the graph scale Min/Max values or add/delete the list parameters.

This example makes the matching table between the External variables and the Measurement data. The measurement data can be referred outside the test setup via the external variable.

Where, the measurement data means the variables used in the test setup. And the external variables means the parameters defined in the Test Specification, the Local Variable Definition, or the Test Output's Analysis Parameter Definition.

This example sets the matching table as follows.

Vth_constId external variable: Vth internal variable
 GM_data external variable: gm internal variable
 VG_data external variable: Vgate internal variable
 ID_data external variable: Idrain internal variable

External variables must be defined before making the matching table. In this example, the variables are defined in the Analysis Parameter Definition. See the next page.

To Modify Test Definition

Define Test Output and Analysis Parameters

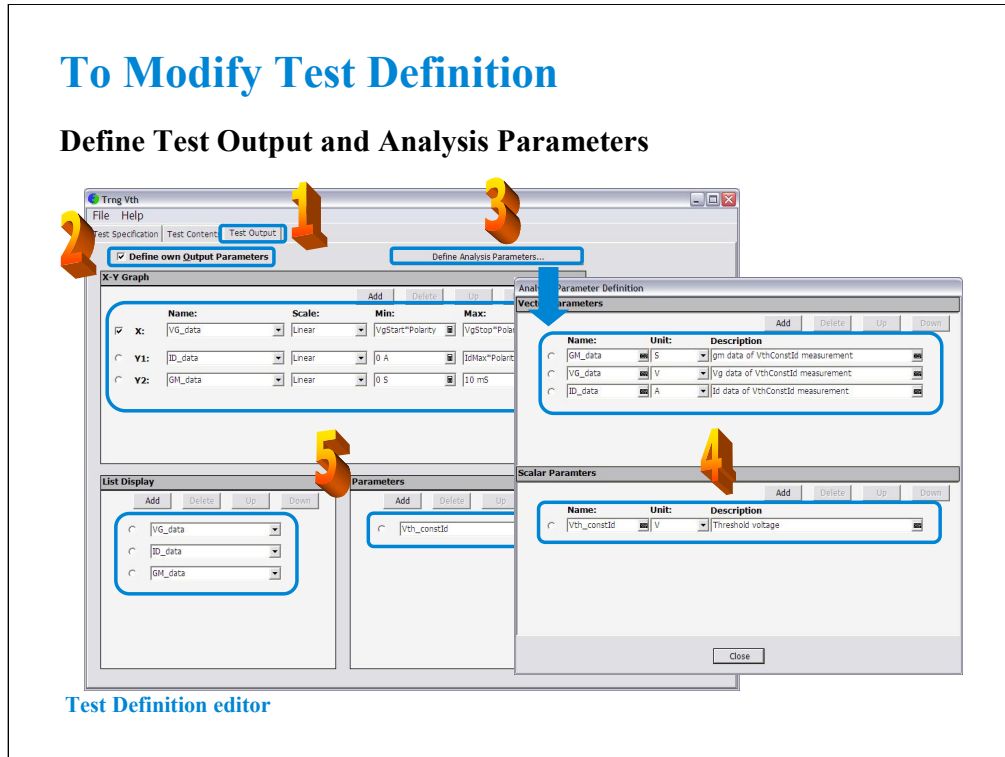

Test Definition editor

This example defines the Test Output and the Analysis Parameters.

1. Display the Test Output screen.
2. Check the Define own Output Parameters.
3. Click the Define Analysis Parameters button.
4. Define the analysis parameters (ex. GM_data, VG_data, ID_data, and Vth_constID).
5. Define the X-Y Graph, List Display, and Parameters.

Note

External variables must be defined before making the matching table shown in the previous page. In this example, the following parameters can be the external variables.

Parameters defined in the Test Specification

Variables defined in the Local Variable Definition

Variables defined in the Analysis Parameter Definition (this example)

Note

If this test definition is used in the other test definition, the analysis parameters can be referred outside this test definition. This means that the analysis parameters can be the Measurement data in the External Variable Setup as shown in the previous page.

To Modify Test Definition

Add local variable (ex: Yes for Message box)

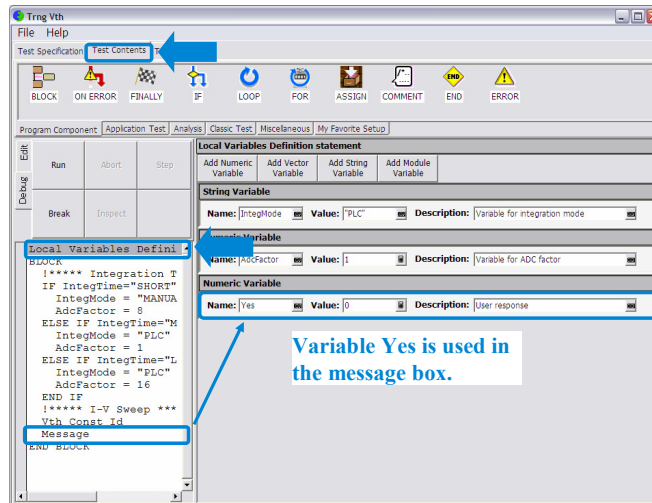

Test Definition editor

Click Local Variables Definition line to display the local variable list. And define variables.

This example defines Yes variable as follows. This variable is used in a message box. See the next page.

Name=Yes, Value=0, Description=User response

To Modify Test Definition

Define Message box

This message box asks you clicking the OK button to display the gm curve.

This setup displays the message "To display the gm curve, click OK." on the message box.

This setup makes the OK button on the message box.

The value of the local variable Yes is set to 1 from 0 by clicking the OK button.

Test Definition editor

Click the Message line in the program list. And define the message box.

This example defines the message box that opens after the Vth Const Id measurement and displays a message and the OK button.

1. Enter the message.
2. Enter the button name.
3. Select the variable used to keep the status of the button.
4. Repeat 2 and 3 for all buttons you want to add.

To Modify Test Definition

Example: Displaying Message box

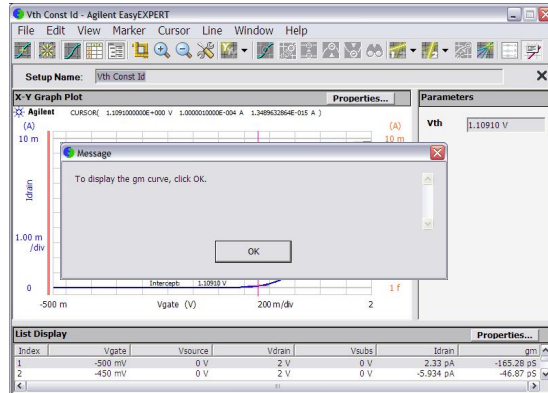

In this modification example, the message box opens after the Vth Const Id measurement is completed. This message box asks you clicking the OK button to display the gm curve.

Class Exercise

Perform the following modification example.

1. **Open Id-Vd test definition.**
2. **Modify it as follows.**
If Yes is clicked after Id-Vd test, move marker and tangent line to Vdrain=1 point.
If Yes is clicked, perform Vth gmMax test.
3. **Use the debug tools.**
4. **Save the definition as a new one (ex. Trng IdVd Vth).**
5. **Perform the test.**
6. **Export the new definition, and import it.**

1. Add the Yes variable to the Local Variable Definition.
2. Insert the following lines between the lines Id-Vd and END BLOCK.
Message
IF Yes=1
 Auto Analysis
END IF
Message
IF Yes=1
 Vth gmMax
END IF
3. Define the first message box.
Message: Do you perform auto analysis?
Button1 Label: Yes, Selected: Yes
Button 2 Label: No, Selected: (blank)
4. Define the second message box.
Message: Do you perform Vth gmMax test?
Button1 Label: Yes, Selected: Yes
Button 2 Label: No, Selected: (blank)
5. Define the IF statements.
Condition Expression: Yes=1
6. Define the Auto Analysis.
Line 1: Enable, Tangent, Axis: Y1, Data Condition: Vdrain=1
Marker: Enable, Condition: Vdrain=1
7. Change the Vth gmMax test parameters as follows.
Drain: Drain
Gate: Gate
Source: Source
Subs: Subs

To Use Debug Tools

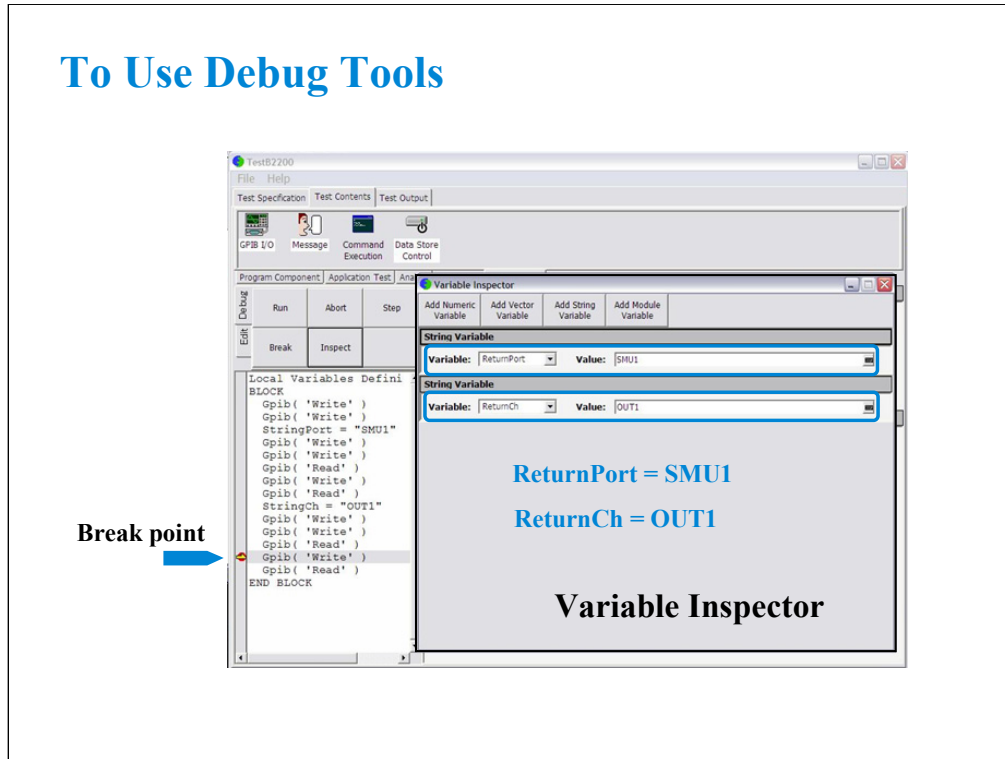

This slide shows an example of using the Variable Inspector for debugging. Confirm whether the correct values are passed to the variables properly.

Set the break point, and click the Run button. After the program is paused, click the Inspect button. The Variable Inspector is displayed. You can check the values by using the variable display fields. The field can be displayed by using the Add XXXX Variable button. XXXX will be Numeric, Vector, String, or Module.

To Use Debug Tools

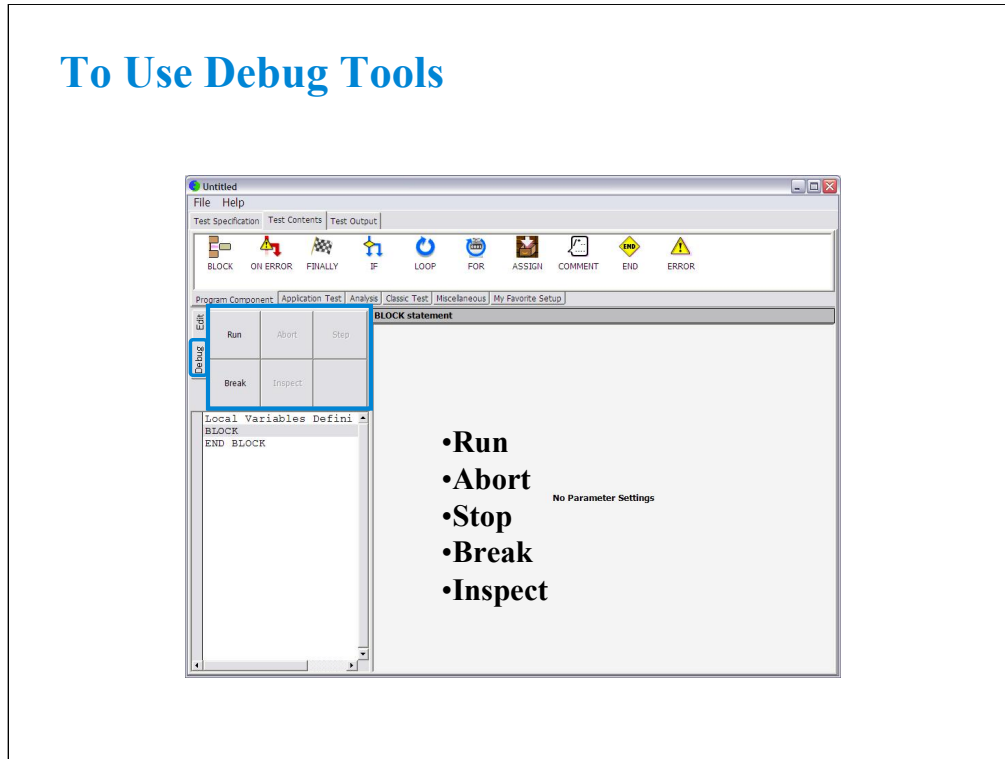

The Debug tab menu provides the following buttons:

- Run button starts the debug (executes the test flow). During execution, the label changes to Pause. Clicking Pause button pauses the execution, and changes the label to Run that is used to continue the debug (execution).
- Abort button aborts the debug (execution).
- Step button executes the highlighted line of the test flow. Clicking the button repeatedly continues the execution by a line.
- Break button sets/releases the break point. For the break point, this button releases the break point from the highlighted line. Program execution will break at the break point automatically.
- Inspect button is available when the debug (execution) is paused or broken. This button opens the Variable Inspector used to monitor value of device parameters, test parameters, analysis parameters, local variables, or system variables.

To Use Debug Tools

Debug: Inspect button

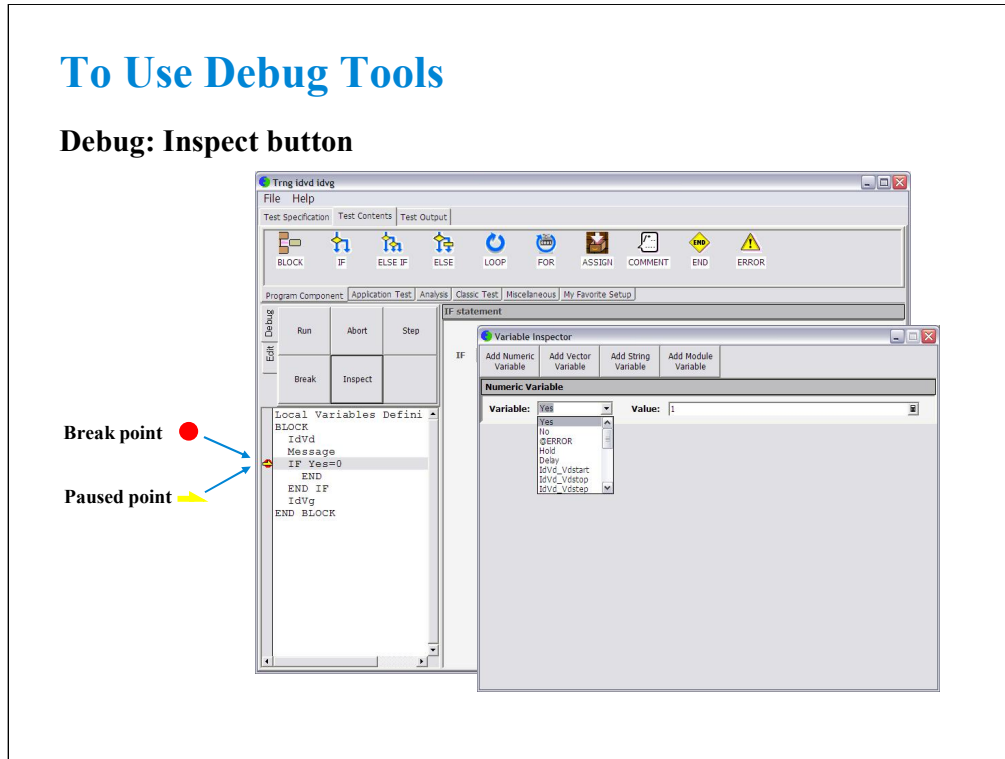

The Variable Inspector is displayed by clicking the Inspect button after the program is paused, and is used to monitor or change the value of the device parameters, test parameters, analysis parameters, local variables, or system variables. For the vector variables, only data monitor is available. The Variable Inspector provides the following buttons to add the variable monitor area.

- Add Numeric Variable
- Add Vector Variable
- Add String Variable
- Add Module Variable

The following functions are available for the menu displayed by clicking the banner of the variable monitor area.

- Up: This button shifts the variable monitor area upward.
- Down: This button shifts the variable monitor area downward.
- Remove: This button deletes the variable monitor area.

To Resave and Close Your Test Definition

Close the definition editor, and overwrite your test definition

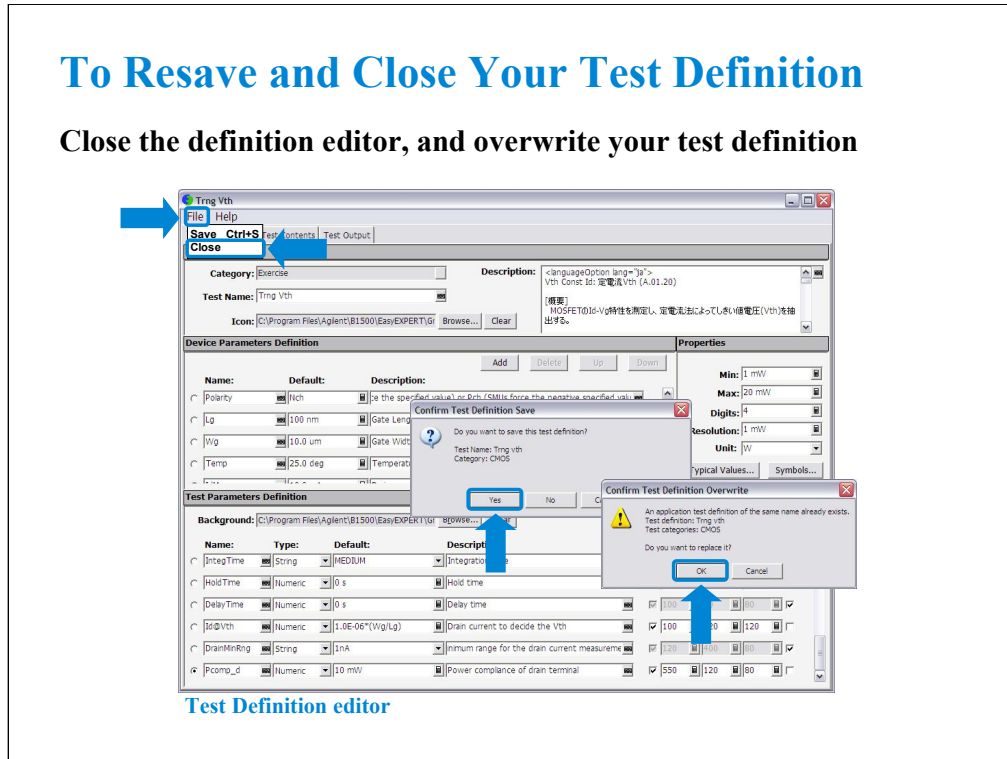

After you create your test definition, save the definition and close the Test Definition editor.

Click File > Close. Confirm Test Definition Save dialog box is opened. Click Yes to save your test definition and continue the close operation. The Confirm Test Definition Overwrite dialog box is opened. Click OK to overwrite your test definition.

To Export/Import Test Definition

Click Library>Export Test Definition or Import Test Definition

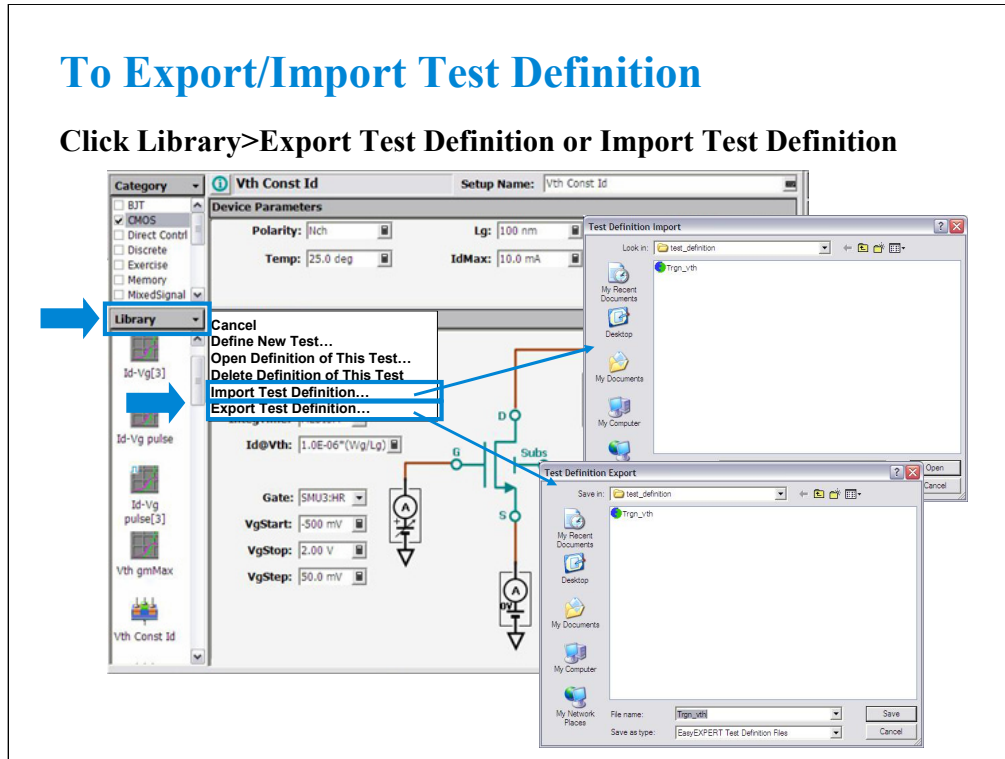

The test definition can be exported as the EasyEXPERT test definition file format or XML file format. And the file can be imported to the EasyEXPERT later.

To Use Built-in Functions

Absolute value:	abs(A)
Averaging:	avg(A), mavg(A,B)
Data conversion:	string(A), value(A)
Difference:	delta(A)
Differentiation, integration:	diff(A,B), integ(A,B)
Exponent, logarithm:	exp(A), lgt(A), log(A)
Maximum, minimum:	max(A), min(A)
Reading data :	getNumericData(A), getVectorData(A)
Square root:	sqrt(A)
Trigonometric function:	acos(A), asin(A) , atan(A), atan2(A,B), cos(A), sin(A), tan(A)

The EasyEXPERT software provides the built-in functions to calculate the display data and parameter or to get the test result data. The built-in functions can be used in the user function and analysis function of the test setup, and in the test execution flow of the test contents.

The following functions are also available.

at(A,B), at(A,B,C), ceil(A), cond(A,B,C,D), dim1Size(A), dim2Size(A), floor(A), index(A,B), isValid(A), setDeviceId(A), storeAt(A,B,C,D), substring(A,B,C), swmToModule(A)

For details of the functions, see User's Guide or online help.

To Use Built-in Functions

User function setup example

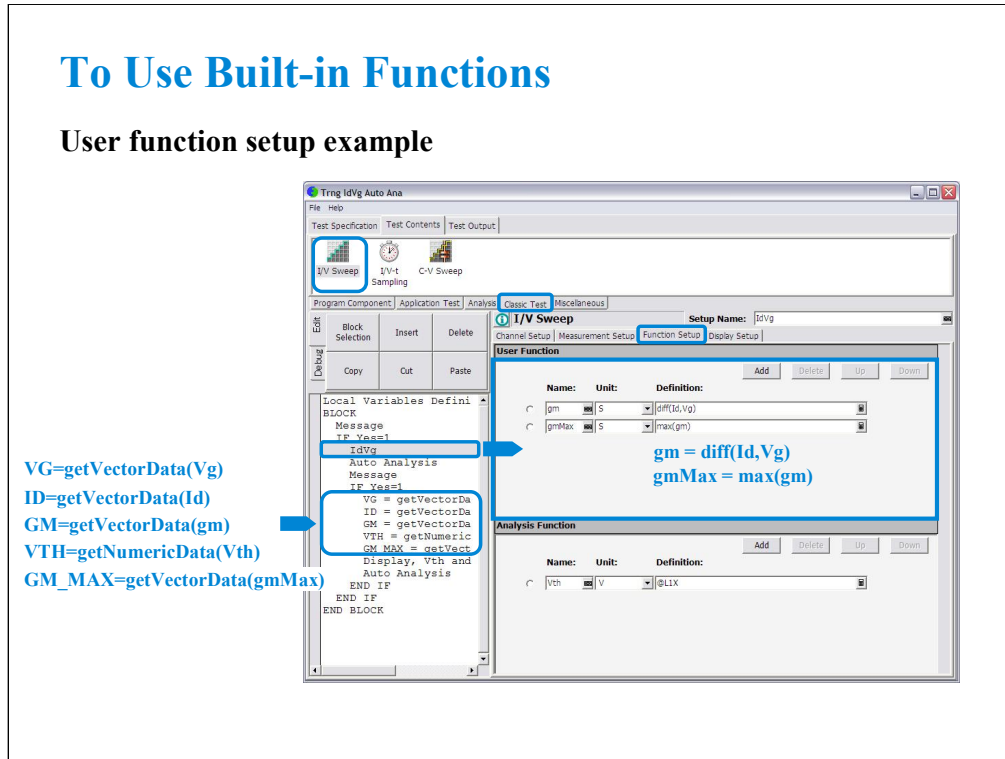

This is an user function setup example. This example uses the diff function to calculate gm values and the max function to get the maximum gm value.

Also, the getVectorData and getNumericData functions are used in the test execution flow to get the test result data.

To Use Read Out Functions

Marker index value:	@MI
X coordinate value:	@MX, @CX
Y coordinate value:	@MY, @MYn, @CY, @CYn
Regression line parameter:	@L1CO, @L2CO
Line slope:	@L1G, @L1Gn, @L2G, @L2Gn
Line X intercept:	@L1X, @L2X
Line Y intercept:	@L1Y, @L1Yn, @L2Y, @L2Yn
Intersection of lines:	@IX, @IY, @IYn

n: integer. 1 to 8.

The EasyEXPERT software provides the read out functions to read the marker position, cursor position, line slope, line intercept, and so on. The read out functions can be used in the analysis function of the test setup.

To Use Read Out Functions

Analysis function setup example

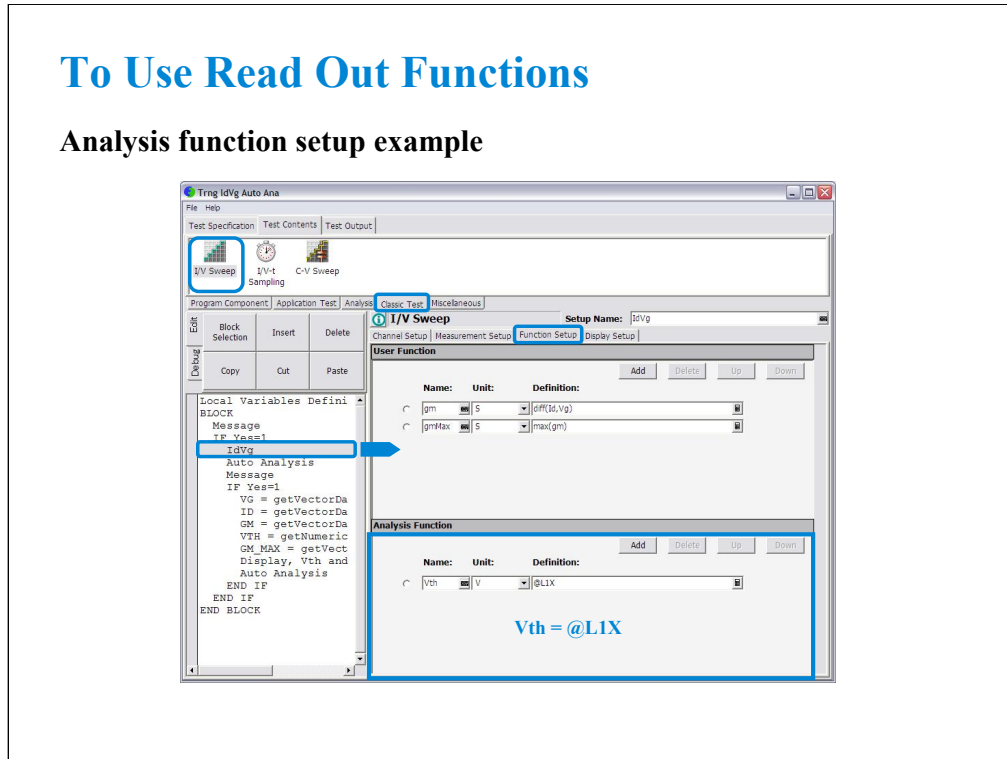

This is an analysis function setup example. This example uses the @LIX function to get the X intercept value of the line 1.

To Add Data Display

Analysis: Display Data Setup

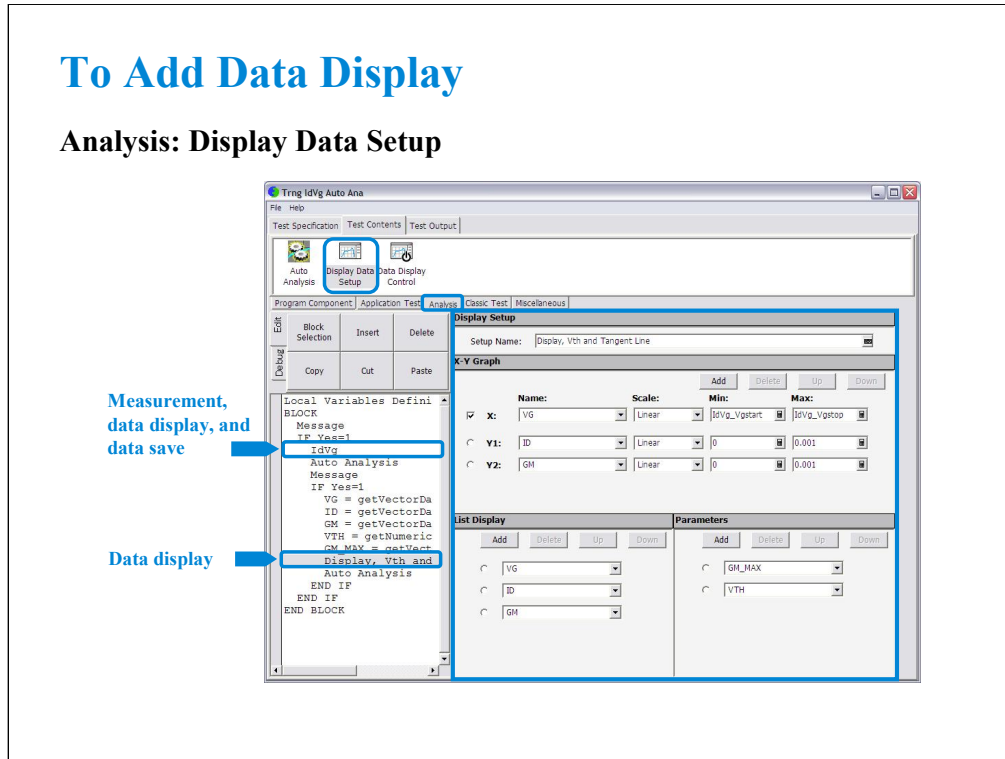

The test setup performs measurement, displays the test result, and stores the test result data to the test record.

In addition to the default test result display, you can make additional data display by using the Display Data Setup statement. The statement provides the user interface as same as the Display Setup of the Classic Test or the Test Output of the test definition. The above example displays the ID-VG/GM-VG curves, GM_MAX and VTH values, and tangent line by using the extra Data Display and Auto Analysis function. See next slide.

Note:

This additional display data cannot be saved to the data record. However only the last display data can be saved if the Test Output has not been set.

To Add Data Display

Additional data display example

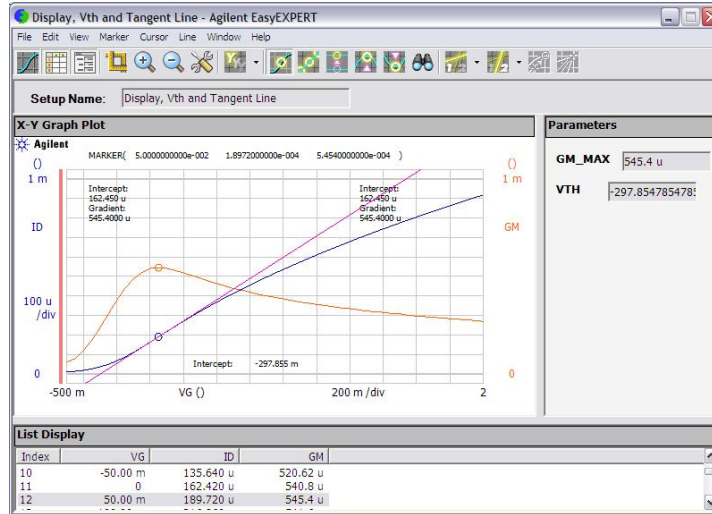

This is a test result example displayed on the Data Display window.
 The auto analysis setup for this example is shown in the next page.

To Use Auto Analysis Function

Analysis: Auto Analysis

- Line 1
- Line 2
- Marker

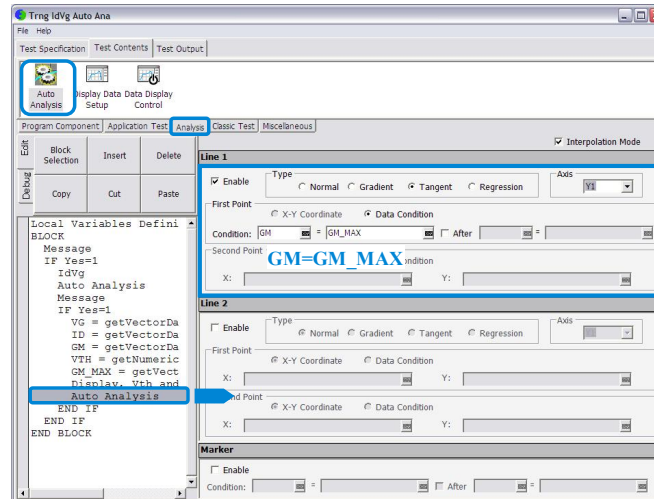

The Auto Analysis statement is used to apply the automatic analysis function to the last test result before this statement. When the test finishes, the function automatically draws lines, a marker, or both on the X-Y Graph of the Data Display window. This statement provides the same GUI as the Auto Analysis setup in the Classic Test.

You can set up two lines and one marker for the automatic analysis function by using the setup editor.

In the Line 1 and Line 2 areas, you can set up the lines to be drawn.

In the Marker area, you can set up the marker.

This example draws the tangent line for the Y1 data at the maximum GM point.

To Control Test Result Data Outputs

Analysis: Data Display Control



Data Display: OFF/ON

Miscellaneous: Data Store Control

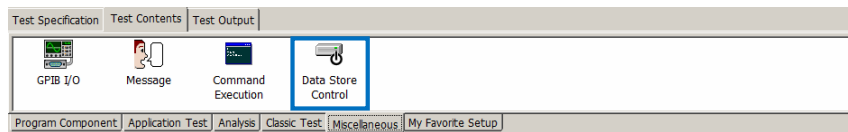

Data Store: OFF/ON

By the default setting, the results of the tests defined in your test definition are displayed on the Data Display window and are stored to the data record.

You can control the data display of the tests by using the Data Display Control statement. Insert the statement, and remove the check from the Enable Data Display box to disable the data display.

You can also control the data storage of the tests by using the Data Store Control statement. Insert the statement, and remove the check from the Enable Creating Test Result Record box to disable the data storage.

The functions cannot control the following data output. They are always enabled.

- Data output by the Test Output of the test definition
- Data output by the last test setup if the Test Output has not been set

To Use Test Setup Internal Variables

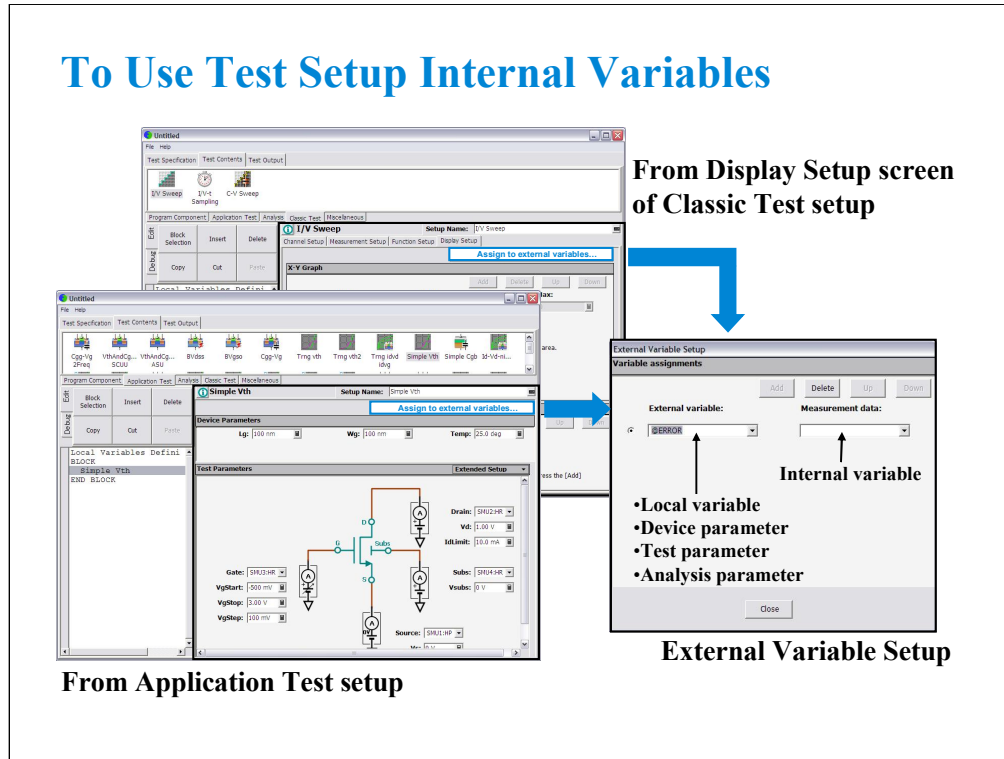

You may want to read the parameters/variables used in Classic Test setup or Application Test setup defined in the Test Contents. Then use the External Variables Setup window used to make a mapping table between the test setup internal variables/parameters and the external variables (local variables, device parameters, test parameters, or analysis parameters).

To open the External Variable Setup window from a classic test setup:

- Specify the classic test.
- Click the Display Setup tab.
- Click the Assign to external variables... button.

To open the External Variable Setup window from an application test setup:

- Specify the application test.
- Click the Assign to external variables... button.

Note: Application test internal parameter/variable to be connected to an external variable must be the analysis parameter in its test definition. For the analysis parameter, see “To Define Test Output” in Module 6.

To Use Test Setup Internal Variables Setup example

Assign to external variables...



External variable:	Measurement data:
VTH	Vth
VG	Vg
GM	gm
GM_MAX	gmMax
ID	Id

This example makes the mapping table between the test setup internal parameters and the analysis parameters.

- Define VTH, GM_MAX, VG, ID, and GM as the analysis parameters.
- Set these analysis parameters to the display parameters.
- Open the External Variable Setup dialog box.
- Assign VTH to the internal parameter Vth.
- Assign VG to the internal parameter Vg.
- Assign GM to the internal parameter gm.
- Assign GM_MAX to the internal parameter gmMax.
- Assign ID to the internal parameter Id.

For the example definition, open the Trng idvd idvg2 definition stored in the %data folder on the Manual CD. The Manual CD stores the example test setup and definition data used in this manual.

To Use Test Setup Internal Variables Result example

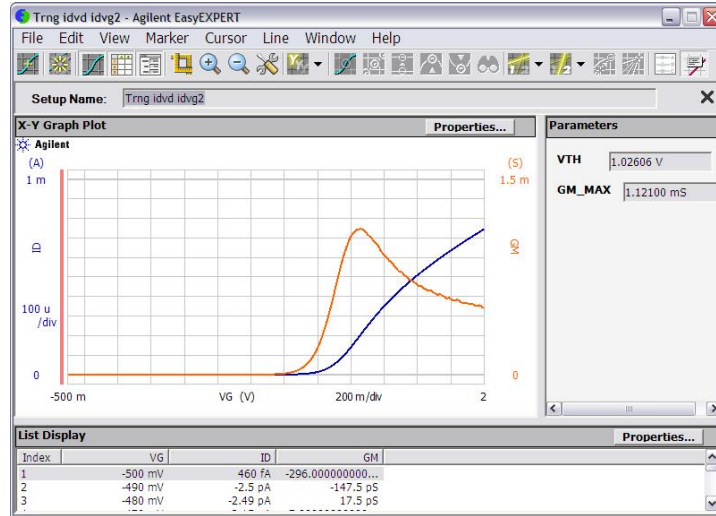

This is a result example of the test output setup shown in the previous pages.

To Use Test Setup Internal Variables Using built-in functions

Local Variables Definition

BLOCK

IdVg ← Test setup

VG = getVectorData("Vg")

ID = getVectorData("Id")

GM = getVectorData("gm")

GM_MAX = getVectorData("gmMax")

VTH = getNumericData("Vth")

IdVd ← Test setup

END BLOCK

Display parameters of the last Data Display window

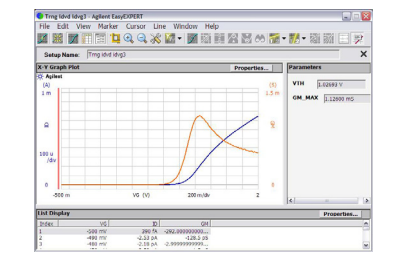

**Vg, Id, gm, gmMax, and Vth
must be the display
parameters of IdVg.**

This example shows another way to read the value of the internal variables (Vg, Id, gm, gmMax, and Vth). In this example, you do not use the mapping table but use the getVectorData and getNumericData built-in functions. The functions can be used to read the value of parameters displayed on the last data display.

To read the value:

- Define VG, ID, GM, GM_MAX, and VTH as the analysis parameters.
- Set these analysis parameters to the display parameters.
- Insert the ASSIGN statements to add the formula shown above.

Note: Application test internal parameter/variable to be connected to an external variable must be the analysis parameter in its test definition. For the analysis parameter, see "To Define Test Output" in Module 6.

To Use Test Setup Internal Variables Using built-in functions, setup example

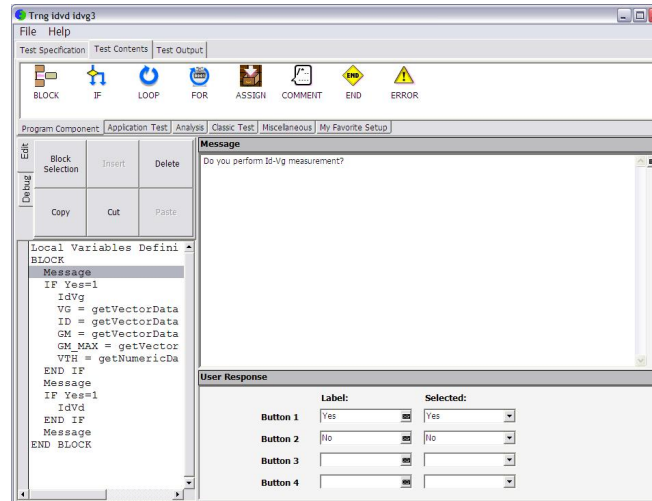

This example sets the following test flow:

Local Variables Definition ! Defiles Yes variable

BLOCK

Message ! Do you perform Id-Vg measurement?

IF Yes=1

IdVg ! Classic test setup for Id-Vg measurement

VG=getVectorData("Vg")

ID=getVectorData("Id")

GM=getVectorData("gm")

GM_MAX=getVectorData("gmMax")

VTH=getNumericData("Vth")

END IF

Message ! Do you perform Id-Vd measurement?

IF Yes=1

IdVd ! Classic test setup for Id-Vd measurement

END IF

Message ! Click OK to display VTH and GM_MAX values and end the test

END BLOCK

For the example definition, open the Trng idvd idvg3 definition stored in the %data folder on the Manual CD. The Manual CD stores the example test setup and definition data used in this manual.

To Use Test Setup Internal Variables Using built-in functions, result example

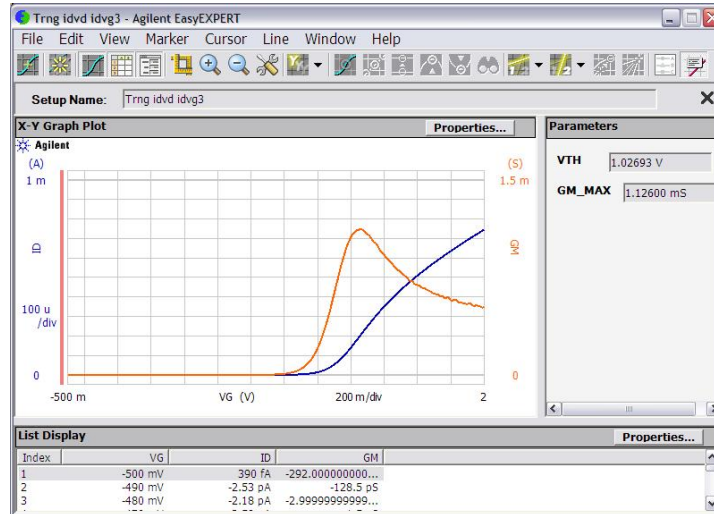

This is a result example of the test output setup shown in the previous pages.

Class Exercise

To use Auto Analysis twice

You will:

- Make two kinds of MOS threshold voltage (V_{th}) measurements
- Observe how the user functions and analysis functions are used in the analysis
- Observe how auto analysis works twice

To Get Started:

- Use the standard MOS device and pin connections
- Get the V_{th} gmMax setup
- Open test definition editor
- Modify the definition for V_{th} measurement by using the constant current method.

In this exercise you will observe how auto analysis works. You will understand each setup screen required to implement an auto analysis process.

To Modify Test Definition Opening Vth gmMax test definition

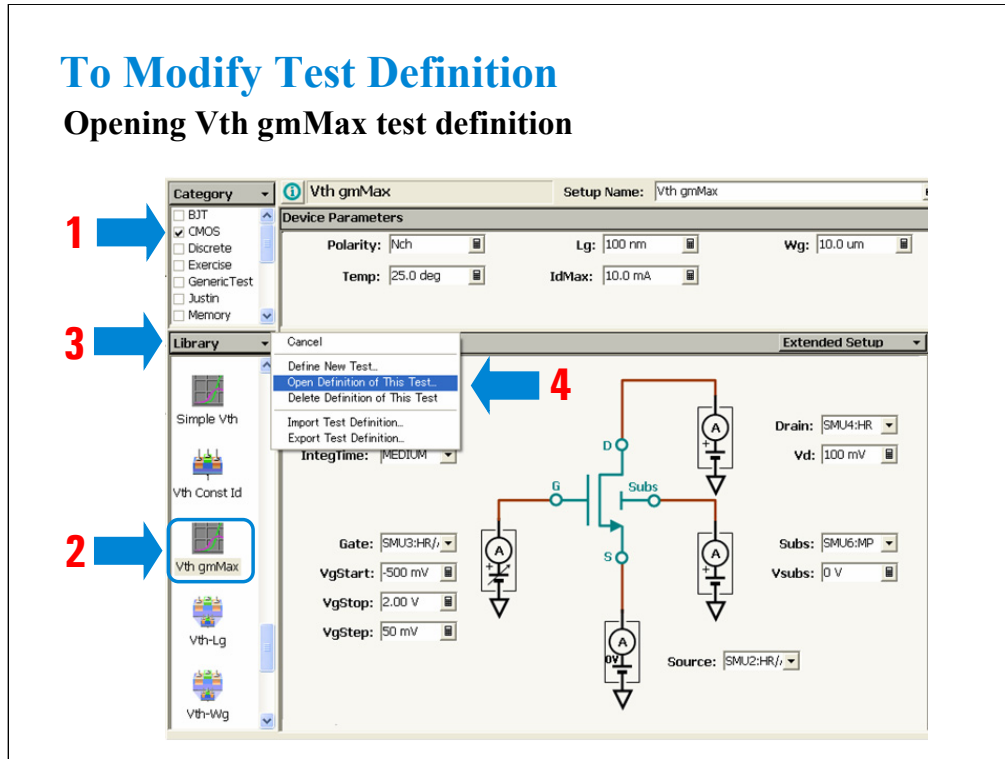

1. Select the CMOS category.
 2. Open the Vth gmMax test definition.
 3. Click the Library button.
 4. Select the Open Definition of This Test... menu.
- The test definition editor is opened with the Vth gmMax test definition.

To Modify Test Definition

Setting properties of numeric variable

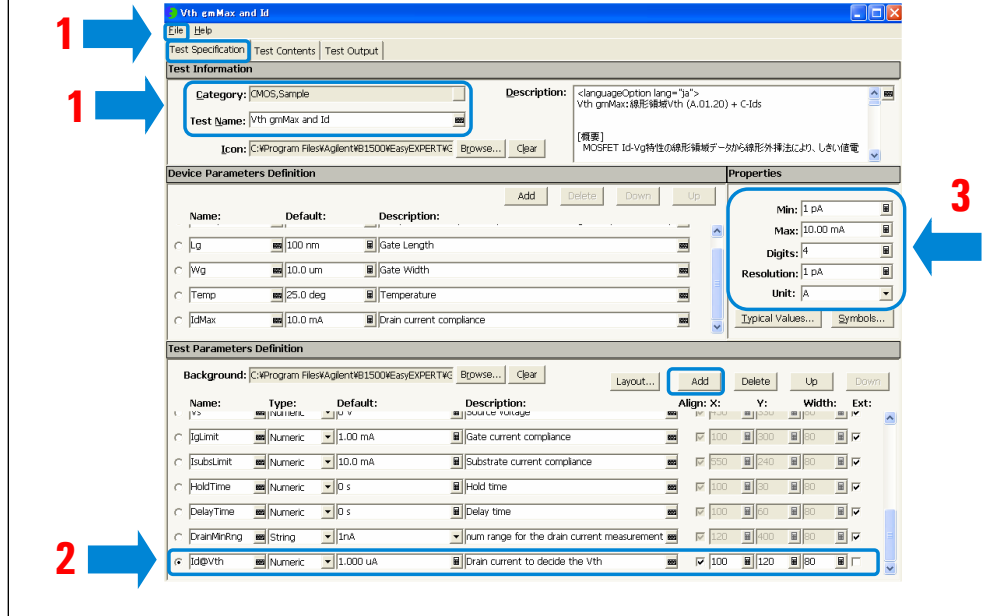

1. Save the test setup as a new one. For example, save it as Vth gmMax and Id of the Exercise category.

Click Add button to display the entry fields for the parameter.

2. Select the Id@Vth variable and the type of Numeric.

3. Set properties of the Id@Vth variable.

To Modify Test Definition

Analysis function setup

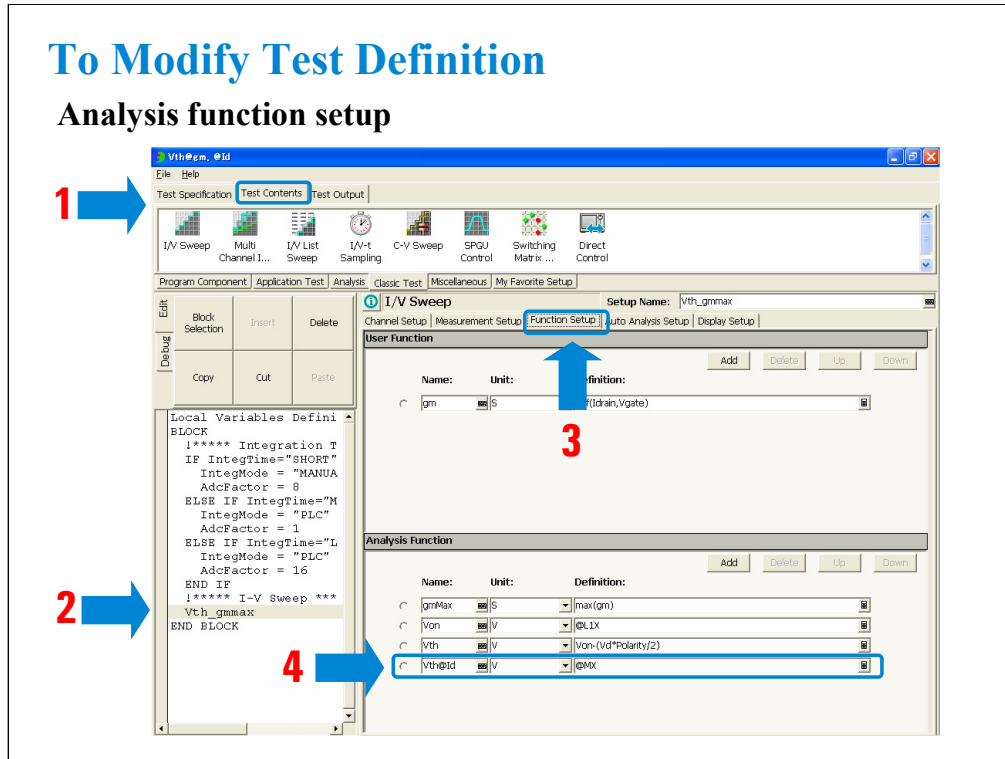

1. Display the Test Contents screen.
2. Highlight the Vth_gmmax line.
3. Click the function Setup tab.
4. Add the Analysis function. Set the following parameters.

<Name>	<unit>	<Definition>
Vth@Id	V	@MX

This is an analysis function setup example. This example uses the @MX function to get the X coordinate value.

Auto Analysis Setup

Auto Analysis Setup

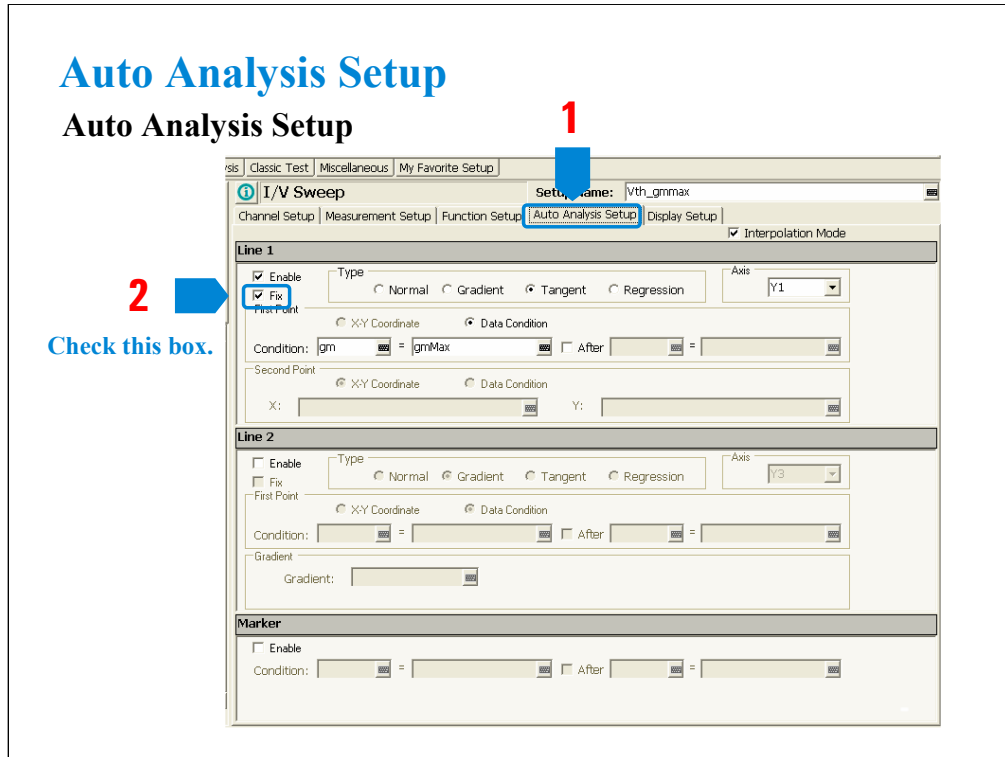

1. Click the Auto Analysis Setup tab to display the Auto Analysis setup screen.
2. Check the box to fix the Line 1. If the box is not checked, the line will be moved when the 2nd Auto Analysis is done.

The 1st Auto Analysis is set in this slide.

To Set Display Setup

Display Setup

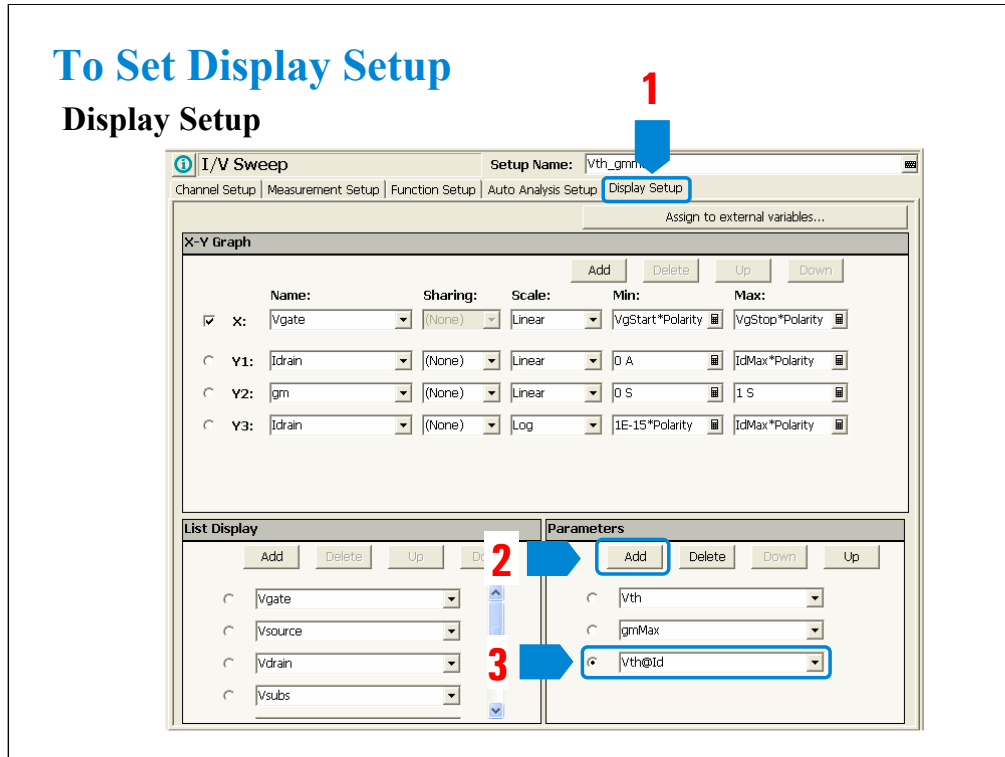

1. Click the Display Setup tab.
2. Click Add button to display the entry fields for the parameter.
3. Select Vth@Id to display.

Auto Analysis Setup

The 2nd Auto Analysis Setup

1 Test Contents

2 Analysis

3 Auto Analysis

4 Insert

5 Interpolation Mode

6 Enable

Condition: $I_{drain} = I_d @ V_{th} * Polarity$

```

Local Variables Defini
BLOCK
I***** Integration T
IF IntegTime="SHORT"
  IntegMode = "MANUA
  AdcFactor = 8
ELSE IF IntegTime="M
  IntegMode = "PLC"
  AdcFactor = 1
ELSE IF IntegTime="L
  IntegMode = "PLC"
  AdcFactor = 16
END IF
I***** I-V Sweep ***
Vth_gmmax
Auto Analysis
END BLOCK
  
```

1. Display the Test Contents screen.
2. Click the Analysis Setup tab.
3. Highlight the Auto Analysis icon.
4. Hit Insert button.
5. Check the box of Interpolation Mode.
6. Check the box of Enable. Then enter $I_{drain} = I_d @ V_{th} * Polarity$ to find the constant current V_{th} .

The 2nd Auto Analysis is set in this slide.

To Use Auto Analysis Twice Result example

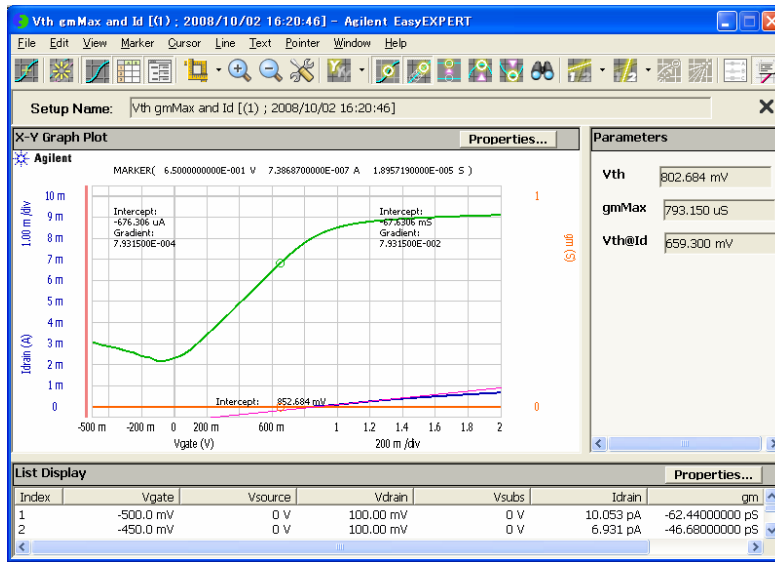

This is a result example of using two times Auto Analysis shown in the previous pages. Vth, gmMax and Vth@Id are automatically calculated.

Class Exercise

To Use Vector Data.

- 1. Open the Cgg-Vg test definition.**
- 2. Modify it for the multiple frequency test using a vector variable.**
- 3. Use the debug tools.**
- 4. Save the definition as a new one (ex. Trng Cgg-Vg).**
- 5. Perform the test.**
- 6. Export the new definition, and import it.**

See the following pages which show an example to use a vector data. The Cgg-Vg test definition is used as the reference of this example. The FREQ variable in this test definition will be changed from the numeric type to the vector type.

To Modify Test Definition

Opening Cgg-Vg test definition

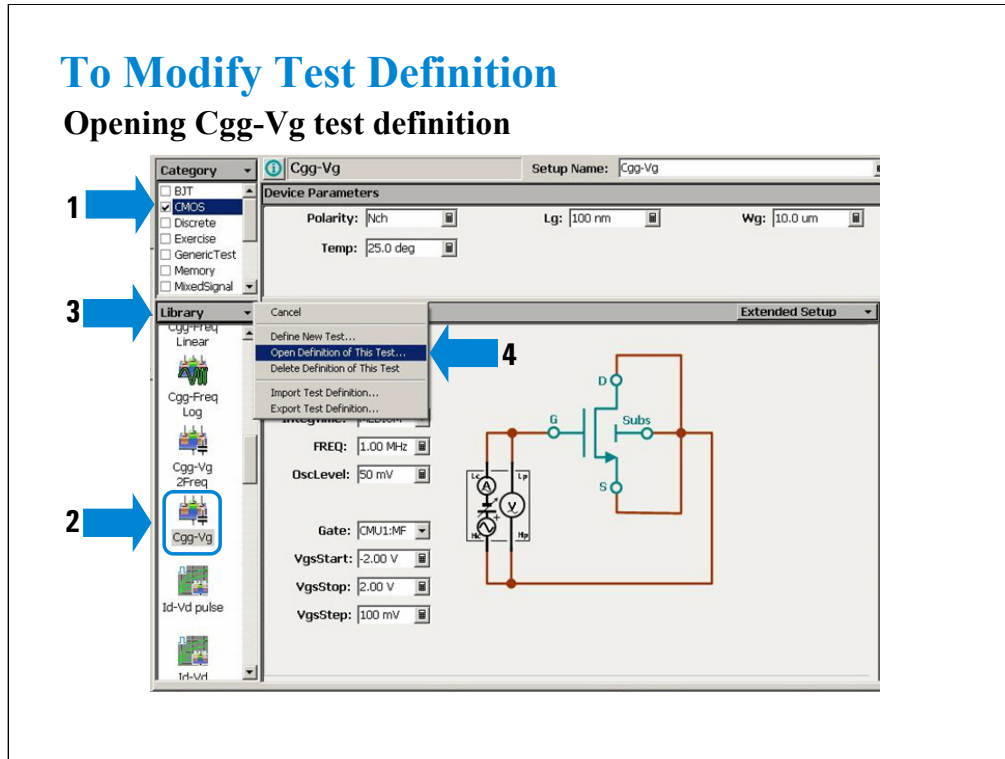

1. Select the CMOS category.
 2. Open the Cgg-Vg test definition.
 3. Click the Library button.
 4. Select the Open Definition of This Test... menu.
- The test definition editor is opened with the Cgg-Vg test definition.

To Modify Test Definition

Setting properties of vector variable

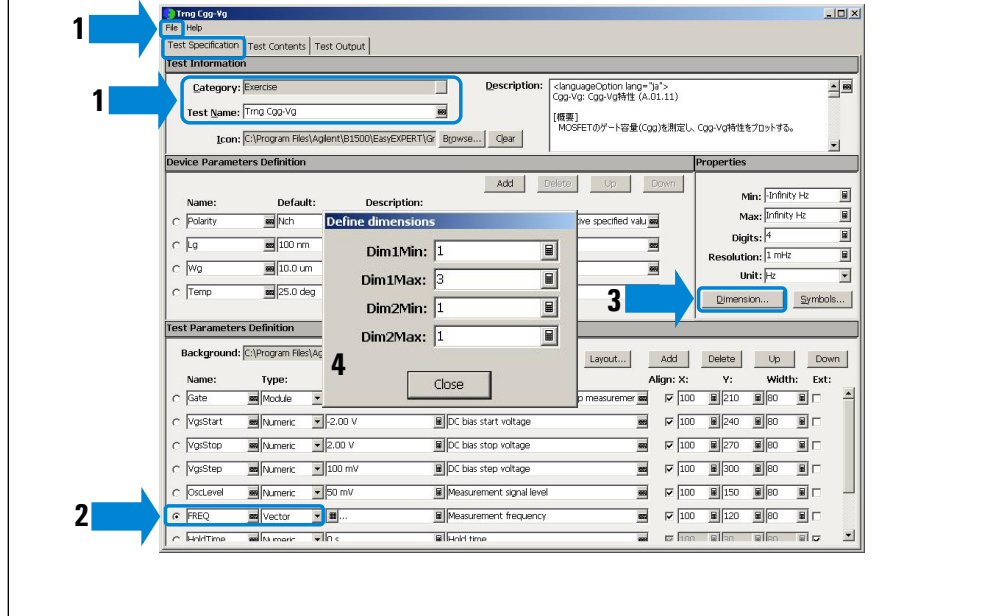

1. Save the test setup as a new one. For example, save it as Trng Cgg-Vg of the Exercise category.
 2. Select the FREQ variable and change the type from Numeric to Vector.
 3. Click the Dimension... button. The Define dimensions dialog box appears.
 4. Set the dimension of the FREQ variable.
- The example in this slide sets the one dimension and three elements vector variable.

To Modify Test Definition

Setting vector data

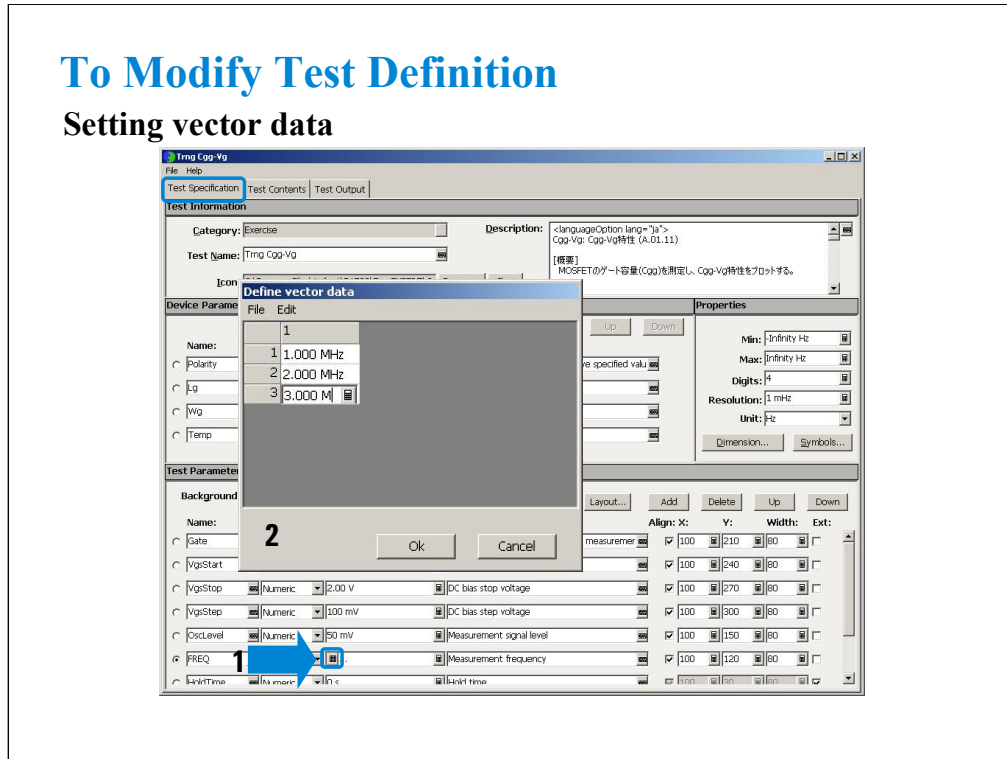

1. Click the Grid button of the FREQ variable. The Define vector data dialog box appears.
2. Define the vector values for the FREQ variable.

The example in this slide sets the value 1 MHz, 2 MHz, and 3 MHz to the FREQ three elements vector variable.

To Modify Test Definition

Using the at() function to read vector data

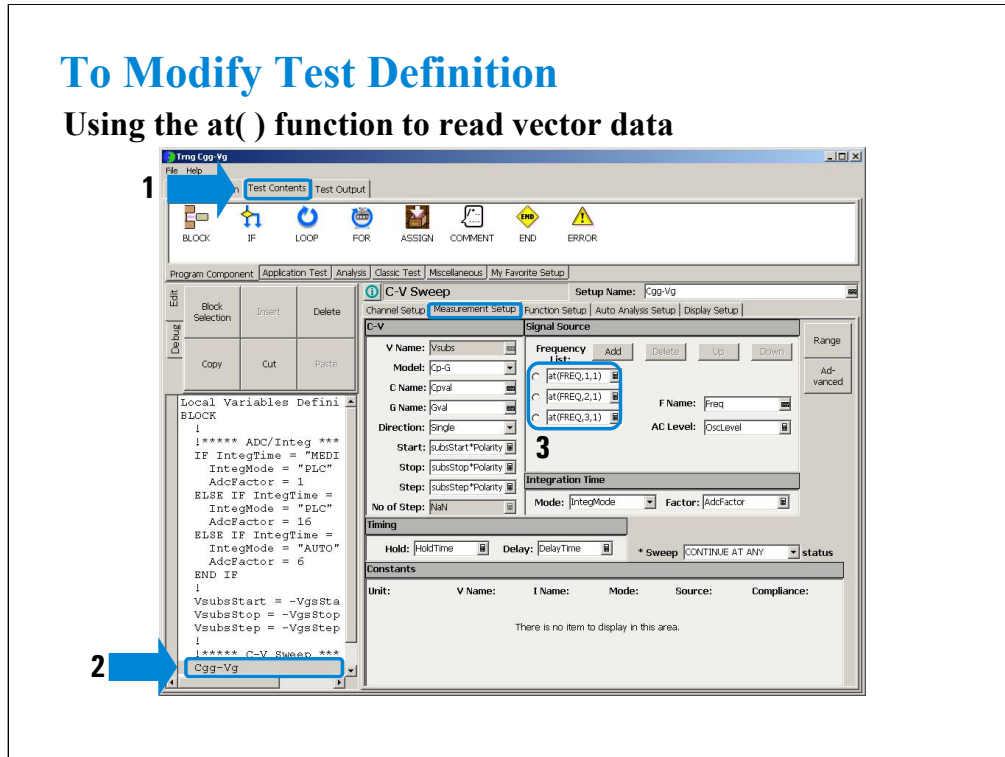

1. Display the Test Contents screen.
2. Highlight the Cgg-Vg line.
3. Click the Measurement Setup tab and set the Frequency List using the at() functions.



6 Creating Your Test Definitions



In This Module

- **What is Test Definition**
- **What is Test Contents**
- **To Open Test Definition Editor**
- **To Define Test Specification**
- **To Define Test Contents**
- **Available Elements**
- **Available Variables**
- **To Define Test Output**

This section explains how to create your test definition. You will perform the above tasks to create the definition.

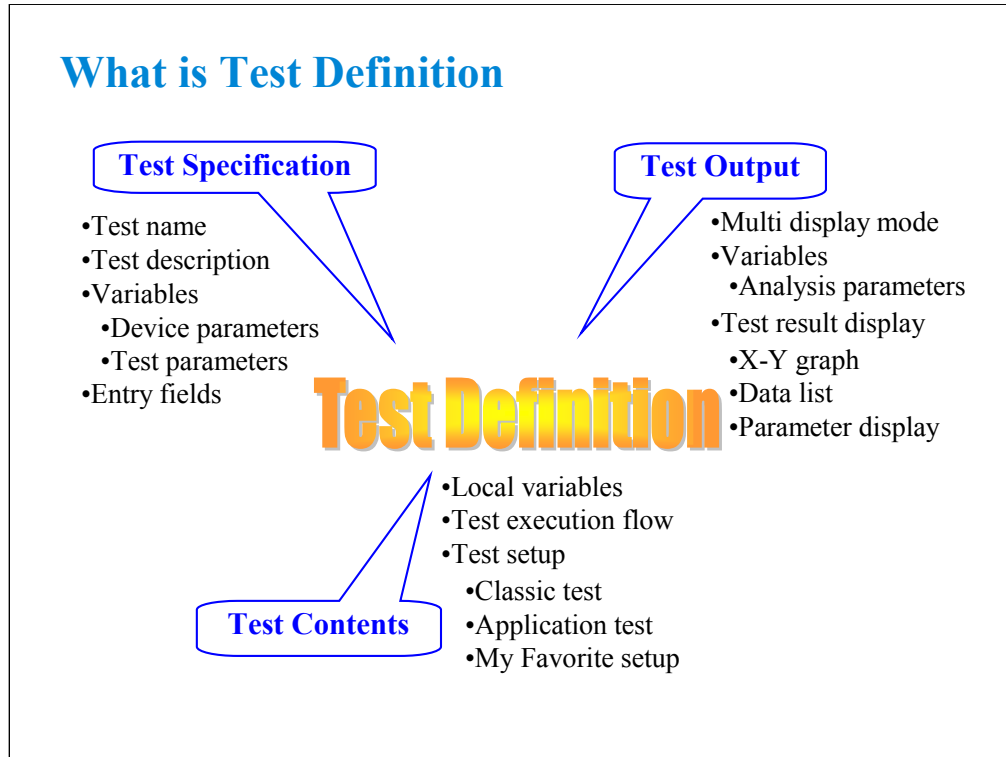

Test definition consists of test specification, test contents, and test output setup. The test specification contains test name, description, device parameters, and test parameters. The parameters will be the variables used to pass the test conditions to the test execution flow or test setup defined in the test contents. Especially for the test parameters, you can specify the position of entry field for each parameter. You can see the entry fields when the main screen displays this application test setup. The test contents are the core of the test definition. You will define the local variables, test execution flow, and test setup. You can define the test setup by selecting application tests, classic tests, or my favorite setup, and entering the test conditions.

The test output setup is optional. If you have the following requirements, declare the analysis parameters and define the display parameters on the Test Output tab screen.

- To send the test data to the subsequent tests
- To make the program branching depends on the test data
- To display/record the calculation result using the test data
- To display/record the test data of this application test
- To change the multi display mode of this application test

Note: You can use the device parameters, test parameters, and analysis parameters in the test execution flow (program flow) of the test contents without declaration of local variables.

Note: If the multi display mode is Disabled, the all test result data will be displayed on the singular Data Display window. If the multi display mode is Enabled, the test result data of the same test setup name will be displayed on the exclusive Data Display window and the test result data of the different test setup name will be displayed on the new Data Display window.

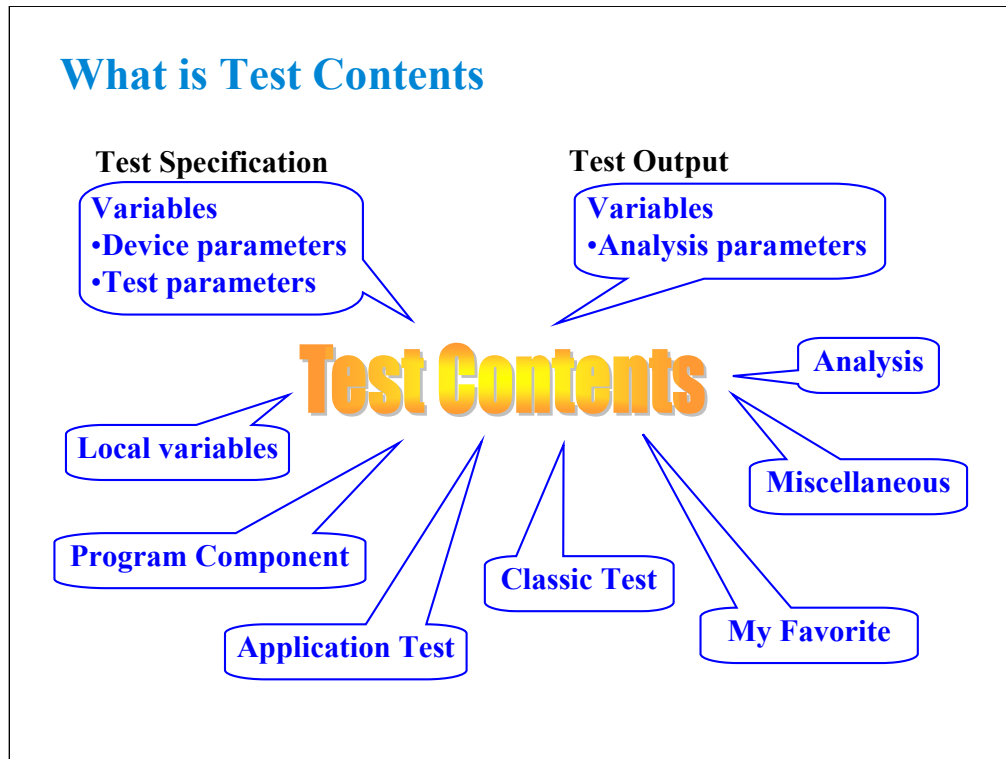

Test contents are the test execution flow (program flow), and is the core of the test definition. In the test contents, the following elements can be defined.

- Local variables
- Program components
- Application tests
- Classic tests
- My Favorite setup
- Analysis components
- Miscellaneous components
- Device parameters defined in the test specification
- Test parameters defined in the test specification
- Analysis parameters defined in the test output

The program is executed from top to bottom in the test execution program list.

To Open Test Definition Editor

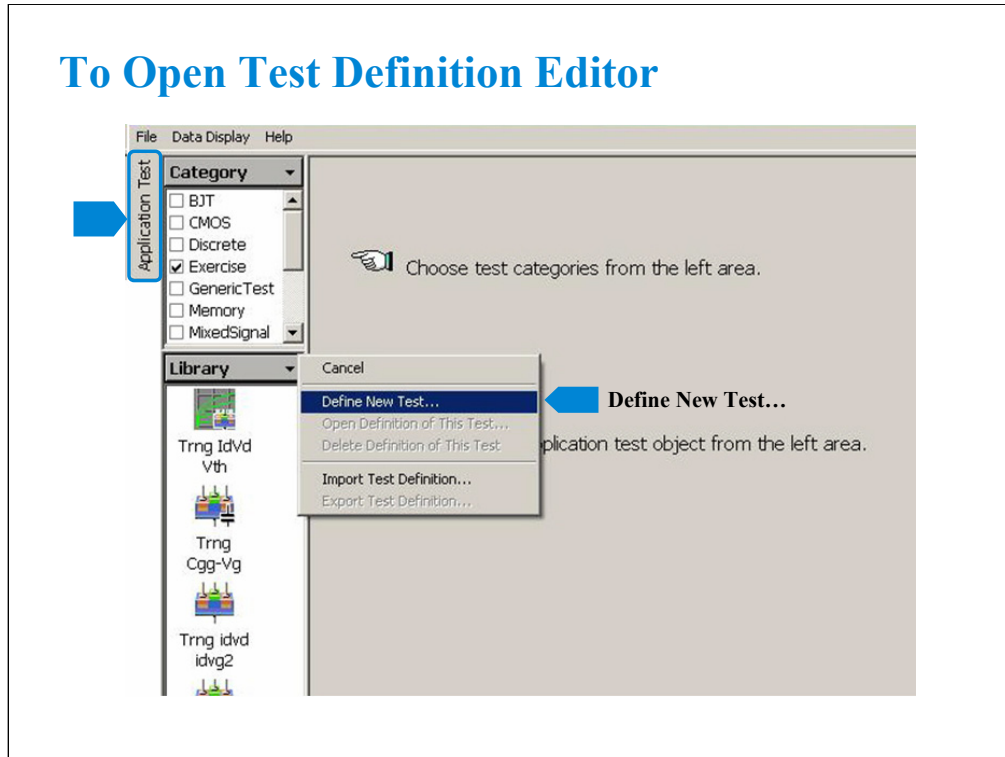

To start test definition, open the test definition editor.

Select the Application Test tab, click the Library button, and select the Define New Test... function. The test definition editor will be opened. See next slide.

To Define Test Specification

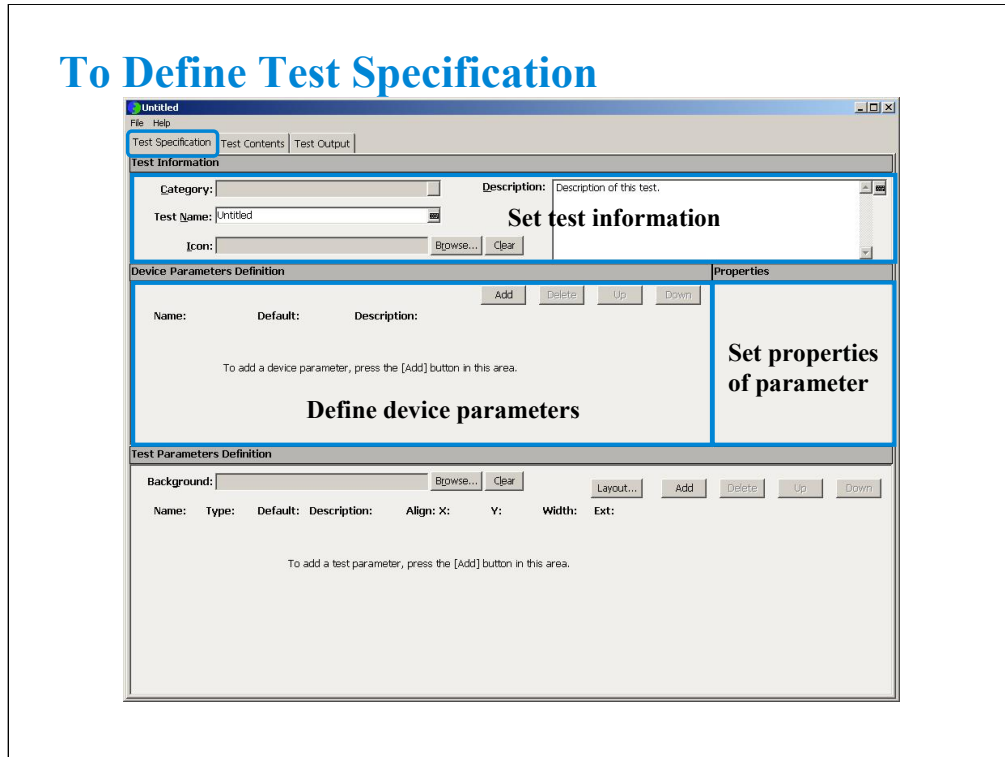

The test definition editor provides three tabs, Test Specification, Test Contents, and Test Output. At first define the test specification. Click the Test Specification tab.

In the Test Information area:

- Click the right button in the Category field to specify the category the new test definition belongs.
- Enter the Test Name.
- Select the Icon that will be displayed on the list area below the Library button of the main screen. It is the image file used to select the test definition. See previous slide.
- Enter the Description of the test.

In the Device Parameters Definition area:

- Click Add button to display the entry fields for the parameter.
- Set the Name, Default value, and Description for the parameter. When you add a parameter, you will see the entry fields at the Properties area. The area shows you the properties (minimum value, maximum value, number of effective digits, resolution, and unit) for the device parameter or the test parameter specified by the radio button put on the left of the parameter name.

For the Typical Values... button and the Symbols... button, see online help or User's Guide.

To Define Test Specification

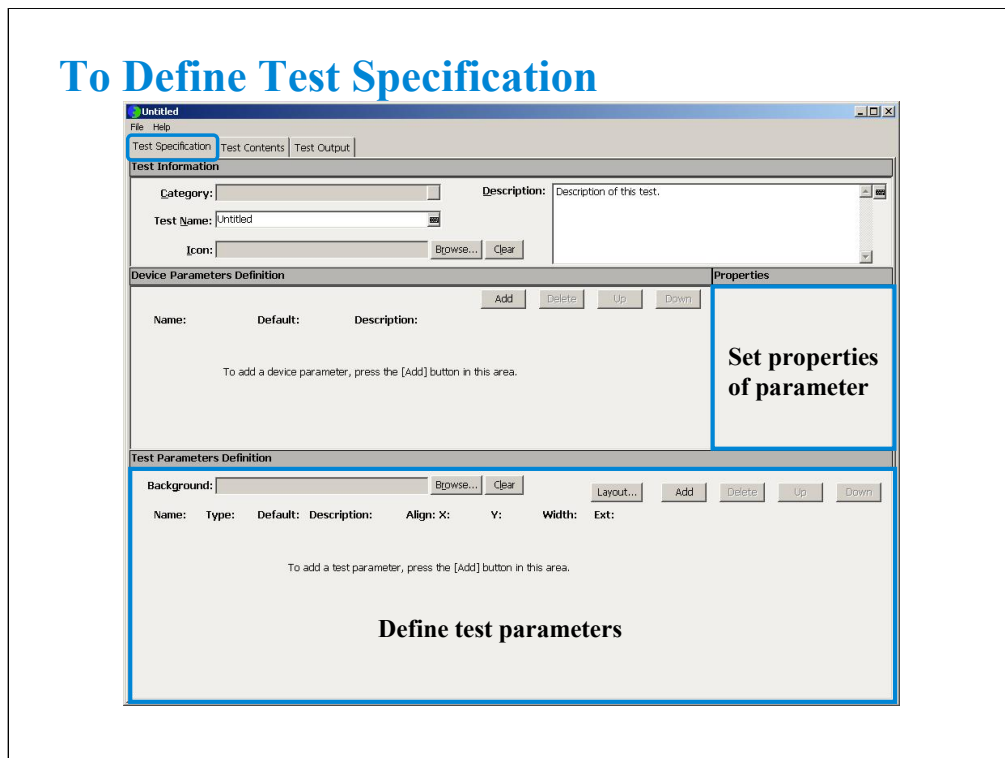

In the Test Parameters Definition area:

- Select the Background that will be displayed on the application test setup area of the main screen. Usually it is the image that shows the device connections.
- Set the Name, data type, Default value, and Description for the parameter. When you add a parameter, you will see the entry fields at the Properties area. The area shows you the properties (minimum value, maximum value, number of effective digits, resolution, and unit) for the device parameter or the test parameter specified by the radio button put on the left of the parameter name.
- Set the X, Y, and Width values to specify the position of entry field displayed on the application test setup area.
- Check the Align box to set the X origin of entry field to the left edge of the entry field. Uncheck this box to set it to the left edge of the parameter name placed left next to the entry field.
- Check the Ext box. The entry field will be put on the Extended Test Parameters dialog box that is displayed by clicking the Extended Setup button on the application test setup area of the main screen.

Setup example

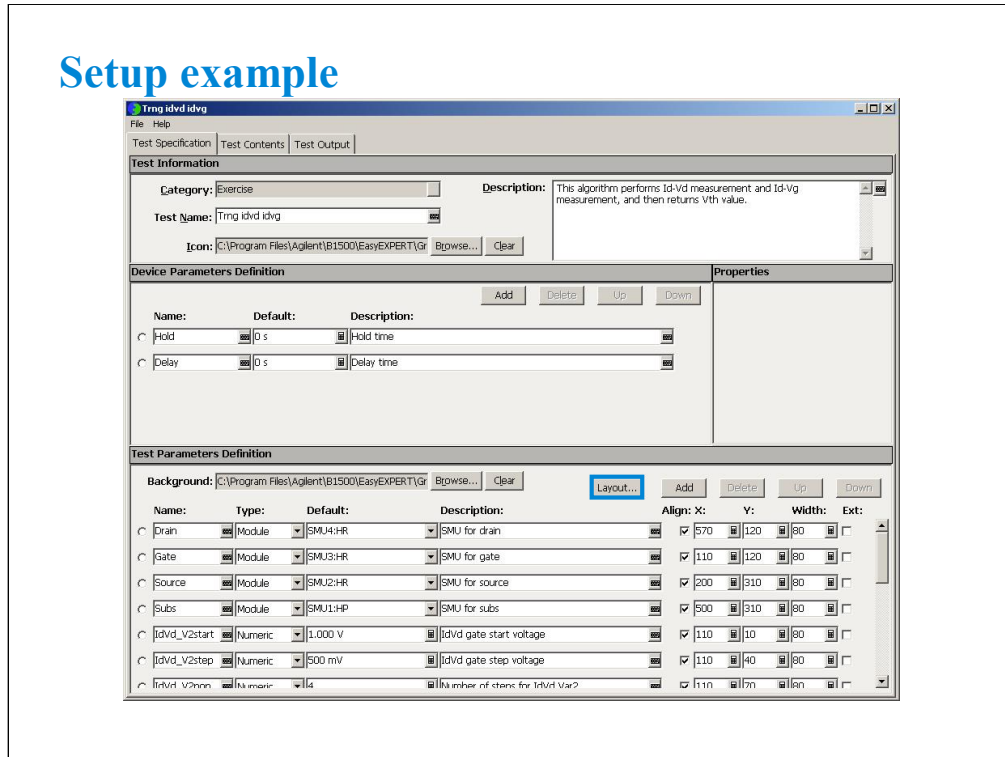

This example sets:

Category: Exercise (This category may be created by the class exercise in Module 5)

Test Name: Trng idvd idvg

Icon: MOSFET.bmp

Device parameters:

Hold and Delay

Background: Vth_Const_Id.PNG

Test parameters:

Drain, Gate, Source, Subs, Idcomp, Igcomp

IdVd_V1start, IdVd_V1step, IdVd_V1stop, IdVd_V2start, IdVd_V2step, IdVd_V2nop

IdVg_V1start, IdVg_V1stop, IdVg_V1step, IdVg_Vdrain

Vsource, Vsubs

Entry field properties: 80 (width) x 30 (distance in vertical direction)

Press the Layout... button to open the Define Layout dialog box.

Setup example - Layout

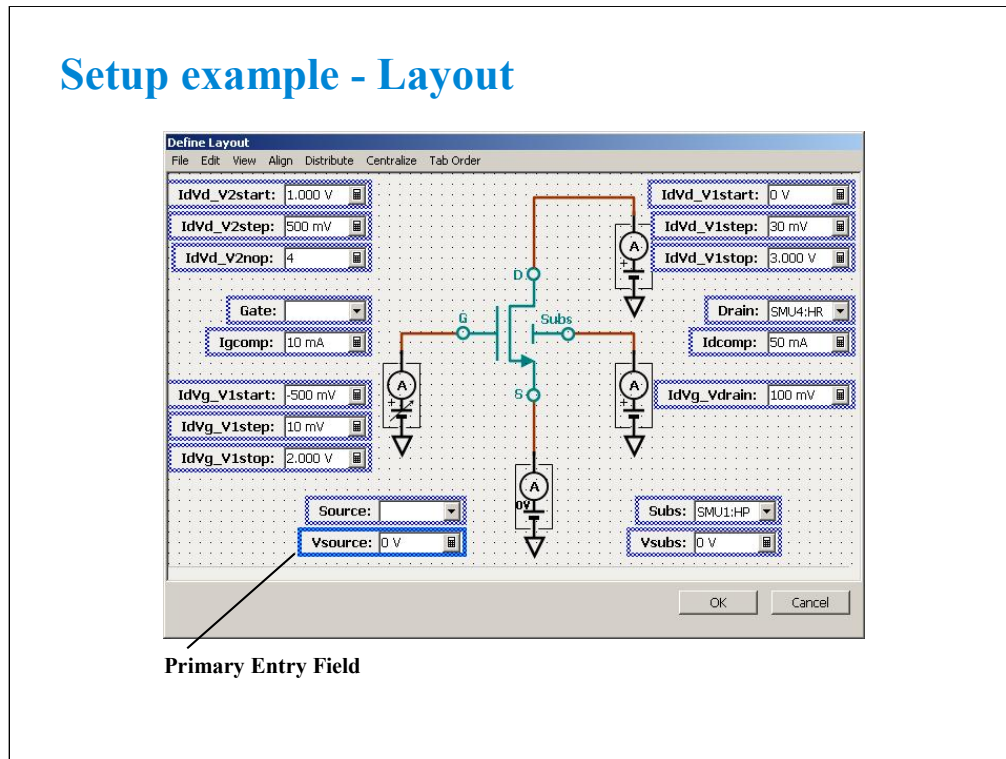

The Define Layout dialog box is used to define the layout of the test parameter entry fields displayed on the application test setup screen.

The following methods are available for selecting the entry fields.

- Click on the entry field. Multiple entry fields can be selected by clicking on the entry field while holding down the Ctrl key on the keyboard.
- Drag the mouse to draw a rectangle around multiple entry fields.
- Select Select All from the EDIT menu to select all entry fields.

The selected entry fields are outlined by the blue rectangles. The primary entry field, which is the base for layout operations, is surrounded by a highlighted blue rectangle. Only one primary entry field can be selected. To change the primary entry field, click on a selected entry field. The entry field is always that was most recently clicked will be the primary entry field.

The following methods are available for releasing (unselecting) the selected entry fields.

- Click the selected entry field while holding down the Shift key on the keyboard.
- Click outside of the selected entry fields to release all selected entry fields.

The following methods are available for defining the layout of the selected entry fields.

- Drag & drop with the mouse to move the selected entry field(s).
- Change the X/Y values in the property window to move the selected entry field(s).
- Press the arrow keys on the keyboard to move the selected entry field(s).
- Use the functions in the Align menu to align the selected entry field(s) to the primary entry field.
- Use the functions in the Distribute menu to evenly distribute the selected entry fields horizontally or vertically.
- Use the functions in the Centralize menu to move the horizontal or vertical center of all selected entry fields to the horizontal or vertical center of the entry field area.

For more information, see online help or User's Guide.

Result example

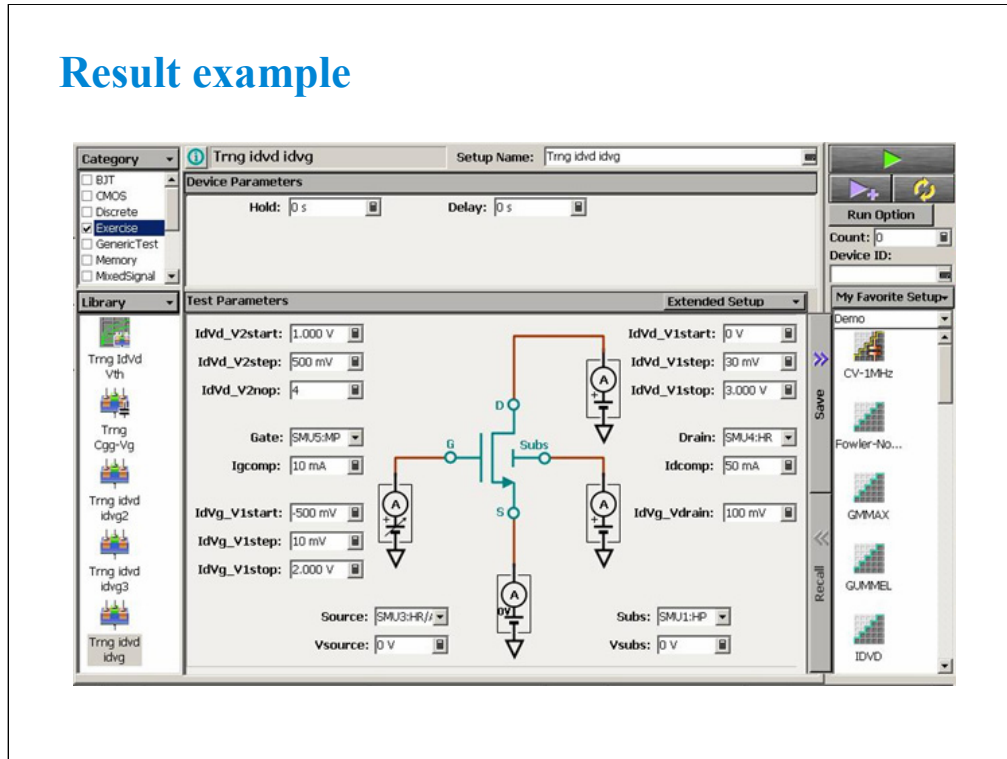

This is a result example of the test specification setup shown in the previous pages.

To Define Test Contents

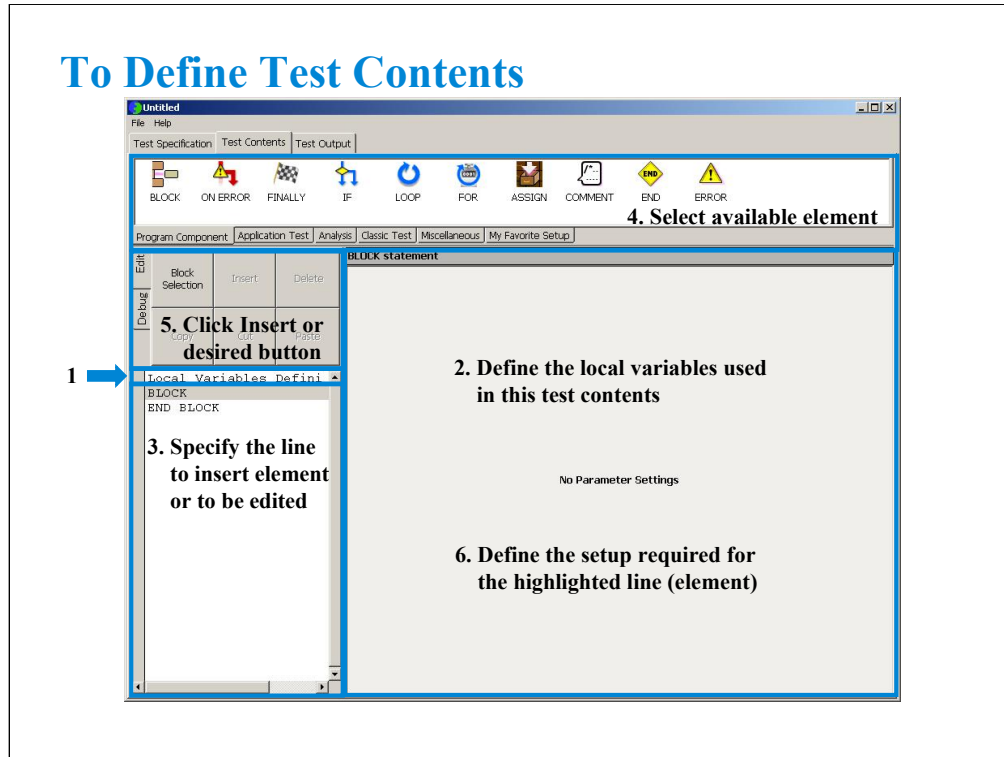

Starting to define the test contents:

1. Highlight the Local Variables Definition line.
2. Define the local variables used in this test contents (test execution flow).
3. Highlight the line that an element has to be inserted.
4. Highlight an element of Program Component, Application Test, Analysis, Classic Test, Miscellaneous, or My Favorite Setup tab menu.
5. Click the Insert button of the Edit tab menu. The element will be inserted between the highlighted line and the next line.
6. Define the required setup.

To edit the test contents:

1. Optional. Highlight the Local Variables Definition line.
2. Optional. Define the local variables used in this test contents (test execution flow).
3. Highlight the line to be edited.
4. Highlight an additional element if you need.
5. Click the desired button if you need.
6. Define the required setup if you need.

Repeat this to create the test contents (test execution flow).

Available elements

	Program Component
Category 	Application Test
	Analysis
	Classic Test
	Miscellaneous
Preset Group: <input type="text" value="cmg"/>	My Favorite

Available elements are shown above. The Program Component provides the typical program statements such as IF, LOOP, FOR, and so on. They are used to control the test execution flow. The Application Test, Classic Test, and My Favorite are used to define the test setup/test condition. The Analysis provides the elements used to control auto analysis function and data display. And the Miscellaneous provides other useful elements. For details of elements, see online help or user's guide.

Available variables

Test Contents
•Local variables

Test Specification
•Device parameters
•Test parameters

Test Output
•Analysis parameters

Do not set the same name for variables and parameters. The name must be unique.

Assign to external variables...

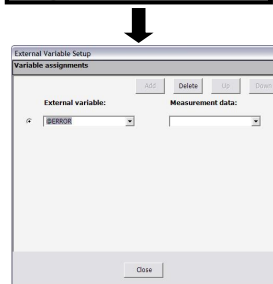

You can connect the variables in test setup with

- Local variables
- Device parameters
- Test parameters
- Analysis parameters

In the test execution flow (program flow), you can use the following variables.

- Variables defined by the Local Variables Definition component
- Device parameters defined in the Test Specification
- Test parameters defined in the Test Specification
- Analysis parameters defined in the Test Output

You may want to read the parameters/variables used in Classic Test setup or Application Test setup defined in the Test Contents. Then use the External Variables Setup dialog box or built-in functions. They can connect the test setup internal variables/parameters to the external variables listed above. For the example variable connections, see “To Use Test Setup Internal Variables” in Module 5.

Note: Application test internal parameter/variable to be connected to an external variable must be the analysis parameter in its test definition.

Defining local variables

Local Variables Definition

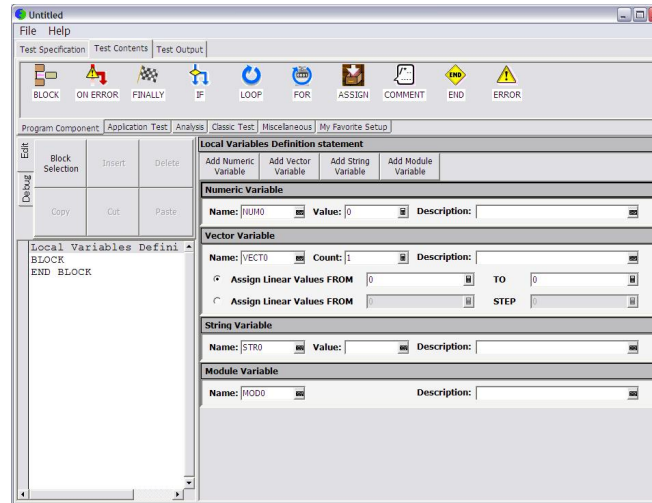

Add Numeric Variable button displays the Numeric Variable area that provides the following fields.

- Name: Numeric variable name
- Value: Initial value of the variable
- Description: Additional information for the variable

Add Vector Variable button displays the Vector Variable area that provides the following fields.

- Name: Vector variable name. Two dimensional array.
- Count: Number of elements, or array size
- Description: Additional information for the variable

This area also provides the following radio button used to specify how to set the initial value of the array data automatically.

- Assign Linear Values FROM [*value of first element*] TO [*value of last element*]

If $Count > 1$, this sets $first\ value + (N-1) \times (last\ value - first\ value) / (Count - 1)$ to the N -th element. If $Count = 1$, this sets $first\ value (=last\ value)$ to the element.

- Assign Linear Values FROM [*value of first element*] STEP [*step value*]

This sets $first\ value + (N-1) \times step$ to the N -th element.

Add String Variable button displays the String Variable area that provides the following fields.

- Name: String variable name
- Value: Initial value of the variable
- Description: Additional information for the variable

Add Module Variable button displays the Module Variable area that provides the following fields.

- Name: Module variable name
- Description: Additional information for the variable

Editing test contents

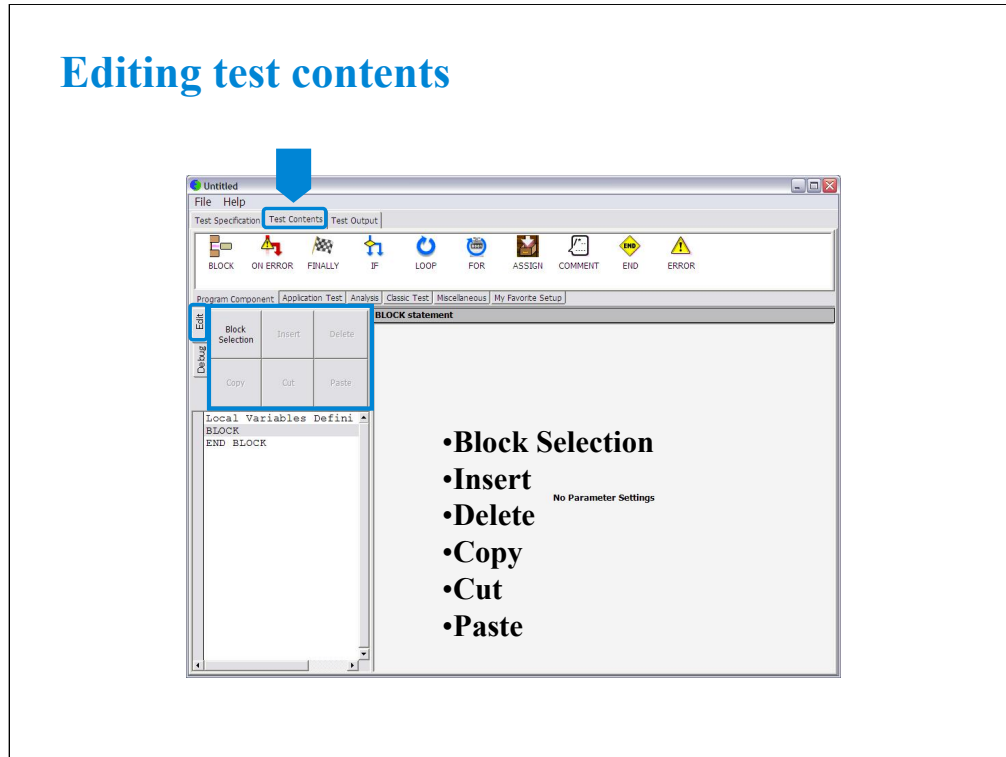

The Edit tab provides the following buttons:

- Block Selection/Line Selection toggle button selects the edit target selection mode. In the line selection mode, clicking line just selects the line. In the block selection mode, clicking line selects the block the line belongs to.
- Insert button inserts the specified element between the highlighted line and the next line.
- Delete button deletes the highlighted line.
- Copy button copies the highlighted line to the clipboard.
- Cut button moves the highlighted line to the clipboard.
- Paste button inserts the line in the clipboard between the highlighted line and the next line.

Debug menu

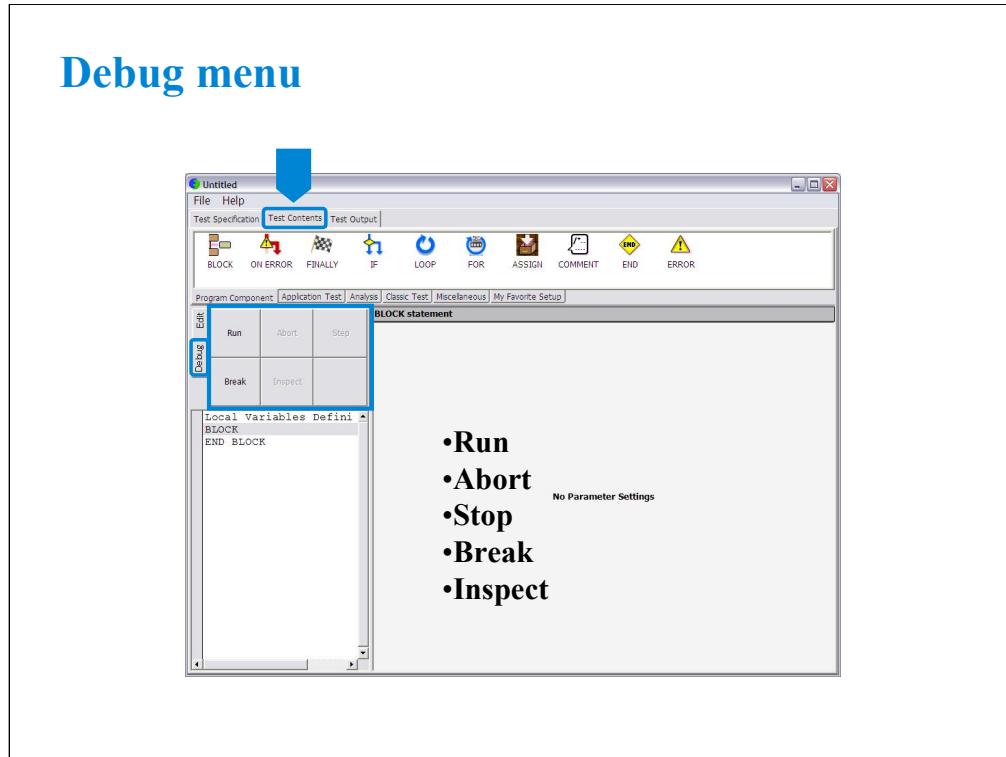

The Debug tab menu provides the following buttons:

- Run button starts the debug (executes the test flow). During execution, the label changes to Pause. Clicking Pause button pauses the execution, and changes the label to Run that is used to continue the debug (execution).
- Abort button aborts the debug (execution).
- Step button executes the highlighted line of the test flow. Clicking the button repeatedly continues the execution by a line.
- Break button sets/releases the break point. For the break point, this button releases the break point from the highlighted line. Program execution will break at the break point automatically.
- Inspect button is available when the debug (execution) is paused or broken. This button opens the Variable Inspector used to monitor value of device parameters, test parameters, analysis parameters, local variables, or system variables.

Class Exercise

Create test definition and perform test.

1. Open test definition editor.
2. Define Test Specification (see previous page)
3. Define Test Contents shown below.
4. Save the definition as Trng idvd idvg.
5. Use debug tools to check the definition.
6. Connect device, and perform test.

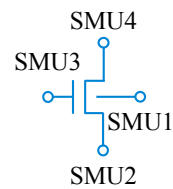

Test Contents:

Local Variables Definition

```
BLOCK
  IDVD
  Message
  IF Yes=0
    END
  END IF
  GMMAX
END BLOCK
```

Test Definition Example

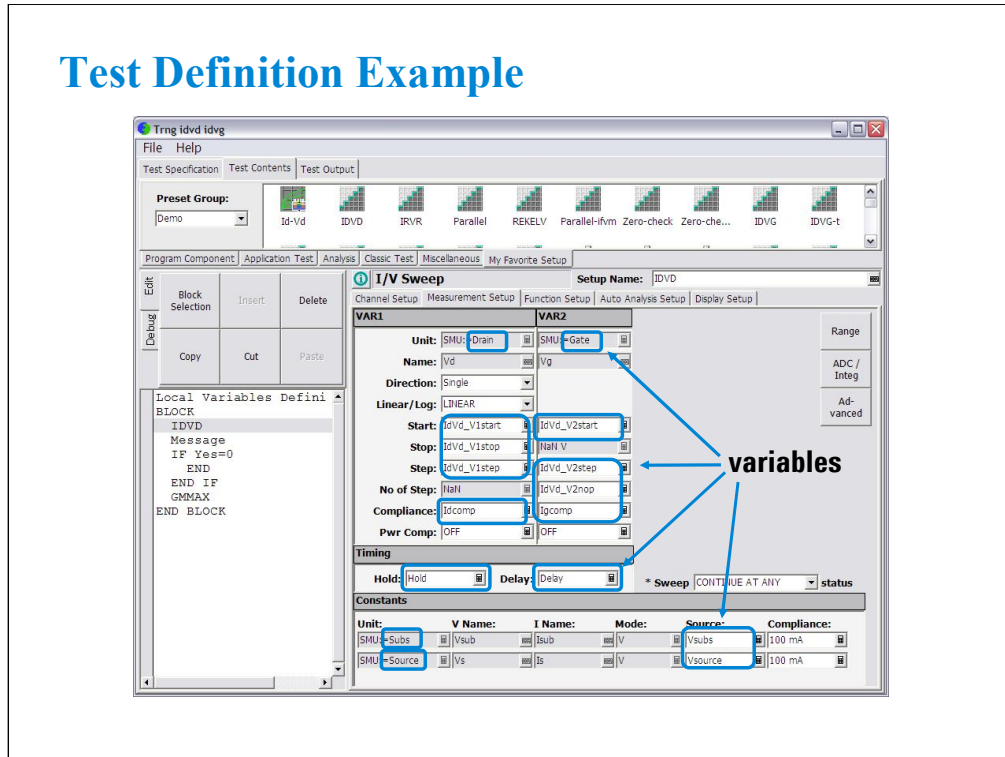

Use IDVD and GMMAX in the Demo preset group (My Favorite Setup) for the test setup.

Use the variables defined in the Test Specification to set the Unit on the Channel Setup, the source values on the Measurement Setup, the Min and Max values on the Display Setup, and so on.

For the example definition, open the Trng idvd idvg definition stored in the %data folder on the Manual CD. The Manual CD stores the example test setup and definition data used in this manual.

Measurement Result Example

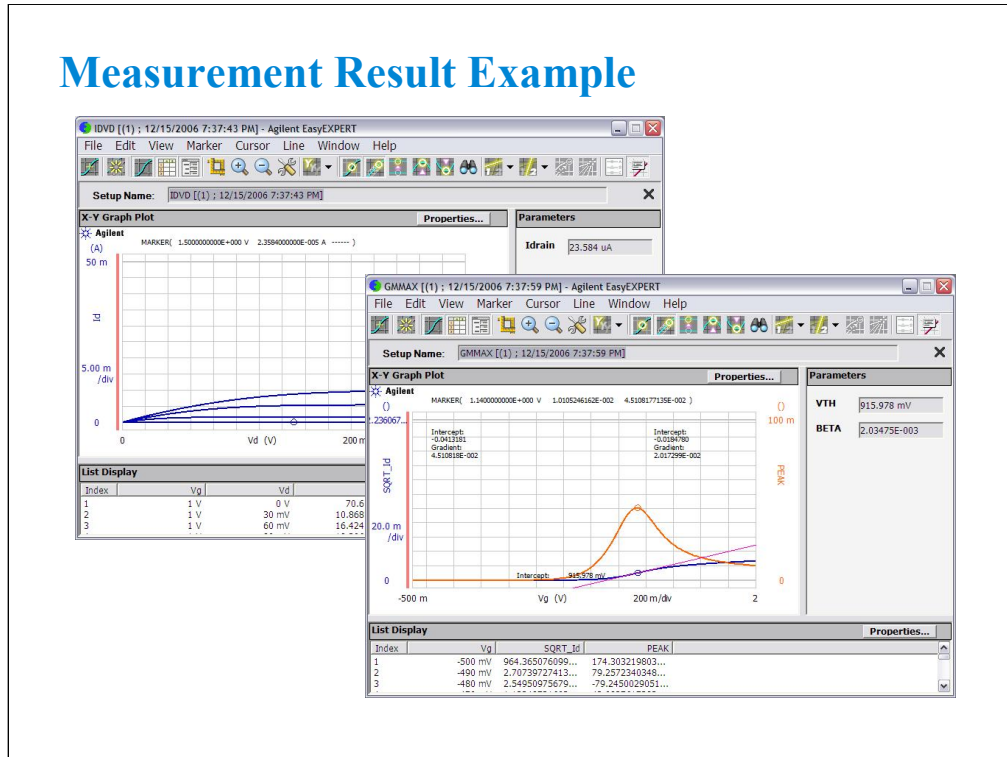

This is a test result example displayed on the Data Display window.

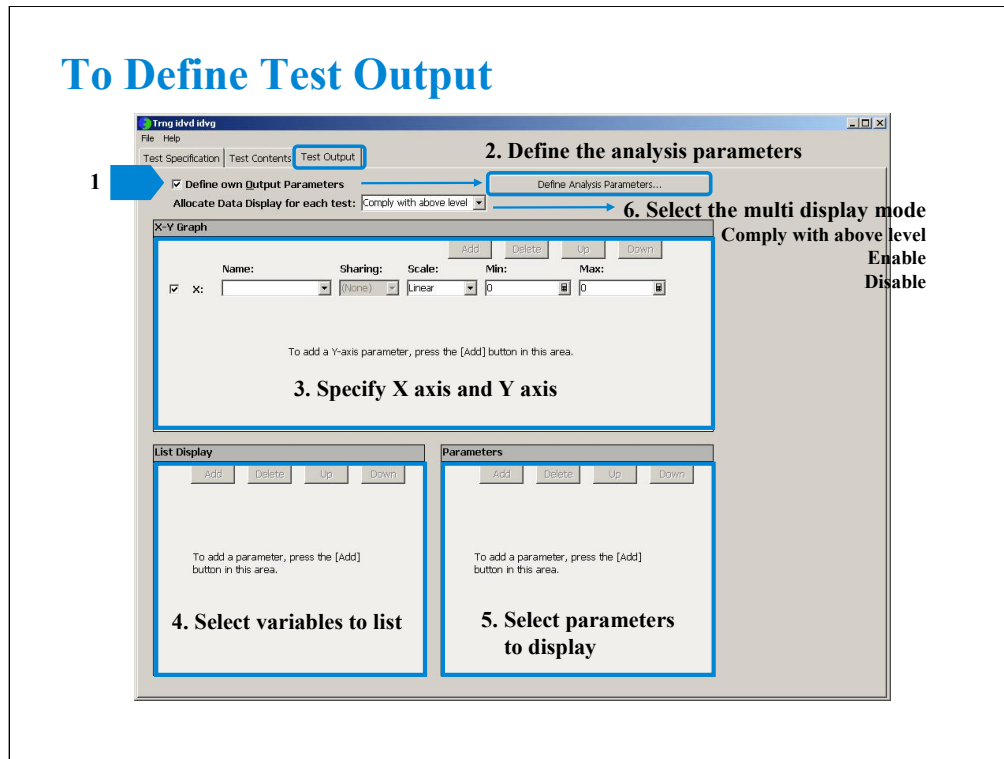

The test output setup is optional. If you have the following requirements, define the analysis parameters and set the display parameters.

- To send the test result data to the subsequent tests in an application test
- To make the program branching depends on the test result
- To make the calculation using the test data in the Test Contents
- To display/record the test result of this application test
- To change the multi display mode of this application test

To define the test output:

1. Check the Define own Output Parameters box.
2. Click the Define Analysis Parameters... button. And define the analysis parameters on the Analysis Parameter Definition window.
3. Specify X axis and Y axis of the X-Y Graph of the Data Display window.
4. Select variables to list in the List Display area of the Data Display window.
5. Select variables to display in the Parameters area of the Data Display window.
6. Select the multi display mode using the Allocate Data Display for each test pull-down menu.

Note: If the multi display mode is Disabled, the all test result data will be displayed on the singular Data Display window. If the multi display mode is Enabled, the test result data of the same test setup name will be displayed on the exclusive Data Display window and the test result data of the different test setup name will be displayed on the new Data Display window.

To Define Test Output Analysis Parameters

Define Analysis Parameters...

Vector Parameters		
Name:	Unit:	Description
VG	V	Gate Voltage
ID	A	Drain Current
GM	S	Transconductance
GM_MAX	S	Maximum Transconductance

Scalar Parameters		
Name:	Unit:	Description
VTH	V	Threshold Voltage

Define the analysis parameters as shown below:

At the Vector Parameters area or the Scalar Parameters area:

1. Click the Add button.
2. Enter the Name, Unit, and Description of the parameter.

For the sweep output/measurement data, use the vector parameter.

For the spot output/measurement data, use the scalar parameter.

For the data given by the max() and min() built-in function, use the vector parameter.

In this example, VG, ID, and GM are the vector parameter and VTH is the scalar parameter.

GM_MAX is the vector parameter because the max() built-in function is used to calculate this value.

To Define Test Output Display Parameters

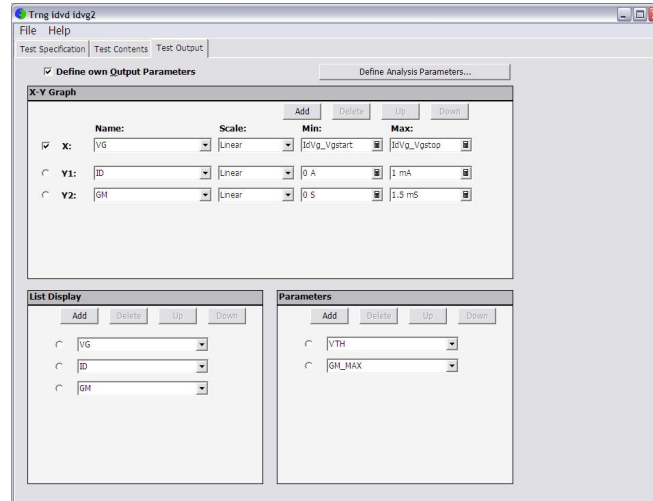

This example sets:

X-Y Graph: ID-VG plot for Y1-X graph and GM-VG plot for Y2-X graph

List Display: VG, ID, and GM

Parameters: GM_MAX and VTH

All parameters must be defined in the Analysis Parameter Definition window shown in the previous slide.

The X-Y Graph area is used to set the X axis and Y axis of the X-Y Graph Plot area on the Data Display window.

- Name: Name of variable to plot on the X axis
- Scale: Linear or Log
- Min: Minimum value of the specified axis
- Max: Maximum value of the specified axis

The List Display area selects the variables to be listed on the List Display area of the Data Display window. Up to 20 variables can be set.

The Parameters area selects the variables to be listed on the Parameters area of the Data Display window. Up to 20 parameters can be set.



7

Advanced Definitions and Operations

In This Module

- **To Control External GPIB Devices**
- **To Call Execution Files**
- **To Perform Repeat Measurements**
- **Prober Control Script**
- **Thermo-trigger**

To Control External GPIB Devices

Miscellaneous: GPIB I/O

Write String	to send a string command to GPIB device
Write Value	to send a command to GPIB device
Read String	to read a string value from GPIB device
Read Value	to read a numeric value data from GPIB device
Read List	to read a vector data from GPIB device
Read STB	to read status byte of GPIB device
GP-IB Control	Group Execution Trigger
	Device Clear
	Go To Local
	Local LockOut

You can control external GPIB devices from the EasyEXPERT by using the GPIB I/O statement. The GPIB I/O statement provides the write/read functions shown above. Select a write function and enter the necessary parameters to send a command to the GPIB device. Select a read function and enter the necessary parameters to read response from the GPIB device. For details, see online help or User's Guide.

The followings are the GPIB Control functions.

- Group Execution Trigger: Sends a trigger to the specified GPIB device.
- Device Clear: Sends a device clear to the specified GPIB device.
- Go To Local: Returns the specified GPIB device to the local state.
- Local LockOut: Locks the specified GPIB device.

Note: Before starting, enable System Controller. See Module 8. Also establish the GPIB connection with the external GPIB devices.

To Control External GPIB Devices

Agilent B2200 control example

To send command

Programming image:

```
*RST
:ROUT:FUNC ACON
(enter "SMU1" to StringPort)
:ROUT:SYMB:PORT {0},{1}"
:ROUT:SYMB:PORT? {0}
(reads string data)
*OPC?
(reads operation complete flag)
(enter "OUT1" to StringCh)
:ROUT:SYMB:CHAN {0},{2},"{1}"
:ROUT:SYMB:CHAN? {0},{2}
(reads string data)
*OPC?
(reads operation complete flag)
```

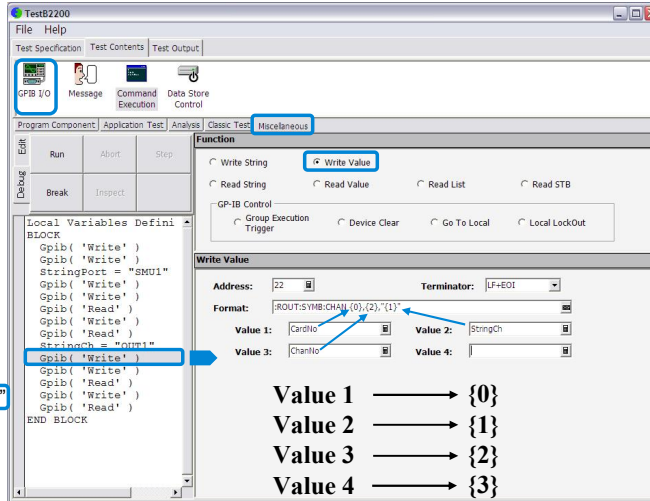

This slide shows an example setup of the GPIB I/O statement. This is a component of the test contents used to control the Agilent B2200 switching matrix.

This example uses the Write Value function to send the following command to the B2200.

```
:ROUT:SYMB:CHAN {0},{2},\"{1}\"
```

where, {0} is CardNo, {1} is StringCh, and {2} is ChanNo.

The followings are the reference of the setup editor.

- Address: GPIB address of the device
- Terminator: EOI, LF, CR/LF, LF+EOI, CR/LF+EOI, or NONE (no terminator)
- Format: Command (header and parameters) sent to the device
- Value 1: Value for {0}
- Value 2: Value for {1}
- Value 3: Value for {2}
- Value 4: Value for {3}

{0}, {1}, {2}, and {3} are variable available in the Format field only.

Note: Use double quotes to enter a string to a local variable by using the Assign statement.

To Control External GPIB Devices

Agilent B2200 control example

To read data

Programming image:

```
*RST
:ROUT:FUNC ACON
(enter "SMU1" to StringPort)
:ROUT:SYMB:PORT {0},{1}"
:ROUT:SYMB:PORT? {0}
(reads string data)
*OPC?
(reads operation complete flag)
(enter "OUT1" to StringCh)
:ROUT:SYMB:CHAN {0},{2},"{1}"
:ROUT:SYMB:CHAN? {0},{2}
(reads string data)
*OPC?
(reads operation complete flag)
```

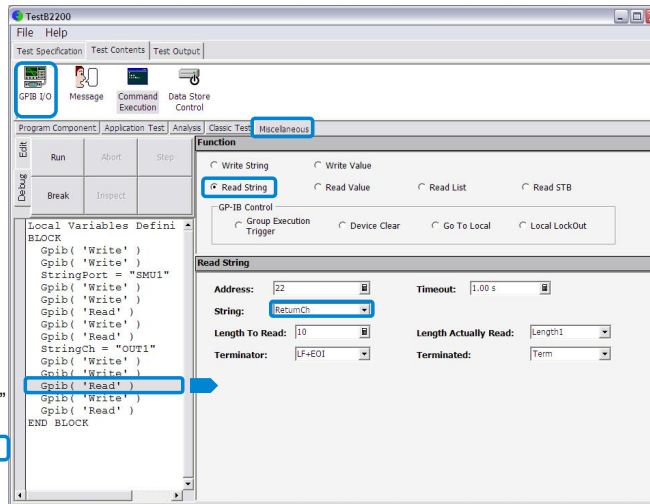

This example uses the Read String function to read the response from the B2200. This example reads the :ROUT:SYMB:CHAN? query command response. The result (ReturnCh value) must be OUT1.

To Call Execution Files

Miscellaneous: Command Execution

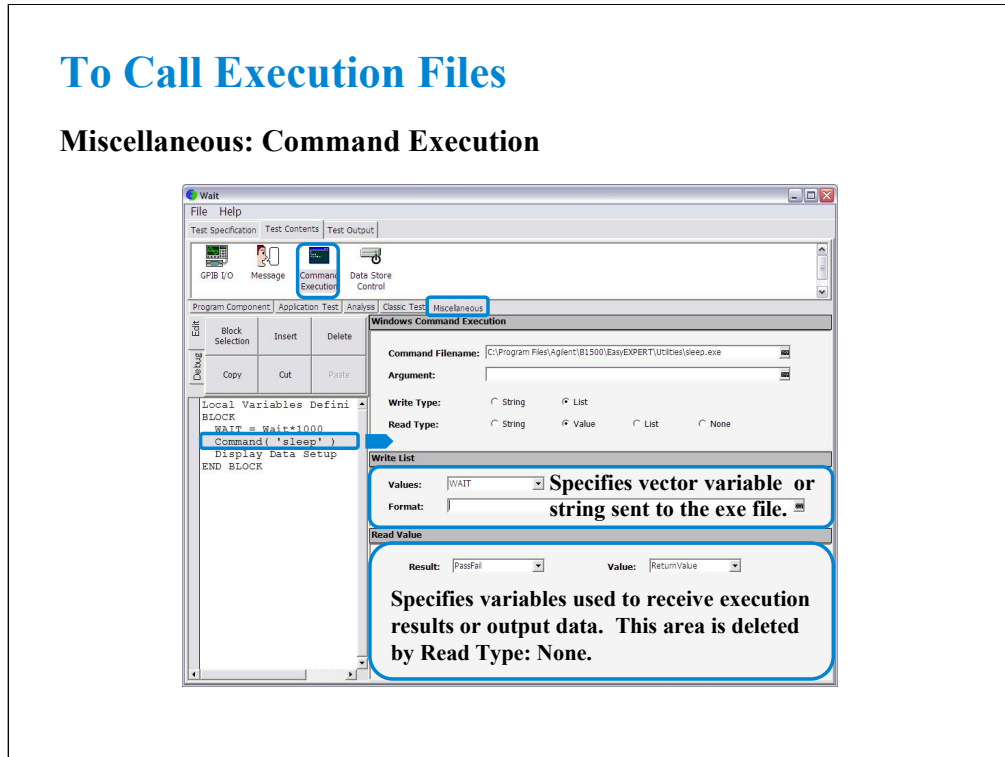

You can call the execution file (EXE file) from the EasyEXPERT. Use the Command Execution statement and define the setup editor as shown in this example.

- Command Filename: Execution file name (command name)
- Argument: Command parameter or argument
- Write Type: String or List (vector data)
- Read Type: String, Value (numeric data), List (vector data), or None (no read data)

If you specify Write String, enter the string sent to the command.

If you specify Write List, enter the name of vector variable sent to the command, and specify the format of data element sent to the command. See next slide.

In the Read String/Value/List area, specify the variables used to receive execution result and output data. There is no entry field for Read Type: None.

- Result: Numeric variable name. Used to store the execution result.
- Value: Numeric variable name for Read Value, or vector variable name for Read List. Used to store the returned data.
- String: String variable name. Used to store the returned data.
- Length Actually Read: Numeric variable name. Used to store the byte length of the returned data.

The above example calls the sleep.exe file used to insert the wait time for program execution. The WAIT value must be defined in msec. After the normal command execution, the sleep.exe returns 1 for Value and 0 for Result. The sleep.exe file is stored in the following folder.

C:\Program Files\Agilent\B1500\EasyEXPERT\Utilities

To set Format field

{I[,A][:F]}

- **I** List data index. Or index of element. Integer.
- **A** Character length of the specified data element. Positive integer for right-aligned, or negative integer for left-aligned. Optional.
- **F** Format identifier. C, D, E, F, G, N, P, R, or X. Lower case is available. Optional.

Example:

{0,5:E} First element, 5 characters, exponential notation.

{1:G} Second element, general.

{2,10} Third element, 10 characters, general.

The Format field is used to specify the data format of List (vector variable). The strings shown in the above example can be defined in the Format field.

In the strings, the list data index is mandatory. The character length and format identifier are omissible. Then the length is not limited, and the format G is set.

C or c: Circulation

D or d: Decimal numeral

E or e: Exponential notation

F or f: Fixed point

G or g: General

N or n: Numeric

P or p: Percent

R or r: Round trip

X or x: Hexadecimal numeral

Exercise

Try to improve your test definition as you want.

- **To Use Built-in Functions**
- **To Use Read Out Functions**
- **To Control External GPIB Devices**
- **To Call Execution Files**

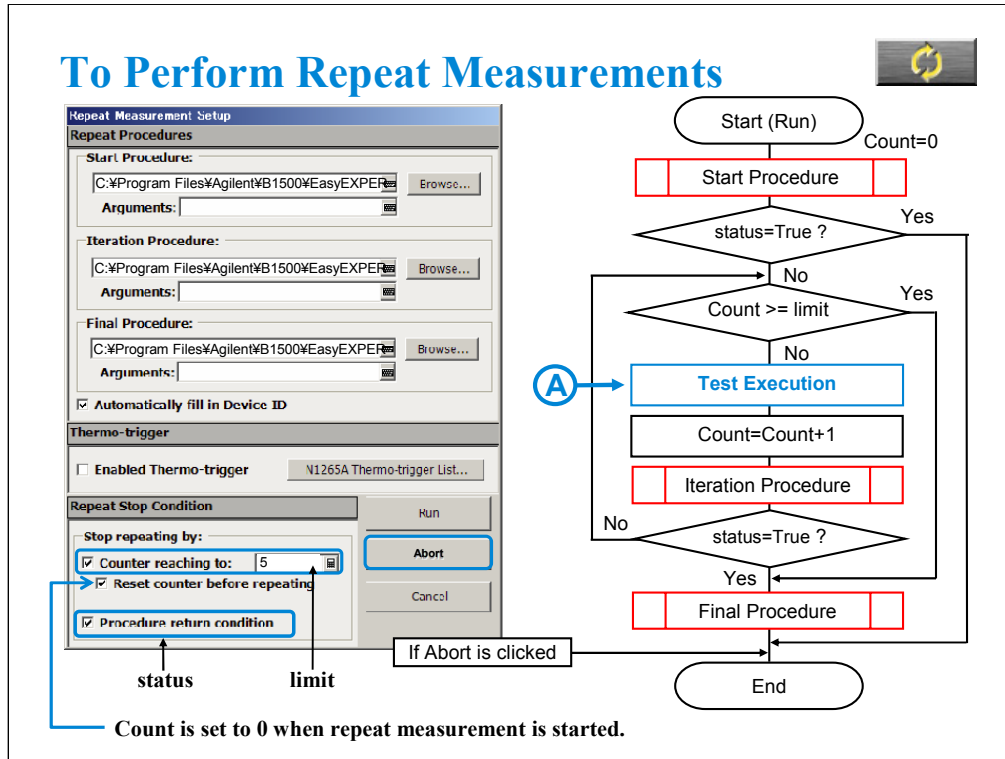

Repeat measurement is performed as shown in this flowchart. The status is a response returned by the start/iteration procedure. The Count is the accumulated number of test executions. They are the stop condition of the repeat measurement.

The repeat measurement stop function is enabled by the following check boxes.

- Counter reaching to
- Procedure return condition

If the first box is checked and the limit value is specified, the repeat measurement will be stopped if $Count \geq limit$. To perform the repeat measurement, set the limit value more than the number of devices under test or remove check from this box.

If the second box is checked, the repeat measurement will be stopped if $status = True$.

When the second box is checked, the device ID automatic setup function is available and is enabled/disabled by the Automatically fill in Device ID check box. The function enters the device_id value to the Device ID of the test result record. The device_id is a response returned by the start/iteration/subsite procedure.

The Repeat Measurement Setup dialog box provides the following action buttons.

- Run: Starts repeat measurement.
- Abort: Stops repeat measurement immediately.
- Cancel: Closes the Repeat Measurement Setup dialog box.

Start/Iteration/Final Procedure:

Enter the full path name of the procedure. For example, enter as follows.

C:\Program Files\Agilent\B1500\EasyEXPERT\Utilities\ProberControl\suss\Start_suss.exe

Arguments:

Enter the options of the procedure. See the following pages describing about procedures. For example, enter `-a GPIB0::5::INSTR -l C:\temp\prb.log`.

For the sub die move operation (subsite procedure), see page 7-18. Flowchart is changed.

For the Thermo-trigger, see page 7-19.

Subsite move Test Setup

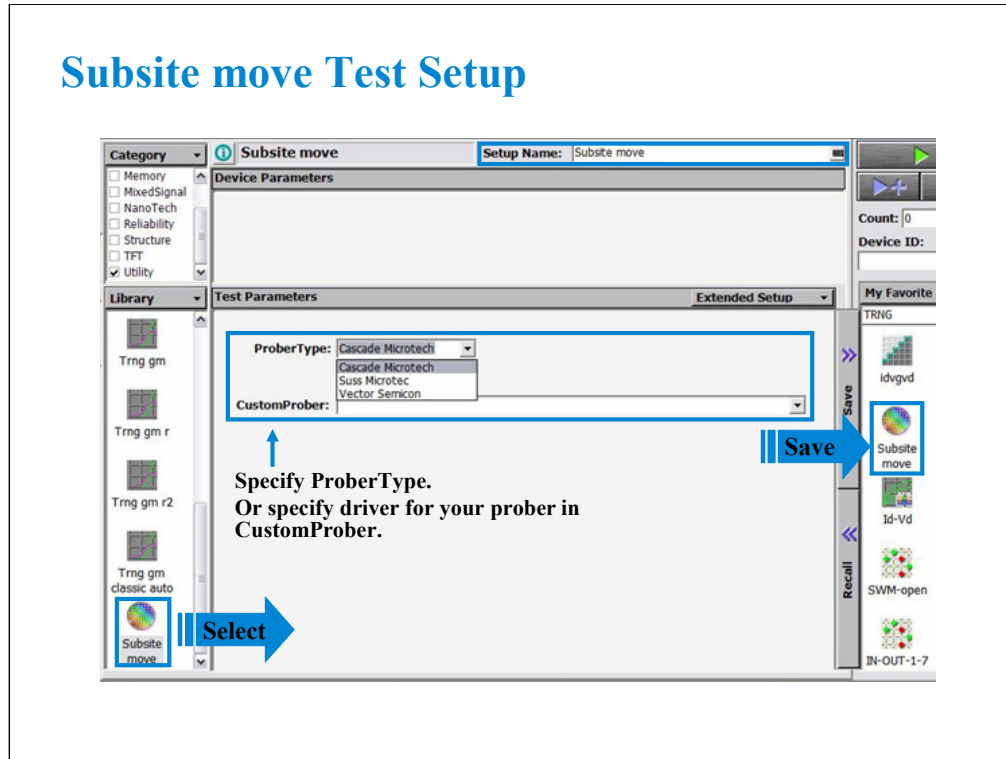

If you do not use the sub die (subsite) move operation, skip this page.

Click Application Test tab and open the Subsite move test setup in the Utility category. On the Subsite move setup screen, specify ProberType (Cascade, Suss, or Vector) or driver for your prober in CustomerProber, and save it as a setup in your preset group (My Favorite Setup). Then you can use the setup for your quick test. See next page.

The Subsite move setup moves wafer chuck to the next subsite, reads device ID from the prober, and sets it to the Device ID of the test result record.

For more details of the test setup, open the Test Definition window.

In the Subsite move test definition, an execution file callProbeDvr.exe is used. This file is used to send Subsite_xxxx.exe to the prober specified by the prober_info.ini file and receive the response; status and device_id. The callProberDvr.exe has the following input/output parameters.

Input: Full path of Subsite_xxxx.exe

Output: status; True (break) or False

Output: device_id

Note: The callProberDvr.exe refers to the prober_info.ini file for the GPIB address and log file name. Do not set the Arguments of Subsite_xxxx.exe.

To Use Subsite move

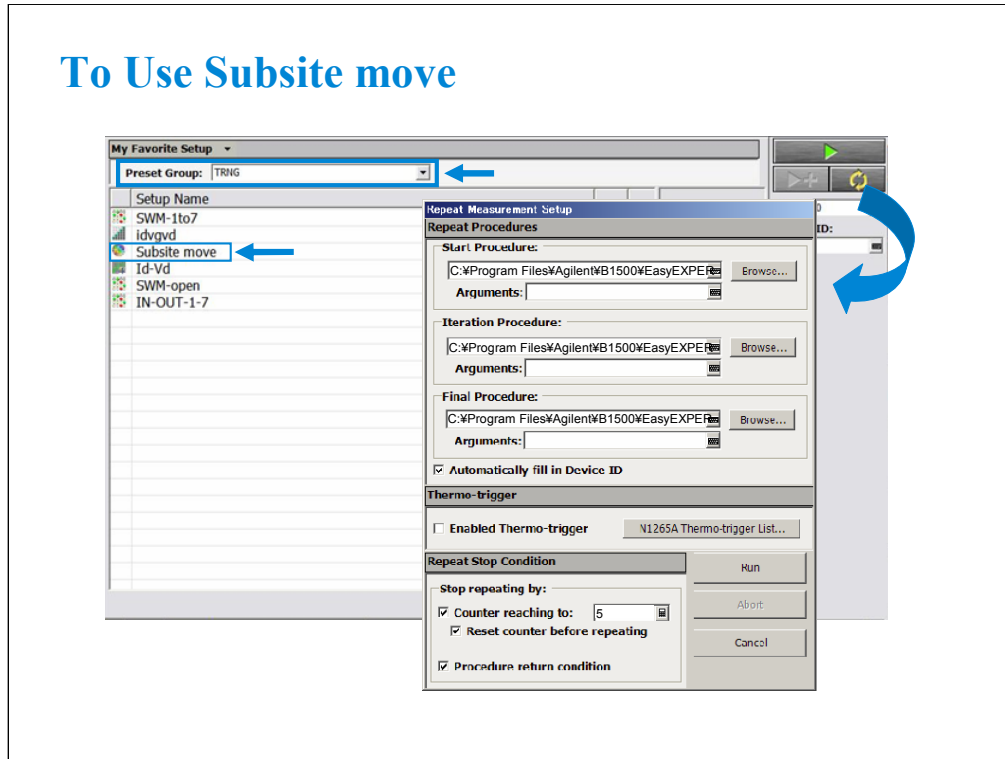

If you do not use the sub die (subsite) move operation, skip this page.

To perform the test with the sub die move operation, do as follows.

1. Add the Subsite move test setup to your preset group (My Favorite setup).
2. Set your preset group and test setups in the Quick Test tab screen.
3. Open the Repeat Measurement Setup dialog box.
4. Specify the procedures and the repeat measurement condition.
5. Start repeat measurement.

The Subsite move setup must be entered after measurements for a sub die.

Prober Control Script

- **Prober information file** **Use prober control script in EasyEXPERT Repeat Measurement Setup window**
 prober_info.ini
 - **Start Procedure**
 Start_XXXX.exe
 - **Iteration Procedure**
 Iterator_XXXX.exe
 - **Final Procedure**
 Final_XXXX.exe
 - **Subsite Procedure**
 Subsite_XXXX.exe
- XXXX:**
- **cascade**
 - **suss**
 - **vector**



Prober control script is sample program used for semi-automatic prober control. The Agilent EasyEXPERT can call the script by using the Repeat Measurement Setup window.

See page 7-9 to call the script and perform repeat measurement.

See page 7-14 for the prober information file.

See page 7-13 for the start procedure.

See page 7-15 for the iteration procedure.

See page 7-16 for the final procedure.

See page 7-17 for the subsite procedure.

To use the prober control script, specify the start/iteration/final procedure in the Repeat Measurement Setup dialog box (see page 7-9). And use the Subsite move test setup in your quick test to control sub die move. The Subsite move setup uses the subsite procedure for moving wafer chuck to the next subsite. See page 7-10 and 7-11.

Start_xxxx.exe

- Arguments: `-a GPIB_address`
`-l log_file_name`

Example:

`-a GPIB0::5::INSTR -l C:\temp\prb.log`

- Response: XML format data

```
<Response>
  <Break>status</Break>
  <Target>device_id</Target>
</Response>
```

status: True (break) or False
device_id: prefix:coordinate

Example:

```
<Response>
  <Break>False</Break>
  <Target>waf1a:3 1</Target>
</Response>
```

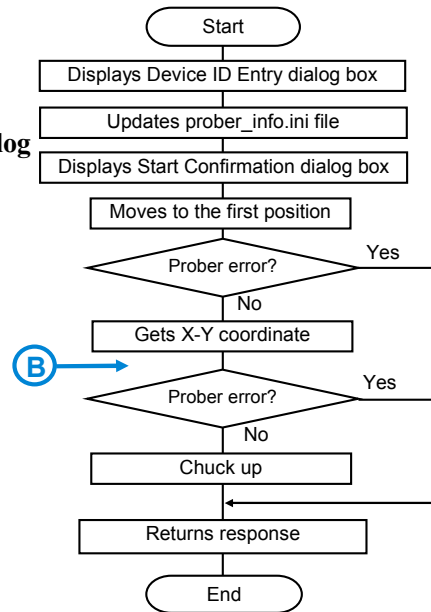

To specify the start procedure in the Repeat Measurement Setup dialog box, enter the full path name of Start_xxxx.exe into the Start Procedure field.

After the repeat measurement is started, this procedure displays the Device ID Entry dialog box and waits for your input. On the dialog box, enter a string used for the prefix of device_id. After that, you will see the Start Confirmation dialog box that is used to confirm your wafer setup status. Load wafer and perform wafer alignment, then click OK on the dialog box. The procedure moves wafer chuck to the first probing position, checks the prober status, gets the X-Y coordinate of the probing position, and sets the wafer chuck to the UP position. At last, the procedure returns the response.

The status is True or False. It is used for the EasyEXPERT repeat measurement stop function. When the Procedure return condition box is checked in the Repeat Measurement Setup dialog box, the repeat measurement will be stopped if status = True.

The device_id is a string for the Device ID of the test result record. When the Automatically fill in Device ID box is checked in the Repeat Measurement Setup dialog box, the device_id will be entered to the Device ID of the test result record.

For the sub die move operation (subsite procedure), see page 7-18. Flowchart is changed.

Note: To ignore the Arguments, set the GPIB address and log file name in the prober_info.ini.

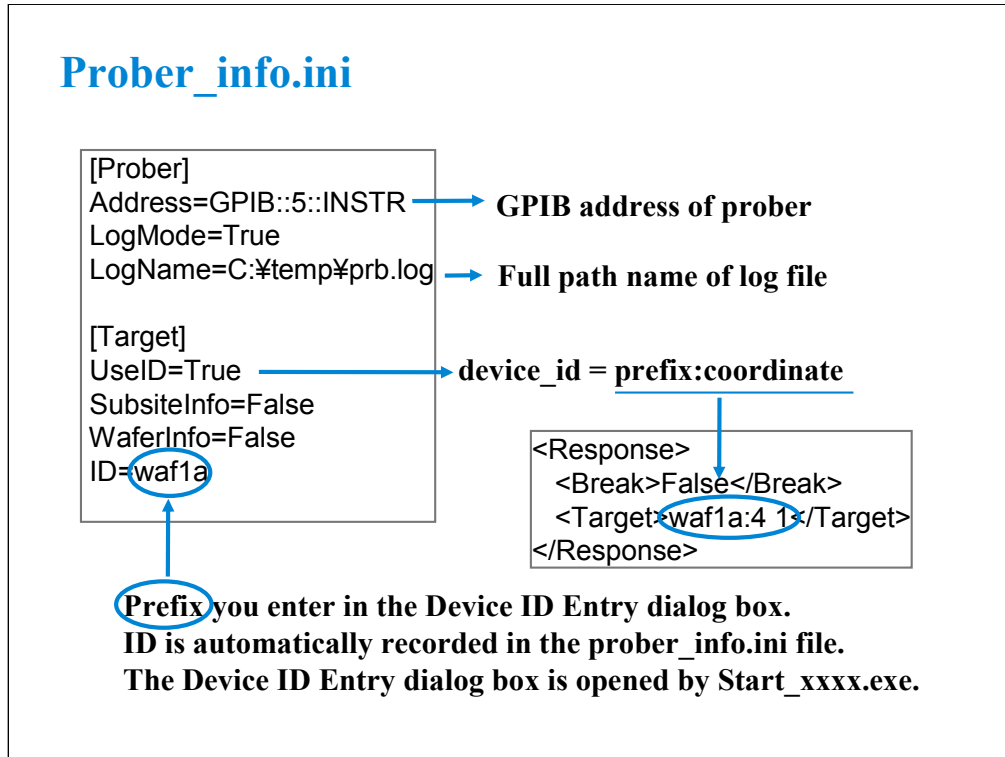

The prober information file is necessary to execute the prober control script. Before starting tests, open this file, edit it as you want, and overwrite it. The name must be prober_info.ini.

The prober_info.ini file stores the information shown below.

- Address: GPIB address of prober
- LogMode: Log file creation mode; True or False
- LogName: Log file name (full path)
- UseID: Device ID creation mode; True or False
- SubsiteInfo: Set always False. This is just a place holder.
- WaferInfo: Set always False. This is just a place holder.
- ID: Ignore this variable. This is just a pass parameter.

If the procedures specify the -a option, the Address value is not used.

If the procedures specify the -l option, the LogName value is not used.

To create a log file, set LogMode=True.

To use the prefix:coordinate format for the device_id value, set UseID=True. If UseID=False, the device_id value will be coordinate, not prefix:coordinate. The prefix will be the value entered in the Device ID Entry dialog box that is opened by Start_xxxx.exe. This function is available when the Automatically fill in Device ID check box is checked.

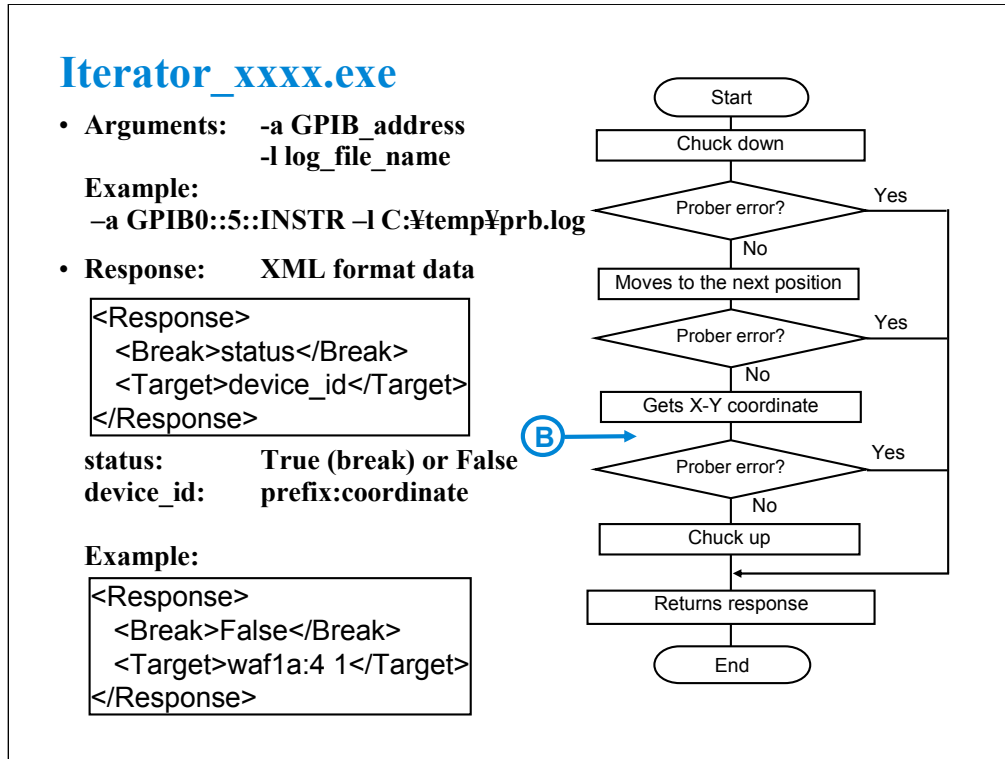

To specify the iteration procedure in the Repeat Measurement Setup dialog box, enter the full path name of Iterator_xxxx.exe into the Iteration Procedure field.

The procedure is called after the measurement is completed for a die. This procedure sets wafer chuck to the DOWN position, moves it to the next probing position, checks the prober status, gets the X-Y coordinate of the probing position, and sets the wafer chuck to the UP position. At last, the procedure returns the response.

The status is True or False. It is used for the EasyEXPERT repeat measurement stop function. When the Procedure return condition box is checked in the Repeat Measurement Setup dialog box, the repeat measurement will be stopped if status = True.

The device_id is a string for the Device ID of the test result record. When the Automatically fill in Device ID box is checked in the Repeat Measurement Setup dialog box, the device_id will be entered to the Device ID of the test result record.

For the sub die move operation (subsite procedure), see page 7-18. Flowchart is changed.

Note: To ignore the Arguments, set the GPIB address and log file name in the prober_info.ini.

Final_xxxx.exe

- Arguments: -a GPIB_address
-l log_file_name

Example:

-a GPIB0::5::INSTR -l C:\temp\prb.log

- Response: none

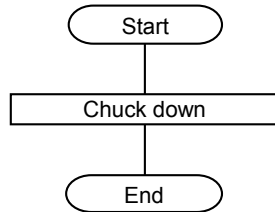

Stop condition

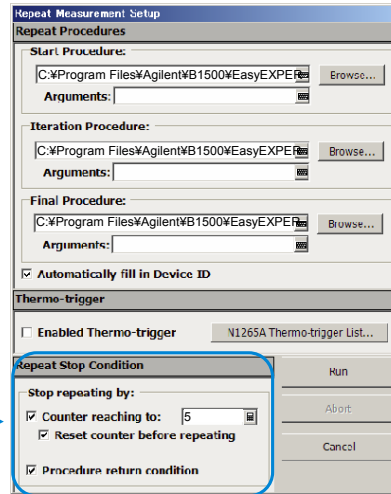

To specify the final procedure on the Repeat Measurement Setup dialog box, enter the full path name of Final_xxxx.exe into the Final Procedure field.

The procedure is called after one of the stop condition is detected. This procedure sets wafer chuck to the DOWN position.

Note: To ignore the Arguments, set the GPIB address and log file name in the prober_info.ini.

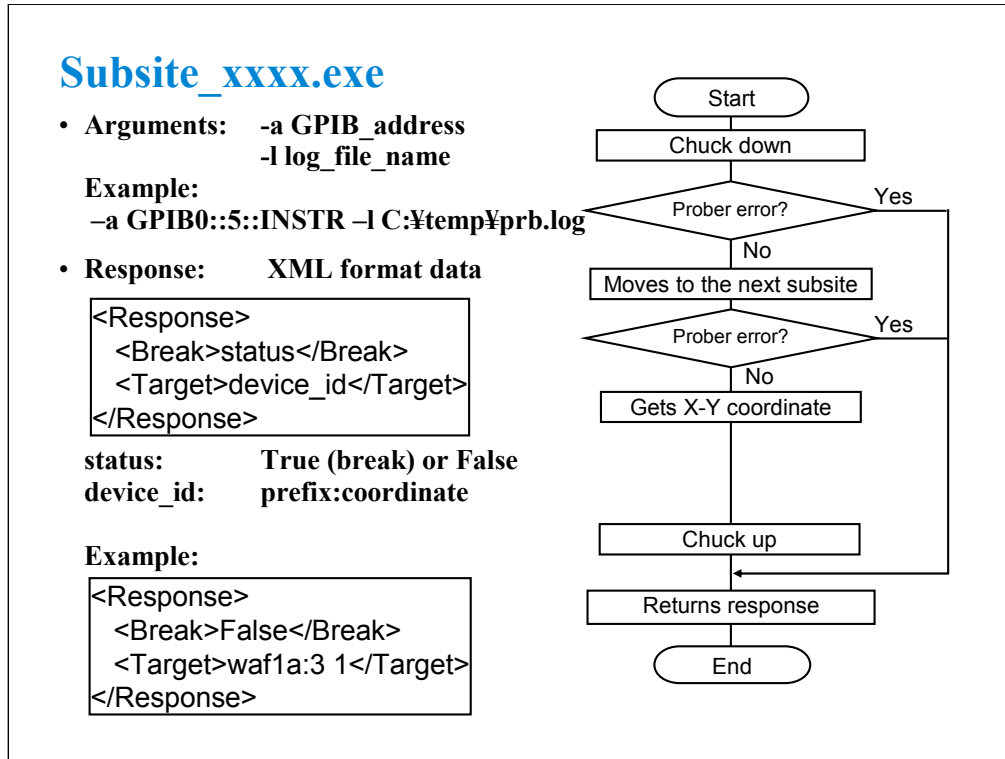

To realize sub die move operation, you need to define Subsite_xxxx.exe in your test definition and create your application test setup. However, you do not need to take care of this procedure by using the Subsite move test setup included in the application library. The Subsite move setup moves wafer chuck to the next subsite, reads device ID from the prober, and sets it to the Device ID of the test result record.

Open the Subsite move test setup and save it as a setup in your preset group (My Favorite Setup). Then you can use the setup for your quick test.

Note: To use the Subsite move setup, set the GPIB address and log file name in the prober_info.ini. And ignore the Arguments for Subsite_xxxx.exe.

Note: If you use a Suss prober, the number of Subsite move setups used in your quick test (die test) is important. It must be N-1; N is the number of subsites defined in the prober.

The status is True or False. It is used for the EasyEXPERT repeat measurement stop function. When the Procedure return condition box is checked in the Repeat Measurement Setup dialog box, the repeat measurement will be stopped if status = True.

The device_id is a string for the Device ID of the test result record.

To Change Execution Flow

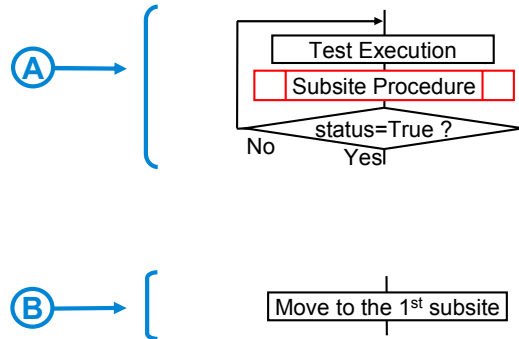

To use the subsite procedure, change the flowchart as follows.
On the page 7-9, replace the box A with the block A shown above.
On the page 7-13 and 7-15, insert the box B shown above to the position B of the flowchart.

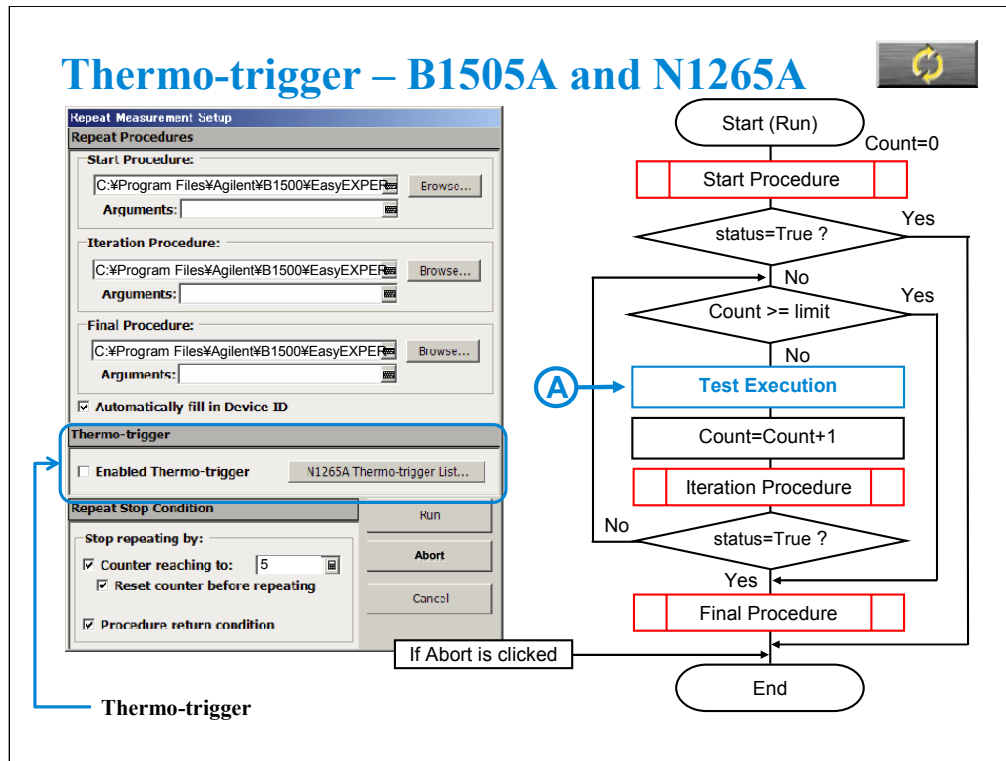

Thermo-trigger function is valid only when the N1265A ultra high current expander/fixture is used. If this function is enabled, the repeat measurement execution flow is changed. See the next page. The following steps are added.

1. After Count is judged, temperature (Temp) is measured.
2. If the measured temperature is in the range of the temperature condition (Center and Radius), the action (Action) is executed after the delay time (Delay) elapsed. Or else, the temperature measurement and this judgement are repeated.

The terms in () are the parameters you can set by using the dialog box opened by clicking the N1265A Thermo-trigger List button. The dialog box is shown in the next page.

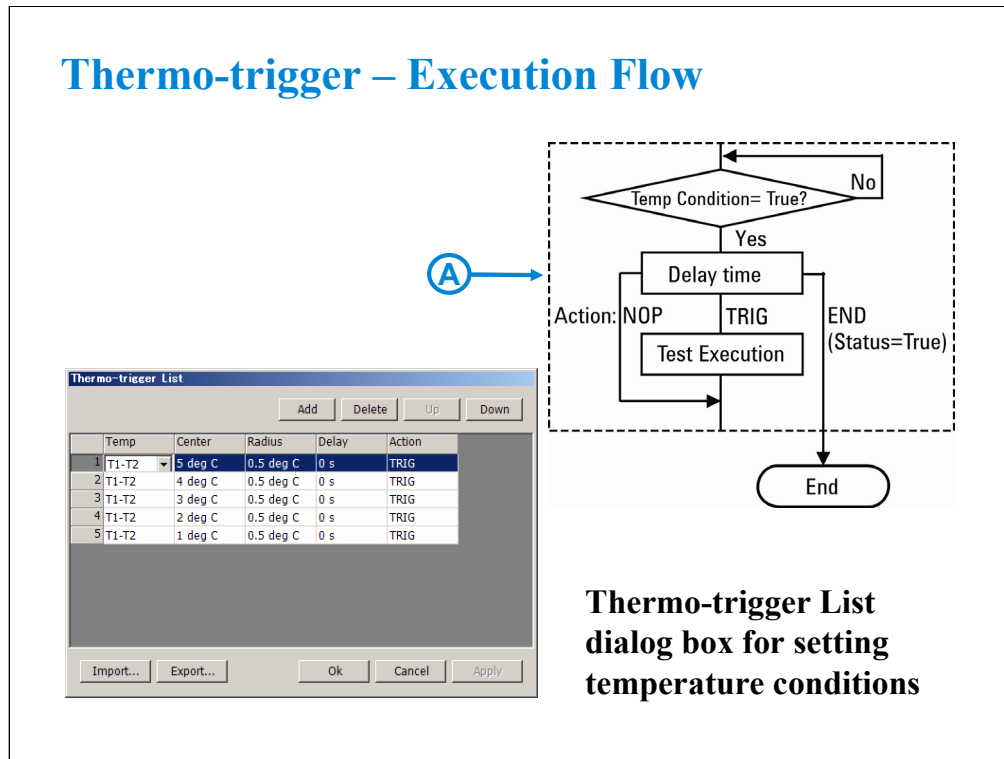

To use the Thermo-trigger, change the flowchart as follows.
On the page 7-19, replace the box A with the block A shown above.

The Thermo-trigger List dialog box is used to set the temperature conditions. You can set a maximum of 1001 conditions.

Temp specifies T1, T2, or T1-T2.

T1: Temperature value measured by the thermometer channel 1.

T2: Temperature value measured by the thermometer channel 2.

T1-T2: Difference between T1 and T2.

Center and Radius specify the temperature range, Center +/- Radius.

Delay specifies the delay time before Action is executed.

Action specifies TRIG, NOP, or END.

TRIG: Does the single test execution after the specified delay time, and then goes to the next operation. This is useful to do the single test execution in the specified temperature range.

NOP: No operation (single test execution is skipped). Waits for the delay time, and goes to the next operation. This is useful to wait in the specified temperature range.

END: Sets the status to True, and exits the repeat measurement after the delay time. This is useful to exit the repeat measurement in the specified temperature range.



8 Miscellaneous Operations



In This Module

- **Function Status Indicators**
- **Run Option**
- **Automatic Data Export and Data Record**
- **Calibration**
- **Configuration**
- **XSLT Filters**
- **To Enable System Controller**
- **To Start Desktop EasyEXPERT**
- **To Use 415x Setup File Converter**

This module describes the above topics. You will understand what is the function status indicator, how to change the function status, how to perform selftest and calibration, how to perform SMU zero offset cancel, and so on.

Function Status Indicators

	Date	Count	Device ID	Remarks
	2009/09/18 16:59:38	1		Id-Vd
d	2008/10/02 16:20:46	1		
4T 0.1V step	2008/02/05 11:24:50	1		
	2008/02/01 20:36:02	1		
	2008/02/01 20:36:02	1		
	2008/02/01 20:35:43	1		

Thermometer OFF ⇒ T1: XX deg C ⇒ T2: XX deg C ⇒ dT: XX deg C
Multi Display OFF ⇒ Multiple data display OFF ⇒ ON
Standby OFF ⇒ Standby function OFF ⇒ ON
SMU Zero OFF ⇒ SMU zero offset cancel OFF ⇒ ON
Auto Export OFF ⇒ Automatic data export OFF ⇒ ON
Auto Record ON ⇒ Automatic data record ON ⇒ OFF

Function status indicators let you know the status OFF or ON of the following functions. The indicators are placed at the bottom of the main screen.

Thermometer indicator shows the thermometer OFF status, temperature (T1 or T2) measured by the thermometer channel 1 or 2, or difference (dT) between temperature values measured by the channels 1 and 2.

T1, T2, or dT is shown while the Thermometer is enabled. They are toggled by clicking the indicator if the channels 1 and 2 are enabled. Where, XX indicates the temperature value.

Multi Display OFF/ON: Shows the multiple data display function OFF or ON status.

Standby OFF/ON: Shows the standby function OFF or ON status.

SMU Zero OFF/ON: Shows the SMU zero offset cancel function OFF or ON status.

Auto Export OFF/ON: Shows the automatic data export function OFF or ON status.

Auto Record ON/OFF: Shows the automatic data record function ON or OFF status.

Clicking indicator controls the function ON/OFF directly or opens the dialog box or window which controls the function status.

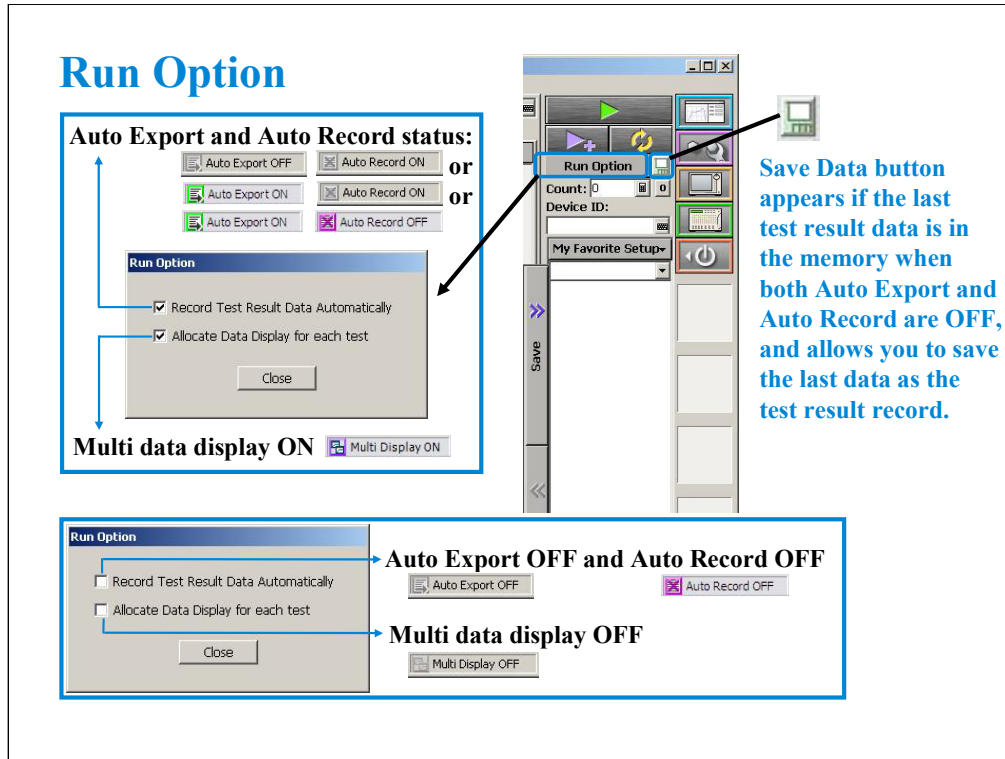

Run Option button opens the Run Option dialog box used to change the status of the automatic data record function, the automatic data export function, and the multiple data display function.

If the Record Test Result Data Automatically check box is checked, both or one of the automatic data record function and the automatic data export function will be set to ON. To specify the function status, see the next page.

If the Record Test Result Data Automatically check box is not checked, both functions are set to OFF. In this status, both data record and data export are not performed. So the test execution time will be reduced. Also, EasyEXPERT memorizes the last test result data. And it can be saved as a test result record by clicking the Save Data button right next to the Run Option button. This status will be useful for probe contact check, defect analysis, and so on.

The multiple data display function ON or OFF can be controlled by clicking the Multi Display indicator or by using the Allocate Data Display for each test check box on the Run Option dialog box.

About the multiple data display function:

If this function is OFF, the all test result data will be displayed on the singular Data Display window.

If this function is ON, the test result data of the same test setup name will be displayed on the exclusive Data Display window and the test result data of the different test setup name will be displayed on the new Data Display window.

Automatic Data Export and Data Record

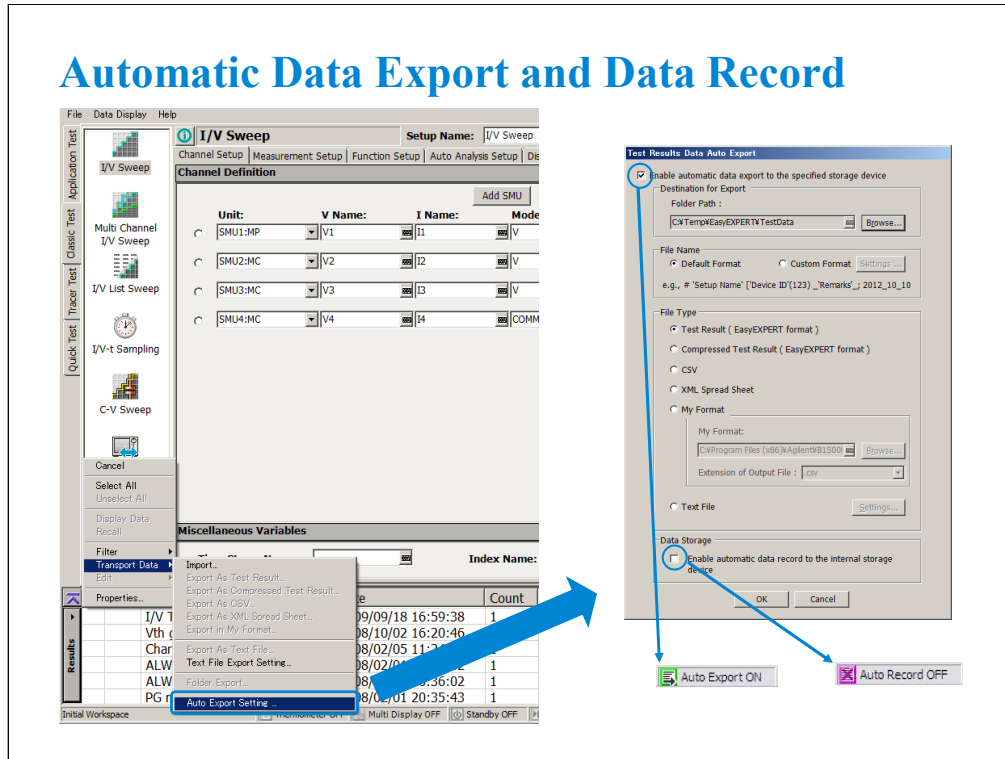

The automatic data export function and the automatic data record function can be enabled or disabled by using the Test Results Data Auto Export dialog box. This dialog box is displayed by clicking these indicators or selecting the Results > Transport Data > Auto Export Setting... menu.

The automatic data export function is used to export the test result data automatically to the storage device you specify. You can specify the destination (storage device), exported file name, and file type. To set the automatic data export function to enable (set to ON), check the Enable automatic data export to the specified storage device check box.

The automatic data record function is used to save the test result data to the internal HDD automatically. This function can be disabled if the automatic data export function is enabled. To disable the automatic data record function, remove the check from the Enable automatic data record to the internal storage device check box.

Even if both data export and data record functions are enabled, the functions can be set to OFF by removing the check from the Record Test Result Data Automatically check box on the Run Option dialog box.

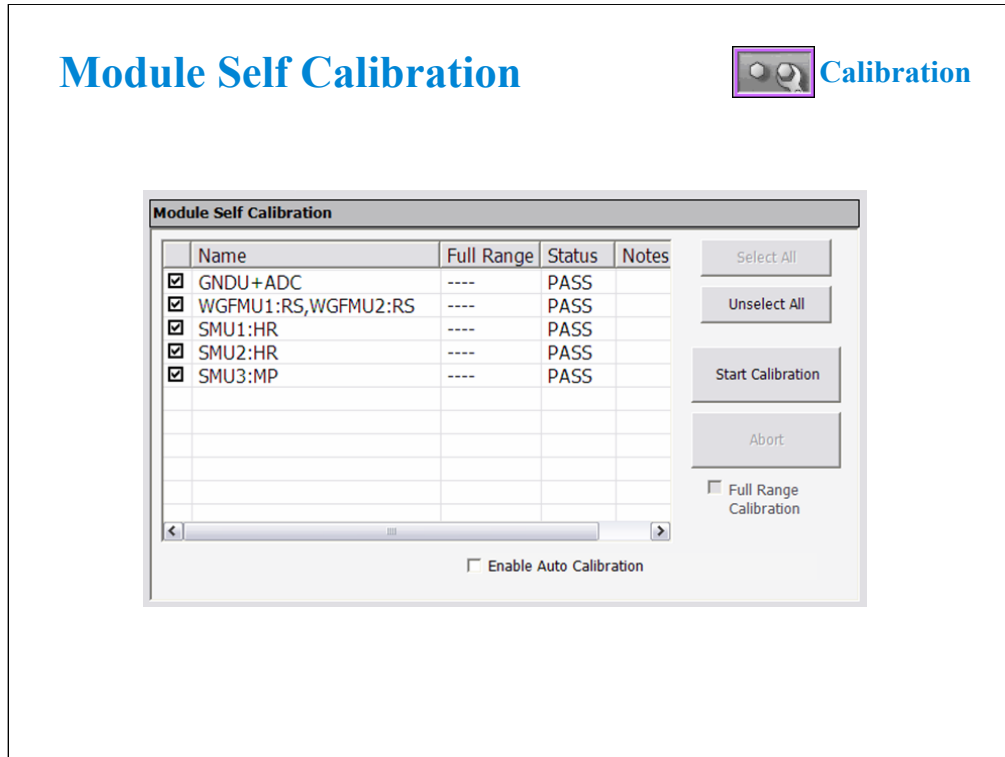

The Calibration window is opened by clicking the Calibration button. The Module Self Calibration screen of this window is used to perform the calibration of SMUs. The list area of this screen lists Name, Full Range, and Status.

Name: Name of module. To select, check the left check box.

Full Range: For the high resolution SMU (HRSMU) connected to the atto sense/switch unit (ASU). Full range calibration on or off.

Status: Calibration status. Pass or fail.

Notes: Error information when calibration failed.

To perform the self-calibration, specify the modules, open the measurement terminals of the corresponding modules, and click the Start Calibration button.

Full Range Calibration:

For the HRSMU connected to the ASU. Enables or disables the full range calibration. If this box has been unchecked, the B1500A does not use the 1 pA range.

Enable Auto Calibration:

Enables or disables the auto-calibration capability. If this box has been checked (function ON), and the B1500A/B1505A automatically starts calibration for all modules every 30 minutes if the output switches of all modules are off for 30 minutes.

NOTE:

To perform calibration correctly, open the measurement terminals. If auto-calibration is enabled, do not forget to open the measurement terminals or disconnect the device under test from the terminals after measurement.

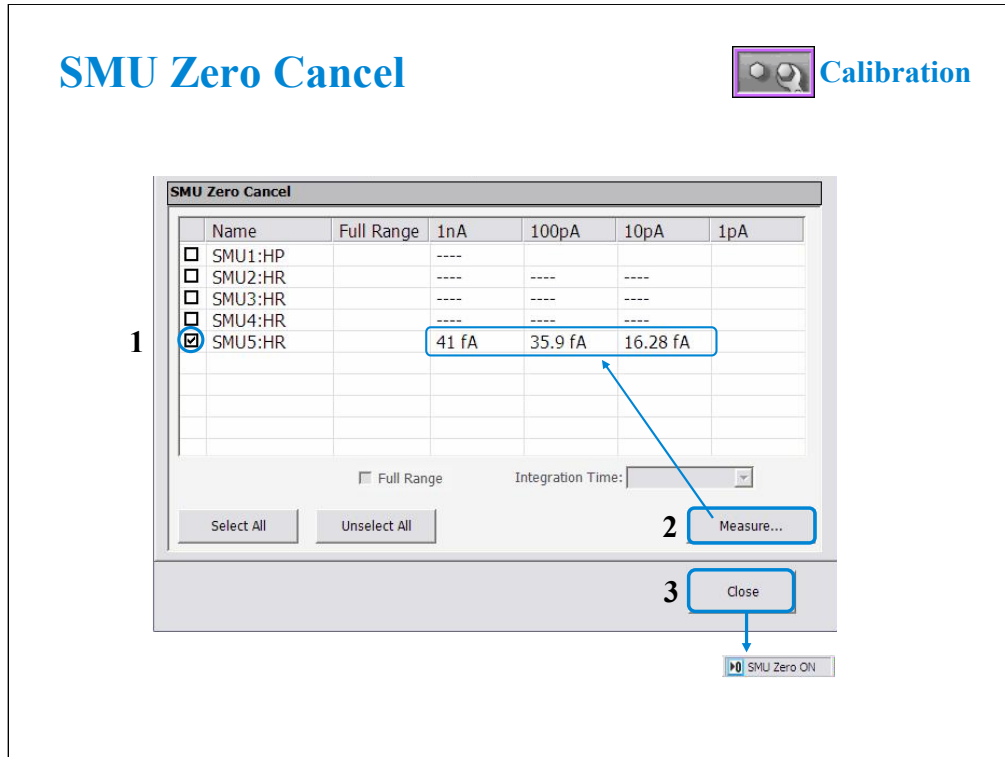

The SMU Zero Cancel screen is used to perform the SMU zero offset current measurement and set the SMU zero offset cancel function.

This function subtracts the offset current from the current measurement raw data, and returns the result as the measurement data. This function is used to compensate the error factor (offset current) caused by the measurement path such as the measurement cables, manipulators, or probe card.

To enable this function, perform the following procedure.

1. Check the left box of the Name column to specify the module to enable this function.
2. Click the Measure... button to perform the zero offset current measurement and wait until the measurement is completed. The measurement data will be displayed in the appropriate cell.
3. Click the Close button to enable the zero offset cancel function.

To disable the function, uncheck the left box of the Name column, and click the Close button.

Note:

The offset cancel is not available for measurement over 100 nA range. For 10 nA range measurement, the offset cancel is performed by using the 1 nA range offset value. For measurement by a range less than 10 nA, the offset value measured by each range is used.

For more information, see online help or User's Guide.

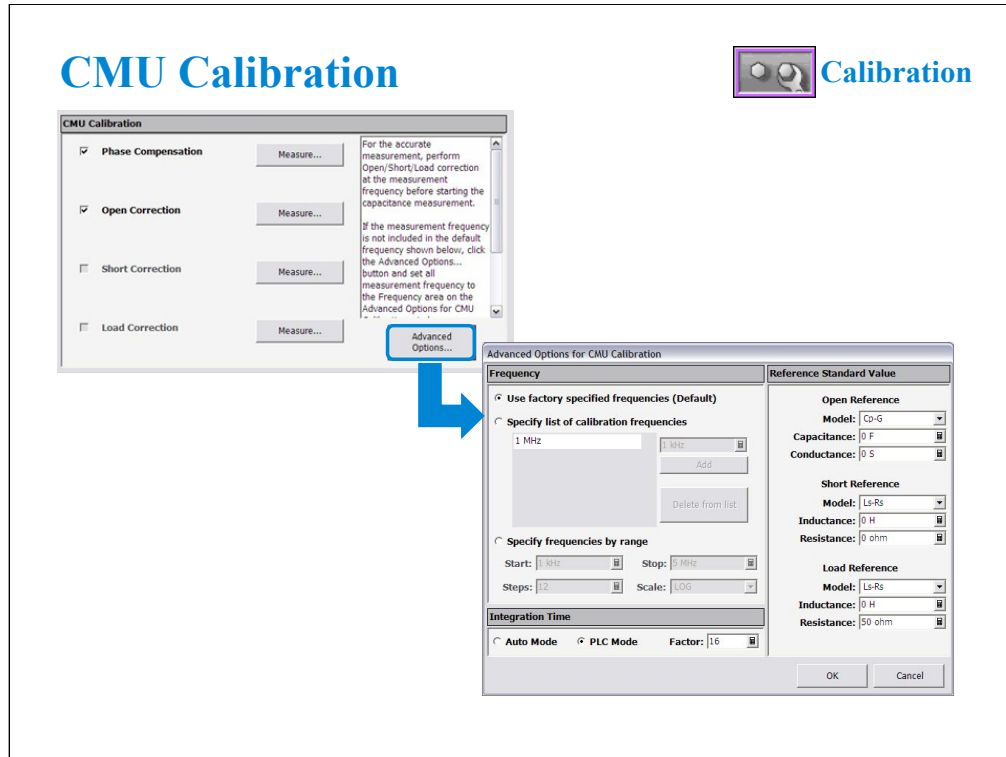

The CMU Calibration screen is used to perform the measurement data correction of the multi frequency capacitance measurement unit (MFCMU). For the easy way, perform the phase compensation and the open correction at least. The check boxes left of the Open/Short/Load Correction and the Phase Compensation are effective after the corresponding measurement is performed.

Measure...: Opens a dialog box used to perform correction/compensation data measurement. To perform the measurement, follow the dialog box.

Advanced Options...: Opens the “Advanced Options for CMU Calibration” dialog box used to set the frequencies for the correction data measurement and the reference values of the working standard. See the next page.

To perform the open correction and the phase compensation, open the measurement terminals.

To perform the short correction, connect the measurement terminals together.

To perform the load correction, connect your load standard between the high terminal and the low terminal.

NOTE:

For a more accurate measurement, perform Open/Short/Load correction at the measurement frequency before starting the capacitance measurement.

If the measurement frequency is not included in the list of default frequencies below, click the Advanced Options... button and set the measurement frequency on the Frequency area of the Advanced Options for CMU Calibration window.

Default frequencies:

1 k, 2 k, 5 k, 10 k, 20 k, 50 k, 100 k, 200 k, 500 k, 1 M, 1.2 M, 1.5 M, 2 M, 2.5 M, 2.7 M, 3 M, 3.2 M, 3.5 M, 3.7 M, 4 M, 4.2 M, 4.5 M, 5 MHz

Advanced Options for CMU Calibration

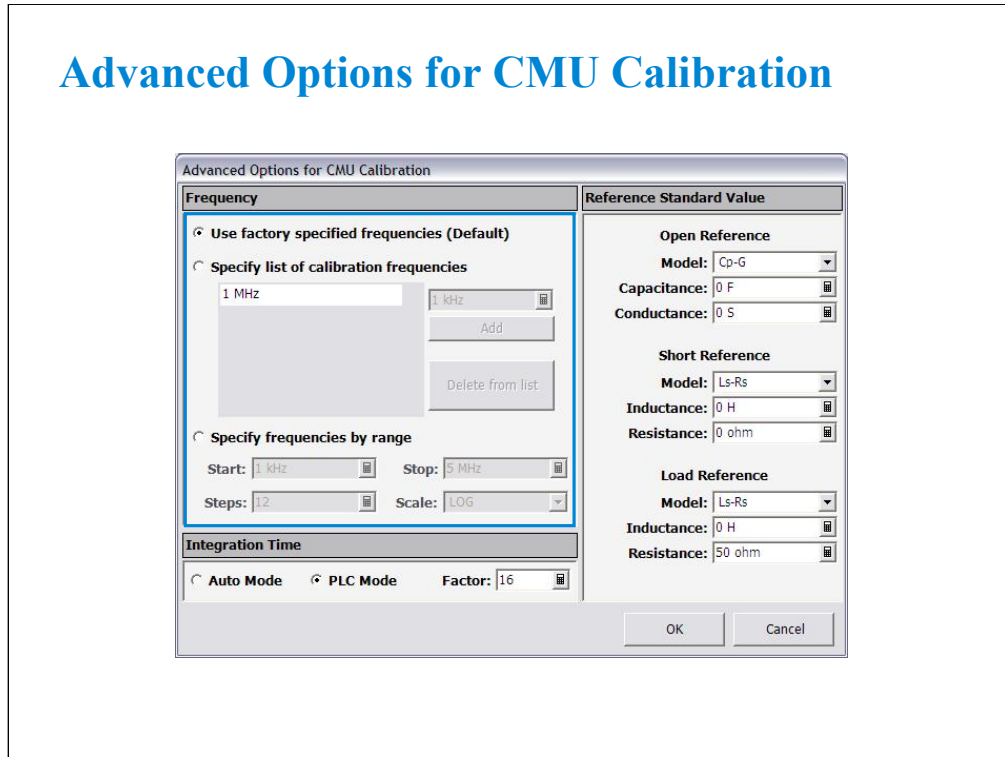

This dialog box is opened by clicking the Advanced Options... button, and is used to set the information required to measure the open/short/load correction data and the phase compensation data. This dialog box provides the following action button.

OK: Applies the setup changes and closes this dialog box.

Cancel: Cancel the setup changes and closes this dialog box.

Frequency: You can select the measurement frequency setup mode from the following modes.

Measurement frequency setup modes:

Default (Use factory specified frequencies): Usually, select this mode. 23 points are automatically set. They are 1 k, 2 k, 5 k, 10 k, 20 k, 50 k, 100 k, 200 k, 500 k, 1 M, 1.2 M, 1.5 M, 2 M, 2.5 M, 2.7 M, 3 M, 3.2 M, 3.5 M, 3.7 M, 4 M, 4.2 M, 4.5 M, and 5 MHz.

Specifies by list: Select this mode when you want to set the frequencies independently. The frequency must be 1 kHz to 5 MHz. The number of frequencies must be 1 to 101. Click Add to open a dialog box, and enter the value. For the unnecessary value, highlight the value and click Delete.

Specifies by range: Select this mode when you want to set the frequencies sequentially and automatically. Specify the start frequency, the stop frequency, the number of steps, and the scale LINEAR/LOG. The start frequency must be less than the Stop value and at least 1 kHz. The stop frequency must be more than the Start value and no more than 5 MHz. The number of steps must be 2 to 1001.

NOTE:

If the device measurement frequency is not equal to the correction data measurement frequency, calculation will be performed automatically to get the correction data for the device measurement frequency, and the calculated correction data will be used for the data correction of the measurement data.

Advanced Options for CMU Calibration

Advanced Options for CMU Calibration

Frequency

Use factory specified frequencies (Default)

Specify list of calibration frequencies

1 MHz 1 kHz [X]

Add

Delete from list

Specify frequencies by range

Start: 1 kHz Stop: 5 MHz

Steps: 12 Scale: LOG

Reference Standard Value

Open Reference

Model: Cp-G

Capacitance: 0 F

Conductance: 0 S

Short Reference

Model: Ls-Rs

Inductance: 0 H

Resistance: 0 ohm

Load Reference

Model: Ls-Rs

Inductance: 0 H

Resistance: 50 ohm

Integration Time

Auto Mode PLC Mode Factor: 16

OK Cancel

Integration Time area defines the integration time used for measuring phase compensation data or open/short/load correction data. The number of averaging samples (Mode=AUTO) or the averaging time (Mode=PLC) is set.

Mode: A/D converter operation mode, AUTO or PLC.

Factor: Factor for the initial value. For details, see online help or user's guide.

Advanced Options for CMU Calibration

Advanced Options for CMU Calibration

Frequency

Use factory specified frequencies (Default)

Specify list of calibration frequencies

1 MHz 1 kHz Add

Delete from list

Specify frequencies by range

Start: 1 kHz Stop: 5 MHz

Steps: 12 Scale: LOG

Integration Time

Auto Mode PLC Mode Factor: 16

Reference Standard Value

Open Reference

Model: Cp-G

Capacitance: 0 F

Conductance: 0 S

Short Reference

Model: Ls-Rs

Inductance: 0 H

Resistance: 0 ohm

Load Reference

Model: Ls-Rs

Inductance: 0 H

Resistance: 50 ohm

OK Cancel

Reference Standard Values area provides the following entry fields used to set the reference values of the open/short/load standard. If you use the standard, enter the reference values to the entry fields. OPEN Reference: Capacitance and Conductance. If you do not use the reference, enter 0 in the both fields.

SHORT Reference: Inductance and Resistance. If you do not use the reference, enter 0 in the both fields.

LOAD Reference: Inductance and Resistance

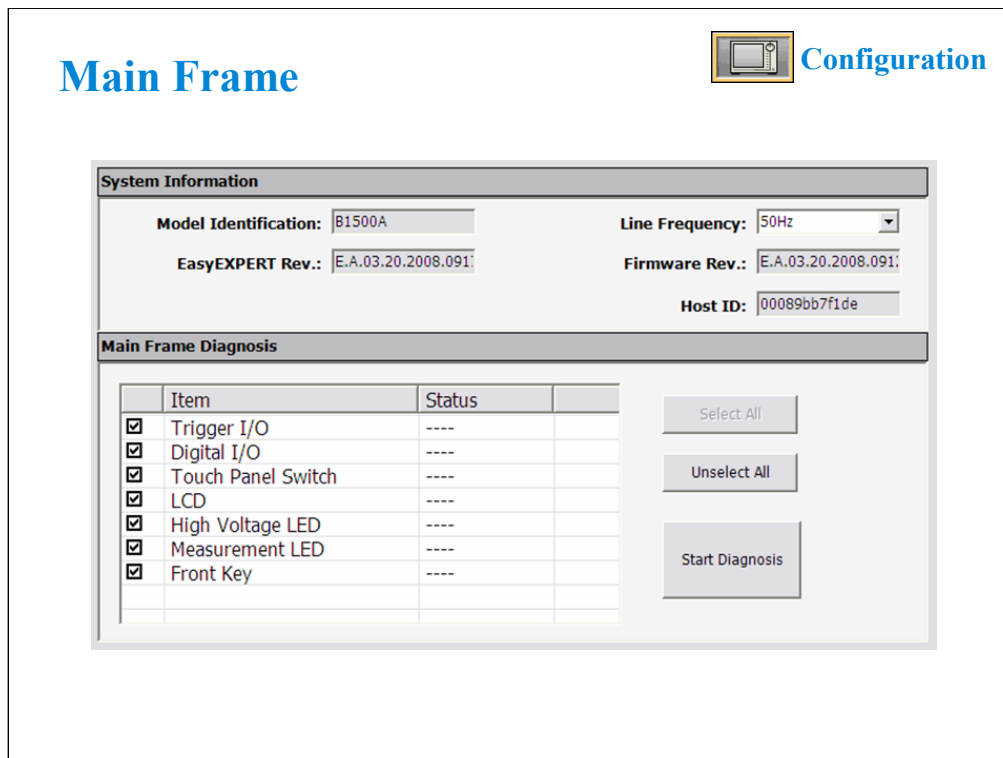

The Configuration window is opened by clicking the Configuration button, and is used to display the system information and event log, as well as to perform diagnostics and self-test.

The Main Frame screen is used to display the system information and perform diagnostics.

Model Identification: Displays the instrument ID. B1500A or B1505A.

Line Frequency: Sets the power line frequency, 50 Hz or 60 Hz.

EasyEXPERT Rev.: Displays the revision number of the EasyEXPERT.

Firmware Rev.: Displays the revision number of the B1500A/B1505A firmware.

Host ID: Displays the host id of the B1500A/B1505A internal computer.

Main Frame Diagnosis: This area lists Item and Status.

Item: Name of diagnostics item. To select, check the left check box.

Status: Diagnostics status. Pass or fail.

To perform diagnostics, specify the items to perform and click the Start Diagnosis button. A dialog box is opened. Follow the dialog box to perform the diagnostics. Some items need your judgement, pass or fail. Also you will need to connect an adapter, press keys, check LEDs, and so on.

The Host ID is important for the B1540A-002 users and the B1541A-002 users. It is necessary to activate the EasyEXPERT or Desktop EasyEXPERT Software Plus features. For details, see the Software Entitlement Certificate.

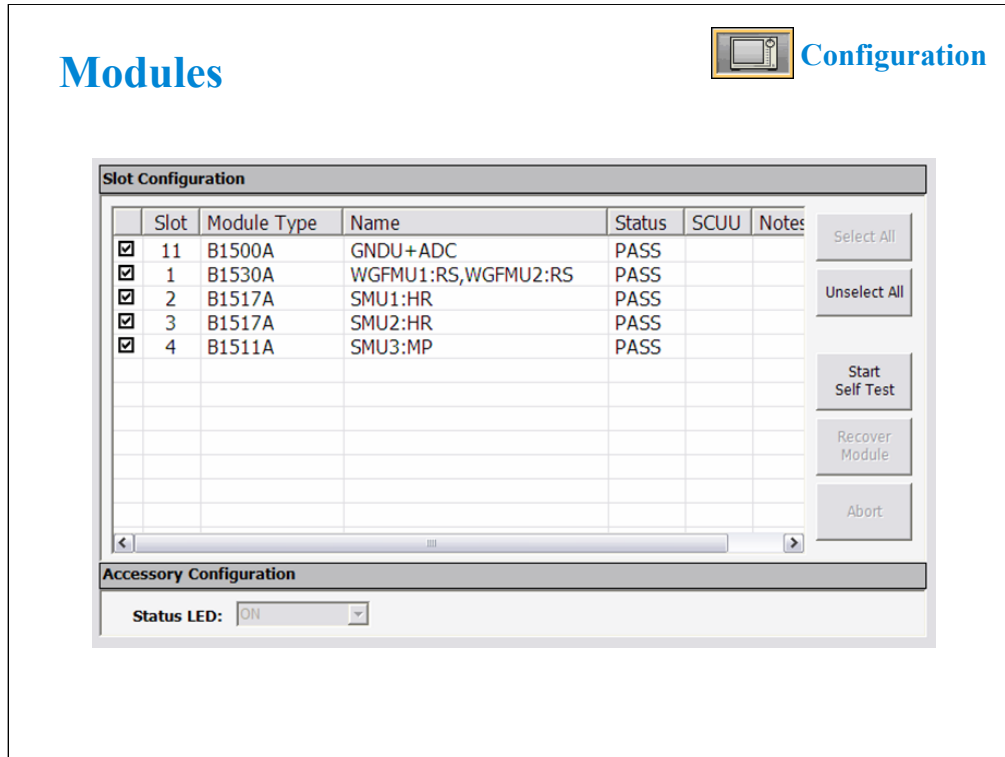

The Modules screen is used to perform self-test of modules.

Slot: Slot number where the module is installed. To select, check the left check box.

Module Type: Module model number

Name: Module name

Status: Self-test status, Passed, Failed, Recovered, or ---- (self-test has not been performed)

SCUU: Specifies if the module is connected to the SCUU.

Notes: Error information when the module self-test failed.

To perform self-test, specify the modules, open the measurement terminals of the corresponding modules, and click the Start Self Test button.

Recover Module button is for the service use only. This button makes the failed modules respond again. This button does not solve the problem that causes the Failed status.

Status LED: Enables (ON) or disables (OFF) the status indicator (LED) of the ASU (Atto Sense and Switch Unit) and the SCUU (SMU CMU Unify Unit).

ASU – B1500A

 **Configuration**

ASU List

Slot	Module Type	Name	ASU Serial Number	ASU I/O Path
1	B1510A	SMU1:HP		
3	B1510A	SMU2:HP		
5	B1517A/E5288A	SMU3:HR/AS	JP10M00172	SMU
6	B1517A/E5288A	SMU4:HR/AS	JP10M00300	SMU
7	B1517A	SMU5:HR		
8	B1511A	SMU6:MP		
9	B1511A	SMU7:MP		
10	B1520A	CMU1:MF		

* NOTE: The specifications are satisfied and guaranteed for the exclusive combination of the ASU and the HRSMU. So confirm the serial number of the ASU and connect it to the dedicated HRSMU properly.

ASU I/O Path:

Only for the B1500A. This screen is available if the B1500A installs the HRSMU connected to the ASU (Atto Sense/Switch Unit), and shows the ASU information.

Slot: Slot number

Module Type: Type of module

Name: Module name or SMU name

ASU Serial Number: Serial number of the ASU registered as a pair with the HRSMU. This cell displays an error message instead of the serial number if unpaired ASU is connected.

ASU I/O Path: ASU input to output connection, SMU or AUX

If the ASU I/O Path field is set to SMU, the ASU makes the path from the ASU Force input to the ASU output.

If the ASU I/O Path field is set to AUX, the ASU performs automatic switching in every test. The ASU makes the path from the AUX In input to the ASU output for the test without the HRSMU and makes the path from the ASU Force input to the ASU output for the test with the HRSMU.

Only for the B1500A. This screen is used to establish the GPIB connection with Agilent B2200A/B2201A/E5250A switching matrix and define the B2200A/B2201A/E5250A input port connections.

Switching Matrix Type: Displays the type of the switching matrix or No Switching Matrix.

GPIB Address: Specifies the GPIB address of the switching matrix. 1 to 30.

Poll: Confirms if the switching matrix of the specified GPIB address is connected to the B1500A.

Start Self Test: Starts the selftest of the switching matrix.

SWM IN#: Switching matrix input ports. Enter the label used to specify the input port to the right entry field. The port name and the connected module name can be the label. The character : (colon) cannot be used. Checking the Kelvin check box grays out the coupled even number port. Checking the CMU check box grays out SWM IN10 for the E5250A or SWM IN14 for the B2200A/B2201A. The input ports IN11 to IN14 are not available for the E5250A.

Kelvin: Check this box if this port is used for the Kelvin connection.

CMU: To perform capacitance measurement through the switching matrix, check this check box and set CMU1:MF to the SWM IN9 for the E5250A or the SWM IN13 for the B2200A/B2201A. And connect MFCMU to the Input 9 and 10 of the E5250A or the Input 13 and 14 of the B2200A/B2201A. To perform capacitance compensation, see User's Guide.

Extended Configuration: Opens the Extended Configuration dialog box. See the next page.

Note: Standard revision of EasyEXPERT does not support the E5250. The E5250 control is a feature of the B1540A-002/B1541A-002.

Note: The E5255A installed in the E5250A is not supported.

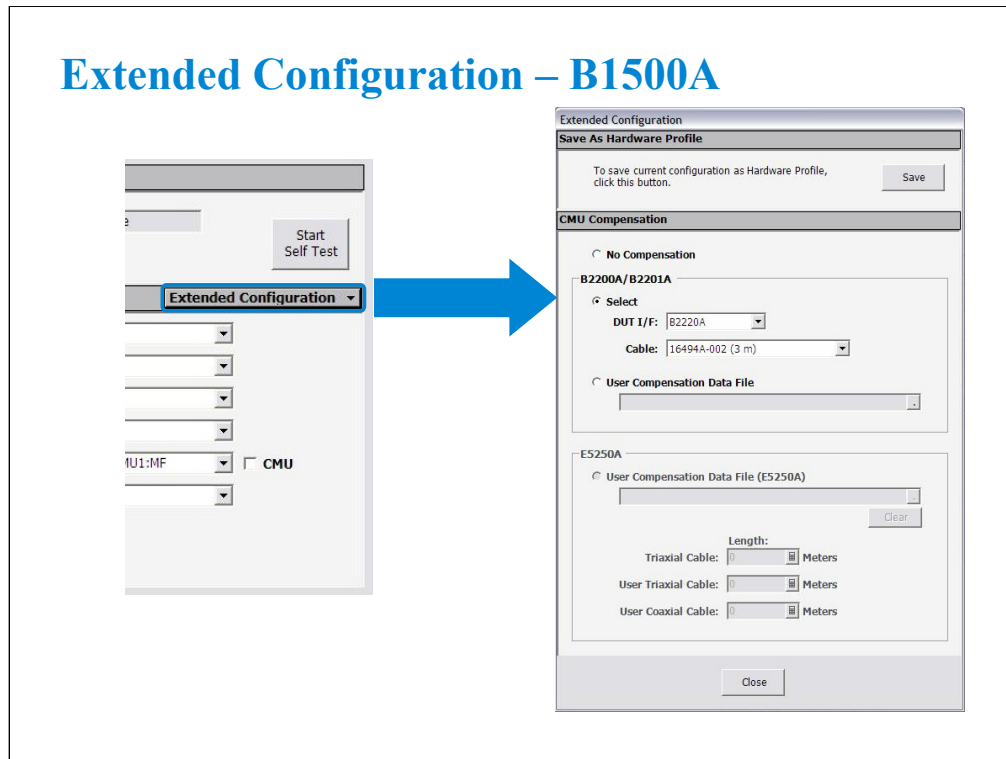

This dialog box is opened by clicking the Extended Configuration button in the Configuration window Switching Matrix screen.

Save as Hardware Profile is used to save the hardware profile that is the B2200A/B2201A/E5250A hardware configuration and the measurement module connection. Click the Save button to save the present hardware profile. The hardware profile can be made for each workspace individually.

CMU Compensation is used to select the compensation mode of the capacitance measurement using the B2200A/B2201A/E5250A. Click one of the radio buttons, No Compensation, Select, and User Compensation Data File. For the capacitance compensation, see User's Guide.

- No Compensation:

Select this radio button if you do not need the capacitance compensation. The raw data without compensation is displayed and saved.

- Select:

Select this radio button to perform the capacitance compensation for the path from the B2200A/B2201A input ports to Agilent 16495F/G connector plate or Agilent B2220A probe card interface. The data after compensation is displayed and saved.

DUT I/F field is used to specify the model number of the path you use. The selections are the 16495F/G and B2220A.

Cable field is used to specify the model number of the cable from the B2200A/B2201A output to the DUT I/F. The selections are the 16494A/B/C-001/002/005. This mode cannot perform the capacitance compensation for the cables to positioner/manipulator or the probe card.

- User Compensation Data File:

Select this radio button to perform the capacitance compensation for the path from the B2200A/B2201A/E5250A input ports to the end of positioner/manipulator or probe card. See User's Guide. The data after compensation is displayed and saved.

Note: Standard revision of EasyEXPERT does not support the E5250. The E5250 control is a feature of the B1540A-002/B1541A-002.

Note: The E5255A installed in the E5250A is not supported.

SMU/PG Selector – B1500A

 **Configuration**

16440A SMU/PG Selector

Enable SMU/PG Selector

	SMU Assignment:	Input/Output Path:
Selector CH1:	SMU2:HR	Normally PGU (AUX)
Selector CH2:	SMU3:HR	Always SMU
Selector CH3:	SMU4:HR	Normally PGU (AUX)
Selector CH4:	SMU5:HR	Always SMU

Only for the B1500A. This screen is used to specify the input connection and the channel connection status of the Agilent 16440A SMU/PG selector.

Enable SMU/PG Selector: Check this box to use the selector.

Selector CH1/CH2: Indicates the channels 1 and 2 of the first selector respectively.

Selector CH3/CH4: Indicates the channels 1 and 2 of the second selector respectively.

SMU Assignment: Specifies the SMU connected to the SMU input of the selector channel CH1, CH2, CH3, or CH4.

Input/Output Path: Specifies the connection status of the selector channel CH1, CH2, CH3, or CH4.

Always SMU: Makes the selector channel “SMU on” state.

Normally PGU (AUX): Performs automatic switching in every test. The selector channel normally makes the “PGU on” state and makes the “SMU on” state only for the test which uses the SMU connected to the Input SMU terminal.

The CH1 and CH3 also provides the “PGU open” state which is set by using the Advanced window of the Measurement Setup.

SMU/PG Selector – B1500A

- Easy to switch between SMU and PGU
- Solid state relay

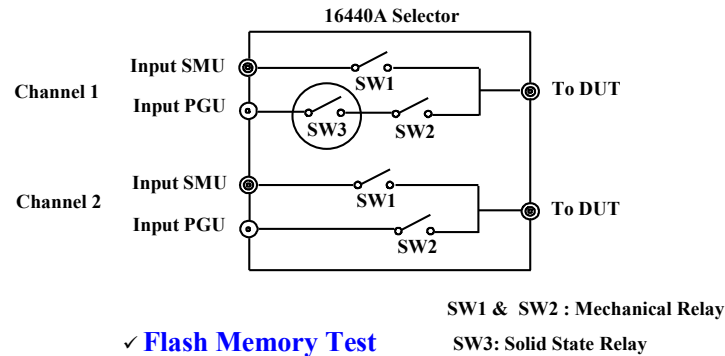

- ✓ Flash Memory Test
- ✓ Transistor photomons

The selector has two channels as shown above. Each channel has two ports (SMU and PGU). External pulse generators can also be connected. The connectors are Triax for SMUs and outputs, and BNC for PGUs.

Up to two selectors (four channels) may be required for some reliability tests such as Flash EEPROM.

As a special design for Flash memory, a solid state relay was added to float the drain. This eliminates wear and tear of millions of closures that would occur with a mechanical relay.

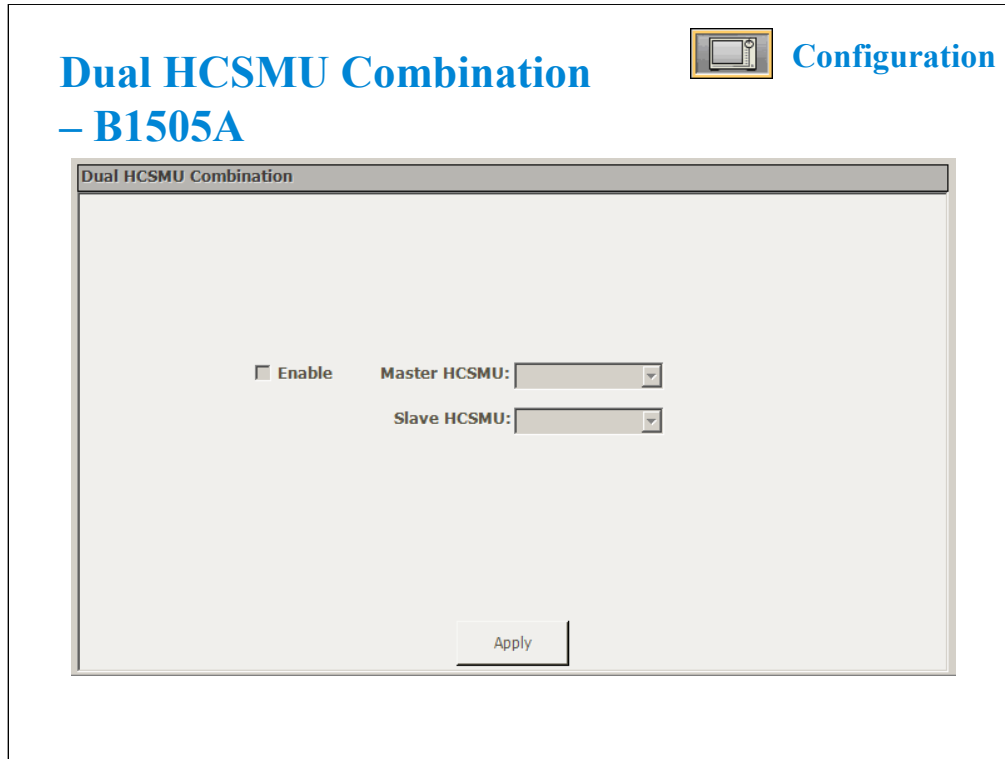

Only for the B1505A. This screen is used to set the dual HCSMU operation.

Enable check box enables/disables the dual HCSMU operation. If this box is checked, the dual HCSMU operation is enabled and two HCSMU modules can be a SMU which supports ± 40 A (pulse), ± 2 A (DC).

Master HCSMU specifies the HCSMU module used as the master channel of the dual HCSMU operation. The module must be connected to the Master port of the 16493S-020/021 dual HCSMU adapter.

Slave HCSMU specifies the HCSMU module used as the slave channel of the dual HCSMU operation. The module must be connected to the Slave port of the 16493S-020/021 dual HCSMU adapter.

Apply button applies the dual HCSMU operating condition. To apply the setup changes successfully, the B1505A must be in the idle state and the Standby output must be OFF.

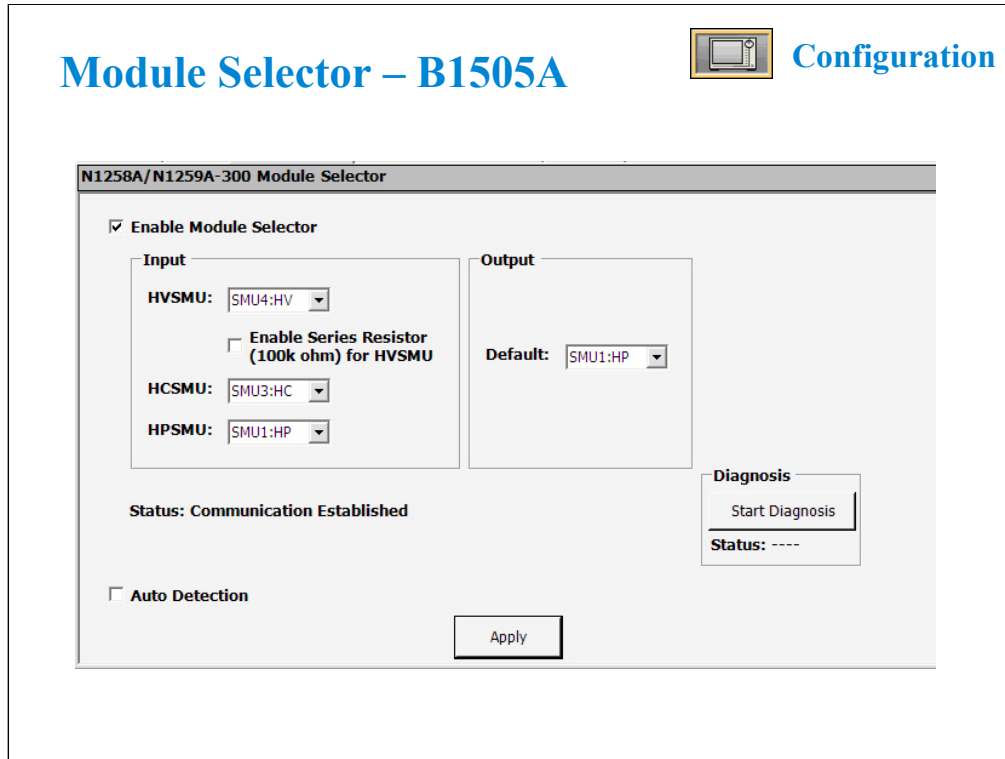

Only for the B1505A. This screen is used to specify the input connection and the default input-output path of the module selector.

Enable Module Selector check box is used to enable/disable the module selector. If this box is checked, the module selector can be used.

Input: Specifies the modules connected to the module selector's HVSMU, HCSMU/DHCSMU, and HPSMU input ports respectively. For the port which no module is connected, blank the entry field. The Enable Series Resistor (100 kohm) for HVSMU check box must be checked if you want to insert the series resistor to the HVSMU path.

Output: The Default field is used to specify the module connected to the module selector output port in the idle state. When a measurement is performed, the module specified by the test setup is automatically connected.

Status: Shows one of the following status.

- Not Detected: Module selector has not been detected yet.
- Communication Established: Normal status. Module selector can be used.
- Communication Lost: Once the module selector was detected. However the communication has been broken now.

Auto Detection check box is used to enable/disable the module selector automatic detection. If this box is checked, the automatic detection of the module selector is performed when EasyEXPERT is launched.

Start Diagnosis button is used to start the module selector diagnosis. And the Status shows the diagnosis result.

Apply button applies the setting.

Module Selector – B1505A

- Easy to switch High open, HPSMU, HCSMU/DHCSMU, HVSMU, or HVSMU via 100 kohm
- Up to 30 A and 3000 V

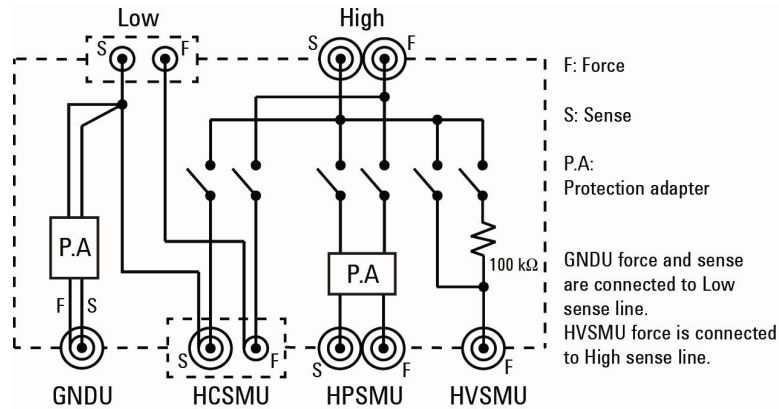

Module selector is used to switch the measurement resource connected to the device under test (DUT) automatically. The measurement resource will be HPSMU, HVSMU, or HCSMU/DHCSMU. One selector provides one switching channel.

The N1258A is used with a DUT interface such as your own test fixture and prober station.

The N1259A with option 300 is for the packaged device test.

CAUTION: If dual HCSMU (DHCSMU) is used with the module selector, the maximum current must be ± 30 A to prevent the module selector from performance degradation and failure.

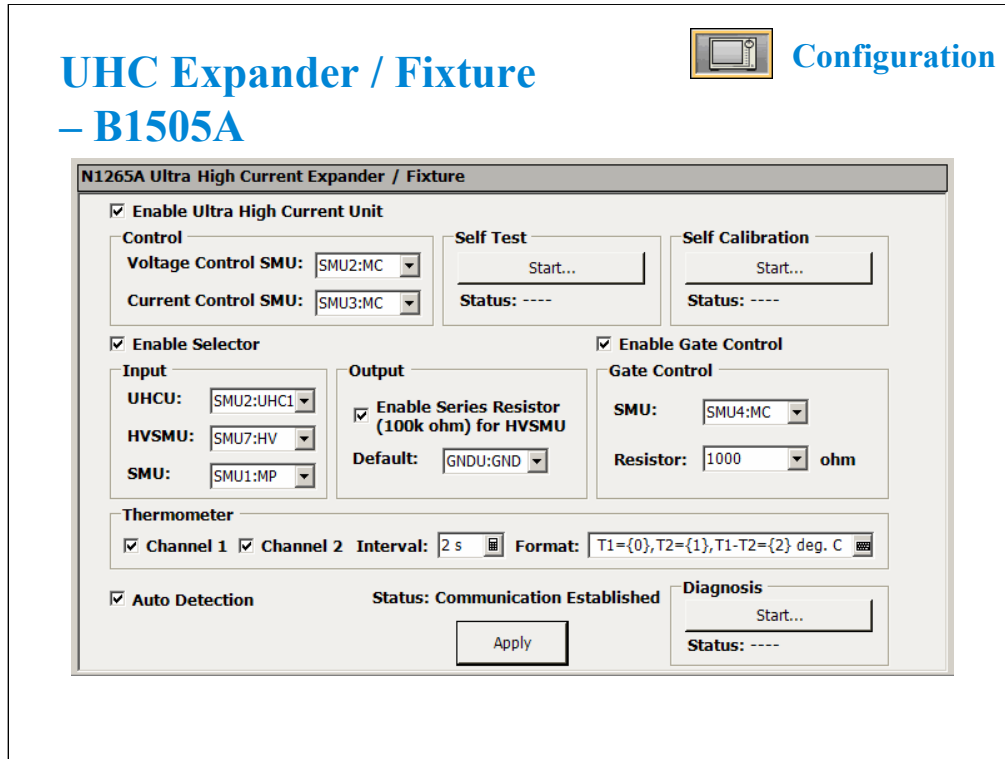

Only for the B1505A. This screen is used to set the N1265A ultra high current expander/fixture. The N1265A can be controlled by the B1505A via the Digital I/O connector.

Enable Ultra High Current Unit enables/disables the ultra high current unit (UHCU). If this box is checked, Control, Self Test, and Self Calibration fields become effective. The UHCU is effective by setting the Voltage Control SMU and the Current Control SMU. The UHCU can be identified by the SMU set to the Voltage Control SMU. In this slide, SMU2 specifies the UHCU.

Enable Selector enables/disables the N1265A built-in selector. If this box is checked, the Input and Output fields become effective. The Input field specifies the UHCU and the measurement resources connected to the selector's HVSMU and SMU inputs. The Output field specifies the Default measurement resource connected to the selector output in the idle state. When a measurement is performed, the measurement resource specified by the test setup is automatically connected. Enable Series Resistor (100 kohm) for HVSMU enables/disables the 100 kohm series resistor on the HVSMU path.

Enable Gate Control enables/disables the Gate path of the N1265A.

Thermometer Channel 1 and Channel 2 enable/disable the thermometer of the N1265A. Interval sets the temperature measurement interval, and Format specifies the format for recording the temperature data. The data is recorded by adding to the end of the Device ID string. Variables {0} for the channel 1 temperature, {1} for the channel 2 temperature, and {2} for the difference between {0} and {1} are available for setting the format.

N1265A UHC Expander / Fixture – B1505A

- SMU path, 3 Kelvin (6 non-Kelvin)
- UHVU path, up to 10 kV
- UHCU path, up to 1.5 kA, through built-in selector
- Gate path
- CMU path through bias tee
- Thermometer, 2 channels

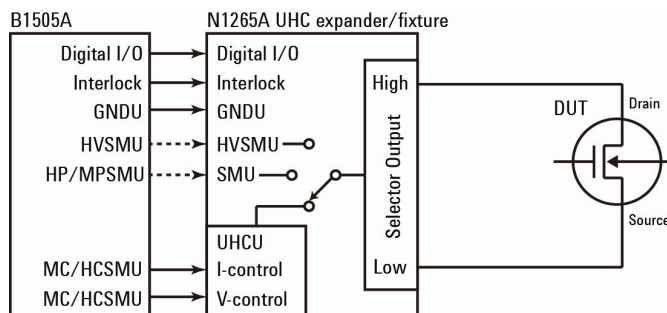

N1265A is a test fixture which contains a ultra high current expander (UHC expander) and a built-in selector.

The fixture provides several paths listed above and the thermometer channels.

The UHC expander configures the ultra high current unit (UHCU) which supports up to 500 A or 1.5 kA with the option N1265A-015. And the output can be connected to the device under test (DUT) through the built-in selector.

The selector output can also be extended to a prober station by using the N1254A-524 prober system cable.

N1265A Built-in Selector – B1505A

- Easy to switch the open condition, GNDU only, UHCU only, or GNDU with SMU, HVSMU, or HVSMU via 100 kohm
- Up to 1.5 kA and 3000 V

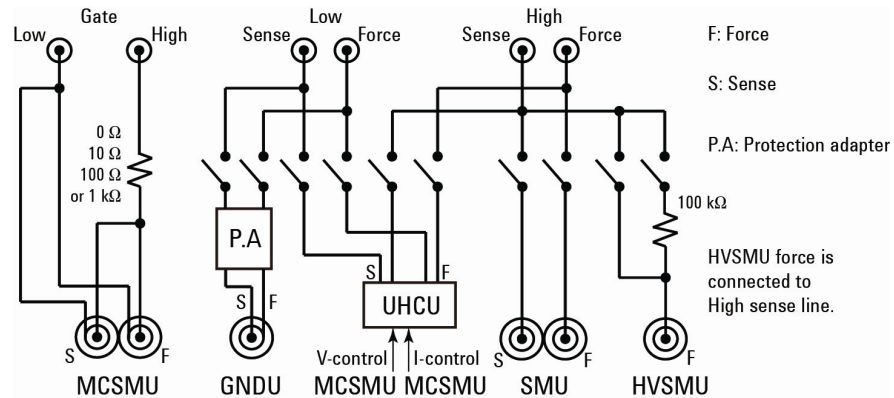

N1265A built-in selector is used to switch the measurement resource connected to the device under test (DUT) automatically. The measurement resource will be UHCU, SMU, or HVSMU. One selector provides one switching channel.

The N1265A also provides the series resistor control for the Gate path. The resistance can be selected from 0, 10, 100, or 1000 ohm.

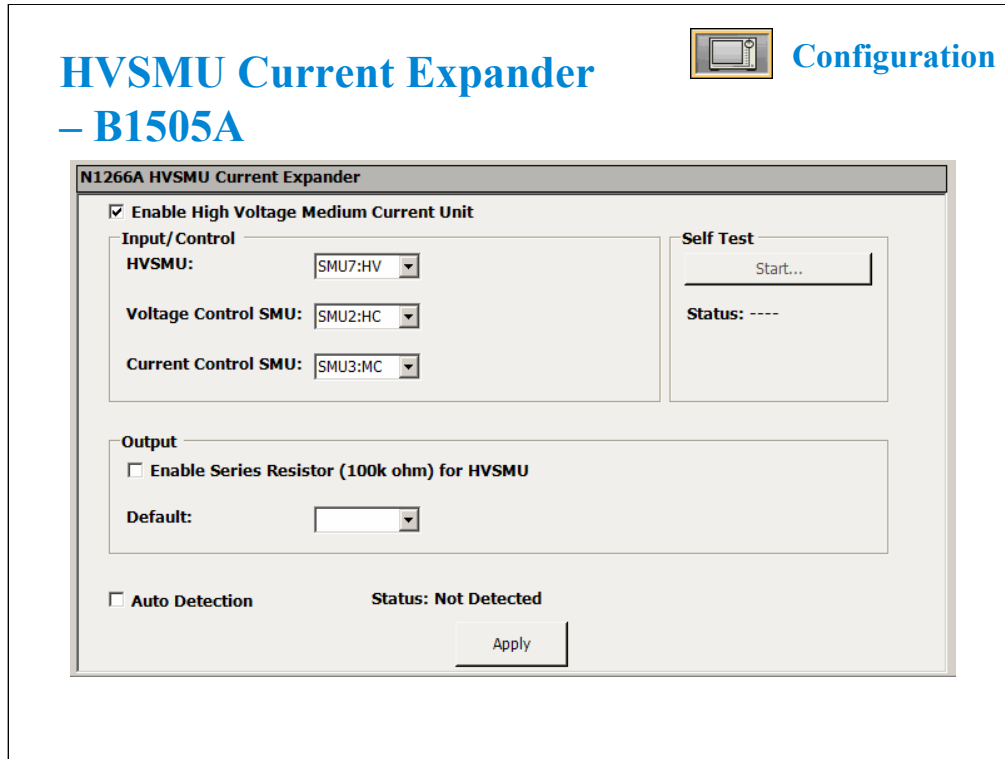

Only for the B1505A. This screen is used to set the N1266A HVSMU current expander. The N1266A can be controlled by the B1505A via the Digital I/O connector.

Enable High Voltage Medium Current Unit enables/disables the high voltage medium current unit (HVMCU). If this box is checked, Input/Control and Output fields become effective. The HVMCU is effective by setting the HVSMU, the Voltage Control SMU, and the Current Control SMU. The HVMCU can be identified by the SMU set to the Voltage Control SMU. In this slide, SMU2 specifies the HVMCU.

N1266A HVSMU Current Expander – B1505A

- Easy to switch High open, HVMCU, HVSMU, or HVSMU via 100 kohm
- Up to 2.5 A and 3000 V

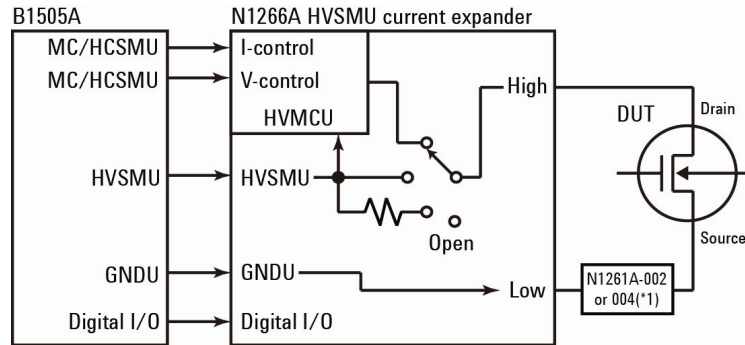

*1: N1261A-002/004 protection adapter is required for connecting prober.
Not required for connecting N1258A, N1259A, N1259A-300, or N1265A.

N1266A is used to expand the HVSMU maximum current up to 2.5 A. The N1266A also provides a built-in selector to switch the measurement resource connected to the device under test (DUT) automatically. The measurement resource will be HVMCU or HVSMU. The GNDU is always connected to the Low output terminal.

The Output field shown in the previous page specifies the Default measurement resource connected to the selector output in the idle state. When a measurement is performed, the measurement resource specified by the test setup is automatically connected. Enable Series Resistor (100 kohm) for HVSMU enables/disables the 100 kohm series resistor on the HVSMU path.

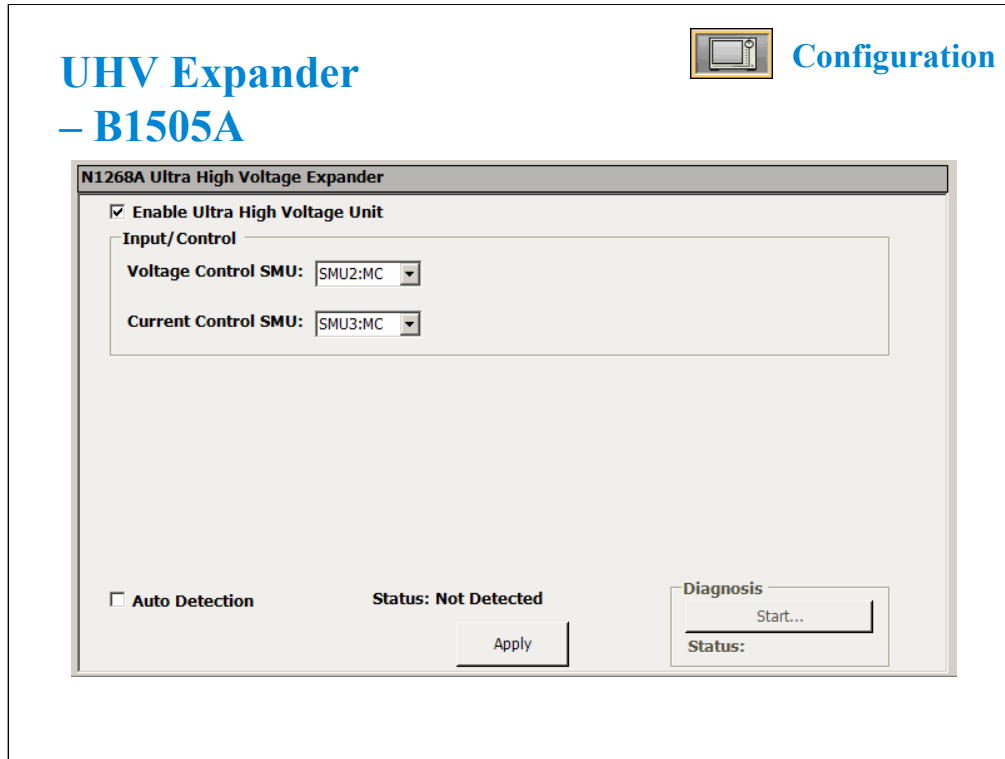

Only for the B1505A. This screen is used to set the N1268A ultra high voltage expander. The N1268A can be controlled by the B1505A via the Digital I/O connector.

Enable Ultra High Voltage Unit enables/disables the ultra high voltage unit (UHVU). If this box is checked, Input/Control field becomes effective. The UHVU is effective by setting the Voltage Control SMU and the Current Control SMU. The UHVU can be identified by the SMU set to the Voltage Control SMU. In this slide, SMU2 specifies the HVMCU.

N1268A UHV Expander – B1505A

- Ultra high voltage up to 10 kV

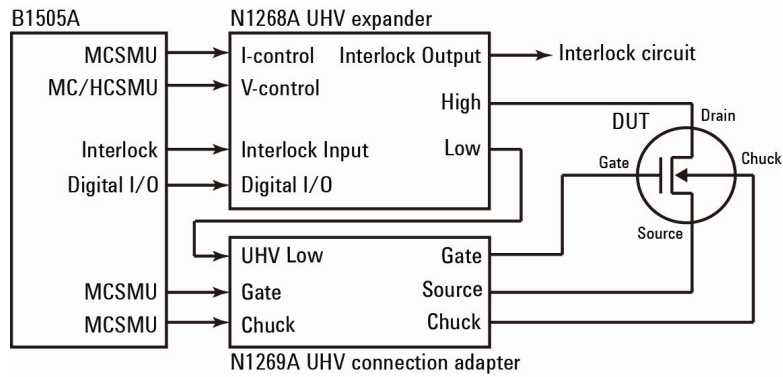

N1268A is used to expand the maximum voltage up to 10 kV.

If you use the N1265A test fixture, connect the UHVU output High and Low to the N1265A UHV High and Low terminals.

If you use a prober station, use the N1269A UHV connection adapter as shown above.

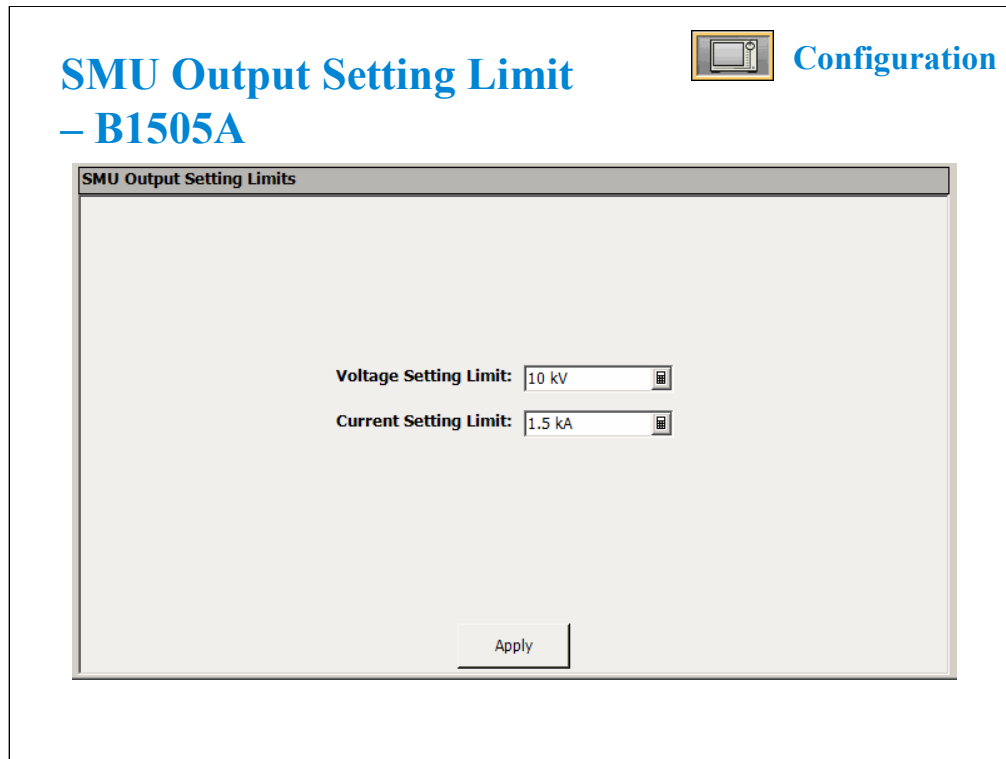

This screen is used to set the upper limit of the SMU output value and compliance value.

Voltage Setting Limit: Sets the upper limit of the voltage output value and compliance value.
Effective value: 200 V to 10 kV, in 100 V step.

Current Setting Limit: Sets the upper limit of the current output value and compliance value.
Effective value: 1 A to 1.5 kA, in 1 A step.

Apply button applies the setting.

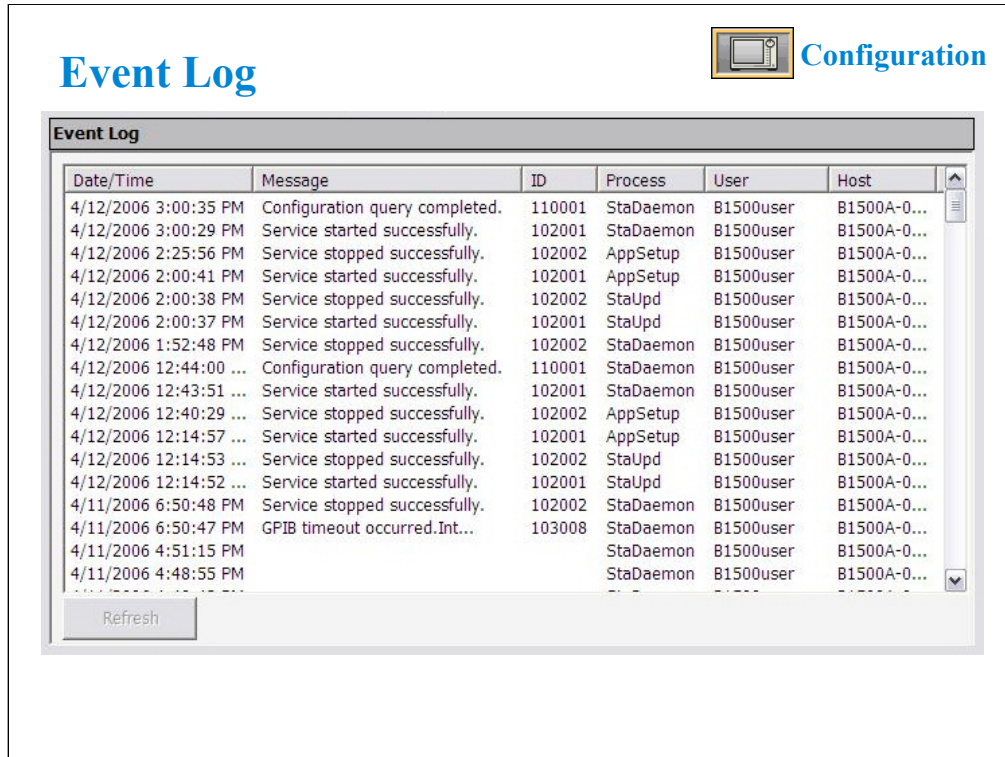

This screen displays the event log.

Date/Time: Displays date and time of the event.

Message: Event message

ID: Process ID of the event

Process: Process name

User: User name. Windows login name.

Host: Host name of the B1500A/B1505A

The Refresh button refreshes the event log.

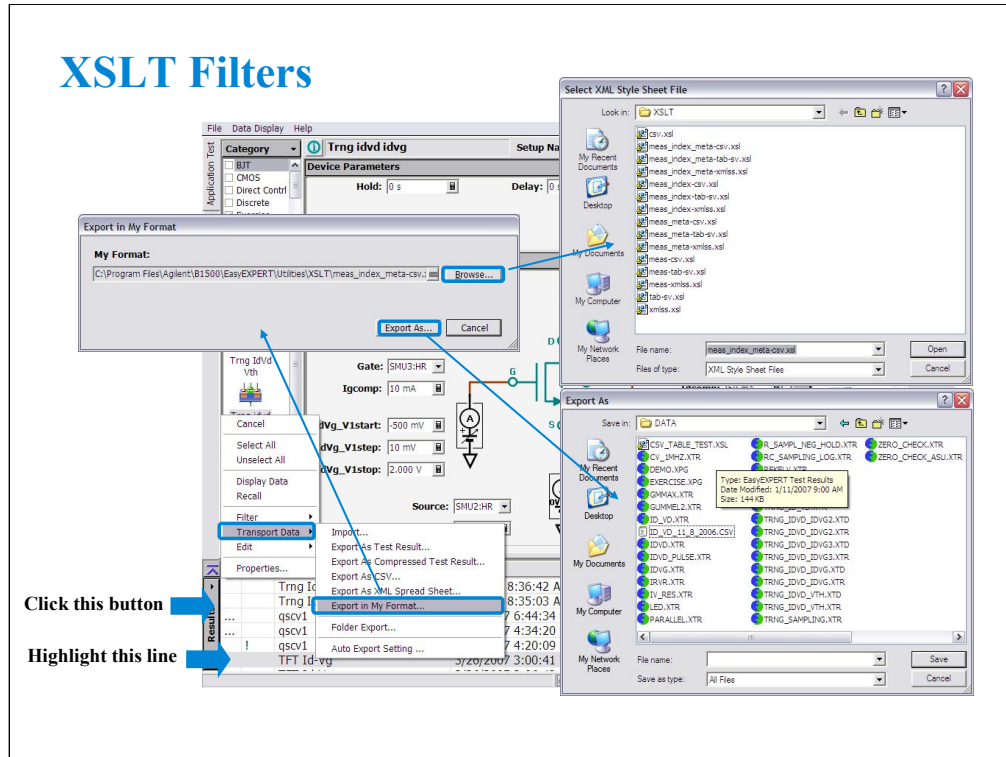

The XSLT (XSL-Transformation, eXtensible Stylesheet Language Transformation) filter files are used to export test records. The fifteen filter files listed below are stored in the C:\Program Files\Agilent\B1500\EasyExpert\Utilities\XSLT folder.

The following filter files are used for exporting the measurement data only.
meas-csv.xml, meas-tab-sv.xml, meas-xmlss.xml

The following filter files are used for exporting the measurement data with the index.
meas-index-csv.xml, meas-index-tab-sv.xml, meas-index-xmlss.xml

The following filter files are used for exporting the measurement data with the meta data.
meas-meta-csv.xml, meas-meta-tab-sv.xml, meas-meta-xmlss.xml

The following filter files are used for exporting the measurement data with the index and the meta data.

meas-index-meta-csv.xml, meas-index-meta-tab-sv.xml, meas-index-meta-xmlss.xml

The following filter files are used for exporting all data including the test setup.
csv.xml, tab-sv.xml, xmlss.xml

Where, the meta data contains the test name, the setup name, the record time of the test results, the device ID, the counter number, the flag of the test results, and the remarks on the test results.

Filter files that contain *xmlss* in the file name export test record in the XML Spread Sheet format.

Filter files that contain *csv* or *tab-sv* in the file name use a comma or a tab for the data separator.

For more information, see online help or User's Guide.



To control external GPIB devices, the B1500A/B1505A must be set to system controller. Exit the EasyEXPERT, and close the Start EasyEXPERT window. After that, launch the Agilent Connection Expert by clicking Start, All Programs, Agilent IO Library Suite, and Agilent connection Expert.

On the Agilent Connection Expert, change the GPIB configuration of the B1500A/B1505A.

- Select GPIB0.
- Click Change Properties... button.
- Change GPIB address to 21 that is the typical address number for the system controller.
- Check System controller box.
- Click OK button.
- Reboot the B1500A/B1505A.

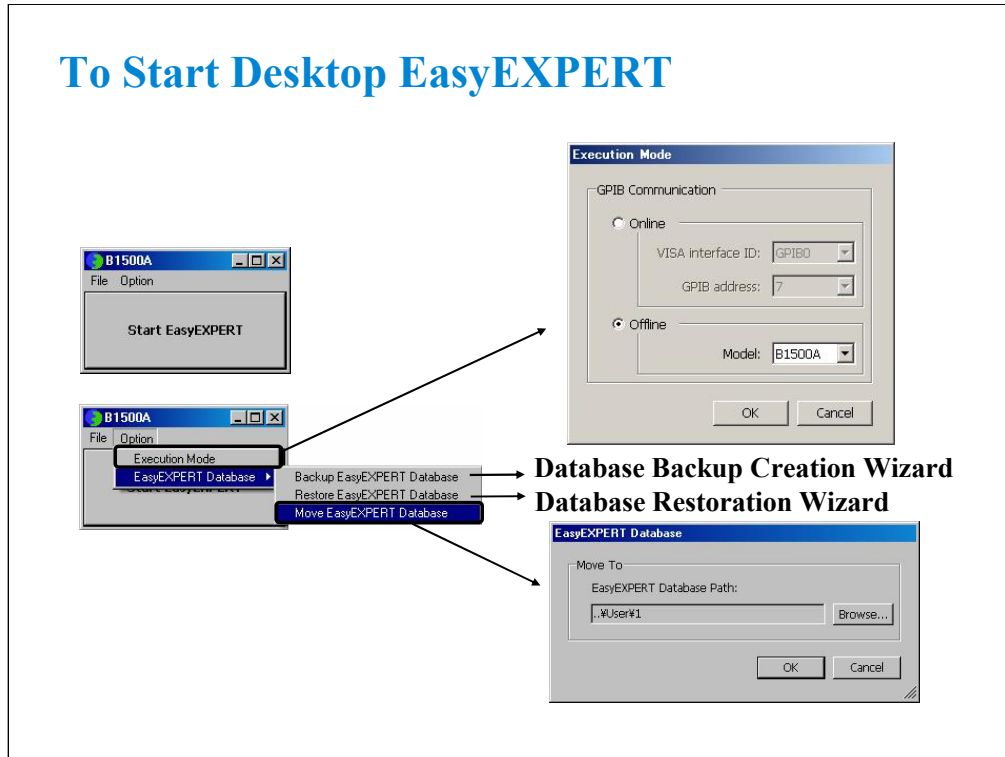

To open the Start EasyEXPERT window, click Start > Programs > Start EasyEXPERT menu. This window provides the Option menu used to open the following dialog box.

Gpib Communication:

Select Online if the B1500A, B1505A, 4155B/C, or 4156B/C is connected to your computer and you want to control it via GPIB. Or else select Offline.

Database Backup Creation Wizard:

Use this wizard to create the EasyEXPERT database backup (xdb file).

Database Restoration Wizard:

Use this wizard to restore the EasyEXPERT database backup. The wizard can restore the xdb file or the backup which is a copy of the folder that contains the EasyEXPERT database.

EasyEXPERT Database:

Specify the EasyEXPERT Database path if you want to move the database to the other folder.

To launch Desktop EasyEXPERT, click the Start EasyEXPERT button.

Note: Desktop EasyEXPERT supports most of the EasyEXPERT functions. However, some functions are not supported on an external computers due to differences in hardware and so on.

Note: For the installation procedure, see the readme file stored in the Desktop EasyEXPERT CD-ROM.

Note: For the offline mode. To use the same module configuration as the B1500A/B1505A, copy the UnitConfigB1500A.xml/UnitConfigB1505A.xml file to your PC which the Desktop EasyEXPERT runs. The file is stored in the B1500A/B1505A hard disk drive. For details, see “To Install Desktop EasyEXPERT” in Agilent B1540A User’s Guide or Online Help.

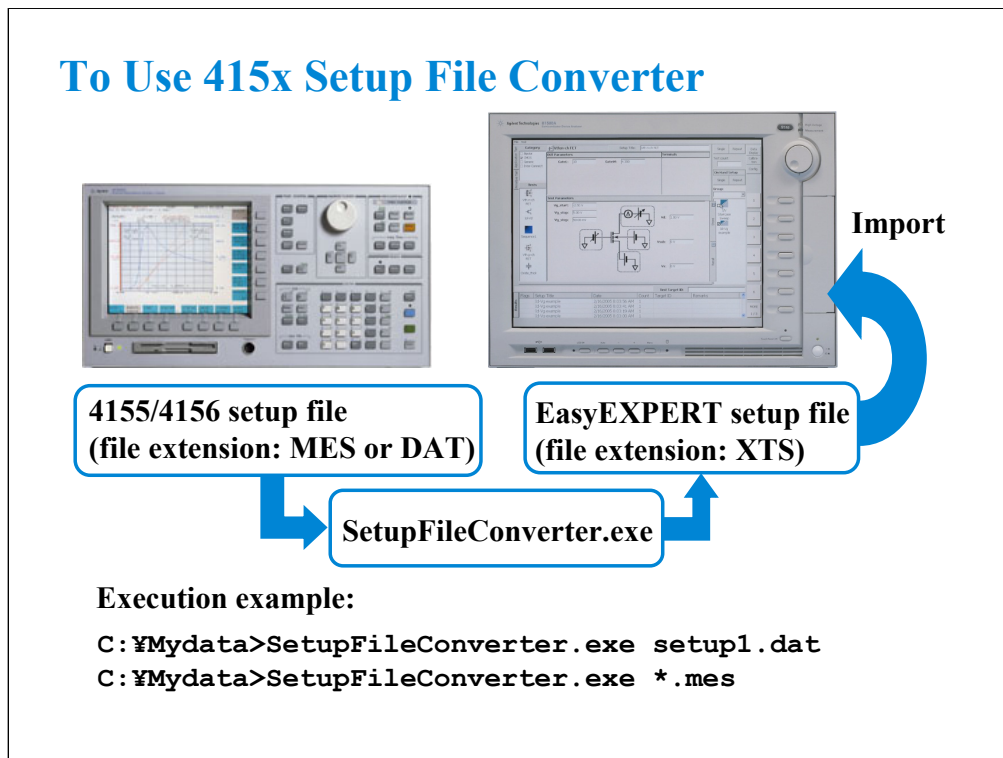

You can reuse the 4155/4156 setup file (MES file or DAT file) for the test using EasyEXPERT. This is realized by Setup File Converter which has the function to create the XTS file by converting the MES or DAT file to the EasyEXPERT format. This executable file is stored in the following folder.

C:¥Program Files¥Agilent¥B1500¥EasyEXPERT¥Utilities

You can execute the setup file converter on the Command Prompt as shown below. If you want to use the Windows desktop instead of the Command Prompt, see the next page.

1. Create your working folder (for example, C:¥415xdata).
2. Copy your MES or DAT files to this folder.
3. Copy SetupFileConverter.exe file to this folder.
4. Launch the Command Prompt.
5. Go to your working folder (for example, C:¥> cd 415xdata).
6. Execute SetupFileConverter.exe as shown in the following example.

```
C:¥415xdata> SetupFileConverter.exe *.MES
```

This example converts all MES files in your working folder to the EasyEXPERT setup file format, and creates the XTS files in this folder.

Note: If you execute the setup file converter without the parameter, the help message will be displayed.

Note: The setup file converter provides some options. See User's Guide or online help for the options.

To Use 415x Setup File Converter

1. Drag and drop the shortcuts of the MES/DAT file on the shortcut of the Setup File Converter.



3. XTS file and shortcut are created.

2. File conversion is executed and system message is displayed.

```
Setup File Converter
SetupFileConverter.exe : Version 0.03.10
Start Conversion : E:\Documents and Settings\AGIL4155.AGILENT\Desktop\RES1.DAT
ExportFile : E:\Documents and Settings\AGIL4155.AGILENT\Desktop\RES1.xts
SetupVersion : HP4155_G02.24
Conversion successfully completed.
----- Press Enter key to quit.
```

You can perform the file conversion on the Windows desktop as follows.

1. Create a shortcut of the SetupFileConverter.exe on the desktop.
2. Copy your MES/DAT files to the desktop.
3. Drag and drop the shortcuts of the MES/DAT files on the shortcut of SetupFileConverter.

This starts the file conversion and displays the system message. And if the conversion is completed successfully, the setup file converter creates the XTS files and the shortcuts on the desktop.

Note: The setup file converter provides some options. See User's Guide or online help for the options.

To Use 415x Setup File Converter

Click [Start] → All Programs → Agilent B1500A EasyEXPERT
→ 4155,4156 Setup File Converter

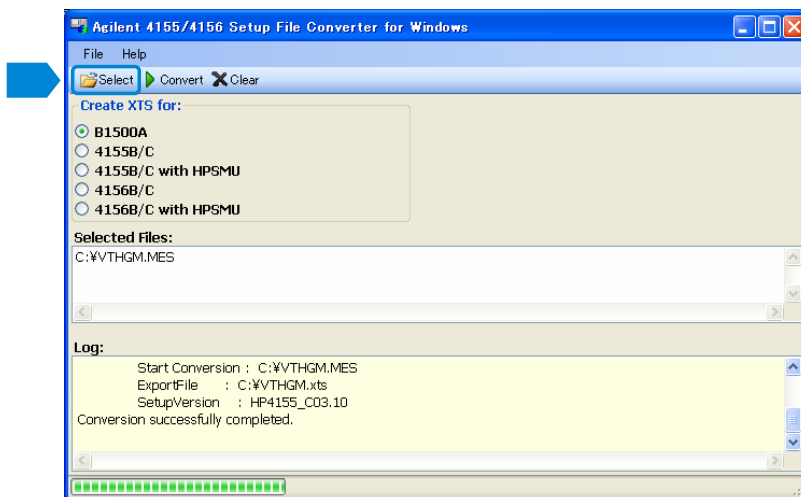

To create XTS file:

The following procedure converts the 4155/4156 setup file (.DAT or .MES) and creates the .XTS file in the folder the setup file is stored.

1. Click Select icon, or click File > Select Files to open the Select 4155/4156 MES Files or DAT Files dialog box.
2. Specify the 4155/4156 setup files to convert. Multiple files can be selected.
3. Click Open on the Select 4155/4156 MES Files or DAT Files dialog box.
4. Click Convert icon, or click File > Convert Files.

To read XTS file, use the import function to read the created .XTS file on the EasyEXPERT.