

Keysight Technologies

LED IV Measurements Using the Keysight B2900A Series of SMUs

Keysight B2901/02/11/12A Precision Source/Measure Unit

Keysight B2901A Precision SMU, 1ch, 100 fA resolution, 210 V, 3A DC/10.5 A pulse

Keysight B2902A Precision SMU, 2ch, 100 fA resolution, 210 V, 3A DC/10.5 A pulse

Keysight B2911A Precision SMU, 1ch, 10 fA resolution, 210 V, 3A DC/10.5 A pulse

Keysight B2912A Precision SMU, 2ch, 10 fA resolution, 210 V, 3A DC/10.5 A pulse



Technical Overview

Introduction

The energy efficiencies and durability of light emitting diodes (LEDs) have led to their increased usage in a variety of applications such as lighting, display panels, etc. This has also spawned research into new types of LEDs with even higher energy efficiencies and properties tailored for specific applications.

The Keysight Technologies, Inc. B2901/02/11/12A Precision Source/Measure Unit is a compact and cost-effective bench-top Source/Measure Unit (SMU) with the capability to output and measure both voltage and current. The B2900A Series of SMUs enables you to make a wide range of current versus voltage (IV) measurements more accurately and quickly than ever before. In addition, the B2900A Series of SMUs comes with an intuitive graphical user interface (GUI) and free PC-based application software that make it easy for you to begin making productive measurements immediately. These features make the B2900A Series of SMUs the best solution for accurate electrical characterization of LEDs.

Figure 1 illustrates the connections necessary to measure the basic IV parameters of an LED using a member of the B2900A Series of SMUs. While this technical overview will focus on IV characterization of LEDs using a single-channel model of the B2900A Series of SMUs, if you need to perform optical tests in addition to electrical tests then a dual-channel models of the B2900A Series of SMUs can be used. The dual-channel models of the B2900A Series of SMUs permit one channel to measure photo diode current and the other channel to drive the LED. This is described in the technical overview, LIV Test of Laser Diode Using the Keysight B2900A Series of SMUs (5990-7115EN).

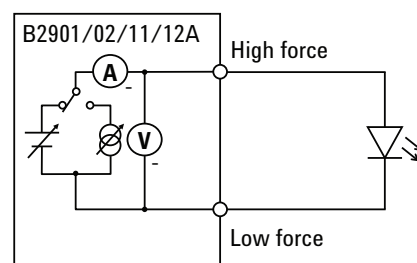

Figure 1. Using the B2900A Series of SMUs to characterize an LED

What is the B2900A Series of SMUs?

An SMU combines the capabilities of a current source, a voltage source, a current meter and a voltage meter along with the capability to switch easily between these various functions into a single instrument. This gives it the ability to evaluate the IV characteristics of devices across all four measurement quadrants without the need for any additional equipment. Besides being able to output and measure voltage or current very accurately, SMUs also possess a compliance feature that allows a limit to be placed on the voltage or current output to prevent device damage. The members of the B2900A Series of SMUs are single or dual channel SMU units that offer a wide range of IV measurement capability for a variety of two-terminal and three-terminal devices. They cover currents from 10 fA to 3 A (DC)/10.5 A (pulse) and voltages from 100 nV to 210 V. In addition to their DC operation mode, the B2900A Series of SMUs also has the ability to perform pulsed measurements in order to prevent device self-heating from distorting the measurement results.

The B2900A Series of SMUs supports 4-wire measurements (remote sensing) to eliminate the voltage error caused by test lead residual resistance. Measurements made through a 2-wire connection can contain significant error when the resistance being measured is comparable to that of the test leads (please see Figure 2a). However, a 4-wire measurement uses one pair of leads to force current and the other pair of leads to monitor voltage. This eliminates cable resistance effects so that only the voltage drop across the DUT is measured (please see Figure 2b). In addition, the 4-wire measurement scheme of the B2900A Series of SMUs keeps the voltage between the sense points (A and B in Figure 2b) at exactly the specified voltage V_{set} , thereby ensuring that your device is characterized exactly under the measurement conditions you specify.

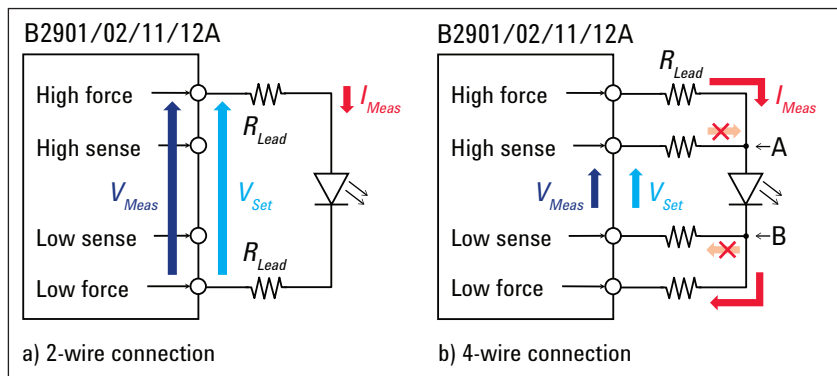

Figure 2. A 4-wire connection eliminates the measurement error caused by residual lead resistance

Quick and easy IV characterization

During routine device evaluation it is often desirable to make a quick measurement from the instrument's front panel without having to go through the time and trouble of writing a test program. To meet this need, all members of the B2900A Series of SMUs have a resident GUI that makes it easy to perform a variety of tests and save measurement data without having to write any code.

The wide QVGA LCD display of the B2900A Series of SMUs supports an easy-to-use GUI that provides easy instrument control from the front panel (please see Figure 3). The GUI of the B2900A Series of SMUs has the following multiple viewing modes: Single View, Dual View, Graph View and Roll View (for viewing time domain measurements). Single View mode allows you to easily set up not only constant voltage and current measurements but also swept voltage and current measurements. Dual View can perform similar functions for both channels simultaneously (for B2902A and B2912A). After measurement completion you can use the front panel GUI to graphically view measurement results such as IV curves using Graph View, and display a list of the measurement data using the Measure Result dialog window.

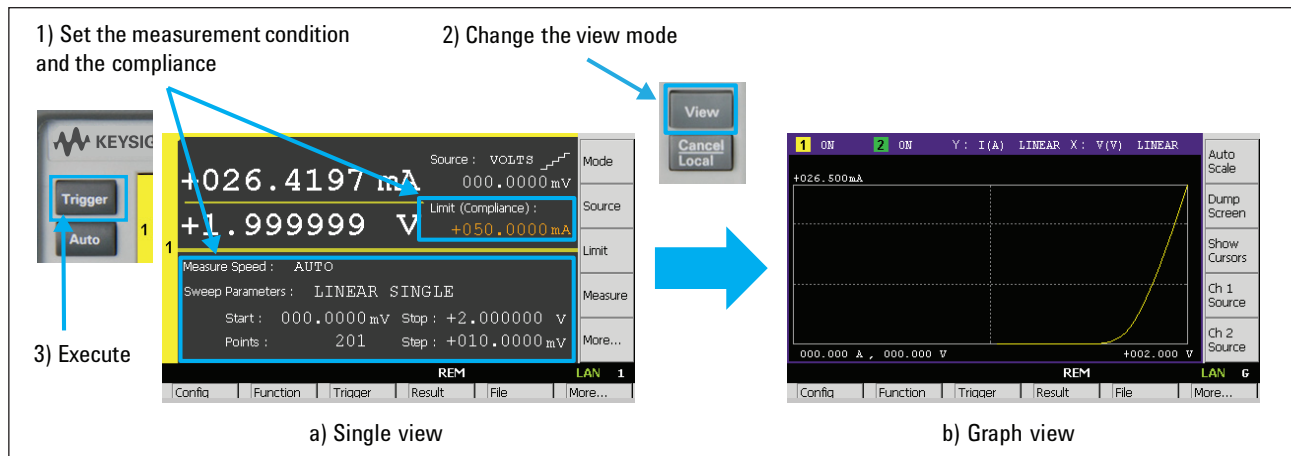

Figure 3. The GUI of the B2900A Series of SMUs makes it easy to take a quick measurement and display the results

The B2900A Series of SMUs has a USB interface on the front panel so that a USB flash memory device can be used with the B2900A Series of SMUs to save and load measurement setups as well as to save measurement results. In addition, Graph View supports a Screen Dump function that enables you to save screen images (such as IV curves) to any attached USB flash memory device as JPEG files, making it easy to include graphical results in reports and presentations (please see Figure 4).

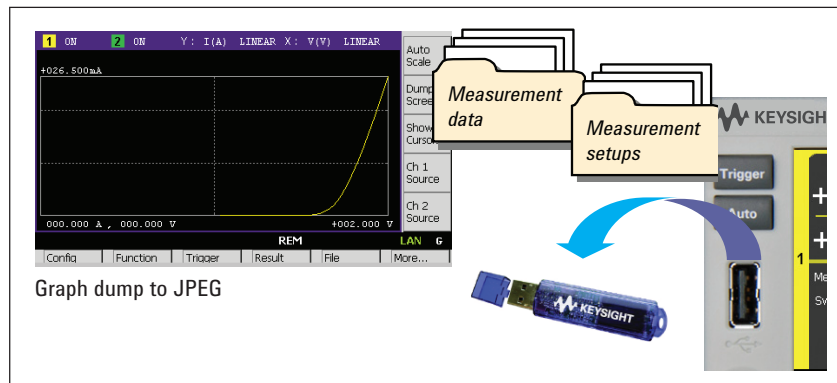

Figure 4. Measurement results and measurement setups can be saved to any attached USB flash memory device

Ready-to-use PC software

In addition to its powerful and easy-to-use GUI, the B2900A Series of SMUs comes with free PC application software to facilitate program development if you prefer PC-based instrument control. The Keysight B2900A Graphical Web Interface and the Keysight B2900A Quick I/V Measurement Software are both available for the B2900A Series of SMUs.

The Keysight B2900A Graphical Web Interface provides functionality to allow access to the B2900A Series of SMUs over a LAN connection. The B2900A Series of SMUs is fully compliant with the LXI class C specification and it contains a web server that provides a webpage with an interface to support the basic measurement functions of the B2900A Series of SMUs. You can quickly and easily make measurements using a standard web browser by just connecting the B2900A Series of SMUs to a PC using a LAN cable.

The Keysight B2900A Quick I/V Measurement Software has more powerful measurement capabilities to control the B2900A Series of SMUs over GPIB, USB or LAN connections (please see Figure 5). You can download this PC-based software from Keysight's web site for free. The Keysight B2900A Quick I/V Measurement Software also supports a variety of functions such as a sweep measurement, a sampling measurement, graphical display functions and the ability to save test results into CSV files.

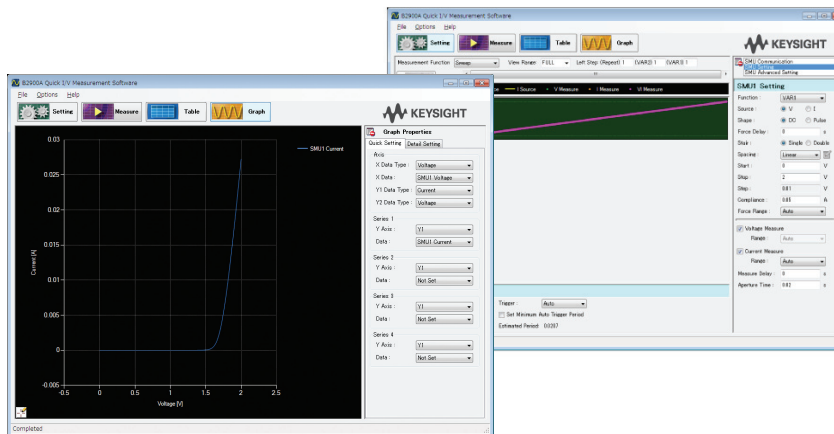

Figure 5. It is easy to make a quick measurement on a PC using the Keysight B2900A Quick I/V Measurement Software

Easy custom program support

If you have specialized programming needs then both Standard Commands for Programmable Instruments (SCPI) and IVI-COM drivers are available for the B2900A Series of SMUs. SCPI is an industry-standard command set for basic instruments, and it has a uniform structure that supports a common set of commands. The SCPI command set for the B2900A Series of SMUs not only supports its advanced features but also general-purpose SMU commands (such as those used by the Keithley 2400) to simplify test program migration. In addition to SCPI, the IVI-COM drivers for the B2900A Series of SMUs work in a variety of programming environments and languages so that you can develop programs without having to use low-level commands.

Summary

The Keysight B2901/02/11/12A Precision Source/Measure Unit is the best solution for IV characterization of LEDs and a variety of other devices. Its wide current and voltage measurement ranges (from 10 fA/100 nV to 10.5 A/210 V) provide superior measurement performance and allow you to characterize devices more accurately and easily than ever before.

The easy-to-use GUI of the B2900A Series of SMUs has a variety of capabilities and features that make it easy to take measurements quickly and to save both the measurement setup conditions and data to USB-based flash memory devices.

In addition to being able to control the B2900A Series of SMUs remotely over GPIB, USB and LAN interfaces, Keysight supplies PC-based Keysight B2900A Graphical Web Interface and Keysight B2900A Quick I/V Measurement Software for free to simplify controlling the B2900A Series of SMUs from your PC.

For more detailed information on the various models of the B2900A Series of SMUs, please refer to the data sheet of the B2900A Series of SMUs (5990-7009EN).

The B2900A Series of SMUs enables you to quickly debug and accurately characterize a wide variety of devices using only a single bench-top SMU.

The dual-channel models of the B2900A Series of SMUs permit provide L-I-V test capabilities using its two SMU channels. For more information, please refer to the technical overview, LIV Test of Laser Diode Using the Keysight B2900A Series of SMUs (5990-7115EN).

Keysight B2961A/B2962A 6.5 digit Low Noise Power Source



If you need more source capabilities, the best choice is Keysight Power Source. See our B2900A series lineup.

www.keysight.com/find/b2900a

myKeysight

myKeysight

www.keysight.com/find/mykeysight

A personalized view into the information most relevant to you.



www.axistandard.org

AdvancedTCA® Extensions for Instrumentation and Test (AXIe) is an open standard that extends the AdvancedTCA for general purpose and semiconductor test. Keysight is a founding member of the AXIe consortium. ATCA®, AdvancedTCA®, and the ATCA logo are registered US trademarks of the PCI Industrial Computer Manufacturers Group.



www.lxistandard.org

LAN eXtensions for Instruments puts the power of Ethernet and the Web inside your test systems. Keysight is a founding member of the LXI consortium.



www.pxisa.org

PCI eXtensions for Instrumentation (PXI) modular instrumentation delivers a rugged, PC-based high-performance measurement and automation system.



Keysight Assurance Plans

www.keysight.com/find/AssurancePlans

Up to five years of protection and no budgetary surprises to ensure your instruments are operating to specification so you can rely on accurate measurements.



www.keysight.com/quality

Keysight Technologies, Inc.
DEKRA Certified ISO 9001:2008
Quality Management System

Keysight Channel Partners

www.keysight.com/find/channelpartners

Get the best of both worlds: Keysight's measurement expertise and product breadth, combined with channel partner convenience.

www.keysight.com/find/precisionsmu

For more information on Keysight Technologies' products, applications or services, please contact your local Keysight office. The complete list is available at: www.keysight.com/find/contactus

Americas

Canada	(877) 894 4414
Brazil	55 11 3351 7010
Mexico	001 800 254 2440
United States	(800) 829 4444

Asia Pacific

Australia	1 800 629 485
China	800 810 0189
Hong Kong	800 938 693
India	1 800 112 929
Japan	0120 (421) 345
Korea	080 769 0800
Malaysia	1 800 888 848
Singapore	1 800 375 8100
Taiwan	0800 047 866
Other AP Countries	(65) 6375 8100

Europe & Middle East

Austria	0800 001122
Belgium	0800 58580
Finland	0800 523252
France	0805 980333
Germany	0800 6270999
Ireland	1800 832700
Israel	1 809 343051
Italy	800 599100
Luxembourg	+32 800 58580
Netherlands	0800 0233200
Russia	8800 5009286
Spain	0800 000154
Sweden	0200 882255
Switzerland	0800 805353
	Opt. 1 (DE)
	Opt. 2 (FR)
	Opt. 3 (IT)
United Kingdom	0800 0260637

For other unlisted countries:
www.keysight.com/find/contactus
(BP-07-10-14)

