

11941A CLOSE-FIELD PROBE

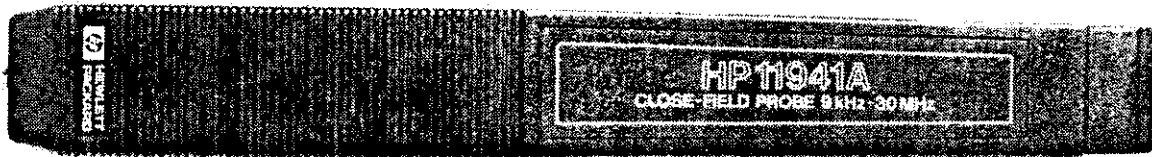

July 1987
Copyright © Hewlett-Packard Company
1212 Valley House Drive
Rohnert Park, CA 94928-4999 U.S.A.



CERTIFICATION

Hewlett-Packard Company certifies that this product met its published specifications at the time of shipment from the factory. Hewlett-Packard further certifies that its calibration measurements are traceable to the United States National Bureau of Standards, to the extent allowed by the Bureau's calibration facility, and to the calibration facilities of the other International Standards Organization members.

WARRANTY

This Hewlett-Packard instrument product is warranted against defects in material and workmanship for a period of one year from date of shipment. During the warranty period, Hewlett-Packard Company will, at its option, either repair or replace products which prove to be defective.

For warranty service or repair, this product must be returned to a service facility designated by HP. Buyer shall prepay shipping charges to HP and HP shall pay shipping charges to return the product to Buyer. However, Buyer shall pay all shipping charges, duties, and taxes for products returned to HP from another country.

HP warrants that its software and firmware designated by HP for use with an instrument will execute its programming instructions when properly installed on that instrument. HP does not warrant that the operation of the instrument, or software, or firmware will be uninterrupted or error-free.

LIMITATION OF WARRANTY

The foregoing warranty shall not apply to defects resulting from improper or inadequate maintenance by Buyer, Buyer-supplied software or interfacing, unauthorized modification or misuse, operation outside of the environmental specifications for the product, or improper site preparation or maintenance.

NO OTHER WARRANTY IS EXPRESSED OR IMPLIED. HP SPECIFICALLY DISCLAIMS THE IMPLIED WARRANTIES OF MERCHANTABILITY AND FITNESS FOR A PARTICULAR PURPOSE.

EXCLUSIVE REMEDIES

THE REMEDIES PROVIDED HEREIN ARE BUYER'S SOLE AND EXCLUSIVE REMEDIES. HP SHALL NOT BE LIABLE FOR ANY DIRECT, INDIRECT, SPECIAL, INCIDENTAL, OR CONSEQUENTIAL DAMAGES, WHETHER BASED ON CONTRACT, TORT, OR ANY OTHER LEGAL THEORY.

ASSISTANCE

Product maintenance agreements and other customer assistance agreements are available for Hewlett-Packard products.

For any assistance, contact your nearest Hewlett-Packard Sales and Service Office. Addresses are provided at the back of this manual.

CONTENTS

1-1. General Information	1
1-2. Description	1
1-4. Accessories Supplied	1
1-6. Options	1
1-11. Initial Inspection	1
2-1. Specifications	2
3-1. Operation	2
3-2. Theory of Operation	2
3-4. Antenna Factors	2
3-7. Power Density and Electric Field Calculations	4
3-9. Localized Field Source	4
3-11. Test Setups	5
3-16. Measurement Techniques	8
4-1. Operation Verification	10
4-5. Calibration Cycle	10
4-8. Output Impedance Measurement Test	10
4-9. Insertion Loss Measurement Test	13
5-1. Replaceable Parts	15
5-3. SMA Adapter Replacement Procedure	16
5-4. SMA Rotary Joint Installation Procedure (Option 001)	16
5-5. Ordering Information	17
5-7. Direct Mail-Order System	17
6-1. Factory Returns	17

SAFETY SYMBOLS

The following safety symbols are used throughout this manual and in the instrument. Familiarize yourself with each of the symbols and its meaning before operating this instrument.



Instruction manual symbol. The instrument will be marked with this symbol when it is necessary for the user to refer to the instruction manual in order to protect the instrument against damage. Location of pertinent information within the manual is indicated by use of this symbol in the table of contents.



Indicates dangerous voltages are present. Be extremely careful.

CAUTION

The CAUTION sign denotes a hazard. It calls attention to a procedure which, if not correctly performed or adhered to, could result in damage to or destruction of the instrument. Do not proceed beyond a CAUTION sign until the indicated conditions are fully understood and met.

WARNING

The WARNING sign denotes a hazard. It calls attention to a procedure which, if not correctly performed or adhered to, could result in injury or loss of life. Do not proceed beyond a WARNING sign until the indicated conditions are fully understood and met.

1-1. GENERAL INFORMATION

1-2. Description

1-3. The HP 11941A Close-Field Probe is a hand-held electromagnetic field sensor designed to make repeatable, calibrated magnetic field measurements from 9 kHz to 30 MHz. It is optimized for the location and measurement of sources of electromagnetic interference (EMI) in electronic equipment. The HP 11941A can also be used as a localized magnetic field source when operated in conjunction with an appropriate signal generator, thereby allowing circuit-board-level susceptibility testing of instruments.

1-4. Accessories Supplied

1-5. The following three accessories are included with the probe:

- One 2m (6.6 ft.) double-shielded RF cable with two SMA (male) end connectors, HP Part Number 8120-4811
- One Type N (male) to SMA (female) adapter, HP Part Number 1250-1250
- One BNC (male) to SMA (female) adapter, HP Part Number 1250-1700

The double-shielded cable (RG-223), reduces measurement errors in high field impedance environments by minimizing current leakage through the braided coaxial outer conductors. For less demanding applications, the use of a more flexible single-shielded cable type is sufficient (e.g., RG-58, RG-174).

1-6. Options

1-7. Three options are available for the HP 11941A.

1-8. Option 001 includes a factory-installed SMA RF Rotary Joint connector, HP Part Number 0955-0323. Check Digit 5. (See figure 17.) The connector increases handling flexibility of the probe by removing any rotational torque from the interconnect cable. The rotary joint is especially useful when making measurements using the double-shielded cable. Section 5-4 includes instructions on installing the rotary joint.

1-9. Option 003 consists of the HP 11941A Close-Field Probe without the double-shielded cable or the two adapters.

1-10. Option 910 includes an additional Operation Note.

1-11. Initial Inspection

1-12. If the shipment contents are incomplete or damaged, notify the nearest Hewlett-Packard office. If the shipping container is damaged, or the cushioning material shows signs of stress, notify the carrier as well as the Hewlett-Packard office. Keep the shipping materials for the carrier's inspection. The HP office will arrange for repair or replacement without waiting for a claim settlement.

1-13. See Paragraph 4-1 for Operation Verification.

2-1. SPECIFICATIONS

2-2. Specifications for the HP 11941A are listed in table 1. An asterisk (*) placed after an entry indicates a supplemental characteristic. Supplemental characteristics are not specifications, but are characteristics included as additional information for the user.

2-3. Figure 1 illustrates the characteristic frequency response for the HP 11941A Close-Field Probe. See section 3-4, Antenna Factors, for additional information.

3-1. OPERATION

3-2. Theory of Operation

3-3. The HP 11941A is a balanced magnetic-field sensor that provides an output voltage proportional to the strength of the magnetic field at its tip. Radiated magnetic fields couple directly to the HP 11941A and produce an output signal; radiated electric fields also couple to the HP 11941A, but do not produce an output voltage due to the construction of the probe. The HP 11941A uses a dual-loop sensor and a balun to reject electrically-coupled signals. These loops are illustrated in figure 2, which shows the probe with its non-removable protective tip cover cut away for clarity.

The probe does not rectify the input signal; it provides both amplitude and frequency information. It is ideally suited for use with a spectrum analyzer. The HP 11941A circuitry is passive and therefore only contributes thermal noise to any measurement system. Inspect the probe tip for damage before using, and do not use the probe if the protective tip cover is missing or damaged.

3-4. Antenna Factors

3-5. The specific antenna factors of each HP 11941A are measured to within ± 2 dB at five frequencies: 9 kHz, 100 kHz, 1 MHz, 10 MHz, and 30 MHz. This calibration information is listed on the bottom cover of each probe. The antenna factors are given in the units of dB($\mu\text{A}/\text{m}/\mu\text{V}$). To calculate the magnetic field strength in dB($\mu\text{A}/\text{m}$) at a specific frequency, add the amplitude of the measured voltage in dB(μV) (as indicated on the spectrum analyzer) to the antenna factor for that specific frequency. To compensate for cable losses and preamplifier gains, add the losses and subtract the gains (in dB). Refer to the following equation:

$$\bar{H}\text{-Field Strength} \left(\text{dB} \frac{\mu\text{A}}{\text{m}} \right) = V_{\text{SA}} + \text{AF} + K$$

where

V_{SA} = voltage in dB μV measured on analyzer

AF = HP 11941A Antenna Factor in dB $\left(\frac{\mu\text{A}/\text{m}}{\mu\text{V}} \right)$

K = loss or gain in dB between HP 11941A and spectrum analyzer
(Positive value if loss, negative value if gain.)

Table 1. HP 11941A Specifications

Antenna Factor:	Measured for each unit at 0.009, 0.100, 1, 10, and 30 MHz to within ± 2 dB in a 377-ohm field impedance. See Figure 1 for characteristic antenna factor data.
Temperature Range:*	0°C to +40°C: $< \pm 1$ dB (Operating) -10°C to +65°C (Storage)
Frequency Range:	9 kHz–30 MHz
Connector:	SMA, replaceable barrel
Maximum Input Power:	0.5 watts
Maximum voltage at tip:*	1 kV (dc + peak ac)
Weight:*	Net: 0.10 kg (0.22 lbs) Shipping: 0.56 kg (1.2 lbs)

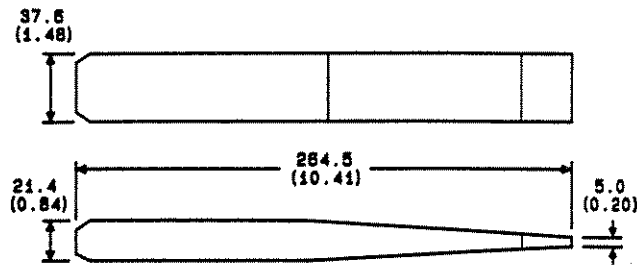

DIMENSIONS IN MILLIMETERS AND (INCHES)

*supplemental characteristic

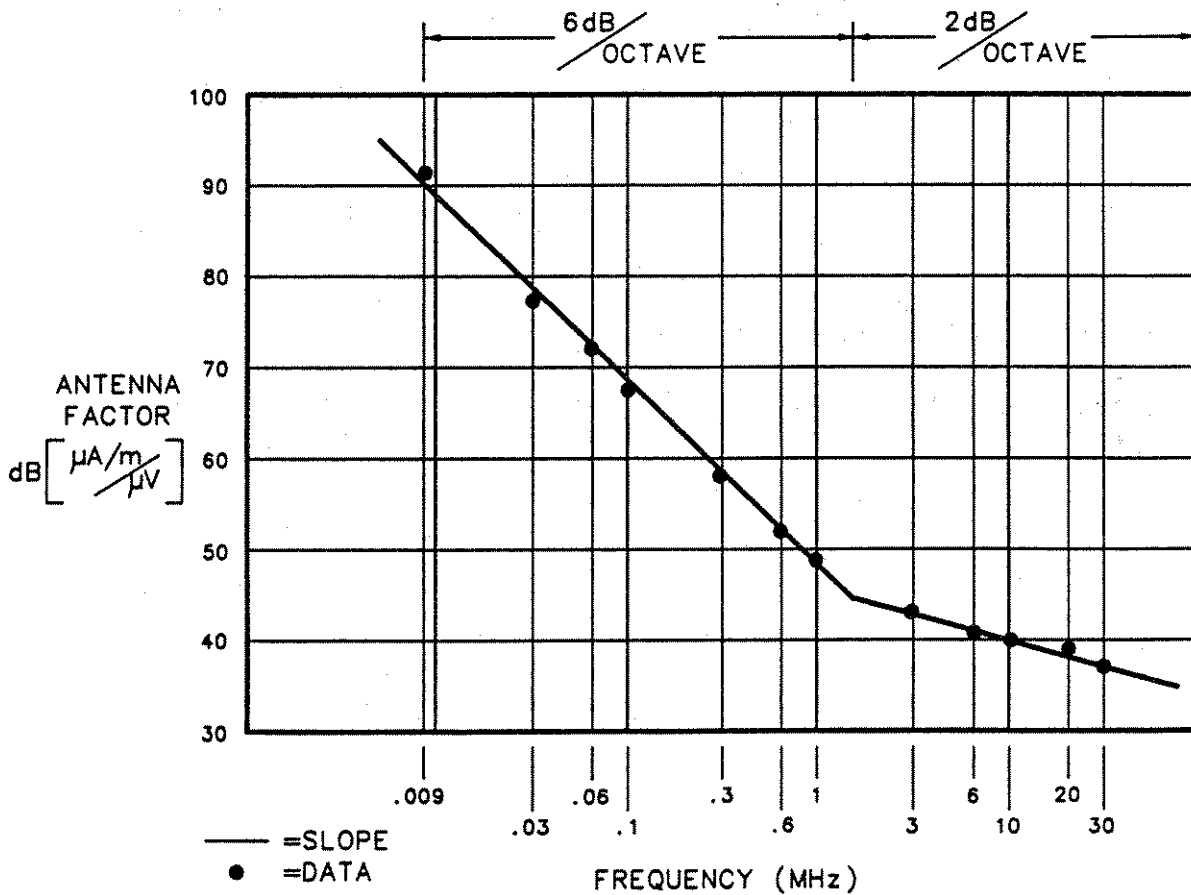

Figure 1. HP 11941A Characteristic Antenna Factors, 9 kHz–30 MHz

3-6. Use the data included in figure 1 for interpolating antenna factors between the five calibration frequencies included in the probe's calibration table.

3-7. Power Density and Electric Field Calculations

3-8. The HP 11941A measures magnetic field strength. An estimate of the magnitude of the associated electric field can be made if a field impedance is assumed. An example is given below using a 377-ohm field impedance. Radiated power density can also be estimated, assuming that the fields are in phase and that the field impedance is 377 ohms.

$$\begin{aligned} \text{E-Field Strength } \left(\text{dB } \frac{\mu\text{V}}{\text{m}} \right) &= V_{\text{SA}} + \text{AF} + \text{K} + 20 \log(377) \\ &= V_{\text{SA}} + \text{AF} + \text{K} + 51.5 \end{aligned}$$

$$\text{Power Density } \left(\text{dB } \frac{\text{mW}}{\text{cm}^2} \right) = V_{\text{SA}} + \text{AF} + \text{K} - 104.3$$

where

V_{SA} = voltage in $\text{dB}\mu\text{V}$ measured on analyzer

AF = HP 11941A Antenna Factor in $\text{dB} \left(\frac{\mu\text{A}/\text{m}}{\mu\text{V}} \right)$

K = loss or gain in dB between HP 11941A and spectrum analyzer
(Positive value if loss, negative value if gain.)

EXAMPLE:

At 10 MHz, measured $V_{\text{SA}} = 65.3 \text{ dB}\mu\text{V}$. Let $\text{K} = 0$ and $\text{AF} = 39 \text{ dB} \left(\frac{\mu\text{A}/\text{m}}{\mu\text{V}} \right)$.

then

$$\text{E } \left(\text{dB } \frac{\mu\text{V}}{\text{m}} \right) = 65.3 + 39 + 51.5 = 155.8 \text{ dB}\mu\text{V}/\text{m} = 61.7 \text{ V}/\text{m}$$

$$\text{S } \left(\text{dB } \frac{\text{mW}}{\text{cm}^2} \right) = 65.3 + 39 - 104.3 = 0 \text{ dB } \frac{\text{mW}}{\text{cm}^2} = 1 \frac{\text{mW}}{\text{cm}^2}$$

3-9. Localized Field Source

3-10. The probe can also be used as a localized magnetic field source for locating susceptible components on a circuit board. It is a reciprocal device; that is, a current fed into the probe will generate a magnetic field at the dual-loop sensor. The specified antenna factors cannot be used to estimate the magnitude of the output field. Table 2 lists characteristic field strengths developed 1 mm (0.040 in.) away from the probe tip, using an incident power of 0 dBm into 50 ohms.

CAUTION

Power applied to the probe must not exceed the maximum input power listed in table 1 or damage to the probe will result.

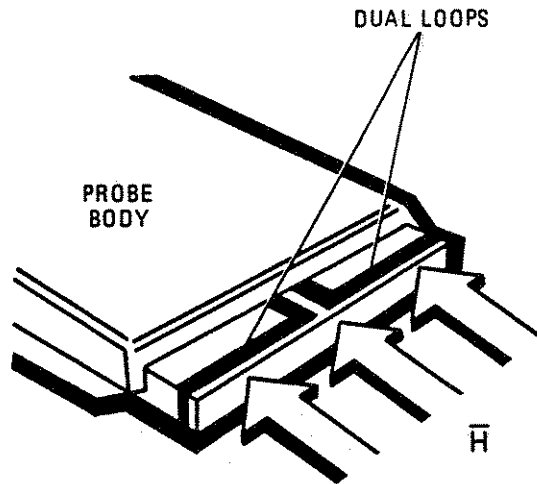

Figure 2. Magnetic Field Orientation for Maximum Coupling

Table 2. Characteristic Magnetic Field Strengths

Frequency (MHz)	Input Power (into 50Ω)	Magnetic Field Strength (H), dB (μA/m)
0.009	0 dBm	122
0.100	0 dBm	120
1	0 dBm	120
10	0 dBm	110
30	0 dBm	101

3-11. Test Setups

3-12. The HP 11941A operates as either a localized magnetic field probe or localized magnetic field source. The following paragraphs describe different applications and test setups for the probe. Table 3 lists the recommended test setup equipment used in these examples. Any equipment that satisfies the critical specifications listed in table 3 may be substituted for the recommended equipment. When used as a probe, be sure to add the antenna factors and cable losses to the signal levels indicated on the spectrum analyzer. If a preamplifier is used to increase measurement sensitivity, subtract its gain from the displayed signal level.

WARNING

The dielectric material on the tip of the probe has a characteristic breakdown voltage of 1 kV. To prevent damage to the probe and/or personal injury to the user, the probe should not be used where a potential of over 1 kV is available.

3-13. **Localized Emissions Test Setup:** figure 3 illustrates a typical configuration used for localizing EMI emissions. See section 3-16 for proper probe placement.

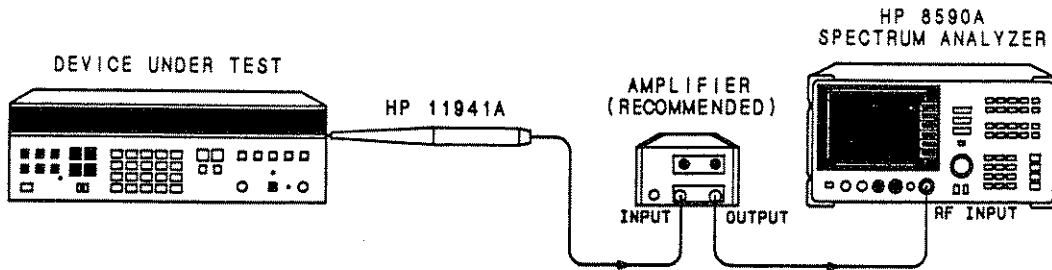

Figure 3. Localized Emissions Test Setup

Table 3. Recommended Test Setup Equipment

Instrument	Critical Specifications	Recommended Model
Spectrum Analyzer	Frequency Range: 9 kHz–30 MHz	HP 8562A (100 Hz–2.9 GHz) HP 8566B (100 Hz–300 GHz) HP 8567A (10 kHz–1.5 GHz) HP 8568B (100 Hz–1.5 GHz) HP 8590A (10 kHz–1.5 GHz) Option H51, Close-Field EMC Feature Set HP 71100A (100 Hz–2.9 GHz) Option 002
Tracking Generator	Frequency Range: 9 kHz–30 MHz	HP 8444A (0.5–1500 MHz) Option 059. For use with HP 8566B, HP 8567A, and HP 8568B HP 70300A (100 Hz–2.9 GHz) For use with HP 71100A
Signal Generator	Frequency Range: 9 kHz–30 MHz	HP 8660C (10 kHz–2.6 GHz) HP 8662A (10 kHz–1280 MHz)
Preamplifier*	Frequency Range: 9 kHz–30 MHz RF Gain: >20 dB	HP 8447A (9 kHz–50 MHz) Option H64 HP 8447F (9 kHz–1.3 GHz) Option H64
* An HP 85685A RF Preselector may be substituted if an HP 8566B, HP 8567A, or HP 8568B spectrum analyzer is used.		

3-14. Stimulus-Response Test Setup: The relative shielding effectiveness of various enclosures and shielded structures can be tested using stimulus-response techniques. See figure 4. The tracking generator output signal radiates from an antenna placed inside the enclosure under test, while the probe and spectrum analyzer provide frequency and relative amplitude information. See section 3-16 for proper probe placement.

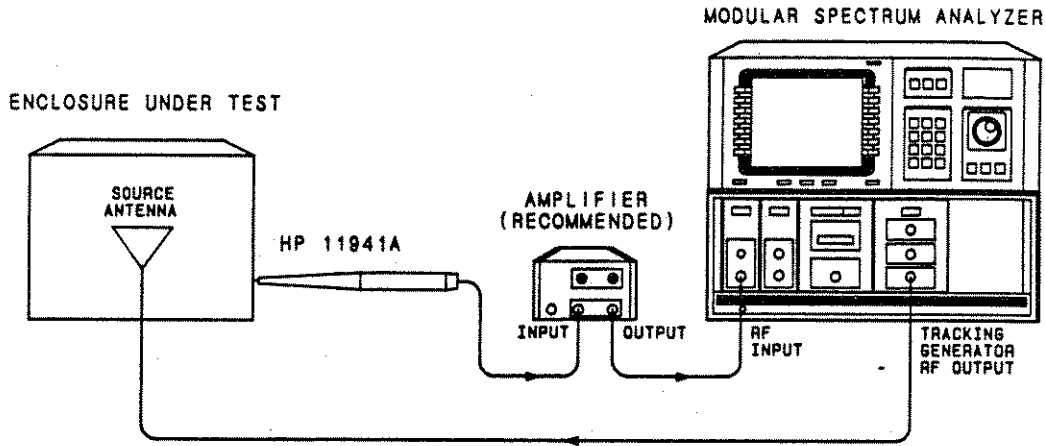

Figure 4. Stimulus-Response Test Setup

3-15. Localized Susceptibility Test Setup: Used as a field source, the probe provides a magnetic field for susceptibility testing of electronic devices. The distance between the probe tip and the Device Under Test (DUT) should be less than 1 cm (0.394 in.). As the probe is moved closer to the DUT, the absolute magnetic field strength applied to the DUT approaches the calculated value produced at the probe tip. For broadband susceptibility testing, use the probe with a swept or tracking source. See figure 5 for an example of the basic localized susceptibility test setup.

CAUTION

Power applied to the probe must not exceed the maximum input power listed in table 1 or damage to the probe will result.

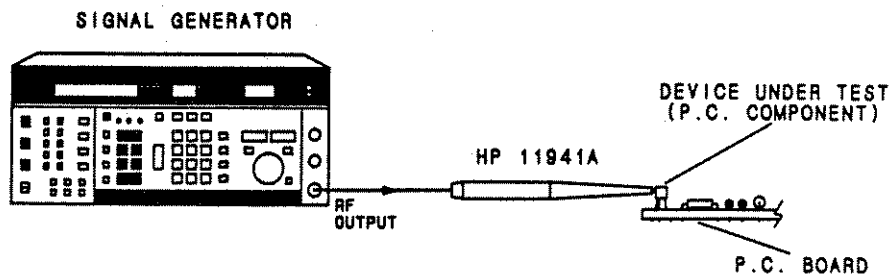

Figure 5. Localized Susceptibility Test Setup

3-16. Measurement Techniques

3-17. The HP 11941A measures the magnetic field strength at the center of its sense loop, not at the probe tip. Figure 6 details the relationship between the probe tip cover and the probe loop centerline. The probe is designed to be held very close to potential radiating points. The plane of the probe tip loops must be perpendicular to the radiating magnetic field as illustrated in figure 2. For example, if the seam of an enclosure is being tested for EMI, hold the probe as illustrated in figure 7. When measuring the radiation from a coaxial cable, position the probe as in figure 8, which shows the sense loops. The side of the probe with the antenna factor calibration label should be facing away from the cable being measured. Do not use the probe if the protective tip cover is missing or damaged.

3-18. The probe may be used as a source in susceptibility testing, as described in section 3-9 and also in paragraph 3-15. In this application, hold the probe within 1 cm (0.394 in.) of the electronic circuit component being tested.

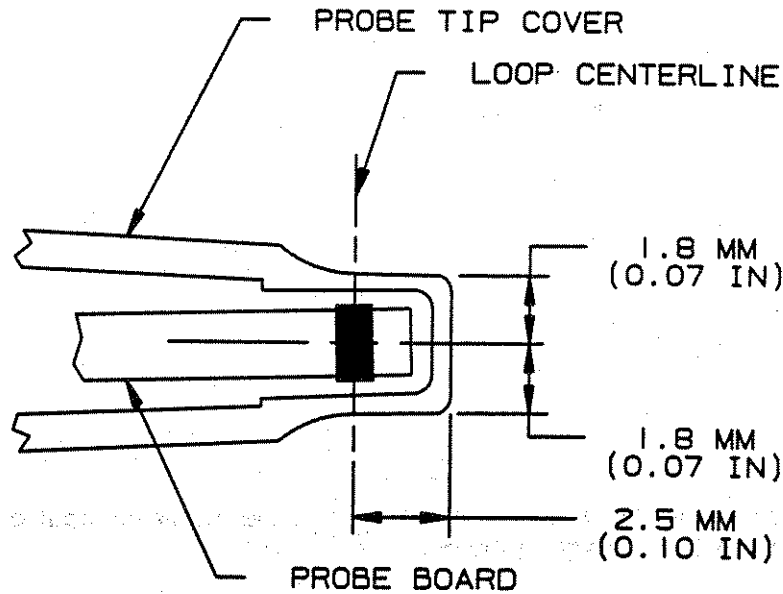

Figure 6. Probe Tip Detail

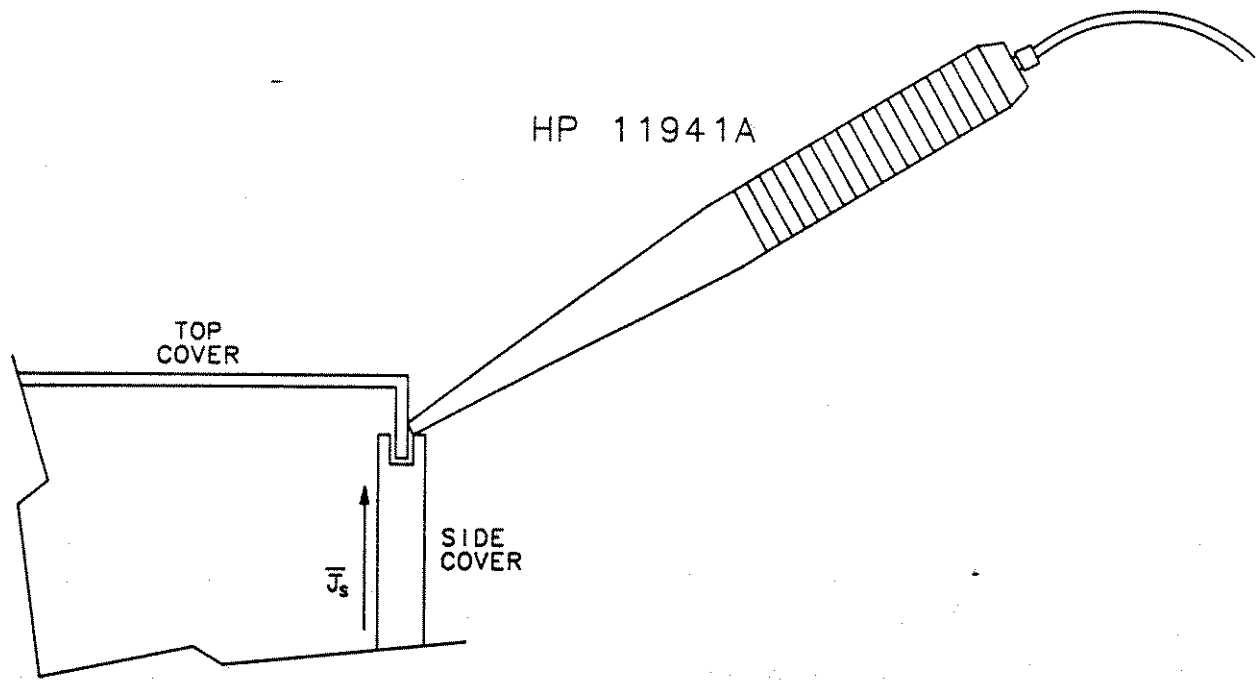

Figure 7. Testing an Enclosure Seam

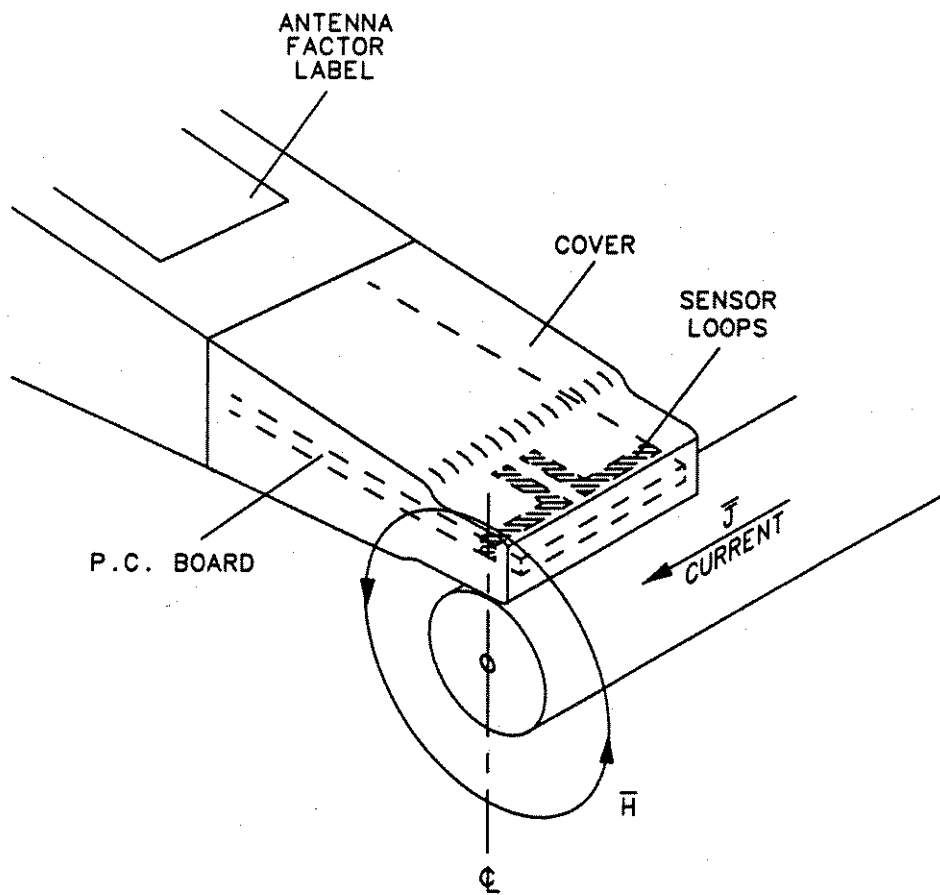

Figure 8. Testing a Coaxial Cable

4-1. OPERATION VERIFICATION

4-2. Operation Verification for the HP 11941A consists of two tests: an output impedance measurement test, and an insertion loss measurement test. Each test is relative and designed to detect damage in specific parts of the circuitry. These tests are not designed to verify antenna-factor calibration, which requires a calibrated magnetic field.

4-3. Probes that fail these tests may still detect electromagnetic radiation. In this case, the probe circuitry no longer rejects electric field coupling and the antenna factors listed on the unit are no longer valid.

4-4. In the test procedures, instrument softkeys will be represented by *shadow* print. Softkeys are keys whose function is defined by text on the display.

4-5. Calibration Cycle

4-6. Field-site recalibration of the HP 11941A antenna factors is not possible. However, the probe's antenna factors can be recalibrated at the factory. A three (3) year recertification cycle is recommended. Refer to section 6-1 for factory recalibration information.

4-7. The HP 11941A contains no internal user-accessible adjustments or parts. The SMA adapter (see figure 16) is the only external replaceable part.

4-8. Output Impedance Measurement Test

Description

This test measures the impedance of the HP 11941A at the SMA port, over a frequency range of 100 kHz to 1 MHz, to detect any damage in the output circuitry. Any equipment that satisfies the following critical specifications for the test setup may be substituted for the recommended equipment:

Frequency Range	100 kHz to 1 MHz
Test Port Match	>15 dB Return Loss

Recommended Equipment

Network Analyzer	HP 3577A
S-Parameter Test Set	HP 35677A

Adapters:

Type N (m) to APC 3.5 (m)	HP 1250-1743
---------------------------------	--------------

Accessories:

50 ohm Load, APC 3.5 (f)	HP 909D, Option 011
Coaxial Short, APC 3.5 (f)	HP 1250-1769
Open, APC 3.5 (f)	HP 1250-1767

Procedure

1. Connect the equipment as shown in figure 9. Allow the HP 3577A 60 minutes of warm-up time.

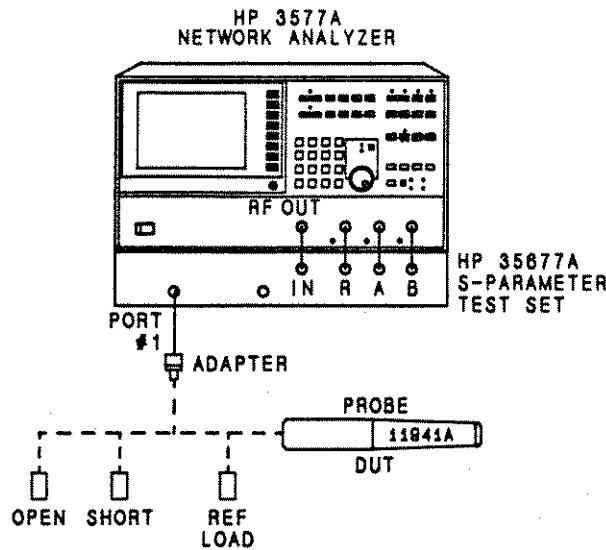

Figure 9. Output Impedance Test Setup

2. Set the HP 3577A controls as follows:

TRACE 1	
INPUT	S11
DISPLAY FUNCTION	POLAR
SMITH CHART	ON
FULL SCALE	1 UNIT
SWEEP TYPE	Lin. Freq. Sweep
SWEEP MODE	Cont.
START FREQ	100 kHz
STOP FREQ	1 MHz
AMPTD	+15 dBm

3. Perform the full one-port calibration by pressing the Measr Cal key and *One Port Full Cal.* Follow the directions on the display.
4. Connect the probe to Port One of the HP 35677A. The impedance display should appear as shown in figure 10. At 100 kHz the measured impedance should approximate that of a short circuit; at 1 MHz the probe should measure inductively, with a maximum normalized impedance value of $j0.50$. The most common failure mode for this test would be an open in the input circuitry, in which case the impedance display would appear as shown in figure 11.

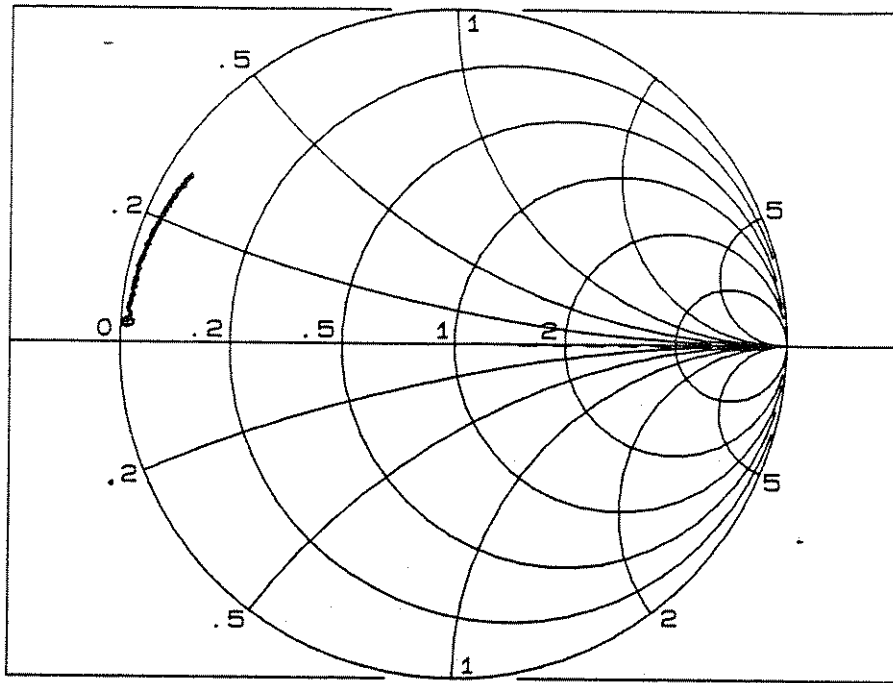

Figure 10. Impedance Plot of Functional HP 11941A
(100 kHz to 1 MHz)

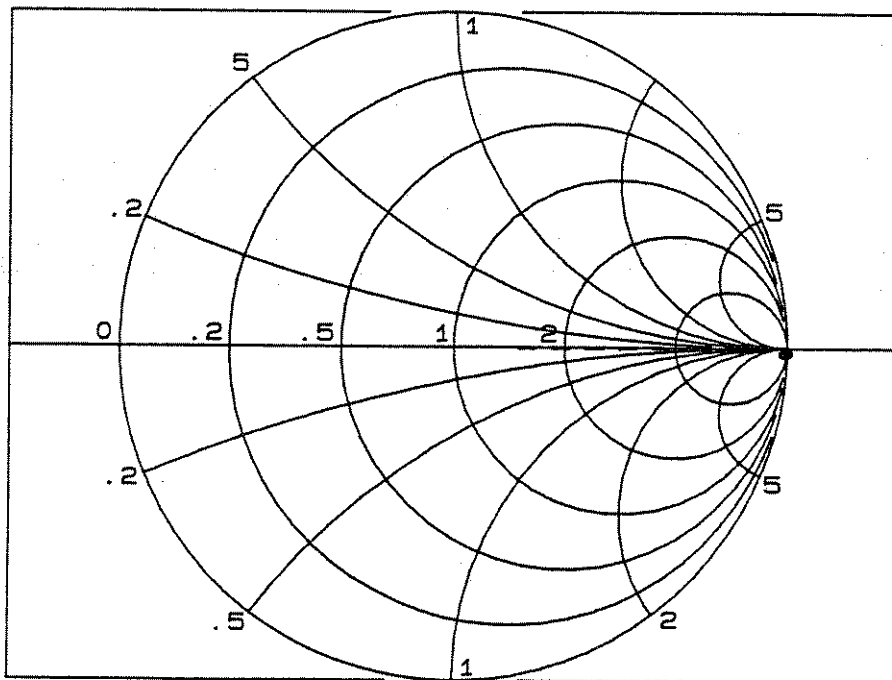

Figure 11. Impedance Plot of HP 11941A with Open Circuit
(100 kHz to 1 MHz)

4-9. Insertion Loss Measurement Test

Description

The insertion loss test is a relative indicator of damage in the input circuitry. Using a second HP 11941A as a magnetic field source, this test selectively injects a magnetic field into each loop of the HP 11941A being tested. Damage is indicated by differences in the measured output voltages. It is important to orient the two probes properly as shown in figures 12 through 15. To facilitate testing, the source probe should be fixed in place, the tip flush with the work surface (preferably wooden). This can be accomplished with clamps or tape, which should be no closer than 50.8 mm (2 in.) to the source tip. Other test equipment may be substituted if it meets or exceeds the critical specifications for the instruments listed below. Throughout the test procedure, the probe being tested will be referred to as the DUT (Device Under Test).

Recommended Equipment

Network Analyzer HP 3577A
 S-Parameter Test Set HP 35677A
 Field-Source HP 11941A

Adapters:
 Type N (m) to APC 3.5 (m) (2 required) HP 1250-1743

Cables:
 SMA (m) to SMA (m), 2m (2 required) HP 8120-4811

Procedure

1. Connect the equipment as shown in figure 12. Allow the HP 3577A 60 minutes of warm-up time.

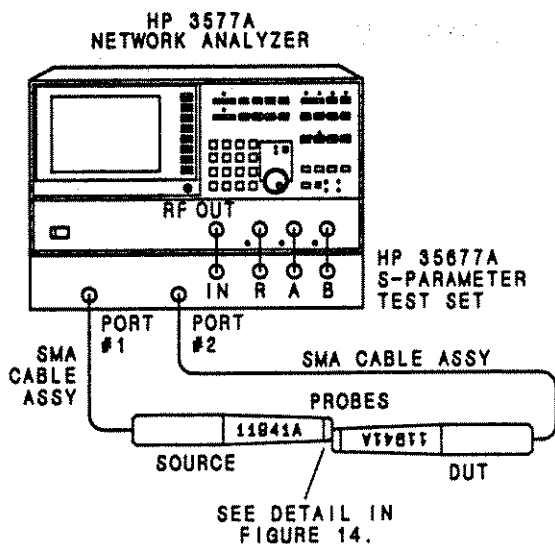

Figure 12. Insertion Loss Test Setup

2. Set the HP 3577A as follows:

```

INST PRESET
TRACE 1
INPUT ..... S21
DISPLAY FUNCTION ..... Log Mag
REF LEVEL ..... -30 dBm
SCALE ..... 5 dB/Div
REF POS ..... 100 %

SWEEP TYPE ..... Log Freq Sweep
SWEEP MODE ..... Cont.
START FREQ ..... 100 kHz
STOP FREQ ..... 30 MHz

AMPTD ..... +15 dBm
    
```

3. Physically align the probes as shown in figures 13 and 14. The identification label of the DUT should face upward. This alignment illuminates one of the sense loops of the DUT with a magnetic field.

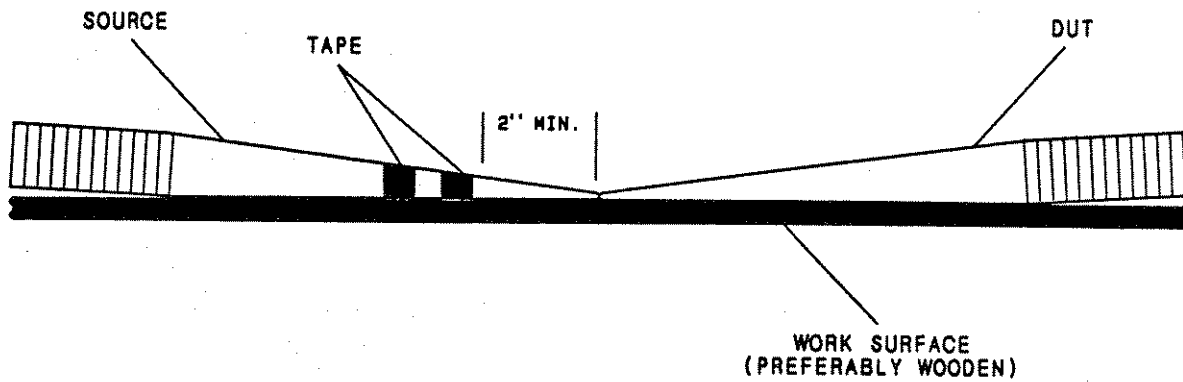

Figure 13. Probe Orientation for Insertion Loss Test

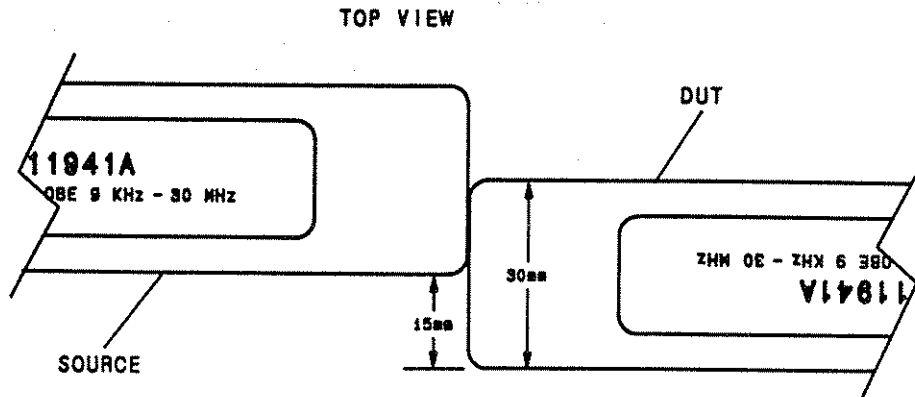

Figure 14. Detail of Probe Orientation for Insertion Loss Test (Measurement of Loop #1)

4. Press the STORE DATA key, then *Store & Display*.
5. Realign the DUT as shown in figure 15. The calibration label of the DUT should face upward. This position illuminates the second sense loop of the DUT with the same magnetic field intensity as the first loop.
6. Press the STORE DATA key and *Store Reg 01*. Then press the INPUT key and *Data Reg*.

The two displayed traces will typically be ≤ 3 dB apart for properly functioning probes, and > 6 dB apart for damaged probes. If your measurements are repeatedly yielding results between 3 dB and 6 dB, then the test setup should be checked.

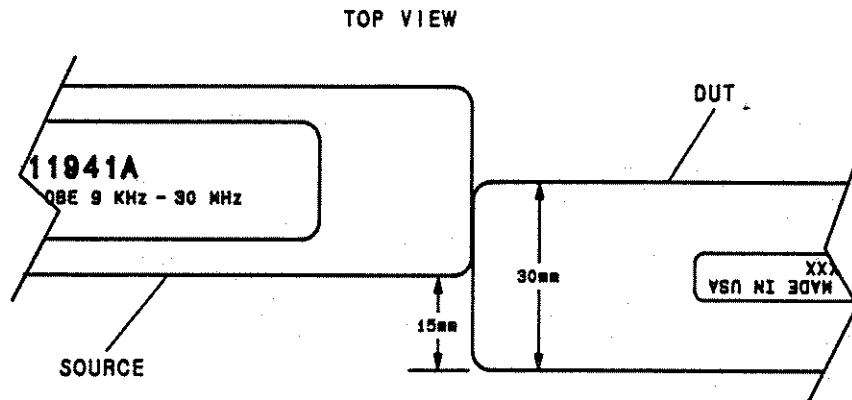

Figure 15. Detail of Probe Orientation for Insertion Loss Test
(Measurement of Loop #2)

5-1. REPLACEABLE PARTS

5-2. The SMA adapter located at the end of the probe is the only replaceable part on the HP 11941A (see figure 16). It protects the probe's integral connector from mechanical damage and should be left on. Should the end of the adapter become worn or damaged through use, it can be replaced using the procedure outlined in paragraph 5-3.

SMA Adapter HP Part Number 1250-1158
Check Digit 3

Loctite 222® HP Part Number 0470-0573
Check Digit 9

5-3. SMA Adapter Replacement Procedure

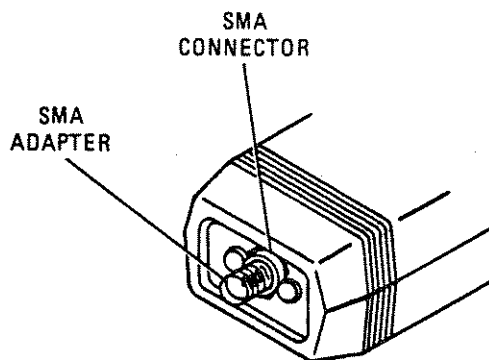

Figure 16. SMA Adapter Location

1. Use a 7/32-inch wrench to remove the old SMA adapter (see figure 16). Turn the adapter counterclockwise as viewed from the rear end of the probe.
2. Place a small amount of Loctite 222® on two or three end threads of the new SMA adapter.
3. Screw the new adapter clockwise into the probe's SMA connector.
4. Using a torque wrench, tighten the adapter to 24 inch-pounds.

5-4. SMA Rotary Joint Installation Procedure (Option 001)

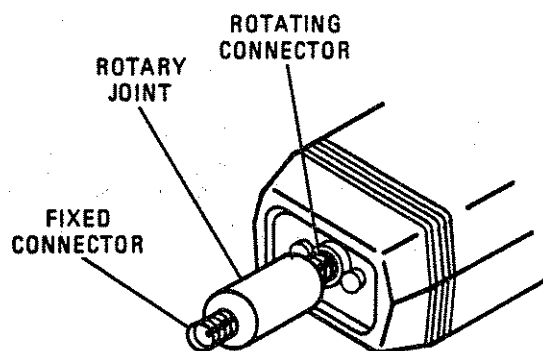

Figure 17. RF Rotary Joint Mounted on Probe (Option 001)

1. Use a 7/32-inch wrench to remove the old SMA adapter (see figure 16). Turn the adapter counterclockwise as viewed from the rear end of the probe.
2. The SMA Rotary Joint has an SMA connector located at each end. One connector rotates with respect to the body of the rotary joint. The other connector is fixed to the body. Cover two or three end threads of the rotating end connector with a small amount of Loctite 222®.

3. Screw the rotating end of the rotary joint clockwise into the probe's SMA connector (see figure 17).
4. Using a 9/32-inch torque wrench, tighten the rotary joint to 24 inch-pounds.
5. When attaching a cable to the rotary joint, hold the rotary joint by hand to keep the connector from turning.

5-5. Ordering Information

5-6. To order a part, quote the Hewlett-Packard part number (with check digit), indicate the quantity required, and address the order to the nearest Hewlett-Packard office. The check digit will ensure accurate and timely processing of your order.

5-7. Direct Mail-Order System

5-8. Within the U.S.A., Hewlett-Packard can supply parts through a direct mail-order system. Advantages of using the system are as follows:

- a. Direct ordering and shipment from the HP Parts Center in Mountain View, California
- b. No minimum or maximum purchase requirement on any mail order. (There is a minimum order amount for parts ordered through a local HP office when the orders require billing and invoicing.)
- c. Prepaid transportation. (There is a small handling charge for each order.)
- d. No invoices

To provide these advantages, a check or money order must accompany each order. Mail-order forms and specific ordering information are available through your local HP office.

6-1. FACTORY RETURNS

6-2. The 11941A probe may be returned to the factory for recalibration. The probe should be properly packaged and shipped to:

HEWLETT-PACKARD COMPANY
ATTN: WARRANTY ADMINISTRATOR, 11941A REPAIR
1212 VALLEY HOUSE DRIVE
ROHNERT PARK, CA 94928-4999
U.S.A.

HEWLETT-PACKARD SALES AND SERVICE OFFICES

To obtain servicing information or to order replacement parts, contact the nearest Hewlett-Packard Sales and Service Office listed in the HP Catalog, or contact the nearest regional office listed below:

IN THE UNITED STATES

CALIFORNIA
P.O. Box 4230
1421 South Manhattan Avenue
Fullerton 92631

GEORGIA
P.O. Box 105005
2000 South Park Place
Atlanta 30339

ILLINOIS
5201 Tollview Drive
Rolling Meadows 60008

NEW JERSEY
W. 120 Century Road
Paramus 07652

IN CANADA

Hewlett-Packard (Canada) Ltd.
17500 South Service Road
Trans-Canada Highway
Kirkland, Quebec H9J 2M5

IN FRANCE

Hewlett-Packard France
F-91947 Les Ulis Cedex
Orsay

IN GERMAN FEDERAL REPUBLIC

Hewlett-Packard GmbH
Vertriebszentrale Frankfurt
Berner Strasse 117
Postfach 560 140
D-6000 Frankfurt 56

IN GREAT BRITAIN

Hewlett-Packard Ltd.
King Street Lane
Winnersh, Wokingham
Berkshire RG11 5AR

IN OTHER EUROPEAN COUNTRIES

SWITZERLAND
Hewlett-Packard (Schweiz) AG
29 Chemin Chateau Bloc
CH-1219 LeLignon-Geneva

IN ALL OTHER LOCATIONS

Hewlett-Packard Inter-Americas
3200 Hillview Avenue
Palo Alto, California 94304

