Training Guide

Publication Number E2433-97034
First Edition, November 1997

For Safety information, Warranties, and Regulatory information, see the pages behind the Index.

© Copyright Hewlett-Packard Company 1992-1997

Training Kit for HP 1660/70 Series Logic Analyzers

Ready, Set, Run: Easy Steps to Logic Analysis with the HP 1660/70 Series

Start Here

READY With the power off, connect Pod 1 of the analyzer to J1 on the Training Board. For the HP 1660s, Pod 1 is the top cable in the left-most position when you are facing the rear of the logic analyzer. For the HP 1670s, Pod 1 is the top cable in the right-most position when you are facing the rear of the logic analyzer.

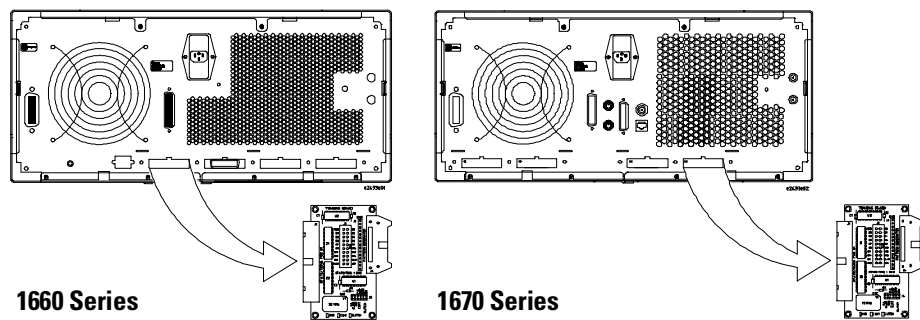

SET Turn on the analyzer by pressing the power switch near the bottom of the front panel.

The analyzer will take about 15 seconds to boot up.

RUN Press the **Run** key, near the upper right corner of the front panel. You will see the output of an 8-bit ripple counter like this:

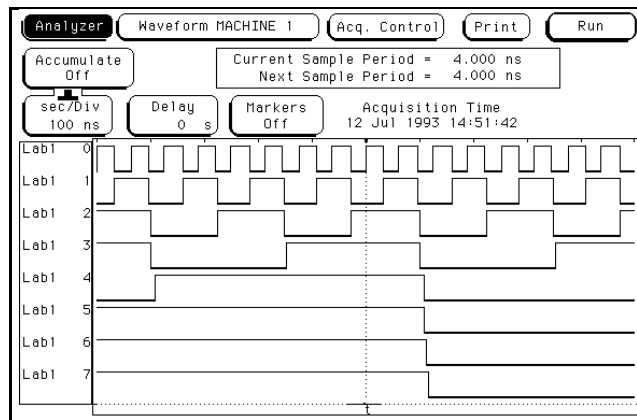

Output of the 8-bit Ripple Counter

Next

Please read the short introduction and chapter 1 before doing the exercises.

Logic Analysis made easy: a self-paced training guide

This training kit will quickly teach you how to use the HP 1660 and HP 1670 Series Logic Analyzers to get your work done. The exercises in this book will teach you how to perform basic timing and state analysis measurements and how to make more complex measurements, such as comparing two state listings, setting up complex state triggers, and making state and timing measurements simultaneously. You will also learn oscilloscope measurements if you are using a logic analyzer that has a built-in oscilloscope. You will see how easy it is to use the HP 1660 and HP 1670 Series Logic Analyzers, and at the same time, learn basic digital measurement concepts.

The exercises in this training guide are designed to work with any of the HP 1660 or HP 1670 Series analyzers with some exceptions: the exercise in chapter 5, "Mixed Mode - Correlation of State and Timing Data," will not work with an HP 1663 or HP 1664. Also, you need an analyzer with an internal oscilloscope for chapters 7 and 8. If your analyzer has an oscilloscope, you will see a "CS" after the model number. To do the exercises in chapter 9, you will need an analyzer with an internal pattern generator. If your analyzer has a pattern generator, you will see a "CP" after the model number.

Materials needed

You need the following materials to complete the exercises in this training kit:

- One HP 1660 or HP 1670 Series Logic Analyzer
- This training kit (part number HP E2433-60012)
- Probe assembly (part number HP 01650-61608) or termination adapter (part number HP 01650-63203)
- One HP 10461A TTL Data Pod

Using a Mouse

You can perform all of the exercises in this training kit using a mouse. When an instruction tells you to highlight an item and press the **Select** key, you can simply point to that item with the mouse pointer and press the left mouse button. When you want to scroll up or down a list, you can press and hold down the right mouse button and move the mouse forward and backward. Remember, to scroll a field, the field must be highlighted and have the knob icon at the top of the field.

With a mouse, some of the pop-up menus will have different appearances from the figures in this guide. For example, when you select a label and choose modify label from the pop-up menu, a keypad pop-up appears. This allows you to enter text and numbers using the mouse rather than the keypad on the front panel of the analyzer.

Configuration Disk

This kit includes a disk containing configuration files for the analyzer. The files for each chapter of the training guide set up the analyzer so you can perform an exercise. This allows you to perform the exercises in any order. You do not need to use the configuration files to do the exercises if you are working straight through this training guide, chapter by chapter.

Getting Unexpected Results

If you get lost or the results of an exercise seem to be different than this guide indicates, the system may have a previously set configuration that prevents the exercise steps from working properly. To remedy this, you can cycle the power on the analyzer and restart the exercise, or load the configuration files for the exercises you want to do.

In This Book

This book will teach you how to set up and make measurements with the HP 1660 Series and HP 1670 Series Logic Analyzers.

You can use this book in two ways: you can start at the beginning and progress chapter by chapter in a building block approach, or you can randomly access the exercises you want to do with minimum setup.

Chapter 1 contains an overview of how to use the analyzer and how to make a measurement.

Chapters 2 through 9 contain measurement exercises designed to be completed quickly and to teach you the skills you need to start making successful measurements in your work environment.

Chapter 10 contains an introduction to inverse assembly.

Chapter 11 contains information about setting the jumpers on the training board and loading the configuration files.

Chapter 12 is a reference chapter describing the training board. It includes a schematic diagram of the training board circuitry.

If you need additional details on the operation of your logic analyzer, refer to the User's Guide supplied with your system.

1 Using the Analyzer and Understanding the Measurement Process

- Using the Analyzer 1-3
- Understanding the Measurement Process 1-4

2 Introduction to Timing Analysis

- Before You Begin 2-3
- Put the Analyzer into Timing Mode 2-4
- Change a Label Name 2-5
- Modify Channel Assignments 2-6
- Define a Term for the Timing Trigger 2-7
- Set Up the Trigger Specification 2-8
- Trigger on the Term and Examine the Waveform 2-9

3 Introduction to State Analysis

- Before You Begin 3-3
- Put the Analyzer into State Mode 3-4
- Set Up the State Clock 3-5
- Change a Label Name 3-6
- Modify Channel Assignments 3-7
- Define a Term for the State Trigger 3-8
- Set Up Level 1 of the State Trigger Specification 3-9
- Set Up Level 2 of the State Trigger Specification 3-10
- Run the State Analyzer and View and Change the State Listing 3-11
- Create Symbols to Display State Data 3-12
- Create Additional Symbols 3-13
- Select and View Symbols in the State Listing 3-14

4 Comparing State Traces

- Before You Begin 4-3
- Check the Configuration 4-4
- Set Up the State Trigger Specification 4-5
- Run the Analyzer and View the State Listing 4-6
- Copy the State Listing to the Compare Reference Listing 4-7

Change the Jumper to Acquire a Different State Listing 4-8

Run the Analyzer and Find the Errors 4-9

5 Mixed Mode - Correlation of State and Timing Data

Before You Begin 5-3

Connect the Timing Analyzer 5-4

Put the Analyzer into State and Timing Modes 5-5

Change a Label Name and Modify Channel Assignments 5-6

Turn on the TCOUNT Label in the Waveform Menu 5-6

Clear the Timing Analyzer Trigger 5-7

Set Up the State Trigger Specification 5-7

Enable Time Correlation between the Timing and State Analyzers 5-8

Arm the Timing Analyzer with the State Analyzer 5-9

View the Mixed-Mode Display with Time-Correlated Markers 5-10

6 Advanced State Triggering

Before You Begin 6-3

Put the Analyzer into State Mode 6-4

Define State Trigger Terms "a" through "d" 6-5

Define State Trigger Term "e" and Range1 6-6

Add State Trigger Sequence Levels 6-7

Set Up Level 1 of the State Trigger Specification 6-8

Set Up Level 2 of the State Trigger Specification 6-9

Set Up Level 3 of the State Trigger Specification 6-10

Set Up Level 4 of the State Trigger Specification and Define a Combination Trigger Term 6-11

Check the Trigger Specification 6-13

Run the State Analyzer and View the Data 6-14

7 Using the Oscilloscope

Before You Begin 7-3

Connect the Channel 1 Oscilloscope Probe 7-4

Get the Waveform on the Display 7-5

Delete Channel 2 from the Display 7-6

Zoom and Scroll Through the Clock Waveform 7-7

- Measure the Clock Period Manually 7-8
- Measure the Clock Period with Auto Measure 7-9
- Read Voltage with the Markers 7-10

8 Triggering the Oscilloscope with the Timing Analyzer

- Before You Begin 8-3
- Set the Jumpers 8-4
- Connect the Oscilloscope Probe 8-5
- Get the Waveform on the Display 8-6
- Change the Oscilloscope Trigger 8-7
- Turn On the Timing Analyzer 8-8
- Set Up the Timing Format Menu 8-9
- Define the Timing Trigger Term "Edge 1" 8-10
- Set Up the Timing Trigger Specification 8-11
- Arm the Oscilloscope with the Timing Analyzer 8-12
- Add Oscilloscope Waveform to the Timing Waveforms 8-13
- Capture the Glitch with the Timing Analyzer and Oscilloscope 8-14
- Align the Glitch Displayed by the Oscilloscope and Analyzer 8-15

9 Using the Pattern Generator

- Before You Begin 9-3
- Connect the Pattern Generator 9-4
- Turn On the Timing Analyzer 9-5
- Change a Label Name 9-6
- Modify Channel Assignments 9-7
- Set Up the Timing Analyzer Trigger Term 9-8
- Add a Pattern Generator Label to the Timing Waveform Display 9-9
- Set Up the Pattern Generator Format Menu 9-10
- Program the Pattern Generator Output 9-12
- Add Program Lines 9-13
- Start the Pattern Generator and View the Walking Ones Pattern 9-14
- Stop the Pattern Generator 9-15

10 Introduction to Inverse Assembly

- Load the Inverse Assembler and Sample Listing 10-3
- View the Address, Data, and Status Labels 10-4
- View the Assembly Listing 10-5
- Filter the Captured Data 10-6

11 Setting the Jumpers and Loading the Configurations

- To Set the Jumpers 11-3
- To Load a Configuration File 11-5

12 All About the Logic Analyzer Training Board

- Power Source 12-2
- Circuit Description 12-2
- Jumpers 12-3
- Schematic 12-4

Using the Analyzer and
Understanding the
Measurement Process

Using the Analyzer and Understanding the Measurement Process

This chapter teaches you how to use the HP benchtop analyzer to complete the exercises in this training kit. You will also learn the general process of making a measurement.

You can refer back to this chapter whenever you have problems moving around in the interface or following the measurement process.

In this chapter you will learn how to:

- Highlight a field
- Select a field
- Scroll through lists and menus
- Understand the measurement process

Using the Analyzer

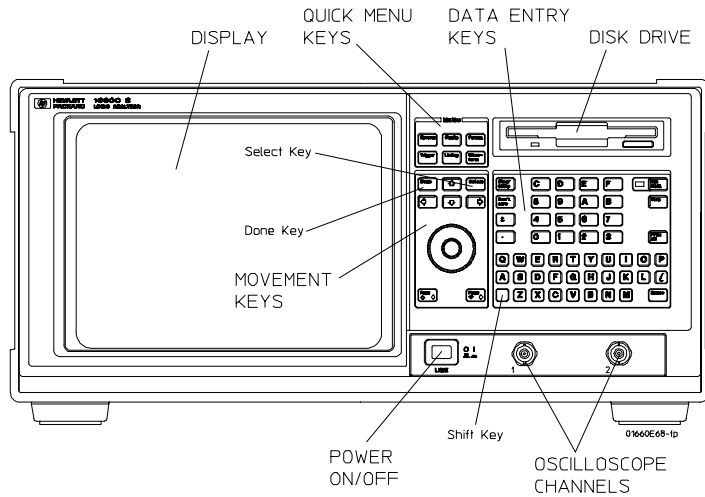

Front Panel

To Highlight a Field

Use the **movement** keys (\leftarrow , \uparrow , \rightarrow , \downarrow) to move the cursor within and between fields on the display. When the cursor is in a field, the field becomes highlighted.

To Select a Field

Use the the **movement** keys (\leftarrow , \uparrow , \rightarrow , \downarrow) to highlight the field you want to select, then press the **Select** key. The type of field highlighted will determine what will happen when the **Select** key is pressed. If the field is an option field, the **Select** key brings up an option menu, or if there are only two possible values, the **Select** key toggles the value in the field. If the highlighted field performs a function, the **Select** key starts the function. If the highlighted field is a menu choice, the **Select** key selects the menu choice.

To Scroll Through Lists and Menus

Use the knob to change the value in a field, to scroll the display, and to move the cursor in pop-up menus. If you are using a mouse, you can do the same actions by holding down the right button of the mouse while dragging.

Understanding the Measurement Process

Whenever you make a basic measurement, there is a sequence of events that you will go through. Referring back to this measurement process will help you to better understand the exercises as you complete them.

1 Map to target

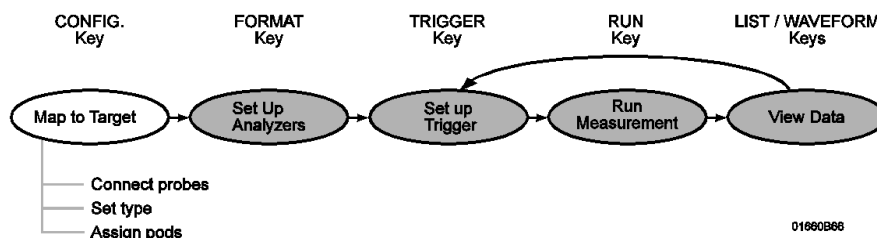

Connect probes Connect probes from the target system to the logic analyzer to physically map the target system to the channels in the logic analyzer. Attach probes to a pod in a way that keeps logically-related channels together. Remember to ground the pod. For the logic analysis lessons you will connect pods 1 and 3, for the oscilloscope lessons you will also connect an oscilloscope probe, and for the pattern generator lesson you will connect a pattern generator pod and TTL Data Pod to the training board.

Set type The analyzer has three modes: the timing analyzer mode, the state analyzer mode, and the system performance (SPA) mode. The exercises in this training kit will teach you about the first two modes, timing and state. The timing mode uses the clock within the analyzer and the state mode uses the clock supplied by the target system. When the logic analyzer is turned on, Analyzer 1 is named Machine 1 and is set to timing mode, and Analyzer 2 is off. To use state analysis, you must set the analyzer mode to state. You can use state and timing modes together, but you can't set both analyzer modes to timing.

Assign pods In the Analyzer Configuration menu, assign the connected pods to the analyzer you want to use. The number of pods on your logic analyzer depends on the model. Pods are paired and are always assigned as a pair to a particular analyzer.

2 Set up analyzers

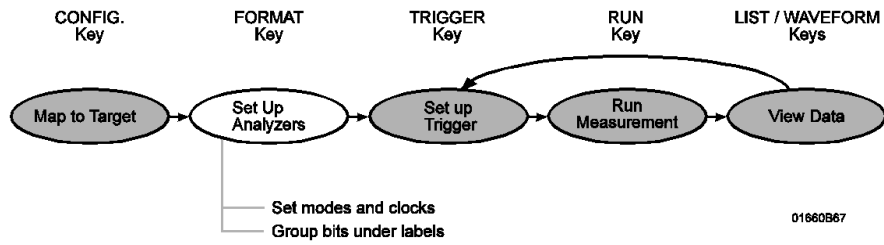

Set modes and clocks Set the state and timing analyzer modes using the Analyzer Format menu. In general, these modes trade channel count for speed or storage. If your state clock is set incorrectly, the data gathered by the logic analyzer might indicate an error where none exists.

Group bits under labels The Analyzer Format menu indicates active pod bits. You can create groups of bits across pods or subgroups within pods and name the groups or subgroups using labels.

3 Set up trigger

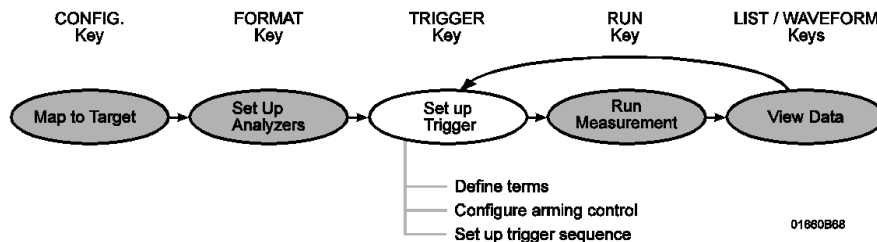

Define terms In the Analyzer Trigger menu, define trigger variables called terms to match specific conditions in your target system. Terms can match patterns, ranges, or edges across multiple labels.

Configure Arming Control Use Arming Control if:

- you want to correlate the triggers and data of both analyzers
- you want to use the analyzer to trigger an external instrument or the built-in oscilloscope
- you want to use an external instrument or the built-in oscilloscope to trigger the analyzer

Set up trigger sequence Create a sequence of steps that control what the analyzer captures. For common tasks, you can use a trigger macro to simplify the process or use the user-defined macros to loop and jump in sequence.

4 Run Measurement

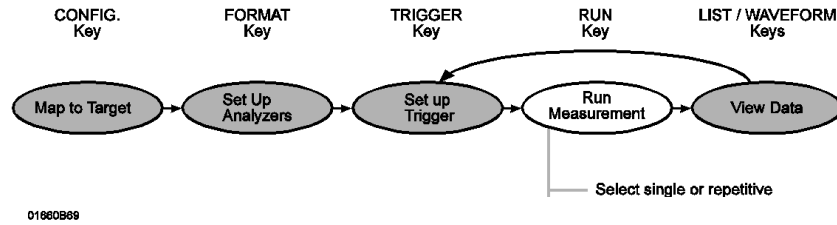

Select single or repetitive From any Analyzer or Scope menu, select the field labeled Run in the upper right corner to start the measurement, or press the Run key. A "single" run will run once, until memory is full; a "repetitive run" will run until you select Stop or until a stop measurement condition is fulfilled, which you set in the markers menu.

5 View data

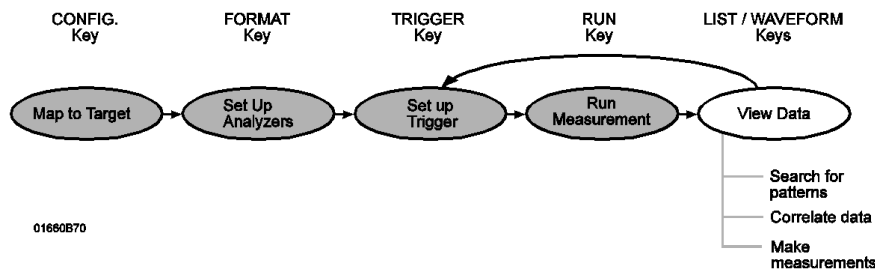

Search for patterns In both the Waveform and Listing menus you can use symbols and markers to search for patterns in your data. In the Analyzer Waveform or Analyzer Listing menu, toggle the Markers field to turn the pattern markers on and then specify the pattern. When you switch views, the markers keep their settings.

Correlate data You can correlate data by setting Count Time in your state analyzer's Trigger menu and then using interleaving and mixed display. Interleaving correlates the listings of two state analyzers. Mixed display correlates a timing analyzer waveform and a state analyzer listing, or a state analyzer and an oscilloscope waveform, or a state analyzer and both timing and oscilloscope waveforms. To correlate oscilloscope data, the oscilloscope arm mode must be set to Immediate. The System Performance Analysis (SPA) Software does not save a record of actual activity, so it cannot be correlated with either timing or state mode.

Make measurements The markers can count occurrences of events, measure durations, and collect statistics, and SPA provides high-level summaries to help you identify bottlenecks. To use the markers, select the appropriate marker type in the display menu and specify the data patterns for the marker. To use SPA, go to the SPA menu, select the most appropriate mode, fill in the parameters, and press Run.

Introduction to Timing Analysis

Introduction to Timing Analysis

Timing analysis in its simplest form means acquiring and storing data at equal time intervals. When doing timing analysis you must put the logic analyzer into timing mode. An analyzer in timing mode is referred to as a timing analyzer. The timing analyzer's time interval is controlled by a clock inside the analyzer, just like the clock in a digitizing oscilloscope. However, there are key differences between a timing analyzer and a digitizing oscilloscope. These key differences are channel count and voltage resolution. A logic analyzer typically has a large number of channels, and it displays signals at only two voltage levels, a logic high or a logic low. A digitizing oscilloscope typically has fewer channels, but it can display signals with much finer voltage resolution.

To determine whether a given sample of data should be stored and displayed as a logic high or a logic low, the timing analyzer compares the data to a threshold voltage. The threshold voltage works just like the threshold voltage in logic circuits. If the voltage level of the sampled data is above the threshold, the analyzer stores a logic high (a "1"). If the voltage level of the data is below the threshold, the analyzer stores a logic low (a "0").

The exercises in this chapter step you through the process of making a timing measurement.

In this chapter, you will:

- Put the analyzer into timing mode
- Change a label name
- Modify channel assignments
- Define a term for the timing trigger
- Set up the trigger specification
- Trigger on the term and examine the waveform

Before You Begin

1 Decide what to do next.

If you have just completed "Ready, Set, Run", go to "Change a Label Name" on page 2-5.

If you have not just completed "Ready, Set, Run" go to step 2.

2 Turn off the analyzer by pressing the power switch. Wait at least five seconds, then press the power switch again to turn on the logic analyzer.

Cycling the power defaults all system settings. This sets up the analyzer so you can perform the remaining exercises.

3 Connect Pod 1.

Connect Pod 1 of the analyzer to J1 on the Training Board. For the HP 1660s analyzer, Pod 1 is the top cable in the left-most position when you are facing the rear of the logic analyzer. For the HP1670s, Pod 1 is the top cable in the right-most position when you are facing the rear of the logic analyzer.

4 Set the jumpers as shown below.

The jumper settings of J5 on the training board for this chapter are the same as the default settings.

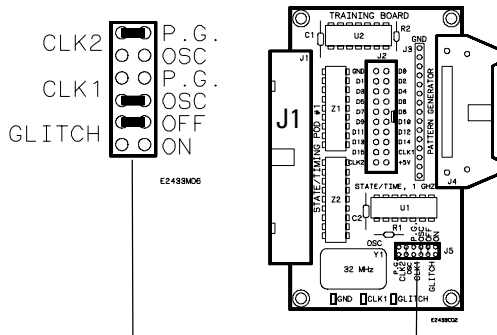

Setting the Jumpers

See Also

"To Set the Jumpers" and "To Load a Configuration File" in chapter 11 for more information.

Put the Analyzer into Timing Mode

When you first turn on the analyzer, the Configuration Menu is displayed with Analyzer 1 set to Timing mode. This is the mode the analyzer needs to be in to do timing analysis. Timing analysis uses the clock inside the analyzer to sample data at consistent time intervals.

Note If the analyzer is in Timing mode, continue on to "Change a Label Name" on the next page.

If the analyzer is not in timing mode, put it in timing mode now by following the steps below.

- 1 If you are not already in the **Configuration** menu, press the **Config MENU** key.
- 2 In the Analyzer 1 box, highlight the field to the right of **Type**, and press the **Select** key.
- 3 Highlight **Timing** in the pop-up menu, and press the **Select** key.

Unless your analyzer is an HP 1661 or an HP 1671, your Configuration Menu will look different than the one shown below because your analyzer has a different number of data pods.

The analyzer is in Timing mode.

Pod A1 has arrows on the lower eight channels and the J-clock channel, indicating that transitions across the threshold voltage are occurring on these channels.

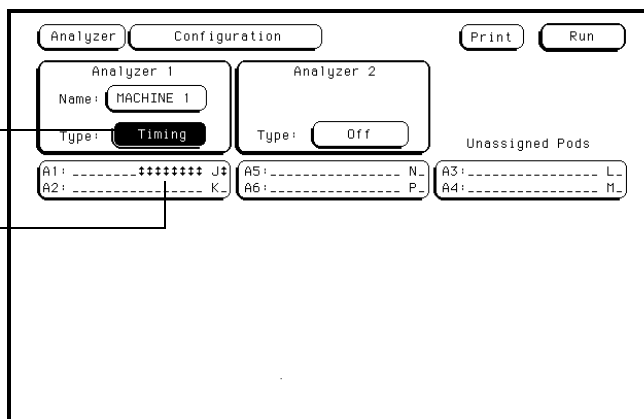

Putting the Analyzer into Timing Mode

Result The analyzer is in timing mode with activity showing on the lower eight channels and the J-clock channel of pod A1.

Change a Label Name

Labels group channels together. You can rename a label to make it more meaningful. For example, you could use the label name DATA for all of the channels that are connected to the data bus of a microprocessor.

In this exercise, you will change a label name to TCOUNT to represent the timing count data captured from the 8-bit ripple counter on the training board. The counter counts from 0 to 255 (0 to FF in hex) repetitively.

- 1 Press the **Format MENU** key.
- 2 Use the **arrow** keys (\uparrow \downarrow \leftarrow \rightarrow) to highlight **Lab1**.
- 3 Type TCOUNT using the keypad on the front panel of the analyzer.
You can use the knob or the left and right arrow keys to backspace the cursor if you need to correct a typing error.
- 4 Press the **Done** key.

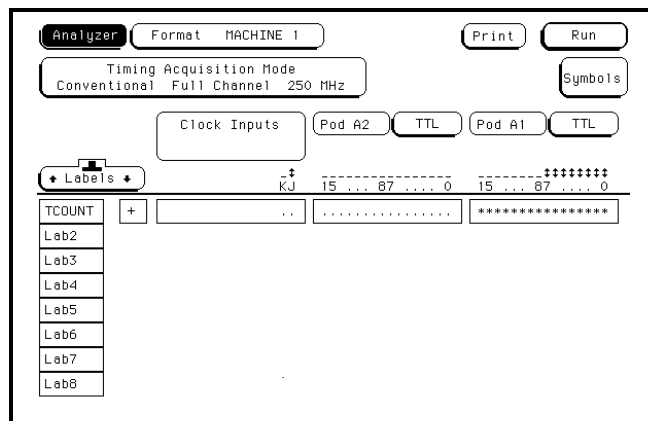

Changing a Label Name

Result

The label is now named TCOUNT, which represents timing count.

Modify Channel Assignments

In this exercise, you will assign the active bits of pod A1 to the label TCOUNT.

- 1 Using the arrow keys, highlight the field showing the 16 channels of Pod A1, to the far right of the TCOUNT label. Press the **Select** key.
- 2 Press the **Clear Entry** key to clear the default bit assignments.
- 3 Use the knob to move the cursor to channel 7 in the pop-up menu.
- 4 Press the \uparrow (up-arrow) key to put asterisks in the lower eight channel positions.
- 5 Press the **Done** key.

Pod A1 has 16 channels and is connected to the training board.

An asterisk (*) assigns a channel to a label. In this exercise, the lower eight channels are assigned to TCOUNT.

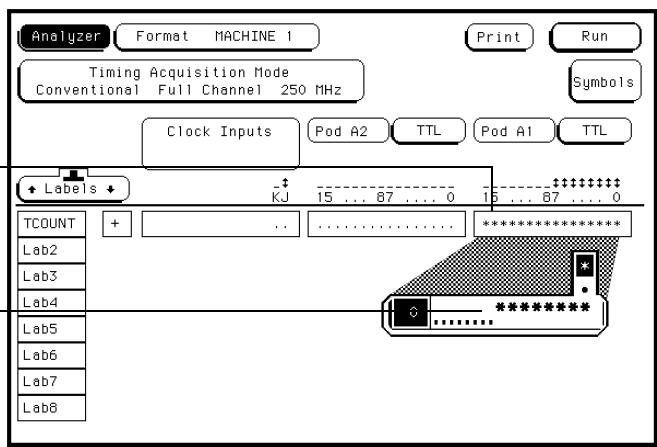

Modifying Channel Assignments

Result

The lower 8 channels of pod A1 are assigned to the label TCOUNT.

Define a Term for the Timing Trigger

For the analyzer to capture the data you want, you need to tell it what to trigger on by defining a term. Trigger terms are variables that you can use to tell the analyzer when to start recording data, what to store, and when to stop.

In this exercise, you will set up the analyzer to trigger when the counter on the training board reaches its maximum value of 255, or FF (hex). To do this, you will assign the hex value FF to term "a" of TCOUNT.

- 1 Press the **Trigger MENU** key.
- 2 Highlight the base field under TCOUNT and press the **Select** key.
- 3 Highlight **Hex** in the pop-up menu, press the **Select** key.
Hex is the default setting. Notice the other display options other than hex.
- 4 Under TCOUNT, highlight the field to the right of term **a**, enter **FF**, and press the **Done** key.

The base field specifies the type of values entered. In this exercise you selected Hex and entered the hex value FF.

A term is a variable that stores a value.

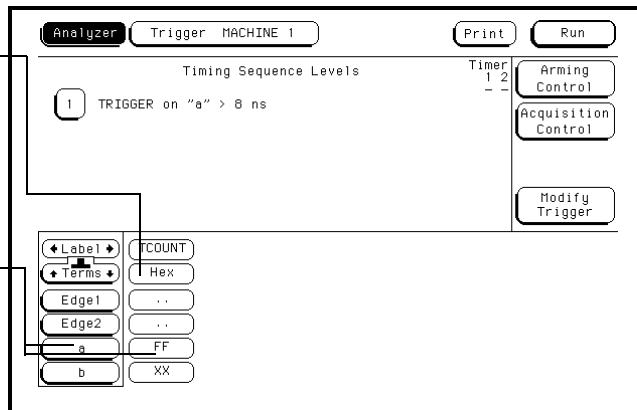

Defining a Term for the Timing Trigger

Result

TCOUNT's term "a" is assigned the value FF. The "a" term is a variable that the analyzer will trigger on once you set up the trigger specification in the next exercise.

Set Up the Trigger Specification

Using the pattern term FF that you set in the previous exercise, you will now set up the analyzer to record the data after FF occurs on the eight channel bus.

- 1 Highlight the **1** field in the Timing Sequence Levels box of the Trigger menu, and press the **Select** key.
- 2 Highlight the field to the right of **Trigger On**, and press the **Select** key.
- 3 Highlight term **a** and press the **Done** key.
- 4 Highlight the field to the right of **>**, and turn the knob to select 16 ns for the pattern duration.

Setting the duration to 16 ns ensures that the analyzer will trigger when the counter on the training board is in a stable state. A shorter duration might cause the analyzer to trigger when the counter is transitioning.

- 5 Press the **Done** key to close the Timing Sequence Level 1 pop-up menu.

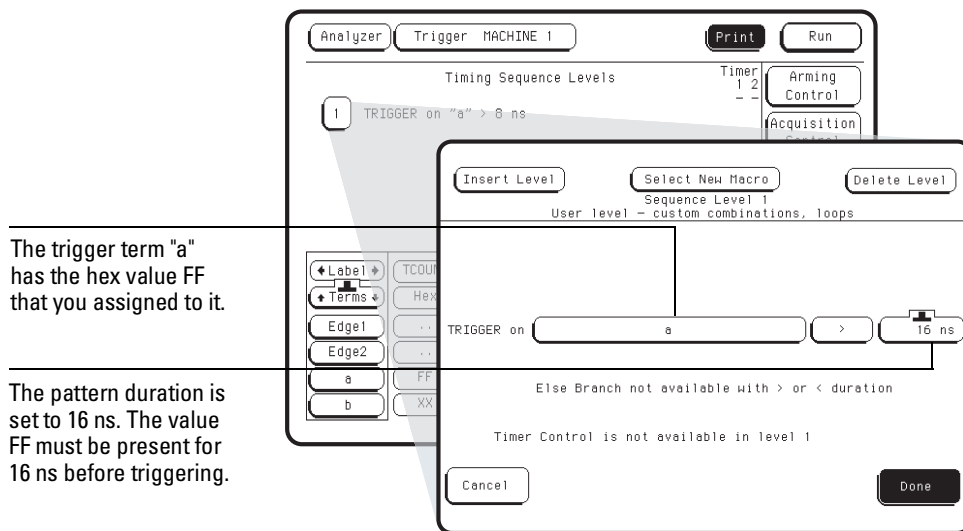

Setting Up the Trigger Specification

Result

Your trigger specification now shows: Level 1 - TRIGGER on "a" > 16 ns. The analyzer triggers when the term "a" (FF) is detected for a minimum duration of 16 ns.

Trigger on the Term and Examine the Waveform

When you press the **Run** key, the analyzer triggers on the term you set up in the previous exercise, captures the data, and then switches to the Waveform menu where the data is displayed.

- 1 Press the **Run** key.
- 2 Use the table below to examine the waveform.

To Do This:	Do This:
To scale the waveform	Highlight the sec/Div field, then turn the knob clockwise to zoom in and counter clockwise to zoom out. If you zoom out enough you can view the entire acquisition buffer.
To scroll through the waveform	Highlight the Delay field, then turn the knob in either direction to scroll through the data.
To measure a time interval	Highlight the Markers Off field, then press the Select key. Choose Time from the pop-up menu. Highlight the Trig to X field, then turn the knob to move the X marker.

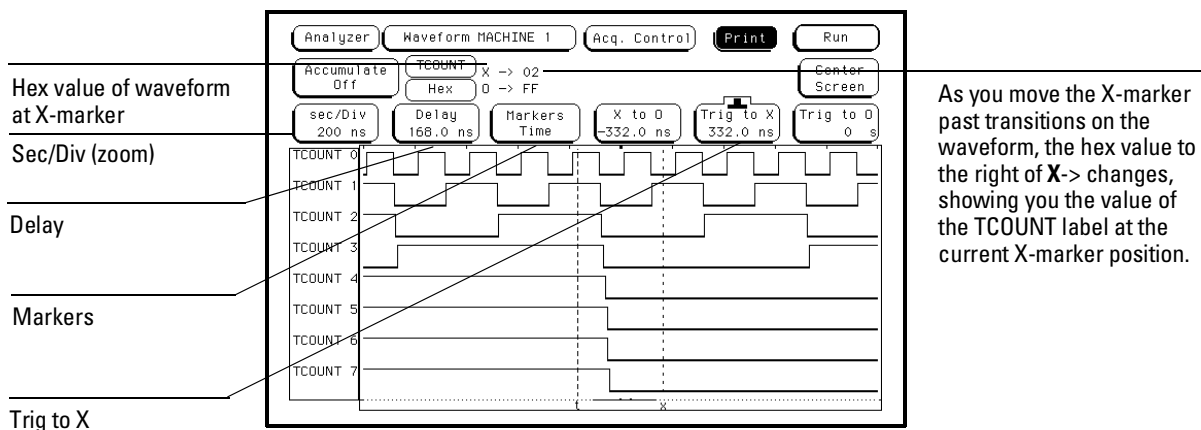

Triggering on the Term and Examining the Waveform

- 3 Highlight the **Markers Time** field. Press the **Select** key, then select **Off**.

Introduction to State Analysis

Introduction to State Analysis

State analysis in its simplest form means acquiring data and storing it when it is valid for a system under test. When doing state analysis, you must put the analyzer into state mode. The differences between state mode and timing mode are the source of the sample clock and the way the data is displayed. In state analysis, the source of the sample clock is the system under test, rather than the analyzer, and the default display is a sequential listing of logical states, rather than a waveform.

Each time the analyzer receives a state clock pulse, it samples and stores the logic state of the system under test. Just as in the timing analyzer, the state analyzer compares sampled data to a threshold voltage to determine whether it should be stored and displayed as a logic high or a logic low. The analyzer then displays the data as a sequential listing of logical states.

What makes the analyzer more than just a data acquisition instrument is its capability to acquire and store only the data that you specify. This is called data qualification. Examples of storing qualified data include storing only a certain subroutine in a program, storing all data being sent to a specified address in a system, or storing only data leading up to a system failure.

In this chapter, you will:

- Put the analyzer into state mode
- Set up the state clock
- Change a label name and modify channel assignments
- Define a term for the state trigger
- Set up the trigger specification
- Run the analyzer and view and change the state listing
- Create and view symbols

Before You Begin

1 Decide what to do next.

If you have just completed the exercises in chapter 2, go to "Put the Analyzer Into State Mode" on the next page. Otherwise, continue to step 2.

2 If you are using an HP 1660 series analyzer, load the **Analyzer** with the configuration file, CH03_60._A. If you are using an HP 1670 series analyzer, load the **Analyzer** with the configuration file, CH03_70._A.

For instructions on loading configuration files, see "To Load a Configuration File" in chapter 11.

The file defaults all system settings and sets up the analyzer as if you had just completed the exercises in chapter 2.

Unless you are using an HP 1661 or an HP 1671 analyzer, you may see an advisory message when you load the files. This is not an error. The message is displayed because these logic analyzers have a different number of data pods from the HP 1661, which was used to create the files.

3 Connect Pod 1.

Connect Pod 1 of the analyzer to J1 on the Training Board. For the HP 1660s, Pod 1 is the top cable in the left-most position when you are facing the rear of the logic analyzer. For the HP 1670s, Pod 1 is the top cable in the right-most position when you are facing the rear of the logic analyzer.

4 Set the jumpers as shown below.

The jumper settings for this chapter are the same as the default settings.

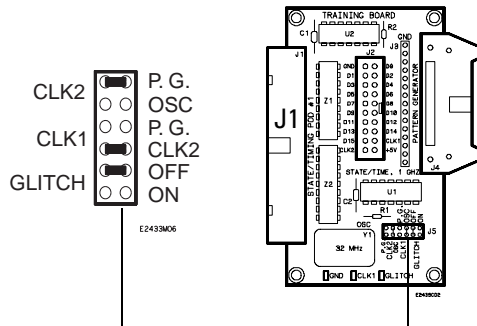

Setting the Jumpers

See Also

"To Set the Jumpers" and "To Load a Configuration File" in chapter 11 for more information.

Put the Analyzer into State Mode

To make a state measurement, you must set the analyzer to state mode. The state mode uses the clock supplied by the system under test to control when data is sampled.

- 1 Press the **Config MENU** key.
- 2 In the Analyzer 1 box, highlight the field to the right of **Type**, and press the **Select** key.
- 3 Highlight **State** in the pop-up menu, and press the **Select** key.

Unless you are using an HP 1661 or an HP 1671 analyzer, your Configuration Menu will look different than the one shown below because your analyzer has a different number of data pods than the HP 1661, which was used to create the figure.

The analyzer is in state mode.

Pod A1 has arrows on the lower eight channels and the J-clock channel, indicating that transitions across the threshold voltage are occurring on these channels.

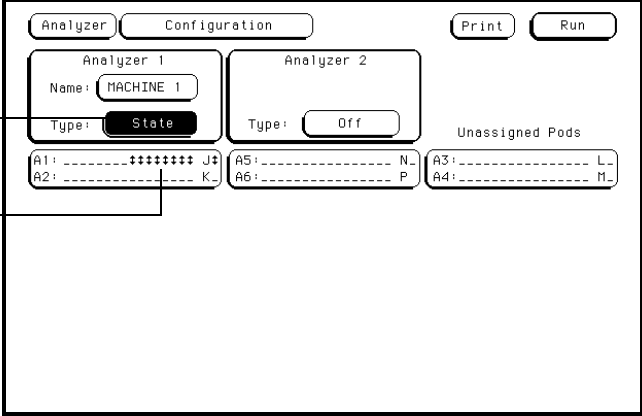

The screenshot shows a configuration menu with two analyzer boxes. Analyzer 1 is named 'MACHINE 1' and its 'Type' is set to 'State'. Analyzer 2 is set to 'Off'. Below the analyzers, there are sections for 'Unassigned Pods' and a list of pods: A1, A2, A5, A6, A3, and A4. Pod A1 is highlighted with a box, and its status is shown as 'A1: J*' and 'A2: K'. The 'J*' and 'K' labels indicate activity on the J-clock and K-clock channels, respectively. The 'A1: J*' label also indicates activity on the lower eight channels.

Putting the Analyzer into State Mode

Result

The analyzer is now in state mode showing activity on the lower eight channels and the J-clock channel of pod A1.

Set Up the State Clock

The state clock is a signal from the system under test that clocks the analyzer, causing the analyzer to sample and store data.

- 1 Press the **Format MENU** key.
- 2 Highlight the **Master Clock** field in the upper center of the display. Press the **Select** key.
 Your display will look different from the one shown in the figure below if you are using an HP 1662, 1663, 1664, or an HP 1672 analyzer. There are fewer clock lines available on these analyzers than on an HP 1661, which was used to create the figure.
- 3 Highlight the **J** field, and press the **Select** key. Highlight the ↓ (down arrow) in the pop-up menu, and press the **Select** key. If you are using an HP 1670 series analyzer, you also need to set the **L** field to **OFF**.
- 4 Press the **Done** key to close the Master Clock pop-up menu.

The down arrow represents a negative edge. The negative edge of the clock is used to get the best results from the training board.

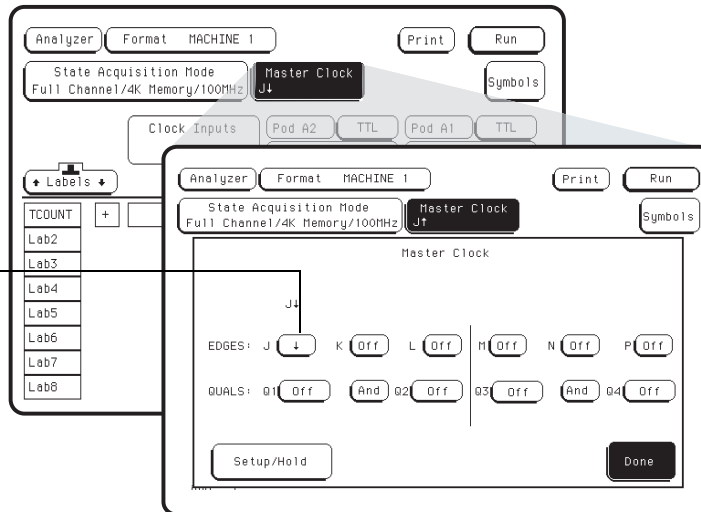

Setting Up the State Clock

Result

The analyzer will collect data on the falling edge of the J clock.

Change a Label Name

Labels group channels together. You can rename a label to make it more meaningful. For example, you could use the label name DATA for all of the channels that are connected to the data bus of a microprocessor.

In this exercise, you will change Lab2 to SCOUNT to represent the state count data. The label is named SCOUNT so that you can keep track of the counter output acquired by the state analyzer.

- 1 Highlight the label **Lab2** below the **Labels** field.
 - 2 Type SCOUNT, then press the **Done** key.
 - 3 Highlight the field labeled TCOUNT, and press the **Select** key. Highlight **Turn Label Off** in the pop-up menu, and press the **Select** key.
- If you have already performed the Introduction to Timing Analysis exercises in chapter 2, this will be the TCOUNT label, which represents timing count. Turning the label off now saves it for later use.

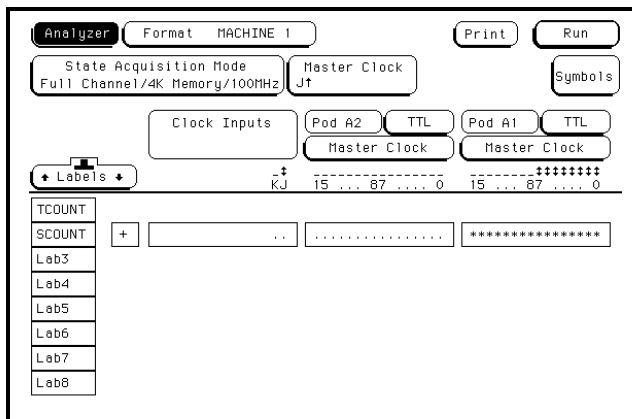

Changing a Label Name

Result

The label TCOUNT is turned off and Lab 2 is now named SCOUNT, which represents state count.

Modify Channel Assignments

In this exercise, you will assign the lower eight channels of pod A1 to the label SCOUNT.

- 1 Highlight the field showing the 16 channels of Pod A1 to the far right of the SCOUNT label. Press the **Select** key.
- 2 Using the knob, move the cursor to channel 7 in the pop-up menu. Then, press the \uparrow (up-arrow) key to put asterisks in the lower eight channel positions.
- 3 Press the **Done** key.

Pod A1 has 16 channels and is connected to the training board.

The asterisks (*) assign the lower 8 channel positions to the label SCOUNT.

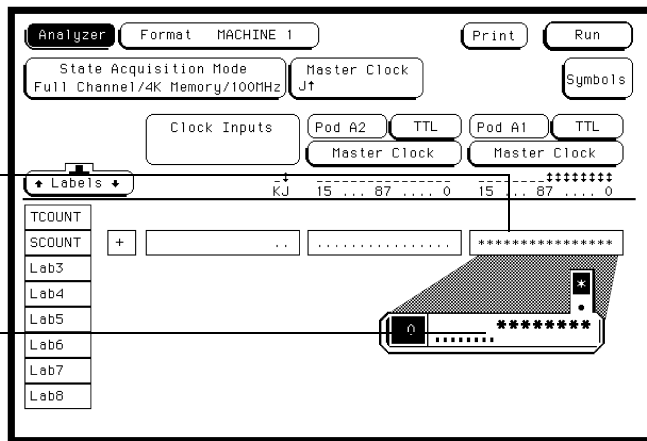

Modify the Channel Assignments

Result

The lower eight channels of pod A1 are assigned to the label SCOUNT.

Define a Term for the State Trigger

For the state analyzer to capture the data you want, you need to tell it what to trigger on by defining a term. Trigger terms are used in the trigger specification to tell the analyzer when to start recording data, what to store, and when to stop.

- 1 Press the **Trigger MENU** key.
- 2 Highlight the base field under SCOUNT, and press the **Select** key. Highlight **Hex** in the pop-up menu, and press the **Select** key.

Hex is the default setting. Notice that there are other display options other than hex.

- 3 Under SCOUNT, highlight the field to the right of **b**, enter 00, and press the **Done** key.

The "b" term is a variable to which you can assign a value.

The base field is used to specify the type of values entered.

A term is a variable that stores a value. In this exercise, you selected Hex, and entered the hex value 00 for the "b" term.

Level	Trigger	Timer
1	While storing "anystate" TRIGGER on "a" 1 time	1 2
2	Store "anystate"	--

SCOUNT

Term	Value
a	FF
b	00
c	XX
d	XX

Define a Term for the State Trigger

Result

SCOUNT's "b" term is assigned the value 00 (hex). The "b" term is a variable that the analyzer will trigger on once you set up the trigger specification in the next exercise.

Set Up Level 1 of the State Trigger Specification

In the next two exercises, you will set up the sequence of events that you want the logic analyzer to follow when triggering and storing data. In this exercise you will set Level 1 to store all data occurring before the trigger pattern is found.

- 1 Highlight the **1** field in the State Sequence Levels box of the Trigger menu. Press the **Select** key.
- 2 Highlight the field to the right of **Trigger on**, and press the **Select** key. Highlight **b** in the pop-up menu, and press the **Done** key.
- 3 Press the **Done** key to close the Sequence Level 1 pop-up menu.

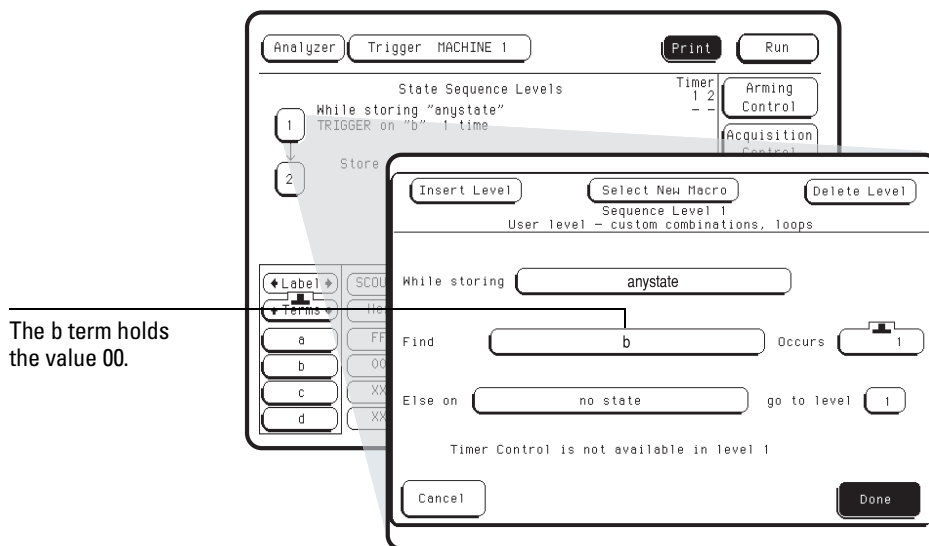

Setting Up Level 1 of the State Trigger Specification

Result

The state analyzer stores all samples, starting from the time you press run, and continuing until the trigger pattern 00 is found.

Set Up Level 2 of the State Trigger Specification

In sequence level 1 the analyzer stores data before the trigger point. For sequence level 2, you will tell the analyzer to store any data once the trigger pattern is found. This will fill the rest of the acquisition memory.

- 1 Highlight the **2** field in the State Sequence Levels box. Press the **Select** key.
- 2 Highlight the field to the right of **Store**, and press the **Select** key. Highlight **anystate** in the pop-up menu, and press the **Done** key.
- 3 Press the **Done** key to close the Sequence Level 2 pop-up menu.

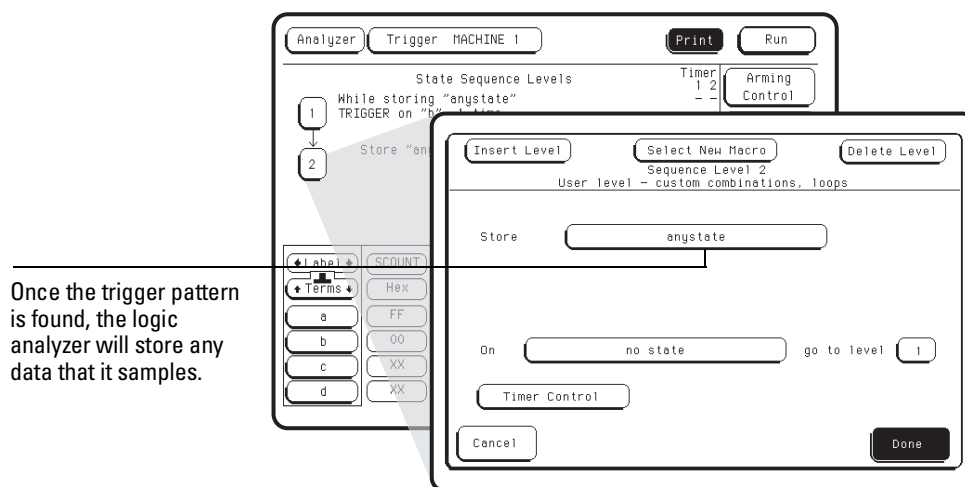

Setting Up Level 2 of the State Trigger Specification

Result

The State Trigger Specification is now:

Level 1 - While storing "anystate", TRIGGER on "b" 1 time

Level 2 - Store "anystate"

If your trigger specification does not match this one, repeat the exercises, starting with "Modify Channel Assignments" on page 3-7.

Run the State Analyzer and View and Change the State Listing

- 1 Press the **Run** key.
- 2 Observe the State Listing.

The trigger pattern 00 is centered around the zero line number, which corresponds to the trigger point you specified in the Trigger menu. The negative line numbers indicate the states stored prior to the trigger point.

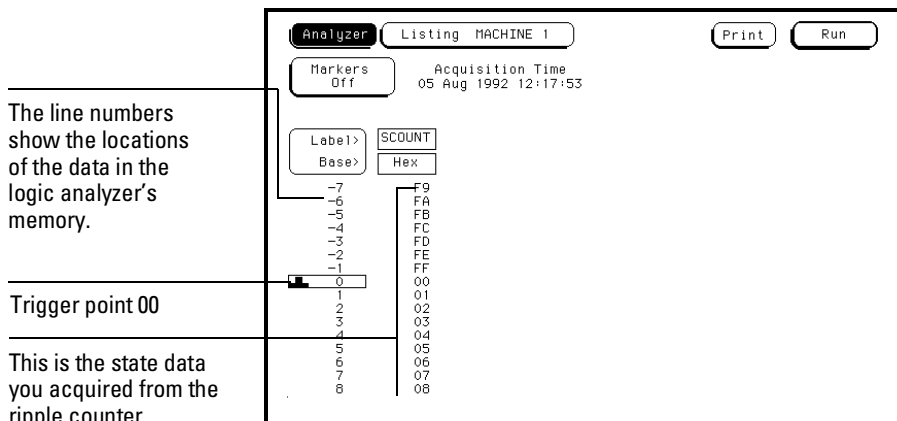

State Listing Menu

- 3 Use the table below to view and change the state listing.

To Do This:

To change the state listing display from hex to decimal

To scroll through the state listing

To page through the state listing one screen at a time

Do This:

Highlight the **Hex** field directly below the SCOUNT label, and press the **Select** key. Choose **Decimal** from the pop-up menu.

On the left-center side of the display, highlight the line number field, then turn the knob.

Press the **Page** keys below the knob.

Create Symbols to Display State Data

Symbols are used to display state data in easily understandable terms, which you define. This can make the state listing much easier to interpret. In the following exercises, you will define and display some symbols.

- 1 Press the **Format MENU** key.
- 2 Highlight the **Symbols** field, and press the **Select** key.
- 3 Highlight the **New Symbol** field below Symbol. Type "ONE" using the keypad. Press the **Done** key when you are finished typing.
- 4 Highlight the field below **Pattern/Start**. Enter 01 using the keypad. Press the **Done** key when you are finished typing.

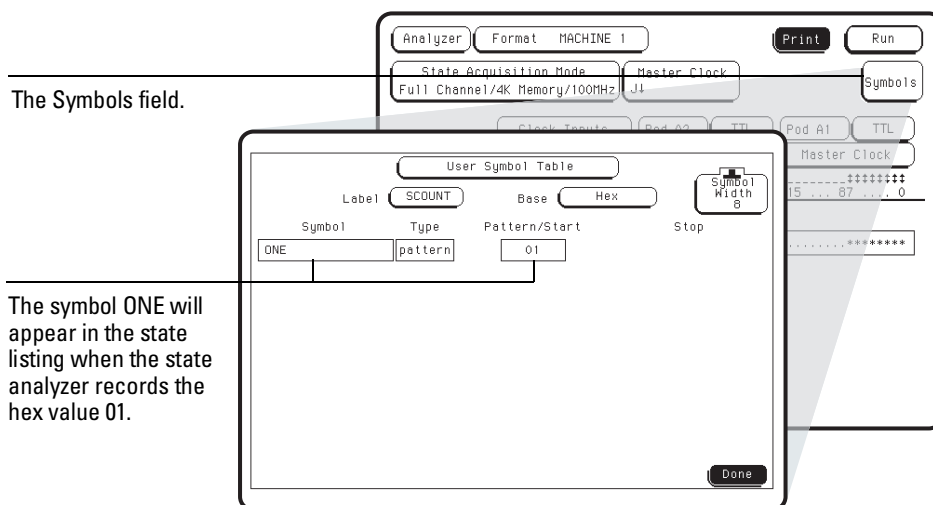

Creating Symbols to Display State Data

Result

In the state listing, the analyzer will display ONE in place of the hex number 01 when the base field is set to **Symbol**.

Create Additional Symbols

You can create as many symbols as you want. In this exercise, you will create symbols TWO and THREE for the hex values 02 and 03.

- 1 If the **Symbol Table** pop-up menu is now displayed, go to step 2. If this is not the case, highlight the **Symbols** field in the Format Menu, and press the **Select** key.
- 2 Highlight the **ONE** field below Symbol, and press the **Select** key. Highlight **Add a Symbol** in the pop-up menu, and press the **Select** key. Type TWO using the keypad. Press the **Done** key when you are finished typing.
- 3 Highlight the field to the right of the **TWO** under **Pattern/Start**. Enter 02 using the keypad. Press the **Done** key when you are finished typing.
- 4 Highlight the **TWO** field. Repeat steps 2 and 3 to create a symbol, THREE, with a pattern value of 03.
- 5 Press the **Done** key to close the Symbol Table pop-up menu.

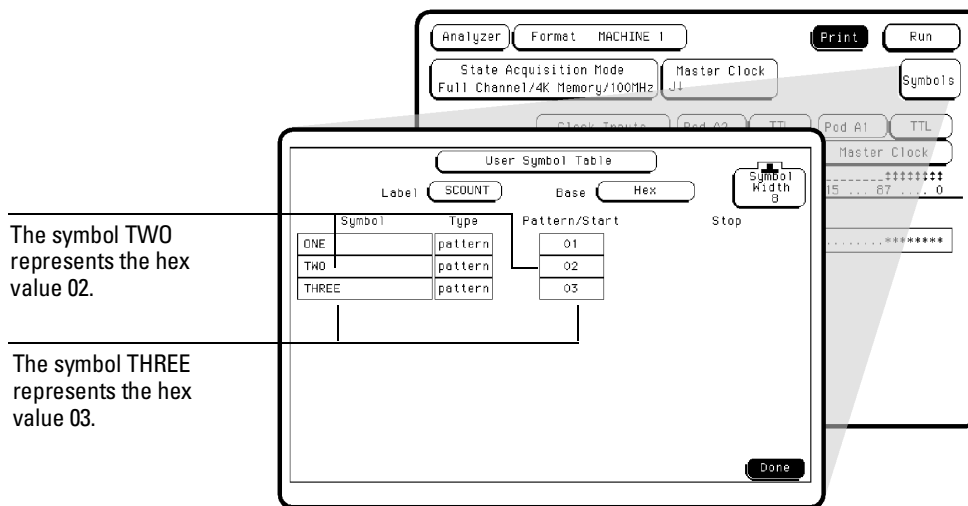

Creating Additional Symbols

Result

In the state listing, the analyzer will display TWO in place of the hex number 02, and THREE in place of the hex number 03, when the base field is set to **Symbol**.

Select and View Symbols in the State Listing

Symbols are helpful when viewing more complex state listings. For example, you might monitor a microprocessor's status lines which have specific patterns for read and write cycles. You can define symbols for these patterns. Then, wherever a read or write cycle occurs in the state listing, you will see "READ" or "WRITE," instead of a numerical representation of the patterns.

- 1 Press the **List MENU** key.
- 2 Highlight the base field under the **SCOUNT** label, and press the **Select** key. Highlight **Symbol** in the pop-up menu, and press the **Select** key. The symbols **ONE**, **TWO**, and **THREE** are displayed in the state listing in place of the numeric counts 01, 02, and 03, respectively.

The base field is set to display the data in symbol form.

Symbols **ONE**, **TWO**, and **THREE** represent data 01, 02, 03.

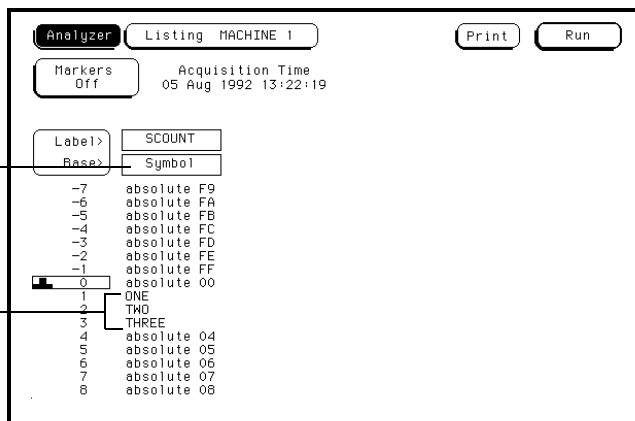

State Listing with Symbols

- 3 Select the **Symbol** field under **SCOUNT** label, and then choose **Hex** from the pop-up menu. Step 3 changes the base from decimal to hexadecimal for the rest of the exercises.

Comparing State Traces

Comparing State Traces

The State Compare feature allows you to compare two state listings. You can check if your system is executing correct states by acquiring a state listing from the system under test and comparing it to a listing that is known to be good. If there are differences between the two listings, you can use the Difference Listing feature to see where the differences occur.

In these exercises, you will run a test and store the state listing as the reference listing. Next, you will change the jumper settings and run a different test using the same trigger specification. You will then use the Difference Listing to see the differences between the two listings.

These exercises will step you through the process of using the Compare mode of the state analyzer. They are designed to use many of the same exercises as the State Analyzer Exercises in the previous chapter; therefore, the beginning exercises do not include figures or explanations. If you need this additional information on any of these common exercises, refer back to the same exercise in chapter 3, "Introduction to State Analysis."

In this chapter, you will:

- Put the analyzer into state mode
- Set up the state clock
- Change a label name and modify channel assignments
- Define a term for the state trigger
- Set up the state trigger specification
- Run the analyzer and view the state listing
- Copy the state listing to the compare reference listing
- Change the jumper to acquire a different state listing
- Run the analyzer and find the errors

Before You Begin

1 Decide what to do next.

If you have just completed the exercises in chapters 2 and 3, go to "Check the Configuration" on the next page.

If you have not just completed the exercises in chapters 2 and 3, go to step 2.

2 Load the **Analyzer** with the configuration file, CH04._A.

The file defaults all system settings and sets up the analyzer as if you just completed the exercises in chapters 2 and 3.

Unless you are using an HP 1661 or an HP 1671 analyzer, you may see an advisory message when you load the files. This is not an error. The message is displayed because these logic analyzers have a different number of data pods from the HP 1661, which was used to create the files.

3 Connect Pod 1.

Connect Pod 1 of the analyzer to J1 on the Training Board. For the HP 1660s, Pod 1 is the top cable in the left-most position when you are facing the rear of the logic analyzer. For the HP 1670s, Pod 1 is the top cable in the right-most position when you are facing the rear of the logic analyzer.

4 Set the jumpers as shown below.

The jumper settings of J5 on the training board for this chapter are the same as the default settings.

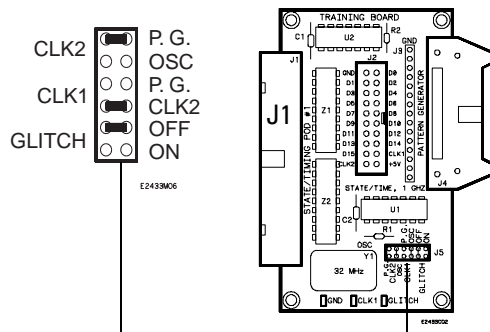

Setting the Jumpers

See Also

"To Set the Jumpers" and "To Load a Configuration File" in chapter 11 for more information.

Check the Configuration

Either you have just completed chapter 3, "Introduction to State Analysis", or you have loaded the configuration file CH_04.

- 1** If you are using an HP 1660 series analyzer go to step 2. If you are using an HP 1670 series analyzer, put the analyzer into State Compare mode before checking the configurations.

To do this, press the **Config** MENU key. In the Analyzer 1 box, highlight the field to the right of **Type**, press the **Select** key, and then choose **State Compare** from the pop-up menu.

- 2** Check the configuration.

- In the **Config** menu, Analyzer 1 is set to State mode for the HP 1660s and State Compare for the HP 1670s.
- In the **Format** menu, the **Master Clock** field is displaying **J ↓**.
- In the **Format** menu, the SCOUNT label is turned on with the lower eight channels of pod A1 assigned to it.
- In the **Trigger** menu SCOUNT's term "a" is assigned the value FF (hex).

Set Up the State Trigger Specification

When comparing two state listings, it is best to only sample the data you are interested in comparing. This will ensure that the errors you find are errors in the data you are interested in, rather than in the pretrigger data. Setting the analyzer to store "no state" before the trigger, tells the analyzer to begin capturing data after the trigger is found.

- 1 If the Trigger Menu is not already displayed, press the **Trigger MENU** key.
- 2 Highlight the **1** field in the State Sequence Levels box, and press the **Select** key.
- 3 Highlight the field to the right of **While storing**, and press the **Select** key. Highlight **no state** in the pop-up menu, and press the **Select** key.
- 4 Highlight the field to the right of **Trigger on**, and press the **Select** key. Highlight **a** in the pop-up menu, and press the **Select** key. Press the **Done** key to close the Sequence Level 1 pop-up menu.
- 5 Highlight the **2** field in the State Sequence Levels box, and press the **Select** key.
- 6 Highlight the field to the right of **Store**, and press the **Select** key. Highlight **anystate** in the pop-up menu, and press the **Select** key. Press the **Done** key to close the Sequence Level 2 pop-up menu.

Result

The trigger specification is now:

- Level 1 - While storing "no state", trigger on "a" 1 time
- Level 2 - Store "any state"

Run the Analyzer and View the State Listing

- 1 Press the **Run** key.
- 2 Observe the listing.

The State Listing is now displaying the output of the ripple counter in hexadecimal with FF (hex) at the top of the listing under the SCOUNT label. FF is at the beginning of the listing and to the right of a field in which 0 is displayed. The zero line number always displays the trigger point specified in the Trigger menu. There are no negative line numbers preceding the trigger point because the pretrigger specification was set to "While storing no state."

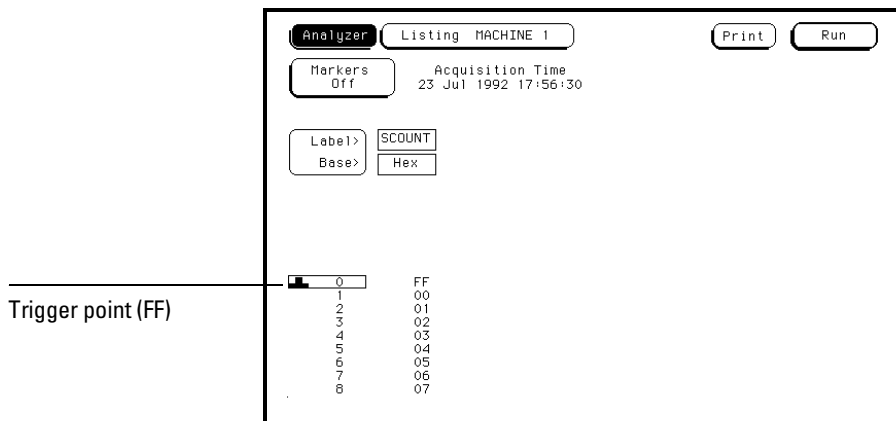

State Listing with no Pretrigger Data

Result

The state analyzer triggered on FF and began to store data, filling the acquisition memory. The data is displayed in the State Listing.

Copy the State Listing to the Compare Reference Listing

In this exercise, you will copy the state listing you acquired in the previous exercise to the reference listing so you can compare it with other listings. This feature can be used in a test environment to check that your system is executing correctly. You can acquire a state listing from the system under test and compare it to a listing that is known to be good. Any differences between the two listings can be seen using the Difference Listing feature.

- 1 Press the **List MENU** key, then choose **Compare** from the pop-up menu.
- 2 Highlight the **Copy Listing to Reference** field, and press the **Select** key.
- 3 Highlight **Execute** in the pop-up menu, and press the **Select** key.

Compare allows you to compare two state acquisitions to find differences.

Selecting this field and choosing Execute copies the listing.

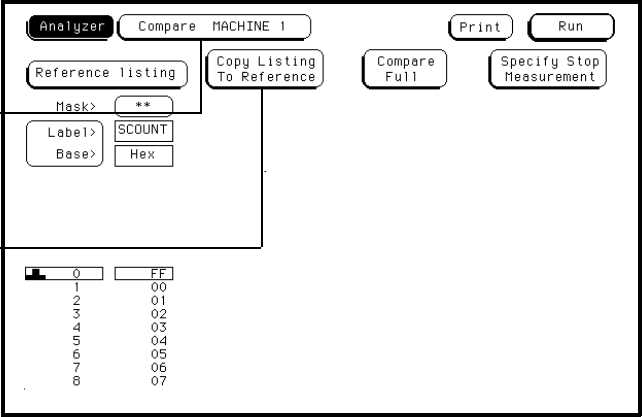

The screenshot shows the Analyzer software interface. At the top, there are buttons for 'Analyzer', 'Compare MACHINE 1', 'Print', and 'Run'. Below these are several menu options: 'Reference listing', 'Copy Listing To Reference', 'Compare Full', and 'Specify Stop Measurement'. Under 'Reference listing', there are sub-options for 'Mask>' (set to '**'), 'Label>' (set to 'SCOUNT'), and 'Base>' (set to 'Hex'). A box highlights the 'Copy Listing To Reference' option. Below the menu options is a table with two columns: a column with numbers 0 through 8, and a column with hexadecimal values FF, 00, 01, 02, 03, 04, 05, 06, and 07.

0	FF
1	00
2	01
3	02
4	03
5	04
6	05
7	06
8	07

Copying the State Listing to the Compare Reference Listing

Result

The state listing acquired in the previous exercise is now copied to the reference listing.

Change the Jumper to Acquire a Different State Listing

Changing the glitch jumper changes channel 7 of the counter so that some of the acquired states will not match the original listing. After you change the jumper, you will acquire the data again in the next exercise, then compare it to the data you copied to the Reference Listing.

- 1 Pull the glitch jumper from the pins labeled GLITCH OFF.
- 2 Push the jumper onto the pins labeled GLITCH ON.

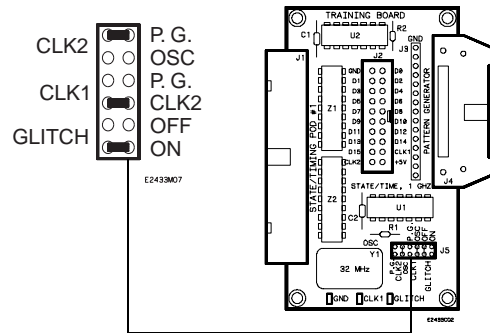

Result

The glitch jumper is changed to GLITCH ON. The next listing you acquire will be different from the one you copied to the Compare Reference listing.

Run the Analyzer and Find the Errors

Now that you have changed the jumper, you are ready to acquire a different state listing and compare it to the previous listing. In this exercise, you will switch to the Difference Listing, press the **Run** key to acquire the new state listing, and use the knob to scroll through the differences between the two listings.

- 1 Highlight the **Reference Listing** field, and press the **Select** key to switch to the **Difference Listing**.
- 2 Press the **Run** key.

The listing now shows the data that you just acquired. The analyzer compares this data to the data that you stored in the Reference Listing.

- 3 Highlight the **Find Error** field.
- 4 Use the knob to scroll through the listing. Observe the states where one of the hex numbers is white.

The white color indicates states in the new listing that do not match the reference listing. You can also type a number into the Find Error field. Find Error will jump you to that error if it exists in the listing.

The Difference Listing displays the listing you want to compare.

The Find Error field is used to scroll through the differences between the listings.

The incorrect bytes are displayed in white on your display. In this graphic, the white text is represented by the light black font.

Address	Hex Value
76	4B
77	4C
78	4D
79	4E
80	4F
81	50
82	D1
83	D2
84	D3
85	D4
86	D5
87	D6
88	D7
89	D8
90	D9
91	DA

Difference Listing

- 5 Return the Glitch Jumper on the training board to the OFF position.
- 6 Press the **List MENU** key. Choose **Listing MACHINE 1** from the pop-up menu.

Steps 5 and 6 reset the training board and the analyzer for the next exercises.

Mixed Mode - Correlation of State and Timing Data

Mixed Mode - Correlation of State and Timing Data

Mixed mode allows you to analyze a system in both state and timing modes simultaneously. A common example is using the state analyzer to capture a problem that occurs infrequently and then using the timing analyzer to analyze the problem in detail. The Mixed Mode exercises will show you how to use the mixed mode capabilities of the timing and state analyzers. These exercises are built on the timing and state exercises in chapters 2 and 3.

If your logic analyzer is an HP 1663 or HP 1664, you will not be able to perform these exercises. These analyzers have 32 data acquisition channels on two pods. All 32 channels may be assigned to either state or timing analysis, but they cannot be separated to perform mixed mode measurements.

In this chapter you will:

- Connect the timing analyzer
- Enable time-correlation between the timing and state analyzers
- Arm the timing analyzer with the state analyzer
- Run the analyzers and view the mixed mode display with time correlated markers

Before You Begin

Note

If your logic analyzer is an HP 1663 or HP 1664 you cannot perform these exercises. The HP 1663 and HP 1664 have 32 data acquisition channels on two pods. All 32 channels may be assigned to either state or timing analysis, but they cannot be separated to perform mixed-mode measurements.

1 Set the jumpers as shown below.

The jumper settings of J5 on the training board for this chapter are the same as the default settings.

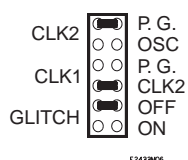

2 Decide what to do next.

If you have just completed all of the exercises in chapters 2 through 4, go to "Connect the Timing Analyzer" on the next page.

If you have not just completed all of the exercises in chapters 2 through 4, go to step 3.

3 Load the Analyzer with the configuration file, CH05._A.

The file will default all system settings and then set up the analyzer as if you had just completed all of the exercises in chapters 2 through 4.

Unless you are using an HP 1661 or an HP 1671 analyzer, you may see an advisory message when you load the files. This is not an error. The message is displayed because these logic analyzers have a different number of data pods from the HP 1661, which was used to create the files.

4 Connect Pod 1.

Connect Pod 1 of the analyzer to J1 on the Training Board. For the HP 1660s, Pod 1 is the top cable in the left-most position when you are facing the rear of the logic analyzer. For the HP 1670s, Pod 1 is the top cable in the right-most position when you are facing the rear of the logic analyzer.

See Also

"To Set the Jumpers" and "To Load a Configuration File" in chapter 11 for more information.

Connect the Timing Analyzer

Note

If you have a termination adapter, HP part number 01650-63203, connect the adapter between Pod 3 of the logic analyzer and J2 of the training board, then go to the next page to put the analyzer into state and timing modes.

1 Connect the Pod 3 connector to the probe assembly.

For the HP 1660s, Pod 3 is the top cable in the second connector from the left, as you are facing the back of the logic analyzer. For the HP 1670s, Pod 3 is the top cable in the second connector from the right, as you are facing the back of the logic analyzer.

Note

Leave Pod 1 connected to J1 of the training board. Pod 1 provides the +5 V power for the training board.

2 Connect the probe leads 0 through 7 to the pins D0 through D7 of J2.

3 Connect the probe ground lead to any pin of J3.

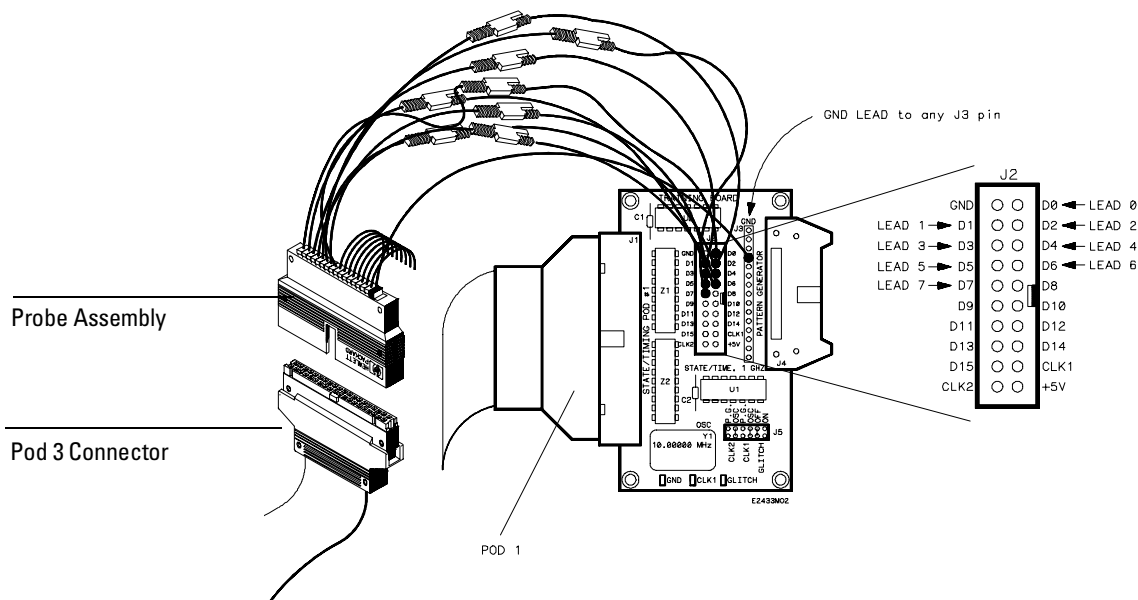

Connecting the Pod 3 Cable to the Probe Assembly

Put the Analyzer into State and Timing Modes

In this exercise you will use both the timing analyzer mode and the state analyzer mode to correlate the state and timing measurements. Pod 1 will be capturing the state measurement and Pod 3 will be capturing the timing measurement. All other pods will be unassigned.

- 1 Press the **Config** MENU key.
- 2 In the Analyzer 2 box, highlight the field to the right of **Type**, and press the **Select** key. Highlight **Timing** in the pop-up menu, and press the **Select** key.
- 3 Highlight the Pod A3/A4 field, and press the **Select** key. Highlight **Machine 2** in the pop-up menu, and press the **Select** key.
- 4 If you have any other pod pair fields other than A1/A2 and A3/A4, select each pair and choose **Unassigned** in the pop-up menu.

The screenshot shows the 'Analyzer Configuration' screen. At the top, there are buttons for 'Analyzer', 'Configuration', 'Print', and 'Run'. Below this, there are two main sections: 'Analyzer 1' and 'Analyzer 2'. 'Analyzer 1' has 'Name: MACHINE 1' and 'Type: State'. 'Analyzer 2' has 'Name: MACHINE 2' and 'Type: Timing'. Below these are pod assignment fields: 'A1: J', 'A2: K', 'A3: L', 'A4: M', 'A5:', 'A6:', 'A7: N', and 'A8: P'. To the right of these fields is a section labeled 'Unassigned Pods'. On the left side of the screen, there are two text boxes with lines pointing to the pod assignment fields. On the right side, there are two text boxes with lines pointing to the 'Unassigned Pods' section.

Analyzer 1 is in state mode with the lower 8 bits of Pod A1 and the J clock are showing activity.

Analyzer 2 in timing mode. The lower 8 bits of Pod A3 and the L clock are showing activity.

If you are using a 1660, 1661, 1670, or a 1671 set Pod A5/A6 to "Unassigned".

If you are using an HP 1660 or an HP 1670, set Pod A7/A8 to "Unassigned".

Putting the Analyzer into State and Timing Modes

Result

Analyzer 1 is in state mode with Pod 1 assigned to it. Analyzer 2 is in timing mode with Pod 3 assigned to it. The remaining pods are unassigned.

Change a Label Name and Modify Channel Assignments

- 1 Press the **Format MENU** key twice.
- 2 Highlight **Format MACHINE 2** in the pop-up menu, and press the **Select** key.
- 3 Highlight the top field under **Labels**, then type TCOUNT using the keypad. Press the **Done** key when you are finished typing.
- 4 Highlight the field showing the 16 channels of Pod A3, to the far right of the TCOUNT label. Press the **Select** key.
- 4 If there are asterisks in the pop-up, press the **Clear entry** key.
- 5 Press the \uparrow (up-arrow) key to place asterisks in the lower eight channel positions. Press the **Done** key.

Result

The top label is now the TCOUNT label with the lower eight channels of Pod A3 assigned to it.

Turn on the TCOUNT Label in the Waveform Menu

The timing data will be displayed in the waveform menu with the state data listed above. Turning the TCOUNT label on in the waveform menu tells the analyzer to display the timing data for TCOUNT.

- 1 Press the **Waveform MENU** key to display Waveform Machine2.
- 2 If the large vertical field on the left side of the display has TCOUNT 0 through TCOUNT 7 displayed, go to "Clear the Timing Analyzer Trigger" on the next page. Otherwise, continue to the next step.
- 3 Highlight the large vertical field on the left side of the display, and press the **Select** key twice.
- 4 Highlight **Insert** in the pop-up menu, and press the **Select** key.
- 5 Press the **Select** key to choose TCOUNT.
- 6 Choose **Sequential** from the next pop-up menu.

Result

The waveform menu is now set to display the timing data for TCOUNT. The sequential option inserted all channels of the label into the display.

Clear the Timing Analyzer Trigger

Clearing the timing analyzer trigger sets the specification to "don't care". By doing this, the timing analyzer will trigger as soon as it is armed by the state analyzer.

- 1 Press the **Trigger MENU** key.
- 2 Highlight the **Modify Trigger** field on the right side of the screen, and press the **Select** key.
- 3 Highlight the **Clear Trigger** field, press the **Select** key, and choose **All** from the pop-up menu.

Result

The timing analyzer trigger specification is set to a "don't care" state.

Set Up the State Trigger Specification

- 1 Press the **Trigger MENU** key. Highlight **Trigger MACHINE 1** in the pop-up menu, and press the **Select** key. The **Trigger MACHINE 1** menu is now displayed. If this is not the case, press the **Trigger MENU** key again, then choose **Trigger MACHINE 1** from the pop-up menu.
- 2 Highlight the **1** field in the State Sequence Levels box of the **Trigger** menu. Press the **Select** key.
- 3 Highlight the field to the right of **While storing**, and press the **Select** key. Highlight **anystate** in the pop-up menu, and press the **Select** key.
- 4 Press the **Done** key to close the Sequence Level 1 pop-up menu.

Result

The state analyzer trigger specification is now:

Level 1 - While storing "anystate", TRIGGER on "a" 1 time

Level 2 - Store "anystate"

The trigger term "a" is assigned the hex value FF.

Enable Time Correlation between the Timing and State Analyzers

Setting the Count to Time causes the state analyzer to store a time value, called a time stamp, for each data point that is stored in memory. When the mixed display is selected, the time stamp information is used to display the data in both the timing and state displays with the proper time relationship (correlation).

- 1 Highlight the **Count Off** field, and press the **Select** key.
- 2 In the pop-up menu, highlight the field to the right of **Count**, and press the **Select** key.
- 3 Highlight **Time** in the next pop-up menu, and press the **Select** key. Press the **Done** key to close the Count pop-up menu.

Data stored before triggering has negative time numbers, and data stored after triggering has positive time numbers.

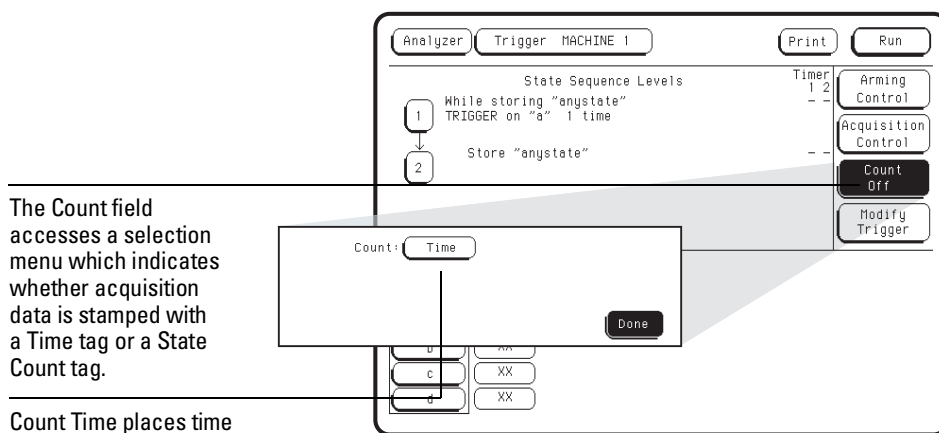

The Count field accesses a selection menu which indicates whether acquisition data is stamped with a Time tag or a State Count tag.

Count Time places time tags on all displayed data.

Enabling Time Correlation between the Timing and State Analyzers

Result

The state analyzer is set to store a time stamp for each state that is recorded. A time stamp does not have to be set for the timing analyzer because the timing analyzer automatically keeps track of time.

Arm the Timing Analyzer with the State Analyzer

Arming control sets up the order of triggering for complicated measurements that involve more than one mode, such as state and timing. Although state and timing modes involve a single analyzer, they are often referred to as the timing analyzer and the state analyzer. Arming the timing analyzer with the state analyzer allows the two modes to run simultaneously so that the data captured by both analyzers can be time-correlated.

- 1 Highlight the **Arming Control** field, and press the **Select** key.

If you are using an HP 1670 series logic analyzer, the Arming Control pop-up menu will look different because these machines do not have an oscilloscope.

- 2 Highlight **MACHINE 2** near the center of the screen, next to the **Run** field. Press the **Select** key.
- 3 Highlight the field next to **Run from**, and press the **Select** key.
- 4 Highlight **MACHINE 1** in the pop-up menu, and press the **Select** key. Press the **Done** key to close the Machine 2 pop-up menu.
- 5 Press the **Done** key to return to the Trigger Menu.

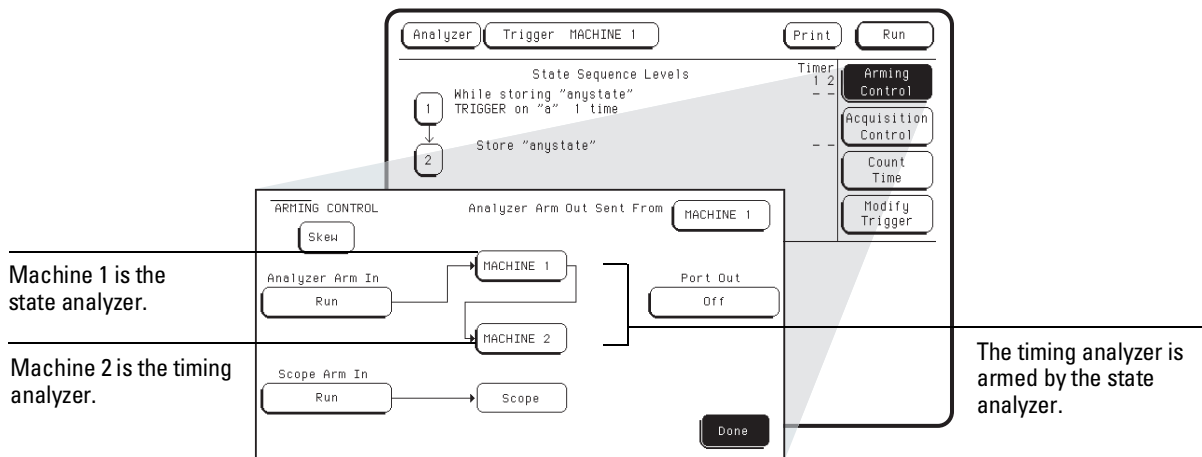

Arming the Timing Analyzer with the State Analyzer

Result

When the state analyzer (Machine 1) arms the timing analyzer (Machine 2), the timing analyzer begins to look for its own trigger condition.

View the Mixed-Mode Display with Time-Correlated Markers

When you press the **Run** key, the state analyzer triggers on the pattern FF (when all eight lines are high) and arms the timing trigger. Mixed Display displays trigger points for both the timing analyzer and the state analyzer with the state data displayed in a state listing and the timing data displayed in a timing waveform.

- 1 Press the **Run** key.
- 2 Press the **List MENU** key. Choose **Mixed Display** from the pop-up menu.
 Notice the delay between the state trigger and the timing trigger, causing the timing trigger marker to appear to the right of the FF state. This is due to the time required for the state analyzer to arm the timing analyzer.
- 3 Highlight the **Trig to X** field and rotate the knob to observe that the X markers move in both the state listing and the timing waveform displays.

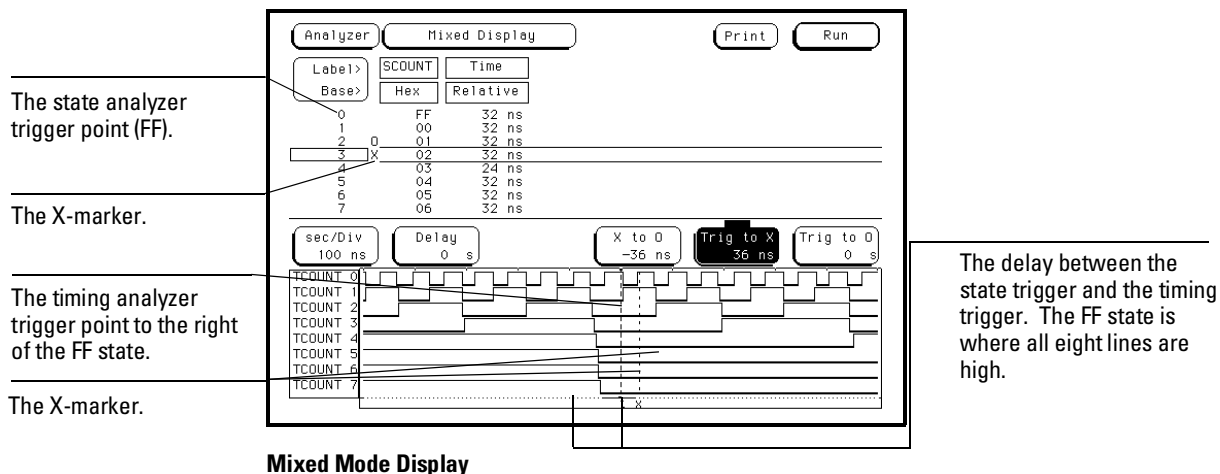

- 4 Press the **Trigger MENU** key twice.
- 5 Highlight the **Count Time** field, and press the **Select** key twice. Highlight **Off** in the pop-up menu, and press the **Select** key. Press the **Done** key.
 Steps 4 and 5 turn off the Time Count function for the next exercise.

Advanced State Triggering

Advanced State Triggering

The power of the state analyzer is in its wide range of trigger capabilities. These exercises step you through the process of using the multi-level triggering capabilities of the state analyzer.

In this chapter, you will:

- Put the analyzer into state mode
- Set up the state analyzer format
- Define individual trigger terms
- Define the range trigger term
- Add state trigger sequence levels
- Set up multiple state trigger levels
- Define a combination trigger term
- Check the trigger specification
- Run the state analyzer and view the data

Before You Begin

1 Decide what to do next.

If you have just completed all of the exercises in Chapters 2 through 5, go to "Put the Analyzer into State Mode" on the next page.

If you have not just completed all of the exercises in Chapters 2 through 5, go to step 2.

2 Load the **Analyzer** with the configuration file, CH06._A.

The file defaults all system settings and sets up the analyzer as if you just completed all of the exercises in Chapters 2 through 5.

Unless you are using an HP 1661 or an HP 1671 analyzer, you may see an advisory message when you load the files. This is not an error. The message is displayed because these logic analyzers have a different number of data pods from the HP 1661, which was used to create the files.

3 Connect Pod 1.

Connect Pod 1 of the analyzer to J1 on the Training Board. For the HP 1660s, Pod 1 is the top cable in the left-most position when you are facing the rear of the logic analyzer. For the HP 1670s, Pod 1 is the top cable in the right-most position when you are facing the rear of the logic analyzer.

4 Set the jumpers as shown below.

The jumper settings of J5 on the training board for this chapter are the same as the default settings.

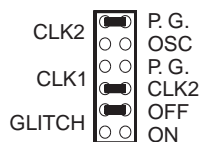

E2438M06

See Also

"To Set the Jumpers" and "To Load a Configuration File" in chapter 11 for more information.

Put the Analyzer into State Mode

- 1 Press the **Config** MENU key.
- 2 In the Analyzer 2 box, highlight the field to the right of **Type**, and press the **Select** key. Highlight **Off** in the pop-up menu, and press the **Select** key.
- 3 In the Analyzer 1 box, highlight the field to the right of **Type**, and press the **Select** key. Highlight **State** in the pop-up menu, and press the **Select** key.

Result

The analyzer is now in state mode. The lower eight channels and the J-clock channel of pod A1 are showing activity.

Define State Trigger Terms "a" through "d"

In the following exercises, you will set up the analyzer to check for and store a complex sequence of states before it triggers. While the analyzer checks for these states, it will store only selected states that you define. As in chapter 3, you will define your trigger terms first, then use these terms to define a sequence of events. In this case, the sequence will be made up of states of the ripple counter on the training board. You can use this same method to monitor any state sequence, such as subroutine calls or read and write cycles of a microprocessor.

- 1 Press the **Trigger MENU** key.
- 2 Highlight the base field below SCOUNT, and press the **Select** key. Highlight **Decimal** in the pop-up menu, and press the **Select** key.
- 3 Under SCOUNT, highlight the field to the right of the **a** term.
- 4 Enter 011 and then press the **Done** key.
- 5 Repeat steps 3 and 4 to enter 022, 033, and 044 in terms **b**, **c**, and **d**, respectively.

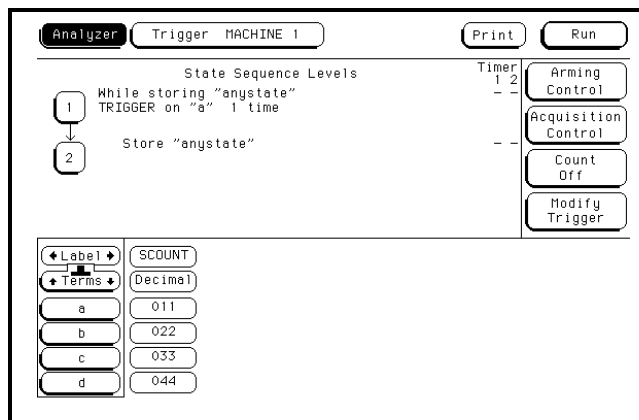

Defining State Trigger Terms "a" through "d"

Result

The trigger terms "a", "b", "c", and "d" are assigned the decimal values 011, 022, 033, and 044.

Define State Trigger Term "e" and Range1

The trigger term "e" stores one value. The Range1 term, however, can store a range of values. Storing a range of values is useful when you are looking to store the data of a subroutine or procedure.

- 1 Turn the knob clockwise to display the **e** term in the bottom left corner of the display. Under **SCOUNT**, highlight the field to the right of **e**. Enter 059 using the keypad. Press the **Done** key.
- 2 Turn the knob until the Range1 term is displayed. Highlight the field to the right of **upper** and enter 058 using the keypad. Press the **Done** key.
- 3 Highlight the field to the right of **lower** and enter 050 using the keypad. Press the **Done** key.

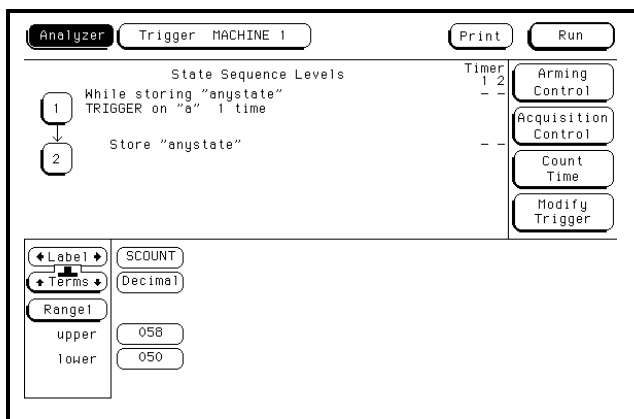

Defining State Trigger Terms "e" and Range1

Result

The trigger term "e" is assigned the decimal value 059, and Range1 is assigned decimal values 050 through 058.

Add State Trigger Sequence Levels

You tell the analyzer what data to capture by setting the sequence specification. In this exercise, your sequence specification will have five sequence levels.

- 1 Highlight the **1** field in the State Sequence Levels box of the Trigger menu. Press the **Select** key.
- 2 Highlight the **Insert Level** field, and press the **Select** key. Highlight **Before** in the pop-up menu, and press the **Select** key.
- 3 In the Trigger Macro Library, use the knob to highlight "**1. User level - custom combinations, loops,**" then press the **Done** key.
Custom triggering is set up by selecting the user level. In the Trigger Macro library, trigger macros are also available for common trigger applications.
- 4 Repeat step 2 and 3 two more times. After inserting these two levels, press the **Done** key to close the Sequence Level 1 pop-up menu.

Selecting "Before" inserts a new sequence level before the sequence level 1.

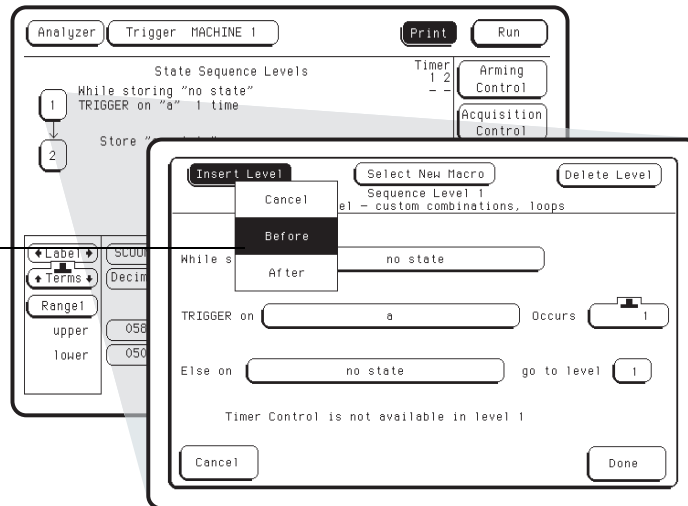

Adding State Trigger Sequence Levels

Result

You now have Sequence Levels 1 through 5. You can scroll through the sequence levels by highlighting "State Sequence Levels" centered above sequence level 1 and turning the knob.

Set Up Level 1 of the State Trigger Specification

The first term you will look for and store before triggering is term "a", which stores the value 011. Because you are only interested in 011, you will set the "While Storing" field to "no state" so that no other data is stored.

- 1 Highlight the **1** field in the State Sequence Levels box of the Trigger menu. Press the **Select** key.
- 2 In the pop-up menu, highlight the field to the right of **While storing**, and press the **Select** key. Highlight **no state** in the pop-up menu, and press the **Select** key.
- 3 Highlight the field to the right of **Find**, and press the **Select** key. Highlight **a** in the pop-up menu, and press the **Select** key.
- 4 Press the **Done** key to close the Sequence Level 1 pop-up menu.

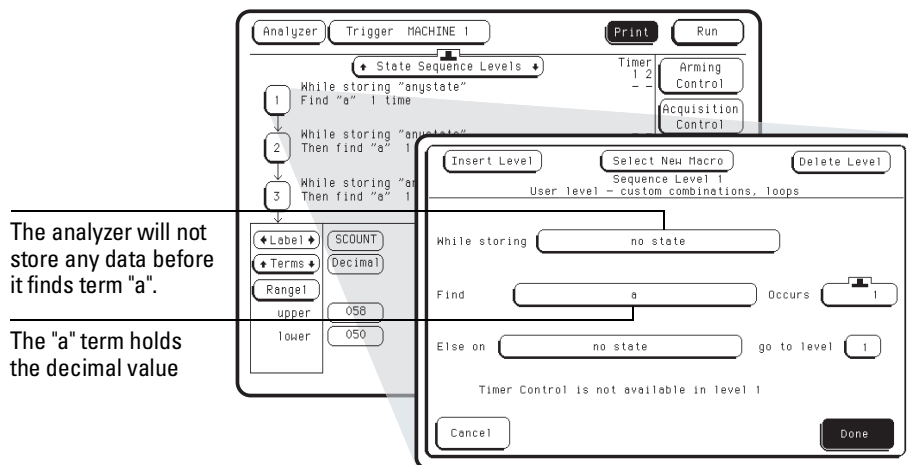

Setting Up Level 1 of the State Trigger Specification

Result

Sequence Level 1 is set to find and store only term "a" the first time it occurs.

Set Up Level 2 of the State Trigger Specification

The second term you will look for is the range of values 050 through 058, which you defined as "In_Range1". While you are storing these values, you also want to find and store term "e" with the value 059.

- 1 Highlight the **2** field in the State Sequence Levels box of the Trigger menu. Press the **Select** key.
- 2 Highlight the field to the right of **While storing**, and press the **Select** key. Highlight **In_Range1** in the pop-up menu, and press the **Select** key.
- 3 Highlight the field to the right of **Then find**, and press the **Select** key. Highlight **e** in the pop-up menu, and press the **Select** key.
- 4 Press the **Done** key to close the Sequence Level 2 pop-up menu.

The image shows a screenshot of a software interface for setting up a state trigger. The main window is titled "Analyzer Trigger MACHINE 1" and contains a "State Sequence Levels" section with three levels. Level 2 is selected, and a pop-up menu is open for "Sequence Level 2". The pop-up menu has fields for "While storing" (set to "In_Range1"), "Then find" (set to "e"), and "Else on" (set to "no state"). There are also buttons for "Timer Control", "Cancel", and "Done".

In_Range1 tells the analyzer to store the values 050 through 058.

While storing In_Range1, the analyzer looks for and stores "e" one time.

Setting Up Level 2 of the State Trigger Specification

Result

Sequence Level 2 is set to store the "In_Range1" values 050 through 058 and then find and store the term "e" value 059.

Set Up Level 3 of the State Trigger Specification

The third term you want to find and store is term "b" with the value 022. Because you only want to store this value, you set the "While Storing" field to "no state".

- 1 Highlight the **3** field in the State Sequence Levels box of the Trigger menu. Press the **Select** key.
- 2 Highlight the field to the right of **While storing**, and press the **Select** key. Highlight **no state** from the pop-up menu, and press the **Select** key.
- 3 Highlight the field to the right of **Then find**, and press the **Select** key. Highlight **b** from the pop-up menu, and press the **Done** key.
- 4 Press the **Done** key to close the Sequence Level 3 pop-up menu.

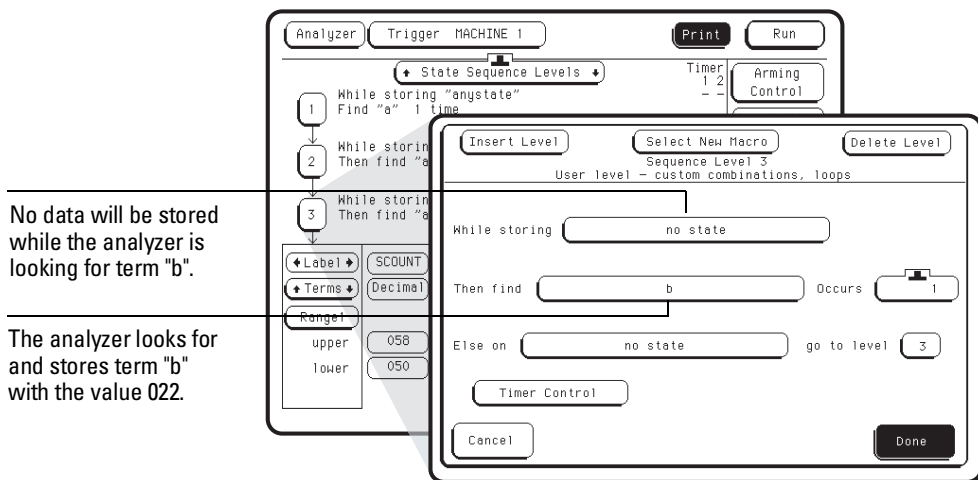

Setting Up Level 3 of the State Trigger Specification

Result

Sequence Level 3 is set to find and store only term "b" the first time it occurs.

Set Up Level 4 of the State Trigger Specification and Define a Combination Trigger Term

In Sequence Level 4 you will store a combination of values while looking for the trigger term "e". A combination term, is a logical combination of other terms, using boolean logic operators like AND and OR. In this exercise, you will define the combination of terms "c" or "In_Range1" or "d". These three terms are ORed together so that one, two, or all three of the terms could be stored.

- 1 Turn the knob clockwise to display sequence levels 3, 4, and 5.
- 2 Highlight the **4** field in the State Sequence Levels box of the Trigger menu. Press the **Select** key.
- 3 Highlight the field to the right of **While storing**, and press the **Select** key. Highlight **Combination** in the pop-up menu, and press the **Select** key.
- 4 In the combination pop-up menu, highlight **c**, and press the **Select** key. Highlight **ON** in the pop-up menu, and press the **Select** key.
- 5 Highlight **In_Range1**, and press the **Select** key. Highlight **In** in the pop-up menu, and press the **Select** key.
- 6 Highlight **d** and press the **Select** key. Highlight **ON** in the pop-up menu, and press the **Select** key.

Note the "Current Qualifier" display in the top right corner of the screen. Your qualifier is now "c + in_range1 + d."

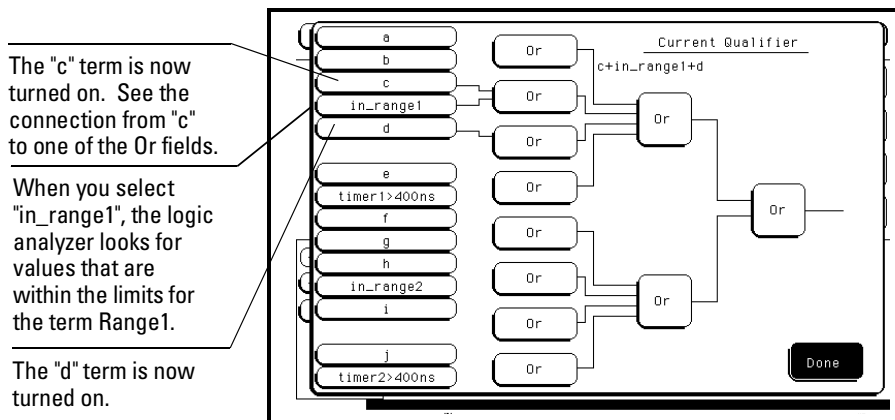

Defining a Combination Trigger Term

Advanced State Triggering Set Up Level 4 of the State Trigger Specification and Define a Combination Trigger Term

- 7 Press the **Done** key once to close the Combination Term pop-up menu.
- 8 Highlight the field to the right of the **TRIGGER on** field, and press the **Select** key. Highlight **e** in the pop-up menu, and press the **Select** key.
- 9 Press the **Done** key to close the Sequence Level 4 pop-up menu.

The analyzer stores one, two, or all three of these terms while looking for term "e".

The analyzer looks for and stores term "e" with the value 059.

The screenshot shows the 'Analyzer' window for 'Trigger MACHINE 1'. It displays a state sequence diagram with levels 3, 4, and 5. Level 3 is 'While storing "no state" Then find "a"', level 4 is 'While storing "a" TRIGGER on "e"', and level 5 is 'Store "a"'. A pop-up menu for 'Sequence Level 4' is open, showing 'User level - custom combinations, loops'. The 'While storing' field contains 'c+In_Range1+d', the 'TRIGGER on' field contains 'e', and the 'Occurs' field is set to 1. The 'Else on' field contains 'no state' and 'go to level' is set to 4. The 'Timer Control' field is empty. The 'Done' button is highlighted.

Setting Up Level 4 of the State Trigger Specification

Result

Sequence Level 4 is set to store the combination of values "c+In_Range1+d." before finding and triggering on term "e".

Check the Trigger Specification

Now you can check the trigger specification by scrolling through the five sequence levels. You did not have to set up Level 5 because you want the analyzer to trigger and store "anystate". The last level of a trigger specification has this as the default.

- 1 Highlight the "State Sequence Levels" field centered above the sequence specification.**
- 2 Turn the knob clockwise to scroll down through the sequence levels.**

Your trigger specification should look like the one below:

- Level 1 - While storing "no state"; Find "a" 1 time
- Level 2 - While storing "In_Range1"; Then find "e" 1 time
- Level 3 - While storing "no state"; Then find "b" 1 time
- Level 4 - While storing "c + In_Range1 + d" ; TRIGGER on "e" 1 time
- Level 5 - Store "anystate"

If your trigger specification is not correct, repeat the appropriate exercises on the previous pages to correct the sequence levels that do not match.

Run the State Analyzer and View the Data

- 1 Press the **Run** key.
- 2 Highlight the base field below the SCOUNT label, and press the **Select** key. Highlight **Decimal** in the pop-up menu, and press the **Select** key.
- 3 Highlight the line number field on the left side of the display. Scroll the listing to the beginning by turning the knob counter clockwise.

Result

Your listing now matches the data under the SCOUNT label in the figure below. The first state in your listing is decimal 011 which is term "a." You then see the Range1 values (050 - 058), followed by terms "e," "b," and the combination term "c + in_range1 + d". At line number 0, you see the trigger term "e," followed by "anystate".

State Listing Showing Your Defined Terms

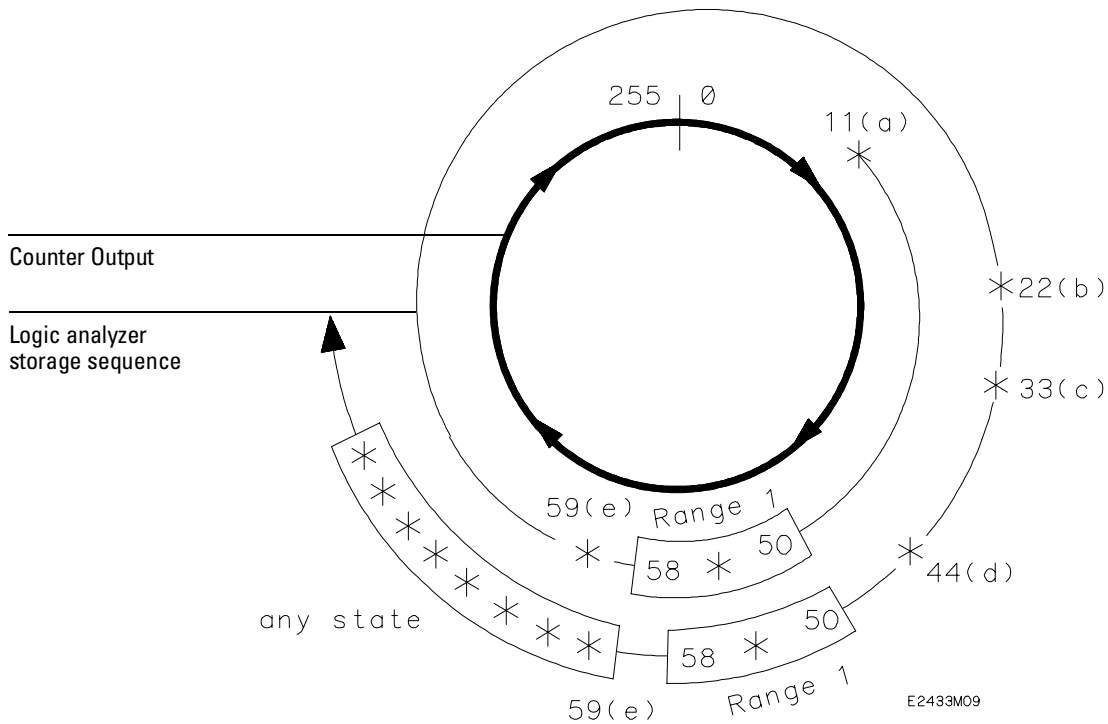

Ripple Counter Output and Stored States

The figure above shows you the output of the ripple counter (the circle) and the sequence of qualification and storage that the state analyzer performed. The asterisks indicate when the state analyzer found and stored valid terms in this example. All states were initially excluded, using the "no state" term. First the "a" term was stored. Next, states that were within the specified Range1 term (50 - 58) were stored, while the analyzer searched for an occurrence of term "e." Once the remaining terms and range were found in the specified sequence, the state analyzer stored everything (anystate) until its acquisition memory was filled.

With multi-level state triggering, you specify the data to be stored by the state analyzer. If you are debugging software, you can store or exclude certain program lines or entire blocks of code, such as subroutines.

Using the Oscilloscope

Using the Oscilloscope

These exercises show you how to use the oscilloscope inside the analyzer. If you are using an HP 1660CS, HP 1661CS, HP 1662CS, or an HP 1663CS analyzer, you have a built in oscilloscope.

You will start by using the Autoscale feature to set up the oscilloscope. You will also use the Auto Measure feature to measure the period of the training board clock signal.

In this chapter, you will:

- Connect the channel 1 oscilloscope probe
- Get the waveform on the display with Autoscale
- Delete the unused channel from the display
- Zoom and scroll through the clock waveform
- Measure the clock period manually
- Measure the clock period with Auto Measure
- Read the pulse voltage with the markers

Before You Begin

1 Decide what to do next.

If you have just completed the exercises in chapters 2 through 6, go to "Connect the Channel 1 Oscilloscope Probe" on the next page.

If you have not just completed the exercises in chapters 2 through 6, go to step 2.

2 Load the configuration files CH07._A and CH07._B.

When loading these files, you must set the analyzer to load **All**, because you are loading two types of files for this exercise. Setting the analyzer to load **Analyzer** like you did in previous exercises, will only load CH07._A properly.

The files will default all system and oscilloscope settings. If you need instructions to load the configuration files, refer to chapter 11, "To Load a Configuration File."

3 Connect Pod 1.

Connect Pod 1 of the analyzer to J1 on the Training Board. For the HP 1660s, Pod 1 is the top cable in the left-most position when you are facing the rear of the logic analyzer. Pod 1 must be connected in order to supply the +5 V power for the training board.

4 Set the jumpers as shown below.

The jumper settings of J5 on the training board for this chapter are the same as the default settings. For more information about setting the jumpers, refer to chapter 11, "To Set the Jumpers."

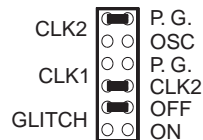

E2439M06

Connect the Channel 1 Oscilloscope Probe

- 1 Connect the oscilloscope probe to channel 1 on the front panel of the analyzer.
- 2 Connect the probe tip to the test point labeled "CLK 1" on the Logic Analyzer Training Board.
- 3 Connect the probe ground lead to the test point labeled "GND" on the Logic Analyzer Training Board.

Note

Connect pod 1 to J1 of the training board. Pod 1 must be connected to supply the +5 V power for the training board.

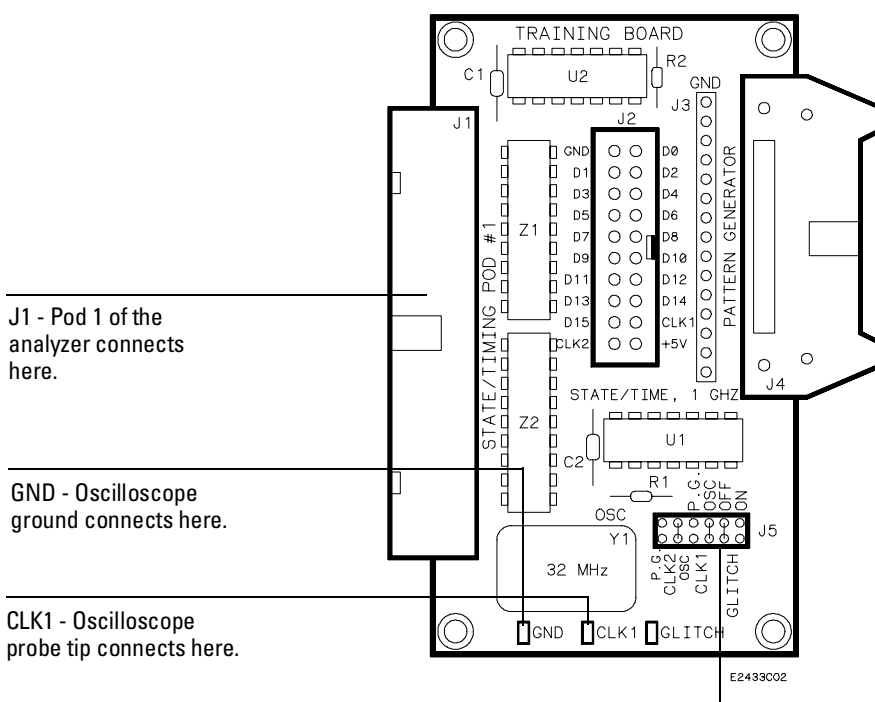

Connecting the Channel 1 Oscilloscope Probe

Get the Waveform on the Display

The Autoscale feature automatically scales the vertical sensitivity and the horizontal time base of the oscilloscope to provide a display of the waveform. This simplifies the setup of the oscilloscope and is very helpful when the amplitude and period of a signal are unknown.

- 1 Press the **Config** key.
- 2 Highlight the field in the top, left corner of the display and press the **Select** key. Highlight **Scope** in the pop-up menu, and press the **Select** key.
- 3 Highlight the **Autoscale** field and press the **Select** key. Highlight **Continue** in the pop-up menu, and press the **Select** key.

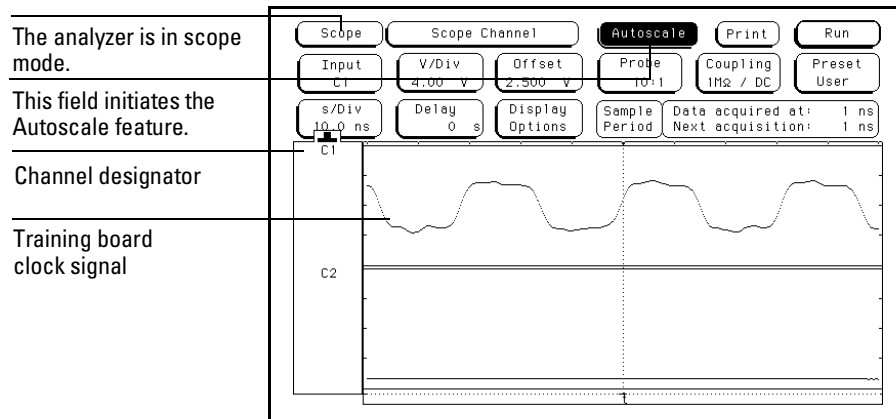

Getting the Waveform on the Display

Result

The training board clock signal is automatically scaled and is displayed in channel C1.

Delete Channel 2 from the Display

You can delete the unused channels to get more display space.

- 1 Highlight the bar on the left side of the waveform area.
- 2 Using the knob, place the cursor on the channel 2 designator (C2), then press the **Select** key.
- 3 Select **Delete** from the pop-up menu.

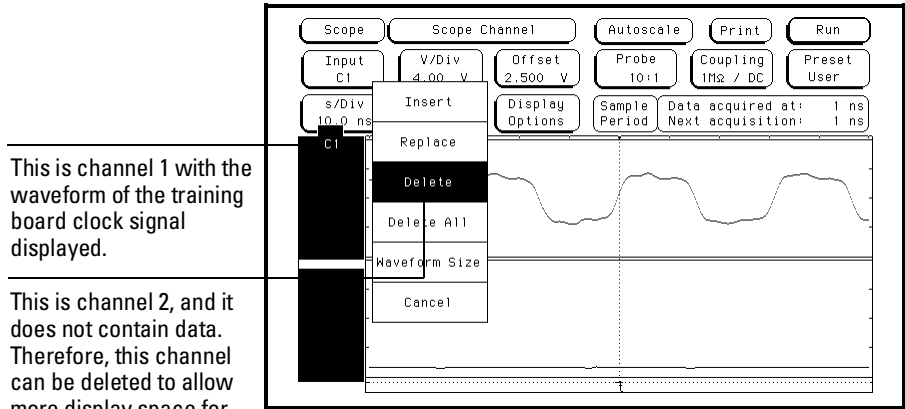

This is channel 1 with the waveform of the training board clock signal displayed.

This is channel 2, and it does not contain data. Therefore, this channel can be deleted to allow more display space for channel 1.

Deleting Channel 2 from the Display

Result

The unused channel 2 is deleted from the display. The waveform for channel 1 occupies the entire display.

Zoom and Scroll Through the Clock Waveform

You can use the s/Div field to set the time scale on the horizontal axis of the display from 1 ns/div to 5 s/div, and you can use the Delay field to scroll through the waveform.

- 1 Highlight the **s/Div** field.
- 2 Rotate the knob clockwise to expand the clock waveform. Rotate the knob counter clockwise to compress the waveform.
- 3 Highlight the **Delay** field.
- 4 Rotate the knob in both directions to scroll the clock waveform.

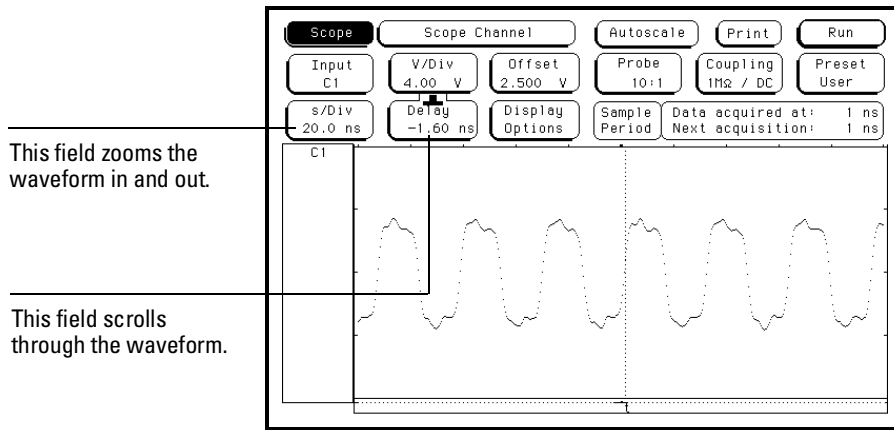

Expanding and Scanning the Clock Waveform

Measure the Clock Period Manually

Time and voltage measurements can be made manually by turning the T Markers field on.

- 1 Press the **Marker** MENU key. **Marker** is printed in white on the MENU key.
- 2 Highlight the **T Markers Off** field and press the **Select** key. Highlight **On** in the pop-up menu, and press the **Select** key.
- 3 Highlight the **Trig to X** field. Using the knob, move the X Marker to the lowest point on the negative pulse.

You may need to expand or compress the waveform, using the s/Div field to see a complete period of the waveform on the display.

- 4 Highlight the **Trig to O** field. Using the knob move the O Marker to the same point on the next negative edge after the X Marker.
- 5 Read the period of the clock in the **Tx to To** field.

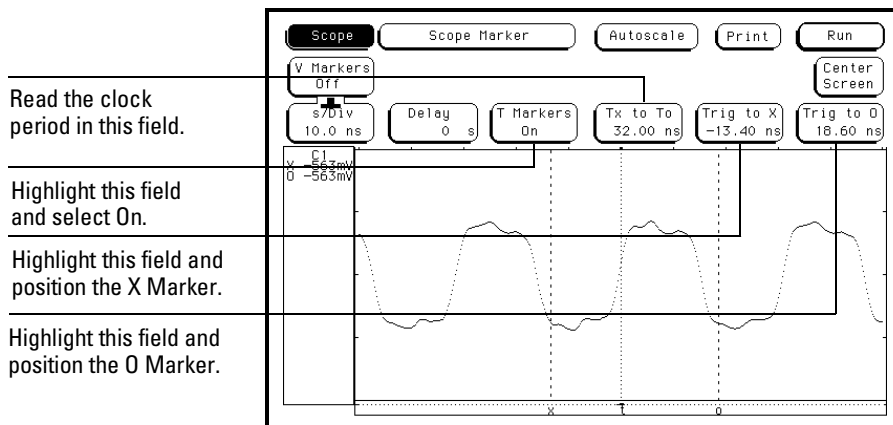

Measuring the Clock Period Manually with the X and O Markers

Measure the Clock Period with Auto Measure

The Auto Measure function allows you to automatically measure many signal parameters.

- 1 Press the **Meas** MENU key. **Meas** is printed in white on the MENU key.
- 2 Read the clock period in the box below the top row of fields.

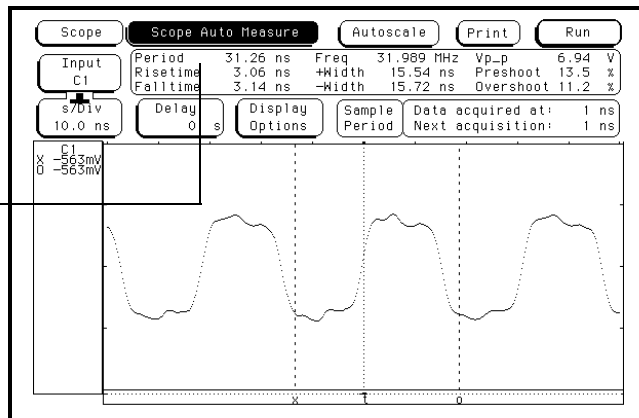

The clock period is displayed in this field.

Measuring the Clock Period with Auto Measure

Read Voltage with the Markers

You can use the time and voltage markers to make time and voltage measurements at specific points on the waveform.

- 1 Press the **Marker MENU** key.
- 2 Highlight the **V Markers Off** field, and press the **Select** key.
- 3 Highlight the **Va Volts** field. Rotate the knob and watch the Va marker scroll up and down the screen across the displayed waveform.
Notice the changing voltage value in the **Va Volts** field.

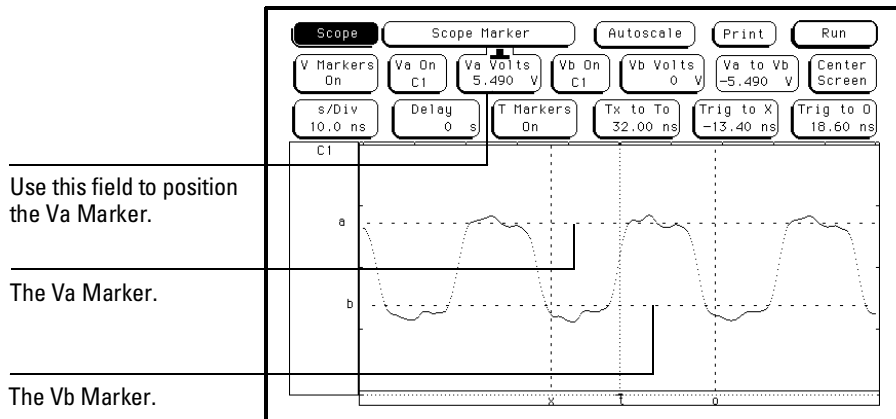

Reading the Voltage at the Markers

Triggering the Oscilloscope with the Timing Analyzer

Triggering the Oscilloscope with the Timing Analyzer

You can use the oscilloscope and the timing analyzers together so that the data and trigger points can be time-correlated. To perform these exercises, you need an analyzer with an oscilloscope.

These exercises show you how to make the timing analyzer trigger the oscilloscope inside the analyzer to find a glitch on the training board.

To do these exercises you need an HP 1660CS, HP 1661CS, HP 1662CS, or an HP 1663CS analyzer. The CS models have the built in oscilloscope.

In this chapter, you will:

- Set the jumpers
- Connect the oscilloscope probe
- Get the waveform on the display
- Change the oscilloscope trigger
- Turn on the timing analyzer
- Set up the timing format menu
- Define the timing trigger term
- Set up the timing trigger specification
- Arm the oscilloscope with the timing analyzer
- Add oscilloscope waveform to the timing waveforms
- Capture the glitch with the timing analyzer and oscilloscope
- Align the glitch displayed by the oscilloscope and analyzer

Before You Begin

1 Decide what to do next.

If you have just completed all of the exercises in Chapters 2 through 7, go to the "Set the Jumpers" exercise, on the next page.

If you have not just completed all of the exercises in Chapters 2 through 7, go to step 2.

2 Load the configuration files CH08._A, and CH08._B.

When loading these files, you must set the analyzer to load **All**, because you are loading two types of files for this exercise. Setting the analyzer to load **Analyzer** like you did in previous exercises, will only load CH07._A properly.

The files will default all system settings and then set up the analyzer and oscilloscope as if you had just completed all of the exercises in Chapters 2 through 7. If you need instructions to load the configuration files, refer to chapter 11, "To Load a Configuration File."

3 Connect Pod 1.

Connect Pod 1 of the analyzer to J1 on the Training Board. For the HP 1660s, Pod 1 is the top cable in the left-most position when you are facing the rear of the logic analyzer.

Set the Jumpers

You will create the glitch on bit 7 of the counter on the training board by setting the glitch jumper to ON.

- **Set the jumpers as shown below.**

For more information about setting the jumpers, refer to chapter 11, "To Set the Jumpers."

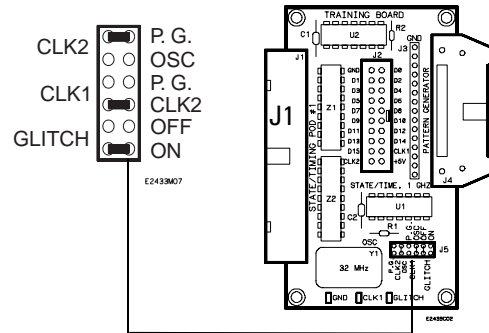

Setting the Jumpers

Result

The glitch on bit 7 is turned on.

Connect the Oscilloscope Probe

- 1 Connect the oscilloscope probe to channel 1 on the front panel.
- 2 Connect the probe tip to the test point labeled "Glitch" on the Logic Analyzer Training Board.

Note that this is a different test point than the "CLK 1" test point that was used in Chapter 7.

- 3 Connect the probe ground lead to the test point labeled "Ground" on the training board.

Note

Leave Pod 1 connected to J1. This provides +5 V for the training board.
If Pod 1 is not connected to J1, connect it now.

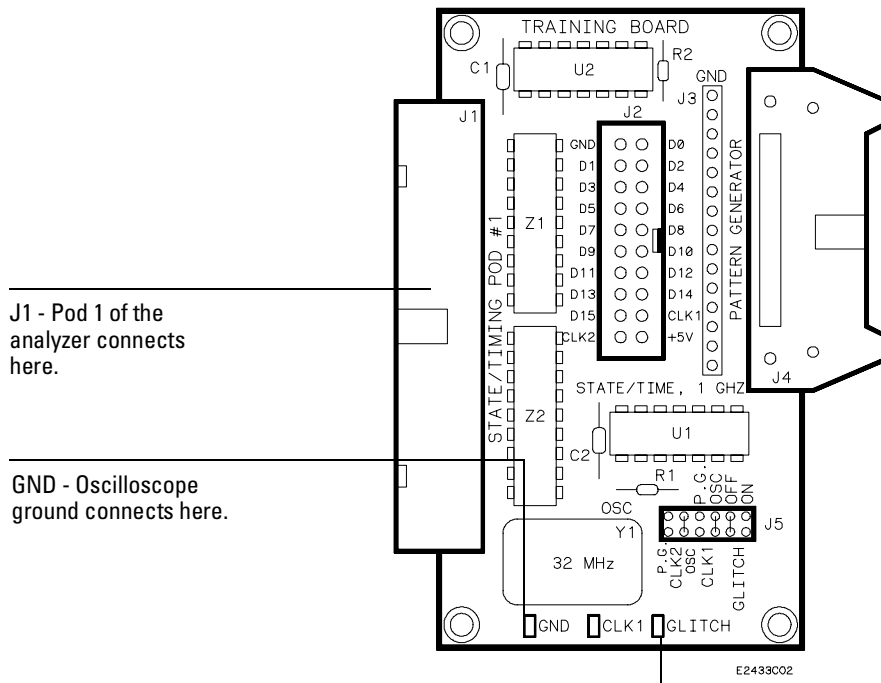

GLITCH - Oscilloscope probe tip connects here. **Connecting the Oscilloscope Probe**

Get the Waveform on the Display

The first step when using an oscilloscope is to get the waveform on the display. Autoscale is an algorithm that automatically optimizes the display of one or more waveforms. The oscilloscope triggers at an arbitrary point until you set up the trigger conditions.

- 1 Press the **Config** key.
- 2 Highlight the field in the top, left corner of the display, and press the **Select** key. Highlight **Scope** in the pop-up menu, and press the **Select** key.
- 3 Highlight the **Autoscale** field and press the **Select** key. Highlight **Continue** in the pop-up menu and press the **Select** key.

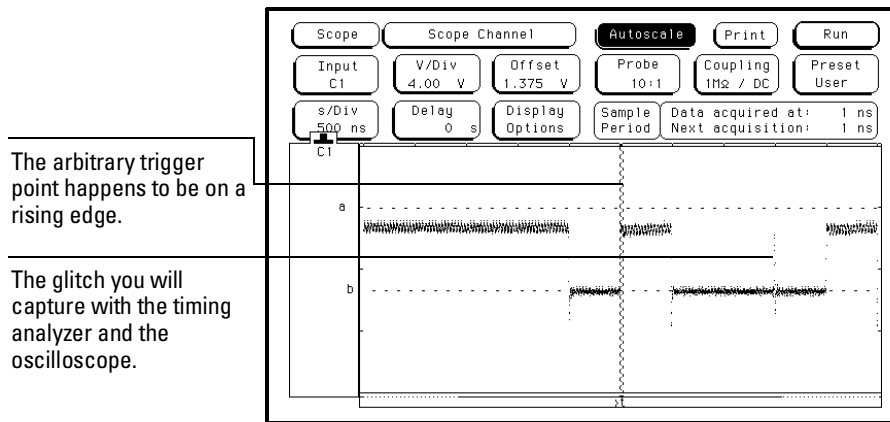

Running the Oscilloscope with Autoscale

Result

The waveform is on the display with the trigger occurring on a rising edge.

Change the Oscilloscope Trigger

You will be using the timing analyzer to find the glitch and then the oscilloscope to display it. This correlation of timing and scope is done by arming the scope with the timing analyzer. To capture the glitch on the scope, you want it to capture data immediately after the glitch is captured by the timing analyzer.

- 1 Press the **Trigger MENU** key.
- 2 Highlight the **Mode/Arm Edge** field at the left side of the display, and press the **Select** key.
- 3 Highlight **Immediate** in the pop-up menu, and press the **Select** key.

Setting this field to Immediate tells the oscilloscope to trigger immediately after the timing analyzer triggers.

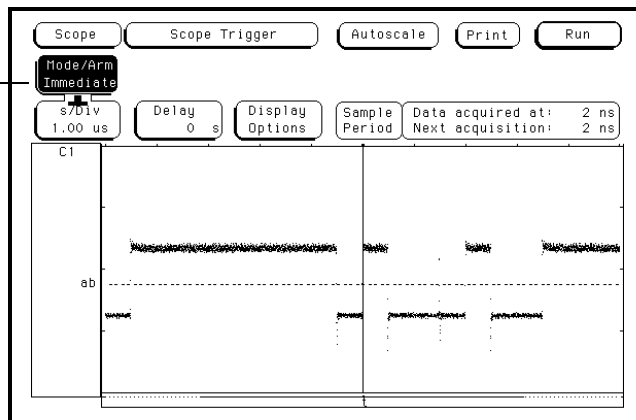

Changing the Oscilloscope Trigger

Result

The oscilloscope is set to capture data after the timing analyzer triggers on the glitch.

Turn On the Timing Analyzer

Now you will begin to set up the timing analyzer to capture the glitch.

- 1** Highlight the **Scope** field and press the **Select** key. Highlight **Analyzer** in the pop-up menu, and press the **Select** key.
- 2** Press the **Config** MENU key.

If the Configuration menu is already displayed when you press the **Config** key, then a pop-up menu will appear. Choose **Configuration** from the pop-up menu.

- 3** Highlight the field to the right of **Type** in the **Analyzer 1** box and press the **Select** key. Highlight **Timing** in the pop-up menu, and press the **Select** key.

Result

Analyzer 1 is set to timing mode.

Set Up the Timing Format Menu

Because you will be making a timing measurement, you will use the TCOUNT label that represents timing count. You will also set the timing acquisition mode to capture the glitch.

- 1 Press the **Format MENU** key.
- 2 Highlight the **SCOUNT** label, and press the **Select** key. Highlight **Turn Label Off** in the pop-up menu, and press the **Select** key.
- 3 Highlight the **TCOUNT** label, and press the **Select** key. Highlight **Turn Label On** in the pop-up menu, and press the **Select** key.
- 4 Highlight the **Timing Acquisition Mode**, and press the **Select** key. Highlight **Glitch, Half Channel, 125 MHz** in the pop-up menu, and press the **Select** key.

The Timing Acquisition Mode set to capture the glitch.

The TCOUNT label that represents timing count.

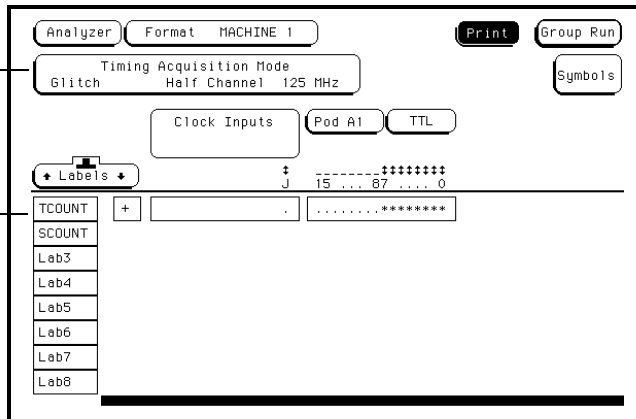

Setting Up the Timing Format Menu

Result

The label TCOUNT is turned on, and the timing analyzer acquisition mode is set to glitch.

Define the Timing Trigger Term "Edge 1"

The timing analyzer can be configured to trigger on edges, or a glitch. In this exercise, you will set the trigger term to glitch on bit 7.

- 1 Press the **Trigger MENU** key.
- 2 Highlight the **Modify Trigger** field, and press the **Select** key. Highlight **Clear Trigger**, press the **Select** key, then highlight **All**, and press the **Select** key.
- 3 Highlight the base field below **TCOUNT**, and press the **Select** key. Highlight **Binary** in the pop-up menu, and press the **Select** key.
- 4 Highlight the field to the right of **Edge 1**, and press the **Select** key.
- 5 Using the arrow key, move the cursor to highlight the asterisk in the pop-up menu for bit 7. Press the **Done** key.

The asterisk tells the analyzer to look for a glitch on bit 7 of the counter.

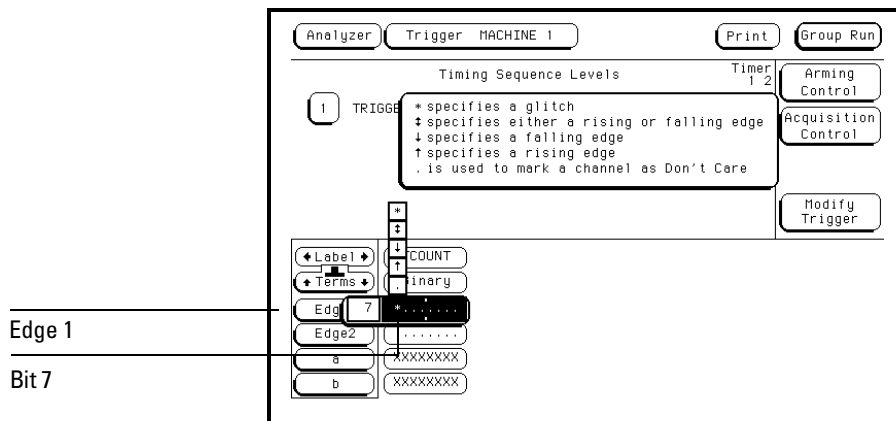

Defining Timing Trigger Terms Edge 1

Result

The term "Edge 1" is defined as a glitch on bit 7.

Set Up the Timing Trigger Specification

You will now tell the analyzer to trigger on the glitch the first time it occurs.

- 1 Highlight the **1** field in the **Timing Sequence Levels** box, and press the **Select** key.
- 2 Highlight the **>** field, and press the **Select** key. Highlight **Occurs** in the pop-up menu, and press the **Select** key.
- 3 Highlight the field next to **Trigger on**, and press the **Select** key. Highlight **Edge 1** in the pop-up menu, and press the **Select** key.
- 4 Highlight the field next to **Else on**, and press the **Select** key. Highlight **no state** in the pop-up menu, and press the **Select** key.
- 5 Press the **Done** key to close the **Sequence Level 1** pop-up menu.

The trigger term "Edge1" is set for the analyzer to look for the glitch on bit 7.

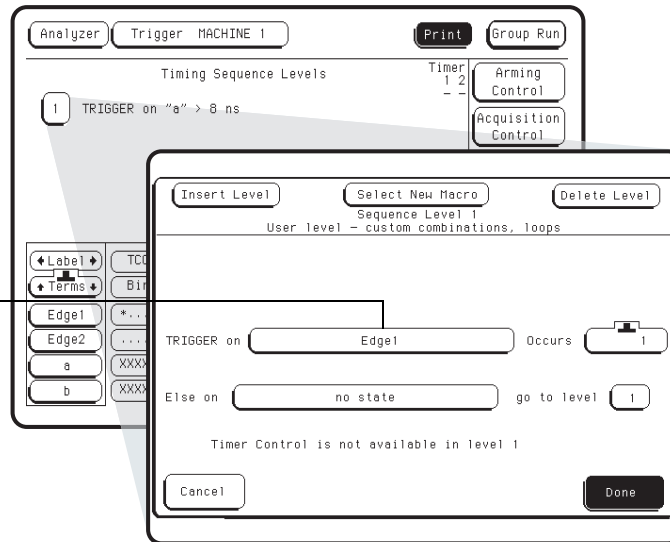

Setting Up the Trigger Specification

Result

Your trigger specification now shows: Level 1 - TRIGGER on "Edge1" 1 time.

Arm the Oscilloscope with the Timing Analyzer

The timing analyzer and the oscilloscope can be configured so that the timing analyzer's glitch triggering capability will capture the glitch, and then arm the oscilloscope so that it, too, captures the glitch.

- 1 Highlight the **Arming Control** field at the far right side of the screen, and press the **Select** key.
- 2 Highlight the field under **Scope Arm In**, and press the **Select** key. Highlight **Analyzer** in the pop-up menu, and press the **Select** key.

When you select the analyzer to arm the scope, the field under **Analyzer Arm In** changes to **Group Run**.

- 3 Press the **Done** key to exit the Arming Control pop-up menu.

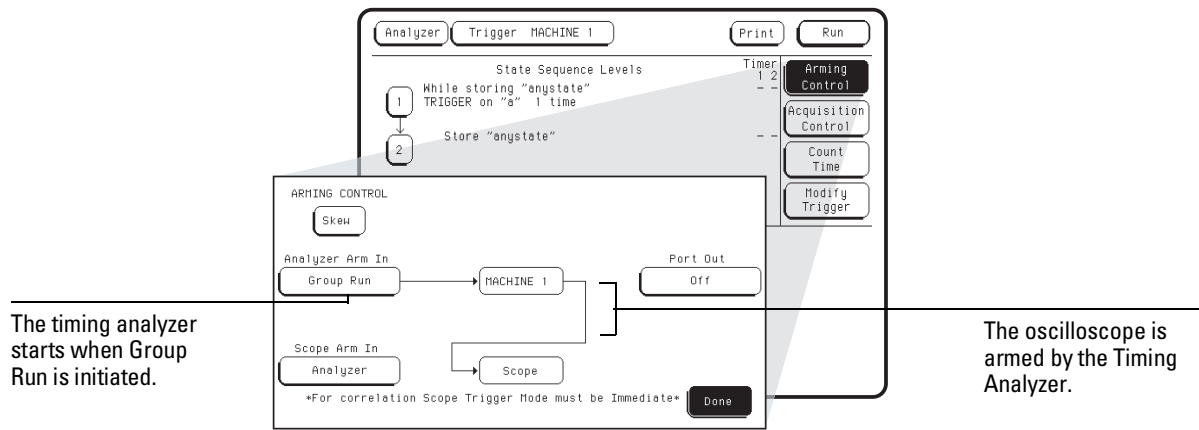

Arming the Oscilloscope with the Timing Analyzer

Result

The timing analyzer will look for the glitch, trigger, and then arm the scope, which allows the scope to capture the glitch.

Add Oscilloscope Waveform to the Timing Waveforms

To see the correlation between the timing analyzer and the oscilloscope, you must insert the scope display into the timing waveform display.

- 1 Press the **Wform** MENU key to display the Waveform Machine1 menu.
- 2 Highlight the large field at the left side of the display. The **TCOUNT** label should be displayed in the large field.
If the **TCOUNT** label is not in the large field, then you need to add it. To add the **TCOUNT** label, highlight the large field, then press the **Select** key twice. Choose **Insert, Analyzer, TCOUNT**, then **Sequential** in the pop-up menus.
- 3 Using the knob, place the cursor on the **TCOUNT 7** label.
- 4 Press the **Select** key.
- 5 Choose **Insert, Scope**, then **C1** (oscilloscope channel 1) in the pop-up menus.

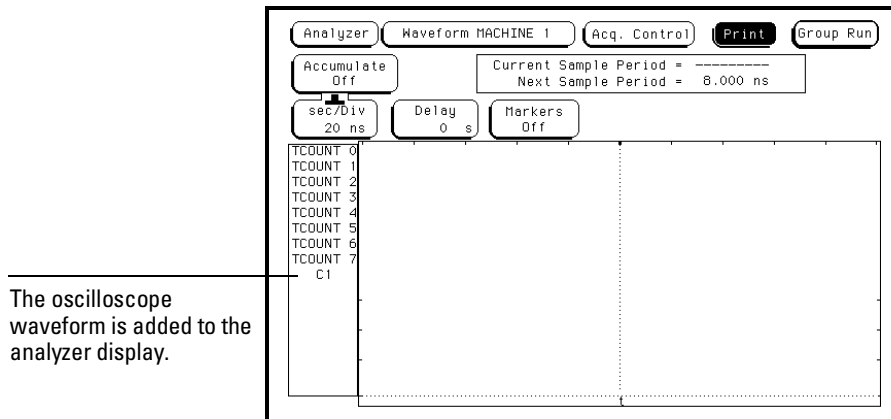

Adding Oscilloscope Waveform to the Timing Waveforms

Result

Both the timing waveform for **TCOUNT** and the oscilloscope waveform will be displayed when you run the analyzer.

Capture the Glitch with the Timing Analyzer and Oscilloscope

The timing analyzer runs, triggers, and then arms the oscilloscope. Notice the slight delay between the glitch displayed by the timing analyzer and the oscilloscope. This is caused by the intermodule bus when one instrument arms another. In the following exercise, you will align the glitch in the two displays.

- 1 Highlight the **Group Run** field, and press the **Select** key. Highlight **Single** in the pop-up menu, and press the **Select** key.
- 2 Highlight the **s/Div** field, then rotate the knob to change the s/Div to 20 ns.

You will now see the glitch on both the oscilloscope waveform, and on TCOUNT 7 in the timing analyzer section of the display.

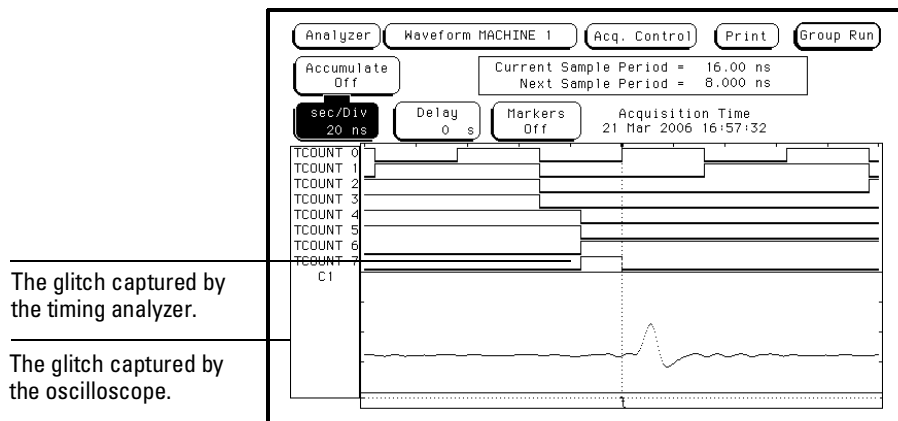

The glitch captured by the timing analyzer.

The glitch captured by the oscilloscope.

Capturing the Glitch on the Oscilloscope

Result

The glitch is captured and displayed by the analyzer and oscilloscope.

Align the Glitch Displayed by the Oscilloscope and Analyzer

You can align the glitch displayed by the analyzer and scope by measuring the distance between the falling edge on the timing display with the falling edge of the scope display. Then you use the skew feature to move the timing waveform over so that the two displays are aligned.

- 1 Highlight the **Markers Off** field, and press the **Select** key. Highlight **Time** in the pop-up menu, and press the **Select** key.
- 2 Highlight the **Trig to 0** field, and use the knob to place the O marker on the falling edge of the glitch shown by the scope.
- 3 Take note of the time delay in ns between the trigger point and the O marker. This is the time delay you will use to realign the two displays.

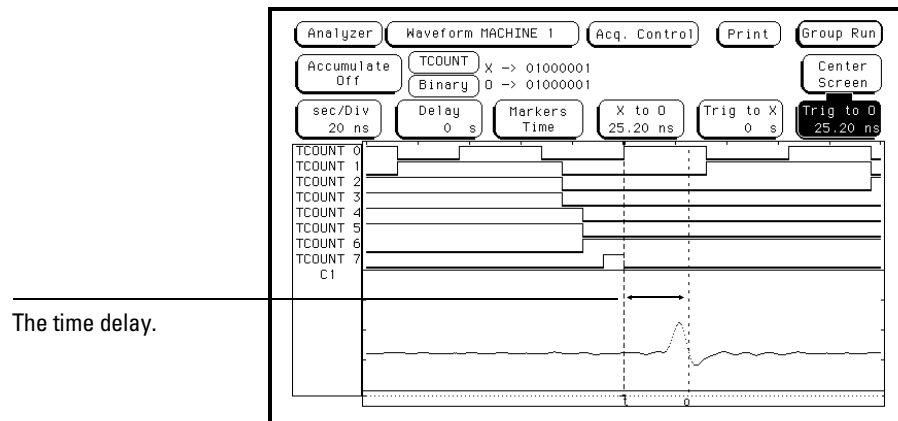

Measuring the Time Delay

Triggering the Oscilloscope with the Timing Analyzer
Align the Glitch Displayed by the Oscilloscope and Analyzer

- 4 Press the **Trigger MENU** key.
- 5 Highlight the **Arming Control** field and press the **Select** key.
- 6 With the **Skew** field highlighted, press the **Select** key.
- 7 With the **Analyzer** field highlighted, press the **Select** key.
- 8 Use the knob to change the units to ns, and type in the time delay you measured with the **Trig to 0** marker.
- 9 Press the **Done** key until you return to the Trigger Menu.
- 10 Highlight the **Group Run** field, and press the **Select** key. Highlight **Single** in the pop-up menu, and press the **Select** key.

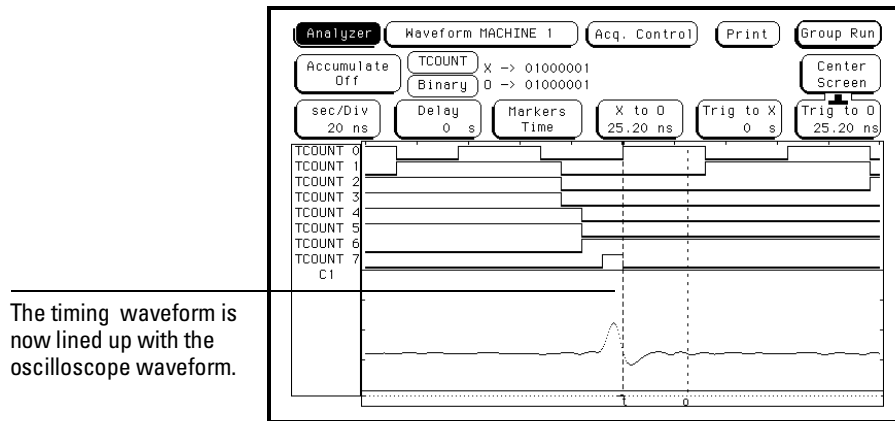

Aligning the Glitch Displayed by the Oscilloscope and Analyzer

Result

The analyzer display is time-aligned with the scope display.

Using the Pattern Generator

Using the Pattern Generator

The pattern generator provides programmable digital output that can be used to stimulate and control a system under test. These exercises will show you how to program the pattern generator so that it provides a pattern of "walking ones." Because the pattern generator is an output module, the timing analyzer will be used to view the pattern generator's output.

These exercises also show you a simple process that represents basic stimulus/response testing. For example, if you are applying the "walking ones" pattern from the pattern generator to a memory, you can use the timing analyzer to see if the "walking ones" pattern is being written to and read from memory properly.

In this chapter, you will:

- Connect the pattern generator
- Turn on the timing analyzer
- Change a label name
- Modify channel assignments
- Set up the timing analyzer trigger
- Add a pattern generator label to the timing waveform display
- Set up the pattern generator format menu
- Program the pattern generator output
- Add program lines
- Start the pattern generator and view the walking ones pattern
- Stop the pattern generator

Before You Begin

1 Load the configuration file for chapter 3, CH03_60._A.

If you need instructions to load the configuration files, refer to chapter 11, "To Load a Configuration File."

2 Connect Pod 1.

Connect Pod 1 of the analyzer to J1 on the Training Board. For the HP 1660s, Pod 1 is the top cable in the left-most position when you are facing the rear of the logic analyzer.

3 Set the jumpers as shown below

The jumper setting of J5 on the training board for this chapter are the same as the default settings. For more information about setting the jumpers, refer to chapter 11, "To Set the Jumpers."

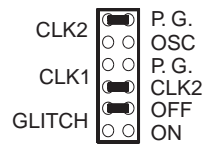

E2439M06

Connect the Pattern Generator

- Connect the pattern generator output Pod 4 to the TTL Data Pod. Then connect the TTL Data Pod to J4 (labeled PATTERN GENERATOR) on the training board.

For more information about setting the jumpers, refer to chapter 11, "To Set the Jumpers."

Note

Pod 1 of State/Timing is not only used to acquire the pattern generator's output pattern, it also provides the needed + 5V for the training board.

Pod 4 of the pattern generator.

J4 - The TTL Data Pod, with Pod 4 of the pattern generator attached, connects to the training board here.

J1 - Pod 1 of the analyzer connects here.

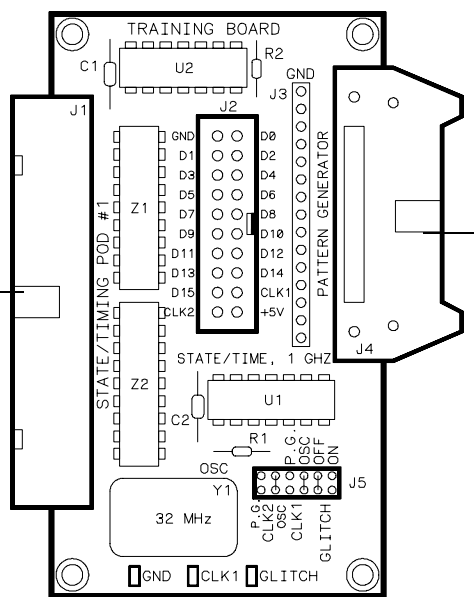

E2433C02

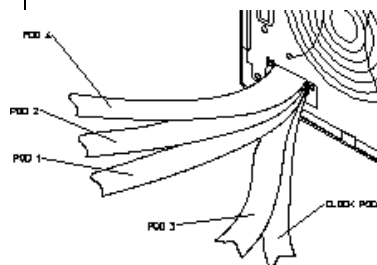

Connecting the Pattern Generator

Turn On the Timing Analyzer

1 Press the **Config** MENU key.

If the Configuration menu is already displayed when you press the **Config** key, then a pop-up menu will appear. Choose **Configuration** from the pop-up menu.

2 Highlight the field to the right of Type in the Analyzer 1 box and press the **Select** key. Highlight **Timing** in the pop-up menu, and press the **Select** key.

Result

Analyzer 1 is set to timing mode.

Change a Label Name

In this exercise, you will change a label name to PATGEN to represent the pattern generator data captured by the timing analyzer.

- 1 Press the **Format MENU** key.
- 2 Highlight the label **Lab2** and type PATGEN. Press the **Done** key.
- 3 Highlight the field labeled TCOUNT, and press the **Select** key. Highlight **Turn Label Off**, and press the **Select** key.

Note

Turning the labels off rather than modifying them saves them for later use.

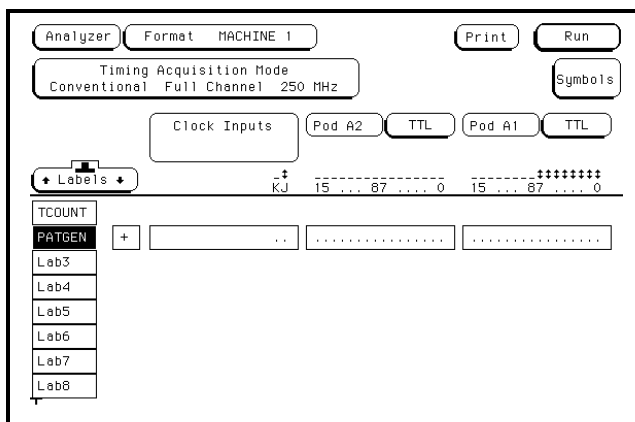

Changing a Label Name

Result

Lab2 is now changed to PATGEN, and the label TCOUNT is turned off.

Modify Channel Assignments

In this exercise you will assign channels 8 through 11 to Pod A1, which is attached to J1 of the training board. The analyzer will then use these channels to capture the output of the pattern generator.

- 1 Highlight the field showing the 16 channels of Pod A1 to the far right of the PATGEN label. Press the **Select** key.
- 2 Using the knob, move the cursor to channel 11 in the pop-up menu. Then, press the \uparrow (up-arrow) key to put asterisks in channels positions 11 through 8.
- 3 Press the **Done** key.

The asterisks (*) assign bits 8 through 11 of Pod A1 to the label PATGEN.

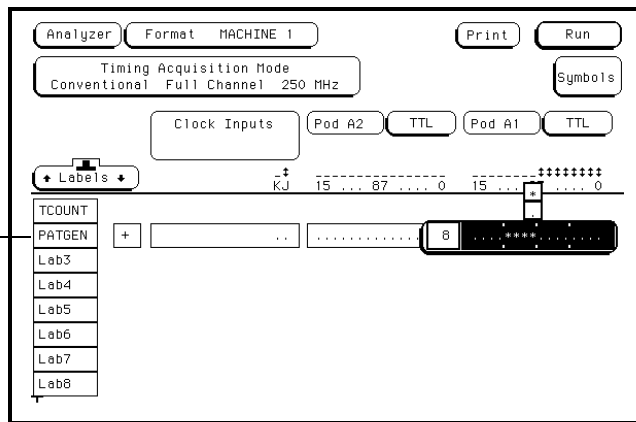

Modifying the Channel Assignments

Result

Channels 11 through 8 of Pod A1 are assigned to the label PATGEN.

Set Up the Timing Analyzer Trigger Term

The trigger term 'a' is set to 1 so that the analyzer will trigger on the "walking ones" provided by the pattern generator.

- 1 Press the **Trigger MENU** key.
- 2 Highlight the field to the right of term "a", and type a 1 into the field.
- 3 Press the **Done** key.
- 4 Highlight the **1** field in the Timing Sequence Levels box, and press the **Select** key.
- 5 Highlight the field to the right of >, and turn the knob to select 8 ns for the pattern duration. Press the **Done** key.

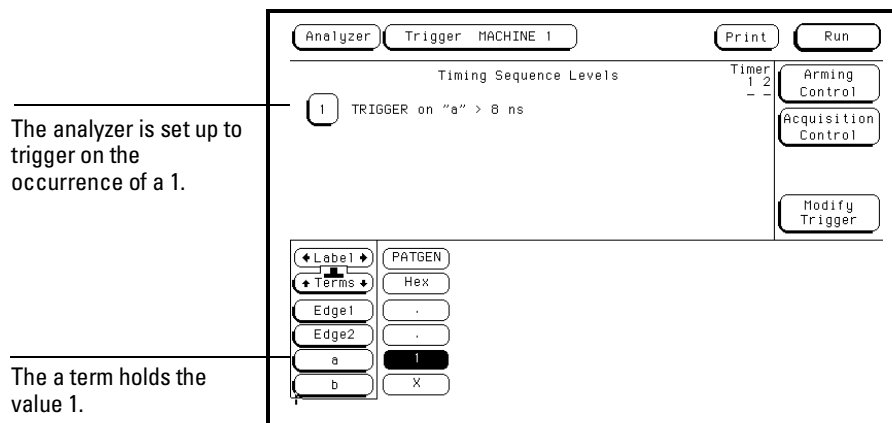

Setting Up the Timing Analyzer Trigger Term

Result

The logic analyzer is set up to trigger on the occurrence of a 1.

Add a Pattern Generator Label to the Timing Waveform Display

The new label PATGEN must be added to the Waveform display for the captured data to be displayed.

- 1 Press the **Waveform** menu key.
- 2 Highlight the field under Labels on the left side of the screen, and press the **Select** key twice.
- 3 Press the **Select** key to select **Insert**.
- 4 Press the **Select** key to select PATGEN.
- 5 Choose **Sequential** from the pop-up menu.

The PATGEN label is placed in the Waveform display.

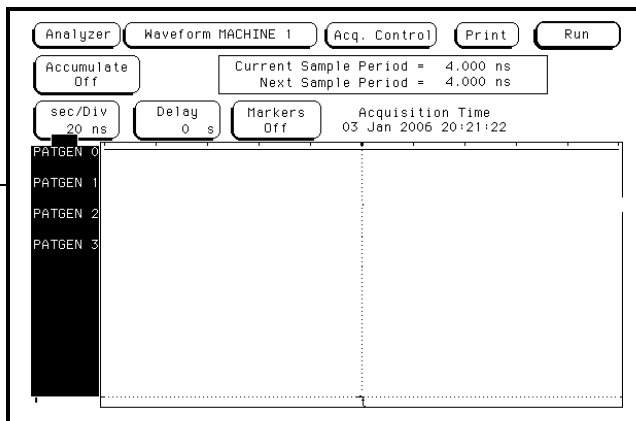

Adding a Pattern Generator Label to the Timing Waveform Display

Result

The Waveform display is set up to display the four bits of the label PATGEN.

Set Up the Pattern Generator Format Menu

For the pattern generator to output the "walking ones" to the logic analyzer, the lower four bits of Pod 4, which is connected to the training board through the TTL Data Pod, must be assigned to PATGEN.

- 1 Highlight the **Analyzer** field in the top-left corner of the screen, and press the **Select** key. Highlight **Patt Gen**, and press the **Select** key.
- 2 If the Format Menu of the Pattern Generator is now displayed, go to step 4.
- 3 Press the **Format MENU** key.
- 4 Highlight **Lab1** below Label, and press the **Select** key. Highlight **Modify Label** in the pop-up menu, and press the **Select** key.
- 5 Type PATGEN, and Press the **Done** key.
- 6 Highlight the field showing the Pod B4 to the right of PATGEN, and press the **Select** key.

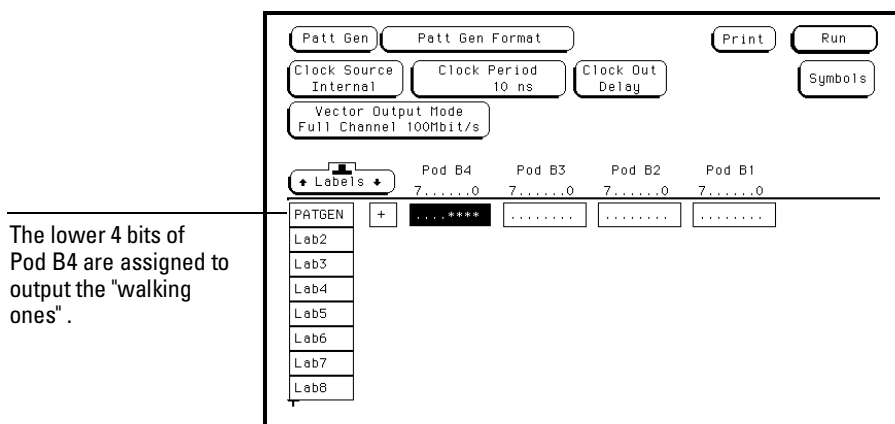

Setting Up the Pattern Generator Format Menu

- 7 Using the knob, move the cursor to channel 3 in the pop-up menu. Then, press the \uparrow (up-arrow) key to put asterisks in channels positions 0 through 3.
- 8 Press the **Done** key.
- 8 Highlight the field showing the Pod B3 to the left of the field you just modified, and press the **Select** key.
- 9 Press the **Clear Entry** key. Press the **Done** key.
- 10 Highlight the field showing the Pod B1, and press the **Select** key.
- 11 Press the **Clear Entry** key. Press the **Done** key.

Result

The lower four bits of Pod 4 is assigned to the label PATGEN.

Program the Pattern Generator Output

The Sequence window is used to program the pattern generator output. In this exercise, you will change the base field to binary and program the first "walking one."

- 1 Highlight the **Pat Gen Format** field, and press the **Select** key.
- 2 Highlight **Pat Gen Sequence** field in the pop-up menu, and press the **Select** key.
- 3 Highlight the base field below the PATGEN field, and press the **Select** key. Highlight **Binary** in the pop-up menu, and press the **Select** key.
- 4 Use the knob to scroll to the field under *****MAIN SEQUENCE START*****.
- 5 Use the arrow keys to highlight the far-right field.
- 6 Press the **Select** key. Type 0001 and press the **Done** key.

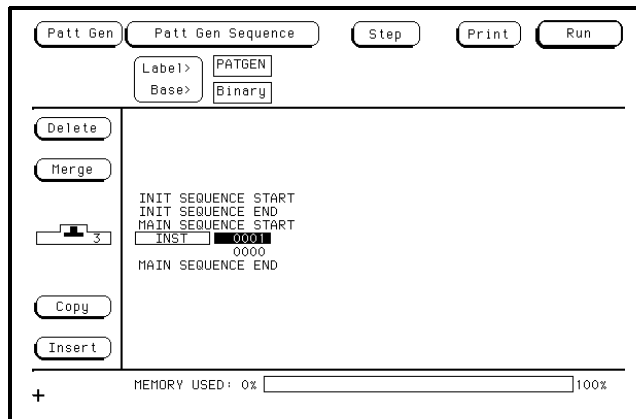

Programming the Pattern Generator Output

Result

The base field is in binary with the first "walking one" of 0001 programmed.

Add Program Lines

You will need four lines for the "walking ones" program. In this exercise, you will insert two lines after 0001 and complete the walking ones program.

- 1 Highlight the **Insert** field, and press the **Select** key two times to add two additional program lines to the listing.
- 2 Using the knob, scroll to the next program line for the next "walking one."
- 3 Highlight the far-right, and press the **Select** key.
- 4 Type 0010 in the field, and press the **Done** key.
- 5 Repeat steps 2 through 4 for program lines 2 and 3 entering 0100, then 1000, respectively.

The "walking ones" program.

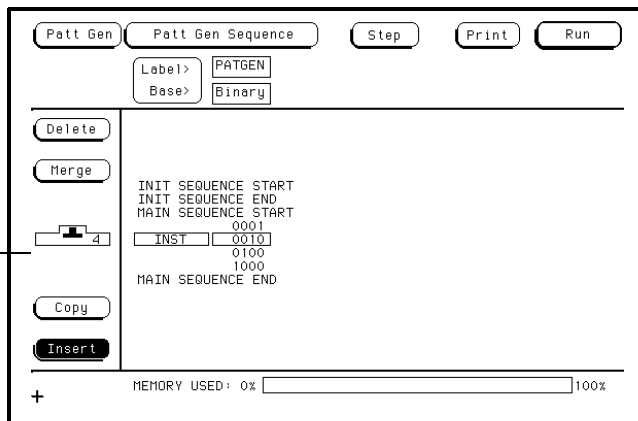

Adding Program Lines

Result

The "walking ones" program is complete. The pattern generator will output 0001, 0010, 0100, 1000 to the logic analyzer.

Start the Pattern Generator and View the Walking Ones Pattern

When you select **Run** and **Repetitive**, the Pattern Generator begins to run in repetitive mode. The output is the repeating "walking ones" pattern. You will not see this output until you switch to the timing analyzer waveform display.

The pattern generator will run independently until you stop it by pressing the **Stop** key.

- 1 On the front panel of the logic analyzer, press the blue SHIFT key, and then push the **Run** key to run the pattern generator repetitively.
- 2 Highlight the **Patt Gen** in the top-left corner of the screen, and press the **Select** key. Choose **Analyzer** from the pop-up menu.
- 3 Highlight the the **Run** field, and press the **Select** key. Choose **Single**, and press the **Select** key.

The Timing analyzer runs a single trace and automatically displays the Waveform 1 menu in which you see the "walking ones" patter.

- 4 Highlight the **s/Div** field.
- 5 Turn the knob until the **s/Div** field displays 20 ns.

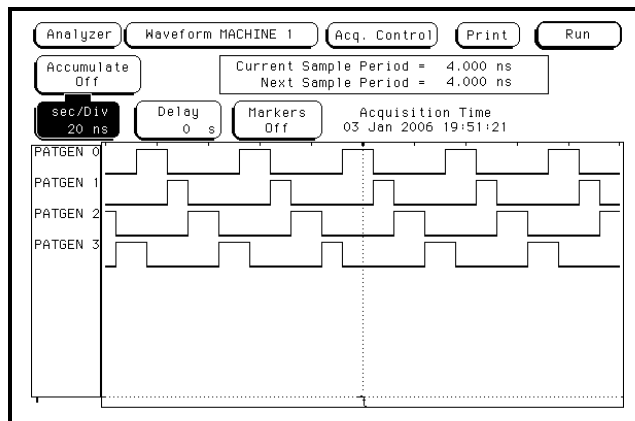

Starting the Pattern Generator and Viewing the Walking Ones Pattern

Stop the Pattern Generator

- 1 Highlight the **Analyzer** field, and press the **Select** key. Highlight **Patt Gen** in the pop-up menu, and press the **Select** key.
- 2 Highlight the **Stop** field, and press the **Select** key.

The pattern generator requires CPU time when it is running independently in the repetitive mode. Stopping the pattern generator now will prevent other exercises that do not use it from running slower than normal.

Introduction to Inverse Assembly

Introduction to Inverse Assembly

An inverse assembler translates the captured data into microprocessor instructions.

To perform inverse assembly, you must probe a microprocessor and load the correct configuration and inverse assembler. The training board does not have a microprocessor. Therefore, for these exercises you will load a sample listing to simulate the captured microprocessor instructions.

In this chapter you will:

- Load the inverse assembler and sample listing
- View the address, data, and status labels
- View the assembly listing
- Filter the captured data

Load the Inverse Assembler and Sample Listing

In this exercise you will load a configuration file and the inverse assembler to translate the binary data. You will not be making the measurement because the training board does not have a microprocessor.

- 1** Place the flexible disk labeled "Logic Analyzer Training Kit Configurations" in the disk drive.
- 2** Press the **Config** MENU key.
- 3** Highlight the field to the right of **Type** in the Analyzer 1 box. Press the **Select** key and choose **State** in the pop-up menu.
- 4** Press the **System** MENU key.
- 5** Highlight the field to the right of **System**, press the **Select** key, and choose **Flexible Disk** in the pop-up menu.
- 6** If you are using an HP 1660 series analyzer, load the **Analyzer** with these files:
 - IA386E (inverse assembler)
 - TRC_386._A. (sample listing)
- 7** If you are using an HP 1670 series analyzer, load the **Analyzer** with these files:
 - ICPU32 (inverse assembler)
 - TRC_32._A (sample listing)

Result

Both the inverse assembler and the listing are loaded onto the analyzer with the necessary configurations.

See Also

"To Load a Configuration File" in chapter 11 for more information.

View the Address, Data, and Status Labels

The labels, pods and bit assignments were configured when you loaded the sample listing. Often, you will load a configuration file you built or one supplied with the preprocessor.

There are three labels the inverse assembler needs to translate the binary data correctly: ADDR (address bus), DATA (data bus), and STAT (status). These labels must be capitalized to be recognized by the inverse assembler.

- 1 Press the **Format MENU** key.
- 2 Notice the required ADDR, DATA, and STAT labels.

The ADDR label collects the activity on the address bus. The DATA label collects the data and is what the inverse assembler translates into instructions. The STAT label records the type of instruction or bus transaction.

- 3 Highlight the **Pods** field and turn the knob counter clockwise to scroll through the pods.

Notice that the bits are already assigned to the pods of each label. If you are using a 1670 series analyzer, your label and bit assignments will be different than those in the graphic below. This is because you are using a different sample listing and assembler.

The Pods field is used to scroll through the pods to see the bit assignments.

The Labels field is used to scroll through the labels.

ADDR, DATA, and STAT are used by the inverse assembler.

Analyzer
Format 80386
Print
Run

State Acquisition Mode
Full Channel/4K Memory/100MHz
Master Clock
K1
Symbols

Clock Inputs
Pod A6 TTL
Pod A5 TTL

Pods
Master Clock
Master Clock

Labels
PNMLKJ
15 ... 87 ... 0
15 ... 87 ... 0

ADDR	+
DATA	+
STAT	+*****
H/R	+*
D/C	+*
H/IO	+*..
BE	-****
SIZE	+*

Viewing the Address, Data, and Status Labels

View the Assembly Listing

You can view the captured data in the mnemonic form just as you can view data in the Hex, Decimal, or Binary forms.

1 Press the **List MENU** key.

If you are using a 1670 series analyzer, your listing will be different than the one in the graphic below. This is because you are using a different sample listing and inverse assembler.

Analyzer Listing 80386 Invasm Options Print Run				
Markers Off				
Label>	ADDR	80386DX Inverse Assembly		STAT
Base>	Hex	A[3:0]	Mnemonic	Symbol
0	000FEF60	0	JMP 000FEF62H	OPCODE F
		2	-IN AL,#61H	
1	000FEF64	4	-TEST AL,#10H	OPCODE F
		6	-JZ 000FEF60H	
2	000FEF68	8	-DEC CX	OPCODE F
		9	-JZ 000FEF7BH	
		B	-IN AL,DX	
3	000FEF6C	C	-TEST AH,AL	OPCODE F
		E	-JZ 000FEF7CH	
4	000FEF70	0	-JMP 000FEF72H	OPCODE F
		2	-IN AL,#61H	
5	00000061		xxxx20xxH read i/o	I/O READ
6	000FEF60	0	-JMP 000FEF62H	OPCODE F
		2	IN AL,#61H	
7	000FEF64	4	TEST AL,#10H	OPCODE F
		6	JZ 000FEF60H	

Viewing the Assembly Listing

2 Highlight the line number field on the left side of the display and use the knob to scroll down through the listing.

If the inverse assembler gets out of sync with the captured data the code will not be translated correctly. To realign the assembler and the data using an HP 1660 series analyzer, place one of the OPCODE F lines at the top of the screen. Then highlight the **Invasm Options** field, press the **Select** key, and choose **Align** from the Inverse Assembly Options pop-up. If you are using an HP 1670 series analyzer, highlight the **Invasm** field, and press the **Select** key.

Filter the Captured Data

Note

This exercise can only be done with the HP 1660C, HP 1660CS, HP 1661C, or the HP 1661CS analyzer.

If the program you are running is large or you are not interested in looking at all of the code, you can suppress the types of instructions you are not interested in. In this exercise you will look at the general flow of the code by showing only the jumps and suppressing all other types of instructions.

- 1 Highlight the **Invasm Options** field and press the **Select** key.
- 2 Suppress all of the instruction types, except "Jumps:", by highlighting each field and pressing the **Select** key.
- 3 Press the **Done** key to close the Inverse Assembly Options pop-up.
- 4 Use the knob to scroll through the listing of jumps.

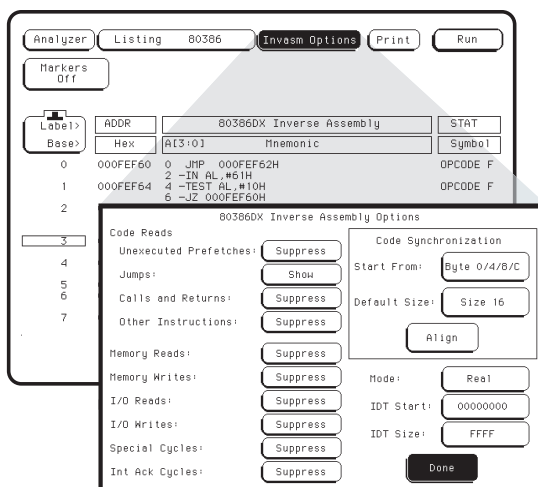

Filtering the Captured Data

Result

The captured data can be filtered in various ways. In this exercise, the inverse assembly code is filtered so that only the jump instructions are displayed.

Setting the Jumpers and Loading the Configurations

Setting the Jumpers

The jumpers on J5 of the training board are used to control the source of the state clock and to turn the glitch on or off. Before you start each chapter, you should check the jumpers to make sure they are properly set. The "To Set the Jumpers" exercise, on the next page, gives you the information you need to change the jumpers. Table 1 shows you the jumper settings for the chapters .

Table 1

Jumper Settings

		Jumper	
	Glitch	CLK1	CLK2
Chapter 4 (change during exercises)	ON	OSC	P.G. (Pattern generator)
Chapter 8	ON	OSC	P.G.
All Other Chapters (Default)	OFF	OSC	P.G.

To Set the Jumpers

- 1 Pull the appropriate jumper off of the pins of J5.
- 2 Push the jumper onto the correct pins of J5. You only need to change jumpers that differ from the settings in table 1.

Set the jumpers at their default settings for all chapters. Table 1 shows you the default settings and the settings for each chapter. Chapter 4, "Comparing State Traces," and chapter 8, "Triggering the Oscilloscope with the Timing Analyzer," requires you to change the setting of the glitch jumper.

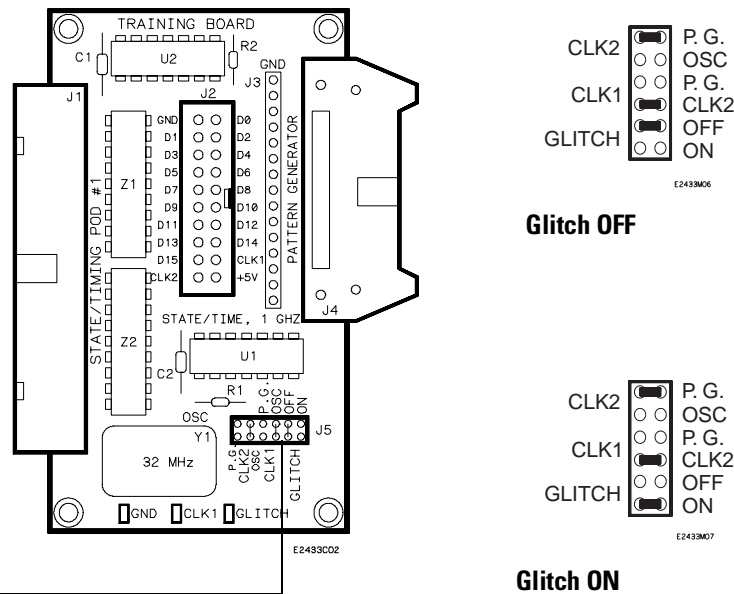

J5 - Jumpers are set here.

Setting the Jumpers

Loading the Configurations

If you are not performing the exercises in order, you may need to load configuration files to set up your system so that you can complete the exercises. The "To Load a Configuration File" exercise on the next two pages gives you the information you need to load configuration files. The flexible disk labeled "Logic Analyzer Training Kit Configurations," which you received in this training kit, contains the configuration files. The files are listed in Table 2, below.

If you are doing the exercises for the first time, we recommend you follow the steps in each consecutive exercise, from chapter 1 through chapter 5, without loading the configuration files. If you do not want to do the exercises in order, you can load the files listed in the "Before You Begin" section of a chapter, then do the exercises in that chapter.

Table 2

Configuration Files

Filename	File description
CH03_60._A	State Exercises
CH03_70._A	State Exercises
CH04._A	Compare Exercises
CH05._A	Mixed Mode Exercises
CH06._A	Advanced State Exercises
CH07._A and CH07._B	Oscilloscope Exercises
CH08._A and CH08._B	Oscilloscope/Timing Exercises
CH03_60._A	Pattern Generator Exercises
TRC_386._A and IA386E	Inverse Assembly for the HP 1660s
TRC_32._A and ICPU32	Inverse Assembly for the HP 1670s

To Load a Configuration File

There are two configuration files you will be loading. One for the analyzer CH0X._A, and one for the oscilloscope CH0X._B. For exercises that only use the analyzer, you will only load the CH0X._A file. For exercises using the scope, you will load both the CH0X._A and the CH0X._B files.

- 1** Place the flexible disk labeled "Logic Analyzer Training Kit Configurations" in the disk drive.
- 2** Press the **System** MENU key.
- 3** Highlight the field to the right of **System**, then press the **Select** key. Choose **Flexible Disk** in the pop-up menu, and press the **Done** key. The Disk Menu is now displayed.

If the file directory has not been previously read by the logic analyzer, you will see "reading directory . . ." before the directory listing is displayed.

- 4** Highlight the field below the **System** field, on the left side of the screen, then press the **Select** key. Highlight **Load** in the pop-up menu, then press the **Done** key.

See the figure on the next page if you need help.

- 5** Highlight the field to the right of **Load**, then press the **Select** key. Highlight **Analyzer** in the pop-up menu, then press the **Done** key.

The procedure for loading a configuration file continues on the next page.

- 6** Using the knob, place the file name you want to load on the light gray center line of the display.

Setting the Jumpers and Loading the Configurations To Load a Configuration File

7 Highlight the **Execute** field, then press the **Select** key.

Note

If you are using a logic analyzer model other than an HP 1661, a message may appear, telling you that some pod information has been changed or truncated, or needs to be connected in a particular way. This is not an error. The message appears because your logic analyzer has a different number of data pods than an HP 1661, which was used to create the file you are loading.

8 Repeat steps 6 and 7 for any other files you want to load. When you are finished loading files, highlight the **System** field, then press the **Select** key. Choose **Analyzer** in the pop-up menu.

Setting this field to Load tells the analyzer to load the file selected.

The knob places the name of the file you want to load on this line.

Setting this field to Analyzer tells the system to load the state and timing analyzers.

Selecting this field loads the file.

DOS Filename	Date	Time	Bytes	File Description
CH03_60	..A	10Feb06	12:54:16	75776 STATE EXERCISES
CH03_70	..A	10Feb06	12:54:16	75776 STATE EXERCISES
CH04	..A	10Feb06	13:07:44	75776 COMPARE EXERCISES
CH05	..A	10Feb06	13:46:56	75776 MIXED MODE EXERCISES
CH06	..A	10Feb06	13:55:24	75776 ADVANCED STATE EXERCISES
CH07	..A	10Feb06	14:06:56	75776 OSCILLOSCOPE EXERCISES
CH07	..B	10Feb06	14:07:04	69376 OSCILLOSCOPE EXERCISES
CH08	..A	10Feb06	15:05:28	75776 OSCILLOSCOPE/TIMING EXERCISES
CH08	..B	10Feb06	15:05:36	69376 OSCILLOSCOPE/TIMING EXERCISES

PWD: \
DOS Disk Space(bytes) - Total: 1,474,560 Free: 651,264

Loading a Configuration File

All About the Logic Analyzer Training Board

All About the Logic Analyzer Training Board

The training board helps you learn the basics of HP Logic Analyzers. The following reference information is provided for those who want to know more about how the training board works.

Power Source

The training board is powered by the +5 V supplied by the logic analyzer pods, so a logic analyzer pod must be connected to either J1 or J2 of the training board in order for the training board to work. If only J2 is connected, it must be connected to the logic analyzer through a termination adapter (HP part number 01650-63203).

CAUTION

If the termination adapter part number is HP 01650-63201, the CLK2 jumper must be set to P.G. to avoid connecting the output of the oscillator to +5 V and eventually damaging the oscillator.

If J1 is connected, the termination adapter is not required because J1 is terminated on the board by Z1 and Z2.

Circuit Description

The training board uses an 8-bit ripple counter running at 32 MHz to produce transitions on the lower 8 bits of a logic analyzer pod. The upper eight bits can be connected to the pattern generator through connector J4.

For state analysis, you can clock the state analyzer via the oscillator on the training board (reference designator Y1) or via a pattern generator in an HP 16500 system. The sources for clocks 1 and 2 are selected by the positions of jumpers CLK1 and CLK2, respectively. When the CLK1 and CLK2 jumpers are set to OSC (oscillator), the clock source for the state analyzer is the oscillator on the training board (Y1). When the CLK1 and CLK2 jumpers are set to P.G. (pattern generator), the clock source for the state analyzer is bit D7 or strobe 2 of the pattern generator, depending on which pattern generator pod is connected to J4.

The glitch is generated using the delay between the falling edge of D4 and rising edge of D5 of the ripple counter, and the delay using R2 with the input capacitance of the 74F02N. The ripple counter is a 74HC393. A 74F02 is used to generate the pulse (glitch) and combine it with D7 of the ripple counter. Because the 74F02 is a fast CMOS gate, it boosts the amplitude of the glitch it receives from the 74HC393 counter. This combination of logic families produces a positive glitch that is about 6 ns wide and has an amplitude of about 4 volts. The glitch is available on channel D7 of J1 and J2 when the GLITCH jumper is set to ON.

Jumpers

The jumpers are used to turn the glitch on and off and to select the sources for state clocks 1 (CLK1) and 2 (CLK2).

Glitch

When the GLITCH jumper is set to OFF, the waveform on D7 of J1 and J2 is the most significant bit of the counter. When this jumper is set to ON, a glitch appears on D7 and the waveform no longer represents the most significant bit of the counter. The glitch always appears on the test point labeled GLITCH, regardless of the position of this jumper.

CLK1

The CLK1 jumper selects the source of state clock 1. If you choose OSC (the default), the source of the clock will be the oscillator on the training board. If you choose P.G., the source of the clock will be Strobe 2 or D7 of the pattern generator, depending on which pattern generator pod you have connected to the training board.

CLK2

The CLK2 jumper selects the source of state clock 2 for the HP 16540A used in an HP 16500 system. If you choose OSC, the source of the clock will be the oscillator on the training board. If you choose P.G. (the default), the source of the clock will be Strobe 2 or D7 of the pattern generator, depending on which pattern generator pod you have connected to the training board.

All About the Logic Analyzer Training Board Schematic

Schematic

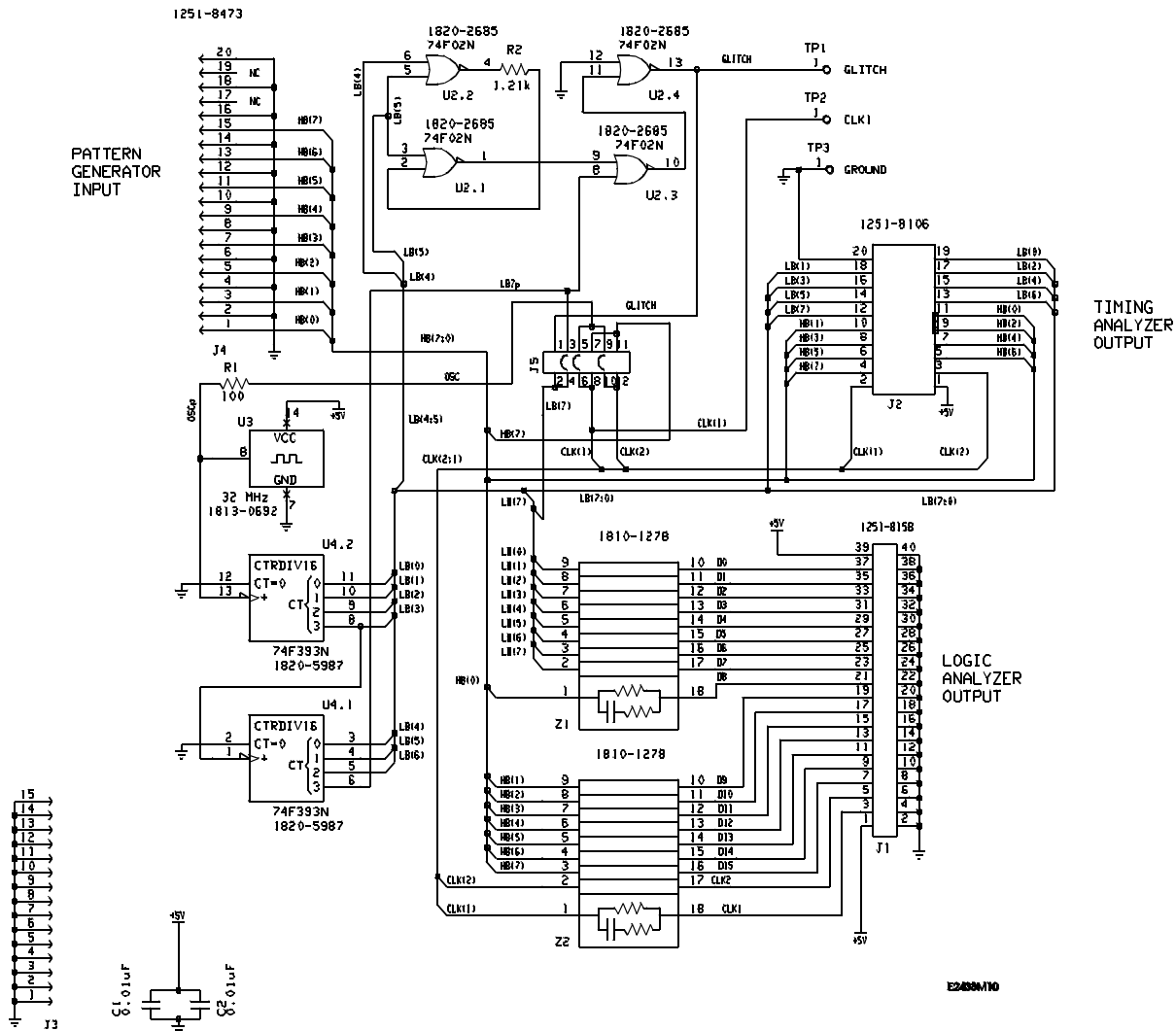

Logic Analyzer Training Board Schematic

Index

A

a thru j fields, 2-7, 3-8
activity indicators, 3-4
adding sequence levels, 6-7
adding symbols, 3-13
ADDR, DATA, STAT labels, 10-4
analysis
 state, 3-2
 timing, 2-2
analyzer mode
 set, 1-4
arming control, 5-9
 configuring, 1-6
 oscilloscope, 8-12
arming the oscilloscope, 8-12
arming the timing analyzer, 5-9
arrow keys, 1-3
arrows
 setting the state clock edge, 3-5
 showing activity in the pods, 3-4
assembly code, 10-2
 filter, 10-6
 listing, 10-5
assigning channels
 in the state analyzer, 3-7
 in the timing analyzer, 2-6
Autoscale, 7-5

B

base field, 2-7, 3-8
Boolean
 or function, 6-11 to 6-12

C

changing a label name, 2-5, 3-6
changing the jumper, 4-8
changing the oscilloscope trigger, 8-7
channel
 unused, 7-6
circuit description, 12-2
Clear Entry key, 2-6
CLK1, 12-2
CLK2, 12-2
clock
 edge, 3-5
 J through P, 3-5
 sample, 3-2
 source, 12-2
 state, 3-2

 state, set the, 3-5
Clock field
 setting the state clock, 3-5
combination term, 6-11 to 6-12
compare, 4-9
compare errors, 4-9
compare state listings, 4-2
complex sequence of states, 6-5
configuration
 loading, 11-4
configuration file
 to load a, 11-5 to 11-6
connecting the oscilloscope probe, 7-4
copying the state listing, 4-7
correlation of data, 5-2
count
 time, 5-8
counter
 ripple, 2-5
creating symbols, 3-12 to 3-13

D

defining a term, 2-7, 3-8
delay, 2-9
Delay field
 scanning the waveform, 7-7
deleting channels, 7-6
difference listing, 4-2, 4-9
disk menu, 11-5
"don't care", 5-7
down arrow, 3-5

E

errors
 compare, 4-9
 Find Error field, 4-9
exercises
 inverse assembly, 10-2
 mixed mode, 5-2
 multilevel state triggering, 6-2
 oscilloscope, 7-2
 state analyzer, 3-2
 state compare, 4-2
 timing analyzer, 2-2

F

field
 Autoscale, 7-5
 Trig to O, 7-8
 Trig to X, 7-8
front panel, 1-2

G

glitch
 capture, 8-14
 trigger, 8-11
glitch jumper, 4-8
Glitch/Edge term, 8-10
grouping bits, 1-5

H

highlighting a field, 1-3

I

immediate trigger mode, 8-7
indicators
 activity, 3-4
instruction types
 show, 10-6
 suppress, 10-6
Invasm, 10-5
inverse assembler
 loading, 10-3

J

J-clock, 3-4 to 3-5
jumpers
 CLK1, 12-3
 CLK2, 12-3
 default settings, 11-2
 glitch, 12-3
 setting, 11-3

L

label name
 changing, 2-5
labels, 2-5
 ADDR, DATA, STAT, 10-4
listing
 difference, 4-2, 4-9
 reference, 4-7
logic high, 2-2, 3-2
logic low, 2-2, 3-2

M

marker placement
 time-correlated, 5-10
 markers, 2-9, 5-10
 voltage, 7-10
 measuring the clock period
 Auto Measure, 7-9
 manually, 7-8
 mixed display, 5-10
 mixed mode, 5-2
 mixed mode exercises, 5-2
 modifying channel assignments, 2-6, 3-7
 multilevel state triggering, 6-2

O

O-Marker, 7-8
 oscilloscope
 connecting the probe, 7-2, 7-4
 exercises, 7-2

P

page keys, 3-11
 pattern
 duration, 2-8
 timing trigger, 2-7
 pattern generator, 9-2
 pattern generator format menu, 9-10, 9-11
 pod pair, 5-5
 pods, 3-5, 5-5
 assign, 1-4
 power source, 12-2
 Probe Assembly, 5-4
 probe leads, 5-4
 probes
 connect, 1-4
 program, "walking ones", 9-14
 programming the pattern generator, 9-12

R

range term, 6-6
 reading voltage, 7-10
 reference listing, 4-7
 ripple counter output, 6-15
 run, 2-9, 3-11
 single or repetitive, 1-7
 running the state analyzer, 3-11
 running the timing analyzer, 2-9

S

s/Div field, 2-9
 s/Dive field
 expanding the waveform, 7-7
 sample clock, 3-2
 scrolling, 1-3
 timing waveform, 2-9
 selecting a field, 1-2 to 1-3
 Sequence Level 1 pop-up
 setting up state trigger, 3-9
 sequence levels, 3-9
 adding, 6-7
 configuring, 6-8 to 6-12
 timing analyzer, 8-11
 setting up the state clock, 3-5
 setting up the trigger specification, 2-8
 show instructions, 10-6
 state analysis, 3-2
 state analyzer, 3-2
 running, 3-11
 state analyzer exercises, 3-2
 state compare exercises, 4-2
 state listing, 3-11
 viewing and changing, 3-11
 state mode, 3-4
 state trigger terms
 defining, 6-5
 storage qualification, 3-2, 6-15
 "store any state", 3-10
 stored states, 6-15
 suppress instructions, 10-6
 symbols, 3-12 to 3-13
 creating, 3-12 to 3-13
 viewing, 3-14

T

term
 combination, 6-11 to 6-12
 define, 3-8
 defining, 2-7
 Glitch/Edge, 8-10
 range, 6-6
 trigger, 2-7
 termination adapter, 5-4
 threshold, 2-2
 threshold voltage, 3-2
 time
 count, 5-8

stamp, 5-8

time correlated, 8-2
 time intervals, 2-2
 time-correlated marker placement, 5-10
 time-correlation, 5-8, 8-2
 timing
 analysis, 2-2
 Timing Acquisition Mode, 8-9, 9-9
 timing analyzer exercises, 2-2
 timing mode, 2-4
 Training Kit
 materials needed, 2-iv
 Trig to O field, 7-8
 Trig to X field, 2-9, 7-8
 trigger
 define a term, 2-7
 immediate, 8-7
 timing, 2-8
 trigger specification
 state, 3-9
 trigger term
 range, 6-6

U

unused channel
 deleting, 7-6
 using the analyzer
 interface, 1-2
 making a measurement, 1-2

V

voltage markers, 7-10
 voltage resolution, 2-2

W

waveform
 adding oscilloscope to timing, 8-13
 scrolling, 2-9
 zooming, 2-9
 "While storing no state", 4-5

X

X-Marker, 7-8

Z

zooming
 timing waveform, 2-9

Reproduction, adaptation, or translation without prior written permission is prohibited, except as allowed under the copyright laws.

Document Warranty

The information contained in this document is subject to change without notice.

Hewlett-Packard makes no warranty of any kind with regard to this material, including, but not limited to, the implied warranties of merchantability or fitness for a particular purpose.

Hewlett-Packard shall not be liable for errors contained herein or for damages in connection with the furnishing, performance, or use of this material.

Safety

This apparatus has been designed and tested in accordance with IEC Publication 348, Safety Requirements for Measuring Apparatus, and has been supplied in a safe condition. This is a Safety Class I instrument (provided with terminal for protective earthing). Before applying power, verify that the correct safety precautions are taken (see the following warnings). In addition, note the external markings on the instrument that are described under "Safety Symbols."

Warning

- Before turning on the instrument, you must connect the protective earth terminal of the instrument to the protective conductor of the (mains) power cord. The mains plug shall only be inserted in a socket outlet provided with a protective earth contact. You must not negate the protective action by using an extension cord (power cable) without a protective conductor (grounding). Grounding one conductor of a two-conductor outlet is not sufficient protection.
- Only fuses with the required rated current, voltage, and specified type (normal blow, time delay, etc.) should be used. Do not use repaired fuses or short-circuited fuseholders. To do so could cause a shock of fire hazard.

- Service instructions are for trained service personnel. To avoid dangerous electric shock, do not perform any service unless qualified to do so. Do not attempt internal service or adjustment unless another person, capable of rendering first aid and resuscitation, is present.
- If you energize this instrument by an auto transformer (for voltage reduction), make sure the common terminal is connected to the earth terminal of the power source.
- Whenever it is likely that the ground protection is impaired, you must make the instrument inoperative and secure it against any unintended operation.
- Do not operate the instrument in the presence of flammable gasses or fumes. Operation of any electrical instrument in such an environment constitutes a definite safety hazard.
- Do not install substitute parts or perform any unauthorized modification to the instrument.
- Capacitors inside the instrument may retain a charge even if the instrument is disconnected from its source of supply.
- Use caution when exposing or handling the CRT. Handling or replacing the CRT shall be done only by qualified maintenance personnel.

Safety Symbols



Instruction manual symbol: the product is marked with this symbol when it is necessary for you to refer to the instruction manual in order to protect against damage to the product.



Hazardous voltage symbol.



Earth terminal symbol: Used to indicate a circuit common connected to grounded chassis.

WARNING

The Warning sign denotes a hazard. It calls attention to a procedure, practice, or the like, which, if not correctly performed or adhered to, could result in personal injury. Do not proceed beyond a Warning sign until the indicated conditions are fully understood and met.

CAUTION

The Caution sign denotes a hazard. It calls attention to an operating procedure, practice, or the like, which, if not correctly performed or adhered to, could result in damage to or destruction of part or all of the product. Do not proceed beyond a Caution symbol until the indicated conditions are fully understood or met.

Product Warranty

This Hewlett-Packard product has a warranty against defects in material and workmanship for a period of one year from date of shipment. During the warranty period, Hewlett-Packard Company will, at its option, either repair or replace products that prove to be defective.

For warranty service or repair, this product must be returned to a service facility designated by Hewlett-Packard.

For products returned to Hewlett-Packard for warranty service, the Buyer shall prepay shipping charges to Hewlett-Packard and Hewlett-Packard shall pay shipping charges to return the product to the Buyer. However, the Buyer shall pay all shipping charges, duties, and taxes for products returned to Hewlett-Packard from another country.

Hewlett-Packard warrants that its software and firmware designated by Hewlett-Packard for use with an instrument will execute its programming instructions when properly installed on that instrument.

Hewlett-Packard does not warrant that the operation of the instrument software, or firmware will be uninterrupted or error free.

Limitation of Warranty

The foregoing warranty shall not apply to defects resulting from improper or inadequate maintenance by the Buyer, Buyer-supplied software or interfacing, unauthorized modification or misuse, operation outside of the environmental specifications for the product, or improper site preparation or maintenance.

No other warranty is expressed or implied. Hewlett-Packard specifically disclaims the implied warranties of merchantability or fitness for a particular purpose.

Exclusive Remedies

The remedies provided herein are the buyer's sole and exclusive remedies.

Hewlett-Packard shall not be liable for any direct, indirect, special, incidental, or consequential damages, whether based on contract, tort, or any other legal theory.

Assistance

Product maintenance agreements and other customer assistance agreements are available for Hewlett-Packard products.

For any assistance, contact your nearest Hewlett-Packard Sales Office.

Certification

Hewlett-Packard Company certifies that this product met its published specifications at the time of shipment from the factory. Hewlett-Packard further certifies that its calibration measurements are traceable to the United States National Institute of Standards and Technology, to the extent allowed by the Institute's calibration facility, and to the calibration facilities of other International Standards Organization members.

About this edition

This is the first edition of the *HP E2433-60012 Training Kit for HP 1660/70 Series Logic Analyzers Training Guide*.

Publication number
E2433-97034

Printed in USA.

Edition dates are as follows:
First edition, November 1997

New editions are complete revisions of the manual. Update packages, which are issued between editions, contain additional and replacement pages to be merged into the manual by you. The dates on the title page change only when a new edition is published.

A software or firmware code may be printed before the date. This code indicates the version level of the software or firmware of this product at the time the manual or update was issued. Many product updates do not require manual changes; and, conversely, manual corrections may be done without accompanying product changes. Therefore, do not expect a one-to-one correspondence between product updates and manual updates.

The following list of pages gives the date of the current edition and of any changed pages to that edition.

All pages original edition