

## Errata

**Title & Document Type:** 3466A Digital Multimeter Operating and Service Manual

**Manual Part Number:** 03466-90003

**Revision Date:** January 1984

---

### HP References in this Manual

This manual may contain references to HP or Hewlett-Packard. Please note that Hewlett-Packard's former test and measurement, semiconductor products and chemical analysis businesses are now part of Agilent Technologies. We have made no changes to this manual copy. The HP XXXX referred to in this document is now the Agilent XXXX. For example, model number HP8648A is now model number Agilent 8648A.

### About this Manual

We've added this manual to the Agilent website in an effort to help you support your product. This manual provides the best information we could find. It may be incomplete or contain dated information, and the scan quality may not be ideal. If we find a better copy in the future, we will add it to the Agilent website.

### Support for Your Product

Agilent no longer sells or supports this product. You will find any other available product information on the Agilent Test & Measurement website:

[www.tm.agilent.com](http://www.tm.agilent.com)

Search for the model number of this product, and the resulting product page will guide you to any available information. Our service centers may be able to perform calibration if no repair parts are needed, but no other support from Agilent is available.

# OPERATING AND SERVICE MANUAL

# DIGITAL MULTIMETER 3466A

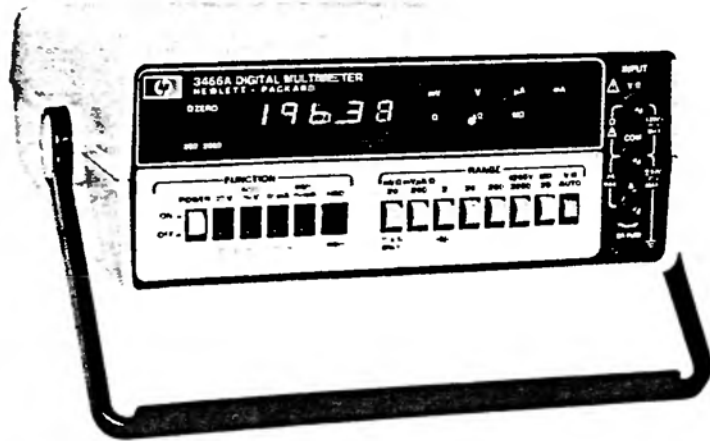

# **OPERATING AND SERVICE MANUAL 3466A DIGITAL MULTIMETER**

**Serial Numbers 1716A18811 and Above**

## **IMPORTANT**

If the serial number of your instrument is lower than shown on this Title Page, the manual contains information that do not apply to your instrument. Refer to Section VII of this manual for backdating information to adapt this manual to earlier instruments.

## **WARNING**

*To help minimize the possibility of electrical fire or shock hazards, do not expose this instrument to rain or excess moisture.*

**Manual Part No. 03466-90003**

**Microfiche Part No. 03466-90053**

©Copyright Hewlett-Packard Company 1977  
P.O. Box 301, Loveland, Colorado 80537 U.S.A.

# hp MANUAL CHANGES

-hp- MODEL 3466A

DIGITAL MULTIMETER

Manual Part Number 03466-90003

## ERRATA

**Page 6-7, Table 6-3 (Replaceable Parts).** Change the part number of the A3 Assembly from "03435-66803" to "03435-66503".

**Page 7-4, Paragraph 7-40.** Change the part number of A1Q101 in the second sentence of the paragraph from "1855-0449" to "1855-0469".

**Pages 8-29, 8-31, 8-33, and 8-37.** Do the following changes on the component locator (on apron pages).

Change the A1 Assembly part number from "03466-66501" to "03466-66577".

Change the reference designation of "R210" to "R120"

Change the reference designation of "C112" to "C100"

**Pages 8-29, 8-31, 8-33, 8-35, and 8-37.** Change the A1 Assembly part number on Schematics 1, 2, 3, 4, and 5 from "03466-66501 or 03466-66516" to "03466-66577".

**Page 8-29, Schematic 1.** Do the following changes on the schematic:

Add "1A DC ADJ." to variable resistor R660.

Connect the DC path to R128 instead of U102(21).

**Page 8-31, Schematic 2.** Do the following changes on the schematic.

On the apron page, add the following components to the Component Locator table.

Component	Location
C112	G,H1
R120	E,F1

Change the value of R108 from "6.98K" to "4.99K".

**Page 8-35, Schematic 4.** Do the following changes on the schematic.

Change the A4 Assembly part number from "03466-66504" to "03466-66514".

Change the A2 Assembly part number from "03466-66502" to "03466-66578".

**Page 8-29, Schematic 1.** Do the following wire color code changes on the schematic.

Location	Change Color Code	
	From	To
DC Path	5	1
S2(7)	7	1
S2(11)	9	2

**Page 8-31, Schematic 2.** Change the color code of the wire connected at U102(15) and from "8" to "1".

**Page 8-33, Schematic 3.** Change the color code of the wire connected at U402(30) from "8" to "1".

### CHANGE NO. 1. Applies to ALL Serial Numbers

**Page 1-5, Table 1-4 (Accessories).** Change the "Test lead kit" in the table from No. 11067A to No. 34118A.

**Page 6-6, Table 6-3 (Replaceable Parts).** Add the following part number to the table:

Reference Designation	HP Part Number	C D	Description
A2DSM1 thru DSM5	5180-0234	9	5 Displays with same Brightness Code

### CHANGE NO. 2. Applies to Serial Numbers 1716A19896 and above

**Pages 8-29, 8-31, 8-33, and 8-37.** Change the wiring and wire color codes on the component locators as shown in Figure C-1.

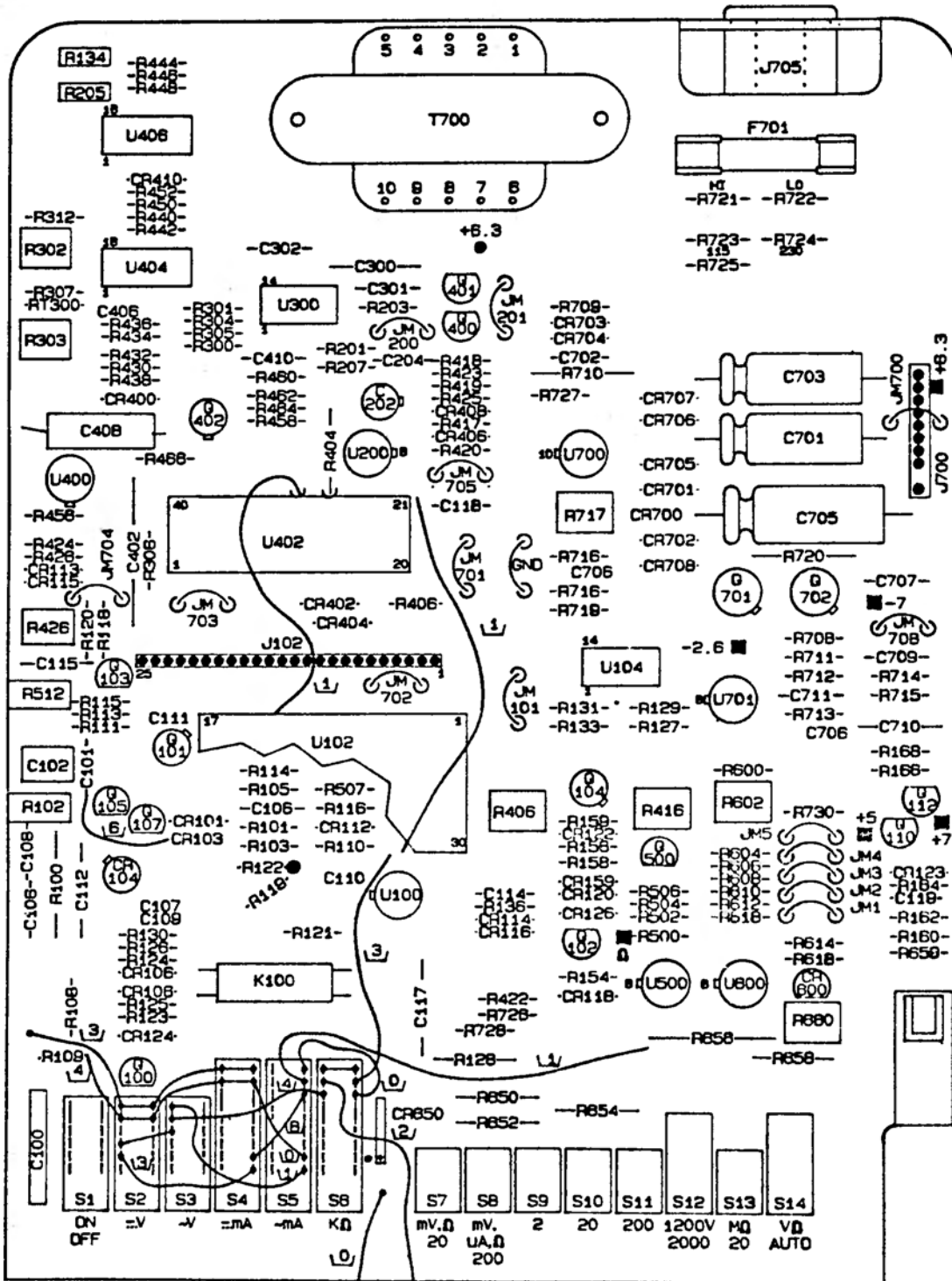

**A1**  
**03466-66577**  
**Rev. C**

**Figure C-1. Wire Color Code Changes**

## SAFETY SYMBOLS

### General Definitions of Safety Symbols Used On Equipment or In Manuals.



Instruction manual symbol: the product will be marked with this symbol when it is necessary for the user to refer to the instruction manual in order to protect against damage to the instrument.



Indicates dangerous voltage (terminals fed from the interior by voltage exceeding 1000 volts must be so marked).

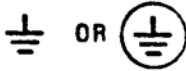

Protective conductor terminal. For protection against electrical shock in case of a fault. Used with field wiring terminals to indicate the terminal which must be connected to ground before operating equipment.



Low-noise or noiseless, clean ground (earth) terminal. Used for a signal common, as well as providing protection against electrical shock in case of a fault. A terminal marked with this symbol must be connected to ground in the manner described in the installation (operating) manual, and before operating the equipment.

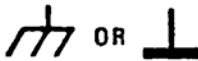

Frame or chassis terminal. A connection to the frame (chassis) of the equipment which normally includes all exposed metal structures.



Alternating current (power line).



Direct current (power line).



Alternating or direct current (power line).



The WARNING sign denotes a hazard. It calls attention to a procedure, practice, condition or the like, which, if not correctly performed or adhered to, could result in injury or death to personnel.



The CAUTION sign denotes a hazard. It calls attention to an operating procedure, practice, condition or the like, which, if not correctly performed or adhered to, could result in damage to or destruction of part or all of the product.

NOTE:

The NOTE sign denotes important information. It calls attention to procedure, practice, condition or the like, which is essential to highlight.

## TABLE OF CONTENTS

Section	Page
<b>I. GENERAL INFORMATION</b> .....	1-1
1-1. Introduction .....	1-1
1-3. Description .....	1-1
1-5. Specifications .....	1-1
1-7. Instrument and Manual Identification .....	1-1
1-9. Options .....	1-1
1-12. Accessories .....	1-1
1-14. Safety Considerations.....	1-1

Section	Page
<b>II. INSTALLATION</b> .....	2-1
2-1. Introduction .....	2-1
2-3. Initial Inspection.....	2-1
2-5. Power Requirements.....	2-1
2-7. Environmental Requirements.....	2-1
2-9. Repackaging For Shipment.....	2-1
2-13. Power Cords and Receptacles.....	2-1

Section	Page
<b>III. OPERATING INSTRUCTIONS</b> .....	3-1
3-1. Introduction .....	3-1
3-3. AC Operation.....	3-1
3-5. Battery Operation.....	3-1
3-10. Overload/Overage/Improper Function Indication.....	3-1
3-13. Auto.....	3-2
3-16. Input Terminals.....	3-2
3-20. DC Voltage Measurements.....	3-2
3-21. Procedure .....	3-2
3-22. AC Voltage Measurements.....	3-3
3-23. Procedure .....	3-3
3-24. True RMS (dc + ac) Voltage Measurements.....	3-3
3-25. Procedure .....	3-3
3-26. DC Current Measurement.....	3-3
3-27. Procedure .....	3-4
3-28. AC Current Measurements.....	3-4
3-29. Procedure .....	3-4
3-30. True RMS (dc + ac) Current Measurements.....	3-4
3-31. Procedure .....	3-4
3-32. Resistance Measurements.....	3-4
3-34. Procedure .....	3-5
3-35. Diode Test.....	3-5
3-37. Handle/Bail .....	3-5
3-39. Option Decal.....	3-5
3-41. Information Decal.....	3-5
3-43. Amps Input Fuse Replacement.....	3-6
3-45. Multimeter Cleaning.....	3-6

Section	Page
<b>IV. PERFORMANCE TESTS</b> .....	4-1
4-1. Introduction .....	4-1
4-3. Required Equipment.....	4-1
4-5. Test Cards.....	4-1
4-7. Warm-Up Time.....	4-1

Section	Page
<b>IV. PERFORMANCE TESTS (Cont'd)</b>	
4-9. Performance Tests.....	4-1
4-11. DC Voltmeter Accuracy Test.....	4-2
4-14. AC Voltmeter Accuracy Test.....	4-3
4-17. True RMS Voltmeter Accuracy Test .....	4-4
4-20. DC Ammeter Accuracy Test.....	4-5
4-23. AC Ammeter Accuracy Test.....	4-6
4-26. True RMS Ammeter Accuracy Test .....	4-7
4-29. Ohmmeter Accuracy Test.....	4-8
4-32. AC Normal Mode Rejection Test (NMRR).....	4-9
4-36. AC Common Mode Rejection Test (CMRR).....	4-10
4-40. DC Common Mode Rejection Test (DCV CMRR).....	4-10

Section	Page
<b>V. ADJUSTMENTS</b> .....	5-1
5-1. Introduction .....	5-1
5-3. Equipment Required.....	5-1
5-5. Adjustment Interval.....	5-1
5-7. Pre-Adjustment Information.....	5-2
5-9. Instrument Disassembly Instructions.....	5-2
5-11. Test Points and Adjustment Locations .....	5-2
5-13. Adjustment Procedures.....	5-2
5-15. ① +7V Power Supply Adjustment (R717) .....	5-2
5-18. Battery Charge Voltage Adjustment (R818).....	5-2
5-21. ② Input Amplifier and ③ Post Amplifier Zero Adjustments (R152 and R205).....	5-3
5-24. ④ 19k ohms, ⑤ 19 ohms, and ⑥ 10M ohms Adjustments (R416, R926/R406, and R428).....	5-3
5-27. ⑦ 19V DC Adjustment (R602).....	5-3
5-32. 2V DC Zero Offset Adjustment (R118*/R120*).....	5-4
5-34. ⑧ Zero Input DC Adjustment (R134).....	5-5
5-36. ⑨ 19V AC 200Hz and ⑩ 1.9V AC 200Hz Adjustments (R303 and R302).....	5-5
5-39. ⑪ A and ⑫ B True RMS Con- verter Adjustments (R308/R309).....	5-5
5-43. ⑬ 19V AC 10kHz and ⑭ 1.9V AC 10kHz Adjustments (R102 and C102).....	5-5
5-46. ⑮ 100kHz Frequency Response Adjustment (C202).....	5-6
5-49. 1A DC Adjustment (R660).....	5-6
5-52. Power Requirement Modification Instructions.....	5-6



## SAFETY SUMMARY

The following general safety precautions must be observed during all phases of operation, service, and repair of this instrument. Failure to comply with these precautions or with specific warnings elsewhere in this manual violates safety standards of design, manufacture, and intended use of the instrument. Hewlett-Packard Company assumes no liability for the customer's failure to comply with these requirements. This is a Safety Class 1 instrument.

### GROUND THE INSTRUMENT

To minimize shock hazard, the instrument chassis and cabinet must be connected to an electrical ground. The instrument is equipped with a three-conductor ac power cable. The power cable must either be plugged into an approved three-contact electrical outlet or used with a three-contact to two-contact adapter with the grounding wire (green) firmly connected to an electrical ground (safety ground) at the power outlet. The power jack and mating plug of the power cable meet International Electrotechnical Commission (IEC) safety standards.

### DO NOT OPERATE IN AN EXPLOSIVE ATMOSPHERE

Do not operate the instrument in the presence of flammable gases or fumes. Operation of any electrical instrument in such an environment constitutes a definite safety hazard.

### KEEP AWAY FROM LIVE CIRCUITS

Operating personnel must not remove instrument covers. Component replacement and internal adjustments must be made by qualified maintenance personnel. Do not replace components with power cable connected. Under certain conditions, dangerous voltages may exist even with the power cable removed. To avoid injuries, always disconnect power and discharge circuits before touching them.

### DO NOT SERVICE OR ADJUST ALONE

Do not attempt internal service or adjustment unless another person, capable of rendering first aid and resuscitation, is present.

### DO NOT SUBSTITUTE PARTS OR MODIFY INSTRUMENT

Because of the danger of introducing additional hazards, do not install substitute parts or perform any unauthorized modification to the instrument. Return the instrument to a Hewlett-Packard Sales and Service Office for service and repair to ensure that safety features are maintained.

### DO NOT OPERATE A DAMAGED INSTRUMENT

Whenever it is possible that the safety protection features built into this instrument have been impaired, either through physical damage, excessive moisture, or any other reason, REMOVE POWER and do not use the instrument until safe operation can be verified by service-trained personnel. If necessary, return the instrument to a Hewlett-Packard Sales and Service Office for service and repair to ensure that safety features are maintained.

### DANGEROUS PROCEDURE WARNINGS

Warnings, such as the example below, precede potentially dangerous procedures throughout this manual. Instructions contained in the warnings must be followed.

**WARNING**

Dangerous voltages, capable of causing death, are present in this instrument. Use extreme caution when handling, testing, and adjusting.

A



## TABLE OF CONTENTS (Cont'd)

Section	Page	Section	Page
VI. REPLACEABLE PARTS.....	6-1	VII. BACKDATING (Cont'd)	
6-1. Introduction.....	6-1	7-39. Change #13 (Serial Numbers 1716A12146 and Below).....	7-4
6-4. Ordering Information.....	6-1	7-42. Change #14 (Serial Numbers 1716A13915 and Below).....	7-4
6-6. Non-Listed Parts.....	6-1	7-44. Change #15 (Serial Numbers 1716A14170 and Below).....	7-4
6-8. Parts Changes.....	6-1	7-47. Change #16 (Serial Numbers 1716A17005 and Below).....	7-5
6-10. Proprietary Parts.....	6-2	7-52. Change #17 (Serial Numbers 1716A18810 and Below).....	7-5
Section	Page	Section	Page
VII. BACKDATING.....	7-1	VIII. SERVICE.....	8-1
7-1. Introduction.....	7-1	8-1. Introduction.....	8-1
7-3. Manual Changes.....	7-1	8-4. Theory of Operation.....	8-1
7-6. Change #1 (Serial Numbers 1716A00450 and Below).....	7-1	8-5. Block Diagram and Simplified Theory.....	8-1
7-8. Change #2 (Serial Numbers 1716A00525 and Below).....	7-1	8-18. Detailed Theory.....	8-2
7-14. Change #3 (Serial Numbers 1716A01580 to 1716A00451).....	7-2	8-47. Analog Theory of Operation.....	8-7
7-17. Change #4 (Serial Numbers 1716A01638 to 1716A00451).....	7-2	8-72. Troubleshooting.....	8-11
7-19. Change #5 (Serial Numbers 1716A01830 and Below).....	7-2	8-74. Equipment Required.....	8-12
7-21. Change #6 (Serial Numbers 1716A02330 and Below).....	7-2	8-76. Instrument Disassembly.....	8-12
7-23. Change #7 (Serial Numbers 1716A02780 and Below).....	7-3	8-78. General Troubleshooting Information.....	8-12
7-27. Change #8 (Serial Numbers 1716A02980 and Below).....	7-4	8-80. Failure Isolation.....	8-13
7-30. Change #9 (Serial Numbers 1716A03380 and Below).....	7-4	8-85. Power Supplies Troubleshooting...	8-14
7-33. Change #10 (Serial Numbers 1716A04380 to 1716A01331).....	7-4	8-88. Battery Charger Assembly Troubleshooting.....	8-15
7-35. Change #11 (Serial Numbers 1716A05530 and Below).....	7-4	8-94. Internal Clock Troubleshooting...	8-16
7-37. Change #12 (Serial Number 1716A11460 to 1716A01831).....	7-4	8-96. Function and Range Select Troubleshooting.....	8-16
		8-100. Digital Troubleshooting.....	8-16
		8-106. DC Troubleshooting.....	8-19
		8-113. Ohms Troubleshooting.....	8-21
		8-121. AC Troubleshooting.....	8-22

## LIST OF TABLES

Table	Page	Table	Page
1-1. Specifications.....	1-2	4-9. Complete DC Ammeter Accuracy Test.....	4-5
1-2. General Information.....	1-4	4-10. AC Ammeter Accuracy Test (200 $\mu$ A to 20mA Ranges).....	4-7
1-3. Options.....	1-5	4-11. AC Ammeter Accuracy Test (200mA and 2000mA Ranges).....	4-7
1-4. Accessories.....	1-5	4-12. True RMS Ammeter Accuracy Test.....	4-8
3-1. Improper Switch Combinations.....	3-2	4-13. Abbreviated Ohmmeter Accuracy Test.....	4-8
4-1. Required Test Equipment.....	4-1	4-14. Complete Ohmmeter Accuracy Test.....	4-9
4-2. Abbreviated DC Voltmeter Accuracy Test...	4-2	5-1. Required Test Equipment.....	5-1
4-3. Complete DC Voltmeter Accuracy Test.....	4-2	5-2. Power Supply Voltage Checks.....	5-2
4-4. Abbreviated AC Voltmeter Accuracy Test...	4-3	5-3. 19V DC Coarse Adjustment.....	5-4
4-5. Complete AC Voltmeter Accuracy Test.....	4-3	5-4. R118* and R120* Selection.....	5-5
4-6. Abbreviated True RMS Voltmeter Accuracy Test.....	4-4	6-1. Standard Abbreviations.....	6-1
4-7. Complete True RMS Voltmeter Accuracy Test.....	4-4	6-2. Code List of Manufacturers.....	6-2
4-8. Abbreviated DC Ammeter Accuracy Test...	4-5	6-3. Replaceable Parts.....	6-3

## LIST OF TABLES (Cont'd)

Table	Page	Table	Page
6-4. Mechanical and Miscellaneous Parts.....	6-10	8-4. Power Supply Voltages.....	8-14
6-5. Option 002 Miscellaneous Parts.....	6-12	8-5. 3466A Self-Test (+ 1V Input).....	8-18
7-1. Manual Changes.....	7-1	8-6. A/D Converter and Amplifiers Waveforms.....	8-19
7-2. Changes in Table 6-3 (Change #2).....	7-1	8-7. DC Gain.....	8-21
8-1. Function Code.....	8-7	8-8. Ohms Current Source.....	8-22
8-2. Range Codes.....	8-7	8-9. AC Gain.....	8-23
8-3. Equipment Required.....	8-12		

## LIST OF ILLUSTRATIONS

Figure	Page	Figure	Page
2-1. Power Receptacles.....	2-0	7-1. Schematics 1, 2, and 3 Changes (Change #2).....	7-2
3-1. Description of Controls and Connectors.....	3-0	7-2. Component Locator for Changes #2, 7, and 16.....	7-3
3-2. Battery Voltage Access Hole.....	3-1	7-3. Schematic 4 Changes (Change #3).....	7-3
3-3. Overload Indication.....	3-1	7-4. Schematic 2 Changes (Change #8).....	7-4
3-4. Multimeter Autoranging.....	3-2	7-5. Component Locator for Change #14.....	7-5
3-5. DC Voltage Measurements.....	3-3	7-6. Schematics 2 and 5 Changes (Change #16)...	7-5
3-6. AC Voltage Measurement.....	3-3	7-7. Component Locator for Change #17.....	7-6
3-7. True RMS (dc + ac) Voltage Measurements.....	3-3	8-1. Simplified Block Diagram.....	8-1
3-8. DC Current Measurements.....	3-4	8-2. -7V Regulator.....	8-2
3-9. AC Current Measurement.....	3-4	8-3. 5V Reference Supply Simplified Schematic.....	8-3
3-10. True RMS Current Measurement.....	3-4	8-4. Battery Charger.....	8-4
3-11. Resistance Measurement.....	3-5	8-5. Converter Control Logic.....	8-5
3-12. Diode Test.....	3-5	8-6. Low Battery Indicator.....	8-5
3-13. Handle/Bail Positioning.....	3-5	8-7. Converter Block Diagram.....	8-6
3-14. Option Decal and Ohms Zero Adjust.....	3-6	8-8. Turn-On Circuit.....	8-6
3-15. Information Decal.....	3-6	8-9. Range Code Logic Interface.....	8-7
4-1. DC Voltmeter Accuracy Test.....	4-2	8-10. DC Gain Configuration.....	8-8
4-2. AC Voltmeter Accuracy Test.....	4-4	8-11. AC Gain Configurations.....	8-9
4-3. True RMS Voltmeter Accuracy Test.....	4-5	8-12. Ohms Block Diagram.....	8-9
4-4. DC Ammeter Accuracy Test.....	4-6	8-13. Ohm Gain.....	8-10
4-5. AC Ammeter Accuracy Test (200 $\mu$ A to 20mA Ranges).....	4-7	8-14. Integrator Output.....	8-11
4-6. AC Ammeter Accuracy Test (200mA and 2000mA Ranges).....	4-7	8-15. 3466A Self-Test Connection.....	8-17
4-7. True RMS Ammeter Accuracy Test.....	4-8	8-16. Logic Interface Block Diagram.....	8-25
4-8. Ohms Accuracy Test.....	4-9	8-17. Simplified Analog Schematic.....	8-27
4-9. AC Normal Mode Rejection Test.....	4-9	8-18. Input Switching Schematic.....	8-29
4-10. AC Common Mode Rejection Test.....	4-10	8-19. Ohms Current Source and Input Amplifier Schematic.....	8-31
4-11. DC Common Mode Rejection Test.....	4-11	8-20. Post Amplifier, TRMS Converter, and Analog to Digital Converter Schematic...	8-33
5-1. Line Voltage Configuration.....	5-6	8-21. Logic and Display Schematic.....	8-35
5-2. Adjustment Locator.....	5-7	8-22. Power Supply and Charger Schematic.....	8-37
6-1. 3466A Exploded View (Refer to Table 6-4).....	6-11		

# SECTION I

## GENERAL INFORMATION

### 1-1. INTRODUCTION

1-2. This section contains general information concerning the -hp- Model 3466A Multimeter. Included is an instrument description, specifications, information about instrument and manual identification, option and accessory information, and safety considerations.

### 1-3. DESCRIPTION

1-4. The -hp- Model 3466A is a 4½ digit, seven function, autoranging multimeter. The functions are AC or DC Voltage, AC or DC Current, AC + DC Voltage, AC + DC Current and Ohms. All seven functions have manually selectable ranges. AC Voltage, DC Voltage, AC + DC Voltage and Ohms functions may also be automatically ranged by pressing the AUTO pushbutton. Throughout the remainder of this manual, the -hp- Model 3466A Multimeter will be referred to as Multimeter.

### 1-5. SPECIFICATIONS

1-6. Specifications for the Multimeter are listed in Table 1-1. These specifications are the performance standards or limits to which the Multimeter can be tested. Any changes in these specifications due to manufacturing changes, design or traceability to the National Bureau of Standards will be covered by an errata or change sheet. These specifications supersede any prior published specifications. Supplemental information in Table 1-2 is provided to describe general operating characteristics.

### 1-7. INSTRUMENT AND MANUAL IDENTIFICATION

1-8. Hewlett-Packard uses a two-section serial number. The first section (prefix) identifies a series of instruments. The last section (suffix) identifies a particular instrument within the series. A letter between the prefix and the suffix identifies the country in which the instrument was manufactured. The manual is kept up-to-date at all times by means of a change sheet which is supplied with the manual. If the serial number of your instrument differs from the one on the title page of this manual, refer to

the change sheet supplied with the manual. All correspondence with Hewlett-Packard should include the complete serial number.

### 1-9. OPTIONS

1-10. Table 1-3 lists the option available for the Multimeter.

1-11. The option label affixed to the rear of the Multimeter identifies the line voltage for which the instrument is wired. This operating voltage can be changed by following the procedure outlined in Section V (Power Requirement Modification Instructions). If the line voltage option is changed, the option label should also be corrected to reflect the new configuration.

#### NOTE

*Option 001 Multimeters can be converted to standard instruments by adding the battery and charger circuitry. The Battery/Charger kit to convert the instruments can be ordered under Part Number 03438-80001.*

### 1-12. ACCESSORIES

1-13. The accessories available for use with the Multimeter are listed in Table 1-4.

### 1-14. SAFETY CONSIDERATIONS



1-15. This Operating and Service Manual contains cautions and warnings alerting the user to hazardous operating and maintenance conditions. This information is flagged by a caution or warning heading and/or the symbol . The  symbol appears on the front panel and is an international symbol meaning "refer to the Operating and Service Manual". This symbol flags important operating instruction located in Section III. To ensure the safety of the operating and maintenance personnel and retain the operating condition of the instrument, these instructions must be followed.

Table 1-1. Specifications

**DC VOLTMETER**

Accuracy: (for 1 year at 23°C ± 5°C):

Range	Max. Display	Accuracy
20mV	± 19.999mV	± (.05% of reading + 3 digits)
200mV	± 199.99mV	± (.04% of reading + 2 digits)
2V	± 1.9999V	± (.03% of reading + 1 digit)
20V	± 19.999V	± (.03% of reading + 1 digit)
200V	± 199.99V	± (.03% of reading + 1 digit)
1200V	± 1199.9V	< 700V, ± (.035% of reading + 1 digit)
1200V	± 1199.9V	> 700V, ± (.055% of reading + 1 digit)

Maximum Input: ± 1200V (dc + peak ac).

Ranging: Automatic or Manual.

Input Type: Floating (500V max. from COM to earth ground).

Input Resistance: 10MΩ ± 0.5% (all ranges).

Sensitivity: 1μV on the 20mV range.

Polarity: Automatically sensed and displayed.

Response Time: < 0.7 seconds to within 1 digit of final value on one range. Add 0.8 seconds for each range change.

Temperature Coefficient: ± (.003% of reading + 0.15 Digits)/°C (0°C to 18°C and 28°C to 55°C).

Normal Mode Rejection: > 54dB at 50/60Hz ± 0.1%.

Effective Common-Mode Rejection: ≥ 140dB at dc; 120dB at 50/60Hz ± .1% (1kΩ imbalance).

**AC VOLTMETER (TRUE RMS)**

AC Converter: True RMS

Range	Max. Display
200mV	199.99mV
2V	1.999V
20V	19.999V
200V	199.99V
1200V	1199.9V

Accuracy: (for 1 year at 23°C ± 5°C and at > 1900 digits):

Frequency	Accuracy (all ranges)
20 Hz – 30 Hz	± (2% of reading + 50 digits)
30 Hz – 50 Hz	± (1% of reading + 30 digits)
50 Hz – 20kHz	± (0.3% of reading + 20 digits)
20kHz – 50kHz	± 1% of reading + 40 digits)
50kHz – 100kHz	± (2% of reading + 150 digits)

Maximum Input: 600Vdc or 1700 (dc + peak ac), 10<sup>7</sup>V Hz.

Ranging: Automatic or Manual.

Input Type: Floating (500V max. from COM to earth ground).

Input Impedance: Resistance: 2M ohms ± 1.5%  
Shunt Capacitance: < 75pF

Sensitivity: 10μV on the 200mV range.

Response time: < 4.5 seconds to within 4 digits of final value on one range. Add 1.2 seconds for each range change.

Temperature Coefficient: (0°C to 18°C and 28°C to 55°C):

Frequency	Temperature Coefficient (all ranges)
20Hz to 30Hz and 50kHz to 100kHz	± (.05% of reading + 15 digits)/°C
30Hz to 50Hz and 20kHz to 50kHz	± (.05% of reading + 2 digits)/°C
50Hz to 20kHz	± (.03% of reading + .5 digits)/°C

Maximum Crest Factor: 4 to 1

**DC + AC VOLTMETER (TRUE RMS)**

Range	Max. Display
200mV	199.99mV
2V	1.9999V
20V	19.999V
200V	199.99V
1200V	1199.9V

Accuracy: (for 1 year at 23°C ± 5°C and at > 1900 digits):

DC + 20 Hz to 50kHz	± (1% of reading + 80 digits)
DC + 50kHz to 100kHz	± (2% of reading + 200 digits)

Maximum Input: 1200Vdc or 1700V (dc + peak ac), 10<sup>7</sup>VHz

Ranging: Automatic or Manual.

Input Type: Floating (500V max. from COM to earth ground).

Input Impedance: Resistance: 2M ohms ± 1.5%  
Shunt Capacitance: < 75pF

Sensitivity: 10μV on the 200mV range.

Response Time: < 4.5 seconds to within 4 digits of final value on one range. Add 1.2 seconds for each range change.

Temperature Coefficient: (0°C to 18°C and 28°C to 55°C):

Frequency	Temperature Coefficient *For all ranges except 200mV
DC + (50Hz to 20kHz)	± (.03% of reading + 6 digits)/°C
DC + (30Hz to 50Hz and 20kHz to 50kHz)	± (.05% of reading + 6 digits)/°C
DC + (20Hz to 30Hz and 50kHz to 100kHz)	± (.05% of reading + 10 digits)/°C

\*Add 5 digits/°C for the 200mV range.

**Table 1-1. Specifications (Cont'd)**

**DC AMMETER**

Accuracy: (for 1 year at 23°C ± 5°C):

Range	Max. Display	Shunt Resistance	Accuracy
200µA	199.99µA	1000Ω	±(.07% of reading + 2 digits)
2mA	1.9999mA	100Ω	±(.07% of reading + 2 digits)
20mA	19.999mA	10Ω	±(.07% of reading + 2 digits)
200mA	199.99mA	1Ω	±(.15% of reading + 2 digits)
2000mA	1999.9mA	0.1Ω	±(.5% of reading + 2 digits)

Maximum Input: ± 2 Amps from ≤250V Source.

Ranging: Manual only.

Input Type: Floating (500V max. from COM to earth ground).

Sensitivity: 10nA on the 200µA range.

Polarity: Automatically sensed and displayed.

Temperature Coefficient: (0°C to 18°C and 28°C to 55°C):

Range	Temperature Coefficient
200µA thru 20mA	±(.004% of reading + .15 digits)/°C
200mA thru 2000mA	±1.01% of reading + .15 digits)/°C

Voltage Burden:

Range	Max. Burden at Full Scale
200µA thru 20mA	<220mV
200mA	<240mV
2000mA	<600mV

**AC AMMETER (TRUE RMS)**

Range	Max. Display
200µA	199.99µA
2mA	1.9999mA
20mA	19.999mA
200mA	199.99mA
2000mA	1999.9mA

Sinewave Accuracy: (for 1 year at 23°C ± 5°C and at > 1900 digits):

Range	Frequency	Accuracy
200µA thru 200mA	20Hz to 30 Hz	±(2% of reading + 50 digits)
	30Hz to 10kHz	±1.9% of reading + 35 digits)
2000mA	20Hz to 30 Hz	±(2% of reading + 50 digits)
	30Hz to 10kHz	±(1.2% of reading + 20 digits)

Minimum Display: 1900 digits.

Maximum Input: 2 Amps rms from ≤250V rms source.

Ranging: Manual only.

Input Type: Floating (500V max. from COM to earth ground).

Input Protection; 2A, 250V Fuse.

Sensitivity: 10nA on the 200µA range.

Temperature Coefficient: (0°C to 18°C and 28°C to 55°C):

Range	Temperature Coefficient
200µA thru 200mA	±(.03% of reading + .5 digits)/°C
2000mA	±(.04% of reading + .5 digits)/°C

Maximum Crest Factor: 4 to 1

Voltage Burden:

Range	Max. Burden at Full Scale
200µA thru 20mA	<220mV rms
200mA	<240mV rms
2000mA	<600mV rms

**DC + AC AMMETER (TRUE RMS)**

Range	Max. Display
200µA	199.99µA
2mA	1.9999mA
20mA	19.999mA
200mA	199.99mA
2000mA	1999.9mA

Accuracy: (for 1 year at 23°C ± 5°C

Range	Frequency	Accuracy
200µA thru 2000mA	DC + 20Hz to 10kHz	±(1.5% of reading + 80 digits)

Minimum Display: 1900 digits.

Maximum Input: 2 Amps rms from ≤250V rms source.

Ranging: Manual only.

Input Type: Floating (500V max. from COM to earth ground).

Input Protection; 2A, 250V Fuse.

Sensitivity: 10nA on the 200µA range.

Response Time: <4.5 seconds to within 4 digits of final value.

Temperature Coefficient: ±.03% of reading + 20 digits/°C (0°C to 18°C and 28°C to 55°C):

Maximum Crest Factor: 4 to 1

Table 1-1. Specifications (Cont'd)



<b>Voltage Burden:</b>		<b>Sensitivity:</b> 1mΩ on the 20Ω range.	
<b>Range</b>	<b>Max. Burden at Full Scale</b>	<b>Output Voltage:</b> <5 volts dc.	<b>Overload Protection:</b> 350V (dc + peak ac).
200μA thru 20mA	<220mV rms	<b>Temperature Coefficient:</b> (0°C to 18°C and 28°C to 55°C):	
200mA	<240mV rms		
2000mA	<600mV rms		
<b>OHMMETER</b>		<b>Range</b>	<b>Temperature Coefficient</b>
<b>Accuracy:</b> (for 1 year at 23°C ± 5°C):		20Ω thru 2MΩ	± (.002% of reading + .05 digits)/°C
		20MΩ	± (.01% of reading + .1 digits)/°C
<b>Range</b>	<b>Max. Display</b>	<b>Voltage at 10000 Digits</b>	<b>Output Current</b>
20Ω	19.999Ω	5mV	5mA
200Ω	199.99Ω	500mV	5mA
2kΩ	1.9999Ω	1V	1mA
20kΩ	19.999kΩ	1V	100μA
200kΩ	199.99kΩ	1V	10μA
2MΩ	1999.9kΩ	1V	1μA
20MΩ	19.999MΩ	1V	100nA
			<b>Accuracy</b>
			± (.08% of reading + 2 digits)
			± (.08% of reading + 2 digits)
			± (.03% of reading + 1 digit)
			± (.03% of reading + 1 digit)
			± (.03% of reading + 1 digit)
			± (.04% of reading + 1 digit)
			± (.15% of reading + 1 digit)
<b>Ranging:</b> Automatic or Manual.			
<b>Input Configuration:</b> 2 wire with lead zero (700mΩ adjustment range on the 20Ω and 200 ranges only).			
<b>Response Time:</b> <1.1 seconds to within 1 digit of final value on one range. Add 0.8 seconds for each range change.			
<b>DIODE TEST</b>			
<b>Function:</b>  (kΩ).			
<b>Range:</b>  (2kΩ).			
<b>Test Current:</b> 1mA ± 1.5%.			
<b>Maximum Measureable Voltage Drop:</b> 1.9999 volts.			
<b>Overload Protection:</b> 350V (dc 2 peak ac).			

Table 1-2. General Information

<b>GENERAL</b>	<b>Power:</b> AC line; 48 – 440Hz	86 – 106V Opt. 100 104 – 127V Opt. 115 190 – 233V Opt. 210 208 – 250V Opt. 230
<b>Display:</b> 7 segment RED 0.3 inch high LED's. Function and range annunciation.	<b>Battery:</b> 5 hours minimum continuous operation. Recharge Time: 16 hours operating 12 hours non-operating. 1.5 hour, recharge provides 3 hours of continuous use.	
<b>Reading Rate:</b> 2.4 - 4.7/sec. depending on input level.	<b>Maximum Power Dissipation:</b> 9 watts – with battery charger. 4 watts – AC only.	
<b>A-D conversion:</b> Dual slope.	<b>Configuration:</b> 3466A Std, Streamlined portable case with handle, ac line power. Rechargeable batteries, and recharger included.	
<b>Integration Time:</b> 100 msec.	3466A Option 001, Streamlined portable case, as ac line power only.	
<b>Ranging:</b> Automatic or manual in acV, dcV, acV + dcV and Ohms. Manual only in acI, dcI and acI + dcI.	<b>Dimensions:</b> 3466A: 23.81 cm (9 3/8") wide x 9.84 cm (3 7/8") high x 27.62 cm (10 7/8") long.	
<b>Storage Temperature:</b> (-55 to +75)°C; (-55 to 65)°C with batteries.	<b>Weight:</b> 3466A: 2.77 kg (6 lbs 2 oz.) 3466A Option 001: 1.98 kg (4 lbs 6 oz.)	
<b>Operating Temperature:</b> (0 to 55)°C.		
<b>Humidity:</b> 0 – 95% RH at 40°C.		

**Table 1-3. Options**

Standard	Streamlined portable case with handle. AC line or rechargeable battery operation with battery charger included.
Option 001	Streamlined portable case with handle. AC line operation only.
Option 002	Rack Mount case AC line operation only.
Option 100	86-106Vac 48-440Hz 9 Watts (Standard)
Option 115	104-127Vac 48-440Hz 9 Watts (Standard)
Option 210	190-233Vac 48-440Hz 9 Watts (Standard)
Option 230	208-250Vac 48-440Hz 9 Watts (Standard)
Option 910	An additional Operating and Service Manual.

**Table 1-4. Accessories**

11002A	Test leads (dual banana to dual alligator).
11003A	Test leads dual banana to probe and alligator.
11096B	RF Probe 10kHz to 700MHz, use only 10V and 100V dc ranges.
34110A	Soft vinyl carrying/operating case.
34111A	High voltage probe, 40kV dc.
34112A	Touch - Hold, input probe.
11067A	Test lead kit.





<p>250 V OPERATION</p>  <p>PLUG*: CEE7-V11 CABLE*: HP B120-1892</p>	<p>250 V OPERATION</p>  <p>PLUG*: CEE22-V1 CABLE*: HP B120-1880</p>	<p>250 V OPERATION</p>  <p>PLUG*: DHCR 107 CABLE*: HP B120-2956</p>	<p>250 V OPERATION</p>  <p>PLUG*: SEV 1011.1859-24507 TYPE 12 CABLE*: HP B120-2104</p>	
<p>125 V - 6A**</p>  <p>PLUG*: NEMA 1-15P CABLE*: HP B120-0884</p>	<p>250 V OPERATION</p>  <p>PLUG*: NZSS 19B/AS C112 CABLE*: HP B120-0696</p>	<p>250 V OPERATION</p>  <p>PLUG*: BS 1363A CABLE*: HP B120-1703</p>	<p>250 V - 6A**</p>  <p>PLUG*: NEMA G-15P CABLE*: HP B120-0698</p>	<p>125 V - 6A**</p>  <p>PLUG*: NEMA 5-15P CABLE*: HP B120-1521</p>
<p>STD-B-4195 (Rev.)</p> <p>*The number shown for the plug is the industry identifier for the plug only. The number shown for the cable is an HP part number for a complete cable including the plug. ** UL listed for use in the United States of America</p>				

Figure 2-1. Power Receptacles

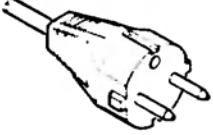
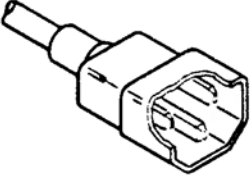
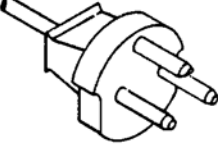
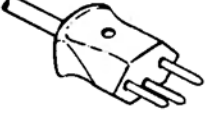
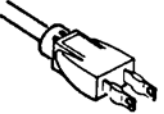

# SECTION II

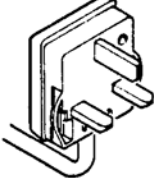
## INSTALLATION

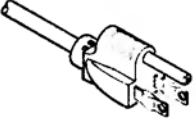
### 2-1. INTRODUCTION

2-2. This section contains information and instructions for the installation and shipping of the Multimeter. Included are initial inspection procedures, power and grounding requirements, environmental information, and instructions for repackaging the instrument for shipment.

### 2-3. INITIAL INSPECTION

2-4. This instrument was carefully inspected both mechanically and electrically before shipment. It should be free of marks or scratches and in perfect electrical order upon receipt. To confirm this, the instrument should be inspected for physical damage. Electrical performance should be tested using the performance test outlined in Section IV. If there is damage or deficiency, see the warranty inside the front cover of this manual.

### 2-5. POWER REQUIREMENTS

2-6. The Multimeter can be operated from any one of the ac power sources listed in Table 1-2. Before connecting the instrument to ac power, verify that the ac power source matches the power requirement of the instrument as marked on the option label affixed to the rear of the instrument. If the instrument is incompatible with the available power source, refer to Section V for Power Requirement Modification instructions.

### 2-7. ENVIRONMENTAL REQUIREMENTS

2-8. To meet and maintain the specifications listed in Table 1-1, the Multimeter must be operated within an ambient temperature range of +18°C to +28°C (64°F to 82°F). The instrument may be operated within an ambient temperature range of 0°C to +55°C (32°F to 131°F) with less accuracy.

### WARNING

*To help minimize the possibility of electrical fire or shock hazards, do not expose this instrument to rain or excess moisture.*

### 2-9. REPACKAGING FOR SHIPMENT

2-10. The following paragraphs contain a general guide

for repackaging the instrument for shipment. Refer to Paragraph 2-11 if the original container is to be used; 2-12 if it is not. If you have any questions, contact your nearest -hp- Sales and Service Office (See Appendix A for office locations).

### NOTE

*If the instrument is to be shipped to Hewlett-Packard for service or repair, attach a tag to the instrument identifying the owner and indicating the service or repair to be accomplished. Include the model number and full serial number of the instrument. In any correspondence, identify the instrument by model number and full serial number.*

2-11. Place instrument in original container with appropriate packing material and seal well with strong tape or metal bands. If original container is not available, one can be purchased from your nearest -hp- Sales and Service Office.

2-12. If original container is not to be used, proceed as follows:

a. Wrap instrument in heavy paper or plastic before placing in an inner container.

b. Place packing material around all sides of instrument and protect front panel with cardboard strips.

c. Place instrument and inner container in a heavy carton or wooden box and seal with strong tape or metal bands.

### 2-13. POWER CORDS AND RECEPTACLES

2-14. Figure 2-1 illustrates the plug cap configurations that are available to provide ac power to the Multimeter. The -hp- part number shown directly below each plug cap drawing is the part number for the power cord set equipped with the appropriate mating plug for that receptacle. The appropriate power cord should be provided with each instrument. However, if a different power cord set is required, notify the nearest -hp- Sales and Service Office and a replacement cord will be provided. The instrument ac power input receptacle and cord set appliance coupler meet the safety specifications set by the International Commission on Rules for the Approval of Electrical Equipment (CEE 22).

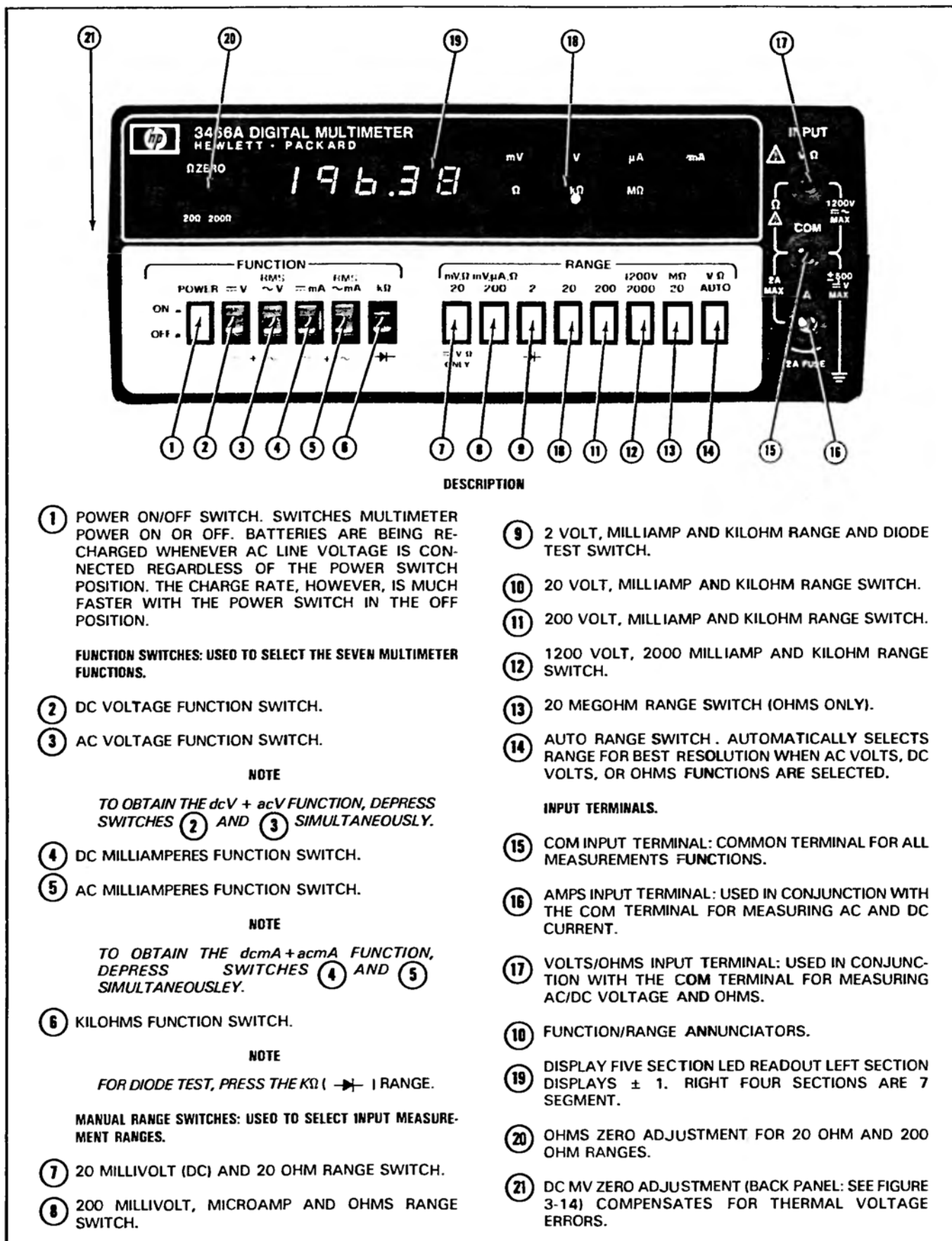

DESCRIPTION

① POWER ON/OFF SWITCH. SWITCHES MULTIMETER POWER ON OR OFF. BATTERIES ARE BEING RECHARGED WHENEVER AC LINE VOLTAGE IS CONNECTED REGARDLESS OF THE POWER SWITCH POSITION. THE CHARGE RATE, HOWEVER, IS MUCH FASTER WITH THE POWER SWITCH IN THE OFF POSITION.

**FUNCTION SWITCHES: USED TO SELECT THE SEVEN MULTIMETER FUNCTIONS.**

- ② DC VOLTAGE FUNCTION SWITCH.
- ③ AC VOLTAGE FUNCTION SWITCH.

NOTE

TO OBTAIN THE *dcV + acV* FUNCTION, DEPRESS SWITCHES ② AND ③ SIMULTANEOUSLY.

- ④ DC MILLIAMPERES FUNCTION SWITCH.
- ⑤ AC MILLIAMPERES FUNCTION SWITCH.

NOTE

TO OBTAIN THE *dcmA + acmA* FUNCTION, DEPRESS SWITCHES ④ AND ⑤ SIMULTANEOUSLY.

- ⑥ KILOHMS FUNCTION SWITCH.

NOTE

FOR DIODE TEST, PRESS THE  $k\Omega$  (  $\rightarrow$  ) RANGE.

**MANUAL RANGE SWITCHES: USED TO SELECT INPUT MEASUREMENT RANGES.**

- ⑦ 20 MILLIVOLT (DC) AND 20 OHM RANGE SWITCH.
- ⑧ 200 MILLIVOLT, MICROAMP AND OHMS RANGE SWITCH.

- ⑨ 2 VOLT, MILLIAMP AND KILOHM RANGE AND DIODE TEST SWITCH.
- ⑩ 20 VOLT, MILLIAMP AND KILOHM RANGE SWITCH.
- ⑪ 200 VOLT, MILLIAMP AND KILOHM RANGE SWITCH.
- ⑫ 1200 VOLT, 2000 MILLIAMP AND KILOHM RANGE SWITCH.
- ⑬ 20 MEGOHM RANGE SWITCH (OHMS ONLY).
- ⑭ AUTO RANGE SWITCH. AUTOMATICALLY SELECTS RANGE FOR BEST RESOLUTION WHEN AC VOLTS, DC VOLTS, OR OHMS FUNCTIONS ARE SELECTED.

INPUT TERMINALS.

- ⑮ COM INPUT TERMINAL: COMMON TERMINAL FOR ALL MEASUREMENTS FUNCTIONS.
- ⑯ AMPS INPUT TERMINAL: USED IN CONJUNCTION WITH THE COM TERMINAL FOR MEASURING AC AND DC CURRENT.
- ⑰ VOLTS/OHMS INPUT TERMINAL: USED IN CONJUNCTION WITH THE COM TERMINAL FOR MEASURING AC/DC VOLTAGE AND OHMS.

- ⑱ FUNCTION/RANGE ANNUNCIATORS.
- ⑲ DISPLAY FIVE SECTION LED READOUT LEFT SECTION DISPLAYS  $\pm 1$ . RIGHT FOUR SECTIONS ARE 7 SEGMENT.
- ⑳ OHMS ZERO ADJUSTMENT FOR 20 OHM AND 200 OHM RANGES.
- ㉑ DC MV ZERO ADJUSTMENT (BACK PANEL: SEE FIGURE 3-14) COMPENSATES FOR THERMAL VOLTAGE ERRORS.

Figure 3-1. Description of Controls and Connectors

# SECTION III

## OPERATING INSTRUCTIONS

### 3-1. INTRODUCTION

3-2. This section contains instructions for operating the Multimeter. Measurements of ac and dc voltage, ac and dc current, and ohms are discussed. A description of the controls and connectors is given in Figure 3-1.

**WARNING**

*To prevent potential electrical or fire hazard, do not expose the Multimeter or its accessories to rain or moisture.*

### 3-3. AC Operation

3-4. Before connecting the Multimeter to ac power, verify that the ac power source matches the power requirements of the Multimeter as marked in the option label affixed to the rear of the instrument. If the instrument is incompatible with the available power source, refer to Section V of this manual for power requirement modification instructions. After this verification, connect the proper ac power to the instrument and press the ON button. The instrument is ready for use.

### 3-5. Battery Operation

3-6. **Recharging the Battery.** Before operating the Multimeter in the Battery Mode, ensure that the battery is charged. Connect the Multimeter to the proper ac line voltage and allow 12 hours for a full recharge with the POWER switch off (out). This provides a minimum operating time of 8 hours. A 1.5 hour recharge (instrument off) will allow an operating time of 3 hours. Operating the instrument with the proper ac line voltage connected and POWER switch on, provides a full battery recharge in 16 hours.

#### NOTE

*Repeated partial charge cycles may result in a temporary loss of battery capacity. Normal capacity can be restored by fully charging the battery.*

3-7. **Low Battery Voltage.** The Multimeter will operate in Battery Mode when the battery voltage is greater than 5.6V. This voltage is measured through the access hole on the bottom of the Multimeter. To accomplish this, perform the following procedure:

- a. Disconnect ac line voltage.
- b. Select dcV function and 20V range.
- c. Insert the V -  $\Omega$  test probe into the access hole as shown in Figure 3-2.

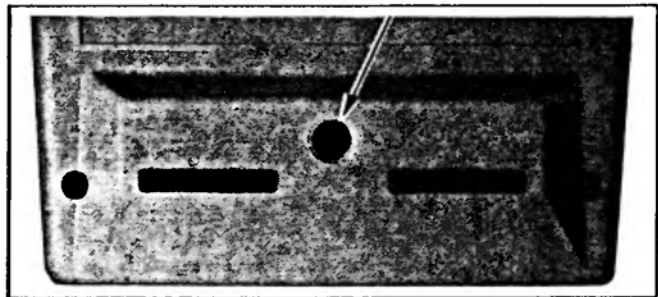

Figure 3-2. Battery Voltage Access Hole

3-8. If the battery voltage drops below 5.6 volts, the Multimeter will automatically stop operating (blank display) to prevent damage to the battery. If this occurs, recharge the battery.

3-9. If the display has blanked due to low battery voltage, and there is a requirement to make one or two more measurements before recharging the battery, set the POWER switch to OFF for approximately 15 minutes and the make the measurement. This allows the battery to partially rejuvenate.

### 3-10. Overload/Overrange/Improper Function Indication

3-11. Figure 3-3 shows the display indication during overload, overrange, or an improper switch setting.



Figure 3-3. Overload Indication

3-12. Table 3-1 lists improper switch combinations.

Table 3-1. Improper Switch Combinations

Function	Range		
--- V		MΩ 20	
~V	mV,Ω 20	MΩ 20	
--- V + ~V	mV,Ω 20	MΩ 20	
--- mA	mV,Ω 20	MΩ 20	Auto
~mA	mV,Ω 20	MΩ 20	Auto
--- mA + ~mA	mV,Ω 20	MΩ 20	Auto

3-13. Auto

3-14. Depressing the AUTO switch with acV, dcV, acV + dcV or kΩ function selected sets the Multimeter in an automatic ranging mode. In this mode the Multimeter will *uprange* if the display reading increases above (+) or (-) 

1	9	9	9	9
---	---	---	---	---

 and *downrange* if the display decreases below (+) or (-) 

1	8	0	0
---	---	---	---

. These numerical autoranging points are irrespective of decimal placement. The difference between the two autoranging points is called *autoranging hysteresis*. Figure 3-4 shows the autoranging points of ac voltage measurement from 0 to 1200 Vac. Autoranging in other Multimeter functions is similar.

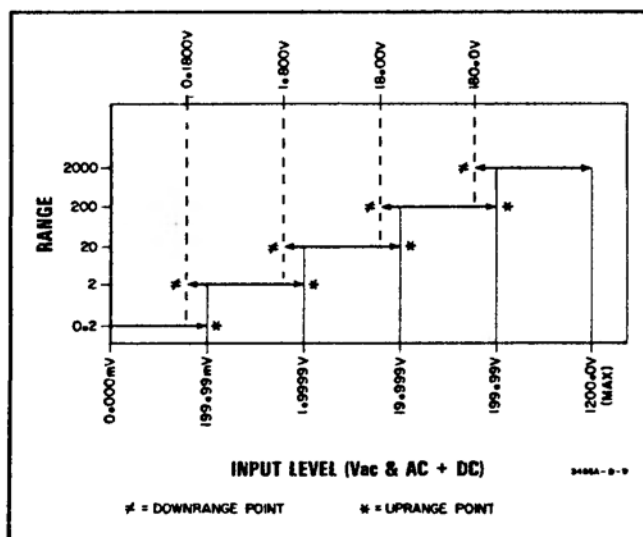

Figure 3-4. Multimeter Autoranging

3-15. To release the AUTO switch depress one of the MANUAL RANGE switches.

3-16. Input Terminals

3-17. VΩ (Volts/Ohms). The VΩ terminal is the *high* terminal for ac and dc voltage measurement. For ohms measurements, it is the positive (+) terminal.

3-18. COM (Common). The COM terminal is used for all five Multimeter functions. It is the negative (-) terminal for ohms measurements and it is the *low* terminal for ac and dc voltage and current measurements.



To avoid possible damage to the Multimeter circuitry, the voltage between COM and (earth ground) must not exceed ± 500 Vdc.

3-19. A (Amps). The A terminal is the *high* terminal for ac and dc amps measurements. There is a 2 amp input protection fuse in series with this terminal.



The current function is protected by a fuse of 250 V rating. To avoid damage to the Multimeter, current sources having open circuit voltages greater than 250 V (dc + peak ac) must not be connected to the A (amps) input terminal.

3-20. DC Voltage Measurements



To avoid possible damage to the Multimeter circuitry, the dc input voltage must not exceed 1200 V (dc + peak ac).

3-21. Procedure

- a. Depress --- V (dc Volts).
- b. Depress proper manual range (200 mV to 1200 V) or depress AUTO for automatic range selection.

NOTE

Thermal voltages from test lead connections and measurement circuits are cancelled by setting the Multimeter to the 20 mV range, shorting the test leads together and adjusting the --- mV Zero (back panel) for a Multimeter reading of 0.000 mV.

- c. Connect test leads from the Multimeter VΩ (high) and COM (low) terminals to the voltage under test as shown in Figure 3-5.

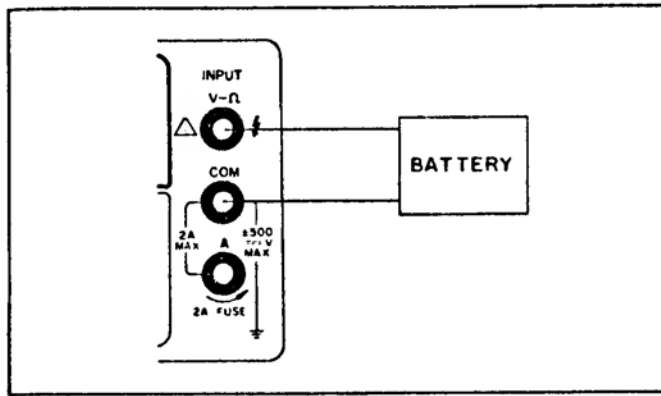

Figure 3-5. DC Voltage Measurements

3-22. AC Voltage Measurements



To avoid possible damage to the Multimeter circuitry, the ac input voltage must not exceed 600 Vdc or 1700 V (dc + peak ac).

3-23. Procedure

- a. Depress ~ V (ac volts).
- b. Depress proper manual range (200 mV to 1200 V) or depress AUTO for automatic range selection.
- c. Connect test leads from the Multimeter VΩ (high) and COM (low) terminals to the voltage under test as shown in Figure 3-6.

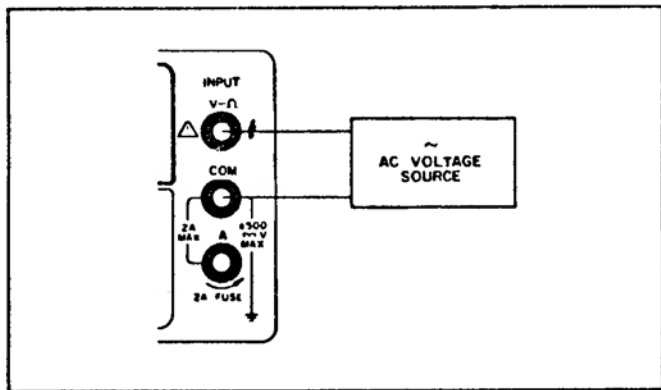

Figure 3-6. AC Voltage Measurement

d. The value displayed with a shorted input represents the true rms value of internal circuit noise in the multimeter. An offset of 100 counts will not, however, introduce a 10% error into a 1000 count reading. Using the definition of rms, the displayed reading would be the square root of the sum of the squares:

$$rms = \sqrt{(1000)^2 + (100)^2} = 1005$$

The error introduced is 5/1000 which is 0.5%.

e. The accuracy specification are not valid for inputs of less than 1900 digits (less than 9.5% of full scale).

3-24. True RMS (dc + ac) Voltage Measurements



To avoid possible damage to the multimeter circuitry, the input voltage must not exceed 1200 Vdc or 1700 V (dc + peak ac).

3-25. Procedure

- a. Depress --- V and ~ V simultaneously.
- b. Depress the proper manual range (200 mV to 1200 V) or auto for automatic range selection.
- c. Connect test leads from the multimeter VΩ (high) and COM (low) terminal to the Voltage under test as shown in Figure 3-7.

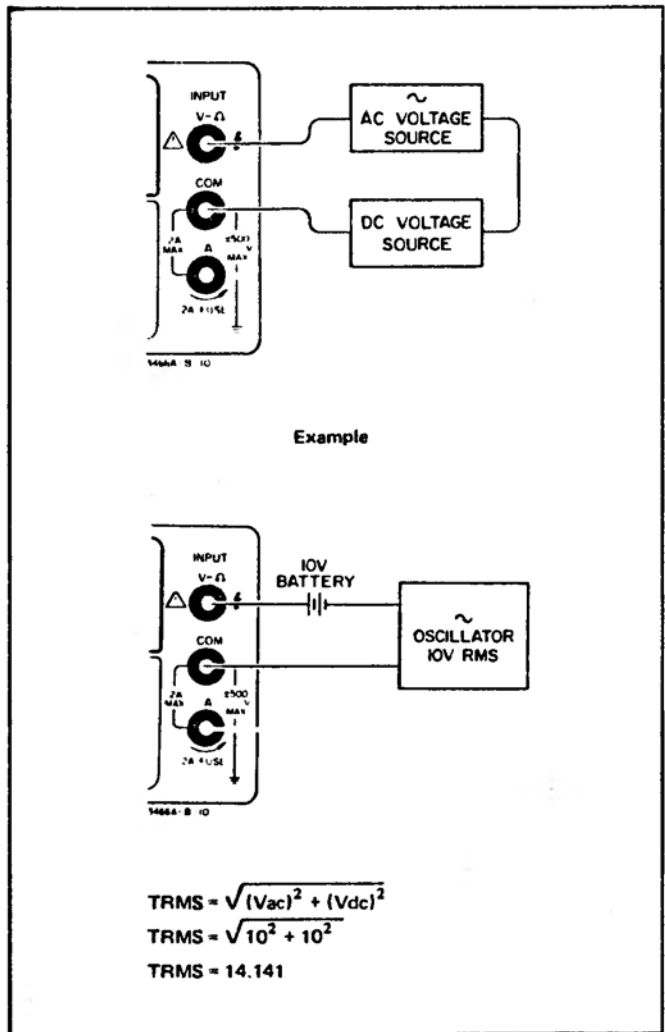

Figure 3-7. True RMS (dc + ac) Voltage Measurements

3-26. DC Current Measurement



The current function is protected by a fuse of 250 V rating. To avoid damage to the Multimeter, current sources having open circuit voltages greater than 250 V (dc + peak ac) must not be connected to the A (amps) input terminal.

**3-27. Procedure**

- a. Depress  $\overline{\text{---}}$  mA (dc milliamperes).
- b. Depress proper manual range (200  $\mu$ A to 2000 mA).
- c. Connect test leads from the Multimeter A and COM terminals in series with the current under test as shown in Figure 3-8.

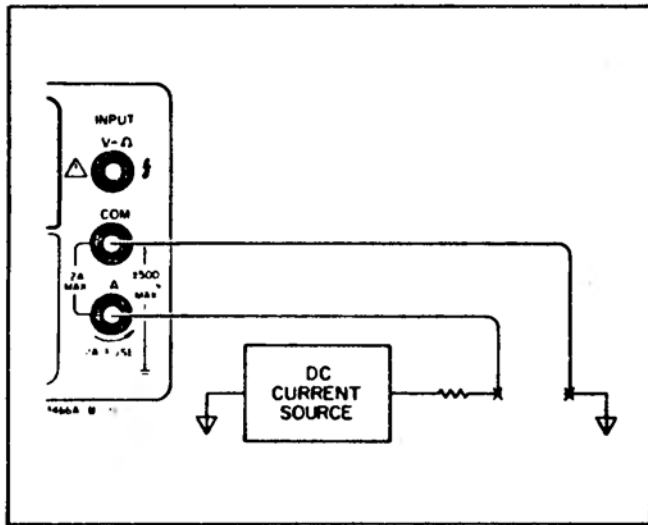

Figure 3-8. DC Current Measurements

**3-28. AC Current Measurements**



The current function is protected by a fuse of 250 V rating. To avoid damage to the Multimeter, current sources having open circuit voltages greater than 250 V (dc + peak ac) must not be connected to the A (amps) input terminal.

**3-29. Procedure**

- a. Depress  $\sim$  mA (ac milliamperes).
- b. Depress proper manual range (200  $\mu$ A to 2000 mA).
- c. Connect test leads from the Multimeter A and COM terminals in series with the current under test as shown in Figure 3-9.

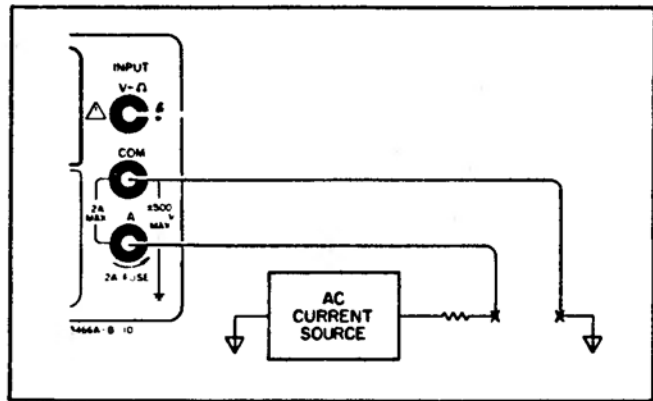

Figure 3-9. AC Current Measurement

**3-30. True RMS (dc + ac) Current Measurements**

**3-31. Procedure**

- a. Depress  $\overline{\text{---}}$  mA and  $\sim$  mA simultaneously.
- b. Depress proper manual range (200 mA to 2000 mA).
- c. Connect test leads from the Multimeter A and COM terminals in series with the current under test as shown in Figure 3-10.

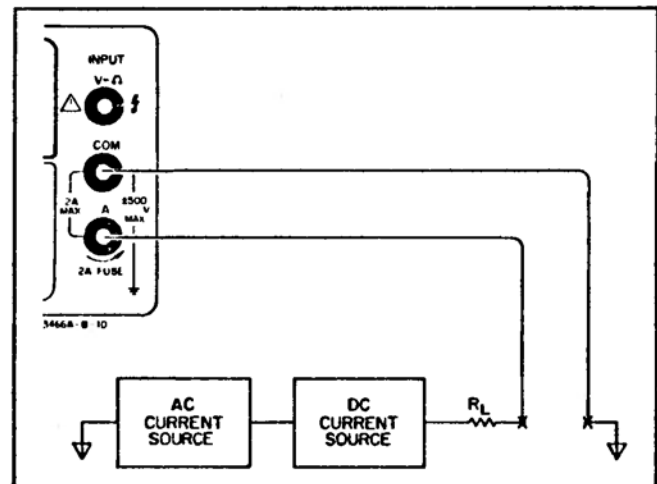

Figure 3-10. True RMS Current Measurement

**3-32. Resistance Measurements**

**3-33. Ohms Zero.** When making resistance measurements using the 200 ohm and 20 ohm ranges, the resistance of the test leads being used is nullified by using the following procedure:

- a. Short the test leads together.
- b. Depress the 20  $\Omega$  range.
- c. Adjust the ohms zero potentiometer (see Figure 3-14 for the potentiometer location) for a 0.000 reading on the display.

**NOTE**

*Ohms zero is disabled in the 2K thru 20M ranges.*

**3-34. Procedure**

- a. Depress  $k\Omega$  (kilohms).
- b. Depress proper manual range (20  $\Omega$  to 20 M $\Omega$ ).
- c. Connect test leads from the Multimeter  $V\Omega$  (+) and COM (-) terminals to the resistance under test as shown in Figure 3-11.

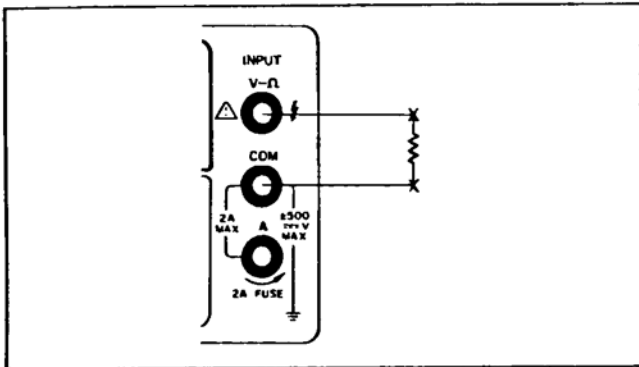

**Figure 3-11. Resistance Measurement**

**3-35. Diode Test**

3-36. Diode and transistor junction voltage can be measured using the following procedure:

- a. Depress the  $\rightarrow|$  ( $k\Omega$ ) function.
- b. Depress  $\rightarrow|$  (2  $k\Omega$ ) range.
- c. Connect test leads across the diode or transistor as shown in Figure 3-12.

**NOTE**

*By selecting the  $k\Omega$  function and the 2  $k\Omega$  range, a 1 mA current source is provided.*

*The display is read directly in volts even though the  $k\Omega$  annunciator will be lit.*

*The  $V\Omega$  terminal is the positive (+) lead.*

- d. The display reading will represent the forward voltage drop, measured in volts across the junctions (approximately 0.6 V for silicon and 0.3 V for germanium).

**NOTE**

*Multiple PN junctions can be measured in series if the cumulative voltage drop does not exceed 1.9999 volts.*

- e. If the leads are reversed, an "OL" reading will typically be displayed.

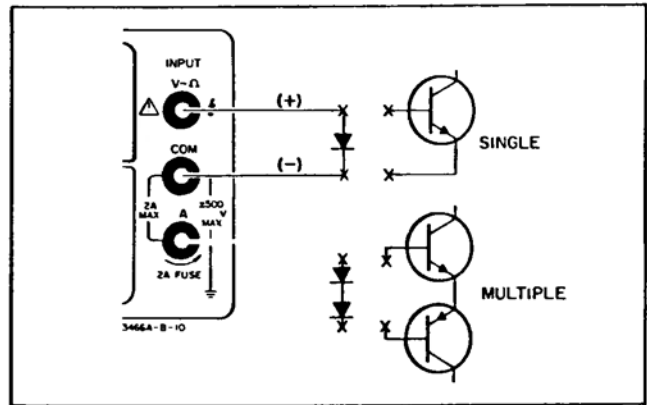

**Figure 3-12. Diode Test**

**3-37. Handle/Bail**

3-38. The Multimeter display viewing angle is adjusted by rotating the Handle/Bail to a convenient position as shown in Figure 3-13.

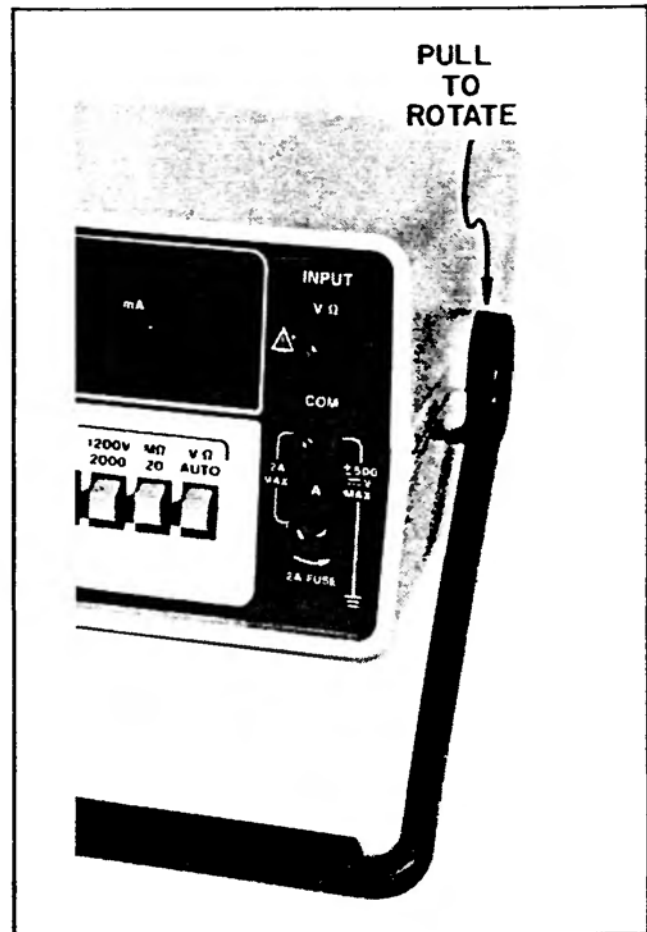

**Figure 3-13. Handle/Bail Positioning**

**3-39. Option Decal**

3-40. The option decal is affixed to the rear of the Multimeter. An example is shown in Figure 3-14.

**3-41. Information Decal**

3-42. The information decal shown in Figure 3-15 is affixed to the underside of the Multimeter.

**3-43. Amps Input Fuse Replacement**

3-44. The amps input is protected by a 2A 250 V fuse, -hp- Part Number 2110-0002. This fuse is easily replaced using the following procedure:

- a. Insert a coin or wide bladed screwdriver into the slots of the A input terminal.
- b. Press the color ring in and rotate it counterclockwise 1/3 turn.

c. Remove and replace the blown fuse.

**3-45. Multimeter Cleaning**



*Do not allow cleaning solvents, flux remover, or alcohol to come in contact with the Multimeter.*

3-46. The Multimeter case and front panel should only be cleaned with a mild solution of soap and water and a soft cloth.

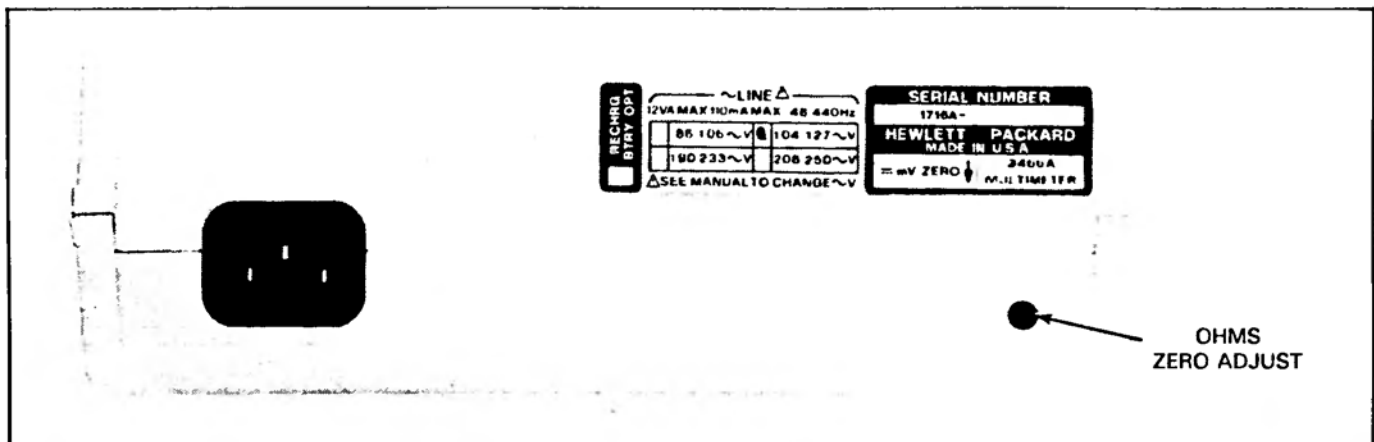

Figure 3-14. Option Decal and Ohms Zero Adjust

**3466ADIGITAL MULTIMETER**  
HEWLETT-PACKARD

**WARNING:** NO OPERATOR SERVICEABLE PARTS INSIDE REFER SERVICING TO TRAINED SERVICE PERSONNEL

---

**Ω (OHMS)**

•  $V \leq 5V$  OPEN CIRCUIT  
• PROTECTION:  $\pm 350V$  OR 250VRMS  
•  $\Omega$  ZERO (20 $\Omega$  AND 200 $\Omega$  RANGES ONLY): LEAD RESISTANCE MAY BE NULLED WITH FRONT PANEL  $\Omega$  ZERO MAX NULL -700m $\Omega$

RANGE	I	V@10k CNTS
20 $\Omega$	5mA	50mV
200 $\Omega$	5mA	500mV
2k $\Omega$	1mA	1V
20k $\Omega$	100 $\mu$ A	1V
200k $\Omega$	10 $\mu$ A	1V
2M $\Omega$	1 $\mu$ A	1V
20M $\Omega$	100 $\mu$ A	1V

**(DIODE TEST)**

• FUNCTION k $\Omega$   
• RANGE 2k $\Omega$  - 1M $\Omega$   
• I - 1mA  
• DIODE VOLTAGE DROP DISPLAYED IN VOLTS

---

**TRUE RMS VOLTS**

•  $\sim V$  MAX INPUT: 600V OR 1700V(= +Pk $\sim$ )  
10<sup>7</sup> V $\cdot$ Hz  
FREQ RANGE: 30Hz - 100kHz  
•  $\sim V + \sim V$  MAX INPUT: 1200V OR 1700V(= +Pk $\sim$ )  
10<sup>7</sup> V $\cdot$ Hz  
FREQ RANGE: DC + (30Hz - 100kHz)  
DEPRESS  $\sim V$  AND  $\sim V$  SIMULTANEOUSLY

**= V (DC VOLTS)**

MAXIMUM INPUT  
1200.0V

---

**I (CURRENT) (MANUAL RANGE ONLY)**

MAX INPUT: 1.9999A (< 250V SOURCE)

RANGE	R
200 $\mu$ A	1k $\Omega$
2mA	100 $\Omega$
20mA	10 $\Omega$
200mA	1 $\Omega$
2000mA	0.1 $\Omega$

DEPRESS  $\sim V$  AND  $\sim I$  SIMULTANEOUSLY

**BATTERY**

CHARGE TIME	RUN TIME
PWR ON	AT 25 C
2.5 HR	1.5 HR
16 HR	12 HR
	3HR
	8HR

CONTINUOUS CHARGE WILL NOT HARM BATTERY  
5.6-6.4V BAT. TEST BETWEEN RUBBER FEET

---

**FUSES**

FUNCTION	VALUE	LOCATION
$\sim$ LINE	125mA/250V	MAIN BOARD
CURRENT	2A/250V	A INPUT
BATTERY	2A/250V	BAT. BOARD

**AUTO RANGE**

UP RANGE  
20000 COUNTS

DOWN RANGE  
1799 COUNTS

**SAMPLE RATE**

5/SEC AT 0000

2/SEC AT 19999

**'OL' DISPLAY**

OFF SCALE INPUT OR IMPROPER SELECTION OF FUNCTION AND RANGE

---

NOTE: SHORTING COM TO A STOPS SAMPLING IN  $\sim V$ ,  $\sim V$ , AND  $\sim V + \sim V$  FUNCTIONS

Figure 3-15. Information Decal



# SECTION IV

## PERFORMANCE TESTS

### 4-1. INTRODUCTION

4-2. This section of the manual has the 3466A's Performance Tests which are used to verify the specifications listed in Table 1-1 (in Section I). Some of the Performance Tests include two tests: a complete and abbreviated test. The complete test is used to verify the performance of the 3466A and the abbreviated test is used to verify a repair.

### 4-3. REQUIRED EQUIPMENT

4-4. The equipment required to do the Performance Tests is listed in Table 4-1. If any of the required equipment is not available, use substitute equipment that meets the critical requirements listed in the table.

### 4-5. TEST CARDS

4-6. The Performance Test Cards are at the end of this section to record the Performance Tests results. These cards may be used as a permanent record and may be reproduced without written permission from Hewlett-

Packard. Two sets of Test Cards are provided. One set is used to record the complete Performance Test and the other is used to record the Abbreviated Performance Test.

### 4-7. WARM-UP TIME

4-8. The 3466A must be warmed up for at least 15 minutes before doing any testing.

### 4-9. PERFORMANCE TESTS

4-10. The Performance Tests are separated as follows:

- DC Voltmeter Accuracy Test - paragraph 4-11
- AC Voltmeter Accuracy Test - paragraph 4-14
- True RMS Voltmeter Accuracy Test - paragraph 4-17
- DC Ammeter Accuracy Test - paragraph 4-20
- AC Ammeter Accuracy Test - paragraph 4-23
- True RMS Ammeter Accuracy Test - paragraph 4-26
- Ohmmeter Accuracy Test - paragraph 4-29
- AC Normal Mode Rejection Test - paragraph 4-32
- AC Common Mode Rejection Test - paragraph 4-36
- DC Common Mode Rejection Test - paragraph 4-40

**Table 4-1. Required Test Equipment**

Instrument Type	Required Characteristics	Recommended Model
DC Voltage Standard	Output: 1mV to 1000V Accuracy: $\pm 0.02\%$	Systron Donner Model M107
AC Calibrator/High Voltage Amplifier	Output: 10mV to 1000V Frequency: 20Hz to 100kHz Accuracy: $\pm 0.1\%$ (mid band)	Fluke Model 5200A/5215A
Digital Multimeter	Accuracy: $\pm .01\%$	-hp- Model 3468A
Meter Calibrator	Output: 1A Accuracy: $\pm 0.1\%$	-hp- Model 6920B
Electronic Counter	Frequency: 50Hz and 60Hz	-hp- Model 5381A
DC Power Supply	Output Voltage: 0 to 20V Output Current: 0 to 2A	-hp- Model 6294A
Resistor Decade Box	Resistors: 1 ohm to 1M ohms Accuracy: $\pm 0.005\%$	General Radio Model GR1433-H
Resistors*	1 ohm $\pm 0.02\%$ 10 ohm $\pm 0.01\%$ 1k ohms $\pm 0.01\%$ 10k ohms $\pm 0.01\%$ 100k ohms $\pm 0.01\%$ 1M ohms $\pm 0.01\%$ 10M ohms $\pm 0.1\%$ 22K ohms $\pm 1\%$	G.R. 1440-9601 G.R. 1440-9611 G.R. 1440-9631 G.R. 1440-9641 G.R. 1440-9651 G.R. 1440-9661 -hp- 0698-8194 -hp- 0757-1087
*G.R. = General Radio		

**4-11. DC Voltmeter Accuracy Test**



*To avoid possible damage to the Multimeter circuitry, the dc input voltage must not exceed 1200V (dc + peak ac).*

**4-12. Equipment Required.** The DC Standard (Systron Donner Model M107).

**4-13. Test Procedure.** The limits for the Abbreviated DC Voltmeter Accuracy Test are listed in Table 4-2 and the limits for the Complete DC Voltmeter Accuracy Test are listed in Table 4-3. Make sure the 3466A has been warmed up for at least 15 minutes. Do the following:

- a. Set the 3466A to the dc volts function and the 20mV range.
- b. Connect a short across the V and COM input terminals.
- c. Use a small flat blade screwdriver to adjust the 20mV ZERO ADJ on the rear panel (see Figure 3-14) for a 0.000mV reading on the display.
- d. Connect the DC Standard to the 3466A's input terminals as shown in Figure 4-1.
- e. Check the 3466A ranges as follows:
  1. Refer to Table 4-2 or Table 4-3. Make sure the 3466A is set to the 20mV range (first range listed in the "Range" column).
  2. Set the DC Standard output to the voltage level shown in the "DC Standard Output" column of the appropriate table.
  3. Check and make sure the 3466A is within the limits shown in the "Test Limits" columns of the table. Check the ranges that follow in the same manner.

**Table 4-2. Abbreviated DC Voltmeter Accuracy Test**

Range	DC Standard Output	Test Limits	
		High	Low
20mV	+ 19mV	+ 19.013mV	+ 18.988mV
200mV	- 190mV	- 190.10mV	- 189.90mV
2V	+ 1.9V	+ 1.9007V	+ 1.8993V
20V	+ 19V	+ 19.007V	+ 18.993V
20V	- 19V	- 19.007V	- 18.993V
200V	+ 190V	+ 190.07V	+ 189.93V
1200V	+ 1000V	+ 1000.7V	+ 999.4V

**Table 4-3. Complete DC Voltmeter Accuracy Test**

Range	DC Standard Output	Test Limits	
		High	Low
20mV	- 1mV	- 1.004mV	- 0.997mV
	- 5mV	- 5.006mV	- 4.995mV
	+ 10mV	+ 10.008mV	+ 9.992mV
	+ 19mV	+ 19.013mV	+ 18.988mV
200mV	+ 19mV	+ 19.03mV	+ 18.97mV
	+ 50mV	+ 50.04mV	+ 49.96mV
	- 100mV	- 100.06mV	- 99.94mV
	- 190mV	- 190.10mV	- 189.90mV
2V	- 190mV	- .1902V	- .1898V
	- 500mV	- .5003V	- .4998V
	+ 1.0V	+ 1.0004V	+ .9996V
	+ 1.9V	+ 1.9007V	+ 1.8993V
20V	+ 1.9V	+ 1.902V	+ 1.898V
	+ 5.0V	+ 5.003V	+ 4.998V
	- 10.0V	- 10.004V	- 9.996V
	- 19.0V	- 19.007V	- 18.993V
200V	+ 19.0V	+ 19.007V	+ 18.993V
	- 19.0V	- 19.02V	- 18.98V
	- 50.0V	- 50.03V	- 49.98V
	+ 100.0V	+ 100.04V	+ 99.96V
1200V	+ 190.0V	+ 190.07V	+ 189.93V
	- 190.0V	- 190.2V	- 189.8V
	+ 500.0V	+ 500.3V	+ 499.7V
	+ 1000.0V	+ 1000.7V	+ 999.4V

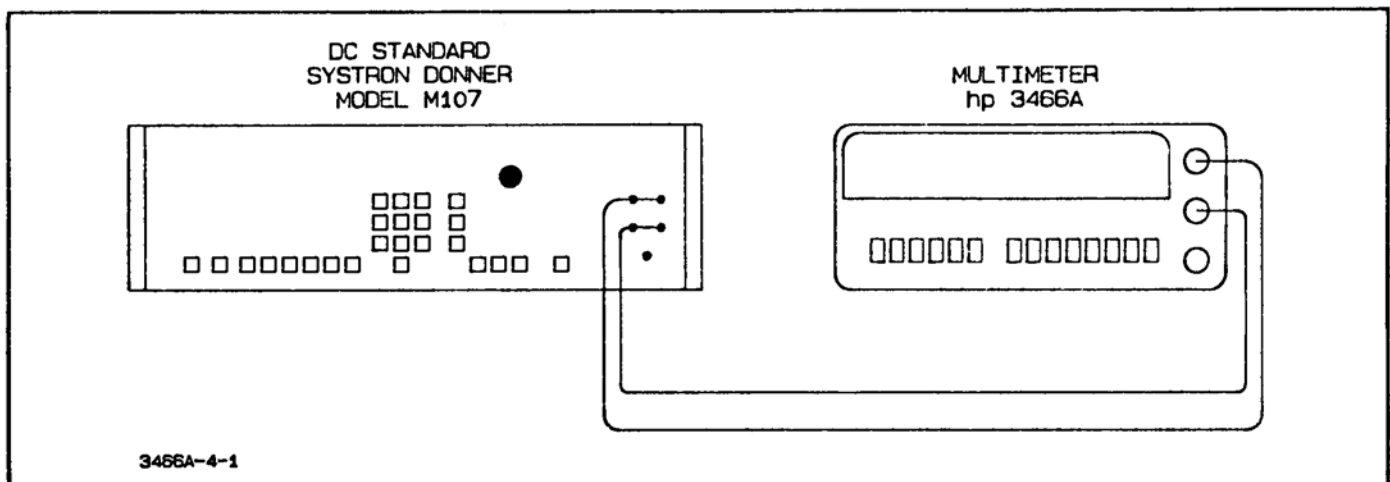

**Figure 4-1. DC Voltmeter Accuracy Test**

**4-14. AC Voltmeter Accuracy Test**



*To avoid possible damage to the Multimeter circuitry, the ac input voltage must not exceed 600V dc or 1700V (dc + peak ac).*

**4-15. Equipment Required.** The AC Calibrator and High Voltage Amplifier (Fluke Model 5200A/5215A).

**4-16. Test Procedure.** The limits for the Abbreviated AC Voltmeter Accuracy Test are listed in Table 4-4 and the limits for the Complete AC Voltmeter Accuracy Test are listed in Table 4-5. Make sure the 3466A has been warmed up for at least 15 minutes. Do the following:

- a. Set the 3466A to the ac volts function.
- b. Connect the AC Calibrator to the 3466A's input terminals as shown in Figure 4-2.
- c. Using the AC Calibrator, check the 3466A 200mV to 20V ranges and part of the 200V range as follows:
  1. Refer to Table 4-4 or Table 4-5. Make sure the 3466A is set to the 200mV range (first range listed in the "Range" column).
  2. Set the AC Calibrator output to the voltage level and frequency shown in the "AC Calibrator Output" and "Test Frequency" columns of the appropriate table.
  3. Check and make sure the 3466A is within the limits shown in the "Test Limits" columns of the table. Check the ranges that follow in the same manner.
- c. Using the AC Calibrator/High Voltage Amplifier combination, check the 3466A 200V to 1200V ranges as follows:
  1. Disconnect the AC Calibrator from the 3466A.
  2. Connect the High Voltage Amplifier to the 3466A.
  3. Set the AC Calibrator output to the voltage level and frequency shown in the "AC Calibrator Output" and "Test Frequency" columns of the appropriate table.
  4. Turn the High Voltage Amplifier on, and check and make sure the 3466A is within the limits shown in the "Test Limits" columns of the table. Check the ranges that follow in the same manner.
  5. When all ranges are tested, turn the High Voltage Amplifier off and disconnect it from the 3466A.

**Table 4-4. Abbreviated AC Voltmeter Accuracy Test**

Range	AC Calibrator Output	Test Frequency	Test Limits	
			High	Low
200mV	20mV	20Hz	20.90mV	19.10mV
2V	1.9V	100kHz	1.9530V	1.8470V
20V	2V	200Hz	2.026V	1.974V
20V	2V	10kHz	2.026V	1.974V
20V	19V	200Hz	19.077V	18.923V
20V	19V	10kHz	19.077V	18.923V
20V	19V	100kHz	19.530V	18.470V
200V	*190V	20Hz	194.30V	185.70V
1200V	*200V	10kHz	202.6V	197.4V

\*Use High Voltage Amplifier for these voltages

**Table 4-5. Complete AC Voltmeter Accuracy Test**

Range	AC Calibrator Output	Test Frequency	Test Limits	
			High	Low
200mV	20mV	20Hz	20.90mV	19.10mV
	20mV	20kHz	20.60mV	19.40mV
	20mV	50Hz	20.26mV	19.74mV
	50mV	100kHz	52.50mV	47.50mV
	50mV	10kHz	50.35mV	49.65mV
	50mV	30Hz	50.80mV	49.20mV
	100mV	20Hz	102.50mV	97.50mV
	100mV	20kHz	101.40mV	98.60mV
	100mV	50Hz	100.50mV	99.50mV
	.190V	30Hz	192.20mV	187.80mV
2V	.2V	30Hz	.2050V	.1950V
	1.9V	100kHz	1.9530V	1.8470V
	1V	20kHz	1.0050V	.9950V
20V	2V	20Hz	2.090V	1.910V
	2V	200Hz	2.026V	1.974V
	2V	30Hz	2.050V	1.950V
	2V	50Hz	2.026V	1.974V
	2V	10kHz	2.026V	1.974V
	5V	10kHz	5.035V	4.965V
	5V	20kHz	5.090V	4.910V
	19V	200Hz	19.077V	18.923V
	19V	10kHz	19.077V	18.923V
	19V	100kHz	19.530V	18.470V
200V	20V	10kHz	20.60V	19.40V
	100V	50Hz	100.50V	99.50V
	*190V	20Hz	194.50V	185.70V
1200V	*200V	10kHz	202.6V	197.4V
	*500V	30Hz	508.0V	492.0V
	*1000V	10kHz	1005.0V	995.0V

\*Use High Voltage Amplifier for these voltages



*Use extreme care when checking the ac volts ranges. Make sure all connections to the 3466A are correct before turning on the high voltage source. When the tests are completed, turn the high voltage off before disconnecting any cables or test leads.*

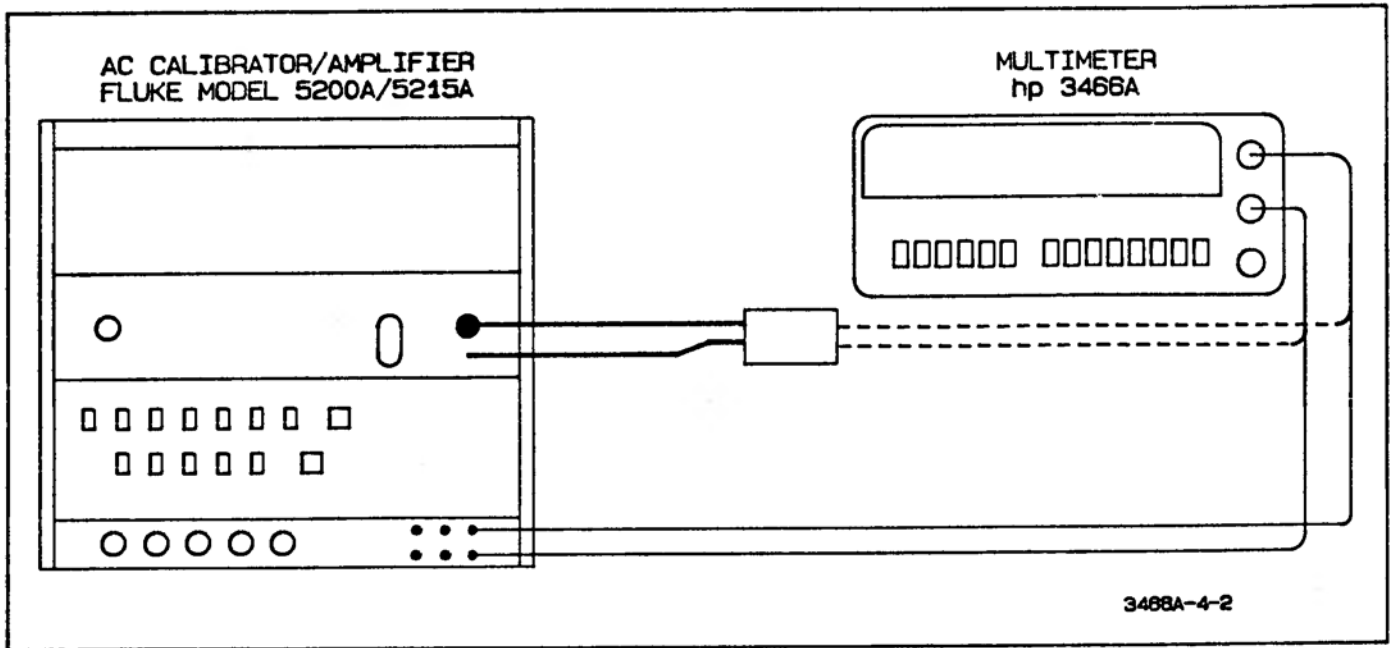

Figure 4-2. AC Voltmeter Accuracy Test

4-17. True RMS Voltmeter Accuracy Test



To avoid possible damage to the Multimeter circuitry, the ac input voltage must not exceed 600V dc or 1700V (dc + peak ac).

4-18. Equipment Required. The DC Standard (Systron Donner Model M107) and AC Calibrator (Fluke Model 5200A).

4-19. Test Procedure. The limits for the Abbreviated True RMS Voltmeter Accuracy Test are listed in Table 4-6 and the limits for the Complete True RMS Voltmeter Accuracy Test are listed in Table 4-7. Make sure the 3466A has been warmed up for at least 15 minutes. Do the following:

- a. Set the 3466A to the dc + ac volts function by simultaneously pressing the buttons for the dcV and acV functions.
- b. Disconnect the shorting bar (if so equipped) between the output low and ground terminals of the AC Calibrator.
- c. Connect the AC Calibrator and DC Standard to the 3466A as shown in Figure 4-3.
- d. Use the DC Standard and AC Calibrator to check the 3466A ranges as follows:
  1. Refer to Table 4-6 or Table 4-7. Make sure the 3466A is set to the 200mV range (first range listed in the "Range" column).

2. Set the DC Calibrator output to the voltage listed in the "DC Standard Output" column and set the AC Calibrator output to the voltage and frequency shown in the "AC Calibrator Output/Frequency" columns of the appropriate table.

3. Check and make sure the 3466A is within the limits shown in the "Test Limits" columns of the table. Check the ranges that follow in the same manner.

Table 4-6. Abbreviated True RMS Voltmeter Accuracy Test

Range	DC Standard Output	AC Calibrator		Test Limits	
		Output	Frequency	High	Low
200mV	20mV	20mV	20kHz	29.37mV	27.20mV
20V	20V	20V	20kHz	28.64V	27.92V
200V	20V	20V	100kHz	30.85V	25.72V

Table 4-7. Complete True RMS Voltmeter Accuracy Test

Range	DC Standard Output	AC Calibrator		Test Limits	
		Output	Frequency	High	Low
200mV	20mV	20mV	20Hz	29.37mV	27.20mV
	50mV	50mV	50Hz	72.21mV	69.20mV
	100mV	100mV	20kHz	143.63mV	139.20mV
2V	200mV	200mV	100kHz	.3085V	.2572V
	500mV	500mV	30Hz	.7221V	.6920V
	1V	1V	10kHz	1.4363V	1.3920V
20V	2V	2V	20Hz	2.937V	2.720V
	5V	5V	50Hz	7.221V	6.920V
	10V	10V	20kHz	14.363V	13.920V
200V	20V	20V	100kHz	30.85V	25.72V
	50V	50V	30Hz	72.21V	69.20V
	100V	100V	10kHz	143.63V	139.20V

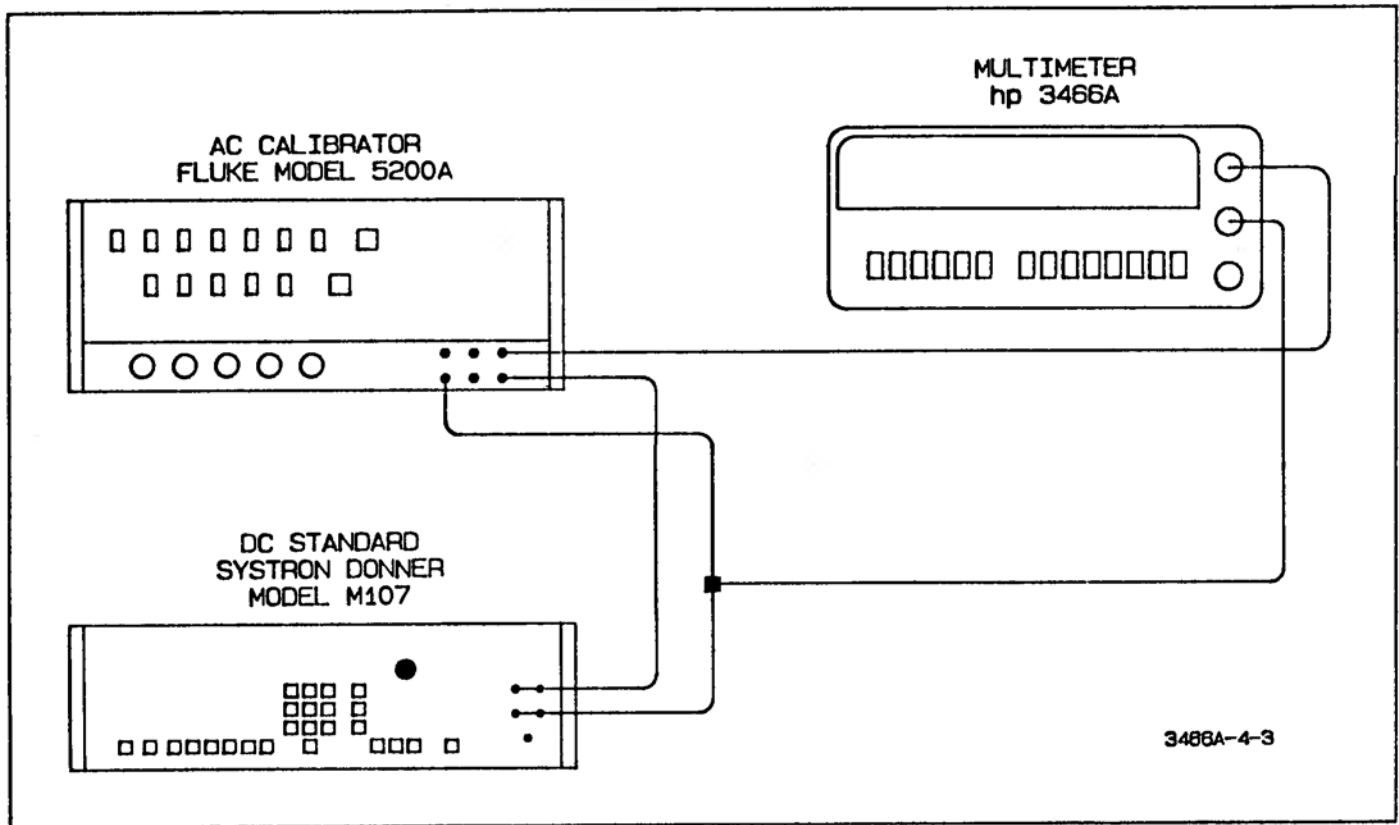

Figure 4-3. True RMS Voltmeter Accuracy Test

4-20. DC Ammeter Accuracy Test

4-21. Equipment Required. The following equipment is required to do the test.

- Digital Multimeter (-hp- Model 3468A)
- DC Power Supply (-hp- Model 6294A)
- Resistor 1 ohm  $\pm 0.02\%$   
(General Radio No. 1440-9601)
- Resistor 10 ohms  $\pm 0.01\%$   
(General Radio No. 1440-9611)
- Resistor 1k ohms  $\pm 0.01\%$   
(General Radio No. 1440-9631)
- Resistor 100k ohms  $\pm 0.01\%$   
(General Radio No. 1440-9651)

4-22. Test Procedure. The limits for the Abbreviated DC Ammeter Accuracy Test are listed in Table 4-8 and the limits for the Complete DC Ammeter Accuracy Test are listed in Table 4-9. Make sure the 3466A has been warmed up for at least 15 minutes. Do the following:

- a. Connect the 3466A to the power supply and Digital Multimeter as shown in Figure 4-4.
- b. Connect the 100k ohm  $\pm 0.01\%$  resistor in the Ra position as shown in Figure 4-4.
- c. Set the 3466A to the dcA function and the 200 $\mu$ A range.

Table 4-8. Abbreviated DC Ammeter Accuracy Test

Range	Current Level	Ra Value	Meter Reading	Test Limits	
				High	Low
200 $\mu$ A	100 $\mu$ A	100k, .01%	10.000V	100.09 $\mu$ A	99.91 $\mu$ A
2mA	1mA	1k, .01%	1.0000V	1.0009mA	.9991mA
20mA	10mA	1k, .01%	10.000V	10.009mA	9.991mA
200mA	100mA	10, .01%	1.0000V	100.17mA	99.83mA
2000mA	800mA	1, .02%	.80000V	804.2mA	795.8mA

Table 4-9. Complete DC Ammeter Accuracy Test

Range	Current Level	Ra Value	Meter Reading	Test Limits	
				High	Low
200 $\mu$ A	10 $\mu$ A	100k ohms $\pm 0.01\%$	1.0000V	10.03 $\mu$ A	9.97 $\mu$ A
	50 $\mu$ A		5.0000V	50.06 $\mu$ A	49.95 $\mu$ A
	100 $\mu$ A		10.000V	100.09 $\mu$ A	99.91 $\mu$ A
2mA	.1mA	1k ohms $\pm 0.01\%$	.10000V	.1003mA	.0997mA
	.5mA		.50000V	.5008mA	.4995mA
	1mA		1.0000V	1.0009mA	.9991mA
20mA	1mA	1k ohms $\pm 0.01\%$	1.0000V	1.003mA	.997mA
	5mA		5.0000V	5.006mA	4.995mA
	10mA		10.000V	10.009mA	9.991mA
200mA	10mA	10 ohms $\pm 0.01\%$	.10000V	10.04mA	9.997mA
	50mA		.50000V	50.10mA	49.91mA
	100mA		1.0000V	100.17mA	99.83mA
2000mA	100mA	1 ohm $\pm 0.02\%$	.10000V	100.7mA	99.3mA
	500mA		.50000V	502.7mA	497.3mA
	800mA		.80000V	804.2mA	795.8mA

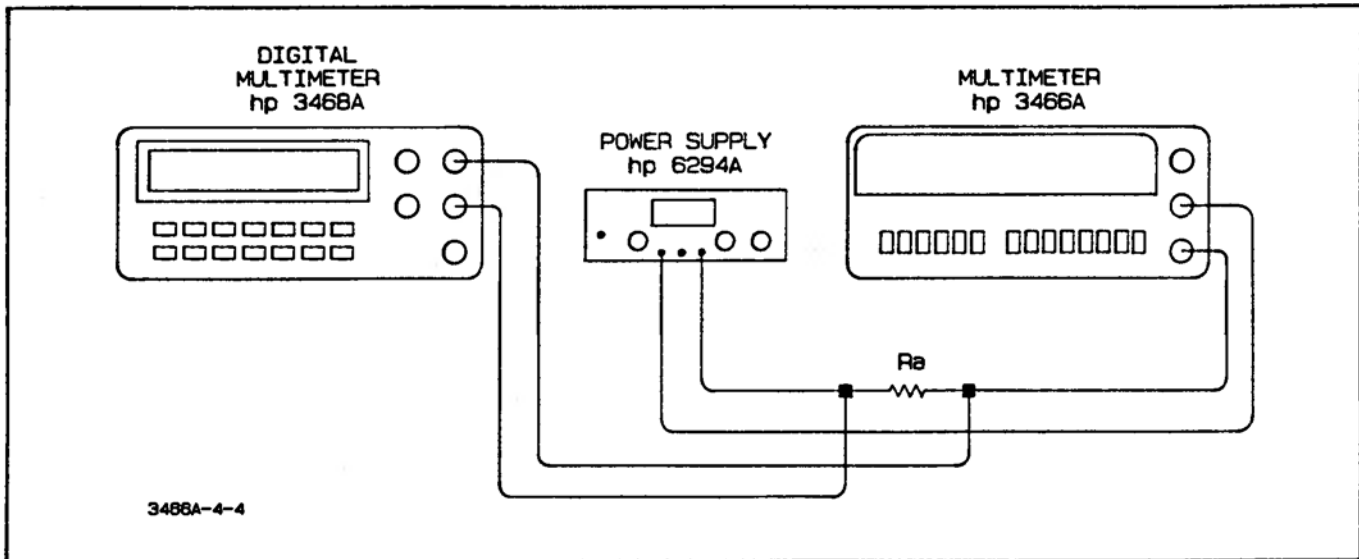

Figure 4-4. DC Ammeter Accuracy Test

d. Use the Digital Multimeter, DC Power Supply, and resistors  $R_a$  to check the 3466A ranges as follows:

1. Refer to Table 4-8 or Table 4-9. Make sure the 3466A is set to the  $200\mu\text{A}$  range (first range listed in the "Range" column).
2. Adjust the DC Power Supply until the reading on the Digital Multimeter is exactly as shown in the corresponding "Meter Reading" column of the table.
3. Check and make sure the 3466A is within the limits shown in the "Test Limits" columns of the table. Check the ranges that follow in the same manner. Make sure that the correct  $R_a$  resistor is selected for the other ranges, as shown in the "Ra Value" column of the table.

#### 4-23. AC Ammeter Accuracy Test

**4-24. Equipment Required.** The AC Calibrator (Fluke Model 5200A), Meter Calibrator (-hp- Model 6920B), and Resistor Decade Box (General Radio Model GR 1433-H).

**4-25. Test Procedure.** The limits for the Complete AC Ammeter Accuracy Test are listed in Table 4-10 and Table 4-11. There is no abbreviated test for the ac current function. Make sure the 3466A has been warmed up for at least 15 minutes. Do the following:

- a. Connect the AC Calibrator to the 3466A as shown in Figure 4-5. Use the Resistor Decade Box to select the value of  $R_a$ .
- b. Select the 100k ohm resistor in the Resistor Decade Box for the  $R_a$  value.
- c. Set the 3466A to the acA function and the  $200\mu\text{A}$  range.

d. Use the AC Calibrator and the Resistor Decade Box (for resistor values  $R_a$ ) to check the 3466A  $200\mu\text{A}$  to 20mA ranges as follows:

1. Refer to Table 4-10. Make sure the 3466A is set to the  $200\mu\text{A}$  range (first range listed in the "Range" column).
2. Set the AC Calibrator output to the voltage and frequency shown in the "AC Calibrator Output/Frequency" columns of the table.
3. Check and make sure the 3466A is within the limits shown in the "Test Limits" columns of the table. Check the ranges that follow in the same manner. Make sure that the correct  $R_a$  resistor is selected, as shown in the "Ra Value" column of the table, for the other ranges.

e. Use the Meter Calibrator to check the 200mA and 2000mA ranges next, as follows:

1. Remove the AC Calibrator and Resistor Decade Box from the 3466A.
2. Connect the Meter Calibrator to the 3466A as shown in Figure 4-6.
3. Refer to Table 4-11 and set the 3466A to the 200mA range (first range listed in the "Range" column).
4. Set the Meter Calibrator output to the current shown in the "Current Output" column of the table.
5. Check and make sure the 3466A is within the limits shown in the "Test Limits" columns of the table. Check the 2000mA range that follows in the same manner.

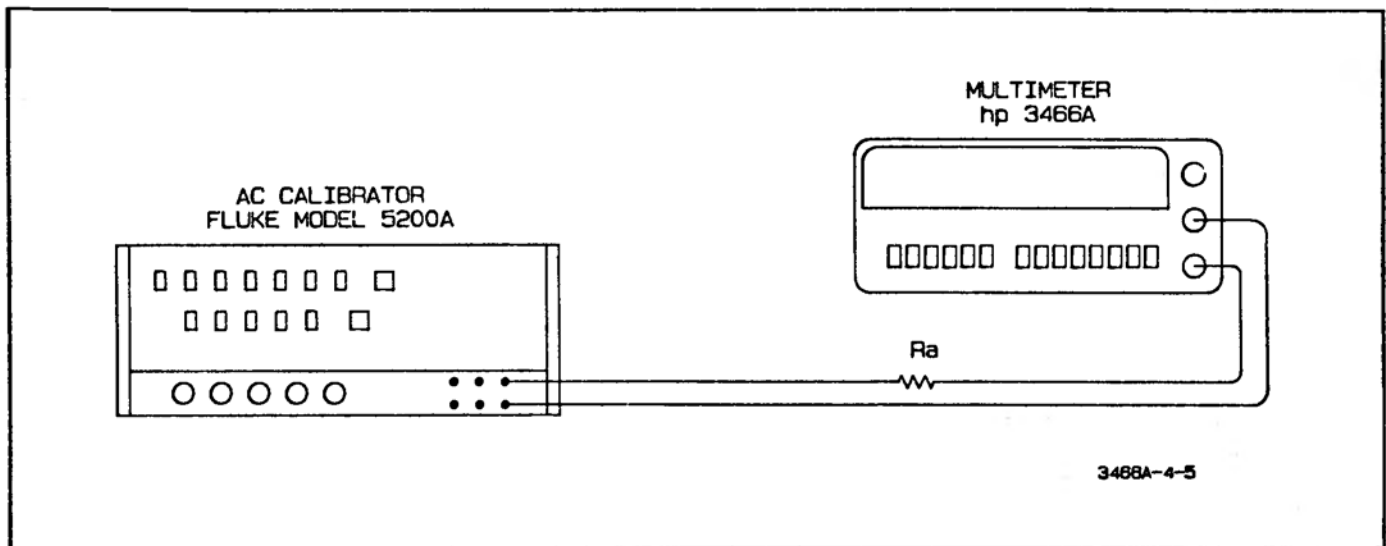

**Figure 4-5. AC Ammeter Accuracy Test (200µA to 20mA Ranges)**

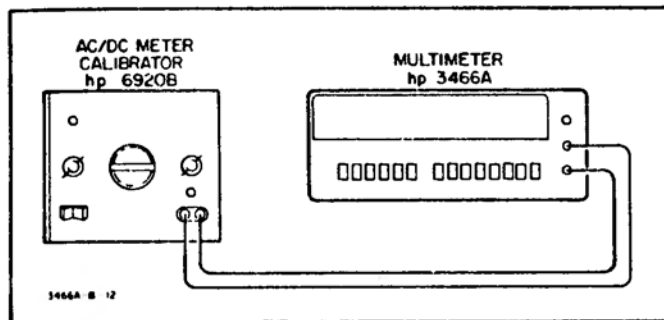

**Figure 4-6. AC Ammeter Accuracy Test (200mA and 2000mA Ranges)**

**Table 4-10. AC Ammeter Accuracy Test (200µA to 20mA Ranges)**

Range	Current Level	Ra Value	AC Calibrator		Test Limits	
			Output	Frequency	High	Low
20µA	20µA	100k, ± .1%	2.002V	100Hz	20.53µA	19.47µA
2mA	0.2mA	100k, ± .1%	20.02V	100Hz	.2053mA	.1947mA
20mA	2mA	10k, ± .1%	20.02V	100Hz	2.053mA	1.947mA

**Table 4-11. AC Ammeter Accuracy Test (200mA and 2000mA Ranges)**

Range	Current Output	Test Limits	
		High	Low
200mA	20mA	20.53mA	19.47mA
	50mA	50.80mA	49.20mA
	100mA	101.25mA	98.75mA
2000mA	200mA	205.3mA	194.7mA
	500mA	508.0mA	492.0mA
	1000mA	1014.0mA	986.0mA

**4-26. True RMS Ammeter Accuracy Test**

**4-27. Equipment Required.** The following equipment is required to do the test.

- DC Standard (Systron Donner Model M107)
- AC Calibrator (Fluke Model 5200A)
- Decade Resistance Box (General Radio Model GR 1433-H)

**4-28. Test Procedure.** The limits for the Complete True RMS Ammeter Accuracy Test are listed in Table 4-12. There is no abbreviated test for the true RMS current function. Make sure the 3466A has been warmed up for at least 15 minutes. Do the following:

- a. Set the 3466A to the dc + ac amps function by simultaneously pressing the buttons for the dcA and acA functions.
- b. Connect the DC Standard and AC Calibrator to the 3466A as shown in Figure 4-7. Use the Resistor Decade Box to select the value of Ra.
- c. Select the 100k ohm resistor in the Resistor Decade Box for the Ra value.
- d. Use the DC Standard, AC Calibrator, and Resistor Decade Box (for the Ra resistor values) to check the 3466A ranges as follows:

1. Refer to Table 4-12 and set the 3466A to the 200µA range (first range listed in the "Range" column).
2. Set the DC Calibrator output to the voltage listed in the "DC Standard Output" column and set the AC Calibrator output to the voltage and frequency shown in the "AC Calibrator Output/Frequency" columns of the table.

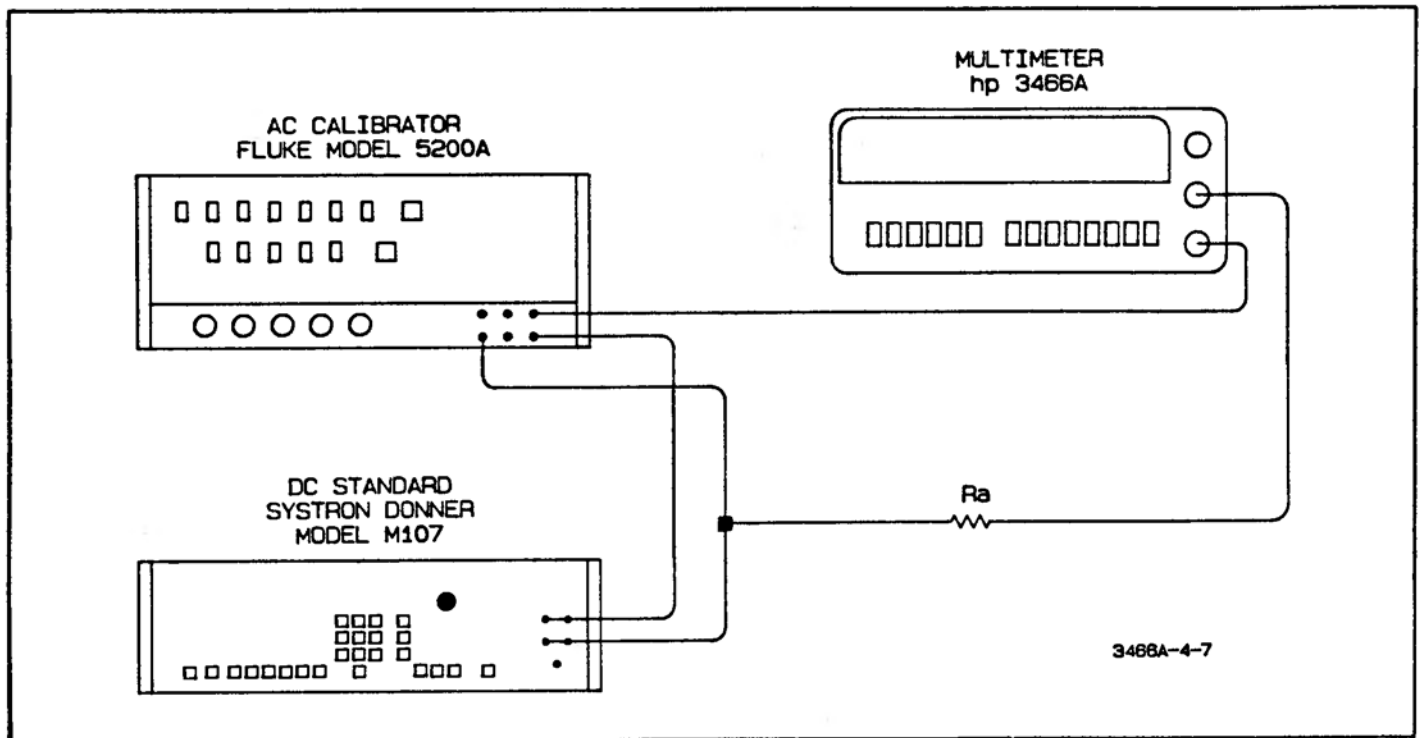

Figure 4-7. True RMS Ammeter Accuracy Test

3. Check and make sure the 3466A is within the limits shown in the "Test Limits" columns of the table. Check the ranges that follow in the same manner. Make sure that the correct Ra resistor is selected (as shown in the "Ra Value" column of the table) for the other ranges.

c. Set all the switches on the Resistor Decade Box to zero.

d. Using a small flat blade screwdriver, adjust the ohms zero adjustment on the front panel of the 3466A for a 0.000 reading on the display.

e. Use the Resistor decade Box to check the 3466A ranges as follows:

Table 4-12. True RMS Ammeter Accuracy Test

Range	DC Standard Output	AC Calibrator		Ra Value	Test Limits	
		Output	Frequency		High	Low
200µA	2V	2V	100Hz	100k..1%	29.22µA	26.78µA
2mA	20V	20V	30Hz	100k..1%	.2948mA	.2703mA
20mA	20V	20V	100Hz	10k..1%	2.948mA	2.703mA

4-29. Ohmmeter Accuracy Test

4-30. Equipment Required. The Resistor Decade Box (General Radio Model GR 1433-H) is required for this test. The resistor box should be calibrated within a tolerance of ±.005%.

4-31. Test Procedure. The limits for the Abbreviated Ohmmeter Accuracy Test are listed in Table 4-13 and the limits for the Complete Ohmmeter Accuracy Test are listed in Table 4-14. Make sure the 3466A has been warmed up for at least 15 minutes. Do the following:

a. Set the 3466A to the ohms function and the 20 ohms range.

b. Connect the Resistor Decade Box to the 3466A as shown in Figure 4-8.

1. Refer to Table 4-13 or Table 4-14. Make sure the 3466A is set to the 20 ohms range (first range listed in the "Range" column).

2. Set the Resistor Decade Box to the resistance value shown in the "Standard Resistor" column of the appropriate table.

3. Check and make sure the 3466A is within the limits shown in the "Test Limits" columns of the table. Check the ranges that follow in the same manner.

Table 4-13. Abbreviated Ohmmeter Accuracy Test

Range	Standard Resistance	Test Limits	
		High	Low
20 ohms	19 ohms	19.017	18.983
200 ohms	190 ohms	190.17	189.83
2k ohms	1.9k ohms	1.9007k	1.8993k
20k ohms	19k ohms	19.007k	18.993k
200k ohms	190k ohms	190.07k	189.93k
2000k ohms	1.9M ohms	1900.9k	1899.1k
20M ohms	10M ohms	10.016M	9.984M



**Table 4-14. Complete Ohmmeter Accuracy Test**

Range	Standard Resistance	Test Limits	
		High	Low
20 ohms	1 ohm	1.003	.997
	10 ohms	10.010	9.990
	19 ohms	19.017	18.983
200 ohms	19 ohms	19.04	18.96
	50 ohms	50.06	49.94
	190 ohms	190.17	189.83
2k ohms	190 ohms	.1902k	.1898k
	1k ohms	1.0004k	.9996k
	1.9k ohms	1.9007k	1.8993k
20k ohms	1.9k ohms	1.902k	1.898k
	5k ohms	5.003k	4.998k
	19k ohms	19.007k	18.993k
200k ohms	19k ohms	19.02k	18.98k
	100k ohms	100.04k	99.96k
	190k ohms	190.07k	189.93k
2000k ohms	190k ohms	190.2k	189.8k
	500k ohms	500.3k	499.7k
	1.9M ohms	1900.9k	1899.1k
20M ohms	1.9M ohms	1.904M	1.896M
	5M ohms	5.009M	4.992M
	10M ohms	10.016M	9.984M

**4-32. AC Normal Mode Rejection Test (NMRR)**

4-33. The purpose of this test is to verify that the 3466A can make accurate dc volts measurements in the presence of ac voltages at power line frequencies. The definition of NMRR and resultant formula are as follows:

Definition: AC Normal Mode Rejection is the ratio of the peak normal-mode voltage to the resultant error in reading.

NMRR (dB) =

$$20 \text{ Log}_{10} \left[ \frac{\text{Peak AC Interfering Voltage}}{\text{Change in DCV reading (i.e., peak roll)}} \right]$$

4-34. **Equipment Required.** The AC Calibrator (Fluke Model 5200A) and the Electronic Counter (-hp- Model 5381A).

4-35. **Test Procedure.** Do the following:

- With the 3466A not connected to any test equipment at this time, connect the test equipment to each other, as shown in Figure 4-9.
- Set the AC Calibrator for a 7.07V rms at 60Hz output.
- Using the electronic counter as a monitor, adjust the frequency of the AC Calibrator until it reads 60Hz  $\pm 0.1\%$  (Period: 16650 $\mu$ S to 16683 $\mu$ S) on the counter.
- Set the 3466A to the dc volts function and 20V range.
- Connect a short across the 3466A V and COM input terminals. Note the reading on the display.
- Remove the short from the input terminals and connect the AC Calibrator and Electronic Counter to the 3466A input terminals.

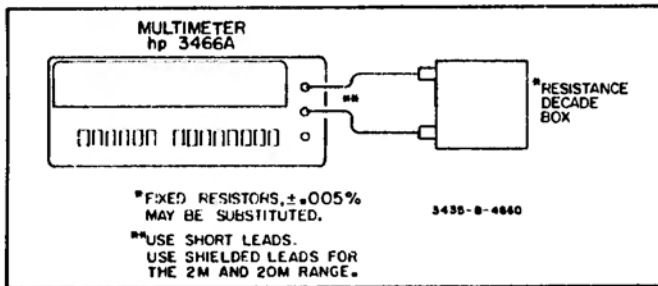

**Figure 4-8. Ohms Accuracy Test**

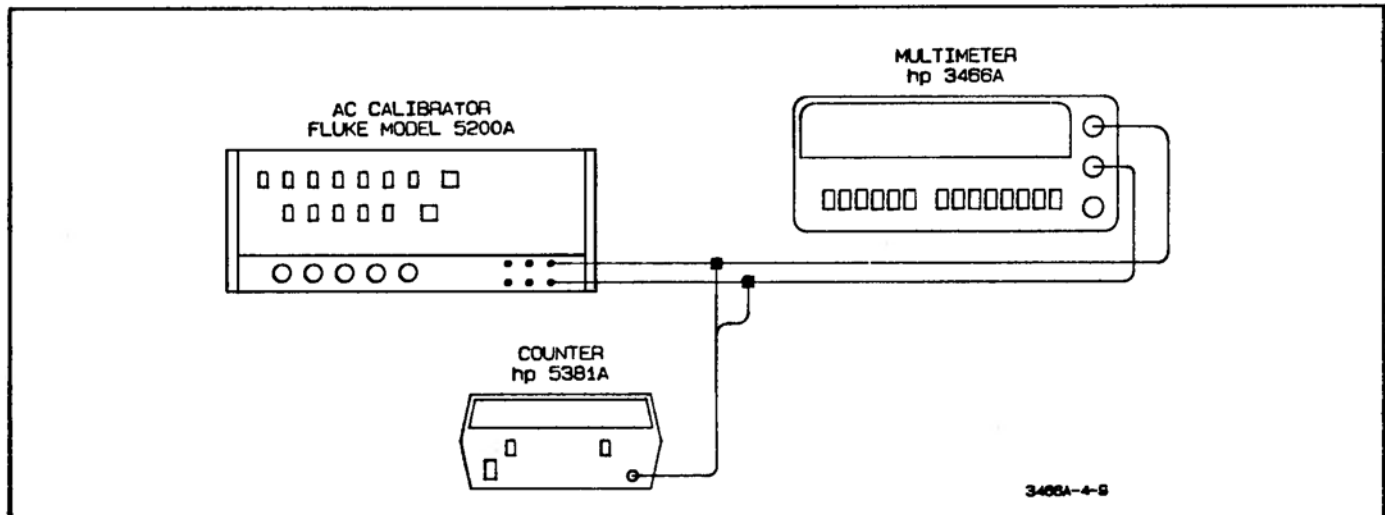

**Figure 4-9. AC Normal Mode Rejection Test**

g. The 3466A reading should not change more than 0.020V (20 digits) from the reading noted in step e. This verifies an AC Normal Mode Rejection ratio of less than or equal to 54dB.

h. Repeat steps d through g for an AC Calibrator output frequency of 50Hz ±0.1% as monitored on the Electronic Counter (Period: 19980µS to 20020µS).

**4-36. AC Common Mode Rejection Test (CMRR)**

4-37. The purpose of this test is to verify that the 3466A can make accurate ac volts measurements with interfering signals at power line frequencies applied simultaneously to the input terminals. The CMRR formula is as follows:

$$CMRR (dB) = 20 \text{ Log}_{10} \left[ \frac{\text{RMS AC Interfering Voltage}}{\text{Change in ACV reading}} \right]$$

4-38. **Equipment Required.** The AC Calibrator (Fluke Model 5200A) and the Electronic Counter (-hp- Model 5381A).

4-39. **Test Procedure.** Make sure the 3466A is ac powered, not battery powered, for this test. Do the following:

**NOTE**

*The 3466A MUST be ac powered (not battery powered) for the AC Common Mode Rejection Test.*

a. Set the 3466A to the ac volts function and the 2V range.

b. Connect a 1k ohm resistor between the 3466A's V and COM input terminals (see Figure 4-10). Note the reading on the display.

c. Set the AC Calibrator for a 10V rms at 50Hz output. Then connect the 3466A to the test equipment, as shown in Figure 4-10. Make sure the 1k ohm resistor is still connected to the 3466A input terminals and that the power line is grounded (see Figure 4-10).

d. Monitor the AC Calibrator output frequency on the Electronic Counter and make sure it is 50Hz ±0.1% (Period: 19980µS to 20020µS).

e. Make sure the reading on the 3466A display does not change more than 0.0100V (100 digits) from the reading noted in step b. This verifies an AC Common Mode Rejection ratio of less than or equal to 60dB.

f. Repeat steps a through e for an AC Calibrator output frequency of 60Hz ±0.1% as monitored on the Electronic Counter (Period: 16650µS to 16683µS).

**4-40. DC Common Mode Rejection Test (DCV CMRR)**

4-41. The purpose of this test is to verify that the 3466A can make accurate dc volts measurements with dc interfering voltages applied simultaneously to the input terminals. The DC CMRR formula is as follows:

$$DC \text{ CMRR } (dB) = 20 \text{ Log}_{10} \left[ \frac{\text{DC Interfering Voltage}}{\text{Change in DCV reading}} \right]$$

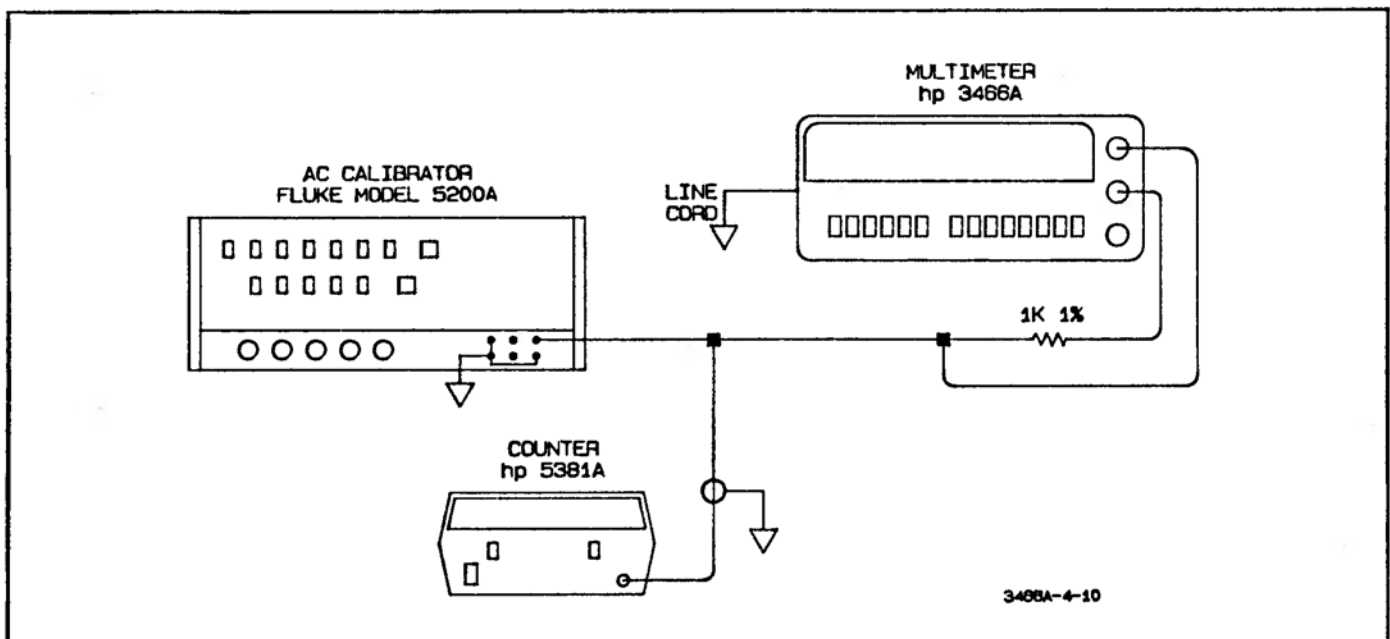

**Figure 4-10. AC Common Mode Rejection Test**

**4-42. Equipment Required.** The DC Standard (Systron Donner Model M107).

**4-43. Test Procedure.** Make sure the 3466A is ac powered, not battery powered, for this test. Do the following:

**NOTE**

*The 3466A MUST be ac powered (not battery powered) for the DC Common Mode Rejection Test.*

a. Set the 3466A to the dc volts function and the 20mV

range.

b. Connect a 1k ohm resistor between the 3466A's V and COM input terminals (see Figure 4-11). Note the reading on the display.

c. Turn the DC Standard's output off. Then connect the DC Standard to the 3466A V input terminal as shown in Figure 4-11.

d. Set the DC Standard for a +500V dc output and turn its output on. Make sure the reading on the 3466A display does not change more than 0.050mV (50 digits) from the reading noted in step b. This verifies a DC Common Mode Rejection ratio of less than or equal to 140dB.

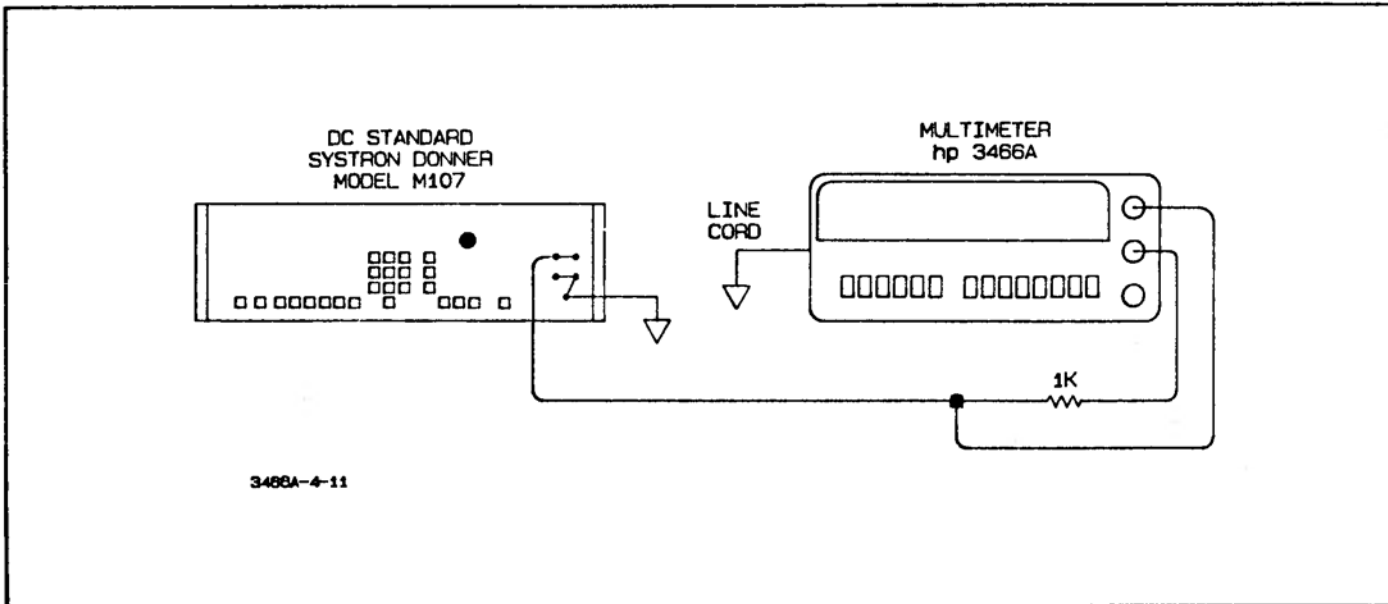

**Figure 4-11. DC Common Mode Rejection Test**

## ABBREVIATED PERFORMANCE TEST CARD

Hewlett-Packard Model 3466A Multimeter

Serial No. \_\_\_\_\_

Test Performed By \_\_\_\_\_

Date \_\_\_\_\_

3466A Input	3466A Range	High Limit	Reading	Low Limit	Test Pass	Test Fail
<b>DC Voltmeter Accuracy Test (Paragraph 4-11)</b>						
Zero Adj.	20mV					
+ 19mV	20mV	+ 19.013mV	_____	+ 18.988mV	_____	_____
- 190mV	200mV	- 190.10mV	_____	- 189.90mV	_____	_____
+ 1.9V	2V	+ 1.9007V	_____	+ 1.8993V	_____	_____
+ 19V	20V	+ 19.007V	_____	+ 18.993V	_____	_____
- 19V	20V	- 19.007V	_____	- 18.993V	_____	_____
+ 190V	200V	+ 190.07V	_____	+ 189.93V	_____	_____
+ 1000V	1200V	+ 1000.7V	_____	+ 999.4V	_____	_____
<b>AC Voltmeter Accuracy Test (Paragraph 4-14)</b>						
20mV, 20Hz	200mV	20.90mV	_____	19.10mV	_____	_____
1.9V, 100kHz	2V	1.9530V	_____	1.8470V	_____	_____
2V, 200Hz	20V	2.026V	_____	1.974V	_____	_____
2V, 10kHz	20V	2.026V	_____	1.974V	_____	_____
19V, 200Hz	20V	19.077V	_____	18.923V	_____	_____
19V, 10kHz	20V	19.077V	_____	18.923V	_____	_____
19V, 100kHz	20V	19.530V	_____	18.470V	_____	_____
190V, 20Hz	200V	194.30V	_____	185.70V	_____	_____
200V, 10kHz	1200V	202.6V	_____	197.4V	_____	_____
<b>True RMS Voltmeter Accuracy Test (Paragraph 4-17)</b>						
20mV, 20kHz	200mV	29.37mV	_____	27.20mV	_____	_____
20V, 20kHz	20V	28.64V	_____	27.92V	_____	_____
20V, 100kHz	200V	30.85V	_____	25.72V	_____	_____
<b>DC Ammeter Accuracy Test (Paragraph 4-20)</b>						
100 $\mu$ A	200 $\mu$ A	100.09 $\mu$ A	_____	99.91 $\mu$ A	_____	_____
1mA	2mA	1.0009mA	_____	.9991mA	_____	_____
10mA	20mA	10.009mA	_____	9.991mA	_____	_____
100mA	200mA	100.17mA	_____	99.83mA	_____	_____
800mA	2000mA	804.2mA	_____	795.8mA	_____	_____
<b>Dhmmeter Accuracy Test (Paragraph 4-29)</b>						
Zero Adj.	20 ohms					
19 ohms	20 ohms	19.017	_____	18.983	_____	_____
190 ohms	200 ohms	190.17	_____	189.83	_____	_____
1.9k ohms	2k ohms	1.9007k	_____	1.8993k	_____	_____
19k ohms	20k ohms	19.007k	_____	18.993k	_____	_____
190k ohms	200k ohms	190.07k	_____	189.93k	_____	_____
1.9M ohms	2000k ohms	1900.9k	_____	1899.1k	_____	_____
10M ohms	20M ohms	10.016M	_____	9.984M	_____	_____

# PERFORMANCE TEST CARD

## Hewlett-Packard Model 3466A Multimeter

Serial No. \_\_\_\_\_

Test Performed By \_\_\_\_\_

Date \_\_\_\_\_

3466A Input	3466A Range	High Limit	Reading	Low Limit	Test Pass	Test Fail
<b>DC Voltmeter Accuracy Test (Paragraph 4-11)</b>						
Zero Adj.	20mV		_____			
Zero Adj.	20mV		_____			
- 1mV	20mV	- 1.004mV	_____	- .0997mV	_____	_____
- 5mV	20mV	- 5.006mV	_____	- 4.995mV	_____	_____
+ 10mV	20mV	+ 10.008mV	_____	+ 9.992mV	_____	_____
+ 19mV	20mV	+ 19.013mV	_____	+ 18.988mV	_____	_____
+ 19mV	200mV	+ 19.03mV	_____	+ 18.97mV	_____	_____
+ 50mV	200mV	+ 50.04mV	_____	+ 49.96mV	_____	_____
- 100mV	200mV	- 100.06mV	_____	- 99.94mV	_____	_____
- 190mV	200mV	- 190.10mV	_____	- 189.90mV	_____	_____
- 190mV	2V	- .1902V	_____	- .1898V	_____	_____
- 500V	2V	- .5003V	_____	- .4998V	_____	_____
+ 1.0V	2V	+ 1.0004V	_____	+ .9996V	_____	_____
+ 1.9V	2V	+ 1.9007V	_____	+ 1.8993V	_____	_____
+ 1.9V	20V	+ 1.902V	_____	+ 1.898V	_____	_____
+ 5.0V	20V	+ 5.003V	_____	+ 4.998V	_____	_____
- 10V	20V	- 10.004V	_____	- 9.996V	_____	_____
- 19V	20V	- 19.007V	_____	- 18.993V	_____	_____
+ 19V	20V	+ 19.007V	_____	+ 18.993V	_____	_____
- 19V	200V	- 19.02V	_____	- 18.98V	_____	_____
- 50V	200V	- 50.03V	_____	- 49.98V	_____	_____
+ 100V	200V	+ 100.04V	_____	+ 99.96V	_____	_____
+ 190V	200V	+ 190.07V	_____	+ 189.93V	_____	_____
+ 1000V	1200V	+ 1000.7V	_____	+ 999.4V	_____	_____
<b>AC Voltmeter Accuracy Test (Paragraph 4-14)</b>						
20mV, 20Hz	200mV	20.90mV	_____	19.10mV	_____	_____
20mV, 20kHz	200mV	20.60mV	_____	19.40mV	_____	_____
20mV, 50Hz	200mV	20.26mV	_____	19.74mV	_____	_____
50mV, 100kHz	200mV	52.50mV	_____	47.50mV	_____	_____
50mV, 10kHz	200mV	50.35mV	_____	49.65mV	_____	_____
50mV, 30Hz	200mV	50.80mV	_____	49.20mV	_____	_____
100mV, 20Hz	200mV	102.50mV	_____	97.50mV	_____	_____
100mV, 20kHz	200mV	101.40mV	_____	98.60mV	_____	_____
100mV, 50Hz	200mV	100.50mV	_____	99.50mV	_____	_____
.19V, 30Hz	200mV	192.20mV	_____	187.80mV	_____	_____
.2V, 30Hz	2V	.2050V	_____	.1950V	_____	_____
1.9V, 100kHz	2V	1.9530V	_____	1.8470V	_____	_____
1V, 20kHz	2V	1.0050V	_____	.9950V	_____	_____
2V, 20Hz	20V	2.090V	_____	1.910V	_____	_____
2V, 200Hz	20V	2.026V	_____	1.974V	_____	_____
2V, 30Hz	0V	2.050V	_____	1.950V	_____	_____
2V, 50Hz	20V	2.026V	_____	1.974V	_____	_____
2V, 10kHz	20V	2.026V	_____	1.974V	_____	_____
5V, 10kHz	20V	5.035V	_____	4.965V	_____	_____
5V, 20kHz	20V	5.090V	_____	4.910V	_____	_____
19V, 200Hz	20V	19.077V	_____	18.923V	_____	_____
19V, 10kHz	20V	19.077V	_____	18.923V	_____	_____
19V, 100kHz	20V	19.530V	_____	18.470V	_____	_____
20V, 10kHz	200V	20.60V	_____	19.40V	_____	_____
100V, 50Hz	200V	100.50V	_____	99.50V	_____	_____
190V, 20Hz	200V	194.30V	_____	185.70V	_____	_____
200V, 10kHz	1200V	202.6V	_____	197.4V	_____	_____
500V, 30Hz	1200V	508.0V	_____	492.0V	_____	_____
1000V, 10kHz	1200V	1005.0V	_____	995.0V	_____	_____

# PERFORMANCE TEST CARD

## Hewlett-Packard Model 3466A Multimeter

Serial No. \_\_\_\_\_

Test Performed By \_\_\_\_\_

Date \_\_\_\_\_

3466A Input	3466A Range	High Limit	Reading	Low Limit	Test Pass	Test Fail
<b>True RMS Voltmeter Accuracy Test (Paragraph 4-17)</b>						
20mV, 20kHz	200mV	29.37mV	_____	27.20mV	_____	_____
50mV, 50Hz	200mV	72.21mV	_____	69.20mV	_____	_____
100mV, 20kHz	200mV	143.63mV	_____	139.20mV	_____	_____
.2V, 100kHz	2V	.3085V	_____	.2572V	_____	_____
.5V, 30Hz	2V	.7221V	_____	.6920V	_____	_____
1V, 10kHz	2V	1.4363V	_____	1.3920V	_____	_____
2V, 20Hz	20V	2.937V	_____	2.720V	_____	_____
5V, 50Hz	20V	7.221V	_____	6.920V	_____	_____
10V, 20kHz	20V	14.363V	_____	13.920V	_____	_____
20V, 100kHz	200V	30.85V	_____	25.72V	_____	_____
50V, 30Hz	200V	72.21V	_____	69.20V	_____	_____
100V, 10kHz	200V	143.63V	_____	139.20V	_____	_____
<b>DC Ammeter Accuracy Test (Paragraph 4-20)</b>						
10 $\mu$ A	200 $\mu$ A	10.03 $\mu$ A	_____	9.97 $\mu$ A	_____	_____
50 $\mu$ A	200 $\mu$ A	50.06 $\mu$ A	_____	49.95 $\mu$ A	_____	_____
100 $\mu$ A	200 $\mu$ A	100.09 $\mu$ A	_____	99.91 $\mu$ A	_____	_____
.1mA	2mA	.1003mA	_____	.0997mA	_____	_____
.5mA	2mA	.5006mA	_____	.4995mA	_____	_____
1mA	2mA	1.0009mA	_____	.9991mA	_____	_____
1mA	20mA	1.003mA	_____	.997mA	_____	_____
5mA20	mA	5.006mA	_____	4.995mA	_____	_____
10mA	20mA	10.009mA	_____	9.991mA	_____	_____
10mA	200mA	10.04mA	_____	9.997mA	_____	_____
50mA	200mA	50.10mA	_____	49.91mA	_____	_____
100mA	200mA	100.17mA	_____	99.83mA	_____	_____
100mA	2000mA	100.7mA	_____	99.3mA	_____	_____
500mA	2000mA	502.7mA	_____	497.3mA	_____	_____
800mA	2000mA	804.2mA	_____	795.8mA	_____	_____
<b>AC Ammeter Accuracy Test (Paragraph 4-23)</b>						
20 $\mu$ A, 100Hz	200 $\mu$ A	20.53 $\mu$ A	_____	19.47 $\mu$ A	_____	_____
.2mA, 100Hz	2mA	.2053mA	_____	.1947mA	_____	_____
2mA, 100Hz	20mA	2.053mA	_____	1.947mA	_____	_____
20mA	200mA	20.53mA	_____	19.47mA	_____	_____
50mA	200mA	50.80mA	_____	49.20mA	_____	_____
100mA	200mA	101.25mA	_____	98.75mA	_____	_____
200mA	2000mA	205.3mA	_____	194.7mA	_____	_____
500mA	2000mA	508.0mA	_____	492.0mA	_____	_____
1000mA	2000mA	1014.0mA	_____	986.0mA	_____	_____
<b>True RMS Ammeter Accuracy Test (Paragraph 4-26)</b>						
2V, 100Hz	200 $\mu$ A	29.22 $\mu$ A	_____	26.78 $\mu$ A	_____	_____
20V, 30Hz	2mA	.2948mA	_____	.2703mA	_____	_____
20V, 100Hz	20mA	2.948mA	_____	2.703mA	_____	_____

# PERFORMANCE TEST CARD

## Hewlett-Packard Model 3466A Multimeter

Serial No. \_\_\_\_\_

Test Performed By \_\_\_\_\_

Date \_\_\_\_\_

3466A Input	3466A Range	High Limit	Reading	Low Limit	Test Pass	Test Fail
<b>Ohmmeter Accuracy Test (Paragraph 4-29)</b>						
Zero Adj.	20 ohms		_____		_____	_____
1 ohm	20 ohms	1.003	_____	.997	_____	_____
10 ohms	20 ohms	10.010	_____	9.990	_____	_____
19 ohms	20 ohms	19.017	_____	18.983	_____	_____
19 ohms	200 ohms	19.04	_____	18.96	_____	_____
50 ohms	200 ohms	50.06	_____	49.94	_____	_____
190 ohms	200 ohms	190.17	_____	189.83	_____	_____
190 ohms	2k ohms	.1902k	_____	.1898k	_____	_____
1k ohms	2k ohms	1.0004k	_____	.9996k	_____	_____
1.9k ohms	2k ohms	1.9007k	_____	1.8993k	_____	_____
1.9k ohms	20k ohms	1.902k	_____	1.898k	_____	_____
5k ohms	20k ohms	5.003k	_____	4.998k	_____	_____
19k ohms	20k ohms	19.007k	_____	18.993k	_____	_____
19k ohms	200k ohms	19.02k	_____	18.98k	_____	_____
100k ohms	200k ohms	100.04k	_____	99.96k	_____	_____
190k ohms	200k ohms	190.07k	_____	189.93k	_____	_____
190k ohms	2000k ohms	190.2k	_____	189.8k	_____	_____
500k ohms	2000k ohms	500.3k	_____	499.7k	_____	_____
1.9M ohms	2000k ohms	1900.9k	_____	1899.1k	_____	_____
1.9M ohms	20M ohms	1.904M	_____	1.896M	_____	_____
5M ohms	20M ohms	5.009M	_____	4.992M	_____	_____
10M ohms	20M ohms	10.016M	_____	9.984M	_____	_____

# SECTION V

## ADJUSTMENTS

### 5-1. INTRODUCTION

5-2. This section of the manual has Pre-Adjustment Information and Adjustment Procedures for the 3466A. After performing the adjustments, the 3466A should meet the specifications listed in Table 1-1.

### 5-3. EQUIPMENT REQUIRED

5-4. The required test equipment to do the adjustment procedures is listed in Table 5-1. If any of the required equipment is not available, use substitute equipment that meets the critical requirements listed in the table.

### 5-5. ADJUSTMENT INTERVAL

5-6. Adjustments should be performed at least once a year to ensure proper calibration of the 3466A.

**WARNING**

*The adjustment procedures are to be performed only by service-trained personnel who are aware of the hazards involved. To avoid electrical shock, do not perform any adjustments unless you are qualified to do so.*

**CAUTION**

*Wear clean cotton gloves when working on the circuit boards or switches. Contamination from finger prints on high impedance points may degrade the performance of the 3466A. Nylon gloves should not be worn due to the possibility of static charge buildup.*

**CAUTION**

*The hybrid circuits in the 3466A may be permanently damaged by static discharge from a hand or tool when the instrument is disassembled. Follow the following procedure to prevent possible damage.*

- 1. Ground the hand while disassembling the 3466A. Conductive wristbands (-hp- Part No. 00970-67900) are available for this purpose. It is also suggested to use anti-static bench and floor mats.*
- 2. Attach the 3466A COM terminal to earth ground. Touch all tools to earth ground to remove static charges before using them on the instrument.*
- 3. Use a soldering iron with a grounded tip.*

**Table 5-1. Required Test Equipment**

Instrument Type	Required Characteristics	Recommended Model
DC Voltage Standard	Output: 1mV to 1000V Accuracy: $\pm 0.02\%$	Systron Donner Model M107
AC Calibrator	Output: 1.9V to 19V Frequency: 200Hz to 100kHz Accuracy: $\pm 0.1\%$ (mid band)	Fluke Model 5200A
DC Power Supply	Output Voltage: 10V Output Current: 1A	-hp- Model 6294A
Digital Multimeter	Accuracy: $\pm .01\%$ Input Resistance: 10M ohms	-hp- Model 3468A
Resistor Decade Box	Resistors: 1 ohm to 1M ohms Accuracy: $\pm 0.005\%$	General Radio Model GR1433-H
Resistor	1 ohm $\pm 0.02\%$	General Radio 1440-9601



## 5-7. PRE-ADJUSTMENT INFORMATION

5-8. The following tells how to disassemble the 3466A which is necessary to perform the adjustment procedures. The locations of the adjustments are also given.

## 5-9. Instrument Disassembly Instructions

5-10. Do the following:

- a. Disconnect the 3466A's power cord and turn the instrument off.
- b. With the 3466A in the inverted position, locate and loosen the four screws at the bottom of the instrument.
- c. Carefully return the 3466A to the upright position with the front panel facing you.

### NOTE

*The battery and charger circuitry are located in the top shell assembly and are connected to the main printed circuit assembly by a 9 lead cable. To avoid possible damage to the cable, remove the top shell slowly.*

*If the battery cable is disconnected, the 3466A will not operate unless JM700 is installed (see paragraph 8-87, step f-3).*

d. Remove the top shell vertically and place it at the right of the bottom assembly in an inverted position. If the battery and charger circuitry is installed, make sure the top shell is not lifted up too high.

e. Reconnect the power cord to the 3466A and turn the instrument on. The instrument is now ready for adjustments.

## 5-11. Test Points and Adjustment Locations

5-12. Fold out and refer to Figure 5-2 while doing the adjustments. The figure shows the locations of the test points, test jumpers, adjustments, and various connectors.

## 5-13. ADJUSTMENT PROCEDURES

5-14. Make sure the 3466A is set for ac power operation (not battery) for the adjustment procedures. Also make sure the 3466A has been warmed up for at least 15 minutes before doing any adjustments. The adjustments should be performed in the following order.

① +7V Power Supply Adjustment (R717)

Battery Charger Voltage Adjustment (R818)

② Input Amplifier Zero Adjustment (R152)

③ Post Amplifier Zero Adjustment (R205)

④ 19k ohms Adjustment (R416)

⑤ 19 ohms Adjustment (R926/R406)

⑥ 10M ohms Adjustment (R428)

⑦ 19V DC Adjustment (R602)

2V DC Zero Offset Adjustment (R118\*/R119\*)

⑧ Zero Input DC Adjustment (R134)

⑨ 19V AC, 200Hz Adjustment (R303)

⑩ 1.9V AC, 200Hz Adjustment (R302)

⑪ 19V AC, 10kHz Adjustment (R102)

⑫ 1.9V AC, 10kHz Adjustment (C102)

⑬ 100kHz Frequency Response Adjustment (R717)

1A DC Adjustment (R660)

5-15. ① +7V Power Supply Adjustment (R717)

5-16. **Equipment Required.** The test Digital Multimeter (-hp- Model 3468A) set to the dc volts function.

5-17. **Adjustment Procedure.** The following procedure adjusts the 3466A's +7V power supply and also checks various power supply voltages. Do the following:

a. Connect the HI Input of the test Digital Voltmeter to the 3466A's +7V test pad (see Figure 5-2).

b. Adjust R717 for a +7V  $\pm 0.01V$  (+6.99V to +7.01V) reading on the test multimeter.

c. Using the test meter, check the power supply voltages listed in Table 5-2 and make sure they are within the tolerances listed.

**Table 5-2. Power Supply Voltage Checks**

Test Pad	Voltage
-7V	-6.9V to -7.1V
-2.5V	-2.3V to -2.7V (Substrate)
+6.3V	+5.6V to +7.5V (V Bat)
+5V	+5V to +5.65V (Reference)

5-18. **Battery Charge Voltage Adjustment (R818)**

### NOTE

*The Battery Charger Voltage Adjustment is NOT for Option 001 3466A Multimeters.*

**5-19. Equipment Required.** The test Digital Multimeter (-hp- Model 3468A) set to the dc volts function.

**5-20. Adjustment Procedure.** The following procedure adjusts the 3466A's Battery Charge Voltage and is NOT for Option 001 instruments. Do the following:

- a. Disconnect the ac power line cord from the 3466A.
- b. Lift one end of fuse F801 to open the battery circuit.
- c. Connect the test Digital Multimeter to the battery's positive terminal and common.
- d. Reconnect the ac power line cord to the 3466A and turn the instrument on.
- e. Adjust R818 for a 7.2V reading on the test meter.
- f. Replace fuse F801.

**5-21. ② Input Amplifier and ③ Post Amplifier Zero Adjustments (R152 and R205)**

**5-22. Equipment Required.** The test Digital Multimeter (-hp- Model 3468A) set to the dc volts function.

**5-23. Adjustment Procedure.** The following procedures adjust the outputs of the Input and Post Amplifiers to zero. Do the following:

- a. Set the 3466A to the dc + ac volts function.
- b. Connect a short across the V and COM input terminals.
- c. Connect the test multimeter to jumper J101.
- d. Adjust R152 for a  $0V \pm 100\mu V$  reading on the test meter.
- e. Connect the test multimeter to jumper J201.
- f. Adjust R205 for a  $0V \pm 200\mu V$  reading on the test meter.
- g. Disconnect the test meter from the instrument.

**5-24. ④ 19k ohms, ⑤ 19 ohms, and ⑥ 10M ohms Adjustments (R416, R926/R406, and R428)**

**5-25. Equipment Required.** The Resistor Decade Box (General Radio Model GR 1433-H).

**5-26. Adjustment Procedure.** The following procedure calibrates the 3466A's ohms function. Do the following:

- a. Set the 3466A to the ohms function and the 20k ohm range.

- b. Set the Resistor Decade Box to 19k ohms and connect it to the 3466A's V and COM input terminals, as shown in Figure 4-8 (see Section IV). Use shielded cables to minimize noisy readings.

- c. Adjust R416 for a 19.000k ohms reading on the display.
- d. Set the 3466A to the 20 ohms range.
- e. Set the Resistor Decade Box to 0 ohm.
- f. Adjust R926 for a 0.000 ohm reading on the display.
- g. Set the Resistor Decade Box to 19 ohms.
- h. Adjust R406 for a 19.000 ohms reading on the display.
- i. Set the 3466A to the 20M ohms range.
- j. Set the Resistor Box to 10M ohms.
- k. Adjust R428 for a 10.000M ohms reading on the display.
- l. Disconnect the Decade Resistor Box from the 3466A.

**5-27. ⑦ 19V DC Adjustment (R602)**

**5-28.** There are two adjustments to this procedure: a 19V DC Fine Adjustment and a 19V DC Coarse Adjustment. The "Fine" adjustment is normally performed to calibrate the 3466A. The "Coarse" adjustment is only performed if U600, CR600, or associated components are replaced or if the "Fine" adjustment is out of range.

**5-29. Equipment Required.** The DC Standard (Systron Donner Model M107).

**5-30. 19V DC Fine Adjustment Procedure.** The following procedure calibrates the 3466A's dc volts function. Do the following:

- a. Set the 3466A to the dc volts function and the 20V range.
- b. Set the DC Standard for a +19.000V output.
- c. Connect the DC Standard to the 3466A's V and COM input terminals as shown in Figure 4-1 (see Section IV).
- d. Adjust R602 for a +19.000V reading on the 3466A display.
- e. If the +19.000V reading is good, disconnect the DC Standard and continue with paragraph 5-32. If unable to adjust to +19.000V, disconnect the DC Standard and continue with the next paragraph (5-31).

**5-31. 19V DC Coarse Adjustment.** Do this procedure only if unable to perform the 19V DC Fine Adjustment or if U600, CR600, or associated circuitry have been replaced. Do the following:

- a. Set R602 fully counterclockwise.
- b. Replace jumpers JM1 through JM5, if previously removed.
- c. Make sure the 3466A is in the dc volts function and the 20V range.
- d. Set the DC Standard for a +19.000V output and connect it to the 3466A V and COM input terminals.
- e. Note the reading on the 3466A and then refer to Table 5-3 (19V DC Coarse Adjustment).
- f. Locate the reading noted in the previous step in the "3466A Reading" column of Table 5-3. Clip out the corresponding jumper(s) as shown in the "Jumper (JM) Configuration" column of the table.
- g. Adjust R602 for a +19.000V reading on the display.
- h. Disconnect the DC Standard.

**5-32. 2V DC Zero Offset Adjustment (R118\*/R120\*)**

5-33. Do this adjustment if the Input Hybrid (U102) has been replaced. Do the following:

**NOTE**

*The 2V DC Offset Adjustment may not be necessary if the Input Hybrid (U102) has not been replaced.*

- a. Set the 3466A to the dc volts function and the 2V range.
- b. Connect a short across the V and COM input terminals.
- c. Note the reading on the 3466A display. If the reading is .0000V, continue with paragraph 5-34. If not, continue with step d.
- d. Turn the 3466A off and remove R118\* and/or R120\*, if installed.

**NOTE**

*R118\* and R120\* are factory selected components and may not be installed in the Multimeter (A1 assembly).*

**Table 5-3. 19V DC Coarse Adjustment**

3466A Reading	Jumper (JM) Configuration				
	1	2	3	4	5
16.900 to 17.010	0	0	0	0	0
17.011 to 17.066	0	0	0	0	1
17.067 to 17.124	0	0	0	1	0
17.125 to 17.182	0	0	0	1	1
17.183 to 17.240	0	0	1	0	0
17.241 to 17.292	0	0	1	0	1
17.293 to 17.360	0	0	1	1	0
17.361 to 17.419	0	0	1	1	1
17.420 to 17.479	0	1	0	0	0
17.480 to 17.539	0	1	0	0	1
17.540 to 17.600	0	1	0	1	0
17.601 to 17.663	0	1	0	1	1
17.664 to 17.724	0	1	1	0	0
17.725 to 17.787	0	1	1	0	1
17.788 to 17.850	0	1	1	1	0*
17.851 to 17.913	0	1	1	1	1
17.914 to 17.977	1	0	0	0	0
17.978 to 18.041	1	0	0	0	1
18.042 to 18.105	1	0	0	1	0
18.106 to 18.172	1	0	0	1	1
18.173 to 18.236	1	0	1	0	0
18.237 to 18.303	1	0	1	0	1
18.303 to 18.370	1	0	1	1	0
18.371 to 18.437	1	0	1	1	1
18.438 to 18.503	1	1	0	0	0
18.504 to 18.572	1	1	0	0	1
18.573 to 18.640	1	1	0	1	0
18.641 to 18.709	1	1	0	1	1
18.710 to 18.779	1	1	1	0	0
18.780 to 18.840	1	1	1	0	1
18.841 to 18.919	1	1	1	1	0
18.920 to 19.000	1	1	1	1	1

1 = Jumper In (Shorted)  
0 = Jumper Out (Open)

\*Example:  
If the reading in 5-31-e is 17.790, the jumper configuration is 01110.

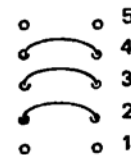

- e. With the Multimeter input shorted and set to the 2V range, note the reading on the display again.
- f. Refer to Table 5-4 and select the appropriate R118\* and R120\* resistors to bring the 3466A reading to .0000V.
- g. Once the new values of R118\* and R120\* are installed, repeat steps a, b, and c.

Table 5-4. R118\* and R120\* Selection

3466A Reading	R118*	R120*	hp Part Number
$\geq +.0002$	93.1k	open	0698-4525
$= +.0001$	187k	open	0698-0077
$= -.0001$	open	187k	0698-0077
$\geq -.0002$	open	93.1k	0698-4525

**5-34. (8) Zero Input DC Adjustment (R134)****5-35. Adjustment Procedure.** Do the following:

- Set the 3466A to the dc volts function and the 20mV range.
- Connect a short across the V and COM input terminals.
- Adjust R134 (on rear panel) for a 0.000mV reading on the display.

**5-36. (9) 19V AC 200Hz and (10) 1.9V AC 200Hz Adjustments (R303 and R302)****5-37. Equipment Required.** The AC Calibrator (Fluke Model 5200A).**5-38. Adjustment Procedure.** The following procedure calibrates the 3466A's ac volts function. Do the following:

- Set the 3466A to the ac volts function and the 20V range.
- Set the AC Calibrator for a 19.000V, 200Hz output and connect it to the 3466A V and COM input terminals, as shown in Figure 4-2 (see Section IV).
- Adjust R303 for a 19.000V reading on the 3466A display.
- Change the AC Calibrator output to 1.9V, 200Hz.
- Adjust R302 for a 1.900V reading on the 3466A display.
- Repeat steps b through e until both the 19V and 1.9V readings are correct. This is necessary since R303 and R302 are interactive with each other.
- Disconnect the AC Calibrator from the 3466A.

**5-39. (10) A and (10) B True RMS Converter Adjustments (R308/R309)**

5-40. Perform these adjustment only if the A5 assembly is installed in the 3466A in place of U300. The A4 assembly must be removed from the Multimeter and reconnected to the A1 assembly using the Service Cable (03466-61601), to do the adjustments.

**5-41. Equipment Required.** The DC Standard (Systron Donner Model M107).**5-42. Adjustment Procedure.** The following adjustment procedure is only used to adjust the A5 assembly. Do the following:

- Locate and then center R308 and R309.
- Set the 3466A to the dc + ac volts function and the 20V range.
- Set the DC Standard for a +1.9000V dc output and connect it to the 3466A's V and COM input terminals.
- Note the reading on the 3466A display.
- Reverse the polarity on the DC Standard.
- Adjust R308 for a display reading previously noted in step d.
- Change the DC Standard output to +19.000V dc.
- Note the reading on the 3466A display.
- Reverse the polarity on the DC Standard.
- Adjust R309 for a display reading previously noted in step h ( $\pm 5$  counts).
- Repeat steps b through i until both R308 and R309 adjustments are correct.
- Disconnect the DC Standard from the 3466A. Then do the ac volts adjustments in paragraph 5-36 before continuing with the next paragraph.

**5-43. (11) 19V AC 10kHz and (12) 1.9V AC 10kHz Adjustments (R102 and C102)****5-44. Equipment Required.** The AC Calibrator (Fluke Model 5200A).**5-45. Adjustment Procedure.** The following procedure calibrates the 3466A's ac volts function at 10kHz. Do the following:

- Set the 3466A to the ac volts function and the 20V range.
- Set the AC Calibrator for a 19.000V, 10kHz output and connect it to the 3466A V and COM input terminals, as shown in Figure 4-2 (see Section IV).
- Adjust R102 for a 19.000V reading on the 3466A display.
- Set the 3466A to the 2V range.
- Change the AC Calibrator output to 1.9V, 10kHz.

f. Adjust C102 for a 1.9000V reading on the 3466A display.

g. Leave the AC Calibrator connected for the next adjustment.

**5-46. 13 100kHz Frequency Response Adjustment (C202)**

**5-47. Equipment Required.** The AC Calibrator (Fluke Model 5200A).

**5-48. Adjustment Procedure.** The following procedure adjusts the high frequency response of the 3466A. Do the following:

a. Set the 3466A to the ac volts function and the 2V range.

b. Set the AC Calibrator for a 1.9000V, 10kHz output and connect it to the 3466A V and COM input terminals, as shown in Figure 4-2 (see Section IV).

c. Note the reading on the 3466A display.

d. Set the 3466A to the 20V range.

e. Change the AC Calibrator output to 19V, 100kHz.

f. Adjust C202 for a display reading previously noted in step h (adjust to the numerical value of the reading and ignore decimal point placement).

g. Repeat steps a through f until the numerical values of the readings are the same without adjusting C202.

h. Disconnect the AC Calibrator from the 3466A.

**5-49. 1A DC Adjustment (R660)**

**5-50. Equipment Required.** The following equipment is required to do the test.

- Digital Multimeter (-hp- Model 3468A)
- DC Power Supply (-hp- Model 6294A)
- Resistor 1 ohm  $\pm 0.02\%$   
(General Radio No. 1440-9601)

**5-51. Adjustment Procedure.** The following procedure adjusts the 3466A's current function. Do the following:

a. Connect the 3466A to the DC Power Supply and test Digital Multimeter as shown in Figure 4-4 (see Section IV).

b. Connect the 1 ohm  $\pm 0.02\%$  resistor in the Ra position as shown in Figure 4-4.

c. Set the 3466A to the dcA function and the 2000mA range.

d. Set the output of the DC Power Supply for a 1.00000V reading on the test digital multimeter.

e. Adjust R660 for a 1000.0mA reading on the 3466A display.

f. Remove the test equipment from the 3466A. This completes the adjustment procedures.

**5-52. POWER REQUIREMENT MODIFICATION INSTRUCTIONS**

5-53. The 3466A can be configured for four different ac power line voltages: 86-106V, 104-127V, 190-233V, and 208-250V. This is accomplished by arranging resistors R721 through R725 as shown in Figure 5-1. The resistors are 2.7 ohms each which can also be substituted by jumper wires (i.e., shorts).

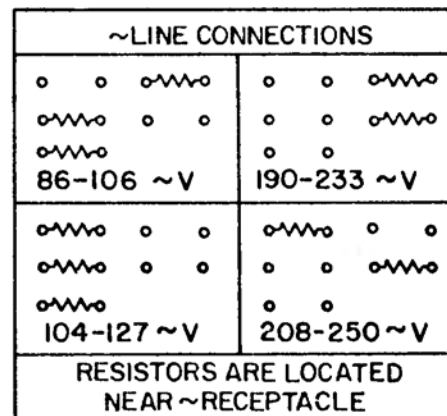
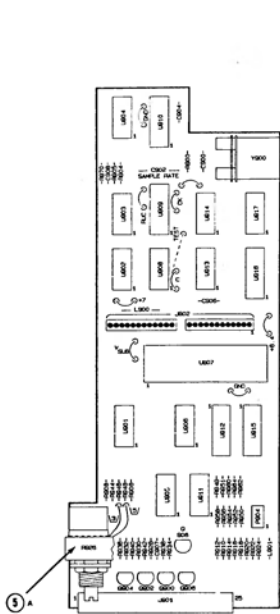
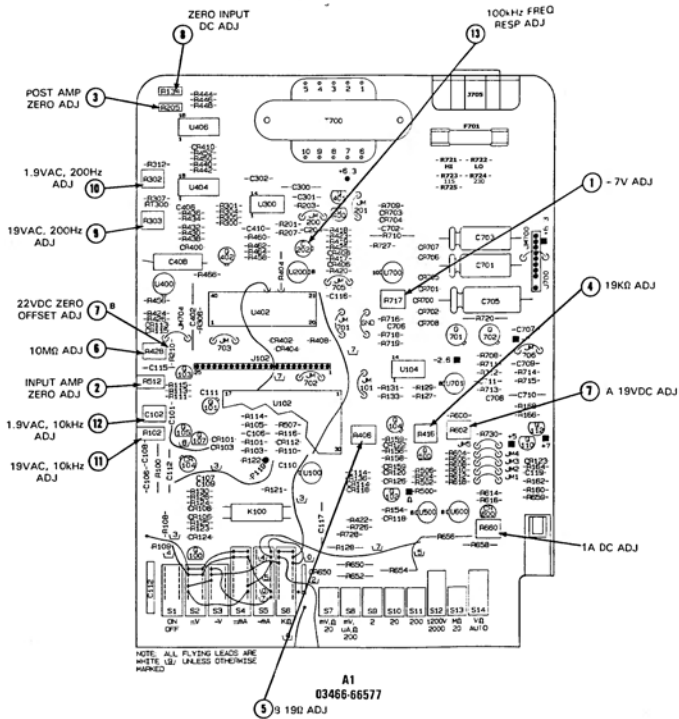

Figure 5-1. Line Voltage Configuration



**A4**  
03466-66514



**A1**  
03466-66577

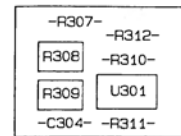

**A5**  
03466-66505

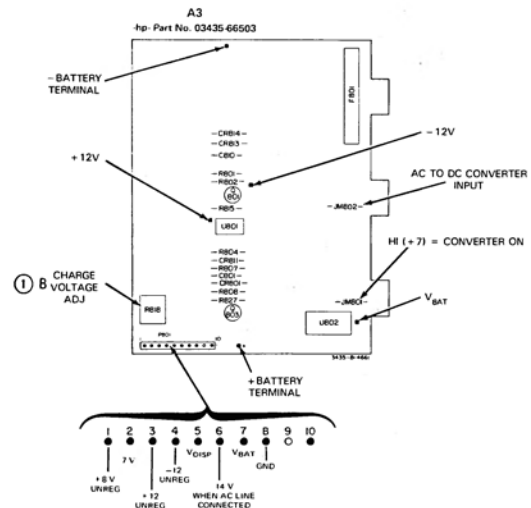

Figure 5-2. Adjustment Locator  
5-7/5-8

# SECTION VI

## REPLACEABLE PARTS

### 6-1. INTRODUCTION

6-2. This section contains information for ordering replacement parts. Table 6-3 lists parts in alphameric order of their reference designators and indicates the description, -hp- Part Number of each part, together with any applicable notes, and provides the following:

- Total quantity used in the instrument (Qty column). The total quantity of a part is given the first time the part number appears.
- Description of the part. (See list of abbreviations in Table 6-1).
- Typical manufacturer of the part is a five-digit code. (See Table 6-2 for list of manufacturers.)
- Manufacturer's part number.

6-3. Miscellaneous parts are listed in Table 6-3 following their respective assemblies. General miscellaneous parts are listed at the conclusion of Table 6-3.

### 6-4. ORDERING INFORMATION

6-5. To obtain replacement parts, address order or

inquiry to your local Hewlett-Packard Field Office. (Appendix A for list of office locations.) Identify parts by their Hewlett-Packard part numbers. Include instrument model and serial numbers.

### 6-6. NON-LISTED PARTS

6-7. To obtain a part that is not listed, include:

- Instrument model number.
- Instrument serial number.
- Description of the part.
- Function and location of the part.

### 6-8. PARTS CHANGES

6-9. Components which have been changed are so marked by one of three symbols; i.e.,  $\Delta$ ,  $\Delta$  with a letter subscript, e.g.,  $\Delta_a$ , or  $\Delta$  with a number suscription, e.g.,  $\Delta_{10}$ . A  $\Delta$  with no subscript indicates the component listed is the preferred replacement for an earlier component. A  $\Delta$  with a letter subscript indicates a change which is explained in a note at the bottom of the page. A  $\Delta$  with a number subscript indicates the related change is discussed in backdating (Section VIII). The number of the subscript indicates the number of the change in backdating which should be referred to.

**Table 6-1. Standard Abbreviations**

ABBREVIATIONS			
Ag .....	silver	Hz .....	hertz (cycles) per second
Al .....	aluminum	NPO .....	negative positive zero (zero temperature coefficient)
A .....	ampere(s)	ns .....	nanosecond(s) = 10 <sup>-9</sup> seconds
Au .....	gold	nsr .....	not separately replaceable
C .....	capacitor	$\Omega$ .....	ohm(s)
cer .....	ceramic	obd .....	order by description
coef .....	coefficient	DO .....	outside diameter
com .....	common	p .....	peak
comp .....	composition	pA .....	picoampere(s)
conn .....	connection	pc .....	printed circuit
dep .....	deposited	pF .....	picofarad(s) 10 <sup>-12</sup> farads
DPDT .....	double-pole double-throw	piv .....	peak inverse voltage
DPST .....	double pole single throw	p/o .....	part of
elect .....	electrolytic	pos .....	position(s)
encap .....	encapsulated	poly .....	polystyrene
F .....	farad(s)	pot .....	potentiometer
FET .....	field effect transistor	p-p .....	peak-to-peak
fixd .....	fixed	ppm .....	parts per million
GaAs .....	gallium arsenide	prec .....	precision temperature coefficient, long term stability and/or tolerance
GHz .....	gigahertz = 10 <sup>9</sup> hertz	R .....	resistor
gd .....	guard(ed)	Rh .....	rhodium
Ge .....	germanium	rms .....	root-mean-square
gnd .....	ground(ed)	rot .....	rotary
H .....	henry(ies)	Se .....	selenium
Hg .....	mercury	sect .....	section(s)
		Si .....	silicon
DESIGNATORS			
A .....	assembly	FL .....	filter
B .....	motor	O .....	transistor
BT .....	battery	HR .....	heater
C .....	capacitor	IC .....	integrated circuit
CR .....	diode	J .....	jack
DL .....	delay line	K .....	relay
DS .....	lamp	L .....	inductor
E .....	misc electronic part	M .....	meter
F .....	fuse	MP .....	mechanical part
		P .....	plug
sl .....	slide	TS .....	terminal strip
SPDT .....	single-pole double throw	U .....	microcircuit
SPST .....	single pole single throw	V .....	vacuum tube, neon bulb, photocell, etc
Ta .....	tantalum	W .....	cable
TC .....	temperature coefficient	X .....	socket
TiO <sub>2</sub> .....	titanium dioxide	XDS .....	lampholder
tog .....	toggle	XF .....	fuseholder
tol .....	tolerance	Y .....	crystal
trim .....	trimmer	Z .....	network
TSTR .....	transistor		
V .....	volt(s)		
vacw .....	alternating current working voltage		
var .....	variable		
wdcw .....	direct current working voltage		
W .....	watt(s)		
w/ .....	with		
wiv .....	working inverse voltage		
w/o .....	without		
ww .....	wirewound		
		* .....	optimum value selected at factory.
		** .....	average value shown (part may be omitted) no standard type number assigned selected or special type
		(R) .....	Dupont de Nemours

**6-10. PROPRIETARY PARTS**

6-11. Items marked by a dagger (†) in the reference designator column are available only for repair and service of Hewlett-Packard instruments.

**Table 6-2. Code List of Manufacturers**

Mfr No.	Manufacturers Name	Address
01121	Allen-Bradley Co.	Milwaukee, WI 53204
01295	Texas Instr Inc Semicond Cmpnt Div	Dallas, TX 75222
03888	K D I Pyrofilm Corp	Whippany, NJ 07981
04713	Motorola Semiconductor Products	Phoenix, AZ 85008
17856	Siliconix Inc	Santa Clara, CA 95054
19701	Mepco/Electra Corp	Mineral Wells, TX 76067
24546	Corning Glass Works (Bradford)	Bradford, PA 16701
26654	Varadyne Inc	Santa Monica, CA 90404
27014	National Semiconductor Corp	Santa Clara, CA 95051
28480	Hewlett-Packard Co Corporate Hq	Palo Alto, CA 94304
3L585	RCA Corp Solid State Div	Somerville, NJ
32997	Bourns Inc Trimpot Prod Div	Riverside, CA 92507
56289	Sprague Electric Co	North Adams, MA 01247
72136	Electro Motive Corp	Florence, SC 06226
74970	Johnson E F Co	Waseca, MN 56093
75042	TRW Inc Philadelphia Div	Philadelphia, PA 19108
75915	Littelfuse, Inc	Des Plaines, IL 60016
84411	TRW Capacitor Div	Ogallala, NE 69153
95275	Vitramon Inc	Bridgeport, CT 06601
98291	Sealectro Corp	Mamaroneck, NY 10544



Table 6-3. Replaceable Parts

Reference Designation	HP Part Number	C D	Qty	Description	Mfr Code	Mfr Part Number
A1	03466-66577	B	1	PC ASSEMBLY: MOTHER	28400	03466-66577
	04366-66516	6	1	PC ASSEMBLY: MOTHER (1716A01831 TO 1716A11460)	28400	04366-66516
	03466-66501	B	1	PC ASSEMBLY: MOTHER (1716A01830 AND BELOW)	28400	03466-66501
A1C100	0160-4602	6	1	CAPACITOR-FXD .1UF +-10% 630VDC	28400	0160-4602
A1C101	0160-4961	0	1	CAPACITOR FXD 350PF50VDC CER	28400	0160-4961
A1C102	0121-0127	0	1	CAPACITOR-V TRMR-AIR 2.1-13.3PF 350V	74970	1R9-0505-020
A1C105	0100-1735	2	1	CAPACITOR-FXD .22UF+-10% 35VDC TA	56209	150D224X9035A2
A1C106	0160-4942	7	1	CAPACITOR-FXD 39PF +-2% 2KVAC(RMS) PORC	95275	VY81C390C
A1C107	0160-3622	B	3	CAPACITOR-FXD .1UF +80-20% 100VDC CER	26654	2130Y5U100R104Z
A1C108	0160-4310	1	1	CAPACITOR-FXD 330PF +-1% 500VDC MICA	28400	0160-4310
A1C109	0160-3622	B	3	CAPACITOR-FXD .1UF +80-20% 100VDC CER	26654	2130Y5U100R104Z
A1C110	0160-2204	0	2	CAPACITOR-FXD 100PF +-5% 300VDC MICA	28400	0160-2204
A1C111*	0160-0763	2	1	CAPACITOR-FXD 5PF +-10% 500VDC MICA	28400	0160-0763
A1C112	0160-0162	5	1	CAPACITOR-FXD .022UF +-10% 200VDC POLYE	28400	0160-0162
A1C114	0160-4801	7	1	CAPACITOR-FXD 100PF +-5% 100VDC CER	28400	0160-4801
A1C115	0180-0229	7	1	CAPACITOR-FXD 33UF+-10% 10VDC TA	56289	150D336X9010B2
A1C116	0160-3847	9	6	CAPACITOR-FXD .01UF +100-0% 50VDC CER	28400	0160-3847
A1C117	0160-5141	0	1	CAPACITOR-FXD .015UF +-20% 2KVDC	28400	0160-5141
A1C119	0150-0012	3	1	CAPACITOR-FXD .01UF +-20% 1KVDC CER	56289	C023A102J103M53B
A1C202	0121-0451	3	1	CAPACITOR-V TRMR-AIR 1.7-11PF 175V	74970	187-0106-028
A1C204	0160-2263	1	1	CAPACITOR-FXD 10PF 500V	20480	0160-2263
A1C300	0180-0100	3	1	CAPACITOR-FXD 4.7UF+-10% 35VDC TA	56209	150D475X9035B2
A1C301	0100-0291	3	6	CAPACITOR FXD 1UF+-10% 35VDC TA	56289	1500105X9035A2
A1C302	0180-0291	3	1	CAPACITOR-FXD 1UF+-10% 35VDC TA	56289	1500105X9035A2
A1C402	0160-4936	9	1	CAPACITOR-FXD .1UF +-10% 200VDC POLYP	28400	0160-4936
A1C406	0160-2199	2	1	CAPACITOR-FXD 30PF +-5% 300VDC MICA	28400	0160-2199
A1C400	0160-0320	7	1	CAPACITOR-FXD .33UF +-10% 100VDC POLYE	84411	663UW33491W
A1C410	0180-0210	6	1	CAPACITOR-FXD 3.3UF+-20% 15VDC TA	56289	150D335X0015A2
A1C700	0160-2055	9	1	CAPACITOR-FXD .01UF +80-20% 100VDC CER	28400	0160-2055
A1C701	0180-2651	3	1	CAPACITOR-FXD 470UF+75-10% 16VDC AL	56209	500D470H016DF7
A1C702	0160-3047	9	1	CAPACITOR-FXD .01UF +100-0% 50VDC CER	28400	0160-3047
A1C703	0180-2630	6	1	CAPACITOR-FXD 220UF+75-10% 35VDC AL	56289	500D227H035DF7
A1C705	0100-2506	7	1	CAPACITOR FXD 470UF+50-10% 25VDC AL	28400	0100-2506
A1C706	0140-0198	5	1	CAPACITOR-FXD 200PF +-5% 300VDC MICA	72136	DM1G201J0300WV1CR
A1C707	0180-0291	3	1	CAPACITOR-FXD 1UF+-10% 35VDC TA	56289	150D105X9035A2
A1C708	0160-2200	4	1	CAPACITOR-FXD 330PF +-5% 300VDC MICA	28400	0160-2200
A1C709	0180-0291	3	1	CAPACITOR-FXD 1UF+-10% 35VDC TA	56209	150D105X9035A2
A1C710	0180-0220	6	1	CAPACITOR-FXD 22UF+-10% 15VDC TA	56209	150D226X9015B2
A1C711	0180-0291	3	1	CAPACITOR-FXD 1UF+-10% 35VDC TA	56289	1500105X9035A2
A1CR101	1901-0376	6	4	DIODE-GEN PRP 35V 50MA DO-35	28400	1901-0376
A1CR103	1901-0376	6	1	DIODE-GEN PRP 35V 50MA DO-35	28400	1901-0376
A1CR104	1906-0100	4	1	DIODE DUAL 35V 50MA	17056	DPAD 100
A1CR106	1901-0040	1	23	DIODE-SWITCHING 30V 50MA 2NS DO-35	28400	1901-0040
A1CR108	1901-0040	1	1	DIODE-SWITCHING 30V 50MA 2NS DO-35	20480	1901-0040
A1CR110	1901-0376	6	1	DIODE-GEN PRP 35V 50MA DO-35	28400	1901-0376
A1CR112	1901-0376	6	1	DIODE-GEN PRP 35V 50MA DO-35	28400	1901-0376
A1CR113	1901-0040	1	1	DIODE-SWITCHING 30V 50MA 2NS DO-35	28400	1901-0040
A1CR114	1901-0040	1	1	DIODE-SWITCHING 30V 50MA 2NS DO-35	28400	1901-0040
A1CR115	1901-0040	1	1	DIODE-SWITCHING 30V 50MA 2NS DO-35	28400	1901-0040
A1CR116	1901-0040	1	1	DIODE-SWITCHING 30V 50MA 2NS DO-35	20480	1901-0040
A1CR118	1902-0049	2	1	DIODE-ZNR 6.19V 5% DO-35 PD=.4W	28400	1902-0049
A1CR120	1901-0040	1	1	DIODE-SWITCHING 30V 50MA 2NS DO-35	28400	1901-0040
A1CR122	1901-0029	6	7	DIODE-PWR RECT 600V 750MA DO-29	28400	1901-0029
A1CR123	1901-0040	1	1	DIODE-SWITCHING 30V 50MA 2NS DO-35	20480	1901-0040
A1CR124	1901-0040	1	1	DIODE-SWITCHING 30V 50MA 2NS DO-35	28400	1901-0040
A1CR126	1902-3171	7	3	DIODE-ZNR 11V 5% DO-35 PD=.4W TC=+.062%	28400	1902-3171
A1CR139	1901-0040	1	1	DIODE-SWITCHING 30V 50MA 2NS DO-35	28400	1901-0040
A1CR400	1901-0040	1	1	DIODE-SWITCHING 30V 50MA 2NS DO-35	28400	1901-0040
A1CR402	1901-0040	1	1	DIODE-SWITCHING 30V 50MA 2NS DO-35	28400	1901-0040
A1CR404	1901-0040	1	1	DIODE-SWITCHING 30V 50MA 2NS DO-35	28400	1901-0040
A1CR406	1902-3171	7	1	DIODE-ZNR 11V 5% DO-35 PD=.4W TC=+.062%	28400	1902-3171
A1CR408	1902-3171	7	1	DIODE-ZNR 11V 5% DO-35 PD=.4W TC=+.062%	20480	1902-3171
A1CR410	1901-0040	1	1	DIODE-SWITCHING 30V 50MA 2NS DO-35	28400	1901-0040
A1CR600	1902-0928	6	1	DIODE-ZNR 6.9V 4% TO-92 TC=+.002%	27014	LM329
A1CR650	1906-0096	7	1	DIODE-FW BRDC 200V 2A	04713	MBA202
A1CR701	1901-0029	6	1	DIODE-PWR RECT 600V 750MA DO-29	28400	1901-0029
A1CR702	1901-0029	6	1	DIODE-PWR RECT 600V 750MA DO-29	28400	1901-0029
A1CR703	1901-0029	6	1	DIODE-PWR RECT 600V 750MA DO-29	28400	1901-0029
A1CR704	1901-0029	6	1	DIODE-PWR RECT 600V 750MA DO-29	28400	1901-0029

See introduction to this section for ordering information  
\*Indicates factory selected value

Table 6-3. Replaceable Parts (Cont'd)

Reference Designation	HP Part Number	C D	Qty	Description	Mfr Code	Mfr Part Number
A1CR705	1901-0029	6	2	DIODE-PWR RECT 600V 750MA DD-29	20400	1901-0029
A1CR706	1901-0029	6		DIODE-PWR RECT 600V 750MA DD-29	20400	1901-0029
A1CR707	1901-0050	3		DIODE-SWITCHING 80V 200MA 2NS DD-35	20400	1901-0050
A1CR708	1901-0050	3		DIODE-SWITCHING 80V 200MA 2NS DD-35	20400	1901-0050
A1F701	2110-0318	0	1	FUSE .125A 250V TD 1.25X.25 UL	20400	2110-0318
A1J102	1251-4920	5	1	CONNECTOR 25-PIN F POST TYPE	20400	1251-4920
A1J700	1251-4401	7	2	CONNECTOR 10-PIN M POST TYPE	20400	1251-4401
A1J705	1251-4743	0	1	CONNECTOR-AC PWR HP-9 MALE REC-FLG THRM P	20400	1251-4743
A1K100	0490-1247	8	1	RELAY-REED 1A 1A 200VDC 6VDC-COIL 2VA	20400	0490-1247
A1Q100	1854-0071	7	6	TRANSISTOR NPN SI PD=300MW FT=200MHZ	20400	1854-0071
A1Q101	1855-0469	9	1	TRANSISTOR-JFET DUAL N-CHAN TO-71	20400	1855-0469
A1Q102	1853-0086	2	3	TRANSISTOR PNP SI PD=310MW FT=40MHZ	27014	2N5087
A1Q103	1854-0071	7	1	TRANSISTOR NPN SI PD=300MW FT=200MHZ	20400	1854-0071
A1Q104	1854-0079	5	1	TRANSISTOR NPN 2N3439 SI TO-5 PD=1W	3L505	2N3439
A1Q105	1855-0270	0	2	TRANSISTOR J FET N-CHAN D MODE TO-92 SI	20400	1855-0270
A1Q107	1855-0270	0	0	TRANSISTOR J-FET N-CHAN D-MODE TO-92 SI	20400	1855-0270
A1Q110	1854-0071	7	1	TRANSISTOR NPN SI PD=300MW FT=200MHZ	20400	1854-0071
A1Q112	1854-0071	7	1	TRANSISTOR NPN SI PD=300MW FT=200MHZ	20400	1854-0071
A1Q400	1853-0086	2	1	TRANSISTOR PNP SI PD=310MW FT=40MHZ	27014	2N5087
A1Q401	1853-0086	2	1	TRANSISTOR PNP SI PD=310MW FT=40MHZ	27014	2N5087
A1Q402	1855-0308	5	1	TRANSISTOR-JFET DUAL N-CHAN D-MODE SI	20400	1855-0308
A1Q500	1854-0071	7	1	TRANSISTOR NPN SI PD=300MW FT=200MHZ	20400	1854-0071
A1Q701	1854-0039	7	1	TRANSISTOR NPN 2N3053S SI TO-39 PD=1W	3L585	2N3053S
A1Q702	1853-0012	4	1	TRANSISTOR PNP 2N2904A SI TO-39 PD=600MW	01295	2N2904A
A1R100	0698-8951	5	1	RESISTOR 1.0M .5X 1W F TC=0+-25	20400	0698-8951
A1R101	0698-4495	4	3	RESISTOR 37.4K 1X .125W F TC=0+-100	24546	C4-1/8-T0-3742-F
A1R102	2100-3659	7	1	RESISTOR-TRMR 20K 10X C TOP-ADJ 17-TRN	32997	3292W-1-203
A1R103	0698-4495	4	1	RESISTOR 37.4K 1X .125W F TC=0+-100	24546	C4-1/8-T0-3742-F
A1R105	0757-0420	3	1	RESISTOR 750 1X .125W F TC=0+-100	24546	C4-1/8-T0-751-F
A1R108	0698-3279	0	4	RESISTOR 4.99K 1X .125W F TC=0+-100	24546	C4-1/8-T0-4991-F
A1R109	0683-1005	5	2	RESISTOR 10 5X .25W FC TC=-400/+500	01121	CB1005
A1R111	0698-4495	4	1	RESISTOR 37.4K 1X .125W F TC=0+-100	24546	C4-1/8-T0-3742-F
A1R113	0698-4500	2	1	RESISTOR 57.6K 1X .125W F TC=0+-100	24546	C4-1/8-T0-5762-F
A1R114	0683-1065	7	1	RESISTOR 10M 5X .25W CC TC=-900/+1100	01121	CB1065
A1R115	0698-4504	6	1	RESISTOR 69.0K 1X .125W F TC=0+-100	24546	C4-1/8-T0-6902-F
A1R116	0683-0275	9	8	RESISTOR 2.7 5X .25W FC TC=-400/+500	01121	CB27G5
A1R118*	0698-0077	0	2	RESISTOR 93.1K 1X .125W F TC=0+-100	03000	PM55-1/0-T0-9312-F
A1R118*	0698-1525	5	2	RESISTOR: FIXED 187K .04 1/0W	20400	0698-1525
A1R119*	0698-4123	5	3	RESISTOR 499 1X .125W F TC=0+-100	24546	C4-1/8-T0-499R-F
A1R119*	0698-4435	2	1	RESISTOR 2.49K 1X .125W F TC=0+-100	24546	C4-1/8-T0-2491-F
A1R119*	0757-0273	4	1	RESISTOR 3.01K 1X .125W F TC=0+-100	24546	C4-1/8-T0-3011-F
A1R119*	0757-0280	3	1	RESISTOR 1K 1X .125W F TC=0+-100	24546	C4-1/8-T0-1001-F
A1R119*	0757-0203	6	7	RESISTOR 2K 1X .125W F TC=0+-100	24546	C4-1/8-T0-2001-F
A1R119*	0757-0427	0	1	RESISTOR 1.5K 1X .125W F TC=0+-100	24546	C4-1/8-T0-1501-F
A1R119*	0757-0430	5	1	RESISTOR 2.21K 1X .125W F TC=0+-100	24546	C4-1/8-T0-2211-F
A1R120*	0698-0077	0	3	RESISTOR 93.1K 1X .125W F TC=0+-100	03000	PM55-1/0-T0-9312-F
A1R120*	0698-1525	5	3	RESISTOR: FIXED 187K .04 1/0W	20400	0698-1525
A1R121	0683-1025	3	1	RESISTOR 1.8K 5X .5W CC TC=0/+647	01121	CB1025
A1R122	0693-1041	0	1	RESISTOR 100K 10X 2W CC TC=0/+082	01121	CB1041
A1R123	0683-1045	3	6	RESISTOR 100K 5X .25W FC TC=-400/+000	01121	CB1045
A1R124	0683-4735	4	10	RESISTOR 47K 5X .25W FC TC=-400/+800	01121	CB4735
A1R125	0683-4735	4	1	RESISTOR 47K 5X .25W FC TC=-400/+800	01121	CB4735
A1R126	0683-4735	4	1	RESISTOR 47K 5X .25W FC TC=-400/+800	01121	CB4735
A1R127	0683-4735	4	1	RESISTOR 47K 5X .25W FC TC=-400/+800	01121	CB4735
A1R128	0811-1858	9	1	RESISTOR 500 5X 5W PW TC=0+-20	20400	0811-1858
A1R129	0683-4735	4	1	RESISTOR 47K 5X .25W FC TC=-400/+800	01121	CB4735
A1R130	0683-0275	9	1	RESISTOR 2.7 5X .25W FC TC=-400/+500	01121	CB27G5
A1R131	0698-4470	5	3	RESISTOR 6.98K 1X .125W F TC=0+-100	24546	C4-1/8-T0-6981-F
A1R132	0683-6245	5	1	RESISTOR 620K 5X .25W FC TC=-800/+900	01121	CB6245
A1R133	0698-4470	5	1	RESISTOR 6.98K 1X .125W F TC=0+-100	24546	C4-1/8-T0-6981-F
A1R134	2100-3356	1	1	RESISTOR-TRMR 200K 10X C SIDE-ADJ 1-TRN	20400	2100-3356
A1R136	0683-1025	9	1	RESISTOR 1K 5X .25W FC TC=-400/+600	01121	CB1025
A1R152	2100-3003	1	1	RESISTOR-TRMR 500 10X C 10P-ADJ 17-TRN	32997	3292W-1-501
A1R154	0757-0449	6	3	RESISTOR 20K 1X .125W F TC=0+-100	24546	C4-1/8-T0-2002-F
A1R156	0683-4725	2	8	RESISTOR 4.7K 5X .25W FC TC=-400/+700	01121	CB4725
A1R158	0698-8767	1	1	RESISTOR 200K 5X .25W CC TC=-800/+900	20400	0698-8767
A1R159	0698-8768	2	2	RESISTOR 100 5X .25W CC TC=-400/+500	20400	0698-8768
A1R160	0683-4725	2	1	RESISTOR 4.7K 5X .25W FC TC=-400/+700	01121	CB4725
A1R162	0683-2045	5	2	RESISTOR 200K 5X .25W FC TC=-800/+900	01121	CB2045
A1R164	0683-2045	5	1	RESISTOR 200K 5X .25W FC TC=-800/+900	01121	CB2045
A1R166	0683-4735	4	1	RESISTOR 47K 5X .25W FC TC=-400/+800	01121	CB4735
A1R168	0683-4735	4	1	RESISTOR 47K 5X .25W FC TC=-400/+800	01121	CB4735
A1R201	0757-0401	0	1	RESISTOR 100 1X .125W F TC=0+-100	24546	C4-1/8-T0-101-F
A1R203	0698-3458	7	1	RESISTOR 348K 1X .125W F TC=0+-100	20400	0698-3458

See introduction to this section for ordering information  
\*Indicates factory selected value

Table 6-3. Replaceable Parts (Cont'd)

Reference Designation	HP Part Number	C D	Qty	Description	Mfr Code	Mfr Part Number
A1R205	2100-3670	0	1	RESISTOR-TRMR 500K 10% C TOP-ADJ 17-TRN	20400	2100-3670
A1R207	0757-0288	1	1	RESISTOR 9.09K 1% .125W F TC=0+-100	19701	HF4C1/8-T0-9891-F
A1R300	0670-3437	2	1	RESISTOR 133 1% .125W F TC=0+-100	24546	C4-1/8-T0-133R-F
A1R301	0757-0271	2	1	RESISTOR 124K 1% .125W F TC=0+-100	24546	C4-1/8-T0-1243-F
A1R302	2100-0500	7	1	RESISTOR-TRMR 500K 10% C TOP-ADJ 1-TRN	20400	2100-0500
A1R303	2100-3210	0	2	RESISTOR-TRMR 10K 10% C TOP-ADJ 1-TRN	20400	2100-3210
A1R304	0683-2735	6	4	RESISTOR 27K 5% .25W FC TC=-400/+800	01121	CB2735
A1R305	0757-0471	4	1	RESISTOR 182K 1% .125W F TC=0+-100	24546	C4-1/8-T0-1823-F
A1R306	0690-4522	8	1	RESISTOR 165K 1% .125W F TC=0+-100	24546	C4-1/8-T0-1653-F
A1R307	0698-3226	7	1	RESISTOR 6.49K 1% .125W F TC=0+-100	24546	C4-1/8-T0-6491-F
A1R404	0698-0954	8	1	RESISTOR 500K .1% .125W F TC=0+-10	20400	0698-0954
A1R406	2100-3211	7	1	RESISTOR-TRMR 1K 10% C TOP-ADJ 1-TRN	20400	2100-3211
A1R408	0698-8953	7	1	RESISTOR 49.2K 1% .125W F TC=0+-10	20400	0698-8953
A1R416	2100-3252	6	1	RESISTOR-TRMR 5K 10% C TOP-ADJ 1-TRN	20400	2100-3252
A1R417	0757-0451	0	1	RESISTOR 24.3K 1% .125W F TC=0+-100	24546	C4-1/8-T0-2432-F
A1R418	0683-4735	4	4	RESISTOR 47K 5% .25W FC TC=-400/+800	01121	CB4735
A1R419	0690-3260	7	2	RESISTOR 11.5K 1% .125W F TC=0+-100	24546	C4-1/8-T0-1152-F
A1R420	0683-4735	4	4	RESISTOR 47K 5% .25W FC TC=-400/+800	01121	CB4735
A1R422	0757-0277	0	1	RESISTOR 49.9 1% .125W F TC=0+-100	24546	C4-1/8-T0-4992-F
A1R423	0683-1055	5	4	RESISTOR 1M 5% .25W FC TC=-800/+900	01121	CB1055
A1R424	0757-0410	1	1	RESISTOR 301 1% .125W F TC=0+-100	24546	C4-1/8-T0-301R-F
A1R425	0698-4470	5	1	RESISTOR 6.90K 1% .125W F TC=0+-100	24546	C4-1/8-T0-6901-F
A1R426	0757-0472	5	2	RESISTOR 200K 1% .125W F TC=0+-100	24546	C4-1/8-T0-2003-F
A1R428	2100-3214	0	1	RESISTOR-TRMR 100K 10% C TOP-ADJ 1-TRN	20400	2100-3214
A1R430	0683-4725	2	2	RESISTOR 4.7K 5% .25W FC TC=-400/+700	01121	CB4725
A1R432	0603-2735	0	8	RESISTOR 27K 5% .25W FC TC=-400/+800	01121	CB2735
A1R434	0603-2735	0	8	RESISTOR 27K 5% .25W FC TC=-400/+800	01121	CB2735
A1R436	0698-3220	9	7	RESISTOR 49.9K 1% .125W F TC=0+-100	20400	0698-3220
A1R438	0698-4123	5	2	RESISTOR 499 1% .125W F TC=0+-100	24546	C4-1/8-T0-499R-F
A1R440	0683-4725	2	2	RESISTOR 4.7K 5% .25W FC TC=-400/+700	01121	CB4725
A1R442	0603-2735	0	8	RESISTOR 27K 5% .25W FC TC=-400/+800	01121	CB2735
A1R444	0698-4123	5	1	RESISTOR 499 1% .125W F TC=0+-100	24546	C4-1/8-T0-499R-F
A1R446	0698-3519	1	1	RESISTOR 12.4K 1% .125W F TC=0+-100	24546	C4-1/8-T0-1242-F
A1R448	0757-0442	9	3	RESISTOR 10K 1% .125W F TC=0+-100	24546	C4-1/8-T0-1002-F
A1R450	0757-0450	7	2	RESISTOR 22.1K 1% .125W F TC=0+-100	24546	C4-1/8-T0-2212-F
A1R452	0757-0449	6	1	RESISTOR 20K 1% .125W F TC=0+-100	24546	C4-1/8-T0-2002-F
A1R456	0698-3228	9	1	RESISTOR 49.9K 1% .125W F TC=0+-100	20400	0698-3228
A1R458	0698-3228	9	1	RESISTOR 49.9K 1% .125W F TC=0+-100	20400	0698-3228
A1R460	0698-3220	9	1	RESISTOR 49.9K 1% .125W F TC=0+-100	20400	0698-3220
A1R462	0698-4502	4	2	RESISTOR 64.9K 1% .125W F TC=0+-100	24546	C4-1/8-T0-6492-F
A1R464	0690-3215	4	1	RESISTOR 499K 1% .125W F TC=0+-100	20400	0698-3215
A1R466	0698-4542	2	1	RESISTOR 453K 1% .125W F TC=0+-100	20400	0698-4542
A1R500	0757-0472	5	1	RESISTOR 200K 1% .125W F TC=0+-100	24546	C4-1/8-T0-2003-F
A1R502	0757-0450	9	1	RESISTOR 22.1K 1% .125W F TC=0+-100	24546	C4-1/8-T0-2212-F
A1R504	0690-4409	6	1	RESISTOR 20K 1% .125W F TC=0+-100	24546	C4-1/8-T0-2002-F
A1R506	0683-1055	5	1	RESISTOR 1M 5% .25W FC TC=-800/+900	01121	CB1055
A1R507	0683-4735	4	1	RESISTOR 47K 5% .25W FC TC=-400/+800	01121	CB4735
A1R600	0798-3279	0	4	RESISTOR 4.99K 1% .125W F TC=0+-100	24546	C4-1/8-T0-4991-F
A1R602	2100-0554	5	1	RESISTOR-TRMR 500 10% C TOP-ADJ 1-TRN	20400	2100-0554
A1R604	0698-4419	2	1	RESISTOR 210 1% .125W F TC=0+-100	24546	C4-1/8-T0-210R-F
A1R606	0698-3447	4	1	RESISTOR 422 1% .125W F TC=0+-100	24546	C4-1/8-T0-422R-F
A1R608	0698-4463	6	1	RESISTOR 845 1% .125W F TC=0+-100	03000	PM855-1/8-T0-845R-F
A1R610	0698-4420	3	1	RESISTOR 1.69K 1% .125W F TC=0+-100	24546	C4-1/8-T0-1691-F
A1R612	0757-0433	8	2	RESISTOR 3.32K 1% .125W F TC=0+-100	24546	C4-1/8-T0-3321-F
A1R614	0698-8955	9	1	RESISTOR 13.5K .1% .1W F TC=0+-10	20400	0698-8955
A1R616	0690-3956	0	1	RESISTOR 42.5K .1% .1W F TC=0+-10	20400	0690-3956
A1R618	0757-0444	1	1	RESISTOR 12.1K 1% .125W F TC=0+-100	24546	C4-1/8-T0-1212-F
A1R650	0811-3392	0	1	RESISTOR 900 .03% .125W PWM TC=0+-10	20400	0811-3392
A1R652	0811-3390	0	1	RESISTOR 90 .03% .125W PWM TC=0+-10	20400	0811-3390
A1R654	0811-3391	9	1	RESISTOR 9 .05% .125W PWM TC=0+-10	20400	0811-3391
A1R656	0811-3455	6	1	RESISTOR .9 .1% 4W PW TC=0+-90	20400	0811-3455
A1R658	0811-3435	2	1	RESISTOR .1 .1% 3W PW TC=0+-90	20400	0811-3435
A1R659	0757-0346	2	1	RESISTOR 10 1% .125W F TC=0+-100	24546	C4-1/8-T0-10R0-F
A1R660	2100-3303	4	1	RESISTOR-TRMR 50 10% C TOP-ADJ 1-TRN	20400	2100-3303
A1R708	0698-8768	2	1	RESISTOR 100 5% .25W CC TC=-400/+500	20400	0698-8768
A1R709	0683-4725	2	1	RESISTOR 4.7K 5% .25W FC TC=-400/+700	01121	CB4725
A1R710	0698-3332	6	1	RESISTOR 80.6 1% .5W F TC=0+-100	20400	0698-3332
A1R711	0757-0442	9	1	RESISTOR 10K 1% .125W F TC=0+-100	24546	C4-1/8-T0-1002-F
A1R712	0757-0442	9	1	RESISTOR 10K 1% .125W F TC=0+-100	24546	C4-1/8-T0-1002-F
A1R713	0757-0449	6	1	RESISTOR 20K 1% .125W F TC=0+-100	24546	C4-1/8-T0-2002-F
A1R714	0757-0433	8	1	RESISTOR 3.32K 1% .125W F TC=0+-100	24546	C4-1/8-T0-3321-F
A1R715	0757-0283	6	1	RESISTOR 2K 1% .125W F TC=0+-100	24546	C4-1/8-T0-2001-F
A1R716	0698-3228	9	1	RESISTOR 49.7K 1% .125W F TC=0+-100	20400	0698-3228
A1R717	2100-3210	6	1	RESISTOR-TRMR 10K 10% C TOP-ADJ 1-TRN	20400	2100-3210
A1R718	0698-4502	4	1	RESISTOR 64.9K 1% .125W F TC=0+-100	24546	C4-1/8-T0-6492-F

See introduction to this section for ordering information  
 \*Indicates factory selected value

Table 6-3. Replaceable Parts (Cont'd)

Reference Designation	HP Part Number	C D	Qty	Description	Mfr Code	Mfr Part Number
A1R719	0698-3279	0	1	RESISTOR 4.97K 1% .125W F TC=0+/-100	24546	C4-1/8-T0-4991-F
A1R720	0698-4842	5		RESISTOR 124 1% .5W F TC=0+/-100	20480	0698-4842
A1R721	0683-0275	9		RESISTOR 2.7 5% .25W FC TC=-400/+500	01121	CB27G5
A1R722	0683-0275	9		RESISTOR 2.7 5% .25W FC TC=-400/+500	01121	CB27G5
A1R723	0683-0275	9		RESISTOR 2.7 5% .25W FC TC=-400/+500	01121	CB27G5
A1R724	0683-0275	9	RESISTOR 2.7 5% .25W FC TC=-400/+500	01121	CB27G5	
A1R725	0683-0275	9	RESISTOR 2.7 5% .25W FC TC=-400/+500	01121	CB27G5	
A1R726	0683-4725	2	RESISTOR 4.7K 5% .25W FC TC=-400/+700	01121	CB4725	
A1R727	0683-0275	9	RESISTOR 2.7 5% .25W FC TC=-400/+500	01121	CB27G5	
A1R728	0683-4725	2	RESISTOR 4.7K 5% .25W FC TC=-400/+700	01121	CB4725	
A1R730	0683-4725	2	RESISTOR 4.7K 5% .25W FC TC=-400/+700	01121	CB4725	
A1RT300	0839-0026	9	1	THERMISTOR DISC 10K-OHM TC=-4.4%/C-DEC	20480	0839-0026
A1S1-14	03466-61901	2	1	SWITCH ASSEMBLY	20480	03466-61901
A1S1	3101-2129	7	1	SWITCH: PB 6PPT ALTING .45A 115VAC	20480	3101-2129
A1S2	3101-2120	6	4	SWITCH: PB 6PPT INTLH .45A 115VAC	20480	3101-2120
A1S3	3101-2128	6	1	SWITCH: PB 6PPT INTLH .45A 115VAC	20480	3101-2128
A1S4	3101-2127	5	3	SWITCH-PB 6PDT INTLH .45A 115VAC	20480	3101-2127
A1S5	3101-2127	5	6	SWITCH-PB 6PDT INTLH .45A 115VAC	20480	3101-2127
A1S6	3101-2127	5		SWITCH-PB 6PDT INTLH .45A 115VAC	20480	3101-2127
A1S7	3101-2130	0		SWITCH-PB DPST INTLH .45A 115VAC	20480	3101-2130
A1S8	3101-2130	0		SWITCH-PB DPST INTLH .45A 115VAC	20480	3101-2130
A1S9	3101-2130	0		SWITCH-PB DPST INTLH .45A 115VAC	20480	3101-2130
A1S10	3101-2130	0		SWITCH-PB DPST INTLH .45A 115VAC	20480	3101-2130
A1S11	3101-2130	0	SWITCH-PB DPST INTLH .45A 115VAC	20480	3101-2130	
A1S12	3101-2128	0	SWITCH: PB 6PPT INTLH .45A 115VAC	20480	3101-2128	
A1S13	3101-2130	0	SWITCH-PB DPST INTLH .45A 115VAC	20480	3101-2130	
A1S14	3101-2128	0	SWITCH: PB 6PPT INTLH .45A 115VAC	20480	3101-2128	
A1700	9100-3494	5	1	TRANSFORMER-POWER 115V 47-440HZ	20480	9100-3494
A1U100	5957-5122	1	1	LD NOISE LF357	20480	5957-5122
A1U102	1813-0096	0	1	INPUT HYBRID	20480	1813-0096
A1U104	1026-0174	2	1	IC COMPARATOR GP QUAD 14-DIP-P PKG	20480	1026-0174
A1U200	1026-0059	2	1	IC OP AMP GP TO-99 PKG	01295	LM201AL
A1U300	1026-0935	3	1	RMS/DC 14-CBRZ/SDR EPLR	20480	1026-0935
A1U400	1026-0561	1	1	IC OP AMP GP TO-99 PKG	20480	1026-0561
A1U402	1013-0097	1	1	INTEG HYBRID	20480	1013-0097
A1U404	1058-0054	4	2	TRANSISTOR ARRAY 16-PIN PLSTC DIP	20480	1058-0054
A1U406	1058-0054	4	1	TRANSISTOR ARRAY 16-PIN PLSTC DIP	20480	1058-0054
A1U500	1026-0043	4	3	IC OP AMP GP TO-99 PKG	3L505	CA307T
A1U600	1026-0043	4	1	IC OP AMP GP TO 99 PKG	3L505	CA307T
A1U700	1026-0196	6		IC 723 V RGLTR TO-100	04713	MC1723CG
A1U701	1026-0043	4		IC OP AMP GP TO-99 PKG	3L505	CA307T
A1 MISCELLANEOUS PARTS						
A1FX701	2110-0269	0	2	FUSEHOLDER-CLIP TYPE.25D-FUSE	20480	2110-0269
A1X300	1200-0424	9	1	SOCKET-IC 14-CONT DIP DIP-SLDR	20480	1200-0424
	0340-0060	4	5	TERMINAL-STUD SPCL-FDTHRU PRESS-MTG	90291	011-6809 000 209
	0340-0092	2	1	TERMINAL-STUD SPCL-FDTHRU PRESS-MTG	20400	0340-0092
	0370-2406	5	7	KEY CAP LIGHT GRAY (RANGE SWITCHES)	20480	0370-2406
	0370-2625	4	1	KEY CAP WHITE (POWER)	20480	0370-2625
	0370-2073	4	5	KEY CAP DARK GRAY (FUNCTION SWITCHES)	20480	0370-2073
	0370-2917	7	1	KEY CAP BLUE (AUTO)	20480	0370-2917
	0380-1089	3	3	STANDOFF-RVT-ON .7-IN-LG 6-32THD	00000	ORDER BY DESCRIPTION
	1460-1485	4	1	SPRING-LEAF .25-IN-W 1.555-IN-DA-LG BC	20480	1460-1485
	1600-0678	3	1	STAMPING-DE-CU CONNECTOR STRIP-12 PIN	20480	1600-0678
	1600-0679	4	1	STAMPING-BE-CU CONNECTOR STRIP-17 PIN	20480	1600-0679
	5040-0068	7	1	HOLDER, SPRING	20480	5040-0068
	03466-24701	2	2	SPACER-HYBRID	20480	03466-24701
A2	03466-66570	9	1	PC ASSEMBLY: DISPLAY	20480	03466-66570
	03466-66517	6	1	PC ASSEMBLY: DISPLAY (1716A01831 TO 1716A1160)	20480	03466-66517
	03466-66502	9	1	PC ASSEMBLY: DISPLAY (1716A01830 & BELOW)	20480	03466-66502
A2DS001	1990-0404	8	7	LED-LAMP LUM-INT=300UCD IF=50MA-MAX	20480	5082-4480
A2DS002	1990-0404	8	1	LED-LAMP LUM-INT=310UCD IF=50MA-MAX	20480	5082-4480
A2DS003	1990-0404	8	1	LED-LAMP LUM-INT=300UCD IF=50MA-MAX	20480	5082-4480
A2DS004	1990-0404	8	1	LED-LAMP LUM-INT=300UCD IF=50MA-MAX	20480	5082-4480
A2DS005	1990-0404	8	1	LED-LAMP LUM-INT=300UCD IF=50MA-MAX	20480	5082-4480
A2DS006	1990-0404	8	1	LED-LAMP LUM-INT=300UCD IF=50MA-MAX	20480	5082-4480
A2DS007	1990-0404	8	1	LED-LAMP LUM-INT=300UCD IF=50MA-MAX	20480	5082-4480
A2DSM001	1990-0532	3	1	DISPLAY-NUM-SEG .5-CHAR .29-H	20480	5082-7612
A2DSM002	1990-0531	2	4	DISPLAY-NUM-SEG 1-CHAR .3-H	20480	5002-7610
A2DSM003	1990-0531	2	1	DISPLAY-NUM-SEG 1-CHAR .3-H	20480	5082-7610

See introduction to this section for ordering information  
 \*Indicates factory selected value

Table 6-3. Replaceable Parts (Cont'd)

Reference Designation	HP Part Number	C D	Qty	Description	Mfr Code	Mfr Part Number
A2DGH004	1990-0531	2		DISPLAY-NUM SEC 1-CHAR .3-H	28480	5002-7610
A2DGH005	1990-0531	2		DISPLAY-NUM-SEC 1-CHAR .3-H	20480	5062-7610
A2P1	1251-4112	7	1	CONNECTOR 25-PIN M POST TYPE	28480	1251-4112
A2R026	0683-1115	8	14	RESISTOR 110 5% .25W FC TC=-400/+600	01121	CB1115
A2R028	0603-1115	0		RESISTOR 110 5% .25W FC TC=-400/+600	01121	CB1115
A2R032	0683-1115	8		RESISTOR 110 5% .25W FC TC=-400/+600	01121	CB1115
A2R034	0603-1115	8		RESISTOR 110 5% .25W FC TC=-400/+600	01121	CB1115
A2R036	0683-1115	8		RESISTOR 110 5% .25W FC TC=-400/+600	01121	CB1115
A2R038	0603-1115	8		RESISTOR 110 5% .25W FC TC=-400/+600	01121	CB1115
A2R040	0683-1115	8		RESISTOR 110 5% .25W FC TC=-400/+600	01121	CB1115
A2R042	0603-2215	1	3	RESISTOR 220 5% .25W FC TC=-400/+600	01121	CB2215
A2R044	0683-1115	8		RESISTOR 110 5% .25W FC TC=-400/+600	01121	CB1115
A2R046	0603-1115	8		RESISTOR 110 5% .25W FC TC=-400/+600	01121	CB1115
A2R048	0683-1115	8		RESISTOR 110 5% .25W FC TC=-400/+600	01121	CB1115
A2R049	0603-1115	0		RESISTOR 110 5% .25W FC TC=-400/+600	01121	CB1115
A2R050	0683-1115	6		RESISTOR 110 5% .25W FC TC=-400/+600	01121	CB1115
A2R052	0603-1115	0		RESISTOR 110 5% .25W FC TC=-400/+600	01121	CB1115
A2R054	0683-1115	8		RESISTOR 110 5% .25W FC TC=-400/+600	01121	CB1115
A2R056	0683-2215	1		RESISTOR 220 5% .25W FC TC=-400/+600	01121	CB2215
A2R058	0683-2215	1		RESISTOR 220 5% .25W FC TC=-400/+600	01121	CB2215
A2 MISCELLANEOUS PARTS						
	1530-2062	4	1	DISPLAY MASK	28480	1530-2062
A3	03435-66003	6	1	PC ASSEMBLY: BATTERY	20400	03435-66803
A3CB01	0160-3847	9		CAPACITOR-FXD .01UF +100-0% 50VDC CER	28480	0160-3847
A3CB02	0160-3847	7		CAPACITOR-FXD .01UF +100 0% 50VDC CER	28480	0160-3847
A3CB03	0180-1743	2	1	CAPACITOR-FXD .1UF+10% 35VDC TA	56289	150D104X9035A2
A3CB05	0150-0004	7	1	CAPACITOR-FXD .1UF +00-20% 100VDC CER	28480	0150-0004
A3CB06	0160-2204	0		CAPACITOR-FXD 100PF +-5% 300VDC MICA	28480	0160-2204
A3CB07	0140-0195	2	1	CAPACITOR-FXD 130PF +-5% 300VDC MICA	72136	DM15F131J0300WV1CR
A3CB08	0180-0369	4	1	CAPACITOR-FXD 4.7UF+-20% 10VDC TA	56289	150D475X0010A2
A3CB09	0160-3847	7		CAPACITOR-FXD .01UF +100 0% 50VDC CER	28480	0160-3847
A3CB10	0160-3847	9		CAPACITOR-FXD .01UF +100 0% 50VDC CER	28480	0160-3847
A3CR001	1901-0040	1		DIODE-SWITCHING 30V 50MA 2NS DO-35	28480	1901-0040
A3CR002	1902-3182	0	1	DIODE ZNR 12.1V 5% DO-35 PD=.4W	20480	1902-3182
A3CR004	1901-0040	1		DIODE-SWITCHING 30V 50MA 2NS DO-35	28480	1901-0040
A3CR005	1901-0040	1		DIODE-SWITCHING 30V 50MA 2NS DO-35	28480	1901-0040
A3CR006	1901-0040	1		DIODE-SWITCHING 30V 50MA 2NS DO-35	28480	1901-0040
A3CR007	1901-0040	1		DIODE-SWITCHING 30V 50MA 2NS DO-35	28480	1901-0040
A3CR009	1901-0040	1		DIODE-SWITCHING 30V 50MA 2NS DO-35	28480	1901-0040
A3CR010	1901-0040	1		DIODE-SWITCHING 30V 50MA 2NS DO-35	28480	1901-0040
A3CR011	1901-0040	1		DIODE-SWITCHING 30V 50MA 2NS DO-35	28480	1901-0040
A3CR012	1910-0034	2	4	DIODE-GE 30V 00MA 0NS DO-7	28480	1910-0034
A3CR013	1910-0034	2		DIODE-GE 30V 00MA 0NS DO-7	28480	1910-0034
A3CR014	1910-0034	2		DIODE-GE 30V 00MA 0NS DO-7	28480	1910-0034
A3CR015	1910-0034	2		DIODE-GE 30V 00MA 0NS DO-7	28480	1910-0034
A3CR016	1901-0535	7	2	DIODE-SM SIG SCHOTTKY	28480	1901-0535
A3CR017	1901-0535	9		DIODE-SM SIG SCHOTTKY	28480	1901-0535
A3FB01	2110-0002	9	2	FUSE 2A 250V NTD 1.25X.25 UL	75915	312002
A3JB01	1251-4401	7		CONNECTOR 10-PIN M POST TYPE	28480	1251-4401
A3QB01	1053-0010	2	1	TRANSISTOR PNP SI TO-18 PD=360MW	28480	1053-0010
A3QB02	1054-0063	7	1	TRANSISTOR NPN 2N3055 SI TO-3 PD=115W	3L505	2N3055
A3QB03	1054-0007	5	3	TRANSISTOR NPN SI PD=360MW FT=75MHZ	28480	1054-0087
A3QB04	1054-0087	5		TRANSISTOR NPN SI PD=360MW FT=75MHZ	28480	1054-0087
A3QB05	1054-0007	5		TRANSISTOR NPN SI PD=360MW FT=75MHZ	28480	1054-0087
A3RB01	0683-3335	8	3	RESISTOR 33K 5% .25W FC TC=-400/+000	01121	CB3335
A3RB02	0603-1515	2	1	RESISTOR 150 5% .25W FC TC=-400/+600	01121	CB1515
A3RB03	0683-3325	6	3	RESISTOR 3.3K 5% .25W FC TC=-400/+700	01121	CB3325
A3RB04	0757-0465	6	1	RESISTOR 100K 1% .125W F TC=0+-100	24546	C4-1/8-T0-1003-F
A3RB05	0698-4508	0	1	RESISTOR 78.7K 1% .125W F TC=0+-100	24546	C4-1/8-T0-7872-F
A3RB06	0678-3148	2	1	RESISTOR 102K 1% .125W F TC=0+-100	24546	C4-1/8-T0-1023-F
A3RB07	0698-4510	2	1	RESISTOR 137K 1% .125W F TC=0+-100	24546	C4-1/8-T0-1373-F
A3RB08	0603-1045	3		RESISTOR 100K 5% .25W FC TC=-400/+800	01121	CB1045
A3RB09	0757-0479	2	2	RESISTOR 392K 1% .125W F TC=0+-100	19701	MFAC1/8-T0-3923-F
A3RB10	0670-4431	8	1	RESISTOR 2.05K 1% .125W F TC=0+-100	24546	C4-1/8-T0-2051-F
A3RB11	0812-0040	1	1	RESISTOR .27 5% .5W PW TC=0+-300	75042	BW20-1/2-27/100-J
A3RB12	0683-1045	3		RESISTOR 100K 5% .25W FC TC=-400/+000	01121	CB1045
A3RB13	0698-3279	0		RESISTOR 4.99K 1% .125W F TC=0+-100	24546	C4-1/8-T0-4991-F
A3RB14	0698-3149	3	1	RESISTOR 255K 1% .125W F TC=0+-100	24546	C4-1/8-T0-2553-F
A3RB15	0698-4531	9	1	RESISTOR 267K 1% .125W F TC=0+-100	24546	C4-1/8-T0-2673-F

See introduction to this section for ordering information  
 \*Indicates factory selected value

Table 6-3. Replaceable Parts (Cont'd)

Reference Designation	HP Part Number	C D	Qty	Description	Mfr Code	Mfr Part Number
A3R816	0683-1055	5		RESISTOR 1M 5% .25W FC TC=-800/+900	01121	CB1355
A3R817	0683-1055	5		RESISTOR 1M 5% .25W FC TC=-800/+900	01121	CB1055
A3R818	2100-0558	9	1	RESISTOR-TRMR 20K 10% C TOP-ADJ 1 TRN	20400	2100-0558
A3R819	0683-4755	8	1	RESISTOR 4.7M 5% .25W FC TC=-900/+1100	01121	CB4755
A3R820	0757-0479	2		RESISTOR 392K 1% .125W F TC=0+-100	19701	NF4C1/B-T0-3923-F
A3R821	0683-3335	8		RESISTOR 33K 5% .25W FC TC=-400/+800	01121	CB3335
A3R822	0603-3335	8		RESISTOR 33K 5% .25W FC TC=-400/+800	01121	CB3335
A3R823	0683-1045	3		RESISTOR 100K 5% .25W FC TC=-400/+800	01121	CB1045
A3R824	0683-3325	6		RESISTOR 3.3K 5% .25W FC TC=-400/+700	01121	CB3325
A3R825	0683-3325	6		RESISTOR 3.3K 5% .25W FC TC=-400/+700	01121	CB3325
A3R826	0683-1005	5		RESISTOR 10 5% .25W FC TC=-400/+500	01121	CB1005
A3R827	0698-3268	7		RESISTOR 11.5K 1% .125W F TC=0+-100	24546	C4-1/8-T0-1152-F
A3T801	9100-3920	2	1	TRANSFORMER: PULSE	20400	9100-3920
A3U801	1026-0139	9	1	IC OP AMP GP DUAL 8-DIP-P PKG	3L585	CA1458C
A3U802	1020-0944	2	1	IC GATE CMOS NOR TPL 3-INP	3L585	CD4025UBE
A3U803	1020-0930	4	1	IC FT CMOS J-K M/S POS-EDGE-TRIC DUAL	3L585	CD4027BE
A3U804	1020-0949	7	1	IC GATE CMOS NAND QUAD 2-INP	3L585	CD4011UBE
A3 MISCELLANEOUS PARTS						
A3FX801	2110-0269	0		FUSEHOLDER-CLIP TYPE.25D-FUSE	20400	2110-0269
BT801	1420-0233	4	2	BATTERY 6V 2.5A-HR PB-ACID POST	20400	1420-0233
W1	03435-6160	2	2	BATTERY CABLE WITH CONNECTORS	20400	03435-61601
	2360-0115	4	4	SCREW-MACH 6-32 .312-IN-LG PAN-HD-POZI	00000	ORDER BY DESCRIPTION
	2420-0001	5	2	NUT-HEX-W/LKWR 6-32-THD .109-IN-THK	00000	ORDER BY DESCRIPTION
	8120-2365	8	2	TEST GEAR ASSY 22-AWG 1-COND 2.375-IN-LG	20400	8120-2365
A4	03466-6651	3	1	PC ASSEMBLY: LOGIC	20400	03466-66514
	03466-6650	1	1	PC ASSEMBLY: LOGIC (1716A00450 & BELOW)	20400	03466-66504
A4C900	0160-2257	3		CAPACITOR-FXD 10PF +-5% 500VDC CER 0+-60	20400	0160-2257
A4C902	0160-0161	4	1	CAPACITOR-FXD .01UF +-10% 200VDC POLY	20400	0160-0161
A4C904	0160-0157	8	1	CAPACITOR-FXD 4700PF +-10% 200VDC POLYE	20400	0160-0157
A4C906	0160-3622	8		CAPACITOR-FXD .1UF +RD-20% 100VDC CER	26654	2130YSW100R104Z
A4C907	0100-0291	3		CAPACITOR-FXD 1UF+-10% 35VDC TA	56209	150D105X9035A2
A4C908	0100-0197	8	1	CAPACITOR-FXD 2.2UF+-10% 20VDC TA	56209	150D225X9020A2
A4J901	1251-4166	1	1	CONNECTOR 25-PIN F POST TYPE	20400	1251-4166
A4J902	1251-4919	2	1	CONNECTOR 25-PIN F POST TYPE	20400	1251-4919
A4L900	9140-0210	1	1	INDUCTOR RF-CH-MLD 100UH 5% .166DX.305LG	20400	9140-0210
A4L901	9140-3912	6	1	COIL 15UH	20400	9140-3912
A4P902	1251-4910	1	2	CONNECTOR 12-PIN M POST SERIES	20400	1251-4910
A4Q900	1053-0016	8	4	TRANSISTOR PNP SI TO-92 PD=300MW	20400	1053-0016
A4Q902	1053-0016	0		TRANSISTOR PNP SI TO-92 PD=300MW	20400	1053-0016
A4Q904	1053-0016	8		TRANSISTOR PNP SI TO-92 PD=300MW	20400	1053-0016
A4Q906	1053-0016	8		TRANSISTOR PNP SI TO-92 PD=300MW	20400	1053-0016
A4Q908	1054-0071	7		TRANSISTOR NPN SI PD=300MW FT=200MHZ	20400	1054-0071
A4R900	0603-1045	3		RESISTOR 100K 5% .25W FC TC=-400/+800	01121	CB1045
A4R904	0698-3228	9		RESISTOR 49.9K 1% .125W F TC=0+-100	20400	0698-3228
A4R905	0698-3228	9		RESISTOR 49.9K 1% .125W F TC=0+-100	20400	0698-3228
A4R906	0683-1045	3		RESISTOR 100K 5% .25W FC TC=-400/+800	01121	CB1045
A4R908	0683-2035	3	5	RESISTOR 20K 5% .25W FC TC=-400/+800	01121	CB2035
A4R910	0683-0215	3	8	RESISTOR 820 5% .25W FC TC=-400/+600	01121	CB0215
A4R912	0683-0215	3		RESISTOR 820 5% .25W FC TC=-400/+600	01121	CB0215
A4R914	0683-0215	3		RESISTOR 820 5% .25W FC TC=-400/+600	01121	CB0215
A4R916	0683-0215	3		RESISTOR 820 5% .25W FC TC=-400/+600	01121	CB0215
A4R918	0683-0215	3		RESISTOR 820 5% .25W FC TC=-400/+600	01121	CB0215
A4R920	0683-0215	3		RESISTOR 820 5% .25W FC TC=-400/+600	01121	CB0215
A4R922	0683-0215	3		RESISTOR 820 5% .25W FC TC=-400/+600	01121	CB0215
A4R924	0683-0215	3		RESISTOR 820 5% .25W FC TC=-400/+600	01121	CB0215
A4R926	2100-2666	4	1	R-V 100K OHM	20400	2100-2666
A4R928	0683-2035	3		RESISTOR 20K 5% .25W FC TC=-400/+800	01121	CB2035
A4R930	0683-2035	3		RESISTOR 20K 5% .25W FC TC=-400/+800	01121	CB2035
A4R932	0683-2035	3		RESISTOR 20K 5% .25W FC TC=-400/+800	01121	CB2035
A4R934	0683-2035	3		RESISTOR 20K 5% .25W FC TC=-400/+800	01121	CB2035
A4R936	0683-5115	6	4	RESISTOR 510 5% .25W FC TC=-400/+600	01121	CB5115
A4R938	0683-5115	6		RESISTOR 510 5% .25W FC TC=-400/+600	01121	CB5115
A4R940	0683-5115	6		RESISTOR 510 5% .25W FC TC=-400/+600	01121	CB5115
A4R942	0683-5115	6		RESISTOR 510 5% .25W FC TC=-400/+600	01121	CB5115
A4R944	0603-1535	6	3	RESISTOR 15K 5% .25W FC TC=-400/+800	01121	CB1535
A4R946	0683-1535	6		RESISTOR 15K 5% .25W FC TC=-400/+800	01121	CB1535
A4R948	0603-1535	6		RESISTOR 15K 5% .25W FC TC=-400/+800	01121	CB1535

See introduction to this section for ordering information  
 \*Indicates factory selected value

Table 6-3. Replaceable Parts (Cont'd)

Reference Designation	HP Part Number	C D	Qty	Description	Mfr Code	Mfr Part Number
A4R949	0603-1535	6		RESISTOR 15K 5% .25W FC TC=-400/+800	01121	CB1535
A4R950	0683-1535	6		RESISTOR 15K 5% .25W FC TC=-400/+800	01121	CB1535
A4R951	0683-1535	6		RESISTOR 15K 5% .25W FC TC=-400/+800	01121	CB1535
A4R952	0683-1535	6		RESISTOR 15K 5% .25W FC TC=-400/+800	01121	CB1535
A4R954	0683-1535	6		RESISTOR 15K 5% .25W FC TC=-400/+800	01121	CB1535
A4R956	0683-1535	6		RESISTOR 15K 5% .25W FC TC=-400/+800	01121	CB1535
A4R958	0683-1535	6		RESISTOR 15K 5% .25W FC TC=-400/+800	01121	CB1535
A4R960	0683-1535	6		RESISTOR 15K 5% .25W FC TC=-400/+800	01121	CB1535
A4R962	0683-1535	6		RESISTOR 15K 5% .25W FC TC=-400/+800	01121	CB1535
A4R964	0683-1535	6		RESISTOR 15K 5% .25W FC TC=-400/+800	01121	CB1535
A4R970	0757-0446	3	1	RESISTOR 15K 1% .125W F TC=0+/-100	24546	C4-1/B-T0-1502-F
A4U901	1820-2254	1	4	IC DRVR TTL LED DRVR HEX	01295	SN75492N
A4U902	1820-1963	7	4	IC FF CMOS D-TYPE POS-EDGE-TRIG DUAL	3L585	CD4013BAE
A4U903	1820-1963	7		IC FF CMOS D-TYPE POS-EDGE-TRIG DUAL	3L585	CD4013BAC
A4U904	1820-1963	7		IC FF CMOS D-TYPE POS-EDGE-TRIG DUAL	3L585	CD4013BAE
A4U905	1820-2254	1		IC DRVR TTL LED DRVR HEX	01295	SN75492N
A4U906	1820-2254	1		IC DRVR TTL LED DRVR HEX	01295	SN75492N
A4U907	1820-1742	0	1	IC MISC NMOS	28480	1820-1742
A4U908	1020-1672	5	1	IC GATE CMOS EXCL-NOR QUAD 2-INP	3L585	CD4077BE
A4U909	1820-1746	4	2	IC BFR CMOS INV HEX	04713	MC14049UBCP
A4U910	1020-1356	2	1	IC MV CMOS MONDSTEL RETRIG/RESET DUAL	04713	MC14528BCP
A4U911	1820-2254	1		IC DRVR TTL LED DRVR HEX	01295	SN75492N
A4U912	1820-1122	0	1	IC CNTR CMOS BCD SYNCHRO DUAL	04713	MC14518BCP
A4U913	1820-1745	3	1	IC GATE CMOS NOR QUAD 2-INP	04713	MC14001BCP
A4U914	1020-1963	7		IC FF CMOS D-TYPE POS-EDGE TRIG DUAL	3L585	CD4013BAE
A4U915	1820-1413	2	1	IC DCDR CMOS BCD-TO-7-SEG 4-TO-7-LINE	3L585	CD4511BE
A4U916	1820-1746	4		IC BFR CMOS INV HEX	04713	MC14049UBCP
A4U917	1820-1965	9	1	IC GATE CMOS NOR TPL 3-INP	04713	MC14025BCP
A4Y900	0410-1121	9	1	CRYSTAL-QUARTZ 200.0000 KHZ	28480	0410-1121
A4 MISCELLANEOUS PARTS						
A4X900	1200-0770	8	1	SOCKET-XTAL 2 CONT HC-6/U DIP-SLDR	28480	1200-0770
	1400-0902	2	1	BRACKET-RTANG .98-LG X .97-LG .65-WD AL	28480	1400-0902
	03466-61601	9	1	TROUBLESHOOTING SERVICE CABLE	28480	03466-61601
MISCELLANEOUS PARTS						
BT801	1420-0233	4		BATTERY 6V 2.5A-HR PB-ACID POST	28480	1420-0233
F2	2110-0002	9		FUSE 2A 250V NTD 1.25X.25 UL	75915	312002
J1	5060-7456	7	2	JACK BANANA (V DIM AND COM)	28480	5060-7456
J2	5060-7455	6	1	FUSEHOLDER (AMPS INPUT)	28480	5060-7455
J3	5060-7456	7		JACK BANANA (V DIM AND COM)	28480	5060-7456
W1	03435-61601	2		CABLE, BATTERY	28480	03435-61601
	4040-1126	3	1	SHELL-TOP B.710 IN-WD 10.056-IN-LG MCP	28480	4040-1126
	4040-1278	6	1	ADJUST-ZERO .42 IN-DIA .44 IN-THK BK	28480	4040-1278
	5040-7223	4	1	PAD, NON SKID (FOOT)	28480	5040-7223
	5040-8058	5	1	HANDLE, BAIL	28480	5040-8058
	5120-1200	5	1	LABEL: INFORMATION	28480	5120-1200
	7120-3530	0	1	LABEL: WARNING	28480	7120-3530
	7120-5370	0	1	LABEL: PULL/ROTATE	28480	7120-5370
	7120-6188	0	1	NAMEPLATE (-HP- LOGO)	28480	7120-6188
	7120-6411	2	1	LABEL: OPERATION	28480	7120-6411
	7120-6465	6	1	LABEL: SERIAL NUMBER	28480	7120-6465
	8120-3547	0	1	TEST LEAD SET	28480	8120-3547
	03435-80001	6	1	BATTERY KIT	28480	03435-80001
	03466-00201	7	1	FRONT PANEL	28480	03466-00201
	03466-00604	4	1	SHIELD: PC (TOP)	28480	03466-00604
	03466-00605	5	1	SHIELD: BOTTOM	28480	03466-00605
	03466-24702	3	1	SHIELD: BOTTOM	28480	03466-24702

See introduction to this section for ordering information  
 \*Indicates factory selected value

**Table 6-4. Mechanical and Miscellaneous Parts**

Index No.	-hp- Part Number	C D	Description
1	4040-1126	3	Top Shell
2	2190-3666	5	A4R926 100k ohm
3	2190-0016	3	Lock Washer
4	5040-8058	5	Handle/Bail
5	2950-0001	8	Hex Nut
6	4040-1278	8	Zero Adjust Spacer
7	03466-66514	3	PC Assembly: Logic (A4)
8	03466-00604	4	PC Shield (Top)
9	2200-0103	2	Screw: 4-40 x .25 Pan Head Pozidrive
10	03466-66578	9	PC Assembly: Display (A2)
11	03466-00201	7	Front Panel
12	0370-2486	5	Key Cap Light Grey (Range Switches)
	0370-2625	4	Key Cap White (Power)
	0370-2873	4	Key Cap Dark Grey (Function Switches)
	0370-2917	7	Key Cap Blue (Auto)
13	5060-7456	7	Banana Jacks (J1, J3)
14	5060-7455	6	Amp Input Fuseholder (J2)
15	03466-24702	3	Bottom Shell
16	2360-0137	0	Screw: 6-32 x 1 3/4
17	2190-0918	4	Lock Washer (Split)
18	5040-7223	4	Pad, Non Skid (Foot)
19	0510-0585	9	Push-On Retainer
20	03466-00605	5	Bottom Shield
21	5040-8044	9	Top Shell Spacer
22	03466-66577	8	PC Assembly: Mother (A1)
23	03466-66503	0	PC Assembly: Battery (A3)
24	03435-01201	2	Battery Clamp
25	1400-0053	4	Cable Clamp
26	1420-0233	4	6V Battery Pack
27	03435-00101	9	Battery Deck
28	7120-6188	0	-hp- Logo
29	2360-0372	5	Screw: Machine Plastic



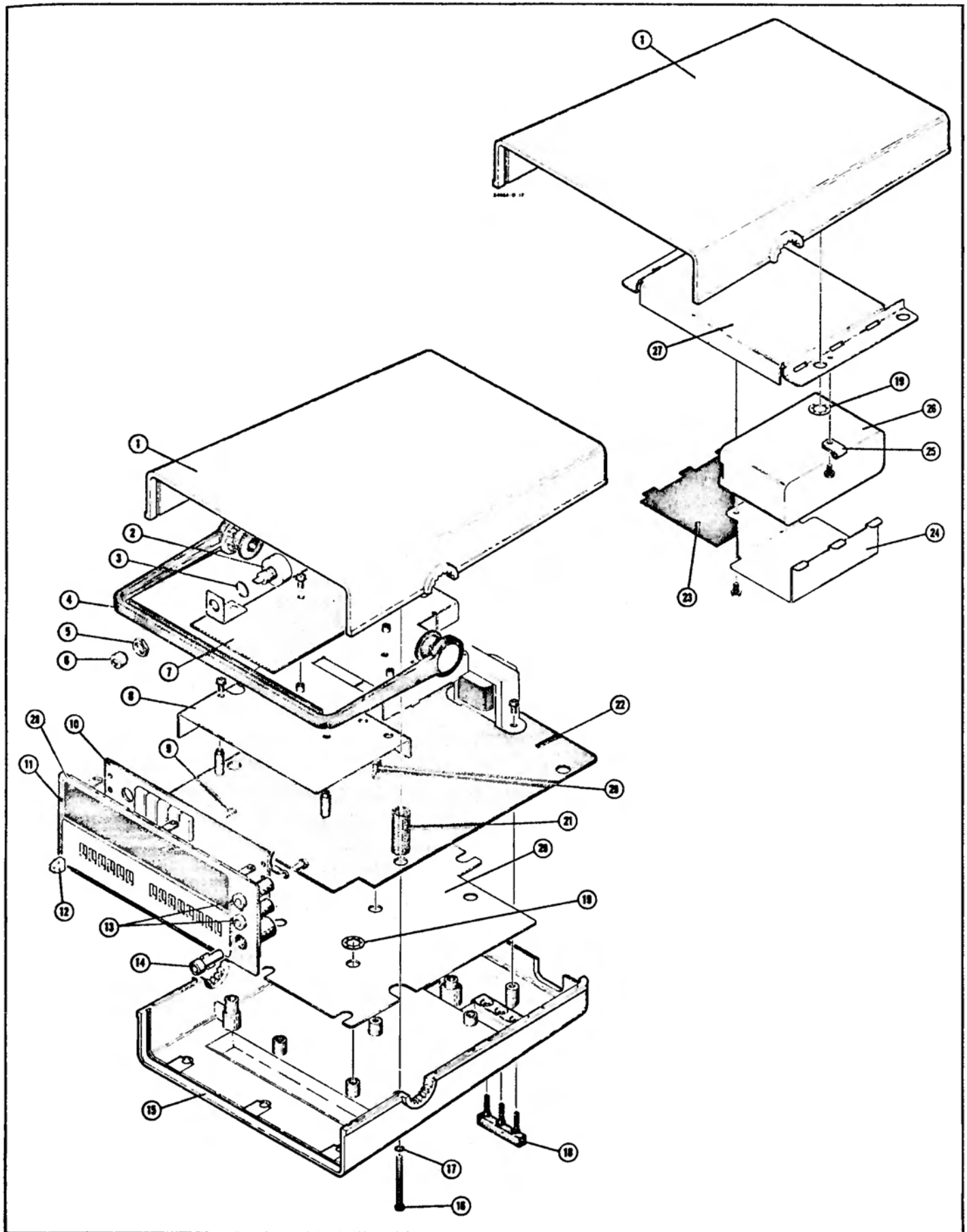
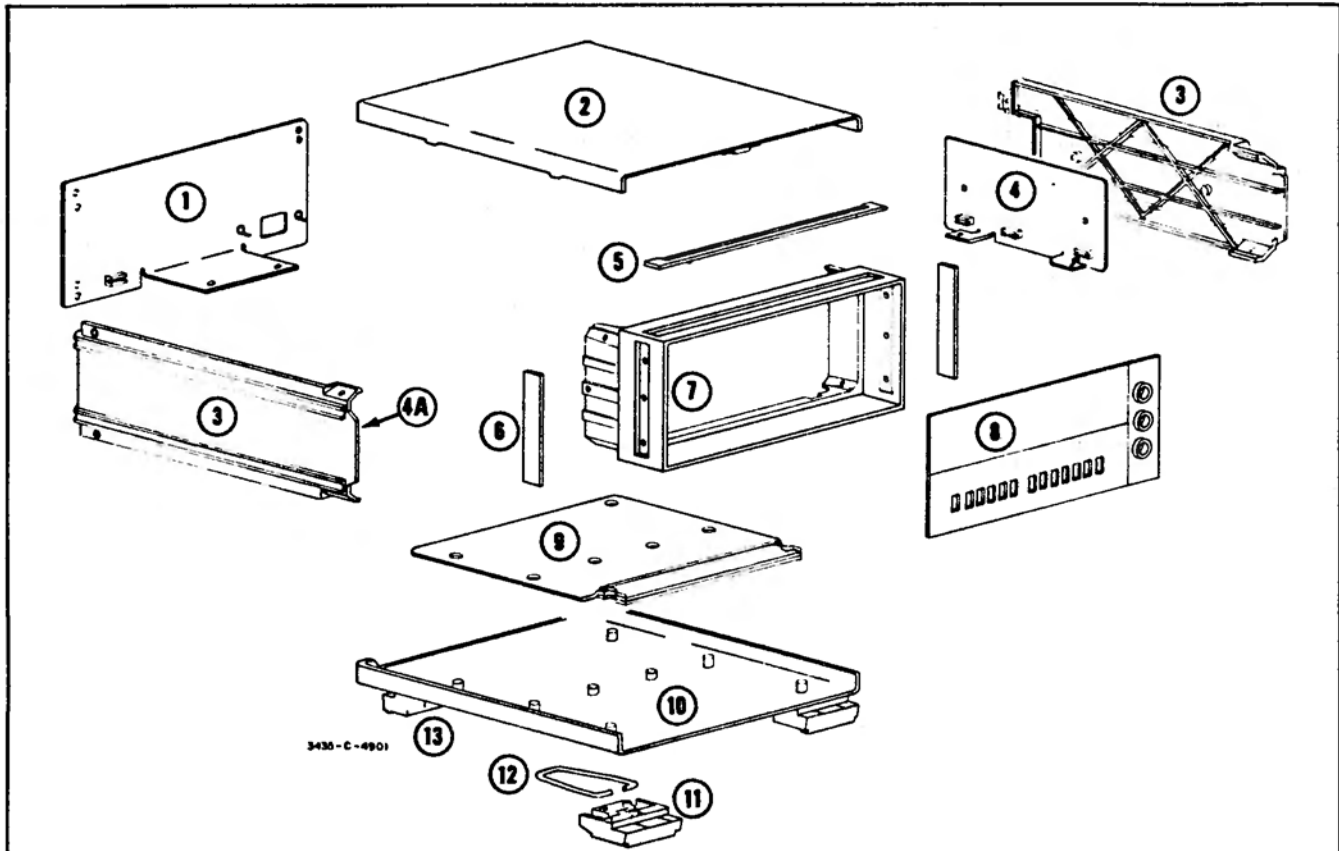

Figure 6-1. 3466A Exploded View (Refer to Table 6-4)

Table 6-5. Option 002 Miscellaneous Parts



Index No.	-hp- Part No.	Description	TQ	Index No.	-hp- Part No.	Description	TQ
1	03466-00202	Rear Panel	1		2360-0113	Side Shield Screws	8
2	5040-7208	Top Cover	1		2680-0128	Grounding Screws	1
3	5040-8210	Side Cover	2		0360-0053	Grounding Lug	1
4	03466-00612	Side Shield, Left	2		2360-0199	Back Panel Screws	6
4A	03466-00613	Side Shield, Right	2		2510-0099	Front Panel Screws	4
5	5040-7203	Top Trim	1		2360-0121	Transformer Screws	2
6	5001-0438	Side Trim	2		2360-0119	Center Screw (A1 PC Board)	1
7	5020-8813	Front Frame	1		2360-0113	Bottom Shield Screws	8
8	03466-00201	Front Panel	1		2360-0199	Top Cover Screws	6
9	03466-00611	Bottom Shield	1		2360-0330	Bottom Cover Screws	2
10	5040-7209	Bottom Cover	1		5040-7853	Square Plastic Washer	4
11	5040-7201	Front Foot	2		7120-3534	Decal	1
12	1460-1345	Tilt Stand	2				
13	5040-7222	Rear Foot	2				

# SECTION VII BACKDATING

## 7-1. INTRODUCTION.

7-2. This section of the manual has backdating information which adapts this manual to instruments with serial numbers and serial number prefixes lower than the ones shown on the title page. If the component values and part numbers in the instrument are different than shown on the schematics and Table 6-3 (Replaceable Parts) and are NOT listed in this section, replace with the component value as presently shown on the schematics and listed in the table.

## 7-3. MANUAL CHANGES

7-4. Refer to Table 7-1 to adapt this manual to instruments with serial numbers and serial prefixes lower than shown on the title page. Make all the appropriate manual changes listed opposite your instrument's serial number. Perform these in the sequence shown in the table.

7-5. If your instrument serial number or prefix is not listed on this manual's title page or in Table 7-1, it may be documented in a yellow MANUAL CHANGES supplement.

**Table 7-1. Manual Changes**

Serial Prefix/Number	Make Manual Changes
1716A00450 and Below	17 thru 13,11,9 thru 6,4,2,1
1716A00525 and Below	17 thru 13,11,9 thru 2
1716A01582 thru 1716A00451	17 thru 13,11 thru 3
1716A01638 thru 1716A00451	17 thru 13,11 thru 4
1716A01830 and Below	17 thru 13,11 thru 5
1716A02330 and Below	17 thru 6
1716A02780 and Below	17 thru 7
1716A02980 and Below	17 thru 8
1716A03380 and Below	17 thru 9
1716A04380 thru 1716A01331	17 thru 10
1716A05530 and Below	17 thru 11
1716A11460 thru 1716A01831	17 thru 12
1716A12147 and Below	17 thru 13
1716A13915 and Below	17 thru 14
1716A14170 and Below	17 thru 15
1716A17005 and Below	17,16
1716A18810 and Below	17

## 7-6. Change #1 (Serial Numbers 1716A00450 and Below)

7-7. Table 6-3 (Replaceable Parts) and Table 6-4 (Miscellaneous Parts) Changes. Change the following in the tables.

Ref. Des.	-hp- Part Number	C D	Description
A4	03466-66504	1	PC Board Assembly: Logic PC Shield (Top)
	03466-00601	1	

The 03466-00603 shield must be used with the 03466-66504 board; the shield presently listed in Tables 6-3 and 6-4 will not fit.

## 7-8. Change #2 (Serial Numbers 1716A00525 and Below)

7-9. Table 6-3 (Replaceable Parts) Changes. Do the changes shown in Table 7-2.

**Table 7-2. Changes in Table 6-3 (Change #2)**

Ref. Des.	-hp- Part Number	C D	Description
A1C115	0180-0374	3	Change to 10 $\mu$ F 20V Capacitor
A1CR113	1901-0040	1	Delete Diode
A1CR115	1901-0040	1	Delete Diode
A1Q105	1855-0270	0	Delete JFET
A1Q107	1855-0270	0	Delete JFET
A1Q106	1855-0308	5	Add Dual JFET DN 324
A1R111	0698-3136	8	Change to 17.8k 1% Resistor
A1R113	0757-0472	5	Change to 200k 1% Resistor
A1R118*	0698-0077	0	Delete 93.1k 1% Resistor
A1R120*	0698-0077	0	Delete 93.1k 1% Resistor
A1R159	0698-8768	2	Delete 100 ohm 1/2W Resistor
A1R207	0757-0288	1	Delete 9.09k 1% Resistor
A1R305	0757-0471	4	Change to 182k 1% Resistor
A1R307	0698-3226	7	Delete 6.94k 1% Resistor
A1RT300	0839-0026	9	Delete Thermistor

7-10. Schematic 1 Changes. Delete R159 from the collector of Q104 and connect the collector to CR122, as shown in Figure 7-1.

7-11. Schematic 2 Changes. Do the following changes on the schematic.

- a. Change Q105 and Q107 to a dual FET Q106.
- b. Delete R118\* and R120\*.

c. Change the current source (Q103) circuitry in the input amplifier as shown in Figure 7-1.

7-12. Schematic 3 Changes. Do the following changes on the schematic.

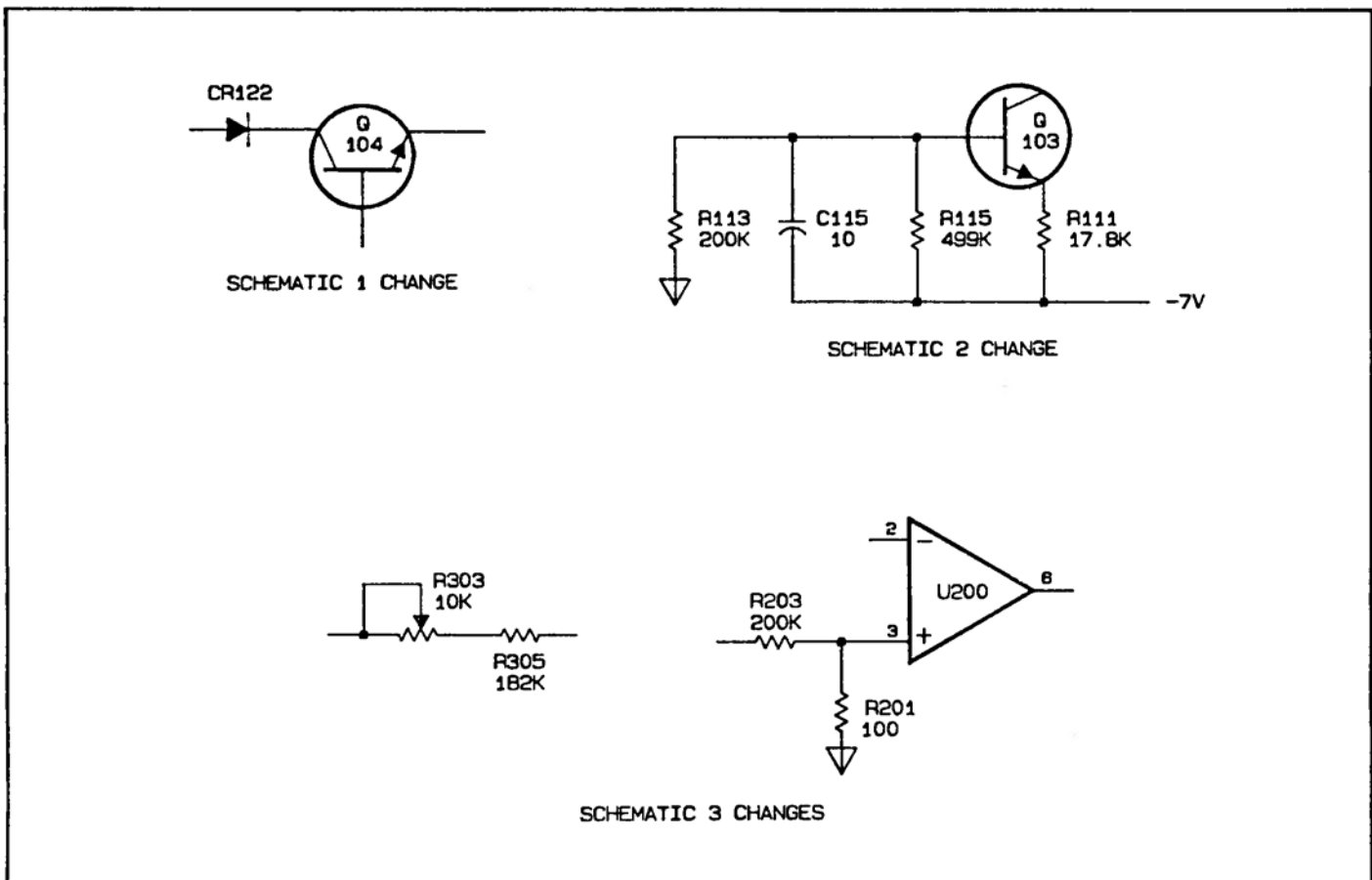

Figure 7-1. Schematics 1, 2, and 3 Changes (Change #2)

a. Delete RT300 and R307, connected to potentiometer R303, and connect R303 to R305 (see Figure 7-1). Also change the value of R305 to 182k.

b. Delete R207 from the + input of U200, as shown in Figure 7-1.

7-13. Component Locator. Use component locator shown in Figure 7-2.

7-14. Change #3 (Serial Numbers 1716A01580 to 1716A00451)

7-15. Table 6-3 (Replaceable Parts) Changes. Delete A4C908 and A4R970 from the table.

7-16. Schematic 4 Changes. Do the following changes:

**NOTE**

*Change #3 may not be necessary in some instruments since they have been changed to the circuitry presently shown on the schematic.*

a. Change the supply voltage on R944, R946, and R948 from +7V to  $V_{DISP}$ .

b. Change the U904 circuitry on the schematic as shown in Figure 7-3.

7-17. Change #4 (Serial Numbers 1716A01638 to 1716A00451)

7-18. Table 6-3 (Replaceable Parts) and Table 6-4 (Miscellaneous Parts) Changes. Change the part number of the shield on the A1 Assembly to 03466-00603 (CD is 3).

7-19. Change #5 (Serial Numbers 1716A01830 and Below)

7-20. Table 6-3 (Replaceable Parts) and Table 6-4 (Miscellaneous Parts) Changes. Change the following in the tables.

Ref. Des.	-hp Part Number	C D	Description
A1	03466-66501	8	PC Assembly: Mother
A2	03466-66502	9	PC Assembly: Display

7-21. Change #6 (Serial Numbers 1716A02330 and Below)

7-22. Table 6-3 (Replaceable Parts) and Table 6-4 (Miscellaneous Parts) Changes. Change the part number of the bottom shield (that sits on the bottom shell) to 03466-00602 (CD is 2). If the bottom shell is replaced, use the shield presently listed in Tables 6-3 and 6-4.

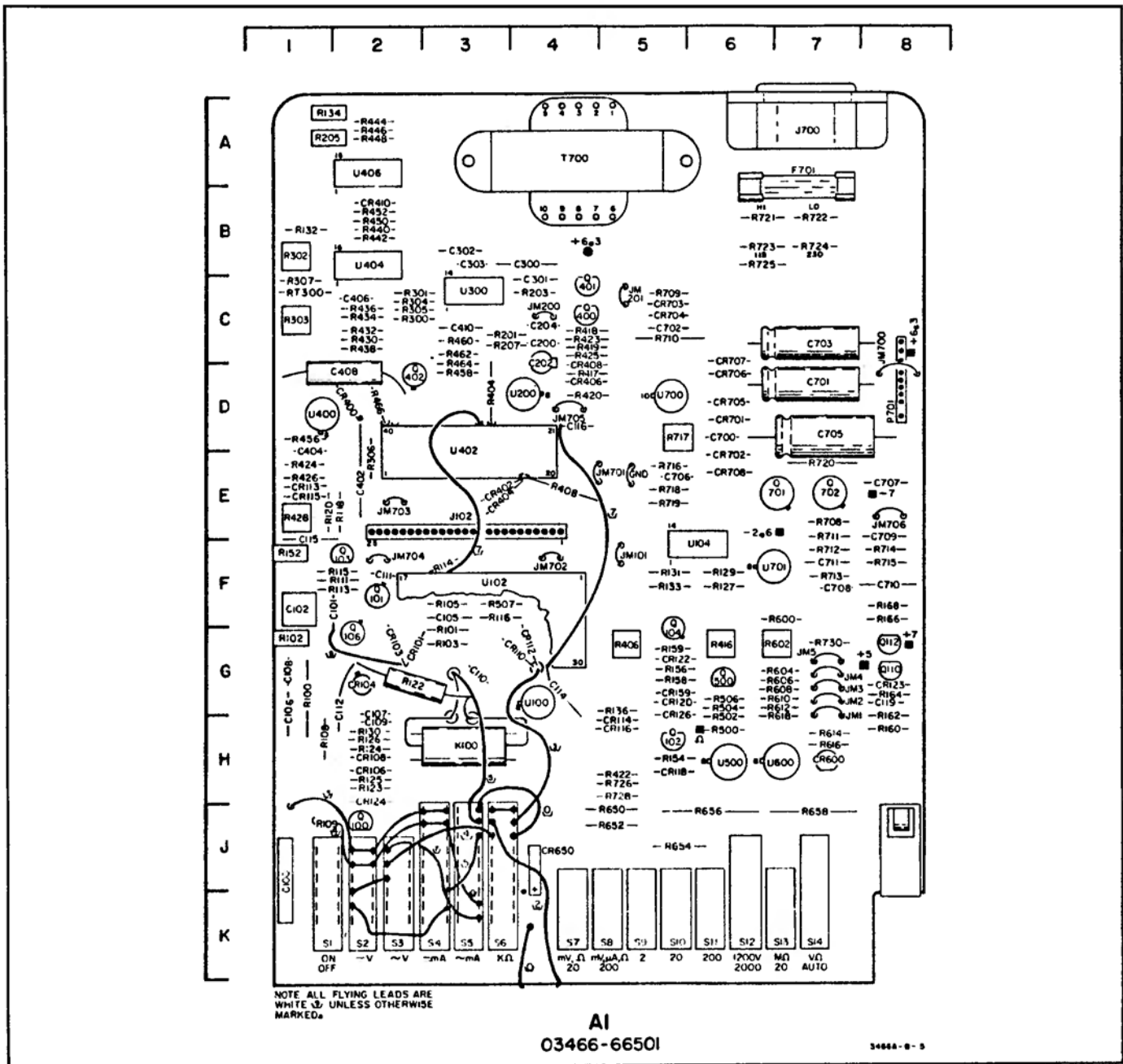

Figure 7-2. Component Locator for Changes #2, 7, and 16

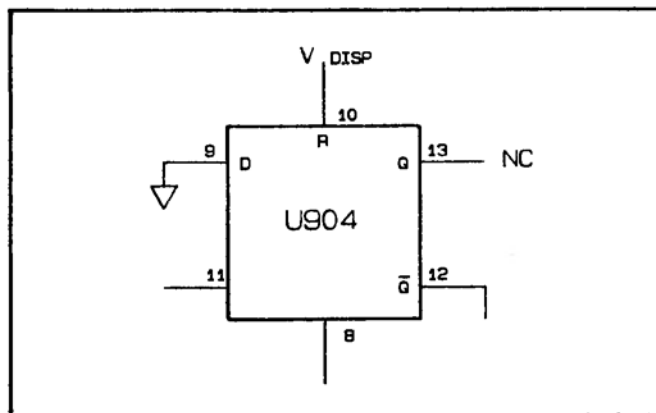

Figure 7-3. Schematic 4 Changes (Change #3)

7-23. Change #7 (Serial Numbers 1716A02780 and Below)

7-24. Table 6-3 (Replaceable Parts) Changes. Change the following in the table.

Ref. Des.	hp Part Number	C	D	Description
A1U400	1826-0478	9		Change to 115KLM308H Op Amp
A1C404	0160-2199	2		Add 30pF 600V Capacitor

A1U400 can be replaced with the op amp part number presently listed in Table 6-3 (1826-0561). If the part number in the table is used, remove C404 from the U400 circuitry.

7-25. Schematic 3 Changes. Add a 30pF capacitor between pins 1 and 8 of U400.

7-26. Component Locator. Use component locator shown in Figure 7-2. Capacitor C404 is located near U400.

7-27. Change #8 (Serial Numbers 1716A02980 and Below)

7-28. Table 6-3 (Replaceable Parts) Changes. Delete R119\* (1.5k ohms; 0757-0427) from the table.

7-29. Schematic 2 Changes. Delete R119\* as shown in Figure 7-4.

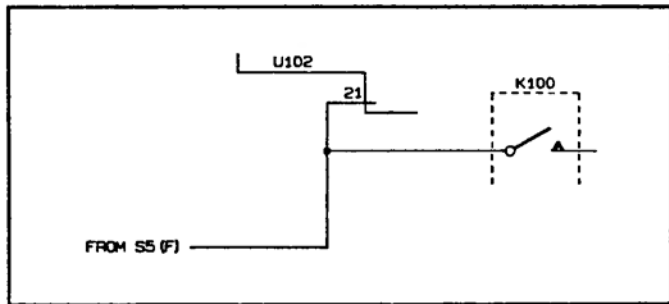

Figure 7-4. Schematic 2 Changes (Change #8)

7-30. Change #9 (Serial Numbers 1716A03380 and Below)

7-31. Table 6-3 (Replaceable Parts) Changes. Change the following in the table.

Ref. Des.	-hp- Part Number	C D	Description
A1C101	0160-4560	5	Change to 62pF Capacitor
A1C102	0121-0128	1	Change to 1.4-9.2pF Var. Capacitor

7-32. Schematic 2 Changes. Change C101 to 62pF and C102 to 1.4-9.2pF.

7-33. Change #10 (Serial Numbers 1716A04380 to 1716A01331)

7-34. Table 6-3 (Replaceable Parts) Changes. Add sockets X901, X905, X906, and X911, part number 1200-0474, to the table. The part number of the sockets is 1200-0474 (CD is 9). These sockets are used for U901, U905, U906 and U911.

7-35. Change #11 (Serial Numbers 1716A05530 and Below)

7-36. Table 6-3 (Replaceable Parts) and Schematic 2 Changes. Change the part number of A1K100 to 0490-1136, and delete A1C117 and R121. A1K100 can be replaced with the relay part number presently listed in Table 6-3 (0490-1247). If the part number in the table is used, add C117 and R121 as shown on Schematic 2 (use component locator presently in the manual to locate C117 and R121).

7-37. Change #12 (Serial Number 1716A11460 to 1716A01831)

7-38. Table 6-3 (Replaceable Parts) and Table 6-4 (Miscellaneous Parts) Changes. Change the following in the tables.

Ref. Des.	-hp- Part Number	C D	Description
A1	03466-66516	5	Change PC Assembly: Mother
A2	03466-66517	6	Change PC Assembly: Display

7-39. Change #13 (Serial Numbers 1716A12147 and Below)

7-40. Table 6-3 (Replaceable Parts) Changes. Change the following in the table.

Ref. Des.	-hp- Part Number	C D	Description
A1Q101	1855-0222	2	Change to FET Dual DN1402
A1R101	0698-3158	4	Change to 23.7k .01 Resistor
A1R103	0698-3158	4	Change to 23.7k .01 Resistor
A1R111	0698-4479	4	Change to 14k .01 Resistor
A1R152	2100-3502	9	Change to 200 Var. Resistor

If A1Q101 is replaced, use the part number (1855-0449) presently listed in Table 6-3. If the part number in the table is used, change R101, R103, R111, and R152 to the part numbers and values presently listed in the table and Schematic 2 (37.4k for R101, R103, and R111, and 500 for R152).

7-41. Schematic #2 Changes. Do the following changes.

Ref. Des.	Value Change
R101	23.7k
R103	23.7k
R111	14k
R152	200

7-42. Change #14 (Serial Numbers 1716A13915 and Below)

7-43. Table 6-3 (Replaceable Parts) and Schematic 4 Changes. Delete connector P904 from the table and Schematic 4. Use component locator in Figure 7-5.

7-44. Change #15 (Serial Numbers 1716A14170 and Below)

7-45. Table 6-3 (Replaceable Parts) Changes. Change the following in the table.

Ref. Des.	-hp- Part Number	C D	Description
A1U300	1826-0421		Change to IC RMS AD536
A1R108	0698-4470		Change to 6.98k .01 Resistor

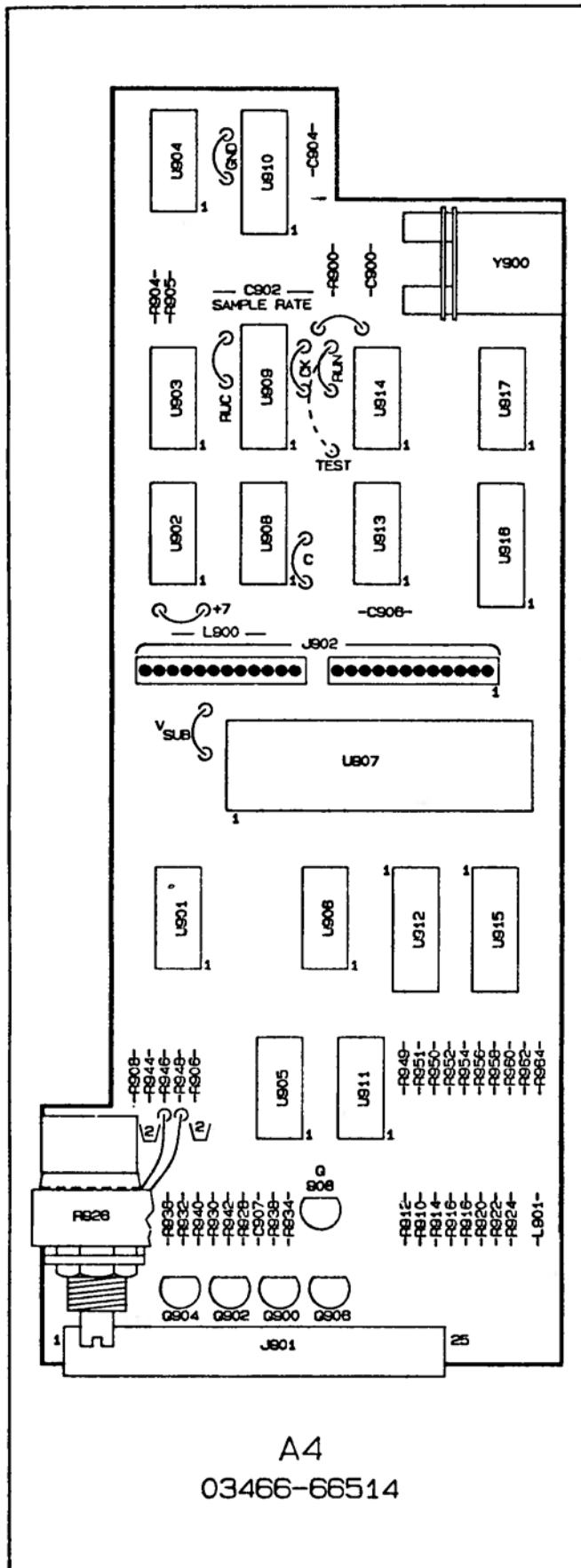

Figure 7-5. Component Locator for Change #14

A1U300 can be replaced with the RMS converter part number presently listed in Table 6-3 (1826-0935). If the part number in the table is used, change R108 to the part number and value presently listed in the table and Schematic 3 (4.99k).

7-46. Schematic 3 Changes. Change the value of R108 to 6.98k.

7-47. Change #16 (Serial Numbers 1716A17005 and Below)

7-48. Table 6-3 (Replaceable Parts) Changes. Delete AIR727 and R128 from the table.

7-49. Schematic 2 Changes. Delete R128 resistor connected to pin 9 of switch S5 and connect the pin to U102 pin 21.

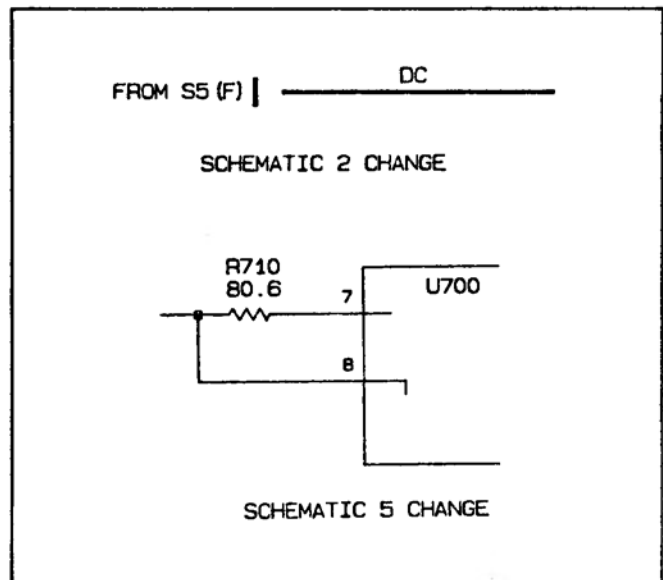

Figure 7-6. Schematics 2 and 5 Changes (Change #16)

7-50. Schematic 5 Changes. Delete R727 between pin 8 of U700 and R710 and connect pin 8 to R710, as shown in Figure 7-6.

7-51. Component Locator. Use component locator in Figure 7-2.

7-52. Change #17 (Serial Numbers 1716A18810 and Below)

7-53. Table 6-3 (Replaceable Parts) Changes. Do the following changes in the table.

Ref. Des.	-hp Part Number	C D	Description
A1C200	0160-2265	3	Add 22pF 500V Capacitor
A1C204	0160-2257	3	Change to 10pf 500V Capacitor
A1C210	0160-2236	8	Add 1pF Capacitor
A1R659	0757-0346	2	Delete 10 .01 1/8W Resistor
A1R660	2100-3383	4	Delete 50 .10 1/2W Var. Resistor
A1R305	0696-3243	8	Change to 178k .01 1/6W Resistor

7-54. Schematic 1 Changes. Delete R659 and potentiometer R660 connected across R658.

c. Add C200 (22pF) capacitor between pins 1 and 2 of U200.

7-55. Schematic 3 Changes. Do the following changes.

a. Change the value of R305 to 178k ohms.

d. Change C204 to 10pF.

b. Add C210\* (1pF) capacitor between pins 2 and 6 of U200.

7-56. Component Locator. Use component locator in Figure 7-7.

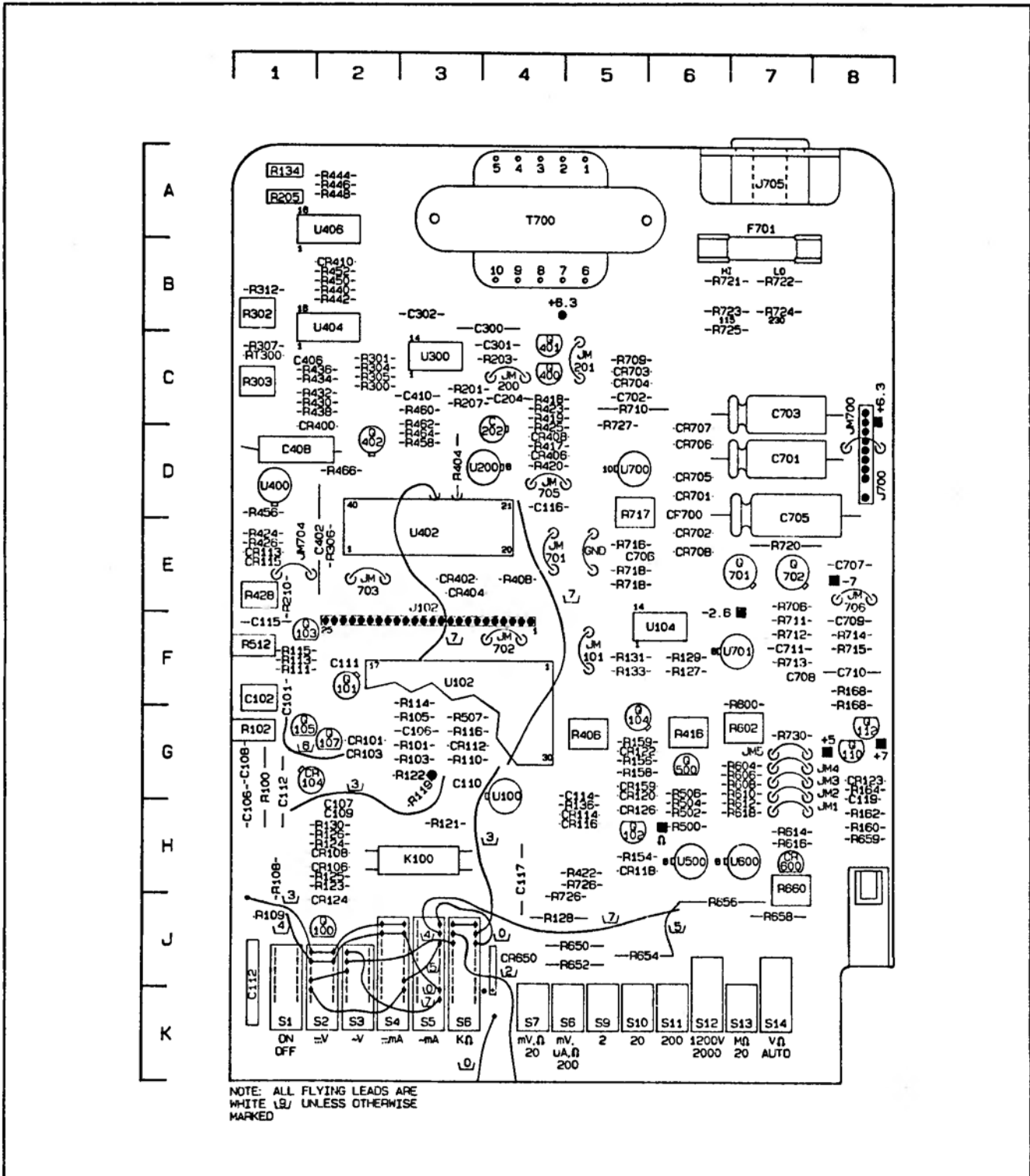

Figure 7-7. Component Locator for Change #17



# SECTION VIII

## SERVICE

### 8-1. INTRODUCTION

8-2. This section contains the Multimeter theory of operation and troubleshooting information. Also included are block diagrams, simplified schematics and complete Multimeter schematics.

8-3. Section VIII is separated as follows:

#### a. Theory of Operation

1. Block Diagram and Simplified Theory
2. Detailed Theory

#### b. Troubleshooting

1. Equipment Required
2. Instrument Disassembly
3. General Troubleshooting Information
4. Failure Isolation
5. Power Supplies Troubleshooting
6. Internal Clock Troubleshooting
7. Function and Range Select Troubleshooting
8. Digital Troubleshooting
9. DC Troubleshooting
10. Ohms Troubleshooting
11. AC Troubleshooting

#### c. Schematics

1. Logic Interface Block Diagram
2. Simplified Analog Schematic
3. Input Switching Schematic (Schematic 1)
4. Ohms Current Source and Input Amplifier Schematic (Schematic 2).
5. Post Amplifier, TRMS Converter, and Analog to Digital Converter Schematic (Schematic 3)
6. Logic and Display Schematic (Schematic 4)
7. Power Supply and Charger Schematic (Schematic 5)

### 8-4. THEORY OF OPERATION

#### 8-5. Block Diagram and Simplified Theory

8-6. Figure 8-1 is a block diagram of the Multimeter. Each block is discussed to give the basic theory of operation of the Multimeter from input to display.

8-7. **Power Supplies.** The power supply provides dc voltage of +7V, -7V, -2.6V and +6.3V ( $V_{DISP}$ ) to the Multimeter circuitry. The +5V reference supply is derived from the +7V and -7V supplies.

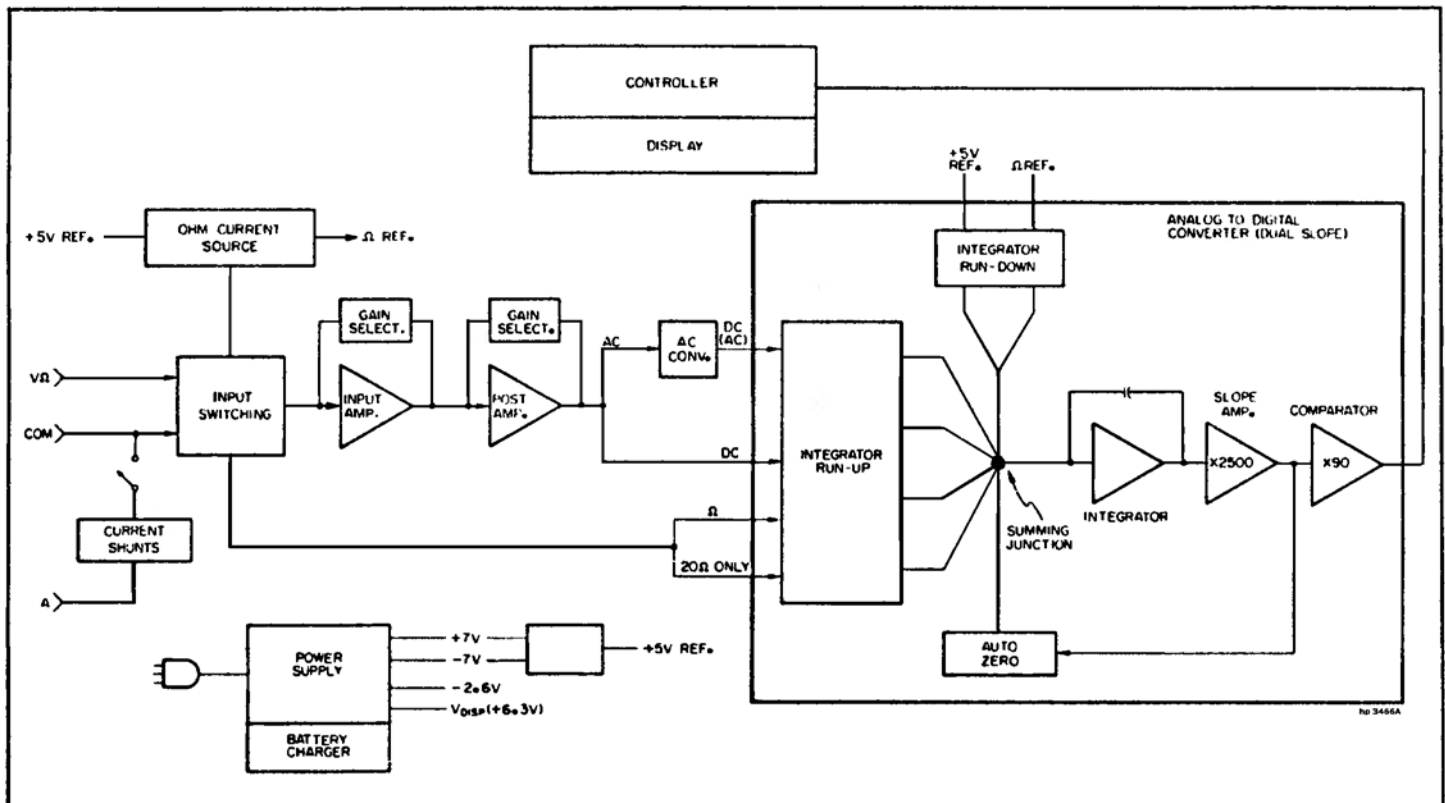

Figure 8-1. Simplified Block Diagram

**8-8. Battery Charger.** The battery charger consists of a three cell rechargeable battery, a current limited charger circuit and a digitally controlled dc to dc converter. The battery charger circuitry operates whenever ac line voltage is connected.

**8-9. Input Switching.** The input switching block consists of the Function switches and the Range switches. These switches program the controller using a 3 line function code (FNA, FNB, FNC) and a 4 line range code (RGD, RGE, RGF, Auto).

**8-10. Input Amplifier.** The input amplifier is a multi-gain operational amplifier. It is used for all five input functions. The gain is selected by MOS FET switches which are controlled by the controller (U907) or by the manual range switches.

**8-11. Post Amplifier.** Ac and dc voltages are amplified by the post amplifier. The gain is x1 or x10 and is selected by MOS FET switches. The switching is controlled by the manual range switches or by the controller (U907).

**8-12. Ohms Current Source.** The ohms current source provides ohms reference voltage to the analog to digital converter and it provides sense current to the "unknown resistance" for each of the 7 ohms ranges.

**8-13. AC Converter.** The AC Converter is a True RMS detector used in ac voltage, dc + ac voltage, ac current and dc + ac current measurements. The output of the AC Converter is a dc voltage equal to the True RMS value of the input voltage. In the ac current and dc + ac current functions, the input voltage to the converter is the voltage drop across the current shunts times the gain of the input and post amplifiers.

**8-14. Current Shunts.** The current shunts are used for ac, dc or dc + ac current measurements. The voltage drop across the shunt resistors is the input voltage to the input amplifier in the milliamps functions.

**8-15. Analog to Digital Converter.** The analog to digital converter uses the *dual slope integration technique* to translate analog input signals into digital timing pulses.

**8-16. Control Logic.** The control logic processes range and function information and provides digital control to MOS FET switches in the input and post amplifiers and the analog to digital converter. The control logic also converts the comparator output (run down time) into appropriate digit and segment drive voltages to operate the display.

**8-17. Display.** The display provides an annunciated digital readout of the input signal using light emitting diodes.

### 8-18. Detailed Theory

**8-19. Power Supply.** Refer to schematic number 5. The

ac secondary voltage from pins 6 and 10 of transformer T700 is full-wave rectified thru CR703 and CR704 and filtered by C703 and C702, to provide an unregulated +12V to pin 7 of U700. U700 and its associated components comprise an adjustable +7V regulator. The regulated +7V output of U700 provides a reference voltage for the -7V regulator and the battery charger voltage regulator. This is true whenever the correct ac line voltage is connected and is irrespective of the power switch (S1).

8-20. The same secondary (pin 6 and 10) is full-wave rectified thru CR705 and CR706 and filtered by C705 to provide an unregulated -12V to the -7V regulator. The -7V regulator consists of U701, Q702, and the associated components. The non-inverting input (pin 3) to OP Amp U701 is grounded. Therefore, the OP Amp will attempt to provide sufficient drive current to the series regulator (Q702), so that the voltage fed back to the inverting input (pin 2) will also be ground (0V). OP Amp quiescence will be reached when the voltage at the emitter of Q702 is equal but opposite to the +7V supply. Figure 8-2 shows a simplified schematic of the -7V regulator.

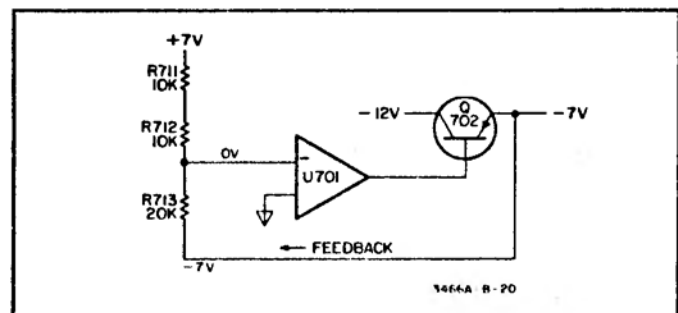

Figure 8-2. -7V Regulator

8-21. The ac secondary voltage from pin 7 and 9 of T700 is full-wave rectified by CR702 and CR701 and filtered by C701 to provide an unregulated +8V to the  $V_{BAT}$  regulation Q802 or Q701 for option 001 instruments (JM700 installed).

### NOTE

*Battery voltage ( $V_{BAT}$ ) will vary between +5.6V and 6.5V depending on the charge status of the battery. The display voltage  $V_{DISP}$  is equal to  $V_{BAT}$  when S1 is ON.*

8-22. The -2.6V ( $V_{SUB}$ ) supply is derived from the -7V regulated supply thru resistive dividers R714 and R715. The  $V_{SUB}$  supply is the *black gate bias* supply to the substrates of U102 (Input Hybrid), U402 (Integrator Hybrid) and U907 (Controller). This supply by itself is not regulated and is therefore, *load sensitive* which is an aid in trouble isolation.

**8-24. 5V Reference Supply.** Refer to Figure 8-3 and schematic number 3. The 5V reference supply consists of reference diode (CR600), OP Amp (U600), and associated

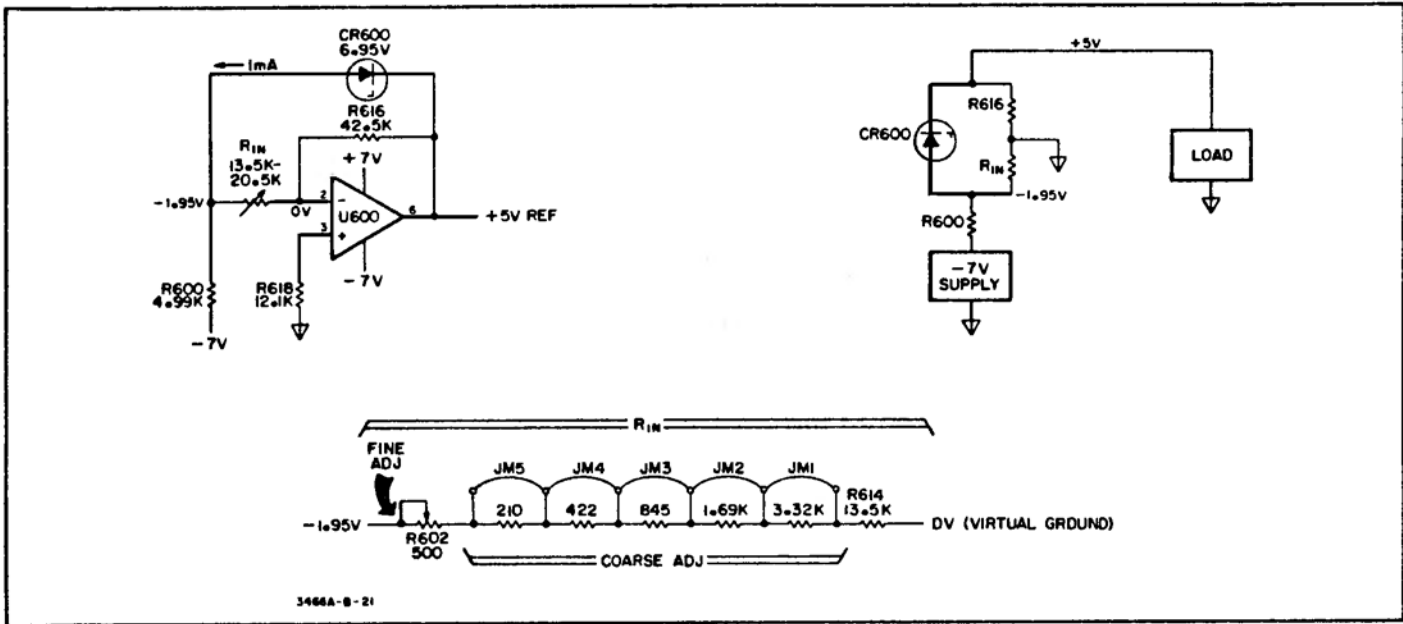

Figure 8-3. 5V Reference Supply Simplified Schematic

resistors. The OP Amp is used to provide a low output voltage source impedance and a virtual ground between R616 and R<sub>IN</sub> as shown in Figure 8-3. The voltage drop across the two resistors (R616) and R<sub>IN</sub> is set by the reference diode to 6.95V. If the junction between R<sub>IN</sub> and R616 is ground and if R616 is a fixed resistance (42.2K), R<sub>IN</sub> can be adjusted to divide the 6.95V reference voltage into 1.95V across R<sub>IN</sub> (negative with respect to ground) and 5V across R616. The result is +5V reference supply that has a low source impedance and is as stable as the reference diode.

8-25. The course R<sub>IN</sub> adjustment is done at the factory and unless the reference diode (CR600) is replaced or some other major repair is performed, R602 will be sufficient to adjust the reference supply. It should also be noted that the reference value, 5V, is not the critical parameter for this adjustment. The adjustment (R602) is made to establish a reference voltage that will allow the integrator and control logic to output a 19.000V display with 19V connected to Multimeter input terminals. This procedure is explained further in Section V, adjustment ①

8-26. The value of R618 is selected to match the impedance of the resistive divider on the inverting (-) terminal of U600. This will balance out bias currents in the OP Amp.

8-27. **Battery Charger and Converter.** Refer to schematic number 5. The battery charger and converter circuitry is located on the A3 PC board. This circuitry has four basic modes of operation:

- Mode No. 1—AC with Multimeter OFF.
- Mode No. 2—AC with Multimeter ON.
- Mode No. 3—Battery charged with Multimeter ON.
- Mode No. 4—Low Battery with Multimeter ON.

8-28. **MODE NO. 1.** In Mode No. 1 (AC with Multimeter OFF), the battery charger is operating at the *fast* charge rate (500mA max). Figure 8-4 shows the simplified schematic of the battery charger circuit. The converter is not operating during this mode.

8-29. The +7V supply is divided across R806, R818, R805, and CR806 thru 810 to provide a reference voltage of approximately 4.3V to the OP Amp regulator (U801A). This reference voltage is adjustable by R818. CR806 thru 810 are used as temperature sensors in the charger reference divider. The diodes have a negative temperature coefficient, which causes the reference voltage to be slightly more positive when the Multimeter is cold than when it has warmed up. Consequently the charge current is also slightly greater when the Multimeter is cold.

8-30. A voltage directly proportional to the battery voltage is monitored at the non-inverting (+) node of U801A. If this voltage is less than the charge reference voltage (U801A inverting node), the OP Amp will output an error voltage. This error voltage will increase the drive to Q801 and Q802 which increases the charge current to the battery. By increasing the current thru the internal resistance of the battery, the voltage drop across the battery is increased; and the proportional voltage that is fed back to the non-inverting node of U801A is also increased. This loop will remain active until the non-inverting node voltage of U801A is equal to the reference voltage at the inverting node.

8-31. R811, U801B and the associated resistors comprise a current limiting circuit for the battery charger. This circuit will decrease the charger reference voltage at U801A if the current thru R811 exceeds approximately 500mA. At 500mA the voltage drop across R811 is 135mV. This voltage is monitored at the inverting input (-) of Op

Amp U801B. The reference for U801B is 134mV which is derived by dividing 7V across R814 and R813. If the voltage at the inverting input is more positive than the voltage of the reference, the OP Amp will output a negative error voltage.

8-32. The negative error voltage must be sufficient to forward bias CR801 before it will effect the charger reference voltage. Therefore, if the polarity of the U801B output voltage is positive; as would be the case if its inverting mode voltage was less than 134mV, CR801 would remain back biased.

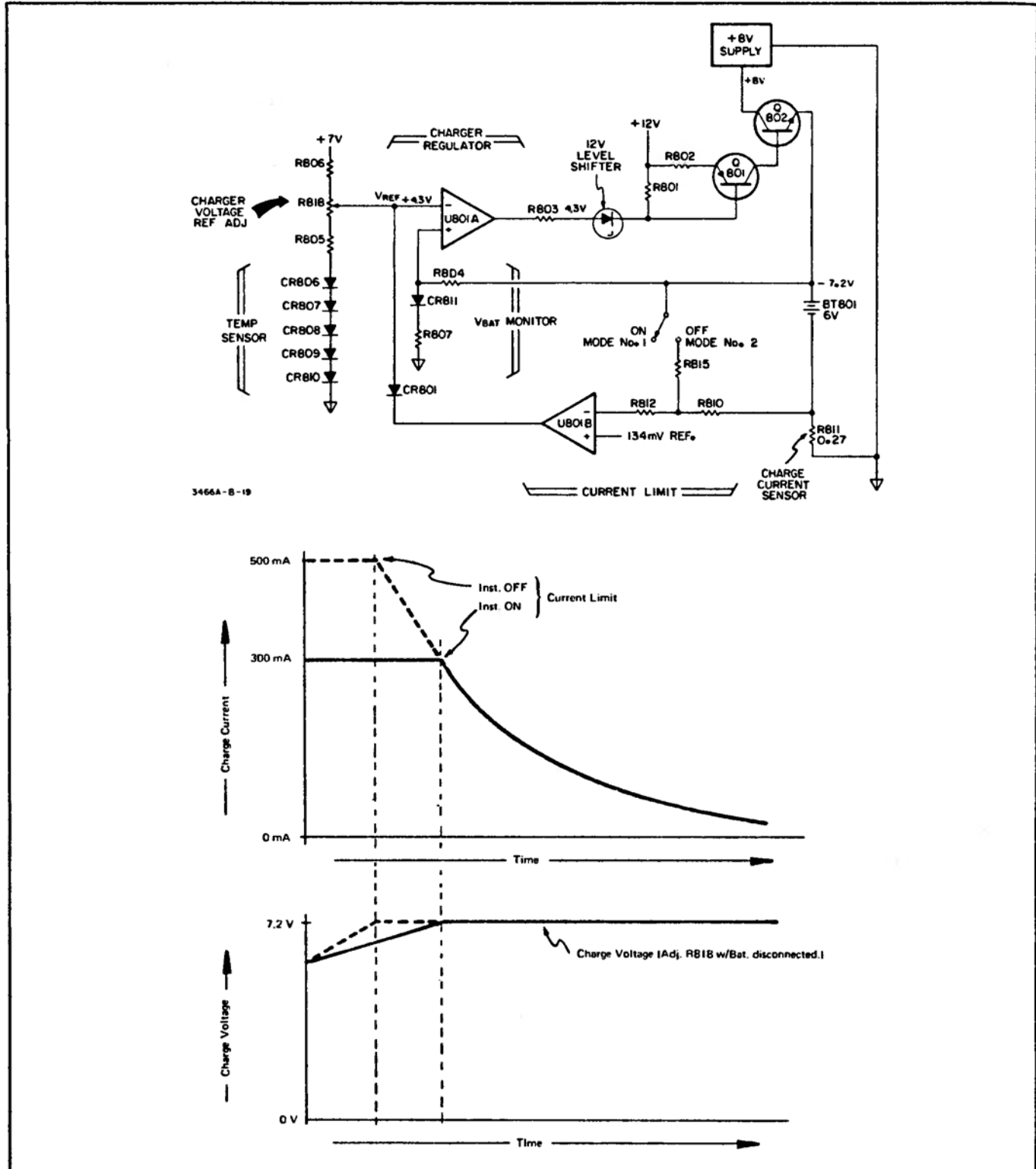

Figure 8-4. Battery Charger

8-33. With a negative error voltage output from U801B, the charger reference voltage is made less positive which decreases the battery charge voltage and current. This decreases the voltage drop across R811 which is the voltage at this inverting input of U801B. This loop will remain active until the output voltage of U801B (cathode of CR801) is more positive than the charger reference voltage (anode) of CR801.

8-34. **MODE NO. 2.** Mode No. 2 (AC with Multimeter ON) is similar to Mode No. 1. Again, the converter is not operating and the batteries are being charged. The battery charging current, however, is limited to 300mA max. instead of 500mA. This is accomplished by connecting the battery charge voltage thru R815 and R810 to the charge current sensor (R811) as shown in Figure 8-4. This biases the inverting node of U801B at approximately 55mV. The voltage drop across R811 need only be an additional 80mV to surpass the reference voltage on U801B (55mV + 80mV = 135mV). An 80mV drop across R811 corresponds to approximately 300mA of charge current.

8-35. **MODE NO. 3.** In Mode No. 3 (Battery Charged with Multimeter ON), the ac line voltage is disconnected, the battery charger is not operating and the Converter is supplying +12V and -12V to the +7V and -7V regulators of the power supply (A1 PC board).

8-36. Three conditions must be met in order to turn the converter on as shown in Figure 8-5. The Power switch (S1) must be on, the battery must be charged above 5.6V and the ac line voltage must be disconnected.

8-37. Input (a) is the battery voltage ( $V_{BAT}$ ) connected thru S1 to U802 pins 3, 4, and 5. Input (b) is the output of U801A as shown in Figure 8-6. This low battery indicator circuit uses many of the same components as used in Mode No. 1. The reference voltage at the inverting node of U801A was approximately 4.3V in Mode No. 1 and No. 2. In Mode No. 3, Q803 is turned on at T1 by the converter control output. This is assuming that the battery is charged. With Q803 turned ON, CR806 thru 810 are effectively shorted out. This changes the reference voltage for U801A (-) to approximately 3.4V.

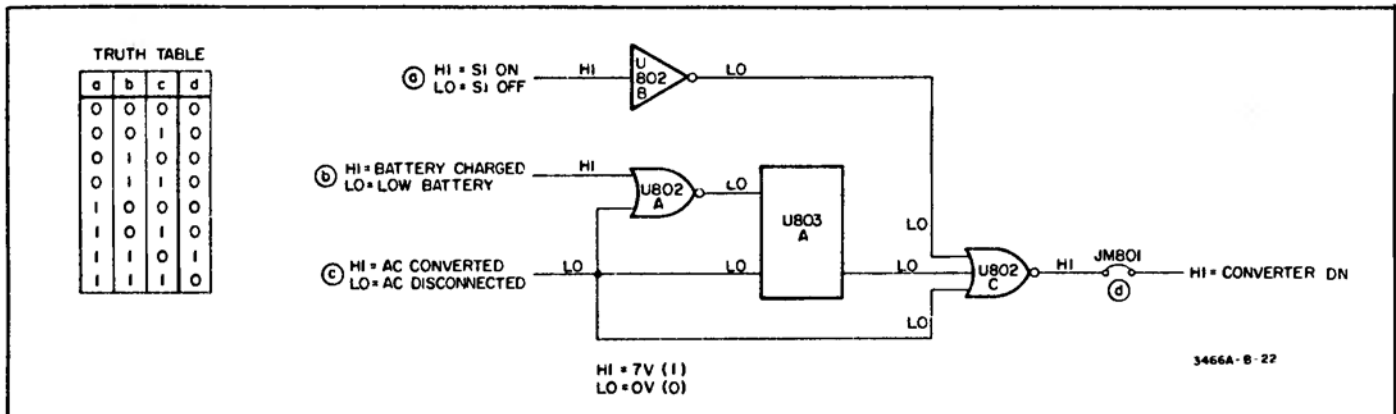

Figure 8-5. Converter Control Logic

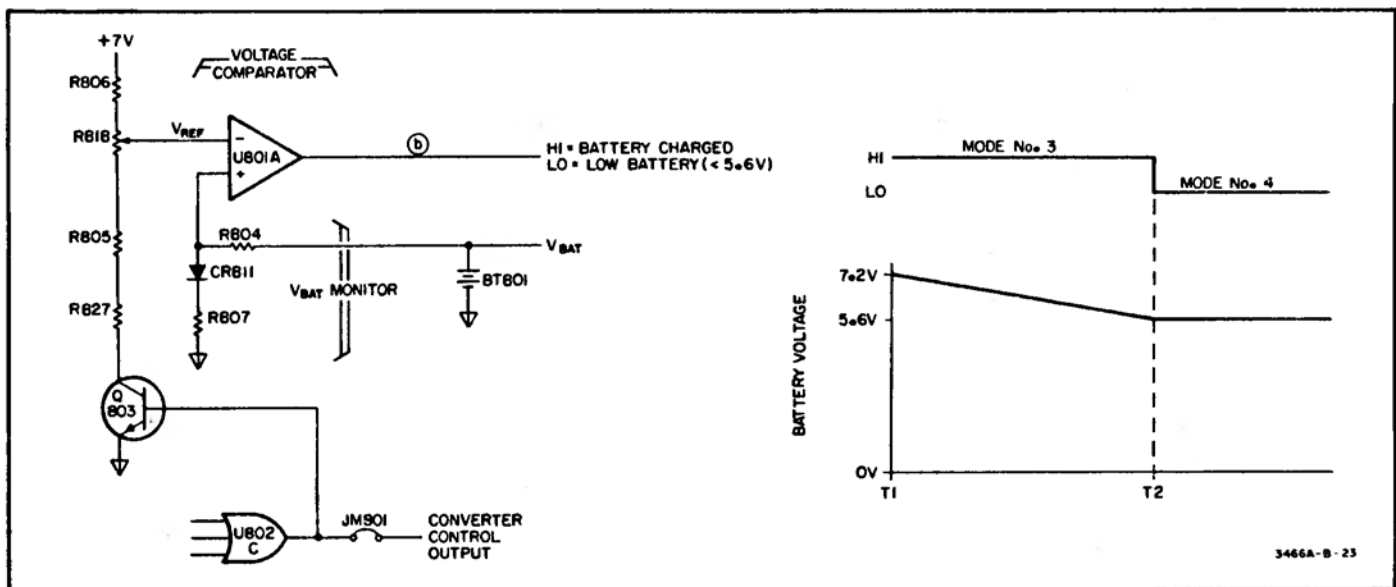

Figure 8-6. Low Battery Indicator

**8-44. Input Switching.** The input switches are separated into two groups — Function (S2 thru S6) and Range (S7 thru S14). The function switches provide correct paths for the input signals to the analog circuitry and at the same time output a three line function code which programs the Digital Control IC (U907), the Input Hybrid (U102), and the Integrator Hybrid (U402). The simplified analog schematic (Figure 8-16) shows the input switching configuration for each function. Table 8-1 shows the three line function codes for each of the seven Multimeter functions.

**Table 8-1. Function Code**

Function	Code		
	FNA	FNB	FNC
DCV (S2)	1	1	0
ACV (S3)	1	0	1
DCV + ACV (S2 and S3)	1	0	1
DCI (S4)	1	0	0
ACI (S5)	0	0	0
DC + ACI (S4 and S5)	0	0	0
$\Omega$ (S6)	1	1	1

**8-45.** The range switches (S7 thru S13) output a three line range code to U902, U102, and U402 when the AUTO (S14) switch is not depressed. If (S14) is depressed, S7 thru S13 are open and the range code information then comes from the Control IC (U907). Table 8-2 shows the range codes and Figure 8-9 shows a block diagram of the logic interface during Auto and Manual ranging.

**Table 8-2. Range Codes**

Range	Code			
	RGD	RGE	RGF	Auto
20mV (S7)	0	1	0	1
200mV (S8)	0	0	0	1
2V (S9)	1	0	0	1
20V (S10)	1	1	0	1
200V (S11)	1	1	1	1
1200V (S12)	0	1	1	1
20M $\Omega$ (S13)	0	0	1	1
Auto (S14)	Open	Open	Open	0

**8-46.** Voltage and ohms functions can be Auto or

Manually ranged. The current function (dcI, acI, and dcI + acI) are manually range only. S8 thru S12 are used to select the correct current shunt for the five current ranges.

**8-47. Analog Theory of Operation**

**8-48. DC Voltmeter.** The Simplified Analog Schematic (Figure 8-16) shows the DC Voltmeter circuit configuration. The function of the analog portion of the Multimeter is to convert voltage, current, or resistance information at the input terminals to a dc voltage at the input to the Analog to Digital Converter (A to D Converter). In the dc voltmeter configuration, the voltage at reference point (B) can vary from 0 Vdc to  $\pm 1200$  Vdc.

**8-49.** The voltage at the input to the A to D Converter (D) needs to stay within the limits of  $-1.9999$  Vdc to  $+1.9999$  Vdc to avoid setting the Multimeter display to an overload (OL) condition. The input voltage (B) must obviously be amplified or attenuated to keep the voltage at (D) within these limits. This is accomplished by the combined gains of the Input and Post amplifiers. Figure 8-10 shows the gain configuration for each of the six dc ranges.

**8-50.** The input voltage at (B) is applied to the input amplifier during integrator run-up only. Consequently, the input voltage to the Input Amplifier is a square wave as shown in Figure 8-10.

**8-51.** In the 20mV and 200mV ranges, K100 is closed and the input amplifier is operated non-inverting. This reverses the polarity of the input voltage to the A to D Converter (D).

**8-52. AC Voltmeter.** The AC Voltmeter circuit configuration is shown in the Analog Simplified Schematic (Figure 8-16). Figure 8-11 shows the gain configuration for each of the five ac ranges.

**8-53.** In the AC Voltmeter configuration the output of the Post Amplifier (D) is the input to the True RMS Converter. This signal will be ac in the ac volts or ac milliamps function. However, in the dc + ac volts or dc + ac milliamps function the voltage at (D) may be acV, dcV, or a combination of both.

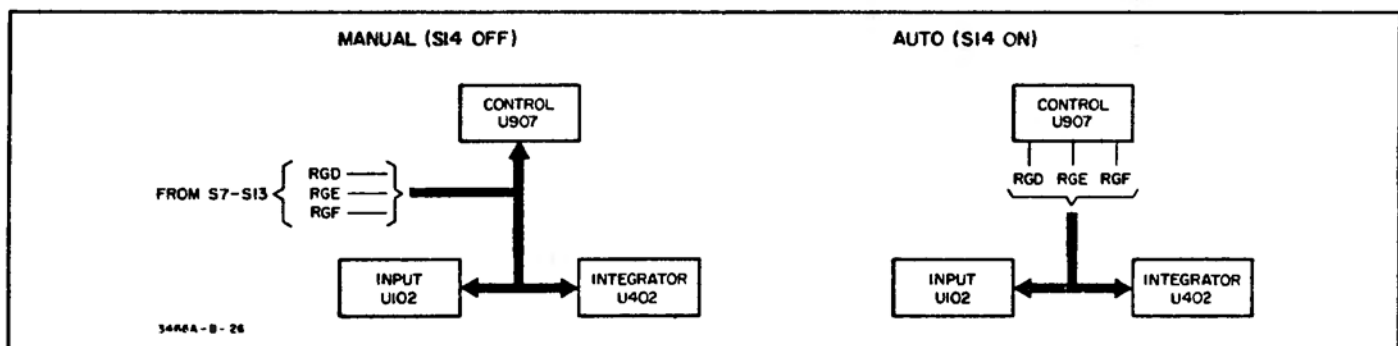

**Figure 8-9. Range Code Logic Interface**

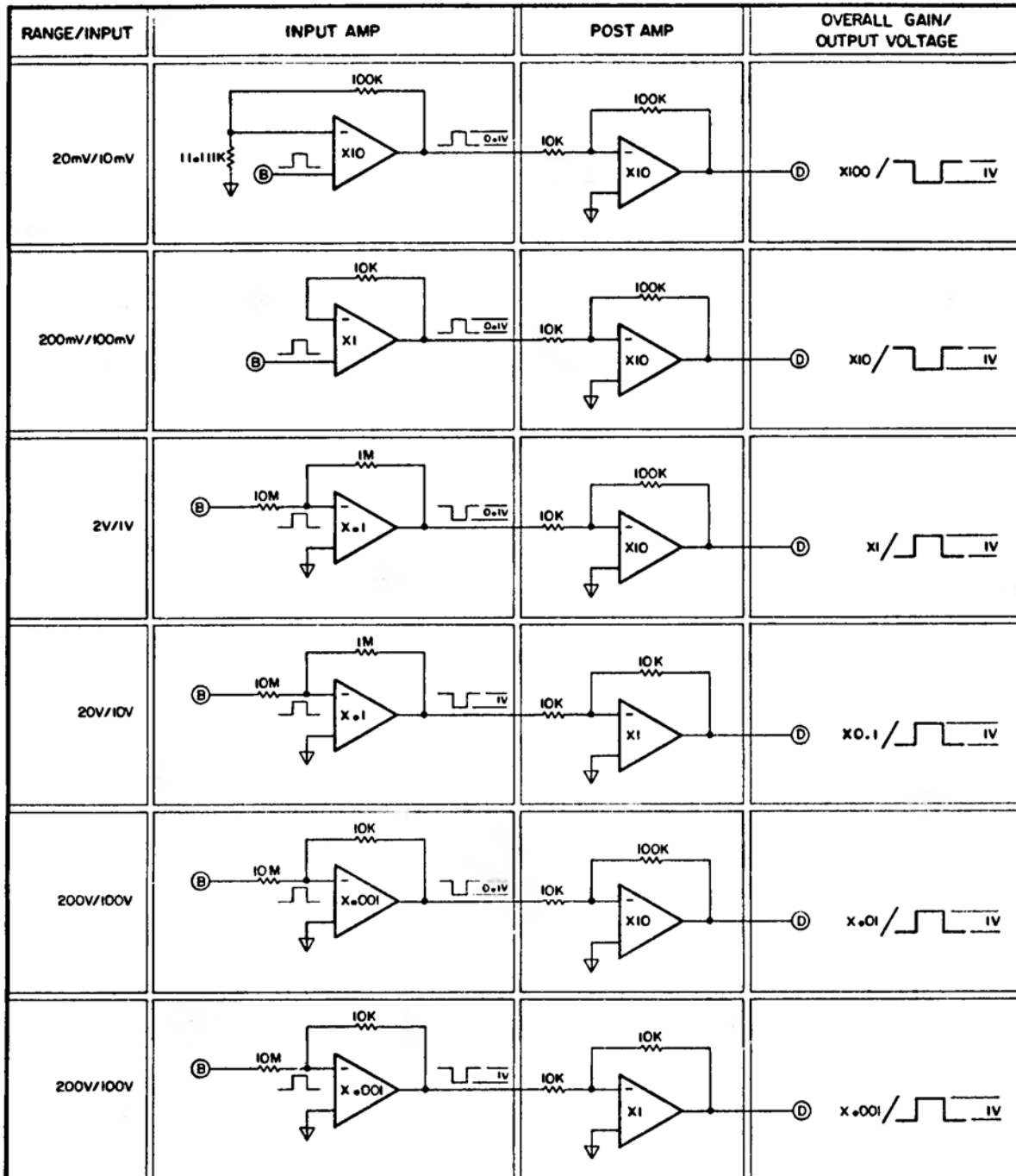

3466A-B-27

Figure 8-10. DC Gain Configuration

8-54. U300 is the True RMS Converter. The output (pin 6) is a dc voltage equal to the true rms value of the input (pin 1). If the input signal was composed of 1 Vac superimposed on 1 Vdc, the output would be 1.414 Vdc which becomes the run-up voltage for the A to D Converter.

**NOTE**

*In some instruments, U300 is replaced with a plug-in PC assembly (A5) which performs the same basic function as U300.*

8-55. Ohmmeter. Refer to the Simplified Analog Schematic for a simplification of the Ohmmeter circuit configuration. Figure 8-12 is a block diagram of the Ohmmeter circuit.

8-56. U500 functions as a low impedance voltage source to  $R_{ref}$ . It outputs 1 volt in the  $2k\Omega$  thru  $20M\Omega$  ranges and .5V in the  $20\Omega$  and  $200\Omega$  ranges. This output voltage is dropped across  $R_{ref}$  to a virtual ground provided by the Input Amplifier (-). The resultant current is the current thru the unknown resistance ( $R_x$ ). Figure 8-13 further simplifies the gain configuration combining the

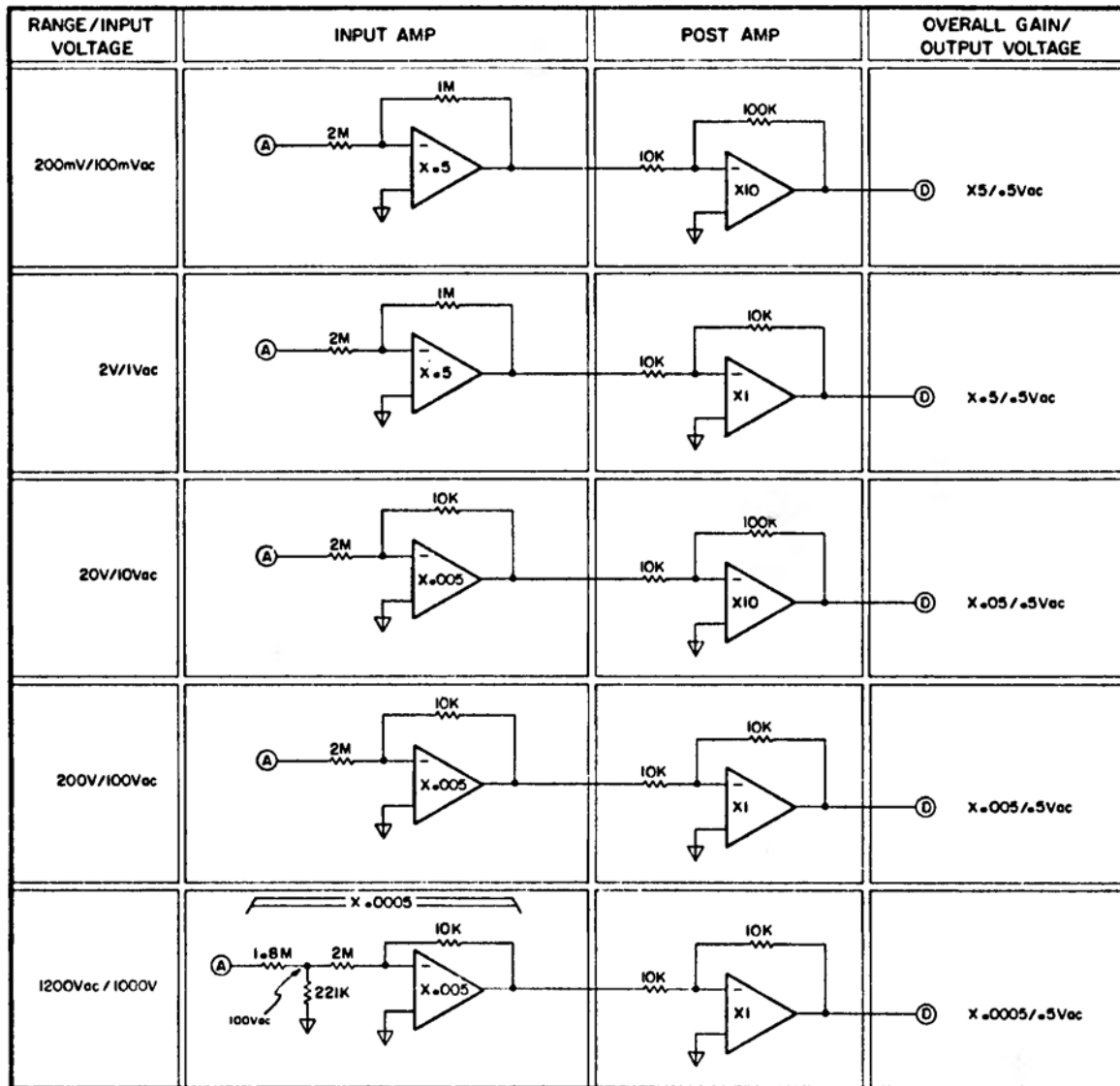

3466A-C-28

Figure 8-11. AC Gain Configurations

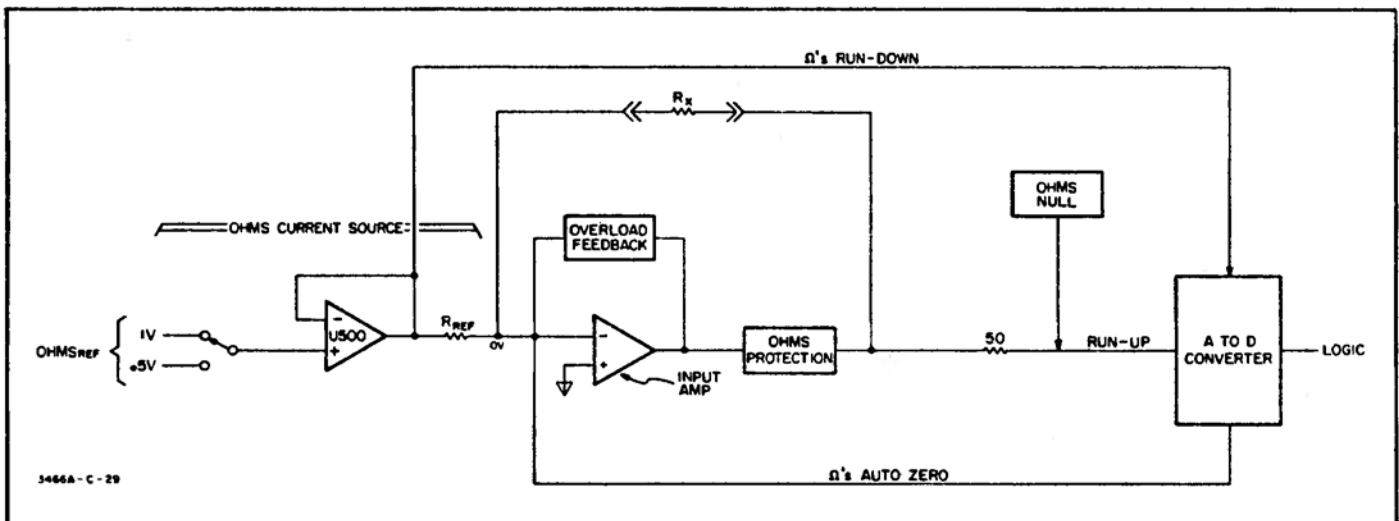

3466A-C-29

Figure 8-12. Ohms Block Diagram



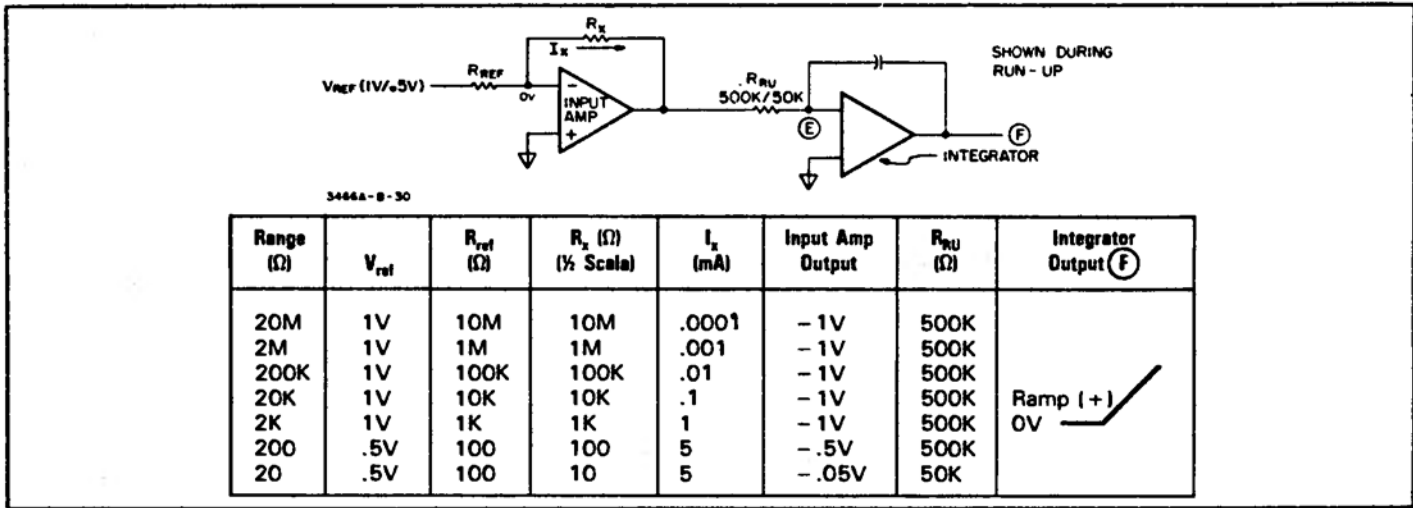

Figure 8-13. Ohm Gain

Input Amplifier, associated compensation, and protection circuitry as an inverting Op Amp with  $R_{ref}$  as the input resistor and  $R_x$  as the feedback resistor. The output of the Input Amplifier is the run-up voltage to the A to D Converter.

8-57. The Ohm's Protection circuit provides protection to the Multimeter circuitry if voltage is inadvertently applied to the ohm's input terminals. A negative voltage is dropped across  $R_{158}$  to the +7V power supply. A positive voltage turns on  $Q_{104}$  and is dropped across  $Q_{102}$  to the 17V power supply.

8-58. The Ohm's Null circuit is enabled in the 20Ω and 200Ω ranges.  $Q_{400}$  is a current source that is adjustable by  $R_{926}$  (Front Panel). With the ohms test leads shorted, the voltage drop across the test lead can be nulled by adjusting  $R_{926}$  in the 20Ω and 200Ω ranges.

8-59. The Ohm's Auto Zero loop compensates for voltage offsets at the input to the Input Amplifier. During auto zero these potential error voltages are stored on the auto zero capacitor ( $C_{408}$ ). During run-up and run-down the voltage on  $C_{408}$  is applied to the Integrator summing junction as a correction voltage.

8-60. Analog to Digital Converter (A to D Converter). The A to D Converter converts dc voltage into a proportional timer control signal. This circuit consists of an Integrator ( $U_{400}$ ), a Slope Amplifier ( $U_{404}$ ), a comparator ( $U_{406}$ ), and an Auto Zero Loop.

8-61. There are four basic conditions ( ① ② ③ ④ ) for a complete measurement cycle as shown in Figure 8-14. These conditions exist for each of the seven Multimeter functions.

8-62. During Auto Zero ①, the exact potential at the Integrator summing junction is stored on  $C_{408}$ . This potential should be nearly zero volts. However, any offset voltages at the input to the Integrator will be stored during condition ①

8-63. At the beginning of run-up ② a dc voltage proportional to the Multimeter input is applied across one of the run-up resistors (depending on the Multimeter function selected). This run-up voltage is integrated across  $C_{402}$ . The polarity of the Integrator output is opposite to the run-up voltage polarity. The run-up voltage polarity is dependent upon the Multimeter function and range selected. Figure 8-14 shows the Integrator output for three different input levels and the polarity for different functions and ranges.

8-64. Run-up is a fixed time of 100 milliseconds. At the end of run-up the run-up voltage is disconnected from the run-up resistor. There is now a 1.6 millisecond hold or settling time ③ before run-down is initiated. During this time the Controller senses the polarity of the Integrator output and selects the proper run-down current. If the integrator output is positive at the end of run-up,  $Q_{H1}$  and  $Q_{H2}$  will be closed during run-down. If the integrator output is negative  $Q_{H1}$  and  $Q_{H2}$  will be open.

8-65. Run-down ④ time may vary from zero to 200 milliseconds depending on the charge built up on  $C_{402}$  during run-up. During run-down the discharge rate of  $C_{402}$  is fixed (fixed slope). Therefore, the greater the charge on  $C_{402}$  (positive or negative), the longer the discharge time. This conversion method from voltage to time is called Dual Slope Integration. A counter is started at the beginning of run-down and runs until the output of the Integrator crosses zero. The accumulated time is directly proportional to the dc voltage at the input to the A to D Converter. This time is processed by the Controller along with the range and function information that is already established, to become the Multimeter display readout.

8-66. The Slope Amplifier and Comparator amplify the output of the Integrator by a factor of X225000. This provides a very accurate zero crossing detector. If the output of the Integrator is positive during run-up, the Comparator output will be positive. This voltage is sensed

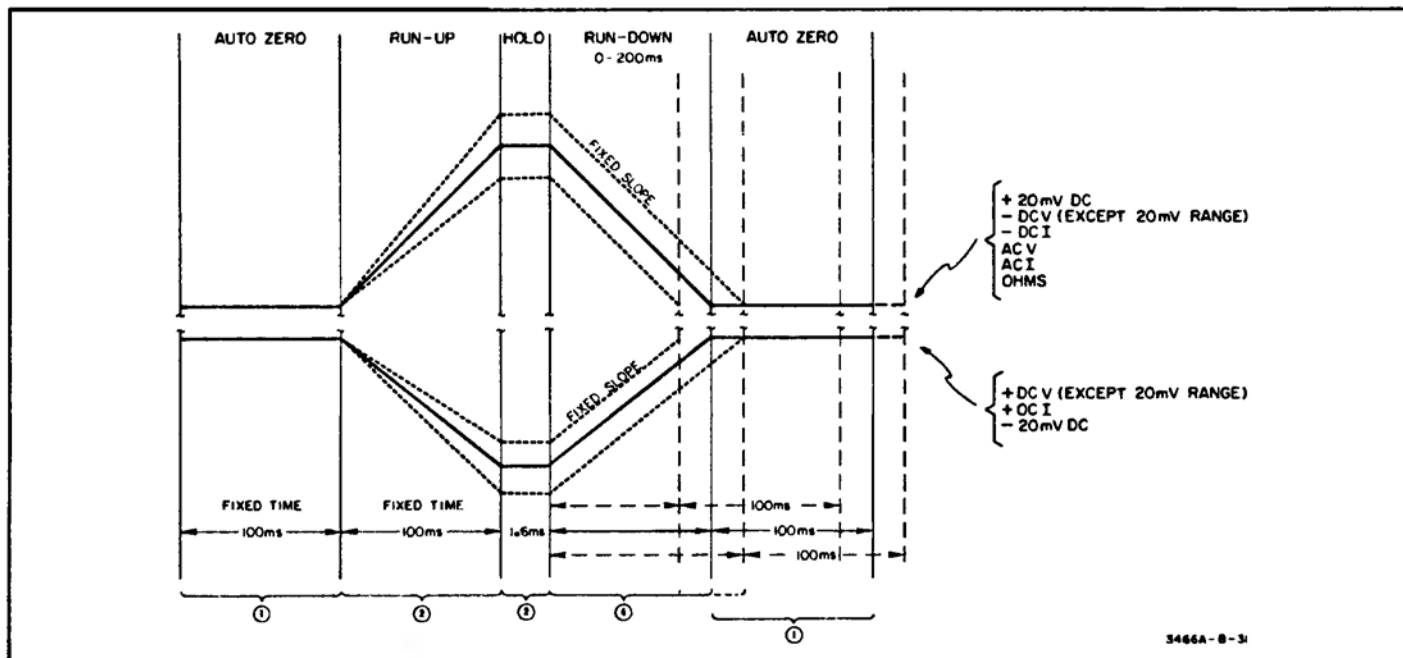

Figure 8-14. Integrator Output

and processed by the controller to provide correct run-down and display information. The comparator will remain positive until the output of the Integrator runs down and crosses zero volts. The comparator then changes to zero volts output.

**8-67. Controller and Logic Interface.** Refer to schematic No. 4 U907 functions as an Algorithmic State Machine (ASM) controller. It controls the MOS FET switching on the Input and Integrator Hybrids. U907 outputs drive signals for the four *most* significant display digits. The least significant digit (LSD) is driven by a separate counter and drive circuit. Figure 8-15 is a block diagram of the Controller and Logic Interface.

**8-68.** At the end of run-down, the output of the A to D Converter (Comparator) is a *state change* HI to LO or LO to HI, depending on the polarity of the Integrator output. As previously discussed, the display counters have been counting since the beginning of run-down. Now, the counters must be stopped exactly as the Comparator state changes to ensure accurate A to D conversion. The comparator output disconnects the 200kHz clock from the divide by ten circuit which stops all counters. The information now stored in the counters is a true representation of the Multimeter Input.

**8-69.** The clock output is disabled for 1 millisecond by one-shot multivibrator U910(7). The comparator input for U907 is delayed .5 milliseconds by one-shot multivibrator U910(9). These time comparisons are shown in Figure 8-15.

**8-70.** When the Controller U907 receives its comparator input (delayed comparator output) the four most significant digits counter is disabled so that when the clock is turned back on the counter information will not change.

Also, at the end of the comparator delay, the information on the LSD clock is latched into U915 for the same reason — so that when the clock is enabled it will not change the counter status.

**8-71.** When the clock is turned back on, the information in the counters is transferred to the display. The counters are then preset to zero and a new measurement cycle begins.

## 8-72. TROUBLESHOOTING

**8-73.** The following paragraphs have the 3466A troubleshooting procedures and other associated information. The paragraphs are separated as follows:

- Equipment Required - paragraph 8-74
- Instrument Disassembly - paragraph 8-76
- General Troubleshooting Information - paragraph 8-78
- Failure Isolation - paragraph 8-80
- Power Supplies Troubleshooting - paragraph 8-85
- Internal Clock Troubleshooting - paragraph 8-94
- Function and Range Select Troubleshooting - paragraph 8-96
- Digital Troubleshooting - paragraph 8-100
- DC Troubleshooting - paragraph 8-106
- Ohms Troubleshooting - paragraph 8-113
- AC Troubleshooting - paragraph 8-121

### CAUTION

*Wear clean cotton gloves when working on the circuit boards or switches. Contamination from finger prints on high impedance points may degrade the performance of the 3466A. Nylon gloves should not be worn due to the possibility of static charge buildup.*



*The hybrid circuits in the 3466A may be permanently damaged by static discharge from a hand or tool when the instrument is disassembled. Follow the following procedure to prevent possible damage.*

1. Ground the hand while disassembling the 3466A. Conductive wristbands (-hp- Part No. 00970-67900) are available for this purpose. It is also suggested to use anti-static bench and floor mats.

2. Attach the 3466A COM terminal to earth ground. Touch all tools to earth ground to remove static charges before using them on the instrument.

3. Use a soldering iron with a grounded tip.

**8-74. Equipment Required**

8-75. The required equipment to troubleshoot the 3466A is listed in Table 8-3. If the recommended equipment is not available, use substitutes that meet the required characteristics.

**8-76. Instrument Disassembly**

8-77. Do the following:

a. Disconnect the 3466A's power cord and turn the instrument off.

b. With the 3466A in the inverted position, locate and loosen the four screws at the bottom of the instrument.

c. Carefully return the 3466A to the upright position with the front panel facing you.

**NOTE**

*The Battery Charger Assembly is located in the top shell assembly and is connected to the main printed circuit assembly by a 9 lead cable. To avoid possible damage to the cable, remove the top shell slowly.*

**NOTE**

*If the battery cable is disconnected, the 3466A will not operate unless JM700 is installed (see paragraph 8-87, step f-3).*

d. Remove the top shell vertically and place it at the right of the bottom assembly in an inverted position. If the battery and battery charger circuitry is installed, make sure the top shell is not lifted up too high.

e. Locate and remove the A4 Assembly's (Logic Board) four mounting screws. Then locate and remove the A2 Assembly's (Display Board) mounting screw.

f. Lift up and remove both sections of plug P902 (on A4 Assembly). Then remove both the A4 and A2 Assemblies without disconnecting them from each other.

g. Place the A4 and A2 Assemblies to the left of the 3466A with the display facing you.

h. Connect the Service Cable (03466-61601) from J102 (on A1 Assembly) to J902 (on A4 Assembly).

**8-78. General Troubleshooting Information**

8-79. Before troubleshooting the 3466A, check the following:

**Table 8-3. Equipment Required**

Instrument Type	Required Characteristics	Recommended Model
DC Voltage Standard	Output: 19mV to 1000V Accuracy: $\pm 0.02\%$	Systron Donner Model M107
AC Calibrator/High Voltage Amplifier	Output: 190mV to 100V Frequency: 200Hz to 100kHz Accuracy: $\pm 0.1\%$ (mid band)	Fluke Model 5200A/5215A
Oscilloscope	Bandwidth: dc to 100MHz Input: .005V to 5V ac/dc Storage Capability	-hp- Model 1741A
Digital Multimeter	Accuracy: $\pm .01\%$ Input Resistance: 10M ohms	-hp- Model 3468A
Resistor Decade Box	Resistors: 1 ohm to 1M ohms Accuracy: $\pm 0.005\%$	General Radio Model GR1433-H
DC Power Supply	Output Voltage: 0 to 20V Output Current: 0 to 2A	-hp- Model 6294A

a. Small offsets in the ac volts function with input shorted is normal and the 3466A should meet its accuracy specifications.

b. Make sure the 3466A is set to the correct power line voltage.

c. Before troubleshooting any ac or ohms failures, make sure the dc volts function is operating correctly. Troubleshoot and repair the dc volts function first.

d. Make sure a nylon screw is used in the center of the top shield to prevent shorting the A4 assembly.

### 8-80. Failure Isolation

**8-81. General.** Unless the 3466A failure is obvious (e.g., a blank display), make sure the instrument is calibrated before doing any troubleshooting (do the Performance Test in Section IV of the manual). Also, since most troubleshooting requires the instrument disassembly, go to paragraph 8-76 for the disassembly procedure.

**8-82.** The 3466A can have two types of failures: Digital and Analog. The Digital Failures can be caused by a defective power supply, the Controller, A/D Converter, or associated circuitry. The Analog Failures are most likely caused by the Input or Post Amplifiers, range and function switches, and associated circuitry. Analog Failures can also be caused by a defective power supply and the digital circuitry (Controller, A/D Converter, etc.). Make sure the power supplies and Controller are good before troubleshooting the instrument. Go to paragraph 8-85 to check the supplies, and paragraph 8-100 to check the Controller and A/D Converter. It is also a good idea to check the 3466A's internal clock operation (see paragraph 8-94).

**8-83. Digital Failures.** The Digital Failures are as follows:

a. **Blank Display** — This failure is most likely caused by the Controller (U907) and associated circuitry. Go to paragraph 8-100 (Digital Troubleshooting) for further isolation.

b. **Display and/or Annunciators Inoperative** — If all the displays and annunciators are inoperative (off or on), the most likely cause is the Controller (U907) and associated circuitry (see previous step). If some of the displays and annunciators are inoperative, use an oscilloscope to check and make sure the display or annunciators receive the correct drive signals (i.e., control lines are toggling; see Schematic 4). If the lines are toggling, try replacing the appropriate display and/or annunciators. If still inoperative, go to paragraph 8-100 (Digital Troubleshooting) for further isolation.

c. **Autoranging Inoperative** — The most likely cause is the Controller (U907). If, however, the failure is noted

only near the autorange limits (19999), the A/D Converter may be defective. Go to paragraph 8-105 (A/D Converter Troubleshooting) for troubleshooting.

**8-84. Analog Failures.** Analog Failures consists of Overload, Constant Zero, Floating, Inaccurate, or Noisy Readings. These failures can be on some or all ranges, and/or on some or all functions. Other analog failures include common-mode rejection and input impedance failures. The failures are explained as follows:

### NOTE

*A Floating Reading is when the 3466A displays what appears to be a normal reading (with no input applied), that is other than zero volts, which does not change after an input is applied to the Multimeter.*

a. **Failures on All Ranges and All Functions** — Except for noisy or inaccurate readings, the failures can be caused by the Input Protection Circuitry, Input and/or Post Amplifiers, or the Digital Circuitry (i.e., the A/D Converter or Controller U907). Go to paragraph 8-100 (Digital Troubleshooting) first and then to paragraph 8-106 (DC Troubleshooting) for troubleshooting. For noisy or inaccurate readings, go to paragraph 8-106 (DC Troubleshooting) for troubleshooting.

b. **Failures on All Ranges in the DC Volts and/or DC Current Functions** — These failures can be caused by the Input and/or Post Amplifiers, or if the incorrect function is selected by the Controller. If only the dc current function is inoperative, try replacing the current fuse first. Then go to paragraph 8-96 to determine if the correct function is selected. If the correct function is selected, go to paragraph 8-106 (DC Troubleshooting) for troubleshooting.

c. **Failures on All Ranges in the Ohms Function** — Make sure the dc volts function is operating correctly before troubleshooting the ohms function. If the dc volts function is good, ohms failures can be caused by the Ohms Protection Circuitry, Input and/or Post Amplifiers, Ohms Current Source, or if the incorrect function is selected by the Controller. Go to paragraph 8-96 first to determine if the correct function is selected and then go to paragraph 8-113 (Ohms Troubleshooting) for troubleshooting.

d. **Failures on All Ranges in the AC Volts and/or AC Current Functions** — Make sure the dc volts function is operating correctly before troubleshooting the ac volts/current functions. If the dc volts function is good, ac failures can be caused by the Input and/or Post Amplifiers, RMS Converter, or if the incorrect function is selected by the Controller. Go to paragraph 8-96 first to determine if the correct function is selected and then go to paragraph 8-121 (AC Troubleshooting) for troubleshooting.

**e. Failures on Some Ranges in Some or All Functions**— These failures can be caused by defective range or function switches, the Controller, or the Input and/or Post Amplifiers. First go to paragraph 8-96 to determine if the switches are good. Then go to paragraph 8-106, 8-113, or 8-121 if the failures are noted in the dc volts or dc current, ohms, or ac volts or ac current functions, respectively.

**f. Input Impedance Failure** — This failure usually shows up when a high impedance source is connected to the 3466A's input terminals, and if the 3466A is on the 2V and above range. Check for a shorted K100 and make sure the relay is not turning on Q100 and associated circuitry (see Schematic 2).

**g. Common-Mode Rejection Failure** — Make sure the spring at the bottom of the A1 assembly makes good contact with the bottom shield. Also make sure there is a good connection between the power transformer frame and earth ground. Tighten the screws, if necessary.

**8-85. Power Supplies Troubleshooting**

8-86. Unless otherwise noted, refer to Schematic 5 for the following troubleshooting information. The 3466A has three regulated power supplies, +7V, -7V, and -2.6V, and a +6.3V battery supply. The regulated supplies are developed by the +15V and -15V Unregulated supplies (when ac power is connected to the 3466A) or by the +12V and -12V Unregulated supplies (during battery operation). The +12V and -12V supplies are developed by the Battery Charger Assembly (A3).

8-87. Use the test Digital Multimeter and test oscilloscope to check and troubleshoot the power supplies and Battery Charger Assembly. Check the power supply voltages at the +7, -7, and -2.6 pads with both ac power connected and disconnected from the 3466A. Check the supplies as shown in Table 8-4. Make sure the instrument is turned on when checking the supplies. The power supplies failures are as follows:

**Table 8-4. Power Supply Voltages**

Test Pad	Voltage
+7V	+6.9V to +7.1V
-7V	-6.9V to -7.1V
-2.5V	-2.3V to -2.7V
+6.3V	+5.6V to +7.2V

**a. All Supplies Fail with AC Power Disconnected.** Troubleshoot the Battery Charger (A3) Assembly (go to paragraph 8-88).

**b. All Supplies Fail with AC Power Connected or Disconnected.** Troubleshoot the +7V power supply. This is necessary since the +7V supply is used as the reference supply for the others. Do the following:

1. With ac power connected to the 3466A, turn the instrument off (S1 in OFF position).
2. Measure the +7V power supply at pin 6 of U700.
3. If the +7V supply is good with the 3466A turned off, other circuitry in the 3466A may be loading down the supply. Continue with step 6.
4. If the +7V supply fails, measure the +15V, -15V, and -10V Unregulated supplies.
5. If any supply fails, troubleshoot T700, CR701 to CR706, and associated circuitry. If the supplies are good, troubleshoot U700 and associated circuitry. Since an excessive output current can damage U700, make sure other circuitry in the 3466A is not loading down the supply before turning on the instrument. Continue with the next step.
6. With the 3466A turned off, connect an external +7V power supply to the TP +7 pad and measure the supply's output current (use the meter on the supply itself or use an external test multimeter).
7. If approximately 21mA or less is drawn from the supply, the other circuitry is good. Troubleshoot U700 and associated circuitry only if the +7V supply is defective with the 3466A turned on and good with the instrument turned off.
8. If excessive current is drawn (i.e., much more than approximately 21mA), the other circuitry in the 3466A is loading down the supply. Remove the A4 assembly from the instrument. If the current is now good, the digital circuitry on the A4 assembly is causing the failure. If the current is still too high, the analog circuitry on the A1 assembly is causing the failure.
9. The defective component(s) can be isolated by measuring the voltage drop across the traces (on the A1/A4 boards) that connect the +7V supply to the various components. Make sure the 3466A is turned off, the external +7V power supply is used, and the test meter is set to the dc volts function. The trace with the highest voltage drop across it is the one that is most likely connected to the shorted component.

**c. The +7V Supply is Good, and the -7V and -2.6V Supplies Fail.** Do the following:

1. With ac power connected to the 3466A, turn the instrument off (S1 in OFF position).
2. Measure the -7V power supply at the emitter of Q702.
3. If the supply still fails, troubleshoot U701, Q702, and associated circuitry.

**d. Only the  $-2.6\text{V}$  Supply Fails.** Make sure C710, R714, and R715 are good. If they are, the supply may be loaded down by other circuitry. Isolate the defective circuitry by doing the following (see Schematic 3):

1. Remove the A4 assembly. If the  $-2.6\text{V}$  supply is now good, replace U907. If still defective, keep the A4 assembly removed.
2. Remove hybrid U102. If the  $-2.6\text{V}$  supply is now good, replace U102.
3. If the  $-2.6\text{V}$  supply is still inoperative, replace U402.

#### NOTE

*If a static discharge had occurred in the instrument, more than one hybrid may be defective (e.g., U402, U907, etc.).*

**e. The  $+6.3\text{V}$  Supply Fails.** The battery may be defective or discharged. Go to paragraph 8-88 for troubleshooting.

**f. The  $+7\text{V}$ ,  $-7\text{V}$ , and  $-2.6\text{V}$  Supplies are All Good.** Do the following:

1. Make sure the 3466A is turned on (S1 in ON position) and ac power is connected.
2. Disconnect the A3 Assembly (Battery Charger Assembly) from the A1 Assembly.
3. Temporarily connect the emitter of Q701 to the  $+6.3$  pad (battery voltage pad) located next to P701. This replaces jumper JM700 used in option 001 instruments.
4. If the instrument now operates, the Battery Charger circuitry may be defective. Go to paragraph 8-88 for troubleshooting.
5. If the instrument is still inoperative, with the emitter of Q701 connected to the  $6.3$  pad, the power supplies are not at fault. Troubleshoot the other circuitry in the 3466A (go to paragraph 8-80).

### 8-88. Battery Charger Assembly Troubleshooting

**8-89. General.** The Battery Charger Assembly has three major sections: a Battery, Battery Charger, and Converter. These sections are explained as follows:

**a. Battery.** Used as the power supply for the display and the Converter when ac power is disconnected.

**b. Battery Charger.** This circuit charges the Battery when ac power is connected and has two parts to it: Voltage Regulator and Charger Current Limit circuits.

**c. Converter.** This circuit develops the  $+12\text{V}$  and  $-12\text{V}$  Unregulated power supplies when ac power is disconnected and has four parts to it: Converter Control Logic, Converter Oscillator, Oscillator Pulse Shaper, and AC to DC Converter.

8-90. The following paragraphs have the Battery Circuitry and Battery Charger Circuitry failures and troubleshooting information. Refer to Schematic 5 for the following.

**8-91. Instrument Inoperative (Blank Display) with AC Power Connected.** This failure can be caused by the Converter, or low voltage or an open circuit from the Battery. Do the following (refer to Schematic 5):

a. Make sure ac power is connected to the instrument.

b. Using the test oscilloscope, measure for any signals at the junctions of diodes CR814 and CR815, and CR812 and CR813 (see Schematic 5).

c. If no signal is measured, continue with step d. If any signal is measured, the Converter circuitry is at fault. Do the following:

1. Using the test multimeter, measure for approximately zero volts at JM801.

2. If the voltage is good, troubleshoot for a defective U803 and U804.

3. If the voltage is high (i.e., battery voltage), use information on the schematic to check for a defective CR804, U802, or U803.

d. Remove any of the two wires from the battery.

e. Measure the voltage at the  $+6.3$  pad. The voltage should be  $>5.6\text{V}$  or  $7.2\text{V}$ .

f. If the voltage is incorrect, troubleshoot the Battery Charger.

g. If the voltage is good, check for an open F801 and R811. Also make sure the Battery Charge Voltage Adjustment can be performed (see Section V). If unable to adjust to the correct charging voltage, lift one end of CR801. If adjustment is now possible, troubleshoot U801B and associated circuitry. If still unable to adjust, troubleshoot U801A and associated circuitry.

**8-92. Instrument Temporarily Turns On and Then Off with AC Power Disconnected.** This failure can be caused by the Turn-On Circuit (i.e., Converter Control Logic) used to turn on the Converter (i.e., Converter Oscillator). The Turn-On Circuit, if malfunctioning, may only temporarily turn on the oscillator. To troubleshoot this circuit, do the following:

a. Turn the 3466A off.

- b. Connect a 1M ohm resistor across C805.
- c. With ac power disconnected, turn the 3466A on.
- d. If the 3466A turns on and stays on, try replacing C805.
- e. If 3466A does not turn on or stay on, troubleshoot U802, U803, and associated circuitry.

**8-93. Instrument Inoperative (Blank Display) with AC Power Disconnected.** This failure can be caused by low battery voltage, Converter Control Logic, or by the Converter circuitry. Do the following:

- a. Use the test Digital Multimeter to make sure the battery voltage is above 5.6V. Check the Battery Charger circuitry or the Battery, if low.
- b. Turn the 3466A on with ac power disconnected and make sure JM801 is high. Troubleshoot the Converter Control Logic if low.
- c. Use the test oscilloscope to check the signal, shown on Schematic 5, at the collectors of Q804 and Q805.
- d. If the signal is missing, the Converter Oscillator and Oscillator Pulse shaper circuitry may be defective. Do the following:
  1. Check at JM801 if there is enough drive for transistors Q804 and Q805.
  2. If there is enough drive signal, try replacing Q804 or Q805.
  3. If there is no signal at JM801, trace back to the Converter Oscillator to determine if U803 or U804 are defective (use information on the schematic to determine the signals developed by U803 and U704). (The signal from the Converter Oscillator is approximately 50kHz.)
- e. If the signals at Q804 and Q805 are good, check the signal at CR814 and CR815, and CR812 and CR813, as shown on the schematic.
- f. If the signals are missing, check for a defective CR812 to CR815, or T801.

#### 8-94. Internal Clock Troubleshooting

8-95. Refer to Schematic 4. Do the following:

- a. Use the test oscilloscope to check the clock signal at the CLK jumper on the A4 Assembly. The signal should be a 7V, 200kHz square wave.
- b. If the frequency is wrong, try replacing Y900.
- c. If the signal is missing or low, lift jumper CLK and

check the signal at pin 6 of U909. If the signal is now good, U913 may be loading it down.

- d. If the signal is still low or missing, troubleshoot U909, Y900, and associated circuitry.

#### 8-96. Function and Range Select Troubleshooting

8-97. The following paragraphs have troubleshooting procedures to check the function and range switches.

**8-98. Function Select Troubleshooting.** Do the following:

- a. With the 3466A turned on, set the instrument to the function that fails. If all functions fail, set the instrument to the dc volts function.
- b. Check the state of the function control lines (FNA, FNB, and FNC) at J902, pins 5, 4, and 3 for the FNA, FNB, and FNC lines, respectively. Make sure the lines are in the correct state as listed in the function table on Schematic 1.

- c. If they are in the correct state, the function switches are good. Go to paragraph 8-106, 8-113, or 8-121 for the dc volts or dc current, ohms, or ac volts or ac current troubleshooting procedures, respectively.

- d. If the lines are in the wrong state, troubleshoot the function switches.

**8-99. Range Select Troubleshooting.** Do the following:

- a. With the 3466A turned on, set the instrument to the defective range.
- b. Refer to the range table on Schematic 1 and determine the state of the Range Code Lines (RGD, RGE, RGF, and Auto). The lines can be checked at J902, pins 12, 14, 15, and 16 for the RGD, RGE, RGF, and AUTO lines, respectively.

- c. If they are in the correct state, the range switches are good. Go to paragraph 8-106, 8-113, or 8-121 for the dc volts or dc current, ohms, or ac volts or ac current troubleshooting procedures, respectively.

- d. If the lines are in the wrong state, troubleshoot the range switches.

#### 8-100. Digital Troubleshooting

**8-101. General.** Unless otherwise noted, refer to Schematics 3 and 4 for the following explanation and troubleshooting information. The digital circuitry consists of a Controller (U907), Display and Annunciators (A2 Assembly), A/D Converter and associated circuitry. The Controller controls the operation of the A/D Converter, enables the relays and FET switches (for the different functions and ranges), and sends data to the display.

8-102. Troubleshoot the 3466A by placing the instrument into the Self-test mode (see paragraph 8-101) and then checking the operation of the Controller (see paragraph 8-104).

**8-103. 3466A Self-Test.** This test, also called the "8000 Count Test", can be used to check the operation of the Controller (U907) and associated circuitry, the display, and A/D Converter. To select the test, do the following:

a. Turn the 3466A off.

b. Refer to Figure 8-15 and connect the test jumper to the test position, as shown in the figure. If the 3466A is an older instrument that does not have the test jumper, do the following:

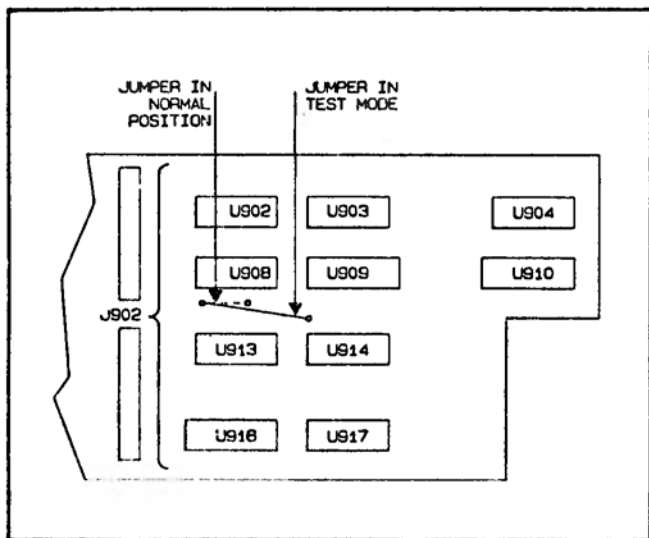

**Figure 8-15. 3466A Self-Test Connection**

1. Unsolder and remove the comparator jumper located between U908 and U913.

2. Solder a one inch insulated jumper between the comparator jumper hole nearest U908 pin 4 and the test pad adjacent to U914 pin 14.

3. The 3466A's test mode can now be selected.

c. Turn the 3466A on. The 3466A should now be in the test mode.

d. To return the 3466A to normal operation, replace the jumper to its original position. For older instruments, place the test jumper in place of the original comparator jumper.

**8-104. Digital Circuitry Troubleshooting.** Troubleshooting the digital circuitry is accomplished by placing the 3466A into the test mode and then making the measurements listed in Table 8-5. Do the following:

a. Turn the 3466A off.

b. Place the 3466A into the test mode (see paragraph 8-103).

c. Turn the 3466A on. The display should now show "800X" (the least significant digit may change from instrument to instrument).

d. If the display shows "800X", the display circuitry is most likely good. Further checks are required as follows:

1. With the 3466A in the test mode, set the instrument to the dc volts function and the 2V range.

2. Apply +1V dc to the 3466A's input terminals.

3. Use the test oscilloscope to check each pin on J902 against the readings shown in Table 8-5. Use the scope's storage capability to display the readings.

4. If all the readings are good, the digital circuitry is most likely good. Go to the dc, ohms, or ac troubleshooting paragraphs (paragraphs 8-106, 8-113, or 8-121, respectively).

5. If the reading on pin 6 is incorrect, the A/D Converter is most likely at fault. Go to paragraph 8-105 for troubleshooting.

6. If the reading on pin 11 is incorrect, check for a defective counter U912.

7. If the reading on any of pins 8 to 10, 19, and 23 to 25 on J902 are incorrect, the Controller is most likely at fault. Before replacing the controller, make sure other circuitry is not loading it down. To verify this, bend the associated pin on J902 up to disconnect it from U907 and check the reading again. If the reading is now good, check the other circuitry.

8. If the readings on any of pins 3 to 5, 12, and 14 to 16 are wrong, troubleshoot the range and/or function switches (go to paragraph 8-96).

9. If the reading on pin 18 is wrong, troubleshoot the Reading Hold Buffer Circuitry (see Schematic 1).

e. If the first three digits on the display are "800" and the least significant digit is missing or wrong (i.e., other than a number is shown), check the least significant digit circuitry (U901, U903, U905, U911, U912, U915, U916, and DSM5).

f. If the reading on the display is other than "800X", an overload (OL), or missing, either the 3466A is unable to go into its Self-test, or the Controller and/or the Display is defective. Do the following:

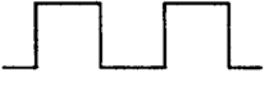
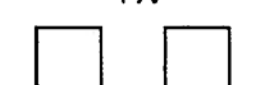
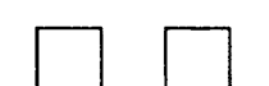
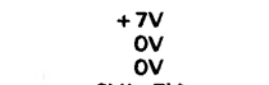
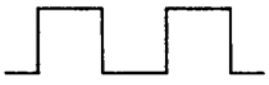

**Table 8-5. 3466A Self-Test (+1V Input)**

J902 Pin Number	Scope Reading	Description
1	0V	DISP GND
3	0V	FNC (Function Code Line C)
4	+7V	FNB (Function Code Line B)
5	+7V	FNA (Function Code Line A)
6	 +6V 0V	Comparator
8	 +7V 0V	Ramp + (RMP)
9	 +7V 0V	Ramp - (RMP)
10	 +6V 0V	Run-Up Enable (RUE)
11	 +6V 0V	Run-Up Clock, 10kHz (RUC)
12	+7V	RGD (Range Select Code D)
14	0V	RGE (Range Select Code E)
15	0V	RGF (Range Select Code F)
16	0V/+7V	Auto/Manual
18	+7V	External Hold
19	 +6V 0V	Auto Zero Logic (AZL)
23	+7V	Q106A/B Control
24	0V	Q106A/B Control
25	0V	Reed Drive

1. With the 3466A in the test mode, make sure the 10kHz clock is good (see paragraph 8-94).
2. Check for toggling at the COMPARATOR jumper.
3. If no toggling is noted, check for toggling at pin 9 of U907 (RUC). If toggling is noted, check for a defective U902. If no toggling is noted, check for a defective U907.
4. If the COMPARATOR jumper toggles and the reading on the display is an overload, check the pins on J902 against the readings listed in Table 8-5 (see step d-1).
5. If the COMPARATOR jumper toggles and the reading on the display is missing, the display is incorrect (shows other than numbers), or the display is locked up (no change noted), check the rest of the digital circuitry. Use signals shown on the schematic for troubleshooting; make sure the signals are at the correct levels (approximately 0 and 7V).

**8-105. A/D Converter Troubleshooting.** Make sure the Controller (U907) and associated circuitry is operating

correctly (see paragraph 8-104) before troubleshooting the A/D Converter. Troubleshooting the A/D Converter is accomplished by placing the 3466A into the test mode and then making some critical measurements. Do the following (refer to Schematic 3):

- a. Turn the 3466A off.
- b. Place the 3466A into the test mode (see paragraph 8-103).
- c. Turn the 3466A on.
- d. Set the 3466A to the dc volts function and the 2V range.
- e. Apply +0.8V dc to the 3466A's input terminals.
- f. Use the test oscilloscope to check the reading at JM201. Compare with the signal shown in Table 8-6. Use the scope's storage capability to display the reading.

**NOTE**

*Jumper JM201 may be marked J201 on the printed circuit board.*

Table 8-6. A/D Converter and Amplifiers Waveforms

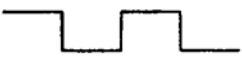
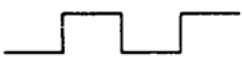
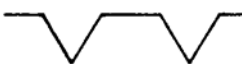
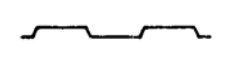
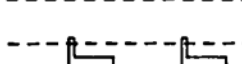
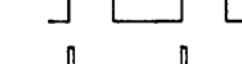
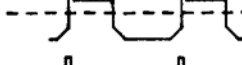
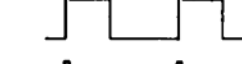
Test Point	Scope Reading
JM101	 0V - .8V
JM201	 +.8V 0V
Integrator Output (U400 pin 6)	 0V - 1.8V
U404 pin 3	 +7V 0V
U404 pin 15	 0V - 6.5V
U404 pins 6, 8	 +.8V 0V - 1.2V
U406 pin 10	 0V - 6V
U406 pin 1	 0V - 5.4V

g. If the reading is missing or incorrect, the Post Amplifier output is incorrect. Go to paragraph 8-106 (DC Troubleshooting) for troubleshooting.

h. If the reading is good, take the reading at the Integrator Output (U400 pin 6). Compare with the signal shown in Table 8-6.

i. If the signal is missing or wrong, the Integrator (U400) or Integrator Hybrid U402 may be defective. Do the following:

1. Connect a short across the Integrator Capacitor (C402) to change the Integrator (U400) to a X1 gain amplifier. Then measure the Integrator output (U400 pin 6) again.
2. If the output is approximately 0V, the Integrator is most likely good. Check for a defective C401 or U402.
3. If the voltage is other than 0V, troubleshoot U400 and associated circuitry.

### 8-106. DC Troubleshooting

8-107. DC failures can consist of dc volts and/or dc current function failures on some or all ranges. The following are the failures and troubleshooting information.

#### NOTE

*Jumpers JM101 and JM201 may be marked J101 and J201, respectively, on the printed circuit board.*

8-108. Overload, Floating, or Constant Zero Readings on All Ranges in the DC Volts Function. This failure can be caused by the Input and/or Post Amplifiers, or by the A/D Converter. Do the following:

a. If the failure is a Floating or Constant Zero Reading, continue with step b. If the failure is an Overload, do the following:

1. Set the 3466A to the dc volts function and the 2V range.

2. Using a short clip lead, temporarily connect JM201 to ground.

3. If the overload remains, the A/D Converter or the digital circuitry is most likely at fault. Continue with step b.

4. If the overload disappears, remove the clip lead from JM201 and connect it to JM101.

5. If the 3466A now shows an overload, troubleshoot the Post Amplifier (U200 and associated circuitry).

6. If no overload is displayed, troubleshoot the Input Amplifier (U100 and associated circuitry).

b. Turn the 3466A off.

c. Place the 3466A into the test mode (see paragraph 8-103).

d. Turn the 3466A on. The display should now show "800X" (the least significant digit may change from instrument to instrument).

e. If the display is wrong, the failure is in the digital circuitry. Go to paragraph 8-100 for troubleshooting.

f. If the display is correct, make sure the 3466A is set to the dc volts function and the 2V range.

g. Apply +0.8V dc to the 3466A's input terminals.

h. Use the test oscilloscope to check the reading at JM201 (see Schematic 3). Compare with the signal shown in Table 8-6. Make sure the reading is not oscillating. Use the scope's storage capability to display the reading.

i. If the reading is good, the A/D Converter may be defective. Go to paragraph 8-105 for troubleshooting.

j. If the reading is wrong, the Input and/or Post Amplifiers are defective. Do the following:

1. Use the test oscilloscope to check the reading at JM101. Compare with the signal shown in Table 8-6. Make sure the reading is not oscillating.

2. If the reading is good, the Post Amplifier, U402, and associated circuitry are defective. Before troubleshooting the amplifier, make sure U300 is not causing the failure. Lift jumper JM200 and check the reading again. If now good, replace U300. If still wrong, troubleshoot the Post Amplifier circuitry.

3. If the reading at JM101 is wrong, apply +1V dc to the 3466A's input terminals. Use the test Digital Multimeter to check for +1V at U102 pin 21 (see Schematic 2).

4. If the voltage at U102 pin 21 is good, the Input Amplifier, U102, and associated circuitry are defective. Before troubleshooting the circuitry, lift jumper JM101 (see Schematic 3). If the output of the Input Amplifier is now good (i.e., 0 to -1V square wave), U402 may be loading down the amplifier. If the reading is still wrong, troubleshoot the Input Amplifier circuitry.

5. If the voltage at U102 pin 21 is wrong or missing, use the test Digital Multimeter to trace the +1V voltage from the input terminals to U102 pin 21 (see Schematics 1 and 2). Check for open circuitry.

**8-109. All Ranges in the DC Volts Function are Inaccurate.** Refer to Schematics 2 and 3. Before troubleshooting for inaccurate readings, make sure the 3466A's 5V reference supply is good. Also check for an oscillating Input Amplifier. Replace U100 if oscillating. If the reference supply is good and the Input Amplifier is not oscillating, the failure can be caused by small offsets and gain errors in the A/D Converter, or the Input or Post Amplifiers. This is normally caused by small offsets and gain errors. Do the following:

a. Set the 3466A to the ac volts + dc volts function. (Simultaneously press the front buttons for the dc volts and ac volts functions.)

b. Set the 3466A to the 200mV range.

c. Apply +100mV dc to the 3466A's input terminals.

d. Using the test Digital Multimeter, measure for +100mV at JM101 (see Schematic 3).

e. If the voltage is good, continue with step f. If the voltage is wrong, check the following:

1. Make sure the voltage at pin 21 of U102 is +100mV (see Schematic 2).

2. If the voltage is good, troubleshoot U100 and associated circuitry.

3. If the voltage is wrong, troubleshoot the input switching and protection circuitry.

f. Measure for -1V dc at JM201.

g. If the voltage is wrong, troubleshoot U200 and associated circuitry.

h. If the voltage is good, the A/D Converter is at fault. Try replacing C402.

**8-110. All Ranges in the DC Volts Function are Noisy.** Check the following:

a. Make sure the power supplies are not noisy. Also check for defective filter capacitors on the supplies.

b. Make sure shielding is in place.

c. Check for cold solder joints on grounds.

d. If the previous checks are good, turn the 3466A off.

e. Remove the TRMS Converter (U300) from its socket and turn the instrument on (see Schematic 3).

f. If the noise is gone, replace U300.

g. If the noise is still present, turn the 3466A off. Set the instrument to the ac volts function and 2V range.

h. With U300 still removed from its socket, connect a quiet +0.5V dc to pin 6 of the U300 socket.

i. Turn the 3466A on.

j. If noise is still noted, troubleshoot the A/D Converter. Try replacing U400 or the integrator capacitor (CR402).

k. If the noise is gone, do the following:

1. Turn the 3466A off. Remove the +0.5V dc from pin 6 of the U300 socket.

2. Place the 3466A into the test mode (see paragraph 8-103).

3. Connect pin 21 of U102 to ground (see Schematic 2).

4. Use the test oscilloscope to check for noise at JM101 (see Schematic 3). Since a small offset may be developed by the Input Amplifier, switching transients may be noted between the A/D runup and rundown operation. If noise is noted, try replacing U100.

5. If the reading on the scope is good, check for noise at JM201 (see Schematic 3). If noise is noted, try replacing U200.

**8-111. Some Ranges Inoperative in the DC Volts Function.** This failure is most likely caused by wrong gains

in the Input or Post Amplifiers, and by other circuitry. Check the following:

- a. **Only the 20mV and 200mV Ranges Fail.** Check for a defective U104, Q105, Q107, and associated circuitry.
- b. **The 1200V Range Reads Low.** Check for a defective C110.
- c. **Other Ranges Fail.** This failure is most likely caused by wrong gains in the Input or Post Amplifiers, or by other circuitry. Use the gains and amplifier output information listed in Table 8-7 to determine the defective circuitry. An example to determine the gain is as follows:

- 20mV - fail
- 200mV - fail
- 2V - fail
- 20V - good
- 200V - fail
- 1200V - good

This shows that the X10 gain in the Post Amplifier failed.

**Table 8-7. DC Gain**

	(B)			(D)
Range	Input Voltage	Input Amp (Gain)	Post Amp (Gain)	Post Amp Output
20mV	10mV	x10	x10	1V
200mV	100mV	x1	x10	1V
2V	1V	x.1	x10	1V
20V	10V	x.1	x1	1V
200V	100V	x.001	x10	1V
1200V	1000V	x.001	x1	1V

**8-112. DC Current Troubleshooting.** If both the dc volts and dc current functions fail, troubleshoot the dc volts function first (go to paragraph 8-108 through 8-111). If only the dc current function fails, the most likely causes are the current range switches, current shunts, or current protection circuitry (see Schematic 1). The dc volts function has to be operating since the voltage developed across the current shunts, when current is applied, is measured by the dc volts measuring circuitry. The voltage is used to develop the current reading.

**NOTE**

*Since AIR658 (Current Shunt Resistor) is at a critical value, use the following procedure if replacement is necessary.*

1. *With a marking pen, mark the resistor's leads at a distance exactly .64cm (.25 inches) from the component body.*
2. *Solder the resistor into the PC board with the mark on the resistor leads flush with the component side of the board.*

**8-113. Ohms Troubleshooting**

**8-114.** Before troubleshooting for ohms failures, make sure the dc volts function is operating correctly. Troubleshoot the dc volts function first before troubleshooting the ohms function (go to paragraphs 8-106). Ohms failures can consist of failures on some or all ranges. The ohms failures and troubleshooting information are in the following paragraphs.

**8-115. Constant Overload on All Ranges with Input Applied.** This failure can be caused by an open between the Input Amplifier and input terminals in the ohms circuitry. Check and make sure the function and range switches are good (see Schematic 1). The failure can also be caused by the Ohms Current Source or the Ohms Protection Circuitry (if too much current is output). If the switches are good, go to paragraph 8-120 (Ohms Circuitry Troubleshooting) for troubleshooting.

**8-116. Constant Zero Readings on All Ranges with Input Applied.** This failure can be caused if there is an open between the Ohms Current Source and the input terminals. Check and make sure the function and range switches are good (see Schematic 1). The failure can also be caused if the Ohms Current Source outputs no current. If the switches are good, go to paragraph 8-120 (Ohms Circuitry Troubleshooting) for troubleshooting.

**8-117. Noisy Readings on All Ranges.** Check for a noisy Ohms Current Source.

**8-118. Inaccurate Readings on All Ranges.** This failure can be caused by the Ohms Current Source or Ohms Protection Circuitry. Go to paragraph 8-120 (Ohms Circuitry Troubleshooting) for troubleshooting.

**8-119. Some Ranges Inoperative.** This failure can be caused by leaky diodes in the Ohms Protection Circuitry. Lift one end of protection diodes CR110, CR112, CR114, and CR116. If the ohms function is now good, replace all of the diodes. If the failure is still present, check the following:

- a. **Noise on the 20 Ohms Range Only.** Try replacing R428.
- b. **Only the 20 Ohms and 200 Ohms Ranges Fail.** Check and make sure U500 (pin 6) outputs 0.5V (see Schematic 2). If wrong, troubleshoot U500 and associated circuitry. If good, try replacing U102.
- c. **Offsets on the 20 Ohms and 200 Ohms Ranges.** Check Ohms Null Circuitry (Q400, Q401, and associated circuitry).
- d. **Other Ranges Fail.** This is most likely caused by the Input Hybrid (U102) or Ohms Current Source. Go to paragraph 8-120 (Ohms Circuitry Troubleshooting) step f for troubleshooting.

**8-120. Ohms Circuitry Troubleshooting.** If some ranges fail, go to step f for troubleshooting. If all ranges fail, a quick check of the ohms circuitry can be performed by measuring the voltage between the COM input terminal and circuit ground (connect positive input of the test Digital Multimeter to COM and negative to ground). With a 1k ohm resistor connected to the input terminals, the voltage should be  $-1.0V$ . Varying the resistance should result in a proportionally varying voltage (e.g., 1.9k ohms gives  $-1.9V$ , 500 ohms gives  $-0.5V$ , etc.). If a failure is noted, do the following:

a. Lift one end of protection diodes CR110, CR112, and CR116. If the ohms function is now good, replace the defective diode.

b. Set the 3466A into the ohms function and the 2k ohms range.

c. Connect a 1k ohm resistor across the input terminals.

d. Connect a short clip lead between the cathode of CR118 (see Schematic 1) and the COM input terminals.

e. If the voltage between COM and ground is  $-1.0V$ , the Ohms Protection Circuitry is causing the failure. Use the voltages in the Simplified Schematic (Figure 8-17) to isolate the defective component.

f. If the voltage is other than  $-1.0V$ , remove the 1k ohm resistor from the input terminals. Check the Ohms Current Source as follows:

1. Make sure one end of CR116 is lifted.
2. Lift the anode of CR118 (see Schematic 1) to disconnect the Ohms Protection Circuitry.
3. Set the 3466A to the 2k ohms range.
4. Connect one input the test Digital Multimeter to the cathode of CR118 and the other to the V input terminal.
5. If all the ohms ranges fail and the current from the Ohms Current Source is good (i.e., 1mA), as measured on the test multimeter, the current source is most likely good. Troubleshoot for a defective Input Amplifier.
6. If only some ranges fail, compare the reading on the test multimeter, for each inoperative range, with the readings listed in Table 8-8. (Since the recommended test multimeter may not be able to read the lower currents, another milliammeter may be required to make the checks.)
7. If the 1mA current or any other current is wrong, troubleshoot U500, U102, and associated circuitry.

**Table 8-8. Ohms Current Source**

Range $\Omega$	$V_{Ref}$	$R_{Ref}$ ( $\Omega$ )	$I_x$ (mA)
20M	1V	10M	.001
2M	1V	1M	.001
200K	1V	100K	.01
20K	1V	10K	.1
2K	1V	1K	1
200	.5V	100	5
20	.5V	100	5

### 8-121. AC Troubleshooting

8-122. Before troubleshooting for ac failures, make sure the dc volts function is operating correctly. Troubleshoot the dc volts function first before troubleshooting the ac volts function (go to paragraphs 8-106). AC failures can consist of ac volts and/or ac current function failures on some or all ranges. The following are the failures and troubleshooting information.

#### NOTE

*Jumpers JM101 and JM201 may be marked J101 and J201, respectively, on the printed circuit board.*

**8-123. Overload, Floating, Constant Zero, or Inaccurate Readings on All Ranges in the AC Volts Function.** This failure can be caused by the Input or Post Amplifiers, TRMS Converter, or associated circuitry. Unlike the dc volts function, the outputs of the Input and Post Amplifiers are not switched between the A/D runup and rundown operations, simplifying troubleshooting.

8-124. To troubleshoot for overload, floating, or constant zero readings on all ranges, use the procedure that follows this paragraph. The procedure can also be used to troubleshoot for inaccurate readings, if they occur at both high and low frequencies. If the inaccuracy is only noted at high frequency, go to paragraph 8-125 (Frequency Response Failure) for troubleshooting.

a. Set the 3466A to the ac volts function and the 2V range.

b. Apply a 1V, 200Hz sine wave to the 3466A's input terminals.

c. Use the test oscilloscope to measure for a 0.5V (1.41V peak to peak), 200Hz sine wave at jumper JM201 (see Schematic 3). Make sure there is no oscillation present on the sine wave. (Oscillation can be caused by U200 and/or C202.) If the 3466A is inaccurate, use the test Digital Multimeter to check and make sure the signal is at approximately 0.5V.

d. If the signal is good, the TRMS Converter (U300) or associated circuitry may be defective. To check this, make sure the converter's output (U300 pin 6) is  $+ .5V$

dc. If good, R303, R305, R307, or RT300 may be defective. If wrong, check the TRMS Converter and its external circuitry.

e. If the signal is wrong or missing, use the test oscilloscope to measure for a 0.5V (1.41V peak to peak), 200Hz sine wave at jumper JM101. Make sure there is no oscillation present on the sine wave. If the 3466A is inaccurate, use the test Digital Multimeter to check and make sure the signal is at approximately 0.5V.

f. If the signal is good, the Post Amplifier, U402, and associated circuitry may be defective. Before troubleshooting the amplifier, make sure U300 is not causing the failure. Lift jumper JM200 and check the signal again. If now good, replace U300. If still wrong, troubleshoot the Post Amplifier circuitry.

g. If the signal at JM101 is wrong, check for a 1V, 200Hz signal at U102 pin 23 (see Schematic 2).

h. If the signal at U102 pin 23 is good, the Input Amplifier, U102, and associated circuitry may be defective. Before troubleshooting the circuitry, lift jumper JM101 (see Schematic 3). If the output of the Input Amplifier is now good (i.e., 0.5V, 200Hz sine wave), U402 may be loading down the amplifier. If the signal at JM101 is still wrong, troubleshoot the Input Amplifier circuitry.

i. If the voltage at U102 pin 23 is wrong or missing, use the test oscilloscope to trace the 1V, 200Hz signal from the input terminals to U102 pin 23 (see Schematics 1 and 2). Check for open circuitry.

**8-125. Frequency Response Failure.** Do the following:

a. Check R100, R108, C106, and C108 in the input attenuator circuitry (see Schematic 2).

b. Check for a defective C200, C202, or U200.

c. Check for a defective RMS Converter (U300).

**8-126. All Ranges in the AC Volts Function are Noisy.** Check for oscillation in the Input and Post Amplifiers circuitry (go to paragraph 8-123).

**8-127. Excessive Offsets in the AC Volts Function.** Check for leaky protection diodes CR101 and CR103 (see Schematic 2). Try replacing the TRMS Converter U300 (see Schematic 3).

**8-128. Some Ranges Inoperative in the AC Volts Function.** This failure is most likely caused by wrong gains in the Input or Post Amplifiers, or by other circuitry. Use the gains and amplifier output information listed in Table 8-9 to determine the defective circuitry.

**Table 8-9. AC Gain**

	(A)		(D)		
Range	Input Voltage	Input Amp (Gain)	Post Amp (Gain)	Post Amp Output	
200mV	.1V	x.5	x10	.5V	
2V	1V	x.5	x1	.5V	
20V	10V	x.005	x10	.5V	
200V	100V	x.005	x1	.5V	
1200V	1kV	x.0005	x1	.5V	

**8-129. AC Current Troubleshooting.** If both the ac volts and ac current functions fail, troubleshoot the ac volts function first (go to paragraph 8-123 through 8-128). If only the ac current function fails, check and make sure the dc current function is good. If the dc current function fails, troubleshoot it instead. If the dc current function is good, the most likely causes are the current range switches (see Schematic 1).

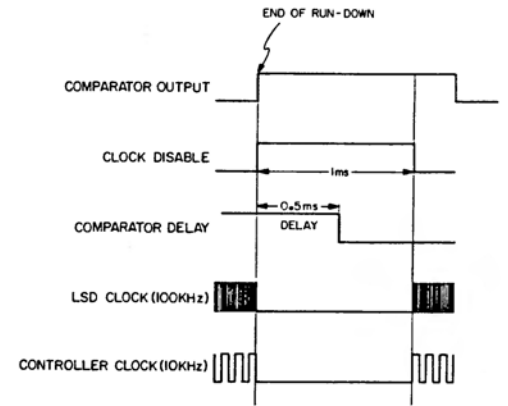
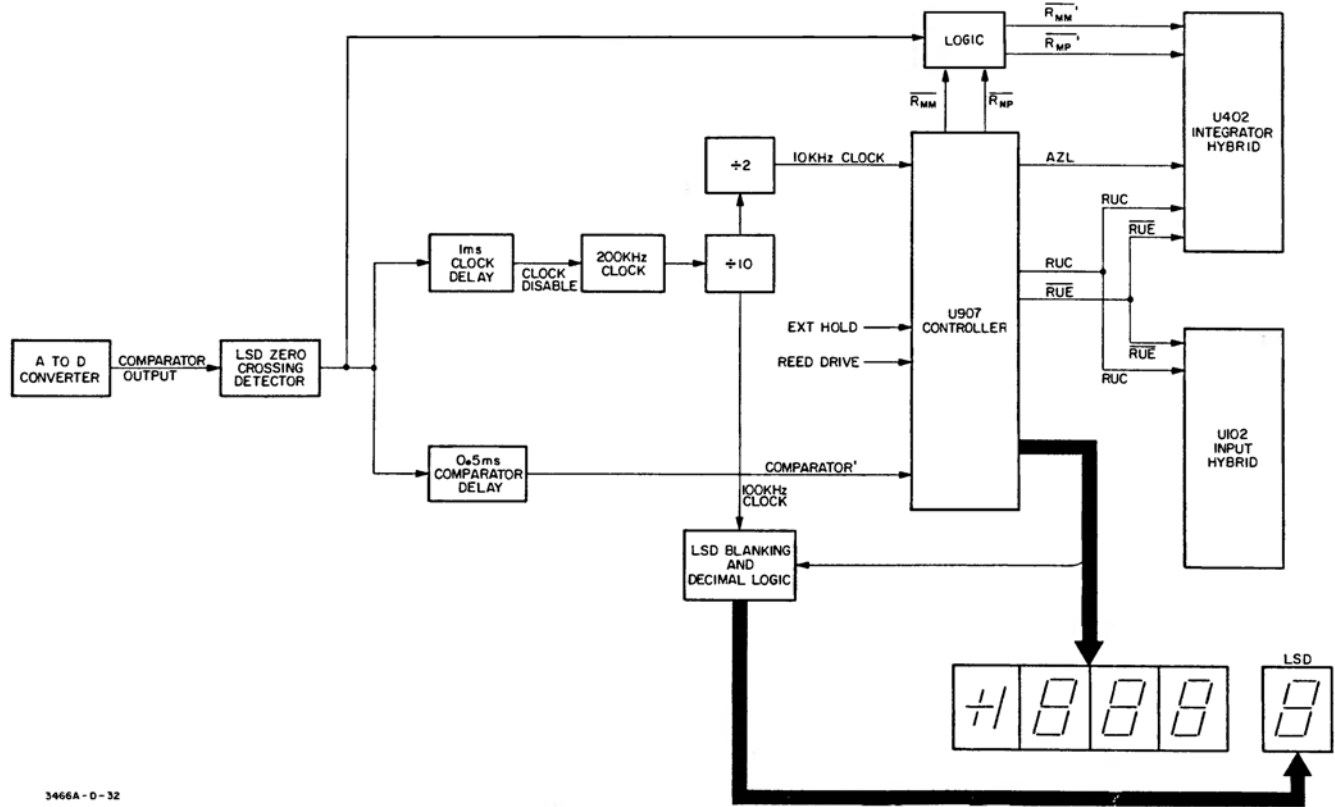

3466A - 0 - 32

Figure 8-16. Logic Interface Block Diagram  
8-25

RANGE/INPUT	INPUT AMP	POST AMP	OVERALL GAIN/ OUTPUT VOLTAGE
20mV/10mV			X100 /
200mV/100mV			X10 /
2V/1V			X1 /
20V/10V			X0.1 /
200V/100V			X0.01 /
200V/100V			X0.001 /

3466A - B - 27

DC Gain Configuration.



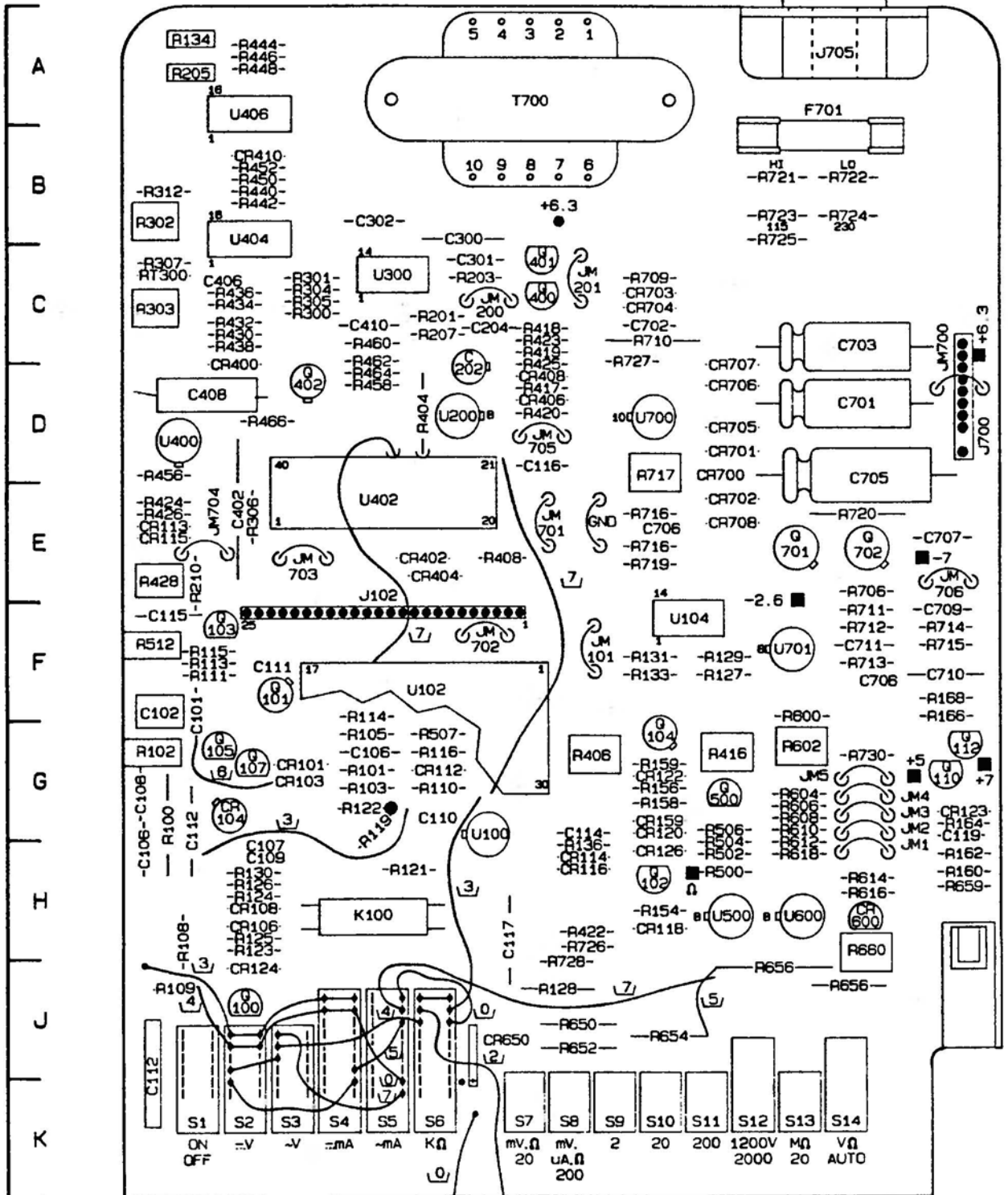

NOTE: ALL FLYING LEADS ARE WHITE (9) UNLESS OTHERWISE MARKED

A1

03466-66501

# COMPONENT LOCATOR FOR SCHEMATIC 1

Component	Location	Component	Location
C100	J,K1	R154	H5
C119	G8	R156	G5
CR118	H5	R158	G5
CR120	G5	R159	G5
CR122	G5	R160	H8
CR123	G8	R162	H8
CR126	H5	R164	G8
CR159	G5	R166	F8
CR650	J4	R168	F8
Q102	H5	R650	J5
Q104	G5	R652	J5
Q110	G8	R654	J5,6
Q112	G8	R656	I6
		R658	I7
		R659	H8
		R660	H7
		R730	G7

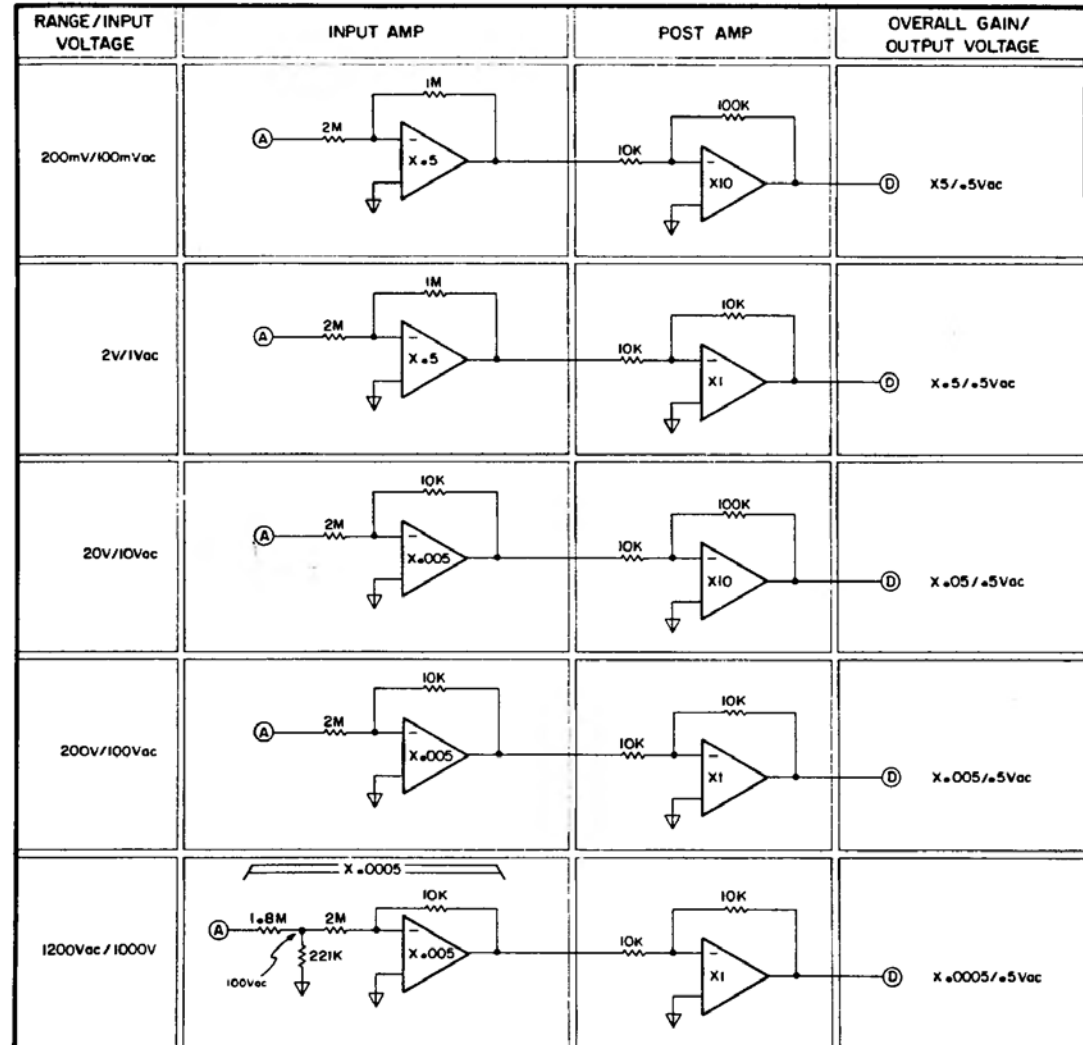

3466A - C - 28

AC Gain Configurations.

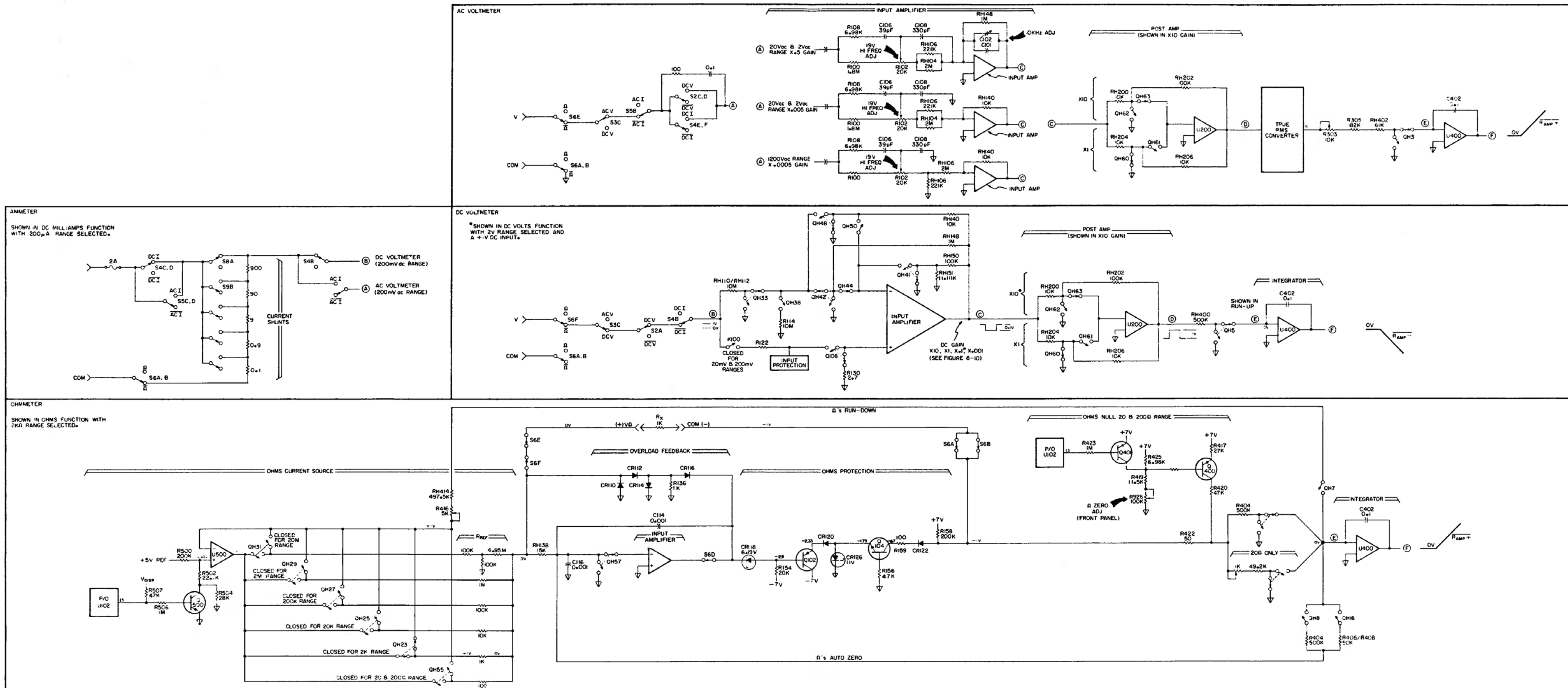

Figure 8-17. Simplified Analog Schematic

NOTE 1

THE SCHEMATIC IS SHOWN WITH DCV (FUNCTION) AND 2V (RANGE) SELECTED. PROMINANT SCHEMATIC LINES SHOW THE SIGNAL PATH FOR THIS SWITCH SETTING.

NOTE 2

SWITCHES S2 THROUGH S14 ARE SCHEMATICALLY ORIENTED IN ASCENDING NUMERICAL ORDER FROM LEFT TO RIGHT. THIS ORIENTATION IS THE SAME AS THE PHYSICAL ORIENTATION OF THE ACTUAL SWITCHES AS THEY ARE VIEWED ON THE COMPONENT LOCATOR ON THIS PAGE. SWITCH SECTIONS ARE LABELED A THROUGH F ON THE SCHEMATIC AS SHOWN IN THE DIAGRAM BELOW:

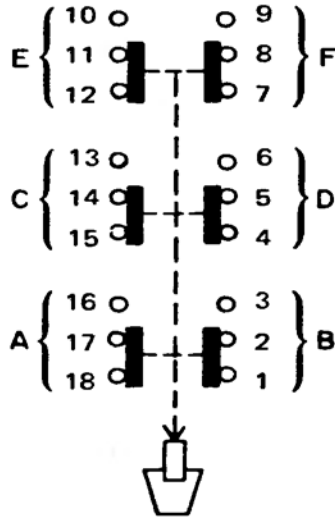

SWITCH TERMINALS ARE NUMBERED IN A COUNTER-CLOCKWISE DIRECTION WHEN VIEWING THE SWITCH BANK FROM THE COMPONENT SIDE (SEE ABOVE).

NOTE 3

U102 AND U402 ARE HYBRID INTEGRATED CIRCUITS. FINE LINE RESISTORS AND MOS FET SWITCHES WHICH ARE PART OF THE HYBRIDS ARE SHOWN ON THE SCHEMATIC FOR OPERATIONAL CLARIFICATION ONLY. THESE COMPONENTS ARE NOT INDIVIDUALLY SERVICEABLE.

NOTE 4

SIMPLIFIED SCHEMATIC REPRESENTATIONS OF MOS FET SWITCHES ARE USED FOR SCHEMATIC CLARITY. COMPARISONS OF THE SIMPLIFIED, ACTUAL AND FUNCTIONAL SCHEMATIC REPRESENTATIONS ARE AS FOLLOWS:

	SIMPLIFIED	ACTUAL	FUNCTIONAL
SINGLE MOS FET SWITCH			
DUAL MOS FET SWITCH			

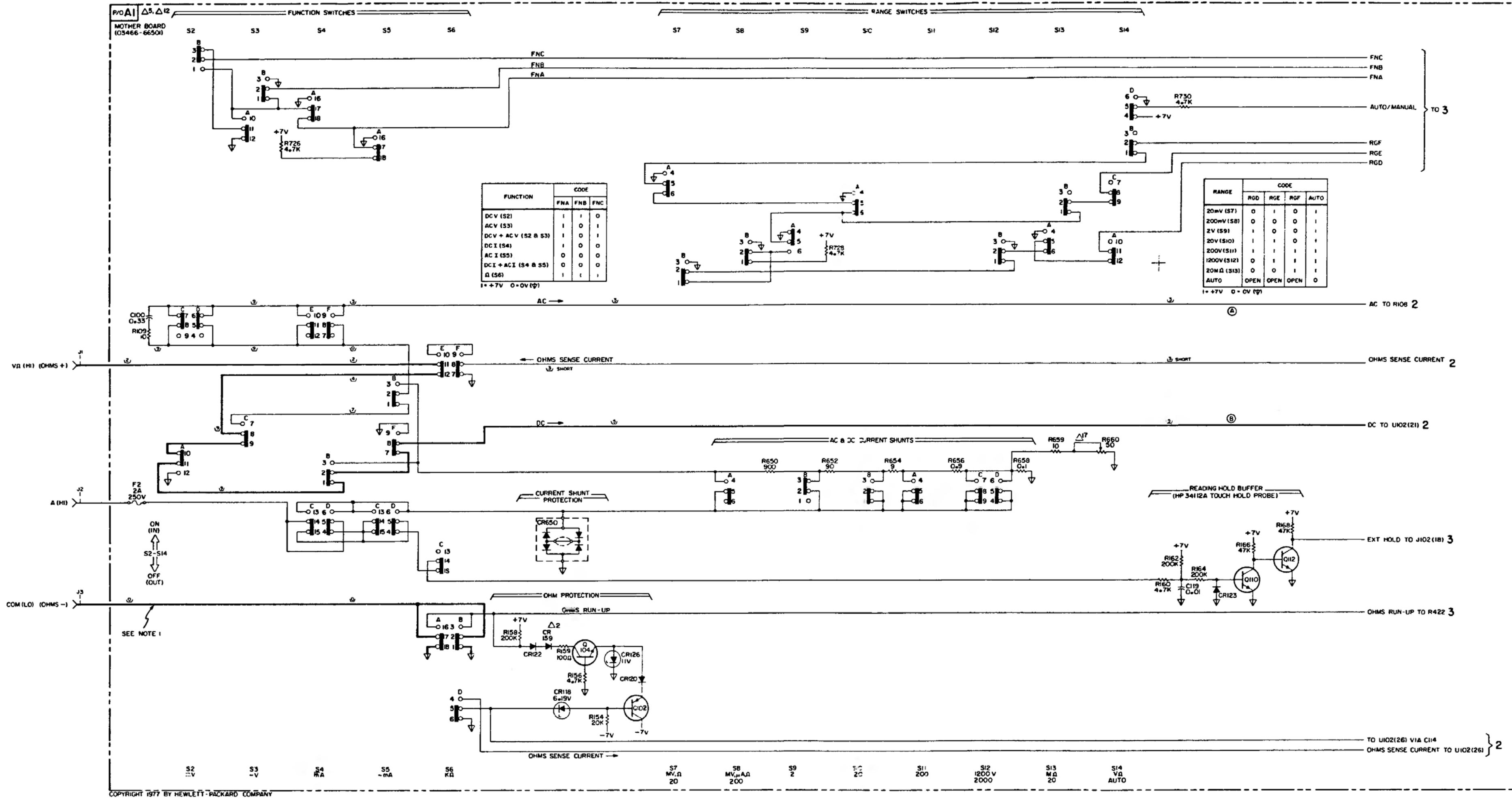

Figure 8-18. Input Switching Schematic  
8-29

NOTE 1

THE SCHEMATIC IS SHOWN WITH DCV (FUNCTION) AND 2V (RANGE) SELECTED PROMINANT SCHEMATIC LINES SHOW THE SIGNAL PATH FOR THIS SWITCH SETTING.

NOTE 2

U102 AND U402 ARE HYBRID INTEGRATED CIRCUITS. FINE LINE RESISTORS ARE MOS FET SWITCHES WHICH ARE PART OF THE HYBRIDS ARE SHOWN ON THE SCHEMATIC FOR OPERATIONAL CLARIFICATION ONLY. THESE COMPONENTS ARE NOT INDIVIDUALLY SERVICEABLE.

NOTE 3

SIMPLIFIED SCHEMATIC REPRESENTATIONS OF MOS FET SWITCHES ARE USED FOR SCHEMATIC CLARITY. COMPARISONS OF THE SIMPLIFIED, ACTUAL AND FUNCTIONAL SCHEMATIC REPRESENTATIONS ARE AS FOLLOWS:

	SIMPLIFIED	ACTUAL	FUNCTIONAL
SINGLE MOS FET SWITCH			
DUAL MOS FET SWITCH			

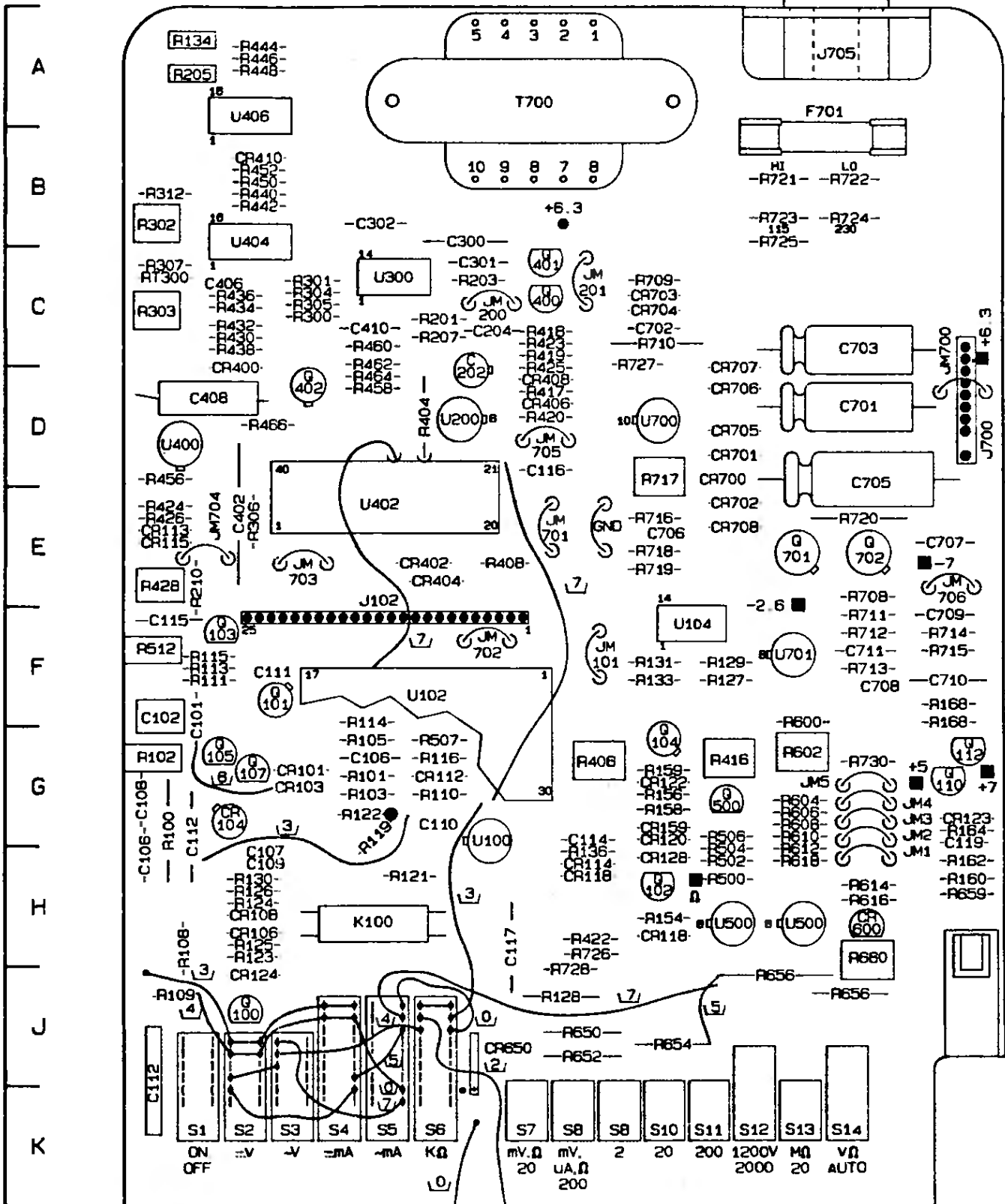

NOTE: ALL FLYING LEADS ARE WHITE (9) UNLESS OTHERWISE MARKED

A1

03466-66501

## COMPONENT LOCATOR FOR SCHEMATIC 2

Component	Location	Component	Location	Component	Location
C101	F1,2	CR124	H2	R122	G3
C102	F1			R123	H2
C105	F3	K100	H3	R124	H2
C106	G1			R125	H2
C107	G,H2	Q100	I2	R126	H2
C108	G1	Q101	F2	R127	F6
C109	H2	Q103	F2	R128	I5
C110	G3	Q105	F,G2	R129	F6
C111	F2	Q107	G2	R130	H2
C114	G5	Q500	G6	R131	F5
C115	E,F1			R132	A1,2
C116	D4	R100	G1	R133	F5
C117	H4	R101	G3	R134	A1,2
		R102	G1	R136	G,H5
CR101	G2	R103	G3	R152	F1
CR103	G2	R105	F3	R416	G6
CR104	G2	R108	H1	R500	H6
CR106	H2	R109	I1	R502	H6
CR108	H2	R111	F1,2	R504	G6
CR110	G3	R113	F1,2	R506	G6
CR112	G3	R114	F3	R507	F3
CR113	E1	R115	F1,2		
CR114	H5	R116	F3	U100	G4
CR115	E1	R119	G3	U102	F,G,3,4
CR116	H5	R120	E1	U104	F5,6
		R121	G3		



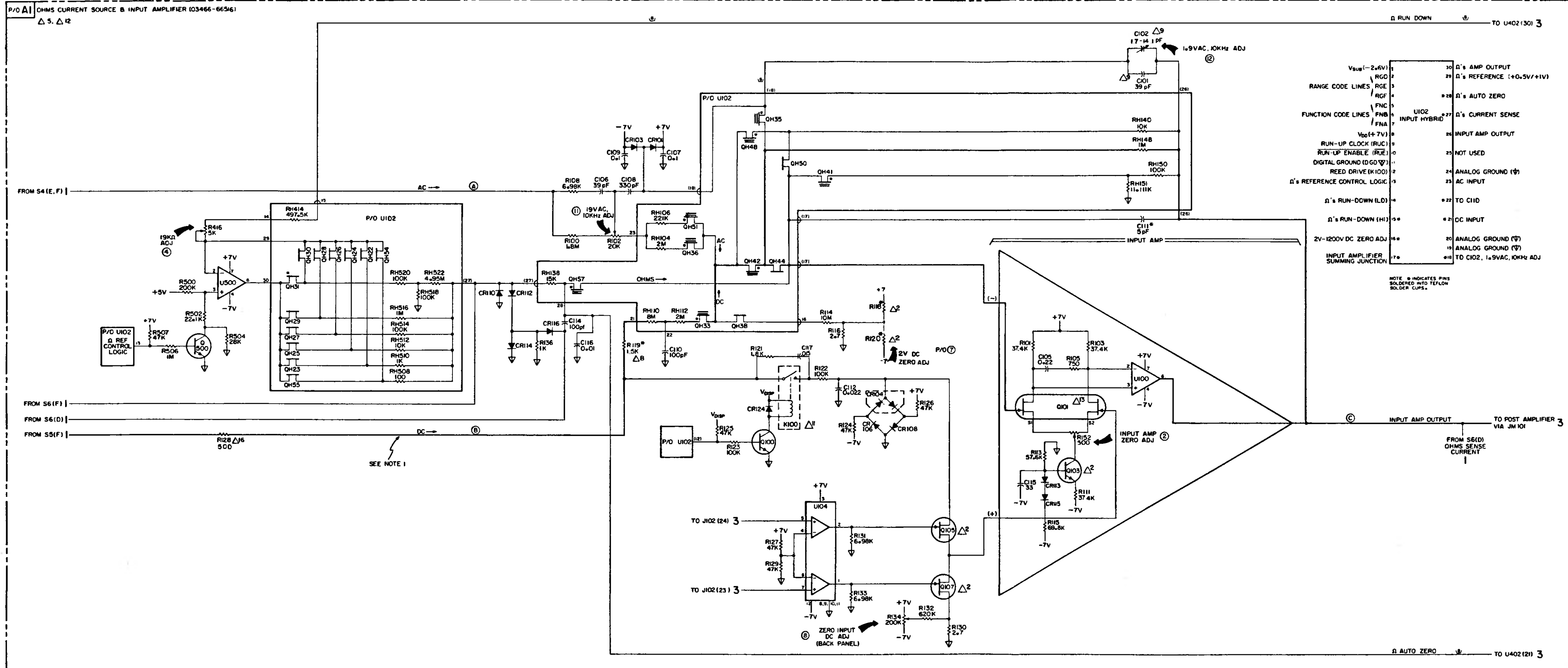

COPYRIGHT 1977 BY HEWLETT-PACKARD COMPANY

344A-E-3

Figure 8-19. Ohms Current Source and Input Amplifier Schematic

NOTE 1

THE SCHEMATIC IS SHOWN WITH DCV (FUNCTION) AND 2V (RANGE) SELECTED. PROMINANT SCHEMATIC LINES SHOW THE SIGNAL PATH FOR THIS SWITCH SETTING.

NOTE 2

U102 AND U402 ARE HYBRID INTEGRATED CIRCUITS. FINE LINE RESISTORS AND MOST FET SWITCHES WHICH ARE PART OF THE HYBRIDS ARE SHOWN ON THE SCHEMATIC FOR OPERATIONAL CLARIFICATION ONLY. THESE COMPONENTS ARE NOT INDIVIDUALLY SERVICEABLE.

NOTE 3

SIMPLIFIED SCHEMATIC REPRESENTATIONS OF MOS FET SWITCHES ARE USED FOR SCHEMATIC CLARITY. COMPARISONS OF THE SIMPLIFIED, ACTUAL AND FUNCTIONAL SCHEMATIC REPRESENTATIONS ARE AS FOLLOWS:

V <sub>SUB</sub> (-2.6 V)	1	*40	INTEGRATOR SUMMING JCT
AUTO ZERO LOGIC (AZL)	2	39	NC
RANGE CODE LINES {	RGD 3	*38	AUTO ZERO (C408)
	RGE 4	37	NC
	NC 5	36	NC
	RGF 6	35	AUTO ZERO
FUNCTION CODE LINES {	FNC 7	34	AC AUTO ZERO
	FNB 8	33	5 V REFERENCE
	FNA 9	32	AC RUN UP
V <sub>DD</sub> (+7 V)	10	31	NC
DIGITAL GROUND (DGD)	11	*30	Ω's RUN DOWN
RUN-UP CLOCK (RUC)	12	29	NC
RUN-UP ENABLE (RUE)	13	*28	Ω's RUN UP
R <sub>AMP</sub> (-) (R <sub>MM</sub> )	14	27	NC
R <sub>AMP</sub> (+) (R <sub>MP</sub> )	15	26	POST AMP OUTPUT (DC RUN UP)
NC	16	25	POST AMP INPUT
Ω's RUN UP (20 Ω)	17*	24	C204 (POST AMP)
NC	18	23	NC
POST AMP SUMMING JCT	19	22	NC
ANALOG GROUND	20	*21	Ω's AUTO ZERO

1      2      3      4      5      6      7      8

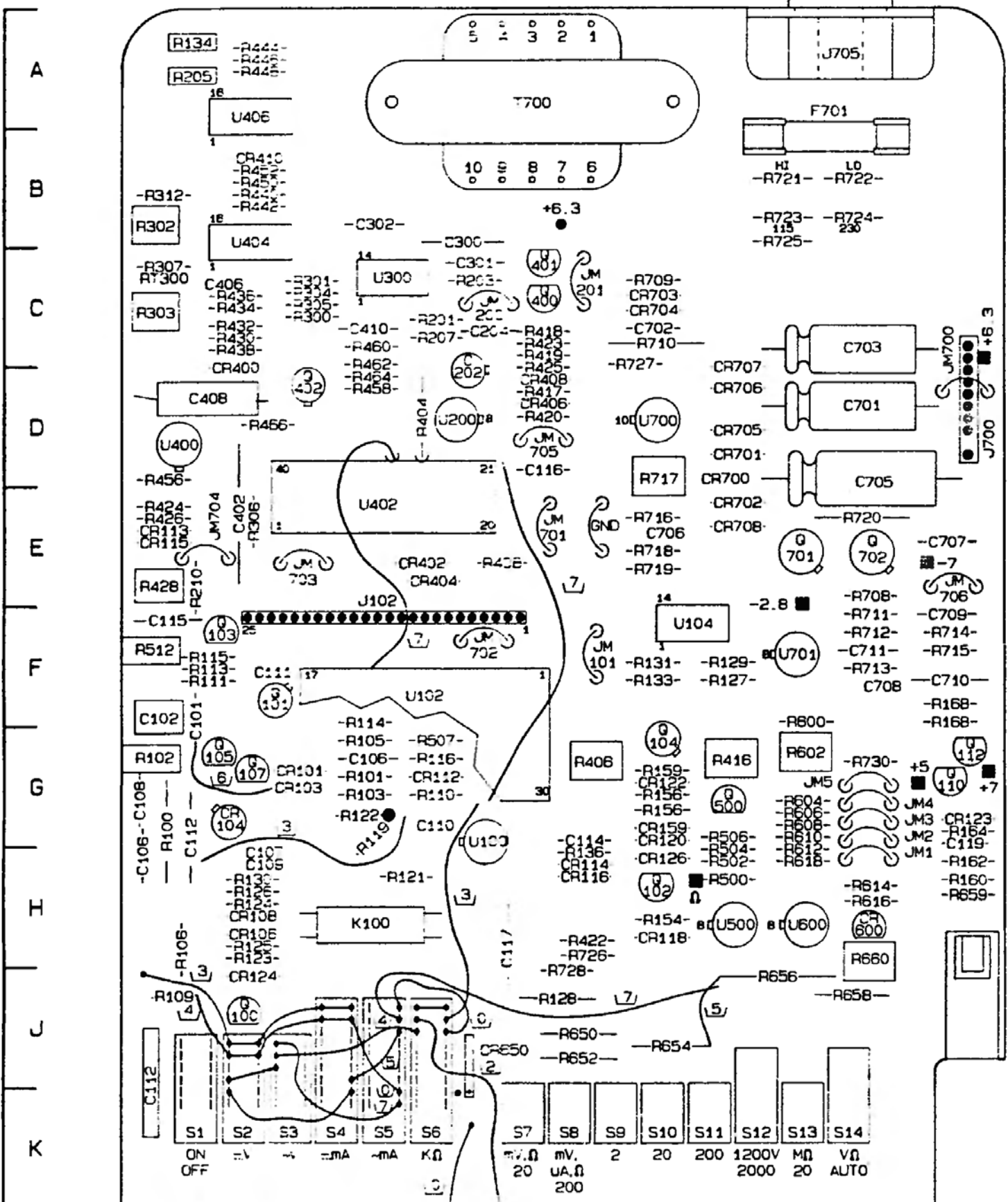

NOTE: ALL FLYING LEADS ARE WHITE UNLESS OTHERWISE MARKED

### COMPONENT LOCATOR FOR SCHEMATIC 3

Component	Location	Component	Location	Component	Location
C200	C4	JM705	D4	R438	C2
C202	C,D4			R440	B2
C204	C4	Q400	C4	R442	B2
C210	C,D3	Q401	C4	R444	A2
C300	B4	Q402	D2	R445	A2
C301	C4			R448	A2
C302	B3	R201	C3	R450	B2
C402	E2	R203	C4	R452	B2
C406	C2	R205	A2	R456	D1
C408	D1,2	R207	C3	R458	D3
C410	C3	R300	C2	R462	C3
		R301	C2,3	R464	D3
CR400	C2	R303	C1	R466	D2
CR402	E3	R304	C2,3	R600	F6,7
CR404	E3	R305	C2	R602	G6,7
CR406	D4	R306	E2	R604	G6,7
CR408	D4	R307	C1	R606	G6,7
CR410	B2	R404	D3	R608	G6,7
CR600	H7	R406	G5	R610	G6,7
		R408	E4	R612	G6,7
J102	E2,4	R417	D4	R614	H7
		R418	C4	R616	H7
JM1	H7	R419	C4	R618	H6,7
JM2	G7	R420	D4		
JM3	G7	R423	C4	RT300	C1
JM4	G7	R424	E1		
JM5	G7	R425	C4	U200	D4
JM101	F5	R426	E1	U300	C3
JM200	C4	R428	E1	U400	D1
JM201	C5	R430	C2	U402	D,E2,4
JM701	E4	R432	C2	U404	B2
JM703	E2	R434	C2	U406	A2
JM704	E2	R436	C2	U600	H7

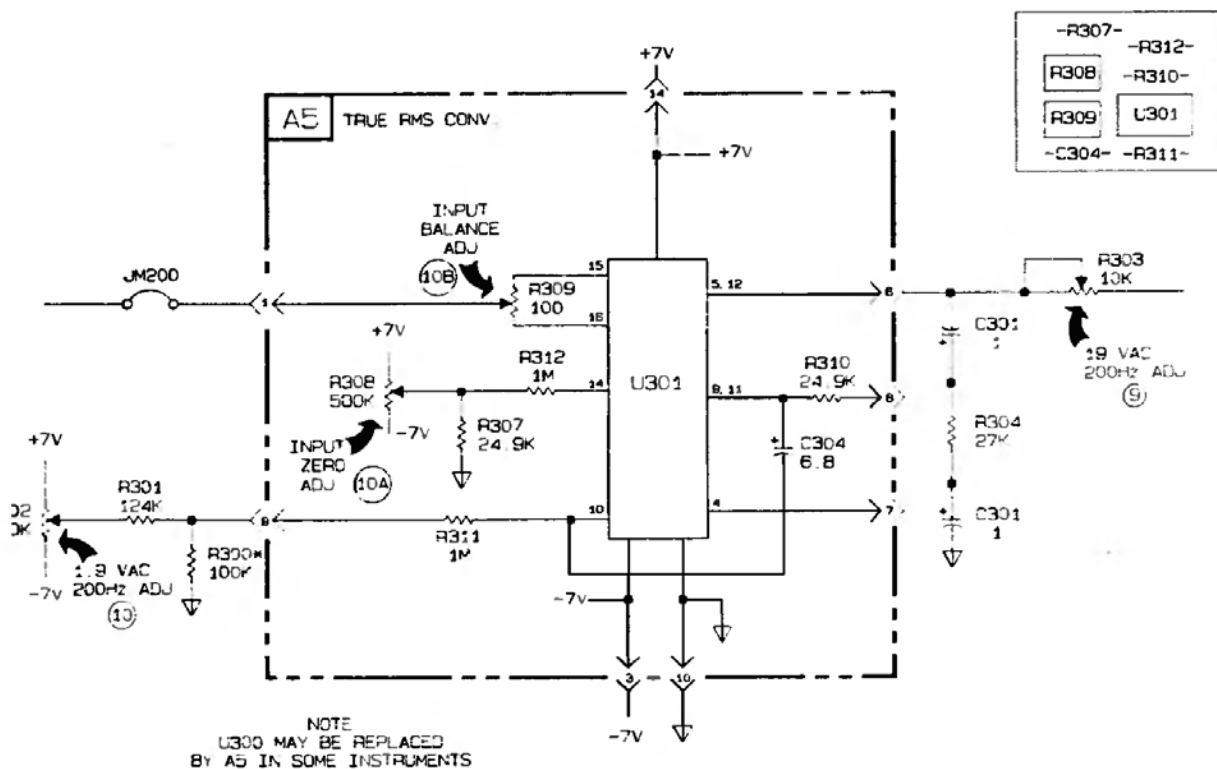

FUNCTION	CODE		
	FNA	FNB	FNC
DCV (52)	1	1	0
ACV (53)	1	0	1
DCV + ACV (52 & 53)	1	0	1
DC I (54)	0	0	0
AC I (55)	0	0	0
DC I + AC I (54 & 55)	0	0	0
Ω (56)	1	1	1

RANGE	CODE			
	RGD	RGE	RHF	AUTO
200mV (57)	0	0	0	0
200mV (58)	0	0	0	1
2V (59)	1	0	0	0
20V (60)	1	0	0	1
200V (61)	1	1	0	0
200V (62)	1	1	0	1
200mΩ (63)	0	0	1	0
200mΩ (64)	0	0	1	1
AUTO	OPEN	OPEN	OPEN	0

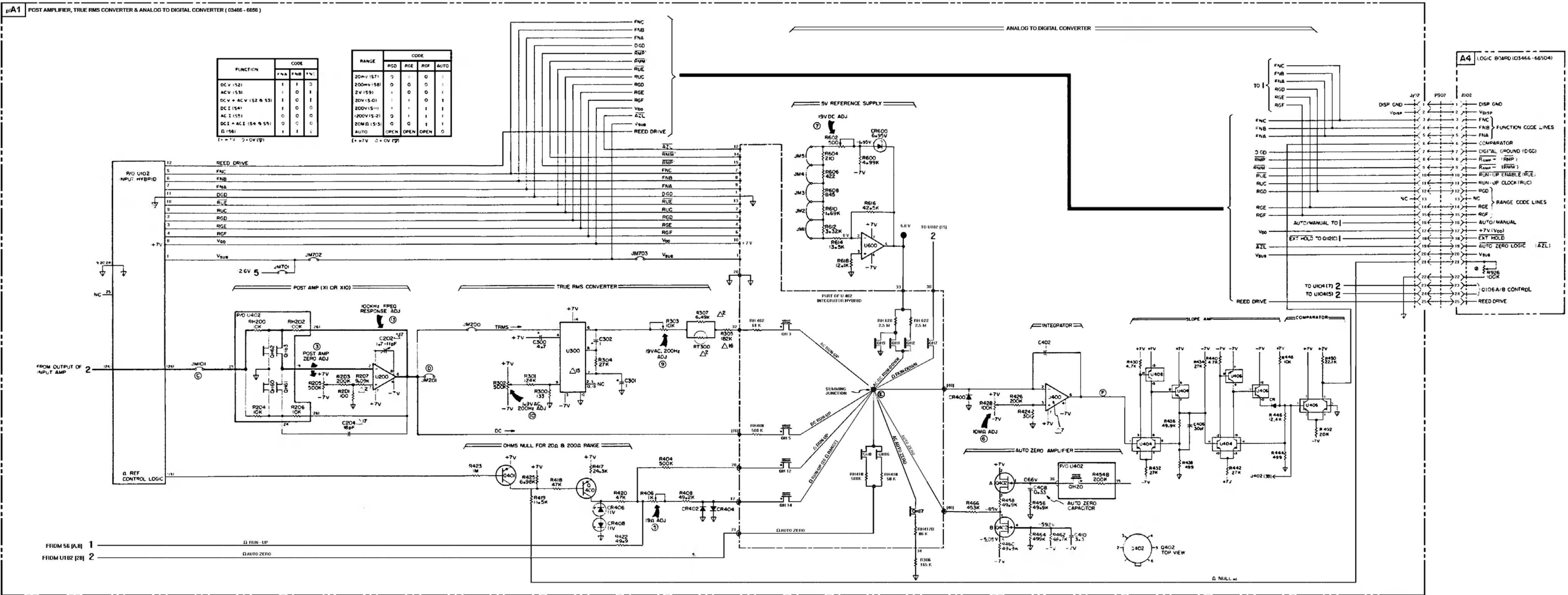
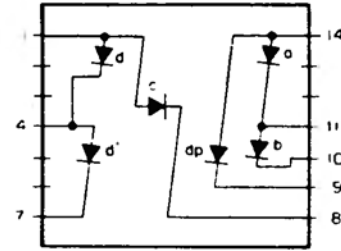
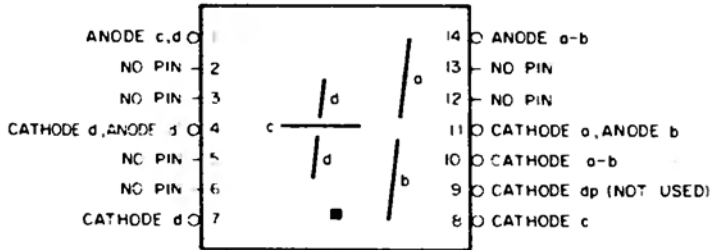
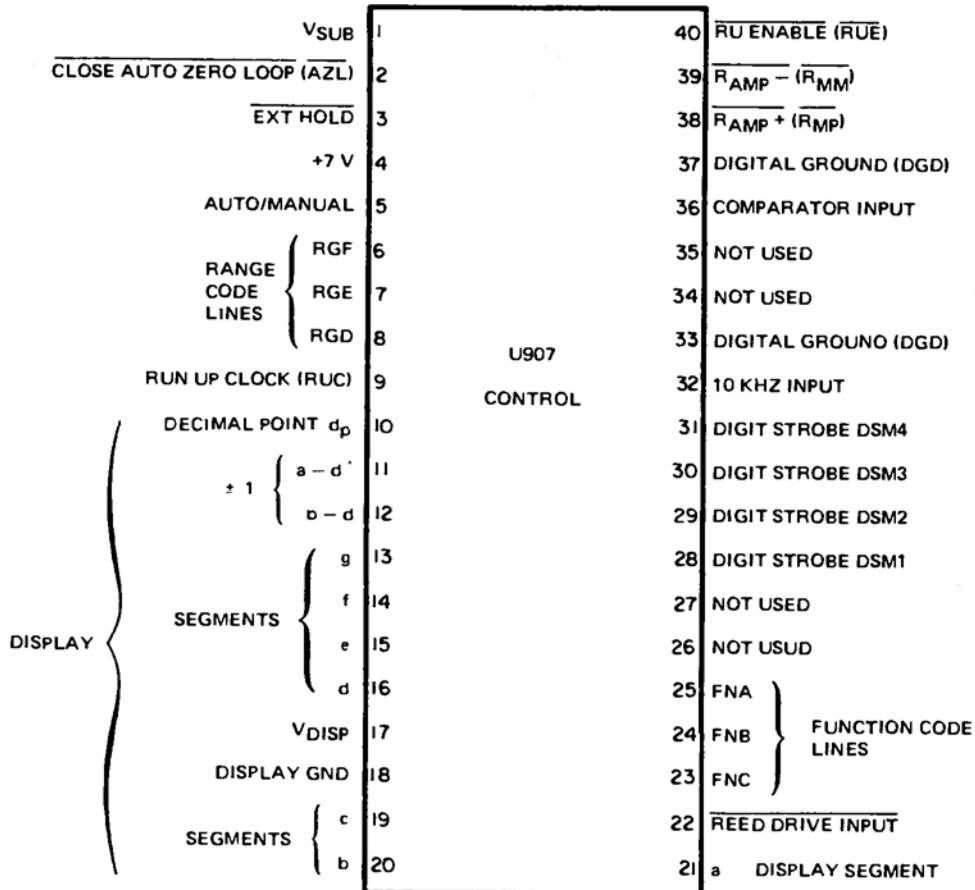
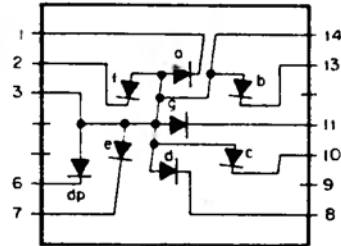
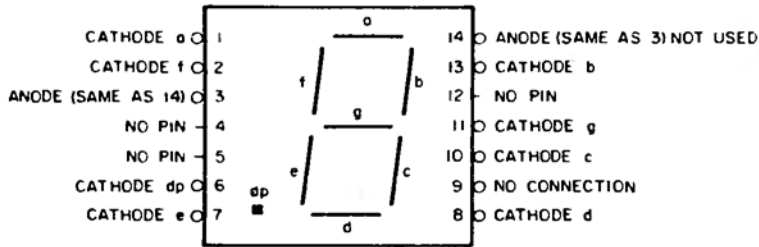

Figure 8-20. Post Amplifier, TRMS Converter, and Analog to Digital Converter Schematic 8-33

DSMI (1990-0532)



DSM2, DSM3, DSM4, DSM5 (1990-0531)



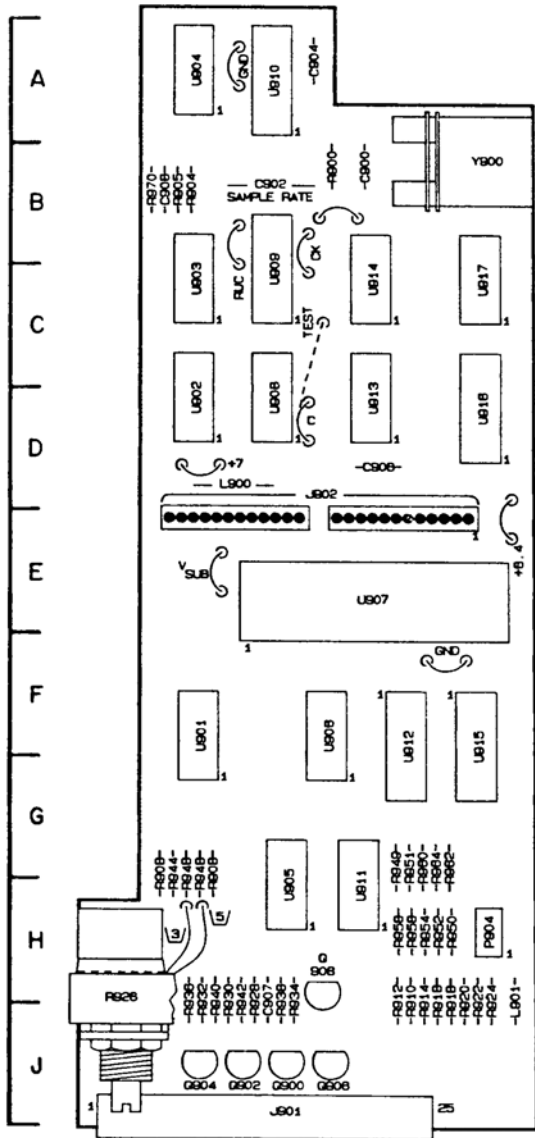

A4

03466-66514

### COMPONENT LOCATOR FOR SCHEMATIC 4

Component	Location	Component	Location	Component	Location
C900	B	R910	H	R958	H
C902	B	R912	H	R960	G
C904	A	R914	H	R962	G
C906	D	R916	H	R964	G
C907	H	R918	H	R970	B
C908	B	R920	H	U901	F
J901	J	R922	H	U902	C,D
J902	D,E	R924	H	U903	C
L900	D	R926	H	U904	A
L901	H	R928	H	U905	G
P904	H	R930	H	U906	F
Q900	J	R932	H	U907	E
Q902	J	R934	H	U908	C,D
Q904	J	R936	H	U909	C
Q906	J	R938	H	U910	A
Q908	H	R940	H	U911	G
R900	B	R942	H	U912	F
R904	B	R944	G	U913	C,D
R905	B	R946	G	U914	C
R906	G	R948	G	U915	F
R908	G	R949	G	U916	C,D
		R950	H	U917	C
		R951	G	Y900	B
		R952	H		
		R954	H		
		R956	H		

LEVELS AND WAVEFORMS FOR +8000  
COUNT TEST, 2 VDC RANGE, +1 VDC  
INPUT.

HI = +7 V

LO = 0 V

⏏ = SWITCHING SIGNAL, 0 TO +7 V

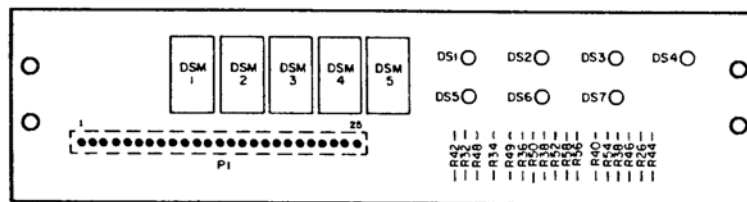

3466A-B-6

A2

03466-66502

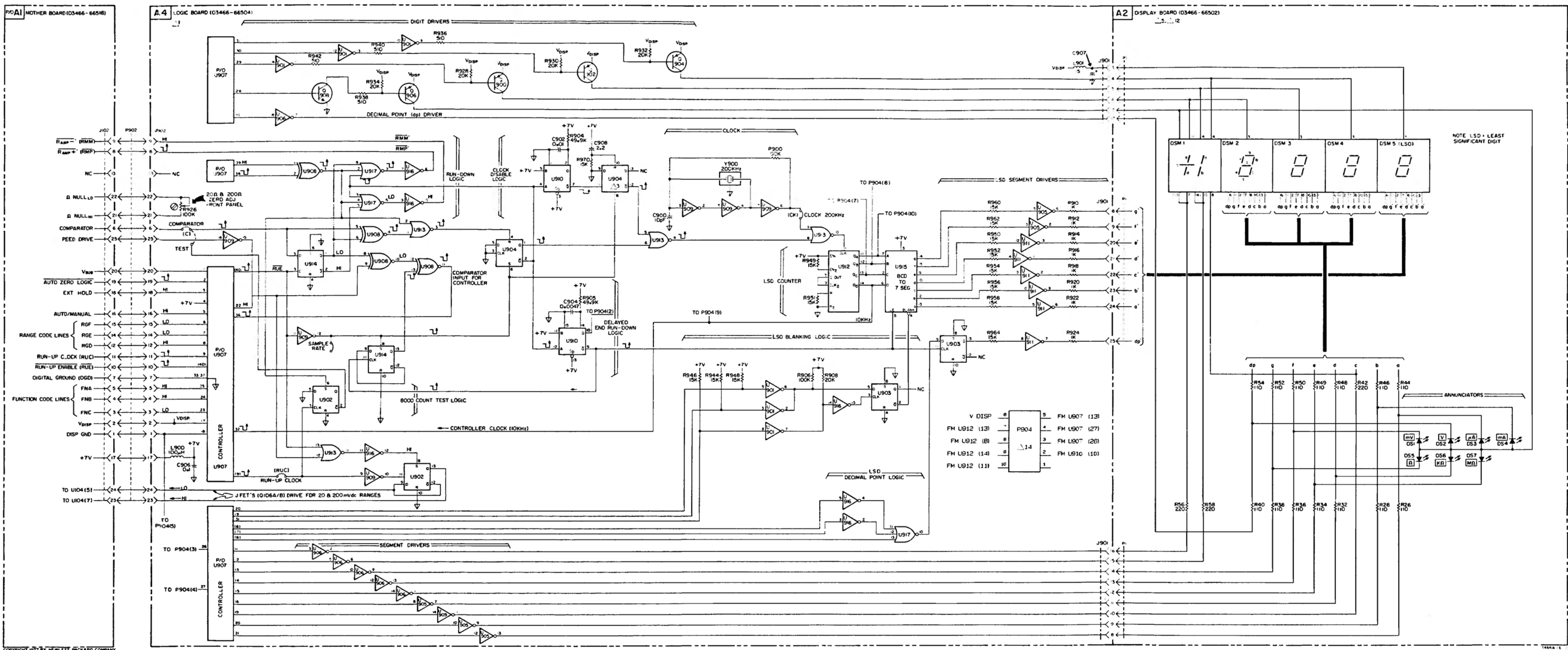
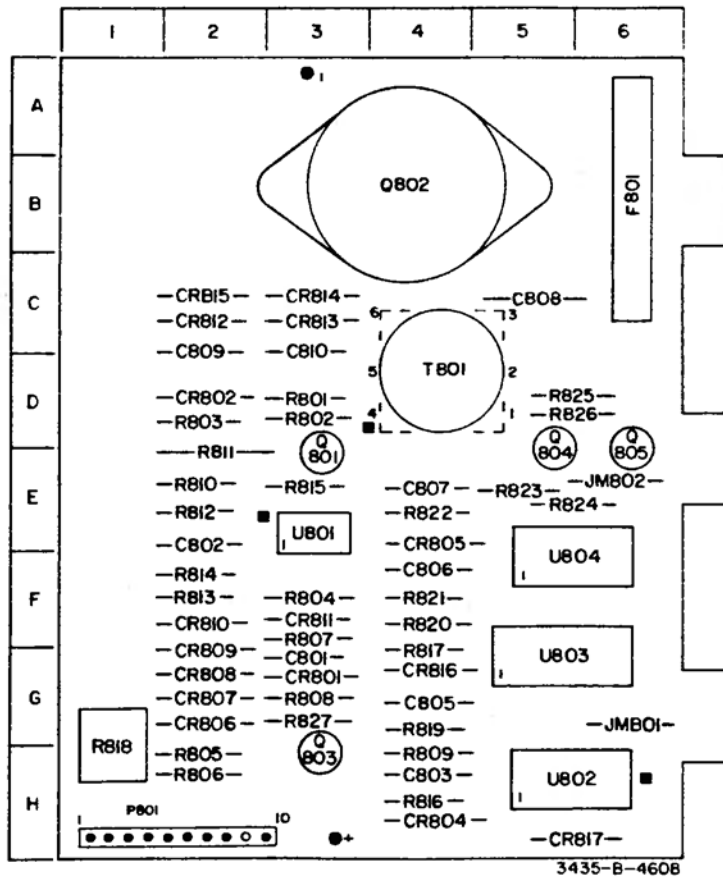

Figure 8-21. Logic and Display Schematic  
8-35





3435-B-4608

A3

-hp- Part No. 03435-66503

1 2 3 4 5 6 7 8

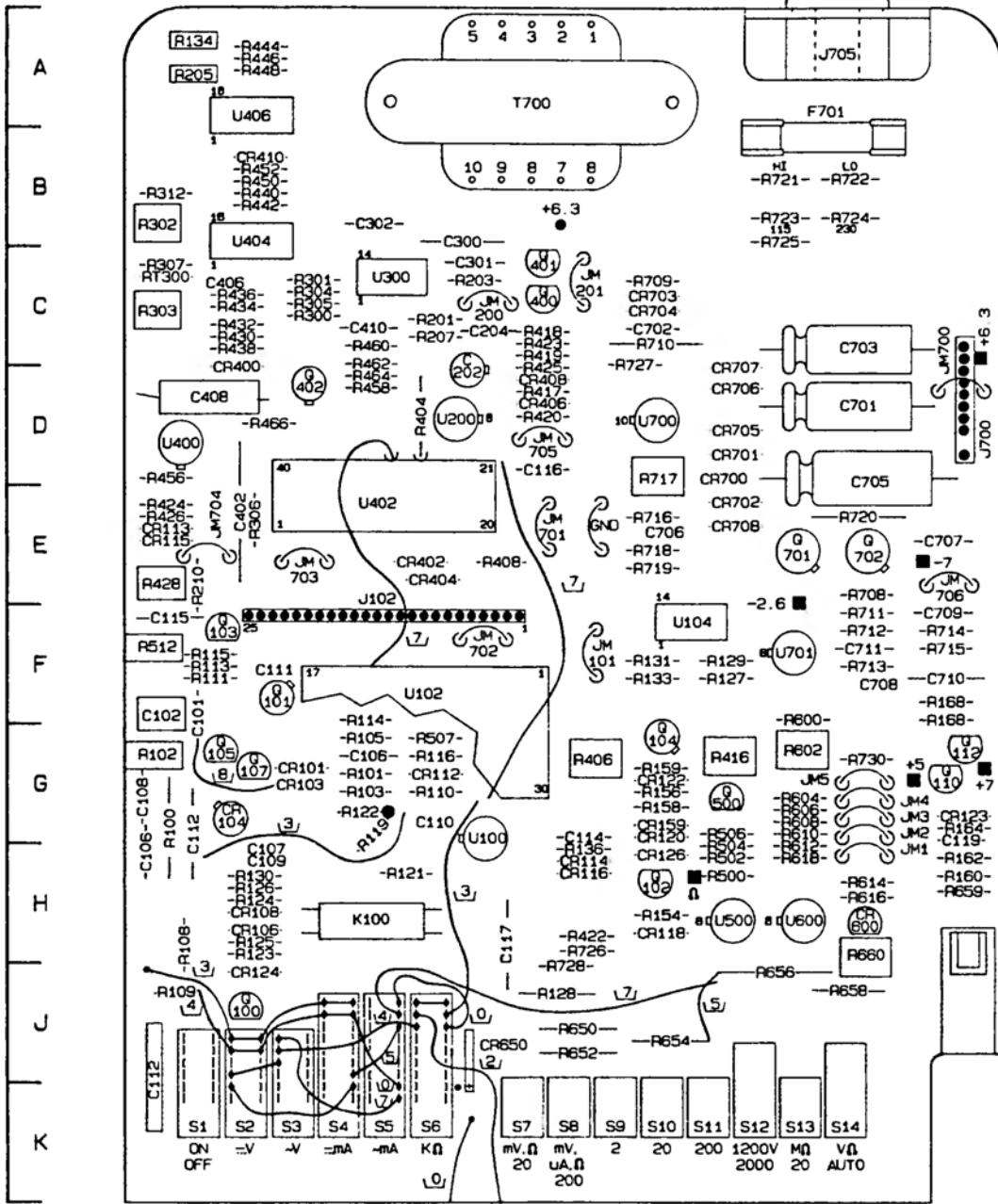

NOTE: ALL FLYING LEADS ARE WHITE UNLESS OTHERWISE MARKED

A1

03466-66501

COMPONENT LOCATOR FOR SCHEMATIC 5 (POWER SUPPLY)

Component	Location	Component	Location	Component	Location
C700	D6	CR706	D6	R711	F7
C701	D7	CR707	D6	R712	F7
C702	C5	CR708	E6	R713	F7
C703	C7			R714	F8
C705	D7	F701	A,B7	R715	F8
C706	E5,6			R716	E5
C707	E8	J700	C,D8	R718	E5
C708	F7	J705	A7	R719	E5
C709	F7			R720	E7
C710	F7	JM700	D8	R721	B6,7
C711	F7	JM706	E8	R722	B7
				R723	B6,7
CR701	D6	Q701	E6	R724	B7
CR702	E6	Q702	E7	R725	B6,7
CR703	C5			R727	C5
CR704	C5	R708	E7		
CR705	D6	R709	C5	T700	A4,5
		R710	C5		

COMPONENT LOCATOR FOR SCHEMATIC 5 (CHARGER CIRCUITRY)

Component	Location	Component	Location	Component	Location
C801	G3	CR813	C3	R808	G3
C802	E2	CR814	C3	R809	H4
C803	H4	CR815	C2	R810	E2
C805	G4	CR816	G4	R811	E2
C806	F4	CR817	H5	R812	E2
C807	E4			R813	F2
C808	C5	JM801	G6	R814	F2
C809	C2	JM802	E6	R815	E3
C810	C3			R816	H4
		Q801	D,E3	R817	G4
CR801	G3	Q803	G,H3	R818	G,H1
CR802	D2	Q804	D,E5	R819	G4
CR804	H4	Q805	D,E6	R820	F4
CR805	E4			R821	F4
CR806	G2	R801	D3	R822	E4
CR807	G2	R802	D3	R823	E5
CR808	G2	R803	D2	R824	E5
CR809	G2	R804	F3	R825	D5
CR810	F2	R805	H2	R826	D5
CR811	F3	R806	H2	R827	G3
CR812	C3	R807	F3		

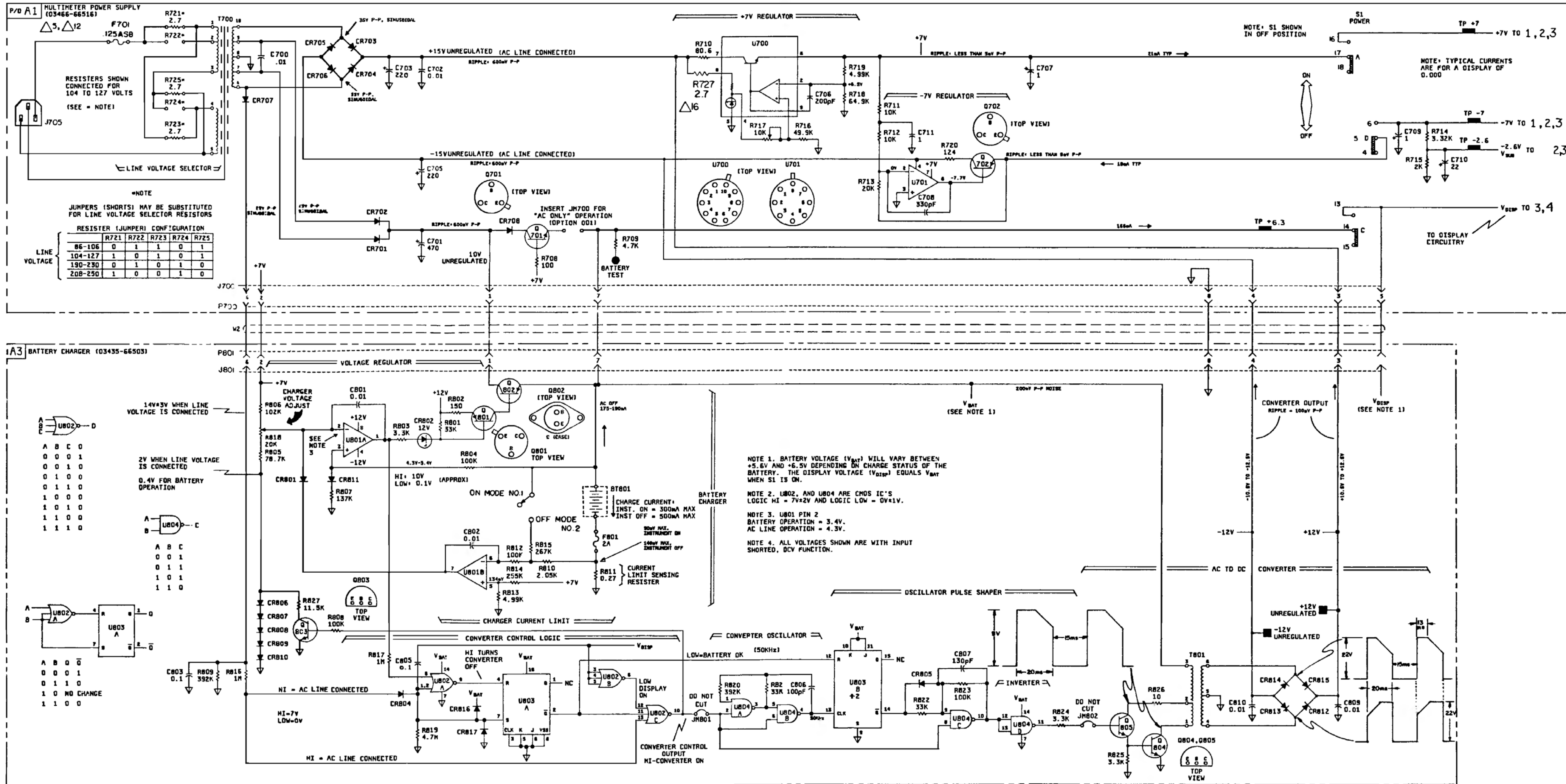

COPYRIGHT 1977 BY HEWLETT-PACKARD COMPANY

3466A-101

Figure 8-22. Power Supply and Charger Schematic  
8-37/8-38