



OPERATION AND SERVICE MANUAL

MODEL 4193A
VECTOR IMPEDANCE METER

SERIAL NUMBERS

This manual applies directly to instruments with serial numbers prefixed 2206J.

With changes described in Section VII, this manual also applies to instruments with serial numbers prefixed 2136J.

For additional important information about serial numbers, see INSTRUMENTS COVERED BY MANUAL in Section I.

© COPYRIGHT: YOKOGAWA-HEWLETT-PACKARD, LTD., 1983
9-1, TAKAKURA-CHO, HACHIOJI-SHI, TOKYO, JAPAN

Page 8-70, A7 Board Block Diagram
Change the left-hand table as follows:

FRO	FR1	FR
X	0	1kHz
0	1	10kHz
1	1	100kHz

X: irrelevent

Page 6-39, Table 6-3. Replaceable Parts,
Change the reference designation as follows:

A20CR3 → A20CR1
A20CR4 → A20CR2
A20CR5 → A20CR3
A20CR6 → A20CR4
A20CR7 → A20CR5
A20CR8 → A20CR6
A20CR9 → A20CR7
A20CR10 → A20CR8
A20CR11 → A20CR9

CHANGE 1

Page 2-2, Paragraph 2-12, line 4
Change the part number for a three prong to two prong
adapter to read:

HP Part No. 1251-8196

Page 3-3, Figure 3-1. Front Panel Features,
Change as follows;

- ⑫ PROBE Connector:
Probe cable connects to this connector.

CAUTION

WHEN CONNECTING THE PROBE TO THE 4193A,
CAREFULLY ALIGN THE PROBE AND SOCKET
GUIDES, FIRMLY SEAT THE PROBE IN ITS
SOCKET, AND TIGHTEN THE PROBE'S LOCK
NUT. THE PROBE SHOULD ONLY BE REMOVED
WHEN TRANSPORTING THE INSTRUMENT.

CHANGE 2

Page 6-34, Table 6-3. Replaceable Parts
Delete the following parts:

A17J1 to J5 1200-0541 SOCKET-IC 24-CONT DIP DIPSLDR

CHANGE 3

Page 8-69, Figure 8-43. A6 Board Assembly Schematic Diagram,
Change the figure as follows;

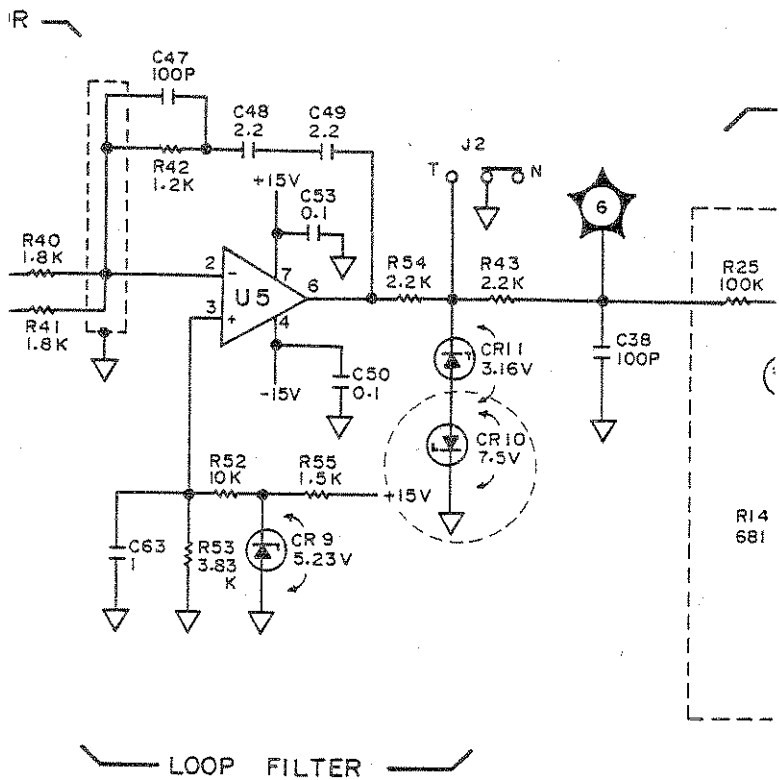

CHANGE 4

Page 2-4, Figure 2-3;
Change the figure as follows;

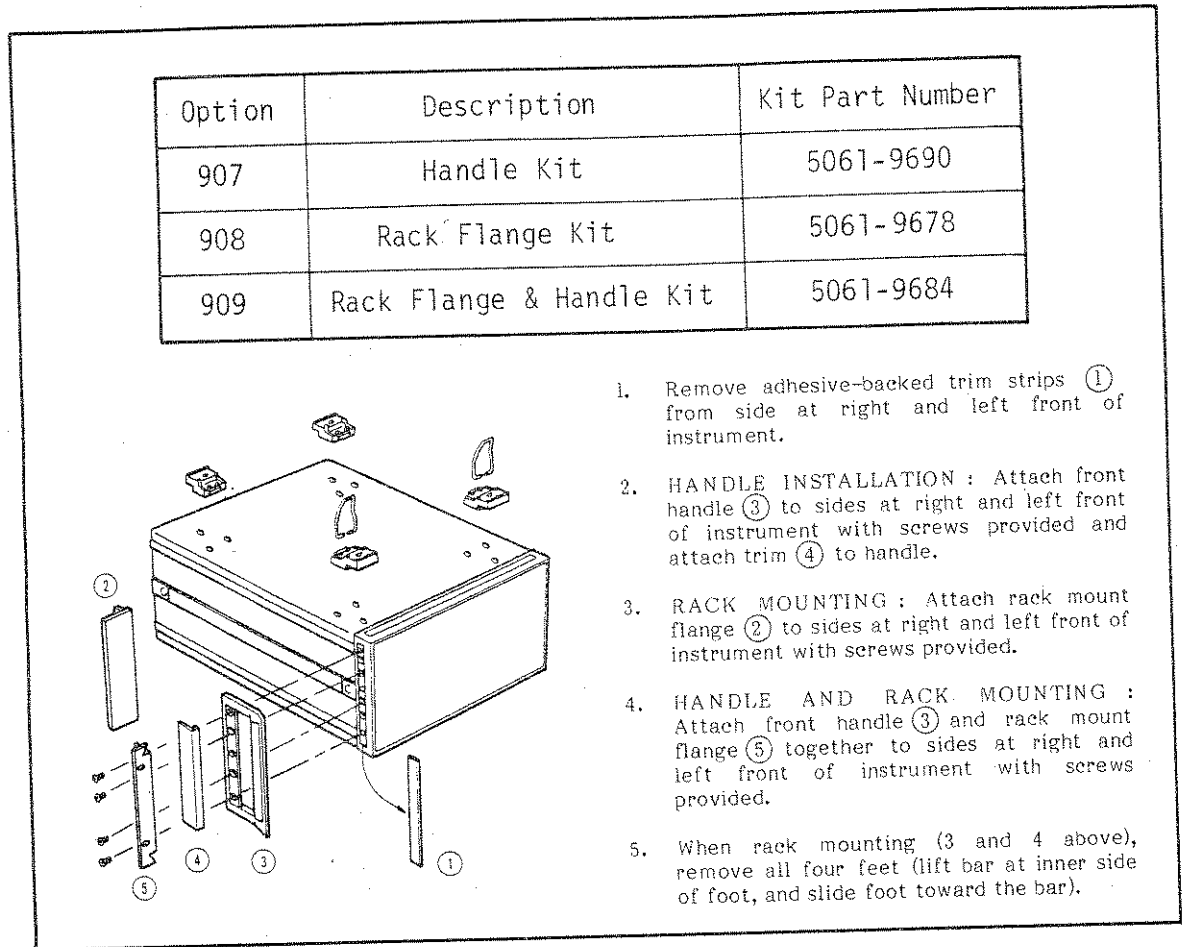

Figure 2-3. Rack Mount Kit.

SECTION I GENERAL INFORMATION

1-1. INTRODUCTION

1-2. This operation and service manual contains the information required to install, operate, test, adjust, and service the Hewlett-Packard Model 4193A Vector Impedance Meter. Figure 1-1 shows the instrument and supplied accessories. This section covers specifications, instrument identification, description, options, accessories, and other basic information.

1-3. Listed on the title page of this manual is a microfiche part number that can be used to order 4 x 6 inch microfilm transparencies of the manual. Each microfiche contains up to 60 photo-duplicates of the manual pages. The microfiche package also includes the latest manual changes supplement as well as all pertinent service notes. To order an additional manual, use the part number listed on the title page of this manual.

1-4. DESCRIPTION

1-5. The HP Model 4193A Vector Impedance Meter is a probe-type, fully automatic microprocessor-based test instrument designed for laboratory and production line applications. It measures and digitally displays impedance magnitude, $|Z|$, and phase angle, θ , of active or passive circuits, in-circuit components, discrete components at test frequencies from 400kHz to 110MHz with $10\text{m}\Omega$ (impedance) and 0.1° (phase) resolution. Frequency and measured impedance and phase are displayed on the front-panel with 4-digit and 3 1/2-digit resolution, respectively. Two measurement speeds are provided: NORMAL and HIGH SPEED. In NORMAL mode operation, the 4193A performs one measurement per second; in HIGH SPEED mode operation, it performs approximately seven measurements per second.



Figure 1-1. Model 4193A and Accessories.

SECTION I

1-6. The 4193A's built-in test signal synthesizer can be set with 1kHz (maximum) resolution to any frequency within the range of 400kHz to 110MHz for SPOT measurements, or it can be automatically or manually swept in one of two sweep modes: FULL and PARTIAL. In FULL SWEEP mode, frequency is logarithmically swept from 400kHz to 110MHz, and measurement is made at 43 frequency points. In PARTIAL SWEEP mode, frequency is swept from the selected START frequency to the selected STOP frequency. The number of measurement points is selectable at 100, 1000, or HIGH RESOLUTION. Frequency resolution is 1kHz, 10kHz, or 100kHz, depending on the selected frequency range. For measurements requiring higher frequency resolution, an external frequency synthesizer can be connected. Using this technique, 100Hz frequency resolution can be obtained over the 4193A's full frequency range, 400kHz to 110MHz.

1-7. Test frequency, auto-ranging, frequency sweep, introspective testing (SELF TEST), display, triggering, analog and HP-IB outputs, calculations, and all other instrument functions are microprocessor controlled. This microprocessor-based hardware design makes operation and measurement set-up simple.

1-8. The 4193A is equipped with complete HP-IB capabilities for remote control of all front-panel controls. This feature makes it possible to integrate the 4193A into a cost-efficient measurement system which increases DUT throughput, and improves circuit design efficiency. The 4193A is also equipped with X-Y Recorder outputs and pen lift control. Clear and accurate hard copies of the DUT's impedance-frequency or phase-frequency characteristics can be easily obtained with this capability, without an external controller.

1-9. To maximize the versatility of the 4193A, a wide selection of probe adapters and test fixtures is available. Thus, components of virtually any shape or size can be measured.

1-10. SPECIFICATIONS

1-11. Complete specifications of the Model 4193A Vector Impedance Meter are given in Table 1-1. These specifications are the performance standards or limits against which the instrument is tested. The test procedures for the specifications are covered in Section IV, Performance Tests. Table 1-2 lists supplemental performance characteristics. Supplemental performance characteristics are not specifications but are typical characteristics included as additional information for the

operator. When the 4193A Vector Impedance Meter is shipped from the factory, it meets the specifications listed in Table 1-1.

1-12. SAFETY CONSIDERATIONS

1-13. The Model 4193A Vector Impedance Meter has been designed to conform to the safety requirements of an IEC (International Electromechanical Committee) Safety Class I instrument and is shipped from the factory in a safe condition.

1-14. This operation and service manual contains information, cautions, and warnings which must be followed by the user to ensure safe operation and to maintain the instrument in a safe condition.

1-15. INSTRUMENTS COVERED BY MANUAL

1-16. Hewlett-Packard uses a two-section nine character serial number which is stamped on the serial number plate (Figure 1-2) attached to the instrument's rear-panel. The first four digits and the letter are the serial prefix and the last five digits are the suffix. The letter placed between the two sections identifies the country where the instrument was manufactured. The prefix is the same for all identical instruments; it changes only when a change is made to the instrument. The suffix, however, is assigned sequentially and is different for each instrument. The contents of this manual apply to instruments with the serial number prefix(es) listed under SERIAL NUMBERS on the title page.

1-17. An instrument manufactured after the printing of this manual may have a serial number prefix that is not listed on the title page. This unlisted serial number prefix indicates the instrument is different from those described in this manual. The manual for this new instrument may be accompanied by a yellow Manual Changes supplement or have a different manual part number. This supplement contains "change information" that explains how to adapt the manual to the newer instrument.

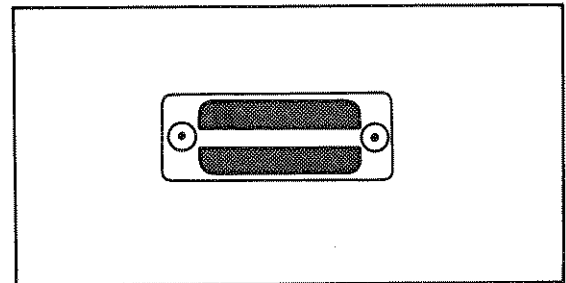

Figure 1-2. Serial Number Plate.

1-18. In addition to change information, the supplement may contain information for correcting errors (called Errata) in the manual. To keep this manual as current and accurate as possible, Hewlett-Packard recommends that you periodically request the latest Manual Changes supplement. The supplement for this manual is identified with this manual's print date and part number, both of which appear on the manual's title page. Complimentary copies of the supplement are available from Hewlett-Packard. If the serial prefix or number of an instrument is lower than that on the title page of this manual, see Section VII, Manual Changes.

1-19. For information concerning a serial number prefix that is not listed on the title page or in the Manual Change supplement, contact the nearest Hewlett-Packard office.

1-20. OPTIONS

1-21. Options are modifications to the standard instrument that implement the user's special requirements for minor functional changes. The 4193A has four options:

- Option 907: Front Handle Kit.
Furnishes Carrying handles for both ends of front-panel.
- Option 908: Rack Frange Kit.
Furnishes flanges for rack mounting for both ends of front-panel.

Option 909: Rack Flange and Front Handle Kit. Furnishes both front handles and rack flanges for instrument.

Option 910: An extra copy of the Operation and Service Manual.

Installation procedures for these options are given in Section II.

1-22. ACCESSORIES SUPPLIED

1-23. The Model 4193A VECTOR IMPEDANCE METER, along with its furnished accessories, is shown in Figure 1-1. The furnished accessories are also listed below:

Probe Kit..... HP Part No.
04193-87001

Power Cable HP Part No.
8120-1378

Fuse HP Part No.
2110-0304

Probe kit contents are listed in Table 1-3.

1-24. ACCESSORIES AVAILABLE

1-25. A test fixture adapter and three test fixtures are available to facilitate measurement on a wide range of discrete components. Also available is a calibration-standard set for calibration of the 4193A or similar probe-type instruments. A brief description of each available accessory is given in Table 1-4.

Table 1-1. Specifications: (Sheet 1 of 5)

SPECIFICATIONS

IMPEDANCE MAGNITUDE MEASUREMENT:

Range, Display, and Resolution:

MAGNITUDE RANGE	DISPLAY RANGE	DISPLAY (digit)	RESOLUTION
10Ω	00.00Ω to 19.99Ω	3 1/2	10mΩ
100Ω	000.0Ω to 199.9Ω	3 1/2	100mΩ
1kΩ	0.000kΩ to 1.999kΩ	3 1/2	1Ω
10kΩ	00.00kΩ to 19.99kΩ	3 1/2	10Ω
100kΩ	000.kΩ to 120.kΩ	2 1/2	1kΩ

Accuracy: See Table A.

Range Mode: Auto and manual (up-down).

IMPEDANCE PHASE MEASUREMENT:

Range and Resolution:

MAGNITUDE RANGE	DISPLAY RANGE	RESOLUTION
10Ω	180.0° to -180.0°	0.1°
100Ω	180.0° to -180.0°	0.1°
1kΩ	180.0° to -180.0°	0.1°
10kΩ	180.0° to -180.0°	0.1°
100kΩ	180.° to -180.°	1°

Accuracy: See Table A.

Table A. Accuracies

MAGNITUDE RANGE	Test Frequency (MHz)			
	0.4 to 1	1 to 10	10 to 40	40 to 110
10Ω	Z $\pm[(5.7 + \frac{0.56}{f})\% \text{ of reading} + 9 \text{ counts}]$	$\pm[6.3\% \text{ of reading} + 6 \text{ counts}]$	$\pm[(4.5 + 0.18f)\% \text{ of reading} + 4 \text{ counts}]$	$\pm[(4.5 + 0.18)\% \text{ of reading} + 4 \text{ counts}]$
	$\theta \pm(1.7 + \frac{1.8 + \frac{35}{2}}{f}) \text{ degrees}$	$\pm(3.3 + 0.20f + \frac{35}{2}) \text{ degrees}$	$\pm(3.3 + 0.20f + \frac{35}{2}) \text{ degrees}$	$\pm(3.3 + 0.20f + \frac{35}{2}) \text{ degrees}$
100Ω	Z $\pm[(2.4 + \frac{0.56}{f})\% \text{ of reading} + 4 \text{ counts}]$	$\pm[3.0\% \text{ of reading} + 4 \text{ counts}]$	$\pm[(2.6 + 0.037f)\% \text{ of reading} + 4 \text{ counts}]$	$\pm[(2.6 + 0.037f)\% \text{ of reading} + 4 \text{ counts}]$
	$\theta \pm(1.5 + \frac{1.9 + \frac{35}{2}}{f}) \text{ degrees}$	$\pm(3.3 + 0.035f + \frac{35}{2}) \text{ degrees}$	$\pm(3.3 + 0.035f + \frac{35}{2}) \text{ degrees}$	$\pm(3.3 + 0.035f + \frac{35}{2}) \text{ degrees}$
1kΩ	Z $\pm[(3.2 + \frac{0.56}{f})\% \text{ of reading} + 4 \text{ counts}]$	$\pm[3.7\% \text{ of reading} + 4 \text{ counts}]$	$\pm[(2.7 + 0.11f)\% \text{ of reading} + 4 \text{ counts}]$	$\pm[(2.7 + 0.11f)\% \text{ of reading} + 4 \text{ counts}]$
	$\theta \pm(1.6 + \frac{1.8 + \frac{35}{2}}{f}) \text{ degrees}$	$\pm(3.3 + 0.11f + \frac{35}{2}) \text{ degrees}$	$\pm(3.3 + 0.11f + \frac{35}{2}) \text{ degrees}$	$\pm(3.3 + 0.11f + \frac{35}{2}) \text{ degrees}$
10kΩ	Z $\pm[(2.9 + \frac{0.56}{f})\% \text{ of reading} + 4 \text{ counts}]$	$\pm[(3.2 + 0.29f)\% \text{ of reading} + 4 \text{ counts}]$	$\pm[(0.74 + 0.53f)\% \text{ of reading} + 4 \text{ counts}]$	
	$\theta \pm(1.8 + \frac{1.9 + \frac{35}{2}}{f}) \text{ degrees}$	$\pm(3.1 + 0.53f + \frac{35}{2}) \text{ degrees}$	$\pm(8.3 + 0.01f + \frac{35}{2}) \text{ degrees}$	
100kΩ*	Z $\pm[(3.3 + \frac{0.56}{f})\% \text{ of reading} + 4 \text{ counts}]$			
	$\theta \pm(3.0 + \frac{1.9 + \frac{35}{2}}{f}) \text{ degrees}$			

Where, f is test frequency in MHz, and Z is number of MAGNITUDE display counts. On the 100kΩ range, the small zero "0" is not counted in Z.

*: Measurement accuracy is not specified above 100kΩ.

Table I-1. Specifications (Sheet 2 of 5)

TEST FREQUENCY :**Range and Resolution :**

TEST FREQUENCY RANGE	RESOLUTION
0.400 to 9.999MHz	1kHz
10.00 to 99.99MHz	10kHz
100.0 to 110.0MHz	100kHz

Accuracy : $\pm 0.01\%$ of settingStability : ± 100 ppm (at 0 °C to 55 °C)**Full Frequency Sweep :**

Test frequency is automatically and logarithmically swept from 400kHz to 110MHz. Measurement is made at the following 43 frequency points.

400kHz, 455kHz, 500kHz, 600kHz, 700kHz, 800kHz, 900kHz, 1MHz, 1.2MHz, 1.4MHz, 1.6MHz, 1.8MHz, 2MHz, 2.333MHz, 2.666MHz, 3MHz, 3.5MHz, 4MHz, 4.5MHz, 5MHz, 6MHz, 7MHz, 8MHz, 9MHz, 10MHz, 12MHz, 14MHz, 16MHz, 18MHz, 20MHz, 23.33MHz, 26.66MHz, 30MHz, 35MHz, 40MHz, 45MHz, 50MHz, 60MHz, 70MHz, 80MHz, 90MHz, 100MHz, 110MHz.

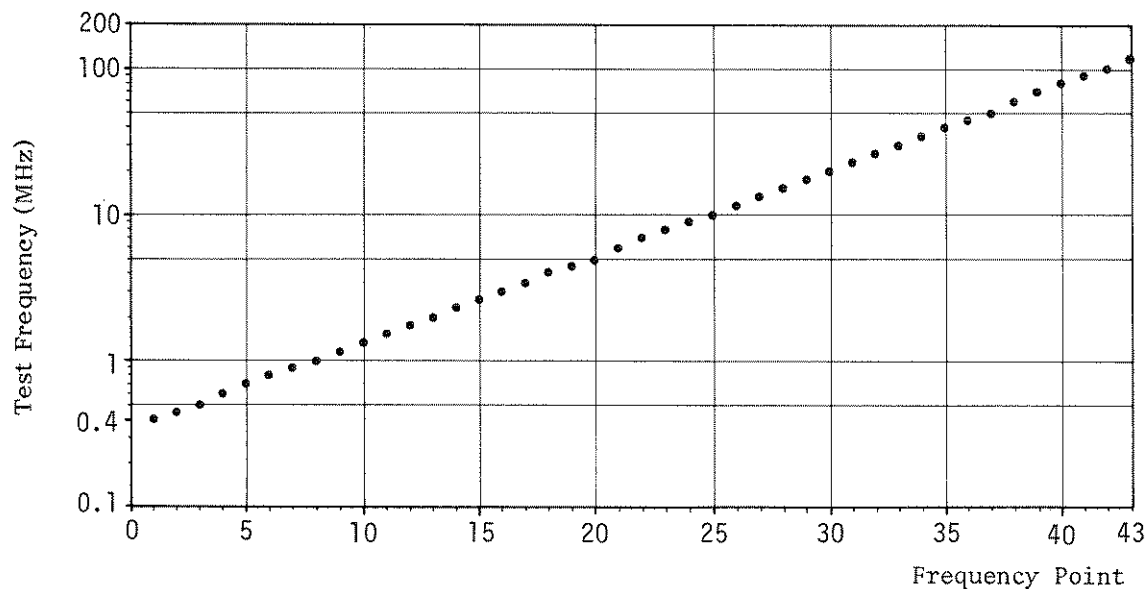

Figure A. Full-Sweep Frequency Points.

Table 1-1. Specifications (Sheet 3 of 5)

Partial Frequency Sweep :

Test frequency is automatically and linearly swept from the selected START FREQ. to the selected STOP FREQ. Number of measurement points is selectable with the STEPS keys--100, 1000, HIGH RESOLN.

100 : One hundred measurement points.

1000: One thousand measurement points.

HIGH RESOLN: Maximum step resolution for the selected sweep frequency range (START to STOP) is automatically selected.

MEASUREMENT TERMINAL: Two-terminal low-grounded probe, connected to instrument with a coaxial cable.

REFERENCE PLANE: Probe tip without probe pin.

RECORDER OUTPUTS: DC voltage outputs proportional to displayed values.

Magnitude Output: 0 to 1 Vdc proportional to displayed MAGNITUDE value
max 1 Vdc (at 2000 counts).

Phase Output: -1 Vdc to +1 Vdc proportional to displayed PHASE value
max ±1 Vdc (at ±1800 counts).

Frequency Output: 0 to 1 Vdc proportional to test frequency, as follows:

$$V_F = \frac{F_{SPOT} - F_{START}}{F_{STOP} - F_{START}} \text{ for manual and Partial Sweep}$$

$$V_F = \frac{\log (F_{SPOT} / F_{START})}{\log (F_{STOP} / F_{START})} \text{ for Full Sweep}$$

where, V_F is the analog output voltage.

0 Vdc and 1 Vdc for START frequency and STOP frequency, respectively.

PEN LIFT: TTL level signal. Goes LOW (PEN DOWN) at start of frequency sweep; goes HIGH (PEN UP) at completion of frequency sweep.

TRIGGER: Internal, external, or manual.

EXTERNAL TEST SIGNAL: External oscillator can be connected to obtain higher test frequency resolution.

Frequency: 400kHz to 110MHz.
Input Level: 0dBm to +5dBm.
Input Terminal: BNC connector.

Table 1-1. Specifications (Sheet 4 of 5)

SELF TEST: Checks the 4193A's basic operation and displays the test results. Initiated each time the instrument is turned on or when the SELF TEST mode is set by the SELF TEST key or via the HP-IB. Refer to paragraph 3-7.

HP-IB INTERFACE: Remote control and data output via the HP-IB (based on IEEE-Std-488 and ANSI-MCI).

Interface Capability : SH1, AH1, T5, L4, SR1, RL1, DC1, DT1, EI

Remote Control Function : All front-panel functions except LINE ON/OFF switch

Data Output : Measured impedance magnitude and phase values, test frequency value, and measurement setting information.

WARM-UP TIME : ≥ 60 minutes

AMBIENT TEMPERATURE : $23^{\circ}\text{C} \pm 5^{\circ}\text{C}$ (error limits double in magnitude and phase accuracies for 0°C to 55°C temperature range).

GENERAL

Operating Temperature : 0°C to $+55^{\circ}\text{C}$

Storage Temperature : -40°C to $+75^{\circ}\text{C}$

Humidity : $\leq 95\%$ at 40°C

Power Requirements : 100, 120, 220V $\pm 10\%$; 240V $+5\%$ -10% ;
48 to 66Hz; power consumption 150VA, maximum

Probe Cable Length : Approximately 150cm, measured from the front-panel to the probe tip.

Dimensions : 426mm (W) x 177mm (H) x 513mm (D) (16.77" x 7" x 20")

Weight : Approximately 18 kg.

OPTIONS

Option 907 : Front handle kit (P/N 5061-0090)

Option 908 : Rack flange kit (P/N 5061-0078)

Option 909 : Rack flange and handle kit (P/N 5061-0084)

Option 910 : Extra Manual

Table 1-1. Specifications (Sheet 5 of 5)

ACCESSORIES

Accessories Supplied :

Part Number	Accessory Name	Q'ty
04193-61151	Probe	1
04193-61152	Probe Adapter	1
04193-61153	Component Adapter	1
04193-61154	Ground Adapter	1
04193-61629	Ground Lead	1
04193-21008	Probe Socket	1
0360-2065	Spare Clips	3
04193-21023	Spare N-type Pins	5
16095-29005	Spare Pins	10
04193-60152	Probe Kit Case	1
1540-0692	Pin Case	3

Accessories Available :

16099A TEST FIXTURE ADAPTER: Connects Probe to one of three test fixtures, Model 16092A/16093A/16093B, for component measurement.

16345A PROBE TYPE CALIBRATION BOX: Contains 10 standards, SHORT/OPEN/10 Ω /50 Ω /100 Ω /180 Ω /1k Ω /1.8k Ω /10k Ω /5pF, for calibration of probe-type instruments.

16092A SPRING CLIP FIXTURE: Mounts atop the 16099A TEST FIXTURE ADAPTER. Used for discrete component measurements.

16093A BINDING POST FIXTURE: Mounts atop the 16099A TEST FIXTURE ADAPTER. Used for discrete component measurements.

16093B BINDING POST FIXTURE: Mounts atop the 16099A TEST FIXTURE ADAPTER. Used for discrete component measurements.

Table 1-2. General Information

SUPPLEMENTAL PERFORMANCE CHARACTERISTICS

MEASUREMENT TIME

Normal Mode : Approximately 1 sec. (typical)
 High Speed Mode : Approximately 150 msec. (typical)

FREQUENCY SETTling TIME

Approximately 5ms to 400ms

RANGING TIME

Approximately 1.2s

PROBE WITHSTAND VOLTAGE

DC : 50V maximum
 AC : 5Vrms maximum

OUTPUT IMPEDANCE

Approximately 25Ω with 0.2 μF series capacitance

RESIDUALS

Resistance in series with DUT (R_s) : $\leq 0.55\Omega$

Inductance in series with DUT (L_s) : $\leq (4.9 + \frac{10}{f})\text{nH}^{*2}$

Capacitance in parallel with DUT (C_p) : $\leq 0.11\text{pF}$

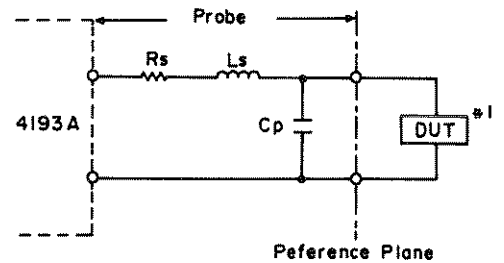

Note

*1: DUT includes the probe pin.

*2: f is test frequency in MHz.

TEST SIGNAL LEVEL:

MAGNITUDE RANGE	CURRENT Thru DUT (μArms)
10Ω	100
100Ω	100
1kΩ	100
10kΩ	50
100kΩ	10

Note : Current through the DUT is constant for each magnitude range.

Accuracy : $\pm 20\%$

RESIDUAL FM

100Hz_{p-p} for 1 thru 110MHz at 100Hz BW.

SKIP ERROR

10 counts maximum at 2.5MHz, 5MHz, and 10MHz.

Table 1-3. Probe Kit for 4193A

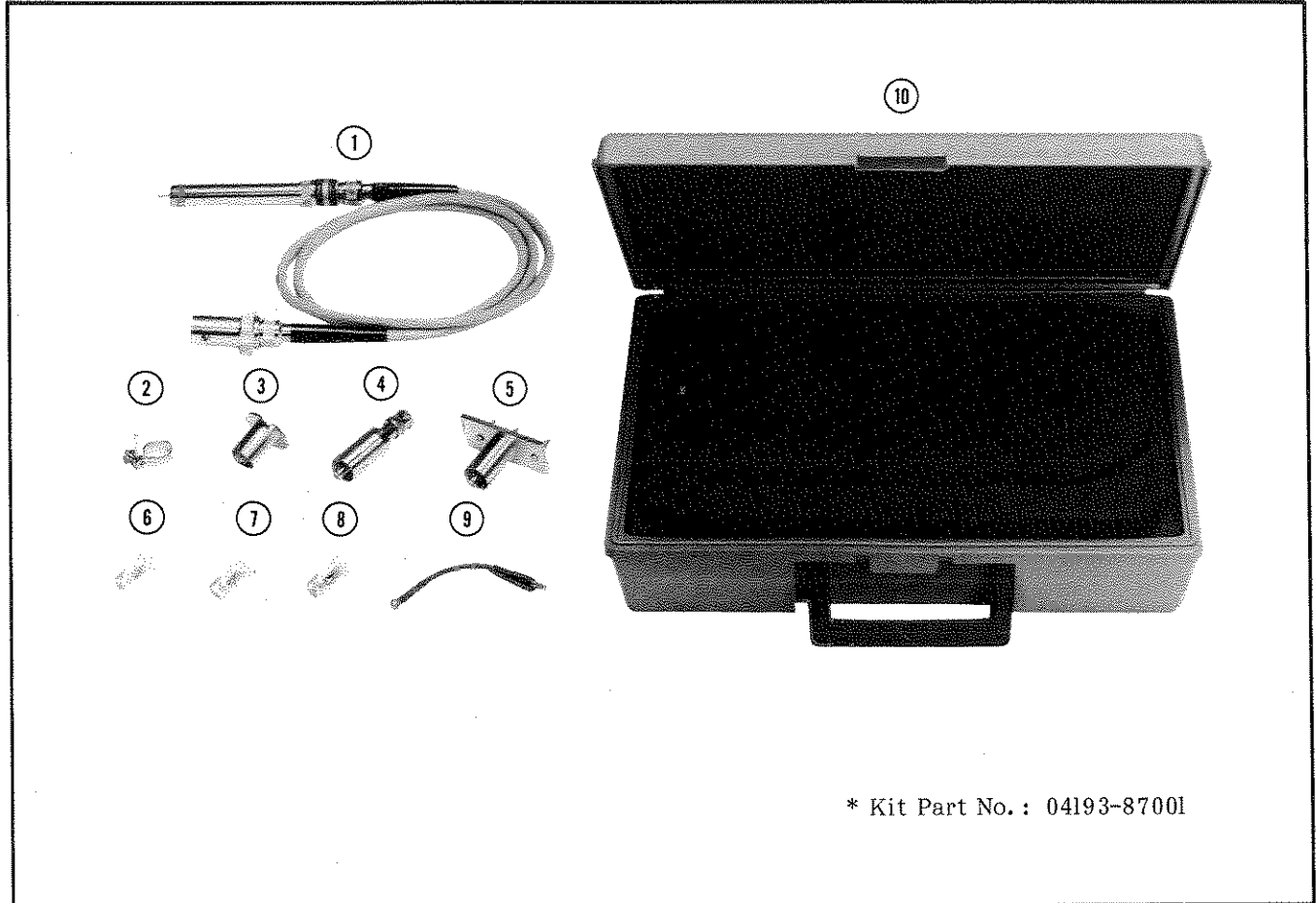

* Kit Part No. : 04193-87001

Reference	HP Part Number	Qty	Description
①	04193-61151	1	PROBE
②	04193-61154	1	GROUND ADAPTER
③	04193-21008	1	PROBE SOCKET
④	04193-61152	1	BNC ADAPTER
⑤	04193-61153	1	COMPONENT ADAPTER
⑥	04193-60153	1	SPARE N-TYPE PIN SET Contains five spare N-type pins (HP Part No.: 04193-21023)
⑦	16095-60012	1	SPARE PIN SET Contains ten spare N-type pins (HP Part No.: 16095-29005)
⑧	04193-60151	1	SPARE CLIP SET Contains three spare clips (HP Part No.: 0360-2065)
⑨	04193-61629	1	GROUND LEAD
⑩	04193-60152	1	PROBE KIT CASE

Table 1-4. Accessories Available (Sheet 1 of 3)

Model	Description
<p data-bbox="305 352 669 382">HP16092A Spring Clip Fixture</p> 	<p data-bbox="945 352 1469 520">Test Fixture (direct attachment type) for measurement of both axial and radial lead components and lead-less chip elements. Spring clip contacts are capable of holding samples of dimensions given below :</p>  <p data-bbox="945 871 1469 1039">A combined slide gauge provides direct readouts of the physical length of the sample tested. Usable frequency range is DC to 500MHz. The 16099A Test Fixture Adapter is necessary to connect the 4193A Probe.</p>
<p data-bbox="305 1192 690 1222">HP16093A Binding Post Fixture</p> 	<p data-bbox="945 1192 1469 1360">Test Fixture (direct attachment type) for measurement of both axial and radial lead miniature components. Two binding post terminals at an interval of 7mm on the terminal deck ensure optimum contact of terminals and sample leads.</p>  <p data-bbox="945 1795 1469 1900">Usable frequency range is DC to 250MHz. The 16099A Test Fixture Adapter is necessary to connect the 4193A Probe.</p>

Table I-4. Accessories Available (sheet 2 of 3)

Model	Description
<p data-bbox="272 344 657 373">HP16093B Binding Post Fixture</p> 	<p data-bbox="919 344 1442 485">Test Fixture (direct attachment type) for general measurement of both axial and radial lead components. Three binding post terminals are located on the terminal deck as shown below :</p>  <p data-bbox="922 974 1446 1087">Usable frequency range is DC to 125MHz. The 16099A Test Fixture Adapter is necessary to connect the 4193A Probe.</p>
<p data-bbox="277 1150 683 1180">HP 16099A Test Fixture Adapter</p> 	<p data-bbox="922 1150 1446 1262">Test Fixture Adapter for connecting the 4193A probe to one of the three available test fixtures—16092A, 16093A, and 16093B.</p> <p data-bbox="922 1289 1446 1377">Note: The 16099A and each of the available test fixtures must be ordered separately.</p> <ul style="list-style-type: none"> <li data-bbox="976 1528 1442 1558">① :HP16092A SPRING CLIP FIXTURE <li data-bbox="976 1577 1455 1606">② :HP16093A BINDING POST FIXTURE <li data-bbox="976 1625 1455 1654">③ :HP16093B BINDING POST FIXTURE

Table 1-4. Accessories Available (sheet 3 of 3)

Model	Description
<p data-bbox="305 346 779 378">HP16345A Probe Type Calibration Box</p> 	<p data-bbox="943 346 1469 573">Calibration standard for performance testing and adjustment of the 4193A. Includes ten probe-insertable standards : OPEN, SHORT, 10Ω, 50Ω, 100Ω, 180Ω, 1kΩ, 1.8kΩ, 10kΩ, and 5pF. If a standard is damaged or fails to perform properly, contact your nearest Hewlett-Packard Sales and Service Office.</p> <p data-bbox="943 604 1469 636">Dimensions : 310(W)x80(H)x205(D) [mm]</p> <p data-bbox="943 688 1364 720">Weight : Approximately 2.1kg</p>

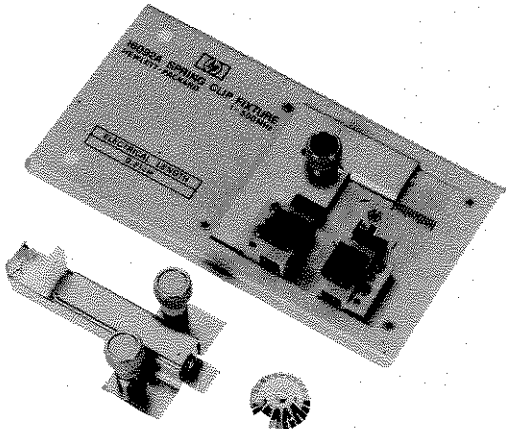
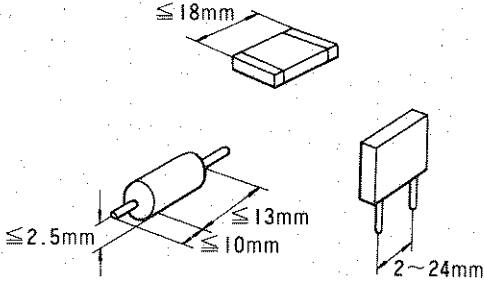
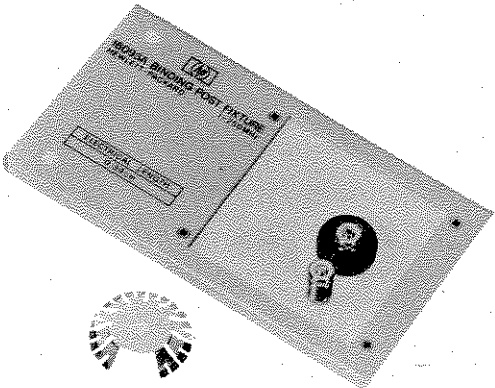
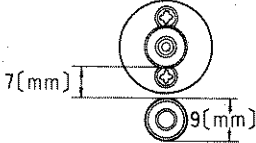
SECTION II INSTALLATION

2-1. INTRODUCTION

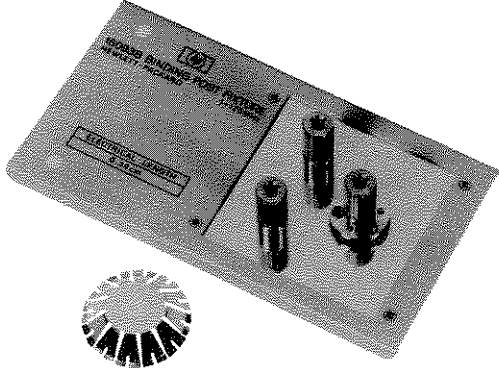
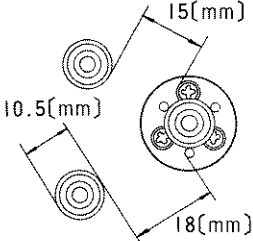
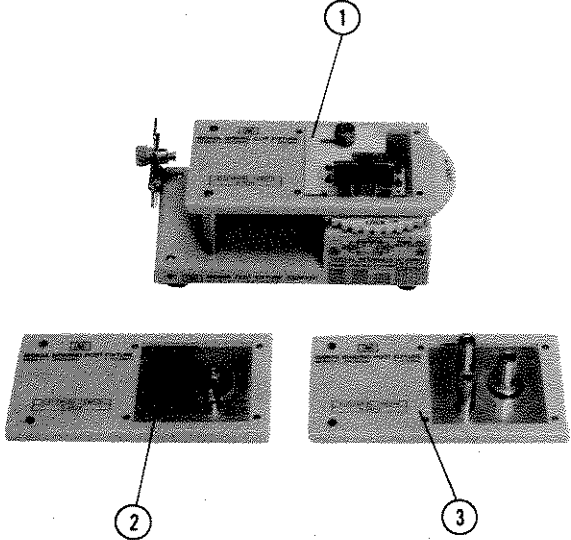
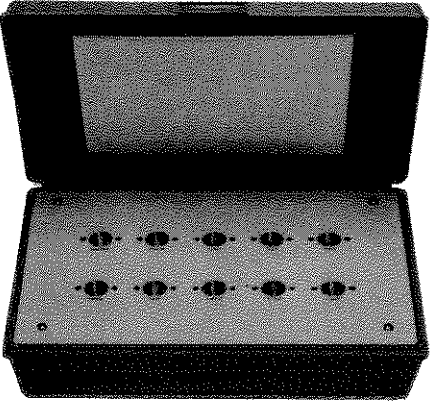
2-2. This section provides installation instructions for the Model 4193A Vector Impedance Meter. This section also includes information on initial inspection and damage claims, preparation for using the 4193A, packaging, storage, and shipment.

2-3. INITIAL INSPECTION

2-4. The 4193A Vector Impedance Meter, as shipped from the factory, meets all the specifications listed in Table 1-1. On receipt, inspect the shipping container for damage. If the shipping container or cushioning material is damaged, notify the carrier as well as the nearest Hewlett-Packard office and be sure to keep the shipping materials for carrier's inspection until the contents of the shipment have been checked for completeness and the instrument has been checked mechanically and electrically. The contents of the shipment should be as shown in Figure 1-1. The procedures for checking the general electrical operation are given in Section III (Paragraph 3-7 SELF TEST) and the procedures for checking the 4193A Vector Impedance Meter against its specifications are given in Section IV. First, do the self test. If the 4193A Vector Impedance Meter is electrically questionable, then do the Performance Tests to determine whether the 4193A has failed or not.

If the contents are incomplete, if there is mechanical damage or defects (scratches, dents, broken switches, etc.), or if the performance does not meet the self test or performance tests, notify the nearest Hewlett-Packard office (see list at back of this manual). The HP office will arrange for repair or replacement without waiting for claim settlement.

2-5. PREPARATION FOR USE

2-6. POWER REQUIREMENTS

2-7. The 4193A requires a power source of 100, 120, 220Volts ac +10%, or 240Volts ac +5%-10%, 48 to 66Hz single phase; power consumption is 150VA maximum.

WARNING

IF THE INSTRUMENT IS TO BE ENERGIZED VIA AN EXTERNAL AUTOTRANSFORMER FOR VOLTAGE REDUCTION, BE SURE THAT THE COMMON TERMINAL IS CONNECTED TO THE NEUTRAL POLE OF THE POWER SUPPLY.

2-8. Line Voltage and Fuse Selection

CAUTION

BEFORE TURNING THE 4193A LINE SWITCH TO ON, VERIFY THAT THE INSTRUMENT IS SET TO THE VOLTAGE OF THE POWER TO BE SUPPLIED.

2-9. Figure 2-1 provides instructions for line voltage and fuse selection. The line voltage selection switch and the proper fuse are factory installed for 100 or 120 volts ac operation.

CAUTION

USE PROPER FUSE FOR LINE VOLTAGE SELECTED.

CAUTION

MAKE SURE THAT ONLY FUSES FOR THE REQUIRED RATED CURRENT AND OF THE SPECIFIED TYPE ARE USED FOR REPLACEMENT. THE USE OF MENDED FUSES AND THE SHORT-CIRCUITING OF FUSE-HOLDERS MUST BE AVOIDED.

2-10. POWER CABLE

2-11. To protect operating personnel, the National Electrical Manufacturer's Association (NEMA) recommends that the instrument panel and cabinet be grounded. The Model 4193A is equipped with a three-conductor power cable which, when plugged into an appropriate receptacle, grounds the instrument. The offset pin on the power cable is the ground wire.

SECTION II

2-12. To preserve the protection feature when operating the instrument from a two contact outlet, use a three prong to two prong adapter (HP Part No. 1251-0048) and connect the green pigtail on the adapter to power line ground.

CAUTION

THE MAINS PLUG MUST ONLY BE INSERTED IN A SOCKET OUTLET PROVIDED WITH A PROTECTIVE EARTH CONTACT. THE PROTECTIVE ACTION MUST NOT BE NEGATED BY THE USE OF AN EXTENSION CORD (POWER CABLE) WITHOUT PROTECTIVE CONDUCTOR (GROUNDING).

2-13. Figure 2-2 shows the available power cords, which may be used in various countries including the standard power cord furnished with the instrument. HP Part number, applicable standards for power plug, power cord color, electrical characteristics and countries using each power cord are listed in the figure. If assistance is needed for selecting the correct power cable, contact the nearest Hewlett-Packard office.

2-14. OPERATING ENVIRONMENT

2-15. Temperature. The instrument may be operated in temperatures from 0°C to +55°C.

2-16. Humidity. The instrument may be operated in environments with relative

humidities to 90% at 40°C. However, the instrument should be protected from temperature extremes which cause condensation within the instrument.

2-17. INSTALLATION INSTRUCTIONS

2-18. The HP Model 4193A can be operated on the bench or in a rack mount. The 4193A is ready for bench operation as shipped from the factory. For bench operation a two-leg instrument stand is used. For use, the instrument stands are designed to be pulled towards the front of instrument.

2-19. Installation of Options 907, 908 and 909

2-20. The 4193A can be installed in a rack and be operated as a component of a measurement system. Rack mounting information for the 4193A is presented in Figure 2-3.

2-21. STORAGE AND SHIPMENT

2-22. ENVIRONMENT

2-23. The instrument may be stored or shipped in environments within the following limits:

Temperature -40 °C to +75 °C
 Humidity to 95% at 40 °C

The instrument should be protected from temperature extremes which cause condensation inside the instrument.

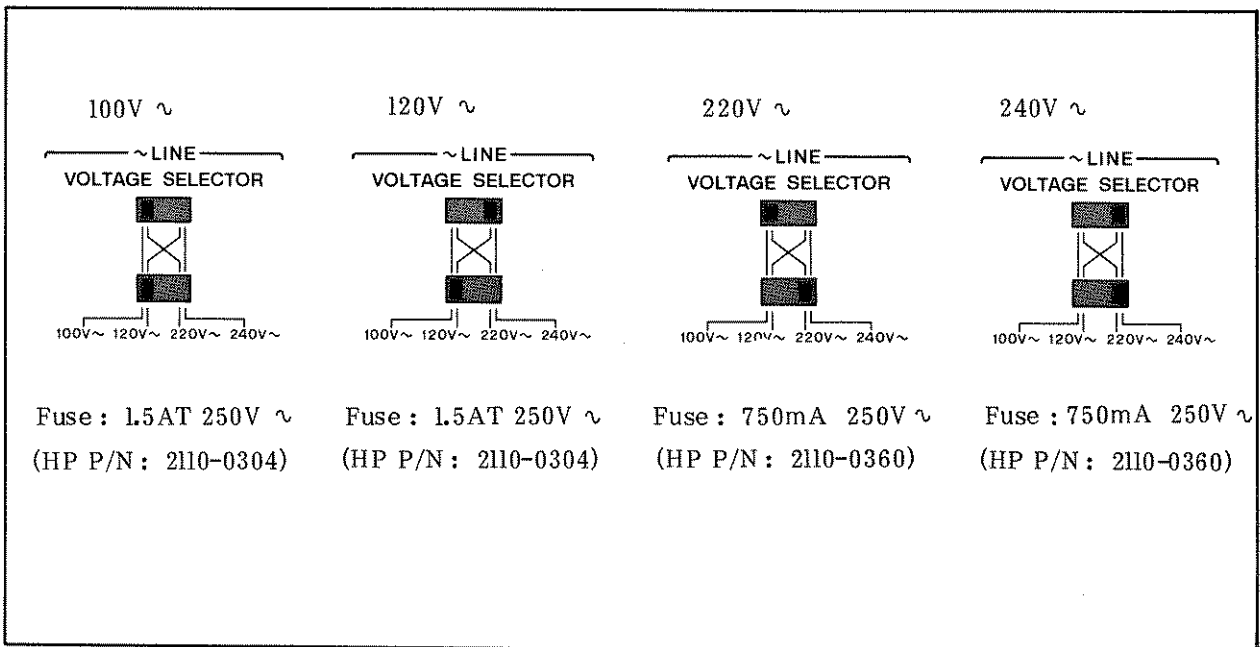

Figure 2-1. Voltage and Fuse Selection.

<p>OPTION 900 United Kingdom</p>  <p>Plug : BS 1363A, 250V Cable : HP 8120-1351</p>	<p>OPTION 901 Australia/New Zealand</p>  <p>Plug : NZSS 198/AS C112, 250V Cable : HP 8120-1369</p>
<p>OPTION 902 European Continent</p>  <p>Plug : CEE-VII, 250V Cable : HP 8120-1689</p>	<p>OPTION 903 U.S./Canada</p>  <p>Plug : NEMA 5-15P, 125V, 15A Cable : HP 8120-1378</p>
<p>OPTION 905* Any country</p>  <p>Plug : CEE 22-VI, 250V Cable : HP 8120-1396</p>	<p>OPTION 906 Switzerland</p>  <p>Plug : SEV 1011.1959-24507 Type 12, 250V Cable : HP 8120-2104</p>
<p>OPTION 912 Denmark</p>  <p>Plug : DHCR 107, 220V Cable : HP 8120-2956</p>	<p>* Plug option 905 is frequently used for interconnecting system components and peripherals.</p> <p>NOTE: Each option number includes a 'family' of cords and connectors of various materials and plug body configurations (straight, 90 ° etc.)</p>

Figure 2-2. Power Cables Supplied.

SECTION II

2-24. PACKAGING

2-25. Original Packaging. Containers and materials identical to those used in factory packaging are available from Hewlett-Packard. If the instrument is being returned to Hewlett-Packard for servicing, attach a tag indicating the type of service required, return address, model number, and full serial number. Also mark the container FRAGILE to assure careful handling. In any correspondence, refer to the instrument by model number and full serial number.

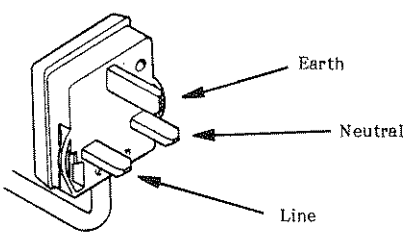
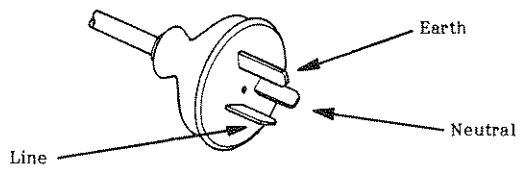
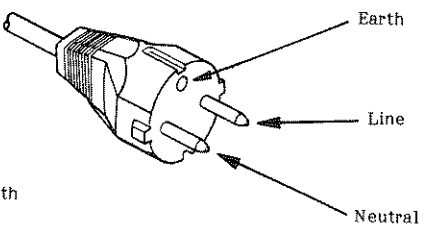
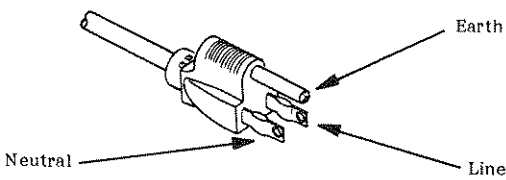
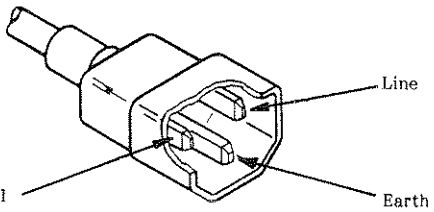
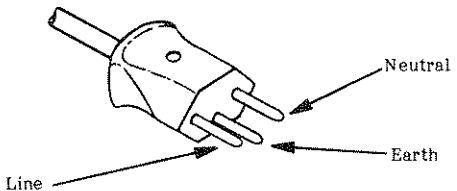
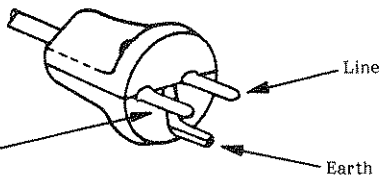
2-26. Other Packaging. The following general instructions should be used for re-packing with commercially available materials:

- a. Wrap instrument in heavy paper or plastic. If shipping to Hewlett-Packard office or service center, attach tag indicating type of service required, return address, model number, and full serial number.

- b. Use strong shipping container. A double-wall carton made of 350 pound test material is adequate.
- c. Use enough shock absorbing material (3 to 4 inch layer) around all sides of instrument to provide firm cushion and prevent movement inside container. Protect control panel with cardboard.
- d. Seal shipping container securely.
- e. Mark shipping container FRAGILE to ensure careful handling.
- f. In any correspondence, refer to instrument by model number and full serial number.

Option	Kit Part Number	Parts Included	Part Number	Q'ty	Remarks
907	Handle Kit 5061-0090	Front Handle Trim Strip X8-32 x 3/8 Screw	③ 5060-9900 ④ 5020-8897 2510-0195	2 2 6	9.525mm
908	Rack Flange Kit 5061-0078	Rack Mount Flange X8-32 x 3/8 Screw	② 5020-8863 2510-0193	2 6	9.525mm
909	Rack Flange & Handle Kit 5061-0084	Front handle Rack Mount Flange X8-32 x 3/8 Screw	③ 5060-9900 ⑤ 5020-8875 2510-0194	2 2 6	15.875mm

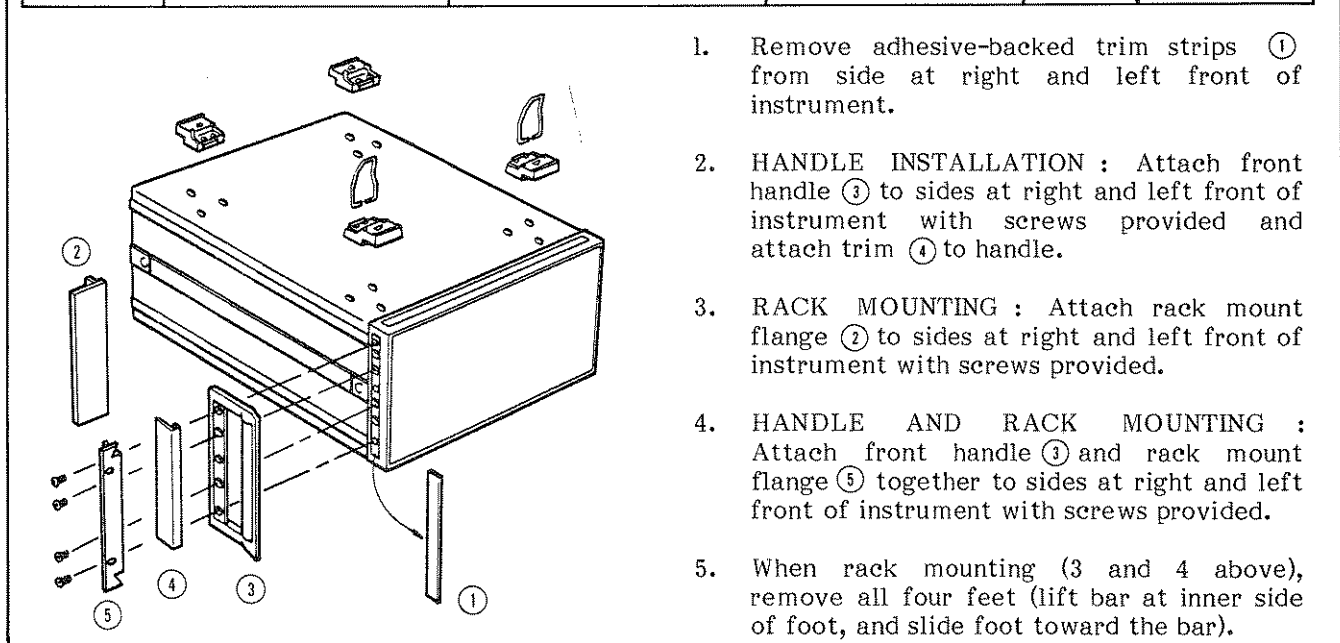

1. Remove adhesive-backed trim strips ① from side at right and left front of instrument.
2. HANDLE INSTALLATION : Attach front handle ③ to sides at right and left front of instrument with screws provided and attach trim ④ to handle.
3. RACK MOUNTING : Attach rack mount flange ② to sides at right and left front of instrument with screws provided.
4. HANDLE AND RACK MOUNTING : Attach front handle ③ and rack mount flange ⑤ together to sides at right and left front of instrument with screws provided.
5. When rack mounting (3 and 4 above), remove all four feet (lift bar at inner side of foot, and slide foot toward the bar).

Figure 2-3. Rack Mount Kit.

SECTION III OPERATION

3-1. INTRODUCTION

3-2. This section provides all the information necessary to operate the Model 4193A Vector Impedance Meter. Included are descriptions of the front- and rear-panels, displays, lamps and connectors; discussions on operating procedures and measuring techniques for various applications; and instructions on the instrument's SELF TEST function. Warnings, Cautions, and Notes are given throughout; they should be observed to insure the safety of the operator and the serviceability of the instrument.

WARNING

BEFORE THE INSTRUMENT IS SWITCHED ON, ALL PROTECTIVE EARTH TERMINALS, EXTENSION CORDS, AUTO-TRANSFORMERS AND DEVICES CONNECTED TO IT SHOULD BE CONNECTED TO A PROTECTIVE EARTH GROUNDED SOCKET. ANY INTERRUPTION OF THE PROTECTIVE EARTH GROUNDING WILL CAUSE A POTENTIAL SHOCK HAZARD THAT COULD RESULT IN SERIOUS PERSONAL INJURY.

ONLY FUSES WITH THE REQUIRED RATED CURRENT AND OF THE SPECIFIED TYPE SHOULD BE USED. DO NOT USE REPAIRED FUSES OR SHORTED FUSEHOLDERS. TO DO SO COULD CAUSE A SHOCK OR FIRE HAZARD.

CAUTION

BEFORE THE INSTRUMENT IS SWITCHED ON, IT MUST BE SET TO THE VOLTAGE OF THE POWER SOURCE (MAINS), OR DAMAGE TO THE INSTRUMENT MAY RESULT.

3-3. OPERATING INSTRUCTIONS

3-4. Operating instructions for the instrument's basic capabilities are given in paragraphs 3-5 through 3-44. Operating instructions for the instrument's extended capabilities (remote operation via the HP-IB, X-Y Recorder Outputs, and External Oscillator) are covered in paragraphs 3-45 through 3-80.

3-5. PANEL FEATURES

3-6. Front- and rear-panel features for the 4193A are described in Figure 3-1 and Figure 3-2, respectively. More detailed information on the panel displays and controls is given in paragraph 3-7 and below.

3-7. SELF TEST

3-8. The 4193A is equipped with an automatic self-diagnostic function that can be initiated at any time to confirm normal operation of the instrument's basic functions. SELF TEST can be initiated from the front-panel by pressing the SELF TEST key or via HP-IB remote control (program code S1). When SELF TEST is initiated (key indicator lamp is on), eight tests of the instrument's digital section are performed and the results (pass code or one of the error codes listed in Table 3-5) are displayed on the FREQUENCY display. If no errors are detected, pass codes P1 through P7, P40, and PASS will be sequentially displayed on the FREQUENCY display and the instrument will then return to normal measurement mode (SELF TEST key indicator lamp off). If an error is detected, the corresponding error code--listed in Table 3-5--will be displayed on the FREQUENCY display and SELF TEST will stop. Error code E-61 is not an instrument failure. Refer to Table 3-3 for the cause and remedy. If the instrument fails SELF TEST (an error code other than E-61 is displayed), contact the nearest Hewlett-Packard Service Office. A list of addresses is provided at the back of this manual.

Note

An abbreviated SELF TEST is automatically performed each time the instrument is turned on. Only error codes--if an error is detected--PASS or FAIL, and the instrument's HP-IB address are displayed at the end of this SELF TEST.

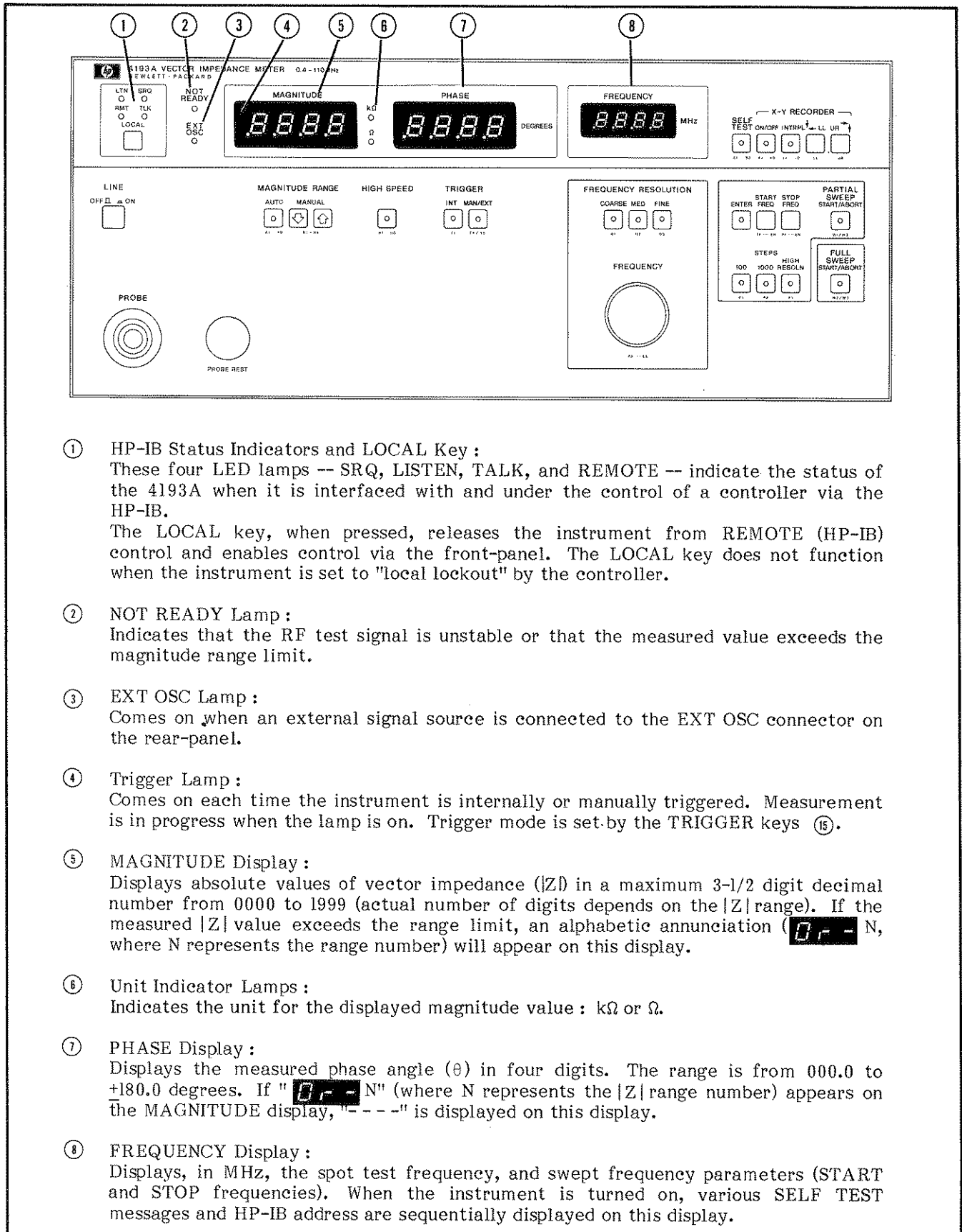

- ① **HP-IB Status Indicators and LOCAL Key :**
These four LED lamps -- SRQ, LISTEN, TALK, and REMOTE -- indicate the status of the 4193A when it is interfaced with and under the control of a controller via the HP-IB.
The LOCAL key, when pressed, releases the instrument from REMOTE (HP-IB) control and enables control via the front-panel. The LOCAL key does not function when the instrument is set to "local lockout" by the controller.
- ② **NOT READY Lamp :**
Indicates that the RF test signal is unstable or that the measured value exceeds the magnitude range limit.
- ③ **EXT OSC Lamp :**
Comes on when an external signal source is connected to the EXT OSC connector on the rear-panel.
- ④ **Trigger Lamp :**
Comes on each time the instrument is internally or manually triggered. Measurement is in progress when the lamp is on. Trigger mode is set by the TRIGGER keys ⑮.
- ⑤ **MAGNITUDE Display :**
Displays absolute values of vector impedance ($|Z|$) in a maximum 3-1/2 digit decimal number from 0000 to 1999 (actual number of digits depends on the $|Z|$ range). If the measured $|Z|$ value exceeds the range limit, an alphabetic annunciation (**Dr - N**, where N represents the range number) will appear on this display.
- ⑥ **Unit Indicator Lamps :**
Indicates the unit for the displayed magnitude value : $k\Omega$ or Ω .
- ⑦ **PHASE Display :**
Displays the measured phase angle (θ) in four digits. The range is from 000.0 to +180.0 degrees. If "**Dr - N**" (where N represents the $|Z|$ range number) appears on the MAGNITUDE display, " - - - -" is displayed on this display.
- ⑧ **FREQUENCY Display :**
Displays, in MHz, the spot test frequency, and swept frequency parameters (START and STOP frequencies). When the instrument is turned on, various SELF TEST messages and HP-IB address are sequentially displayed on this display.

Figure 3-1. Front Panel Features (Sheet 1 of 4).

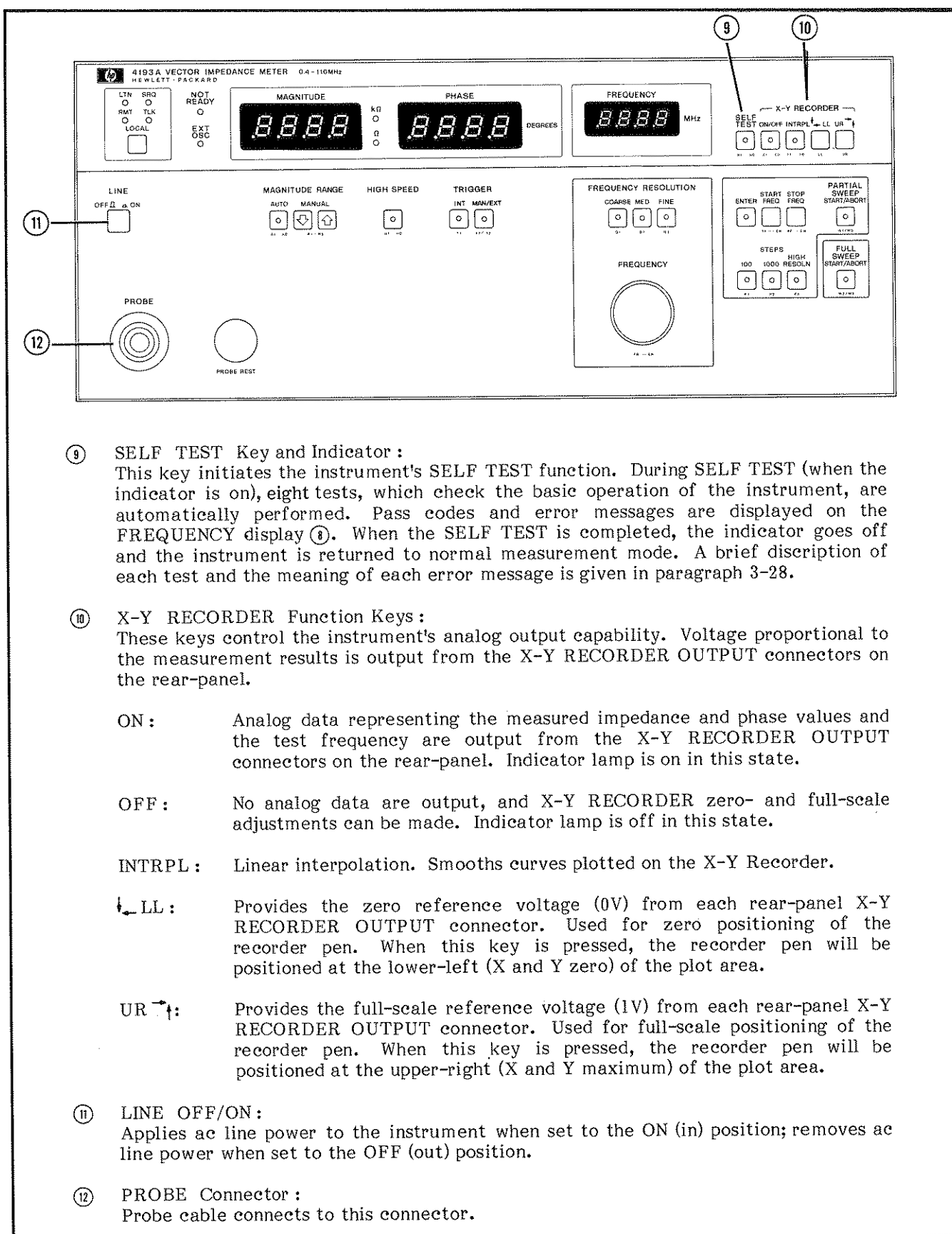

- ⑨ SELF TEST Key and Indicator :
This key initiates the instrument's SELF TEST function. During SELF TEST (when the indicator is on), eight tests, which check the basic operation of the instrument, are automatically performed. Pass codes and error messages are displayed on the FREQUENCY display ④. When the SELF TEST is completed, the indicator goes off and the instrument is returned to normal measurement mode. A brief description of each test and the meaning of each error message is given in paragraph 3-28.
- ⑩ X-Y RECORDER Function Keys :
These keys control the instrument's analog output capability. Voltage proportional to the measurement results is output from the X-Y RECORDER OUTPUT connectors on the rear-panel.
- ON : Analog data representing the measured impedance and phase values and the test frequency are output from the X-Y RECORDER OUTPUT connectors on the rear-panel. Indicator lamp is on in this state.
- OFF : No analog data are output, and X-Y RECORDER zero- and full-scale adjustments can be made. Indicator lamp is off in this state.
- INTRPL : Linear interpolation. Smooths curves plotted on the X-Y Recorder.
- LL : Provides the zero reference voltage (0V) from each rear-panel X-Y RECORDER OUTPUT connector. Used for zero positioning of the recorder pen. When this key is pressed, the recorder pen will be positioned at the lower-left (X and Y zero) of the plot area.
- UR : Provides the full-scale reference voltage (1V) from each rear-panel X-Y RECORDER OUTPUT connector. Used for full-scale positioning of the recorder pen. When this key is pressed, the recorder pen will be positioned at the upper-right (X and Y maximum) of the plot area.
- ⑪ LINE OFF/ON :
Applies ac line power to the instrument when set to the ON (in) position; removes ac line power when set to the OFF (out) position.
- ⑫ PROBE Connector :
Probe cable connects to this connector.

Figure 3-1. Front Panel Features (Sheet 2 of 4).

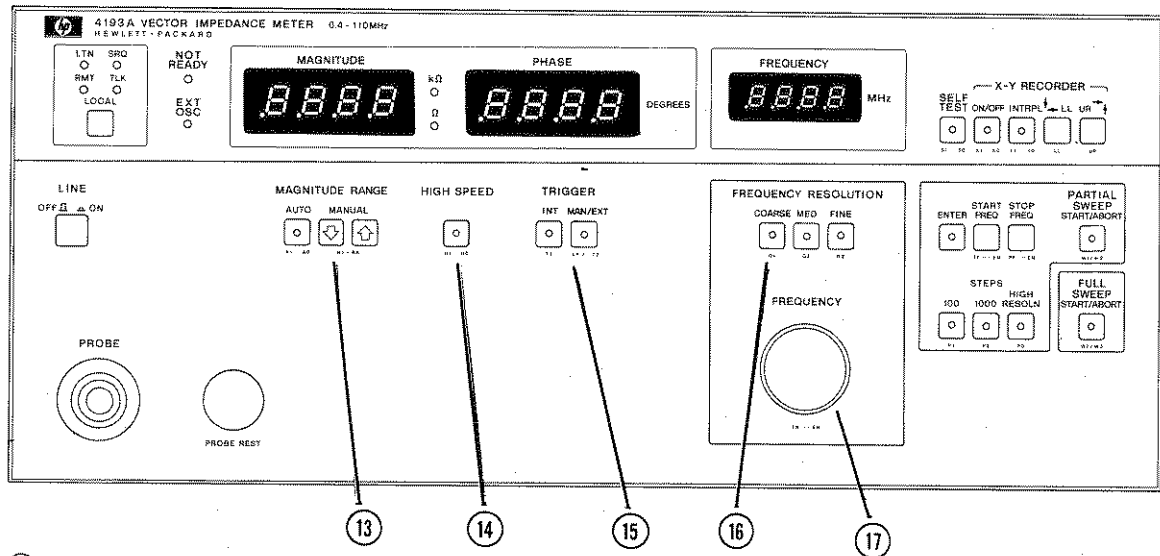

⑬ **MAGNITUDE RANGE Keys :**

These keys are used to select the measurement range.

AUTO : When indicator lamp is on, optimum range for the DUT's impedance is automatically selected.

MANUAL : When the AUTO indicator lamp is off, these keys are used to select the measurement range. Once selected, the range will not change even if the sample is changed. Manual ranging is done by pressing the DOWN (⏴) key or the UP (⏵) key.

⑭ **HIGH SPEED MODE Key :**

Shortens the measurement time and increases the measurement cycle speed.

⑮ **TRIGGER Keys :**

These keys select the trigger mode.

INT : Measurement is triggered by the instrument's internal trigger signal.

MAN/EXT : Measurement is triggered each time this key is pressed, and measurement data are held until the next time the key is pressed. Or the 4193A is triggered by an external trigger.

Note

An external trigger signal can be applied from the rear panel connector. External triggering is performed at the trailing edge of the applied TTL pulse. See paragraph 3-32.

⑯ **FREQ. RESOLUTION Keys :**

Sets the incremental/decremental value for frequency changes made with the Test Frequency Control Dial ⑰. Incremental/decremental value for COARSE, MED, and FINE is 100 counts, 10 counts, and 1 count, respectively.

⑰ **Test Frequency Control Dial :**

Changes the test frequency. Rotating the dial clockwise increases the frequency; rotating it counterclockwise decreases the frequency.

Figure 3-1. Front Panel Features (Sheet 3 of 4).

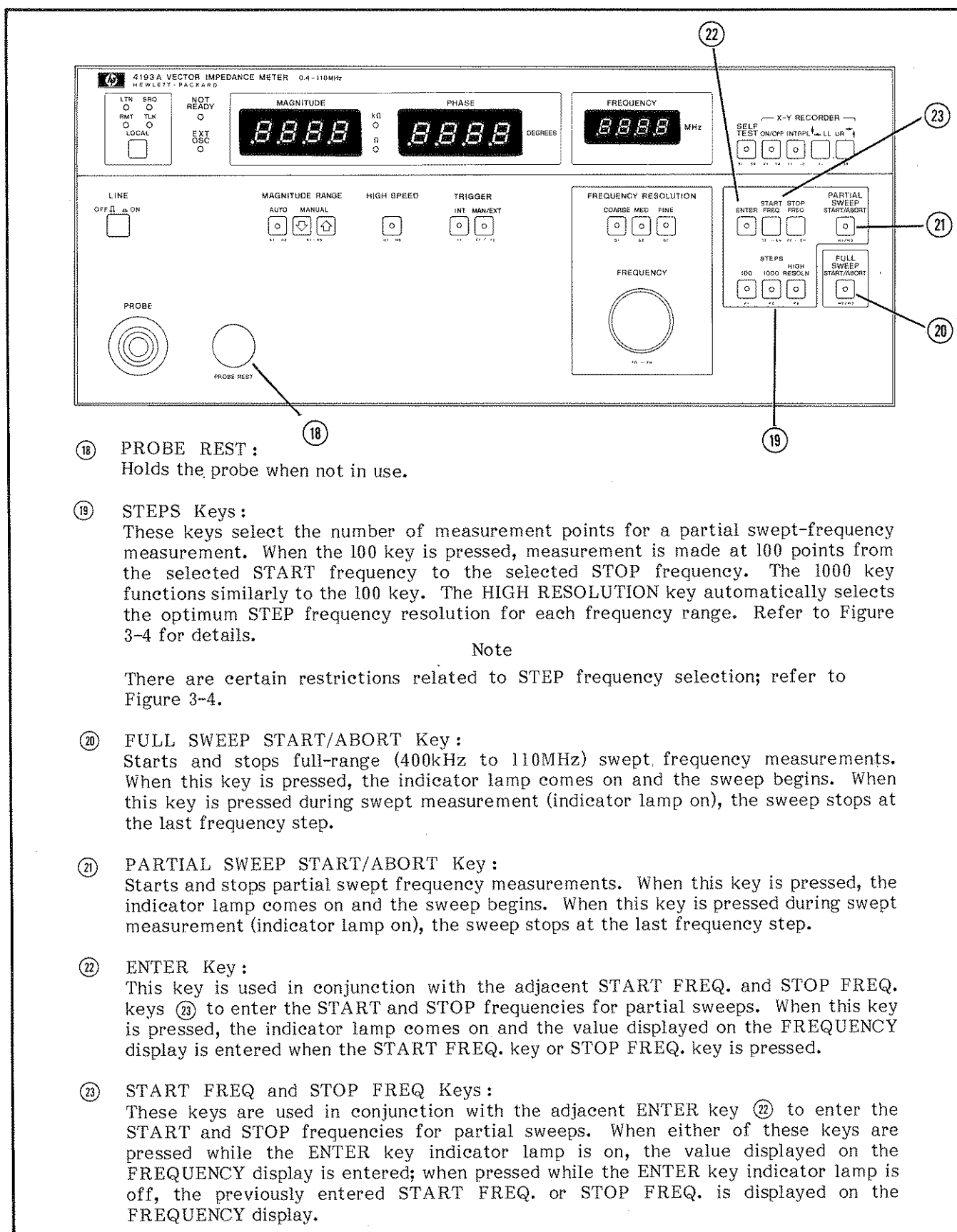

Figure 3-1. Front Panel Features (Sheet 4 of 4).

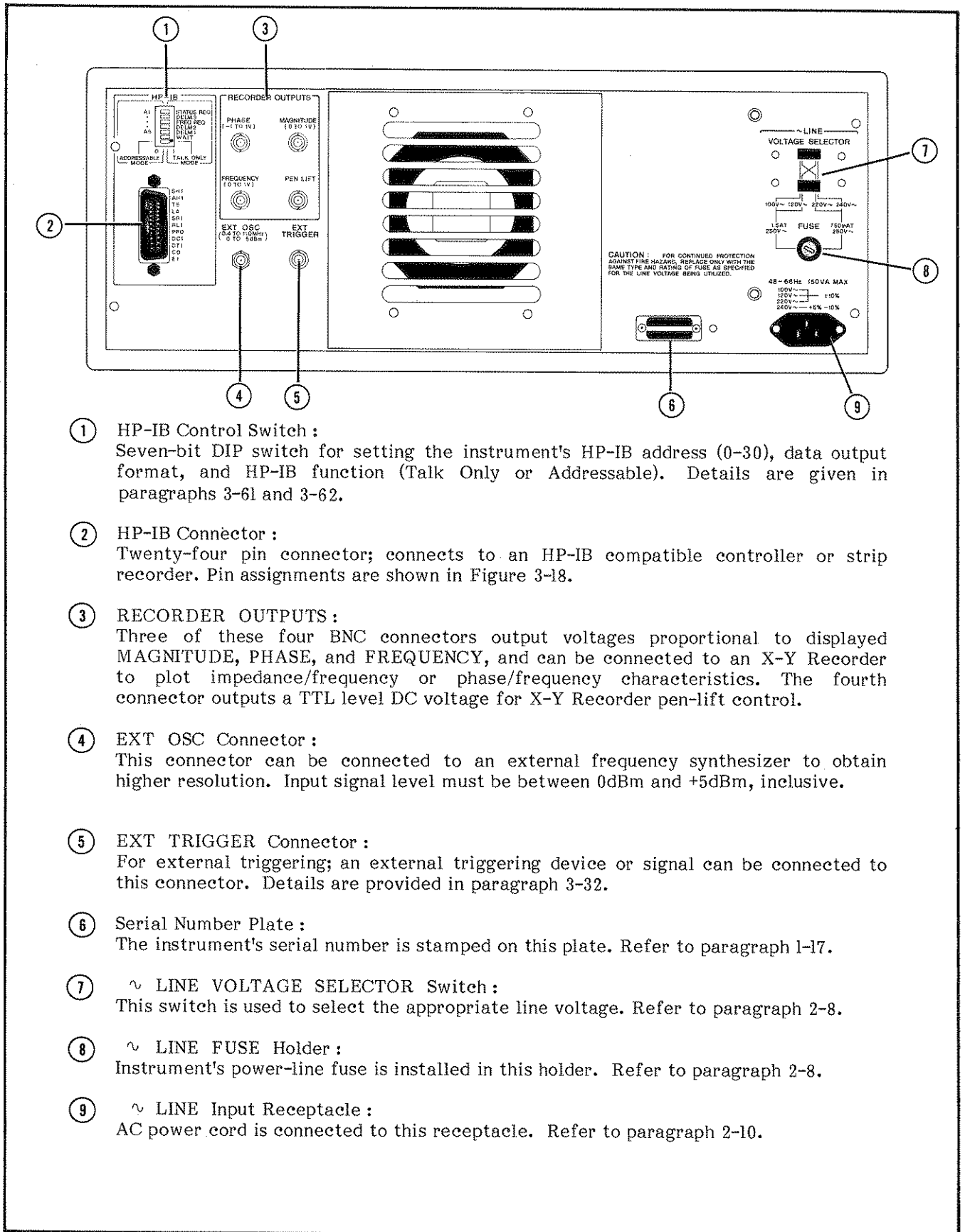

Figure 3-2. Rear Panel Features.

3-9. INITIAL CONTROL SETTINGS

3-10. To facilitate operation, the instrument is automatically set to the following initial control settings each time it is turned on:

Panel Controls :

MAGNITUDE RANGE AUTO
 HIGH SPEED OFF
 TRIGGER INT
 FREQUENCY RESOLUTION .. FINE
 ENTER OFF
 STEPS 100
 PARTIAL SWEEP OFF
 FULL SWEEP OFF
 SELF TEST OFF
 X-Y RECORDER ON/OFF .. OFF
 INTERPOLATION OFF

Test Parameters :

SPOT FREQ. 10MHz
 START FREQ 4MHz
 STOP FREQ..... 110MHz
 RECORDER OUTPUTS..... .0V

3-11. MEASUREMENT RANGE

3-12. As given in Table 3-1, the 4193A has five impedance magnitude ranges. When the MAGNITUDE RANGE is set to AUTO, the 4193A will automatically select the appropriate range. On the other hand, when the MAGNITUDE RANGE is set to MANUAL, the range will be fixed. If the magnitude value for the DUT exceeds the range limit, " **U r** - N" (N is 1, 2, 3, 4, or 5 corresponding to the range number) will be displayed on the MAGNITUDE display.

3-13. TEST SIGNAL LEVEL

3-14. The test signal current through the DUT is constant for the selected measurement range. Refer to Table 3-1. Accordingly, the voltage across the DUT depends on the DUT impedance.

3-15. TEST FREQUENCY

3-16. There are three test frequency ranges, as listed in Table 3-2. Frequency accuracy is 0.01% of the value displayed on the FREQUENCY display. Refer to Figure 3-3 for the frequency setting procedure.

Table 3-1. Measurement Range and Test Signal Level

Magnitude Range	Full-scale Counts	Resolution	Test Signal Level
(1) 10 Ω	19.99 Ω	10m Ω	100 μ Arms
(2) 100 Ω	199.9 Ω	100m Ω	100 μ Arms
(3) 1k Ω	1.999k Ω	1 Ω	100 μ Arms
(4) 10k Ω	19.99k Ω	10 Ω	50 μ Arms
(5) 100k Ω	119. k Ω	1k Ω	10 μ Arms

3-17. SWEPT FREQUENCY MEASUREMENTS

3-18. The 4193A is capable of two types of frequency sweeps : PARTIAL, from the selected START frequency to the selected STOP frequency; and FULL, from 400kHz to 110MHz.

3-19. PARTIAL SWEEP MEASUREMENT

3-20. PARTIAL sweep measurements are used to determine the impedance/phase versus frequency characteristics of a sample over a preselected frequency range. For example, the pass band of a band-pass filter. The test frequency is linearly swept from the selected START frequency to the selected STOP frequency and measurement is made at the number of steps selected by the STEPS keys--100, 1000, or HIGH RES. When HIGH RES is selected, the test frequency is swept (incremented) in accordance with the selected FREQUENCY RESOLUTION key--COARSE, MED, or FINE. The HIGH RES key provides higher step frequency resolution than is possible with the 100 or 1000 STEPS key. For example, if the START frequency is 5MHz, the STOP frequency is 10MHz, and the 1000 STEPS key is selected, measurement is made at 1000 frequency points, which corresponds to a step frequency of 5kHz. But if HIGH RES is used and the FINE key is selected, measurement is made at 5000 frequency points, corresponding to a step frequency of 1kHz. With HIGH RES on, FINE is automatically selected when the PARTIAL SWEEP START/ABORT key is pressed. COARSE or MED can be selected during the sweep. When 100 or 1000 STEPS is selected, the FREQUENCY RESOLUTION keys do not function. The procedure for making a PARTIAL sweep measurement is given in Figure 3-4.

3-21. FULL SWEEP MEASUREMENT

3-22. In FULL sweep measurements the test frequency is logarithmically swept over the 4193A's full frequency range and measurement is made at 43 frequency points. Refer to Figure 3-5 for the frequency of each measurement point. A FULL sweep takes approximately 50 seconds in NORMAL speed mode and 15 seconds in HIGH SPEED mode. The procedure for making a FULL sweep measurement is given in Figure 3-5.

Table 3-2. Test Frequency Range

Test Frequency Range	Resolution
.400 to 9.999MHz	1kHz
10.00 to 99.99MHz	10kHz
100.0 to 110.0MHz	100kHz

SPOT FREQUENCY SETTING PROCEDURE

To manually change the spot frequency, use the procedure given below :

PROCEDURE :

1. Press the FREQUENCY RESOLUTION key labelled COARSE. The indicator lamp in the center of the key will come on.
2. Rotate the FREQUENCY dial (clockwise to increase the frequency, counterclockwise to decrease the frequency) until the two left-most digits of the displayed frequency are at the desired setting.
3. Press the MED key. The indicator lamp in the center of the key will come on.
4. Rotate the FREQUENCY dial until the second digit from the right is at the desired setting.
5. Press the FINE key. The indicator lamp in the center of the key will come on.
6. Rotate the FREQUENCY dial until the right-most digit is at the desired setting.

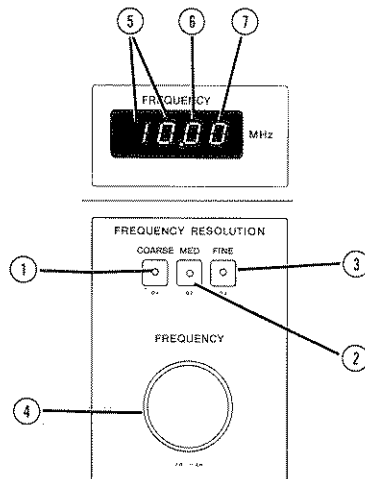

EXAMPLE

Refer to the figure. The desired spot frequency is 55.55MHz.

1. Press the COARSE key ①.
2. Rotate the FREQUENCY dial ④ clockwise until the two left-most digits ⑤ of the displayed frequency are 55.
3. Press the MED key ②.
4. Rotate the FREQUENCY dial ④ clockwise until the second digit from the right ⑥ is 5.
5. Press the FINE key ③.
6. Rotate the FREQUENCY dial ④ clockwise until the right-most digit ⑦ is 5.

Figure 3-3. Spot Frequency Setting Procedure.

PARTIAL SWEEP MEASUREMENT

To make a PARTIAL sweep measurement, use the procedure given below :

PROCEDURE :

1. Connect the probe to the sample.
2. Select the desired START frequency. Refer to Figure 3-3 for the procedure.
3. Press the ENTER key. The indicator lamp in the center of the key will come on.
4. Press the START FREQ. key. The ENTER key indicator lamp will go off.
5. Select the desired STOP frequency. Refer to Figure 3-3 for the procedure.
6. Press the ENTER key. The indicator lamp in the center of the key will come on.
7. Press the STOP FREQ. key. The ENTER key indicator lamp will go off.
8. Press the 100, 1000, or HIGH RES STEPS key to select the number of measurement points. Refer to paragraph 3-19.
9. Press the PARTIAL SWEEP START/ABORT key to start the sweep. The indicator lamp in the center of the key will come on. To stop the sweep, press the PARTIAL SWEEP START/ABORT key. The indicator lamp will go off and the sweep will stop immediately.

Note

If the STOP frequency is lower than the START frequency, E-80 will be displayed on the FREQUENCY display when the PARTIAL SWEEP START/ABORT key is pressed.

Note

If the step frequency is too low for the selected frequency range, the 4193A automatically selects an acceptable step frequency. If, for example, the START frequency is 500kHz, the STOP frequency is 600kHz, and 1000 STEPS is selected, the 4193A automatically selects 100 steps. The 1000 STEPS indicator lamp remains on, however. This automatic adjustment can also occur during a sweep when the frequency is swept over a frequency resolution change point; that is, 10MHz and 100MHz.

Note

Manual PARTIAL sweep can be performed by pressing the MANUAL TRIGGER key.

Figure 3-4. PARTIAL Sweep Measurement.

FULL SWEEP MEASUREMENT

To make a FULL sweep measurement, use the procedure given below :

PROCEDURE :

1. Connect the probe to the sample.
2. Press the FULL SWEEP START/ABORT key. The indicator lamp in the center of the key will come on and the sweep will begin. To stop the sweep, press the FULL SWEEP START/ABORT key. The indicator lamp will go off and the sweep will stop immediately.

The FULL sweep measurement points are listed below :

400kHz, 455kHz, 500kHz, 600kHz, 700kHz, 800kHz, 900kHz, 1MHz, 1.2MHz, 1.4MHz, 1.6MHz, 1.8MHz, 2MHz, 2.333MHz, 2.666MHz, 3MHz, 3.5MHz, 4MHz, 4.5MHz, 5MHz, 6MHz, 7MHz, 8MHz, 9MHz, 10MHz, 12MHz, 14MHz, 16MHz, 18MHz, 20MHz, 23.33MHz, 26.66MHz, 30MHz, 35MHz, 40MHz, 45MHz, 50MHz, 60MHz, 70MHz, 80MHz, 90MHz, 100MHz, 110MHz.

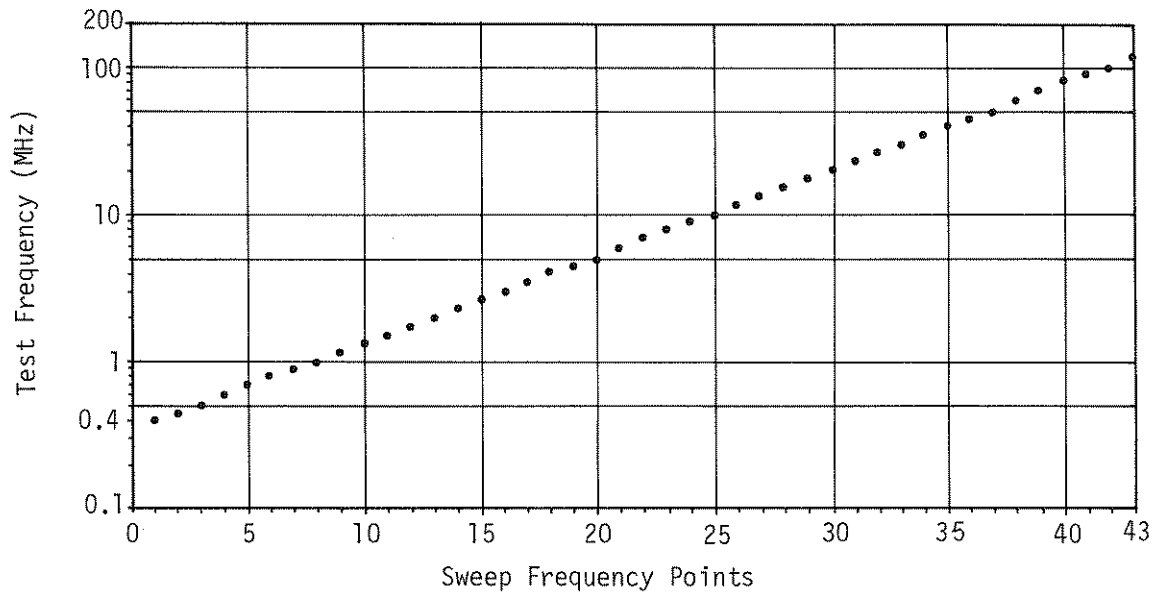

Note

Manual FULL sweep can be performed by pressing the MANUAL TRIGGER key.

Figure 3-5. FULL Sweep Measurement.

3-23. DISPLAYS

3-24. The 4193A has three display sections : MAGNITUDE, PHASE, and FREQUENCY. They are described in paragraphs 3-25 through 3-27, respectively.

3-25. The MAGNITUDE display provides direct readout of measured impedance magnitude with 3 1/2-digit display resolution. The actual number of display digits depends on the measurement range. Maximum number of counts on the 10 Ω , 100 Ω , 1k Ω , and 10k Ω ranges is 1999, and 120 on the 100k Ω range. The least significant digit on the 100k Ω range may be displayed as "  " indicating that the least significant digit is meaningless. Five over-range annunciations are also displayed on this display. Refer to Table 3-4.

3-26. The PHASE display provides direct readout of measured phase angle with 3 1/2-digit display resolution. Maximum number of counts is 1800. When measurement is made on the 100k Ω range, the least significant digit of measured phase values may be displayed as "  " indicating that the least significant digit is meaningless. Also, when an over-range occurs on the MAGNITUDE display or when the measured magnitude is less than 20 counts, " - - - - " will be displayed on the PHASE display.

3-27. The FREQUENCY display provides direct readout of SPOT, START, and STOP frequencies with 4-digit display resolution. Error-codes related to mis-operation and instrument failure are also displayed here. Refer to paragraph 3-28.

3-28. Error-Code and Over-range Annunciations

3-29. Error-codes related to mis-operation and over-range annunciations are listed, along with a brief description, in Tables 3-3 and 3-4, respectively. Error codes related to SELF TEST and instrument failure are listed in Table 3-5. If an error listed in Table 3-5 should occur, contact the nearest Hewlett-Packard Sales/Service Office.

3-30. INITIAL DISPLAY TEST

3-31. All display segments and indicator lamps are lit for approximately one second each time the instrument is turned on. If a display segment or indicator lamp fails to light or does not light properly, it must be replaced.

Table 3-3. Operational Error-codes





Error-code	Meaning
 E-51	Lower-left key () or upper-right key () was pressed or selected via the HP-IB with the X-Y RECORDER function set to ON and TRIGGER set to INT.
 E-61	The HP-IB Address Control Switch is set to address 31 (11111). Only addresses 0 (00000) through 30 (11110) are allowed.
 E-80	STOP FREQ. is lower than the START FREQ. in PARTIAL SWEEP operation.

Table 3-4. Annunciations

MAGNITUDE Display	PHASE Display	Meaning	Treatment
0r 1	----	Measured impedance magnitude value exceeds the upper limit of 10 Ω range (Range 1).	Change the MAGNITUDE range to range 2.
0r 2	----	Measured impedance magnitude value exceeds the upper limit of 100 Ω range (Range 2).	Change the MAGNITUDE range to range 3.
0r 3	----	Measured impedance magnitude value exceeds the upper limit of 1k Ω range (Range 3).	Change the MAGNITUDE range to range 4.
0r 4	----	Measured impedance magnitude value exceeds the upper limit of 10k Ω range (Range 4).	Change the MAGNITUDE range to range 5.
0r 5	----	Measured impedance magnitude value exceeds the upper limit of 100k Ω range (Range 5).	

Table 3-5. SELF TEST Error-codes

Code	Description
E-01	A17U1 (RAM) is faulty.
E-02	A17U2 (RAM) is faulty.
E-03	A17U3 (ROM) is faulty.
E-04	A17U4 (ROM) is faulty.
E-05	A17U5 (ROM) is faulty.
E-06	A17U6 (ROM) is faulty.
E-07	A17U7 (ROM) is faulty.
E-30	A13 Detection board is not functioning properly.
E-40	A14 ADC board is not functioning properly.
E-41	A17 Control Logic board is not functioning properly.
E-60	A16 HP-IB board is not functioning properly.
E-70	A17 Control Logic board is not functioning properly.
E-71	A17 Control Logic board is not functioning properly.

3-32. EXTERNAL TRIGGERING

3-33. The 4193A can be externally triggered by connecting a trigger device to the EXT TRIGGER connector on the rear-panel. The instrument is triggered (measurement is made) each time a low-going TTL level pulse is applied to this connector or each time the center conductor is shorted and opened to ground. The instrument must be set to the MAN/EXT trigger mode for external trigger operation.

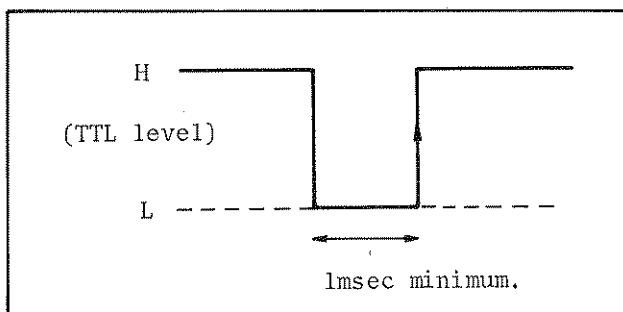

Figure 3-6. External Trigger Pulse.

3-34. MEASUREMENT TIME

3-35. Measurement time for a given DUT is approximately 1s in normal speed mode and 150ms in high speed mode, with the X-Y RECORDER off and the test frequency constant. Additional time is required when the test frequency is changed, the DUT is changed, or the measurement range is changed. Refer to Table 3-6 for typical values.

Table 3-6. Additional Measurement Times

	Typical Time	Remarks
Freq. Settling Time	100ms (5ms to 400ms)	Changing frequency.
Wait Time	200ms	Changing DUT.
Ranging Time	1.2s	Ranging up or down one range.

3-36. USE OF FURNISHED PROBE ADAPTERS

3-37. Four probe adapters are furnished to facilitate connection to a wide range of DUT types. Each probe adapter is listed in Table 3-7.

Table 3-7. Furnished Probe Adapters

Adapter	HP Part No.
BNC Adapter	04193-61152
Component Adapter	04193-61153
Ground Adapter	04193-61154
Probe Socket	04193-21008

3-38. The BNC Adapter is provided for input and output impedance measurements on circuits equipped with BNC female connectors. The Component Mounting Adapter is used for measurements on discrete axial- or radial-lead component. The Probe Socket is for user-fabricated test fixtures, as shown in Figure 3-7. It is available for supporting the probe, which is attached to the user-built fixture and is connected to ground.

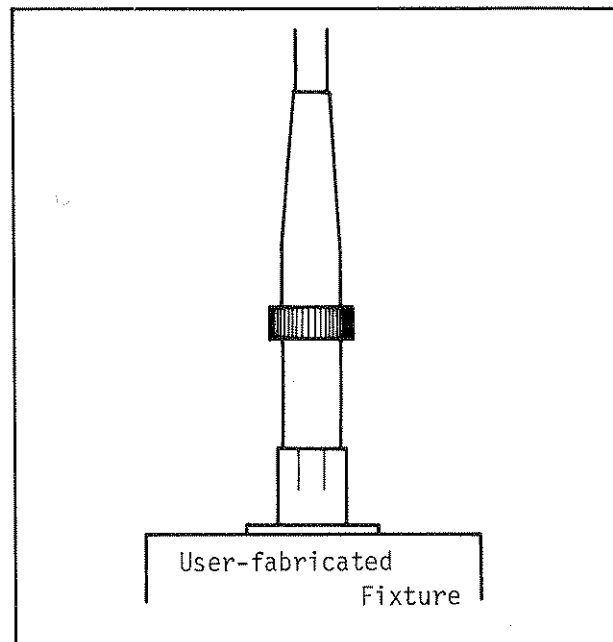

Figure 3-7. Probe Socket Usage.

3-39. PROBE

3-40. The instrument is adjusted to meet the specifications listed in Table 1-1, with the furnished probe connected. If the probe (HP P/N 04193-61151) is replaced or repaired, the adjustments described in Section VIII must be performed. For information on probe replacement or repair, contact the nearest Hewlett-Packard Sales/Service Office.

CAUTION

DO NOT CONNECT THE PROBE TO A COMPONENT OR CIRCUIT THAT HAS A DC BIAS EXCEEDING 50V OR AN AC VOLTAGE EXCEEDING 5V RMS. TO DO SO MAY DAMAGE THE INSTRUMENT.

Note

To ensure measurement accuracy, make sure that the coupling nuts, probe barrel, and probe tip are firmly tightened.

SECTION III

3-41. Probe and Test Fixture Residuals

3-42. The equivalent circuit of the 4193A's measurement port is shown in Figure 3-8. All measured values displayed on the MAGNITUDE and PHASE displays include the residuals of the probe and the test fixture. Typical values of each residual are listed in Table 3-8.

3-43. The conductive component of the open-circuit admittance of the equivalent circuit shown in Figure 3-8 is sufficiently larger than the susceptive component, c, at the frequencies below 110MHz to be negligible.

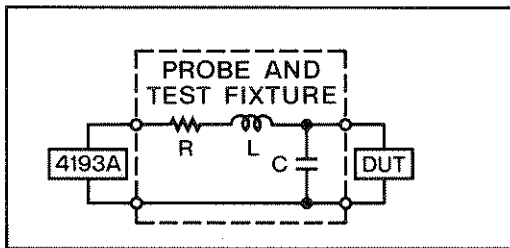

Figure 3-8. Equivalent Circuit.

3-44. Residuals compensation can be made using the following procedure :

- (1). Connect nothing to the test fixture (or probe) and note the value displayed as Z_o .
- (2) Short the test fixture (or probe) and note the value displayed as Z_s .
- (3) Calculate the DUT's actual impedance using the equation given in Figure 3-9.

Table 3-8. Typical Residuals at 100MHz

PROBE AND TEST FIXTURE	R (Ω)	L (nH)	C (pF)
PROBE + 16099A	0.5	10	2.4
PROBE + 16099A + 16092A	0.5	11	3.5
PROBE + 16099A + 16093A	0.5	12	4.2
PROBE + 16099A + 16093B	0.5	12	7.9

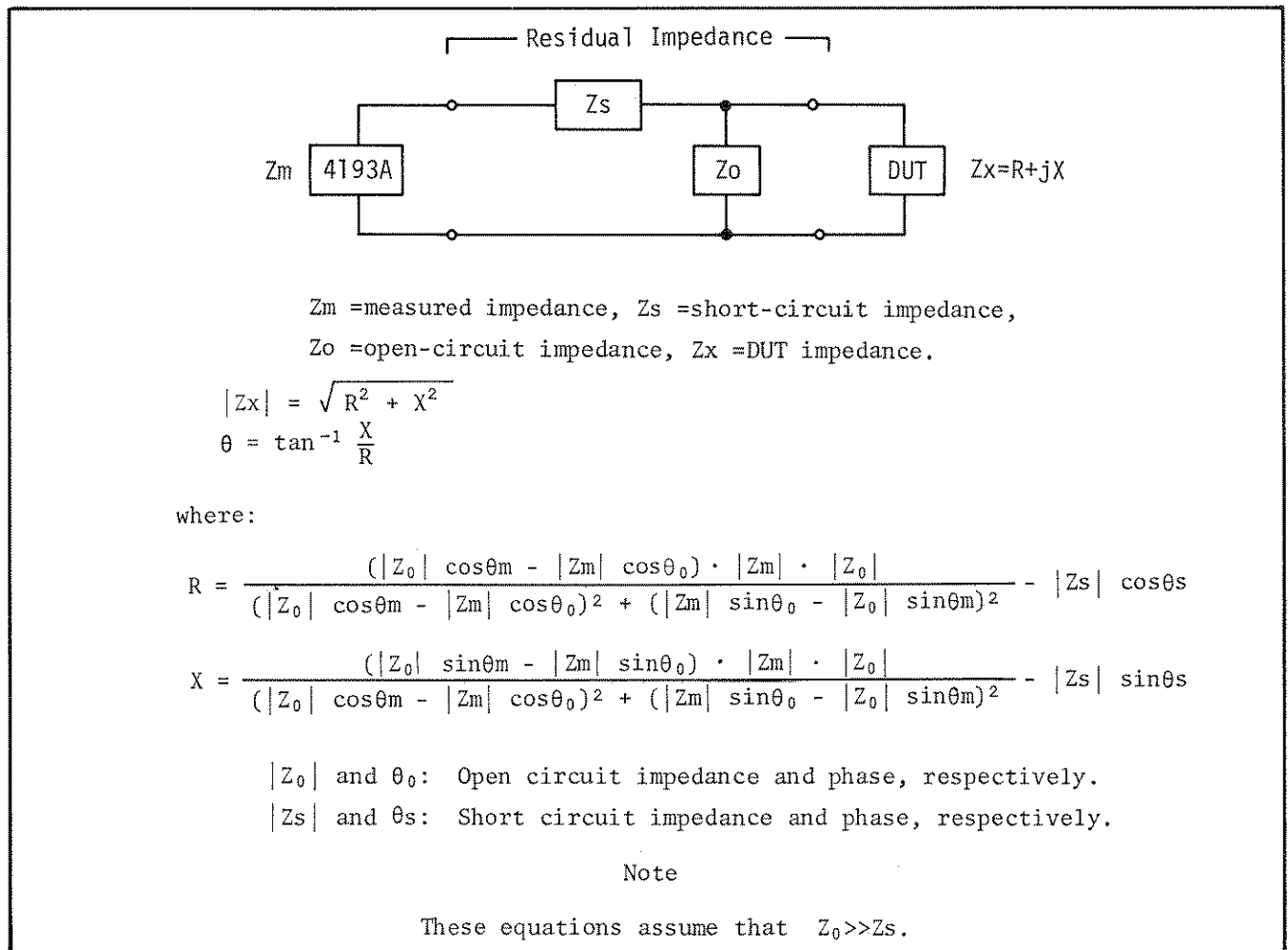

Figure 3-9. Residuals Compensation.

SECTION III

3-45. EXTERNAL OSCILLATOR

3-46. An external signal source (output impedance: $50\Omega \pm 10\%$) can be connected to the EXT. OSC. connector on the rear-panel to obtain higher test signal resolution than is possible with the 4193A's internal signal source. This feature makes it possible to measure high-Q devices such as crystals. A maximum test signal resolution of 100Hz is possible when an external signal source is used. The external oscillator controls frequency only; the 4193A controls the level of the test signal applied to the DUT. The level of the external signal must be from 0 to 5dB. When the external signal source is connected to the 4193A, the EXT. OSC. indicator lamp on the front-panel comes on automatically. The difference between the 4193A's test signal frequency setting and that of the external signal source's should not exceed 10MHz. For best results the 4193A's test signal frequency should be set as close as possible to that of the external signal source.

3-47. X-Y RECORDER OUTPUT

3-48. The 4193A is equipped with three analog output connectors on the rear-panel (MAGNITUDE, PHASE, FREQUENCY) which output DC voltages proportional to the displayed magnitude, phase, and frequency values. These connectors can be connected to an X-Y Recorder to plot the impedance/frequency or phase/frequency characteristics of the sample impedance. A PEN LIFT connector is also provided for use with X-Y Recorders equipped with remote pen-lift control.

3-49. ANALOG MAGNITUDE OUTPUT

3-50. DC voltage output from the MAGNITUDE connector is proportional to the number of counts displayed on the MAGNITUDE display. Output voltage is calculated as :

$$V_M = \frac{C_M}{2000} \text{ (Volts)}$$

where V_M is the analog output voltage and C_M is the number of counts displayed on the MAGNITUDE display. When C_M is 2000 counts (full-scale), for example, V_M is +1 volt. MAGNITUDE output voltage range is 0 to 1 volt.

Note

If the sample's impedance is higher than the full-scale limit of the selected range, $\frac{Z}{N}$ (N represents the magnitude range : 1 = 10Ω range, 2 = 100Ω range, 3 = $1k\Omega$ range, 4 = $10k\Omega$ range, 5 =

$100k\Omega$ range) will be displayed on the MAGNITUDE display and the analog output voltage will be 1 volt.

3-51. ANALOG PHASE OUTPUT

3-52. DC voltage output from the PHASE connector is proportional to the number of counts displayed on the PHASE display. Output voltage is calculated as :

$$V_p = \frac{C_p}{1800} \text{ (Volts)}$$

where V_p is the analog output voltage and C_p is the number of counts (with sign) displayed on the PHASE display. When C_p is 1800 counts (full-scale positive), for example, V_p is +1 volt; conversely, when C_p is -1800 counts (full-scale negative), V_p is -1 volt. PHASE output voltage range is 0 to ± 1 volt.

Note

The above equation is valid even when "----" is displayed on the PHASE display. The last valid phase value is used for C_p in this case.

3-53. ANALOG FREQUENCY OUTPUT

3-54. DC voltage output from the FREQUENCY connector is proportional to the displayed frequency, but is different for each sweep mode. Output voltage is calculated as :

For PARTIAL SWEEP :

$$V_F = \frac{f_{SPOT} - f_{START}}{f_{STOP} - f_{START}} \text{ (Volts)}$$

For FULL SWEEP :

$$V_F = \frac{\log(f_{SPOT}/f_{START})}{\log(f_{STOP}/f_{START})} \text{ (Volts)}$$

where V_F is the analog output voltage and f_{SPOT} , f_{START} , and f_{STOP} are, respectively, the test frequency displayed the FREQUENCY display, the sweep START frequency, and the sweep STOP frequency. All frequencies are in MHz.

Note

When neither sweep mode is selected (SPOT Measurement), the output voltage is calculated using the PARTIAL SWEEP equation.

IN-CIRCUIT IMPEDANCE MEASUREMENT

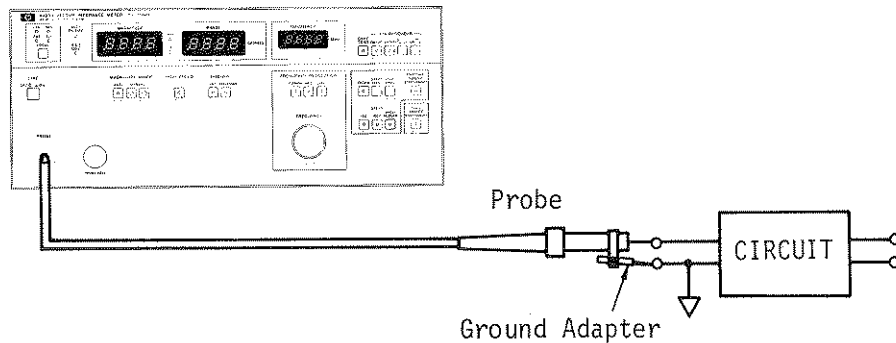

SETUP :

Attach the furnished slide-on ground adapter (HP Part No. : 04193-61154) to the probe barrel, as shown in the figure.

PROCEDURE :

1. Turn on the instrument and verify that it passes the initial display test and that "PASS" is displayed on the FREQUENCY display at the completion of the SELF TEST.
2. Set the desired test frequency by rotating the Frequency Control Dial, as described in Figure 3-3.
3. Connect the probe center pin and the ground pin to the sample circuit terminals as shown above. If the ground pin is too short to reach the sample circuit's ground terminal, use the furnished ground lead (HP Part No. : 04193-61629), as shown below :

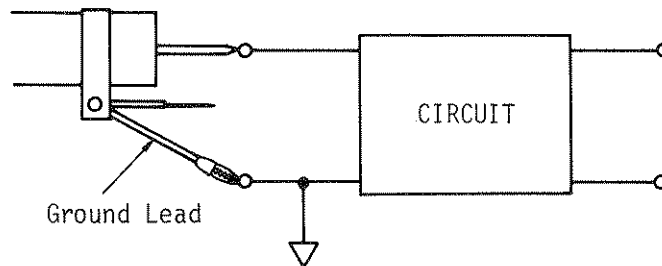

CAUTION

DO NOT CONNECT THE PROBE TO A CIRCUIT THAT HAS A DC BIAS EXCEEDING 50V OR AN AC VOLTAGE EXCEEDING 5V RMS. TO DO SO MAY DAMAGE THE INSTRUMENT.

Note

The circuit terminal distance should be as short as possible.

Note

The residual impedance of the ground adapter is less than that of the ground lead.

Note

The probe pin (HP Part No. : 16095-60012) and the ground pin (HP Part No. : 0360-2066) are replaceable.

Figure 3-10. In-circuit Impedance Measurement Procedure.

GENERAL COMPONENT MEASUREMENT

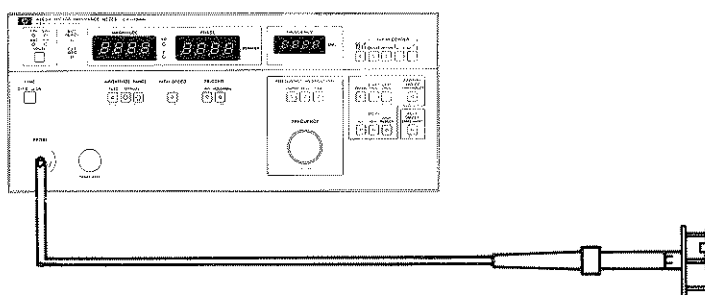

SETUP :

Attach the furnished component adapter (HP Part No. : 04193-61153) to the end of the probe, as shown in the figure.

PROCEDURE :

1. Turn on the instrument and verify that it passes the initial display test and that "PASS" is displayed on the FREQUENCY display at the completion of the SELF TEST.
2. Set the desired test frequency by rotating the Frequency Control Dial, as described in Figure 3-3.
3. Connect the DUT between the center terminal and one of the outer terminals of the component adapter, as shown in the figure.
4. Read the measured impedance and phase displayed on the MAGNITUDE and PHASE displays, respectively.

CAUTION

DO NOT CONNECT THE PROBE TO A COMPONENT THAT HAS A DC BIAS EXCEEDING 50V OR AN AC VOLTAGE EXCEEDING 5V RMS. TO DO SO MAY DAMAGE THE INSTRUMENT.

Note

The component adapter dimensions are shown below. The terminals (HP Part No. : 04193-60151) are replaceable.

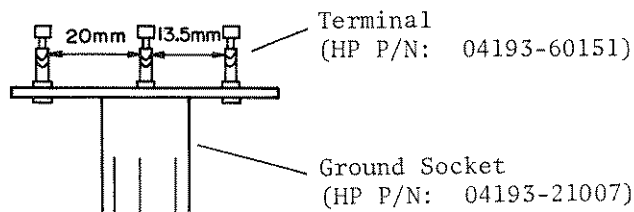

Note

For measurement of components that cannot be connected to the component adapter, the 16092A/16093A/16093B test fixtures are available. Refer to Table 1-4.

Figure 3-11. General Component Measurement Procedure.

EXTERNAL OSCILLATOR USAGE

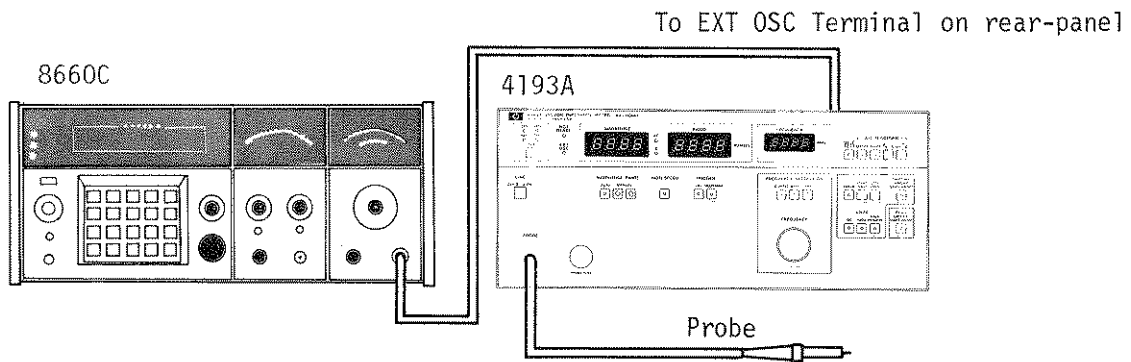

EQUIPMENT :

- Synthesized Signal Generator Generator with 86633B and 86601B
- TYPE N (male)-BNC (female) Adapter HP P/N :1250-1535
- BNC (male)-BNC (male) Cable HP 10503A

PROCEDURE :

1. Turn off both instruments.
2. Connect the synthesizer's RF section to the 4193A's EXT. OSC. connector, as shown in the figure.
3. Set the synthesizer's output level to 0dBm.

Note

DO NOT allow the synthesizer's output level to exceed +5dBm. To do so may damage the 4193A.

4. Turn on both instruments.
5. Confirm that the EXT. OSC. indicator lamp on the 4193A's front-panel comes on after completion of the initial SELF TEST.
6. Connect the probe to the device or circuit under test and set the instruments' controls as appropriate for the measurement. For best results, set the 4193A's test frequency as close as possible to the synthesizer's frequency.

Note

The maximum allowable difference between the 4193A's test frequency setting and the external synthesizer's setting is 10MHz.

Note

Maximum obtainable frequency resolution for measurements using an external frequency synthesizer is approximately 100Hz over the 4193A's full frequency range, 400kHz to 110MHz.

Figure 3-12. External Oscillator Usage Procedure.

X-Y RECORDER SETUP

EQUIPMENT:

X-Y RECORDER HP 7046A
 BNC (male)-Dual Banana Plug Cable HP11001A (4 ea.)

PROCEDURE

1. Turn off the 4193A's X-Y RECORDER function--X-Y RECORDER ON/OFF indicator lamp should be off.
2. Locate the 4193A's X-Y RECORDER OUTPUTS on the rear-panel (see Figure 3-2) and connect FREQUENCY to the recorder's X-axis, MAGNITUDE to the Y1-axis, PHASE to the Y2-axis, and PEN LIFT to the recorder's REMOTE PEN jack (rear-panel).
3. Place the chart paper on the recording platen and set the CHART switch to the HOLD Position. PEN switch should be set to LIFT.
4. Press the \downarrow LL key on the 4193A and, referring to Figure A, position pen 1 at the black dot (•) and pen 2 at the cross (x).
5. Press the UR \rightarrow key on the 4193A and, referring to Figure A again, position both pens at the circle (o).

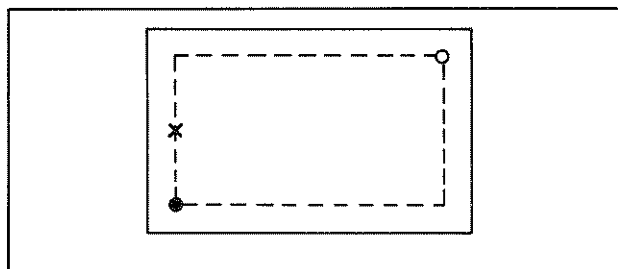

Figure A. Plot Area of RECORDER OUTPUTS.

Note

On some X-Y Recorders, zero and full-scale adjustments may be interactive. Repeat steps 4 and 5, if necessary.

6. Connect the probe to the device or circuit under test and set the 4193A's controls as appropriate for the measurement.
7. Perform one swept measurement with the X-Y RECORDER function set to OFF and note the measurement range at which the DUT's impedance is highest.
8. Using the MANUAL MEASUREMENT RANGE keys, \downarrow and \uparrow , set the 4193A's measurement range to the range noted in step 7.
9. Press the X-Y RECORDER ON/OFF key--indicator lamp will come on--and press the PARTIAL SWEEP or FULL SWEEP key to start the plot.

Note

The above procedure is for 2-pen recorders equipped with remote pen-lift control. For single-pen recorders and recorders not equipped with remote pen-lift control, the above procedure must be modified slightly.

Figure 3-13. X-Y Recorder Usage Procedure.

SECTION III

3-55. HP-IB COMPATIBILITY

3-56. The 4193A can be remotely controlled via the HP-IB, a carefully defined instrument interface which simplifies integration of instruments and a calculator or computer into a system.

Note

HP-IB is Hewlett-Packard's implementation of IEEE Std. 488, Standard Digital Interface for Programmable Instrumentation.

3-57. HP-IB INTERFACE CAPABILITIES

3-58. The 4193A has eight HP-IB interface functions, as listed in Table 3-9.

3-59. CONNECTION TO HP-IB

3-60. The 4193A can be connected into an HP-IB bus configuration with or without a controller (i.e., with or without an HP calculator). In an HP-IB system without a controller, the instrument functions as a "talk only" device.

3-61. HP-IB CONTROL SWITCH

3-62. The HP-IB Control Switch, located on the rear panel, has seven bit switches as shown in Figure 3-14. Each bit switch has two settings : logical 0 (left position) and logical 1 (right position). Bit switch 7 determines whether the instrument will be addressable by the controller

in a multi-device system, or will function as a "talk only" device to output measurement data and/or instructions to an external "listener," e.g., printer or plotter.

When bit switch 7 is set to 0, the instrument is in ADDRESSABLE mode and bit switches 1 through 5 determine the instrument address; when this switch is set to 1, the instrument is in TALK ONLY mode.

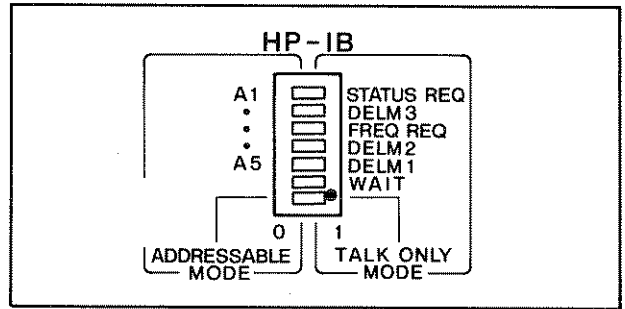

Figure 3-14. HP-IB Control Switch.

3-63. ADDRESSABLE MODE

3-64. When bit switch 7 is set to ADDRESSABLE (i.e., set to 0), bit switches 1 through 5 represent the HP-IB address of the instrument, in binary. These switches are set to 10001 (decimal 17) when the instrument leaves the factory but can be set to any desired address between 0 and 30. Bit switch 6 has no meaning in this mode. The HP-IB Control Switch, set to the ADDRESSABLE mode and with the factory address setting, is shown in Figure 3-15.

Table 3-9. HP-IB Interface Capabilities

Code	Interface Function* (HP-IB Capabilities)
SHI**	Source Handshake
AH1	Acceptor Handshake
T5	Talker (basic talker, serial poll, talk only mode, unaddress to talk if addressed to listen)
L4	Listener (basic listener, unaddress to listen if addressed to talk)
SR1	Service Request
RL1	Remote/Local (with local lockout)
DC1	Device Clear
DT1	Device Trigger

* Interface functions provide the means for a device to receive, process, and transmit messages over the bus.

** The suffix number of the interface code indicates the limitation of the function capability as defined in Appendix C of IEEE STD. 488.

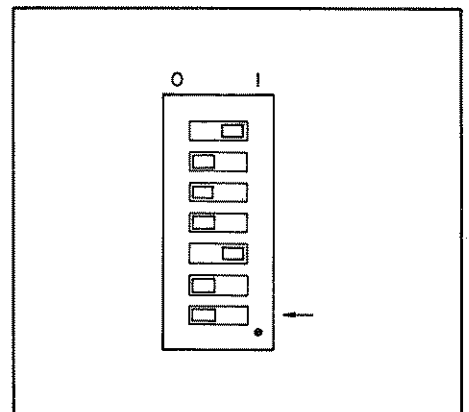

Figure 3-15. ADDRESSABLE Mode.

Note

When the instrument is turned on, the address is displayed on FREQUENCY display after the SELF TEST. If the address switches are set to 10001, the display is as shown below :

FREQUENCY



3-65. TALK ONLY MODE

3-66. When bit switch 7 is set to TALK ONLY (i.e., set to 1) as shown in Figure 3-16, the other bit switches, 1 through 6, function as described in Table 3-10.

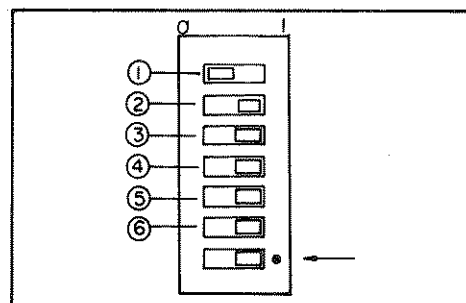

Figure 3-16. TALK ONLY Mode.

Table 3-10. Functions of Bit Switches ① through ⑥

Bit Switch	Name	Function When Set to 1	Function When Set to 0
⑥	WAIT	After a measurement, the 4193A waits until all measurement data has been received by the listener before proceeding to the next measurement, even in internal trigger mode.	After a measurement, the 4193A proceeds to the next measurement regardless of whether the listener has received all the measurement data or not.
⑤	DELM1	Selects (CR) (LF) as the Delimiter for the magnitude field.* When a printer is connected to the 4193A, this delimiter causes the printer to perform a carriage return and a line feed.	Selects the comma "," as the delimiter for the magnitude field.* The printer does not perform a carriage return or line feed.
④	DELM2	Selects (CR) (LF) as the delimiter for the phase field.* This delimiter causes the printer to perform a carriage return and a line feed.	Selects the comma "," as the delimiter for the phase field.* The printer does not perform a carriage return or line feed.
③	FREQ REQ	Specifies that frequency data be output along with magnitude and phase data.	Frequency data is not output.
②	DELM3	Selects (CR) (LF) as the delimiter for the frequency field.* This delimiter causes the printer to perform a carriage return and a line feed.	Selects the comma "," as the delimiter for the frequency field.* The printer does not perform a carriage return or line feed.
①	STATUS REQ	Specifies that status data be output along with magnitude and phase data.	Status data is not output.

* Refer to para. 3-71, Data Output.

SECTION III

3-67. HP-IB STATUS INDICATORS

3-68. The HP-IB Status Indicators are four LED lamps located on the front panel. When lit, these lamps show the existing status of the 4193A in the HP-IB system as follows :

SRQ: SRQ signal from the 4193A to the controller is on the HP-IB line. Refer to paragraph 3-77.

LISTEN: The 4193A is set to listener.

TALK: The 4193A is set to talker.

REMOTE: The 4193A is remotely controlled.

3-69. LOCAL KEY

3-70. The LOCAL key releases the 4193A from HP-IB remote control and allows measurement conditions to be set from the front panel. The REMOTE lamp will go off when this key is pressed. LOCAL control is not available when the 4193A is set to "local lockout" status by the controller.

3-71. DATA OUTPUT

3-72. Measurement and status data are output to external devices in bit parallel, byte serial format via the eight DIO signal lines of the HP-IB. These data consist of impedance magnitude and phase data, test frequency data, and key status data. Magnitude and phase data are always output, but output of test frequency data and key status data depends on the program (ADDRESSABLE), or the setting of the HP-IB Control Switch on the rear panel, refer to Table 3-10. All characters are coded in accordance with ASCII coding conventions.

[1] Impedance Magnitude Data Field

This field contains READY/NOT READY information and the value of the measured impedance.

$$\frac{Yx^*, Sx, ZMxxxxx}{(1) (2) (3)} \frac{Ex}{(4) (5)}$$

* x represents single digit, variable numeric data.

(1) Status of measurement : Y0 = NOT READY, Y1 = READY.

(2) Status of magnitude data : S0 = less than 18 counts, S1 = less than 180 counts, S2 = 180 to 2000 counts, S3 = over range, S4 = Er - 40 or Er - 41, S5 = Er - 30, S6 = Er - 30 and Er - 40.

(3) Magnitude display counts.

(4) Unit : E0 = Ω, E3 = kΩ

(5) Delimiter: comma in ADDRESSABLE mode. In TALK ONLY mode, (CR) (LF) or a comma depending on the setting of bit switch 5 on the HP-IB Control Switch. Refer to Table 3-10.

[2] Impedance Phase Data Field

This field contains the phase of the measured impedance.

$$\frac{ZPs * xxx.x}{(1) (2)}$$

* s represents the sign (+ or -).

(1) Sign and magnitude with decimal point of the measured phase.

(2) Delimeter : See [1].

[3] Frequency Field

This field contains test frequency information.

$$\frac{Wx, Bx, FRxxxxx}{(1) (2) (3)} \frac{Ex, Px, Qx}{(4) (5) (6) (7)}$$

(1) Sweep mode : W1 = partial sweep, W2 = full sweep, W3 = last frequency in sweep measurement, W4 = spot measurement.

(2) Oscillator : B0 = Internal oscillator, B1 = External oscillator.

(3) Frequency display counts.

(4) Unit : E6 = MHz

(5) Partial sweep step : P1 = 100, P2 = 1000, P3 = HIGH RESOLN.

- (6) Frequency resolution : Q1 = COARSE, Q2 = MED, Q3 = FINE.
- (7) Delimiter : See [1].

[4] Status Field

This field contains key status data (front panel control settings).

$\frac{Ax, Rx, Hx, Tx, Xx, Ix, Gx, Dx}{(1) (2) (3) (4) (5) (6) (7) (8)}$

- (1) Magnitude range mode : A0 = HOLD, A1 = AUTO.
- (2) Magnitude range : R1 = 10 Ω , R2 = 100 Ω , R3 = 1k Ω , R4 = 10k Ω , R5 = 100k Ω .
- (3) High speed mode : H0 = OFF, H1 = ON.
- (4) Trigger mode : T1 = INT, T2 = HOLD.
- (5) X-Y Recorder ON/OFF : X0 = OFF, X1 = ON.
- (6) Interpolation : I0 = OFF, I1 = ON.
- (7) External trigger : G0 = Disable, G1 = Enable.
- (8) Data ready : D0 = SRQ OFF, D1 = SRQ ON.

3-73. OUTPUT DATA FORMAT

3-74. There are four output data formats available on the 4193A, as listed in the table below. The format is determined by the HP-IB program (ADDRESSABLE mode). For TALK ONLY mode, see Table 3-10.

3-75. Programming Guide for the 4193A

3-76. Sample programs that can be run on the Model 9825A or HP-85 Desktop Computer are given in Figures 3-19 and 3-20.

Note

Specific information on HP-IB programming with the 9825A and HP-85 can be found in the programming manual of each computer.

Following equipment are required to run the sample programs :

- (1) 4193A Vector Impedance Meter
- (2) 98034A/B HP-IB Interface Card
- (3) 9825A Desktop Computer with 98210A String-Advanced Programming ROM and 98213A General I/O-Extended I/O ROM, or 9825B/T.

or

- (2) 82937A HP-IB INTERFACE
- (3) HP-85 Personal Computer with 00085-15003 INPUT/OUTPUT ROM.

3-77. SERVICE REQUEST STATUS BYTE

3-78. The 4193A outputs an RQS (Request Service) signal whenever it is set to one of the six possible service request states. Figure 3-17 shows the contents of the Status Byte.

Bit 7 (RQS) indicates whether or not a service request exists. Bit 8 is always zero (0). Bits 1 through 6 identify the type of service request. Following are the service request states of the 4193A.

Table 3-11. Output Data Format

Format	Fields Output			
	Magnitude	Phase	Freq.	Status
FMT1	Yes	Yes	No	No
FMT2	Yes	Yes	Yes	No
FMT3	Yes	Yes	No	Yes
FMT4	Yes	Yes	Yes	Yes

SECTION III

(1) Bit 6: Set when no syntax error but program is inoperative as follows:

(1) During PARTIAL/FULL SWEEP:

Changing SPOT FREQ. (FR x EN)

Executing LL, UR when X-Y RECORDER OUTPUT is ON

Executing SELF TEST (SI)

(2) During PARTIAL SWEEP:

Changing STEPS (P1, P2, P3)

(3) When X-Y RECORDER OUTPUT is OFF:

Executing INTRPL (I0, I1)

(4) When X-Y RECORDER OUTPUT is ON and TRIGGER is INT:

Executing Lower Left (LL) or Upper Right (UR)

(2) Bit 5: Indicates the result of the SELF TEST; 0 = FAIL, 1 = PASS.

(3) Bit 4: Set when the 4193A is externally triggered before data has been completely output in REMOTE state.

(4) Bit 3: Set when SELF TEST is completed.

(5) Bit 2: Set when the remote program contains a syntax error.

(6) Bit 1: Set when measured data is valid, independent of "D0" or "D1" setting.

3-79. PARAMETER SETTING

3-80. SPOT FREQUENCY and PARTIAL SWEEP START and STOP frequencies are set via remote programming, as follows:

SPOT FREQUENCY: $\frac{FR}{(1)} \times \frac{EN}{(2)(3)}$

PARTIAL SWEEP

START FREQUENCY: $\frac{TF}{(1)} \times \frac{EN}{(2)(3)}$

STOP FREQUENCY: $\frac{PF}{(1)} \times \frac{EN}{(2)(3)}$

(1) Parameter program code

(2) Four digit (max.) number between 0.400 and 110.0; the unit is MHz.

(3) Parameter terminator

8 MSB	7	6	5	4	3	2	1 LSB
	SRQ	Prog. logic error	Self test result	Trig. too fast	Self test end	Syntax error	Data ready

Figure 3-17. Status Byte.

Table 3-12. REMOTE PROGRAM CODE

FUNCTION	CONTROL	CODE	DESCRIPTION
FREQUENCY RESOLUTION	COARSE MED FINE	Q1 Q2 Q3*	
AUTO MAGNITUDE RANGE	OFF ON	A0 A1*	
MAGNITUDE RANGE	10Ω range 100Ω range 1kΩ range 10kΩ range 100kΩ range	R1 R2 R3 R4 R5	00.00 - 19.99Ω 000.0 - 199.9Ω 0.000 - 1.999kΩ 00.00 - 19.99kΩ 000. - 120. kΩ
HIGH SPEED MODE	OFF ON	H0* H1	>1 measurement/second ≥3 - 10 measurement/second
SWEEP STEP	100 steps 1000 steps HIGH RESOLUTION	P1* P2 P3	Sweep the least significant digit by 1 count.
AUTO SWEEP	PARTIAL SWEEP START FULL SWEEP START SWEEP ABORT	W1 W2 W3	For both PARTIAL and FULL sweep.
TRIGGER	INTERNAL MAN/EXT	T1* T2	Specifies MAN/EXT trigger mode.
EXECUTE		EX	Triggers the 4193A.
EXTERNAL TRIGGER	OFF ON	G0 G1*	Disables external trigger. Enables external trigger.
RECORDER OUTPUT	OFF ON LOWER LEFT UPPER RIGHT	X0* X1 LL UR	
INTERPOLATION	OFF ON	I0* I1	
SELF TEST	OFF ON	S0* S1	
DATA READY SRQ	OFF ON	D0* D1	Outputs SRQ when data is measured.
OUTPUT DATA FORMAT		FMT1* FMT2 FMT3 FMT4	STANDARD FIELD* output only. STANDARD + FREQUENCY FIELD* output. STANDARD + STATUS FIELD* output. STANDARD + FREQUENCY + STATUS FIELD output.
CANCEL DATA		CL	

*: Default code.

*: See para. 3-71 Output Data.

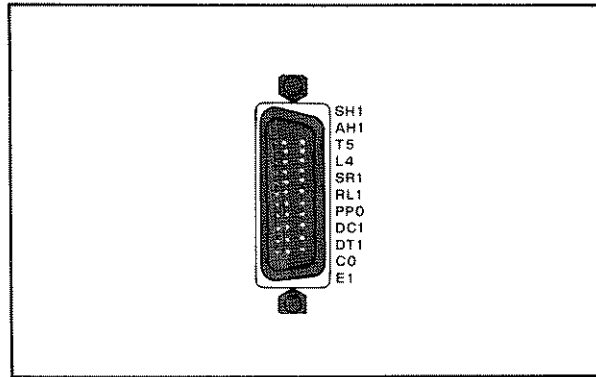

Figure 3-18. HP-IB Connector.

Sample Program 1

PURPOSE :

This program is a remote control, data output program for spot frequency measurement via the HP-IB.

9825A Program :

```

0: flt 3
1: clr 717
2: wrt 717,"FMT2T2"
3: wrt 717,"FR1EN"
4: wrt 717,"EX"
5: red 717,A,B,C,D,E,F,G
6: dsp C,D,G
7: prt C,D,G
8: end
*1785

```

HP-85 Program :

```

10 CLEAR 717
20 OUTPUT 717 "FMT2T2"
30 OUTPUT 717 "FR1EN"
40 OUTPUT 717 "EX"
50 ENTER 717 ; A,B,C,D,E,F,G
60 DISP C,D,G
70 PRINT C,D,G
80 END

```

Line		Description
9825A	HP 85	
1	10	Sets all 4193A's controls to Initial Control Settings.
2	20	Selects the data output format and the trigger mode. See para. 3-73.
3	30	Sets test frequency to 1MHz.
4	40	Triggers the 4193A.
5	50	Reads the output data from the 4193A.
6	60	Displays the magnitude, phase, and test frequency values on the controller's display.
7	70	Prints out the measurement data on the controller's printer.

To store the complete output data, the following program can be used :

9825A Program :

```

0: dim A#[100]
1: clr 717
2: wrt 717,"FMT4T2"
3: wrt 717,"FR1EN"
4: wrt 717,"EX"
5: red 717,A#
6: prt A#
7: end
*21373

```

HP-85 Program :

```

10 DIM A#[100]
20 CLEAR 717
30 OUTPUT 717 "FMT4T2"
40 OUTPUT 717 "FR1EN"
50 OUTPUT 717 "EX"
60 ENTER 717 ; A#
70 PRINT A#
80 END

```

Figure 3-19. Sample Program 1.

Sample Program 2

PURPOSE:

This program is a remote control, data output program for swept frequency measurement via the HP-IB.

9825A Program :

```

0: flt 3
1: clr 717
2: wrt 717,"FMT2T2"
3: wrt 717,"TF10ENPF2OENW1"
4: wrt 717,"EX"
5: red 717,A,B,C,D,E,F,G
6: prt C,D,G
7: if E=3;jmp 2
8: gto 4
9: end
*5830

```

HP-85 Program :

```

10 CLEAR 717
20 OUTPUT 717 "FMT2T2"
30 OUTPUT 717 "TF10ENPF2OENW1"
40 OUTPUT 717 "EX"
50 ENTER 717 ; A,B,C,D,E,F,G
60 PRINT C,D,G
70 IF E=3 THEN 90
80 GOTO 40
90 END

```

Line		Description
9825A	HP 85	
1	10	Sets all 4193A's controls to Initial Control Settings.
2	20	Selects the data output format and the trigger mode. See para. 3-73.
3	30	Sets the START frequency and STOP frequency for a PARTIAL sweep to 10MHz and 20MHz, respectively.
4	40	Triggers the 4193A.
5	50	Reads the output data from the 4193A.
6	60	Prints out the magnitude, phase, and test frequency data on the controller's printer.
7	70	When the test frequency reaches the STOP frequency, E changes from 1 to 3. See para. 3-72.

For FULL sweep measurement, the following program can be used :

9825A Program :

```

0: flt 3
1: clr 717
2: wrt 717,"FMT2T2W2"
3: wrt 717,"EX"
4: red 717,A,B,C,D,E,F,G
5: prt C,D,G
6: if E=3;jmp 2
7: gto 3
8: end
*12992

```

HP-85 Program :

```

10 CLEAR 717
20 OUTPUT 717 "FMT2T2W2"
30 OUTPUT 717 "EX"
40 ENTER 717 ; A,B,C,D,E,F,G
50 PRINT C,D,G
60 IF E=3 THEN 80
70 GOTO 30
80 END

```

Figure 3-20. Sample Program 2.

