

ACTUATOR/DIGITAL OUTPUT ASSEMBLY (OPTION 110)

44428A

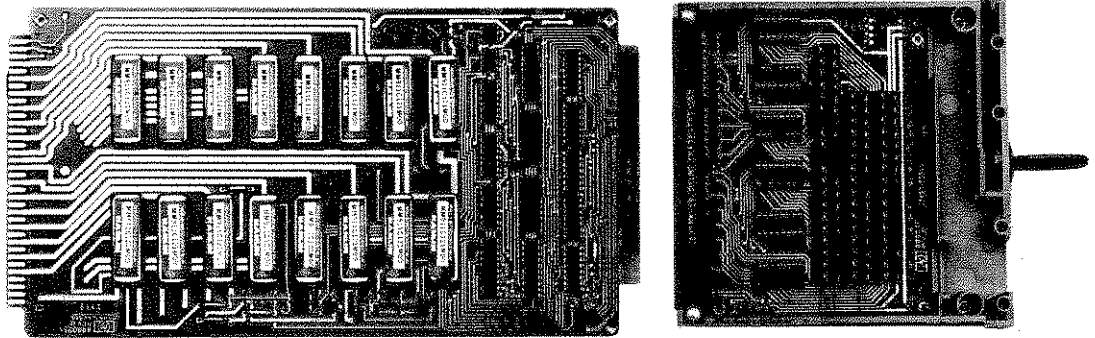

TABLE OF CONTENTS

Section	Page	Section	Page
I. GENERAL INFORMATION.....	1-1	4-5. Operational Verification.....	4-1
1-1. Introduction.....	1-1	4-7. Operational Verification Checks Using the Verification Connector.....	4-1
1-4. Description.....	1-1	4-9. Procedure.....	4-2
1-7. Specifications.....	1-1	4-10. Operational Verification Checks Using a Resistor Network.....	4-3
1-9. Actuator Cards Covered by this Manual.....	1-1	4-12. Terminal Card Wiring.....	4-3
1-11. Accessories.....	1-2	4-13. Procedure.....	4-4
1-13. Safety Considerations.....	1-2	4-15. Testing Relay Contact Resistance.....	4-4
1-15. Equipment Required but not Supplied.....	1-2	4-17. Testing Thermal Offset.....	4-5
1-17. Equipment Available.....	1-2	4-19. Procedure.....	4-5
II. INSTALLATION.....	2-1	V. ADJUSTMENTS.....	5-1
2-1. Introduction.....	2-1	5-1. Introduction.....	5-1
2-3. Initial Inspection.....	2-1	VI. REPLACEABLE PARTS.....	6-1
2-6. Preparation for Use.....	2-1	6-1. Introduction.....	6-1
2-15. Repacking for Shipment.....	2-4	6-4. Ordering Information.....	6-1
III. OPERATION.....	3-1	6-6. Non-Listed Parts.....	6-1
3-1. Introduction.....	3-1	6-8. Parts Changes.....	6-1
3-3. Actuator Card Commands.....	3-1	VII. MANUAL CHANGES.....	7-1
3-8. 3497A Front Panel Features.....	3-1	7-1. Introduction.....	7-1
3-12. Actuator Assembly Check Using the 3497A Front Panel.....	3-2	VIII. SERVICE.....	8-1
3-15. Step 1: Verify Card Signature.....	3-3	8-1. Introduction.....	8-1
3-18. Step 2: Reset.....	3-4	8-3. Safety Considerations.....	8-1
3-20. Step 3: Interrogate Relay Status.....	3-4	8-5. Block Diagram Theory of Operation.....	8-1
3-22. Step 4: Close Relays.....	3-4	8-10. Detailed Theory of Operation.....	8-1
3-24. Step 5: Open Relays.....	3-4	8-11. Relay Drivers.....	8-1
3-26. Actuator Assembly Test Using a Controller.....	3-4	8-14. Identity Register and Decoder.....	8-2
3-29. Actuator Applications.....	3-4	8-17. Flag and Gate Handshake.....	8-2
IV. VERIFICATION CHECKS.....	4-1	8-20. Troubleshooting Information.....	8-3
4-1. Introduction.....	4-1	8-22. Relay Decoding and Driving Circuits.....	8-3
4-3. Recommended Test Equipment.....	4-1	8-25. Control Logic.....	8-4
		8-27. Handshake Logic.....	8-4

LIST OF ILLUSTRATIONS

Figure	Page	Figure	Page
2-1. R-C Network Nomograph.....	2-2	4-1. Verification Connector.....	4-2
2-2. Relay Contact Protection Circuit.....	2-3	4-2. CRDVER Key Operations.....	4-3
2-3. Handshake Timing Diagram.....	2-3	4-3. Wiring the Terminal Block.....	4-4
3-1. Determining the Octal Value.....	3-1	4-4. Actuator/Digital Output Test Program.....	4-4
3-2. 3497A Front Panel Features.....	3-3	4-5. Relay Contact Resistance Test.....	4-5
3-3. Actuator Assembly Check Flowchart.....	3-4	6-1. Mechanical Parts.....	6-4
3-4. Actuator Assembly Check Using the 3497A Front Panel.....	3-5	8-1. Functional Block Diagram.....	8-2
3-5. Actuator Assembly Check Using an -hp- 85F.....	3-6	8-2. U3 Truth Table.....	8-2
3-6. Relay Actuated Alarm Circuit.....	3-7	8-3. Handshake Timing.....	8-3
3-7. Voltage Switching.....	3-7	8-4. Actuator Exercise Program.....	8-4
3-8. Bit Wide Digital Output Word.....	3-7	8-5. Actuator Assembly Card.....	8-5
3-9. Matrix Switching.....	3-7	8-6. Actuator Terminal Card.....	8-7

LIST OF TABLES

Table	Page	Table	Page
1-1. Specifications.....	1-2	4-3. Resistor Values.....	4-3
3-1. Actuator Assembly Commands.....	3-2	6-1. List of Abbreviations.....	6-1
4-1. Recommended Test Equipment.....	4-1	6-2. Code List of Manufacturers.....	6-2
4-2. Verification Connector and Software.....	4-1	6-3. Replaceable Parts.....	6-3



SAFETY SUMMARY

The following general safety precautions must be observed during all phases of operation, service, and repair of this instrument. Failure to comply with these precautions or with specific warnings elsewhere in this manual violates safety standards of design, manufacture, and intended use of the instrument. Hewlett-Packard Company assumes no liability for the customer's failure to comply with these requirements. This is a Safety Class 1 instrument.

GROUND THE INSTRUMENT

To minimize shock hazard, the instrument chassis and cabinet must be connected to an electrical ground. The instrument is equipped with a three-conductor ac power cable. The power cable must either be plugged into an approved three-contact electrical outlet or used with a three-contact to two-contact adapter with the grounding wire (green) firmly connected to an electrical ground (safety ground) at the power outlet. The power jack and mating plug of the power cable meet International Electrotechnical Commission (IEC) safety standards.

DO NOT OPERATE IN AN EXPLOSIVE ATMOSPHERE

Do not operate the instrument in the presence of flammable gases or fumes. Operation of any electrical instrument in such an environment constitutes a definite safety hazard.

KEEP AWAY FROM LIVE CIRCUITS

Operating personnel must not remove instrument covers. Component replacement and internal adjustments must be made by qualified maintenance personnel. Do not replace components with power cable connected. Under certain conditions, dangerous voltages may exist even with the power cable removed. To avoid injuries, always disconnect power and discharge circuits before touching them.

DO NOT SERVICE OR ADJUST ALONE

Do not attempt internal service or adjustment unless another person, capable of rendering first aid and resuscitation, is present.

DO NOT SUBSTITUTE PARTS OR MODIFY INSTRUMENT

Because of the danger of introducing additional hazards, do not install substitute parts or perform any unauthorized modification to the instrument. Return the instrument to a Hewlett-Packard Sales and Service Office for service and repair to ensure that safety features are maintained.

DANGEROUS PROCEDURE WARNINGS

Warnings, such as the example below, precede potentially dangerous procedures throughout this manual. Instructions contained in the warnings must be followed.

WARNING

Dangerous voltages, capable of causing death, are present in this instrument. Use extreme caution when handling, testing, and adjusting.

SAFETY SYMBOLS

General Definitions of Safety Symbols Used On Equipment or In Manuals.



Instruction manual symbol: the product will be marked with this symbol when it is necessary for the user to refer to the instruction manual in order to protect against damage to the instrument.



Indicates dangerous voltage (terminals fed from the interior by voltage exceeding 1000 volts must be so marked).

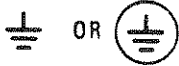

Protective conductor terminal. For protection against electrical shock in case of a fault. Used with field wiring terminals to indicate the terminal which must be connected to ground before operating equipment.



Low-noise or noiseless, clean ground (earth) terminal. Used for a signal common, as well as providing protection against electrical shock in case of a fault. A terminal marked with this symbol must be connected to ground in the manner described in the installation (operating) manual, and before operating the equipment.

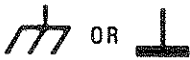

Frame or chassis terminal. A connection to the frame (chassis) of the equipment which normally includes all exposed metal structures.



Alternating current (power line).



Direct current (power line).



Alternating or direct current (power line).

WARNING

The **WARNING** sign denotes a hazard. It calls attention to a procedure, practice, condition or the like, which, if not correctly performed or adhered to, could result in injury or death to personnel.

CAUTION

The **CAUTION** sign denotes a hazard. It calls attention to an operating procedure, practice, condition or the like, which, if not correctly performed or adhered to, could result in damage to or destruction of part or all of the product.

NOTE :

The **NOTE** sign denotes important information. It calls attention to procedure, practice, condition or the like, which is essential to highlight.

OPERATING AND SERVICE MANUAL

MODEL 44428A ACTUATOR/DIGITAL OUTPUT ASSEMBLY (OPTION 110)

WARNING

Only personnel with knowledge of electronic circuitry should install, re-configure, or make repairs to this instrument.

The Actuator Card and associated terminal card were not intended for outdoor use. Do not expose them to rain or excessive moisture.

Manual Part Number 44428-90001

Microfiche Part Number 44428-90051

©Copyright Hewlett-Packard Company 1981
P.O. Box 301, Loveland, Colorado 80537 U.S.A.

Printed: January 1982



CERTIFICATION

Hewlett-Packard Company certifies that this product met its published specifications at the time of shipment from the factory. Hewlett-Packard further certifies that its calibration measurements are traceable to the United States National Bureau of Standards, to the extent allowed by the Bureau's calibration facility, and to the calibration facilities of other International Standards Organization members.

WARRANTY

This Hewlett-Packard product is warranted against defects in material and workmanship for a period of one year from date of shipment [except that in the case of certain components listed in Section I of this manual, the warranty shall be for the specified period] . During the warranty period, Hewlett-Packard Company will, at its option, either repair or replace products which prove to be defective.

For warranty service or repair, this product must be returned to a service facility designated by -hp-. Buyer shall prepay shipping charges to -hp- and -hp- shall pay shipping charges to return the product to Buyer. However, Buyer shall pay all shipping charges, duties, and taxes for products returned to -hp- from another country.

Hewlett-Packard warrants that its software and firmware designated by -hp- for use with an instrument will execute its programming instructions when properly installed on that instrument. Hewlett-Packard does not warrant that the operation of the instrument, or software, or firmware will be uninterrupted or error free.

LIMITATION OF WARRANTY

The foregoing warranty shall not apply to defects resulting from improper or inadequate maintenance by Buyer, Buyer-supplied software or interfacing, unauthorized modification or misuse, operation outside of the environmental specifications for the product, or improper site preparation or maintenance.

NO OTHER WARRANTY IS EXPRESSED OR IMPLIED. HEWLETT-PACKARD SPECIFICALLY DISCLAIMS THE IMPLIED WARRANTIES OF MERCHANTABILITY AND FITNESS FOR A PARTICULAR PURPOSE.

EXCLUSIVE REMEDIES

THE REMEDIES PROVIDED HEREIN ARE BUYER'S SOLE AND EXCLUSIVE REMEDIES. HEWLETT-PACKARD SHALL NOT BE LIABLE FOR ANY DIRECT, INDIRECT, SPECIAL, INCIDENTAL, OR CONSEQUENTIAL DAMAGES, WHETHER BASED ON CONTRACT, TORT, OR ANY OTHER LEGAL THEORY.

ASSISTANCE

Product maintenance agreements and other customer assistance agreements are available for Hewlett-Packard products.

For any assistance, contact your nearest Hewlett-Packard Sales and Service Office. Addresses are provided at the back of this manual.

GENERAL INFORMATION

SECTION I

1-1. INTRODUCTION

1-2. This Operating and Service Manual contains information necessary to install, configure, operate, test, and service the -hp- Model 44428A Actuator/Digital Output Assembly. The assembly is an option (Option 110) for the Hewlett-Packard Model 3497A Data Acquisition-Control Unit and 3498 Extender.

1-3. Overall system concepts, such as 3497A installation and operation, are covered in the Operating and Service Manual for the 3497A and will not be repeated in this manual.

1-4. DESCRIPTION

1-5. The -hp- Model 44428A Actuator/Digital Output assembly is comprised of two parts: the relay circuit board and the terminal card. See Figure 1-1. The assembly contains 16 mercury wetted form C (single poll, double throw) relays. Each relay can be individually closed or opened and can safely switch one ampere at 100 volts (peak). This makes the assembly ideal for switching power (actuating) to multiple external devices such as test fixture power or actuating an alarm. The relays were specially selected for "bounceless" switching, allowing the assembly to be used as a 16 bit wide digital output. Section III of this manual illustrates several typical applications for the assembly.

1-6. Other features of the 44428A assembly include isolated Flag and Gate handshake lines and internal (+5 volts non-isolated) or external (up to 100 volts) excitation. The assembly may also be configured as a 4X4 matrix.

1-7. SPECIFICATIONS

1-8. Table 1-1 provides the detailed specifications for the -hp- Model 44428A Actuator/Digital Output assembly.

1-9. ACTUATOR CARDS COVERED BY THIS MANUAL

1-10. Each relay card is identified by a part number, 03497-66514, and revision letter marked on the component side of the circuit board. This manual applies to cards with the model number indicated on the title page. If changes have been made on this assembly after the manual was printed, a yellow "MANUAL CHANGES" supplement sheet will be supplied with the manual. This yellow sheet defines and explains each change and how to adapt the manual to the newer assemblies. In addition, backdating information contained in Section VII of this manual adapts the manual to earlier versions of the assembly.

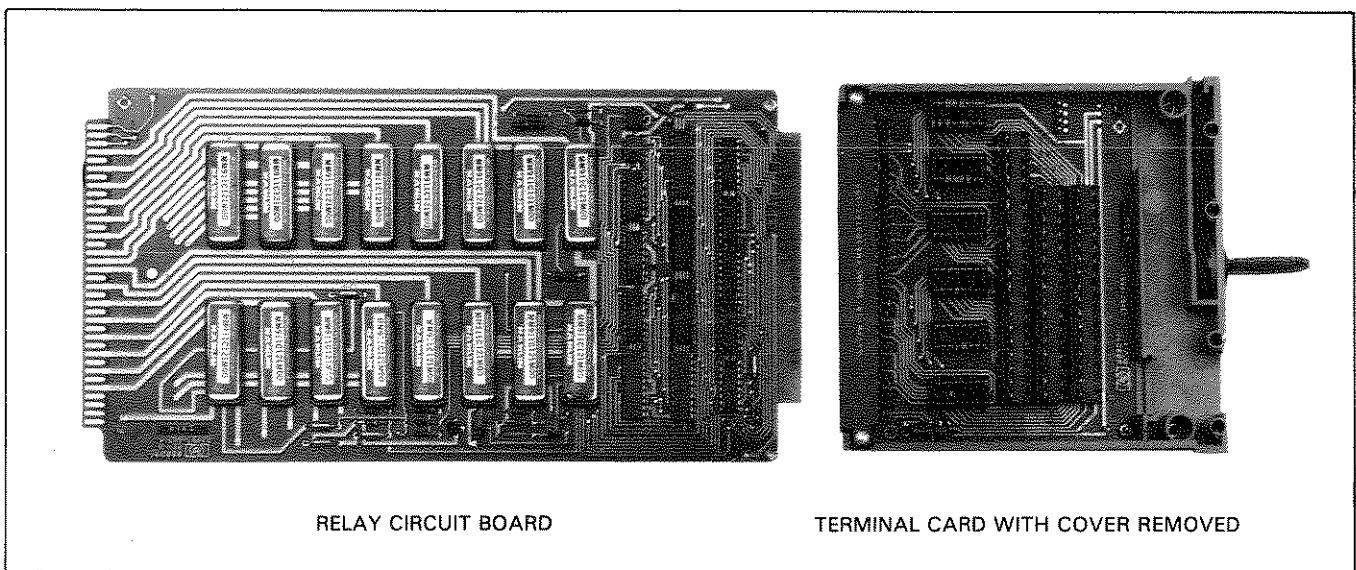



Figure 1-1. -hp- Model 44428A Actuator/Digital Output Assembly

1-11. ACCESSORIES

1-12. An -hp- Model 03497-66515 actuator terminal card is supplied with each assembly.

1-13. SAFETY CONSIDERATIONS

1-14. This manual contains cautions and warnings alerting the user to hazardous operating and maintenance conditions. This information is flagged by a CAUTION or WARNING heading and/or the symbol . The symbol flags important operating instructions located in Section III. To ensure the safety of the operating and maintenance personnel and retain the

operating condition of the instrument, these instructions must be adhered to.

1-15. EQUIPMENT REQUIRED BUT NOT SUPPLIED

1-16. The 44428A Actuator/Digital Output assembly was designed to operate with the -hp- Model 3497A Data Acquisition-Control Unit or with the -hp- Model 3498A Extender to the 3497A.

1-17. EQUIPMENT AVAILABLE

1-18. An extender board (-hp- part number 03497-67913) is available as an aid in troubleshooting the actuator card.

TABLE 1-1. Specifications

INPUT CHARACTERISTICS	AC PERFORMANCE
<div data-bbox="415 774 574 838" style="text-align: center;"></div> <p><i>The actuator is for use only in circuits fused at 1 ampere or less and less than 100VA.</i></p>	<p>Contact Capacitance: < 15 pF Interchannel Capacitance: < 30 pF Frequency Response: (10kHz Reference) $f < 100\text{kHz}$ $f < 1\text{MHz}$ 50 Ohm Termination +/- .3dB +/- .5dB 1M Ohm Termination +/- .3dB +/- .5dB</p>
<p>Contact Ratings:</p> <p>Voltage: +/- 100 volts peak Current: 1 ampere/channel Power: 100 volt amperes/channel</p>	<p>Cross Talk: 1M Ohm Termination < 30 dB < 30 dB</p>
<p>Thermal Offset: < 20 uV</p>	GENERAL INFORMATION
<p>Contact Resistance: < 400 milliohms</p>	<p>Single Contact Closure Rate: > 27 closures/second (using an -hp- Model 9835A Desk top Computer</p>
<p>Isolation: > 10⁶ ohm common to open</p>	<p>Switch Life: > 10¹⁰ operations with proper contact protection (see Section II)</p>
<p>Isolation Voltage: 170V peak any terminal to chassis</p>	<p>Operating Considerations: The 44428A assembly must not be used in a position greater than 30 degrees from vertical.</p>
	<p>Inductive loads may require external arc suppression.</p>

INSTALLATION

SECTION II

WARNING

Only qualified service trained personnel are to install, re-configure, or make repairs to this assembly. Use clean handling techniques (antistatic techniques) when inspecting, removing, replacing or re-configuring the assembly. Handle the card by its edges and do not subject the components to static discharge or excessive voltages. To prevent serious personal injury, extreme caution must be exercised when working with optional plug-in cards. Potential shock hazards (voltages up to 170 volts peak) can exist between exposed guard and chassis on both the front (when front panel is open) and the rear of the 3497A/3498A (when safety cover is removed). Disconnect 3497A/3498A power cord, disconnect all input/output lines to/from the mainframe and option cards and make certain that wires to the actuator terminal cards are free of voltage sources prior to handling or inserting or extracting the assembly.

2-1. INTRODUCTION

2-2. This section contains information and instructions for configuring, installing, and shipping the -hp- Model 44428A Actuator/Digital Output assembly. Included are initial inspection procedures, power requirements, interconnection and relay contact protection instructions.

2-3. INITIAL INSPECTION

CAUTION

Use clean handling techniques (antistatic techniques) when inspecting, removing, installing, and configuring the assembly. Handle the card by its edges and do not subject the components to static discharge or excessive voltages.

2-4. Inspect the shipping container for damage. If the shipping container or cushioning material is damaged, it should be kept until the contents of the shipment have been checked for completeness and the assembly has been checked mechanically and electrically.

2-5. The assembly was carefully inspected both mechanically and electrically before shipment. It should be in proper working order upon receipt. To confirm this, the assembly should be carefully inspected for physical damage, and the electrical performance should be tested using the performance tests outlined in Section V.

2-6. PREPARATION FOR USE

CAUTION

To avoid the possibility of circuit damage, always remove the power cord from the 3497A/3498A before removing or installing any plug-in option assemblies.

External circuits connected to the -hp- Model 44428A Actuator/Digital Output assembly must be fused at 1 ampere or less, and rated at 100VA or less per channel. Voltages must not exceed +/- 100 volts peak.

To achieve maximum relay contact life and prevent RFI from radiating if arcing occurs, R-C relay contact protection is required when loads greater than 12 volts at 65 mA. are connected to the assembly. Use the nomograph in Figure 2-1 to determine the correct value of R and C. Use R-C networks on both the NO and NC contacts if both contacts are switching power levels requiring this protection; see Figure 2-2.

2-7. **Power Requirements.** Power for the operation of the plug-in assembly is provided by the 3497A or 3498A main frame.

2-8. **Interconnections.** Remove the cover on the -hp- Model 03497-66515 Actuator Terminal Card and connect the devices that will be actuator controlled to the appropriate terminals -- Normally Open (NO), Normally Closed (NC), and Common (C). Route the wires through the strain relief cutouts. Replace the cover and plug the terminal card on to the actuator relay circuit board. Next, insert the assembly into the desired slot in the main frame.

2-9. Remember that the arrows on the relays must always point upward (12 O'clock position). Gently tap

CONTACT PROTECTION

Contact loads that can cause arcing may result in contact failure unless contact protection is provided. It should be wired close to the relay terminals.

The R-C network shown is suitable for most loads. Component values may be obtained from the nomograph. Capacitance may be increased (up to 10 times) to minimize inductive load transients. Use peak values for ac circuits.

No protection is required for voltages below 12 volts or currents below 65ma.

The resistor may be eliminated for voltages below 50 volts with currents below 0.5A. The capacitor should not exceed the chart value.

Highly capacitize loads do not require protection.

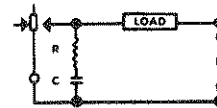

CONTACT PROTECTION NOMOGRAPH

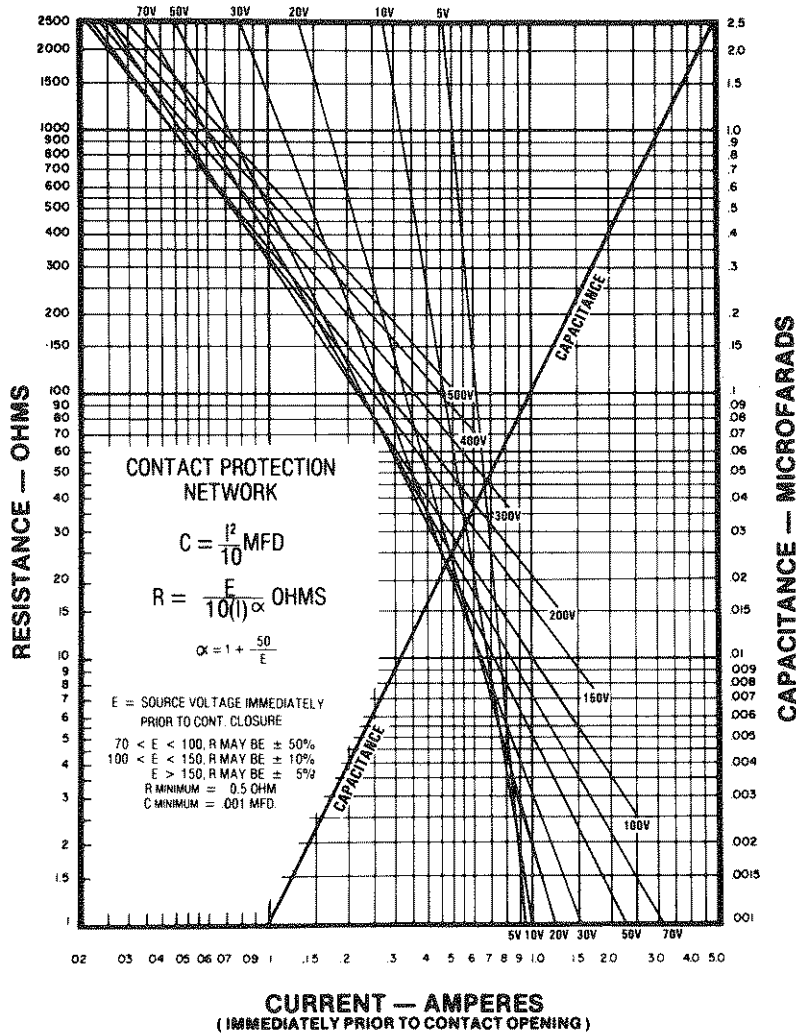

HOW TO USE THE NOMOGRAPH

To determine C, the load current value is found on the CURRENT axis. Reading directly up to the sloping capacitance line, the C value is determined from the right hand CAPACITANCE scale. To determine R, read directly up from the load current value to its intersection with the appropriate load voltage line. The value of R is then read from the left hand RESISTANCE scale. For ac loads, peak current and voltage values must be used.

Figure 2-1. R-C Network Nomograph
(Courtesy C.P. Clare & Company)

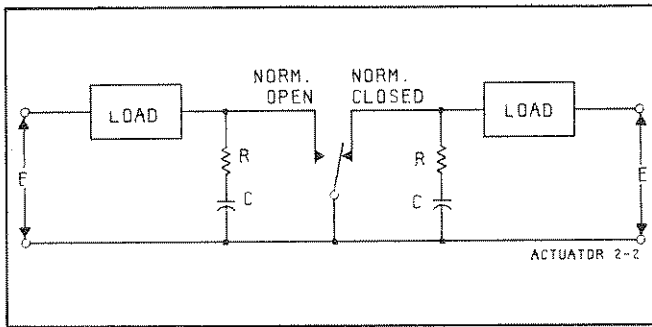

Figure 2-2. Relay Contact Protection Circuit

the actuator assembly (after insertion in the 3497A or 3498A mainframe) to settle the mercury to the bottom of the relay.

2-10. Relay Board Configuration. The gate and flag handshake lines were designed to operate with standard TTL logic levels. Diode protection is used on both the gate and flag lines. These lines are optically isolated from the actuator board when the Terminal Card jumpers 1, 2, 3, and 4 are open.

2-11. Gate Handshake Lines. Either a positive going gate pulse (LGT) or a negative going gate pulse (HGT) can be selected with the actuator board plug P1a. In either case, the trailing edge of the gate pulse would be used by the external circuitry utilizing this handshake capability. The leading edge of this pulse coincides with K0-K15 switching and the trailing edge indicates that the relay (or data) output is stable. Refer to Figure 2-3 for handshake timing. A typical application would have the Gate-terminal connected to external circuit common and the Gate+ terminal connected (with external pull-up resistor, minimum value 10K ohm) to a TTL input.

2-12. Flag Handshake Lines. Flag inputs to the assembly are used to signify that the external circuitry has completed data transfer and are now ready to receive additional output from the actuator assembly. Either a positive going flag or a negative going flag may be used. A typical application would have the Flag+ line connected to the external circuitry +5 volt supply and the Flag- line driven by a TTL device. Jumper plug P2 on the relay circuit board allows on/off selection of the Flag handshake mode.

2-13. Terminal Card Configuration. If jumpers 1, 2, 3, and/or 4 on the 03497-66515 terminal card are used, the handshake lines are no longer optically isolated. For example, with the Gate jumpers, a 10K ohm resistor can be connected in place of J1 and J2 would be a short piece of wire. This would eliminate using an external pull-up resistor.

2-14. An example using the Flag lines would be to connect jumper J3 (short piece of wire) and connect a switch across J4. Now, the flag handshake would be activated by closing the switch.

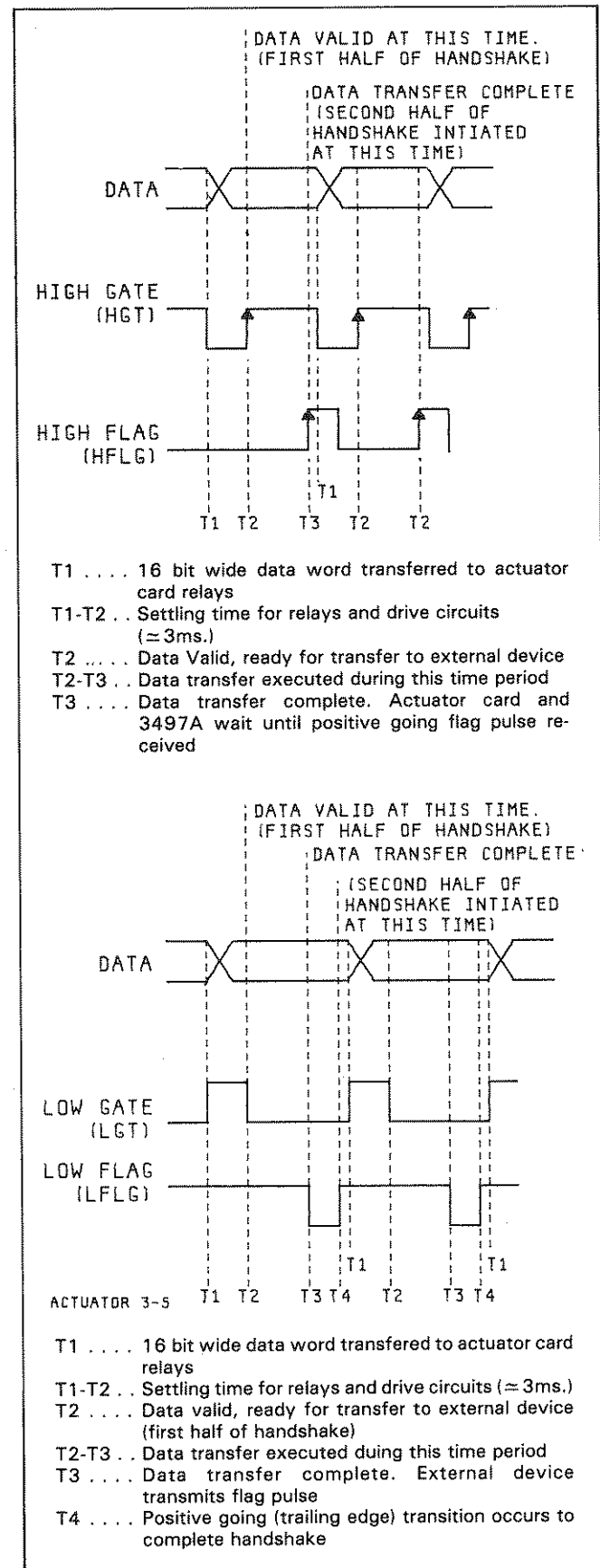

Figure 2-3. Handshake Timing Diagram

2-15. REPACKING FOR SHIPMENT

2-16. Tagging For Service. If the actuator assembly is being returned to Hewlett-Packard for service, please attach a tag to the assembly indicating the nature of the problem, return address, person to contact, phone number, and complete model and serial number.

2-17. Packing. When shipping the assembly, it is recommended that the original packing material be used. Antistatic packing material should be used when

shipping. DO NOT wrap in ordinary plasti-bubble pack. If proper materials are not available, contact your local Hewlett-Packard Sales and Service office to obtain adequate materials. If the assembly is being returned for service, the office will also provide the address of the nearest service office to which the assembly should be sent. Mark the package FRAGILE to insure careful handling. In any correspondence concerning the assembly, refer to the assembly by complete model and serial number.

OPERATION

SECTION III

3-1. INTRODUCTION

3-2. This operating section lists and describes commands applicable to the -hp- Model 44428A Actuator/Digital Output assembly. This section describes a simple operator verification and several typical applications for the actuator assembly. A general discussion of 3497A front panel features and a general discussion of commands is also provided.

3-3. ACTUATOR CARD COMMANDS

3-4. In the Actuator/Digital Output assembly any combination of relays (channels) may be opened or closed simultaneously. This is done by specifying the slot number where the assembly is located and the channels to be opened or closed. As shown in Table 3-1 the primary commands for controlling the actuator assembly are the DCn,n1,n2,...n16 (Digital Close); DOn,n1,n2,...n16 (Digital Open); and DWn,n1 (Digital Write).

3-5. The Digital Open and Digital Close commands are used to open or close specified channels while leaving other channels not specified in their previous state. The DO and DC commands use the form DOn,n1,n2,...n16 and DCn,n1,n2,...n16 (respectively) where n is the slot number where the assembly is located (0-4 in the 3497A). Individual channels to be opened or closed are represented by n1,n2,...n16; n1 is one channel to be opened or closed, n2 is a second channel, etc. For example, to close channels 5, 7, 10, and 15 on the assembly located in slot 1, use the command:

DC1,5,7,10,15

Note that all other channels remain in their previous state, either open or closed.

3-6. The DO and DC commands affect only the channels specified. The DW command, on the other hand, provides a simple method of controlling all relays with a single command. By way of illustration, assume that an

actuator assembly in Slot #1 has some combination of open and closed relays. You need to have closed only channels 5, 7, 10, and 15. Using the DO and DC commands you might first open all channels and then close only the four needed, for example:

DO1,0,1,2,3,4,6,8,9,11,12,13,14

DC1,5,7,10,15

This is a two step process and very time consuming. The DW command performs the same task in one step (read paragraph 3-7):

DW1,102240

3-7. The Digital Write command has the form DWn,n1 where n1 is the octal value of the assembly state after the command has been executed. Therefore, the DW command affects all channels. To use the DW command, first decide what state you want the individual channels to be in after the command is executed. Use a "1" to indicate a closed channel, and a "0" to indicate an open channel. Then determine the octal value of the assigned state. For example, in paragraph 3-6 the command DW1,102240 was given. The value 102240 was determined as in Figure 3-1.

3-8. 3497A FRONT PANEL FEATURES

3-9. As shown in Figure 3-2, each key on the alphanumeric keyboard has three functions: the primary function indicated above the key; the numeric function printed on the key cap (i.e., 0-9, "-", and ","); and the shift or ALPHA mode (A, C, D, etc.) printed to the lower right of each key. The blue SHIFT key shifts the keyboard to the ALPHA mode.

3-10. There are two ways the DO and DC commands can be executed. Digital Close can be initiated by using the Digital Close key (numeric 8, without any previous keys pressed) or by pressing the blue SHIFT key followed by D (numeric 9) and C (numeric 8). In either case,

channel number	15	14	13	12	11	10	9	8	7	6	5	4	3	2	1	0
channel state	1	0	0	0	0	1	0	0	1	0	1	0	0	0	0	0
octal value	1	0			2		2		4			0				

Figure 3-1. Determining the Octal Value

Table 3-1. Actuator Assembly Commands

Command	Function and Description	Command	Function and Description
DCn,n1,n2,n3,.....,n16	<p>DIGITAL CLOSE (SLOT),(CHANNELS)</p> <p>Digital Close is used to close relay contacts in channels n1 through n16. From one to sixteen channels of an actuator in slot n may be closed with a single command. n = the slot number. n1,n2, etc = number(s) of channel(s) to be closed. Channels not listed in the command remain in their previous state. Example: DC2,4,5 closes relays in channels 4 and 5 for an actuator in slot 2, while relays in all other channels remain in their previous (open or closed) state.</p>	DVn	<p>DIGITAL VIEWED (SLOT)</p> <p>DIGITAL VIEWED command dedicates the 3497A front panel display to a slot while the 3497A is simultaneously in an output mode for another slot. For example, DV2 dedicates the front panel display to slot 2 at the same time that the 3497A is providing output data from another slot. Exit from this mode by using the command DV without the n (slot) designation.</p>
DO n,n1,n2,n3,.....,n16	<p>DIGITAL OPEN (SLOT),(CHANNELS)</p> <p>Digital Open is used to open relay contacts in channels n1 through n16 of an actuator in slot n. From one to sixteen channels may be opened by a single command. n= the slot number. n1, n2, etc = number(s) of channels to be opened. Channels not listed in the command remain in their previous state. Example: DO3,6,7 opens relays in channels 6 and 7 for an actuator in slot 3.</p>	DWn,n1	<p>DIGITAL WRITE (SLOT), (VALUE)</p> <p>The DIGITAL WRITE command outputs a 3 digit octal value to all 8 channels, where n is the slot number. n1 is the octal value corresponding to the desired digital state of the relays, where digital 1 = Closed, 0 = open. Thus, to close all relays, n1 = 177777; to open all relays, n1 = 0. To close relays in channels 5 and 6 only and open all other channels, (digital 01100000), n1 = 140. DW affects the entire assembly, while DC and DO affect only the channels specified.</p>
DLn	<p>DIGITAL LOAD (SLOT)</p> <p>The digital load command returns the current state of the 8 relays (open or closed) of an actuator in slot n for presentation on either the front panel of the 3497A and/or to the HP-IB bus. The presentation is a 6 digit octal representation of the state. For example, with all relays closed, the presentation is 177777 OCTAL.</p>	SI	<p>SYSTEM INITIALIZE</p> <p>This command is used to reset the actuator card channels to a power-on state which opens all relays. The SI command also resets the 1.5 second time delay circuit to zero.</p>
DRn	<p>DIGITAL READ (SLOT)</p> <p>Same as the DIGITAL LOAD command, except that repeated reads of the actuator card are made and updated on the display and on the HP-IB Interface Bus.</p>	SRn,0	<p>SYSTEM READ (SLOT),0</p> <p>This command reads the "signature" of the option card in slot n. The actuator is assigned signature 000041 OCTAL.</p>

the slot number, a comma, and the channel(s) must follow the command. For example:



OR

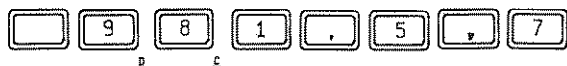

3-11. Later in this chapter more illustrations will be provided to demonstrate how the digital commands may be used with the actuator assembly. However, with this introduction to using the actuator assembly and digital commands, it is time to perform a simple verification check on the actuator assembly.

3-12. ACTUATOR ASSEMBLY CHECK USING THE 3497A FRONT PANEL

3-13. This actuator card check has two main objectives: to check the "signature" of the actuator card and check the readback function. In the process of performing this test you will learn about reading the 3497A display, interrogating relay status, and using other digital commands.

3-14. To begin the check make certain that the handshake jumper (P1) is in the off position. Firmly seat the actuator assembly in one of the slots in the 3497A. Press the 3497A LINE switch ON and follow the test sequence shown in Figure 3-3 and 3-4 and described in paragraphs 3-15 through 3-25.

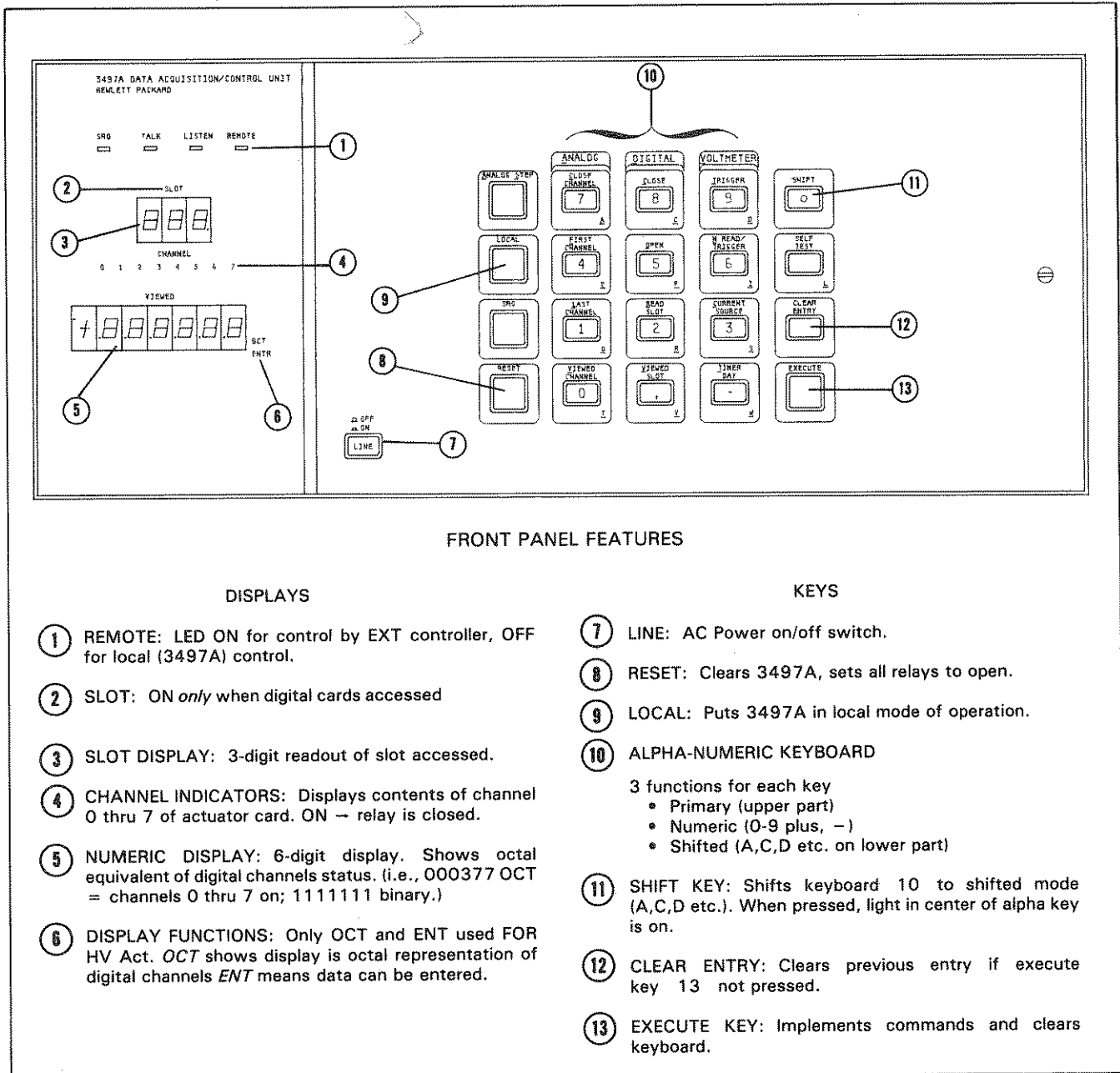

FRONT PANEL FEATURES

DISPLAYS

- ① REMOTE: LED ON for control by EXT controller, OFF for local (3497A) control.
- ② SLOT: ON *only* when digital cards accessed
- ③ SLOT DISPLAY: 3-digit readout of slot accessed.
- ④ CHANNEL INDICATORS: Displays contents of channel 0 thru 7 of actuator card. ON — relay is closed.
- ⑤ NUMERIC DISPLAY: 6-digit display. Shows octal equivalent of digital channels status. (i.e., 000377 OCT = channels 0 thru 7 on; 1111111 binary.)
- ⑥ DISPLAY FUNCTIONS: Only OCT and ENT used FOR HV Act. *OCT* shows display is octal representation of digital channels *ENT* means data can be entered.

KEYS

- ⑦ LINE: AC Power on/off switch.
- ⑧ RESET: Clears 3497A, sets all relays to open.
- ⑨ LOCAL: Puts 3497A in local mode of operation.
- ⑩ ALPHA-NUMERIC KEYBOARD
 - 3 functions for each key
 - Primary (upper part)
 - Numeric (0-9 plus, -)
 - Shifted (A,C,D etc. on lower part)
- ⑪ SHIFT KEY: Shifts keyboard 10 to shifted mode (A,C,D etc.). When pressed, light in center of alpha key is on.
- ⑫ CLEAR ENTRY: Clears previous entry if execute key 13 not pressed.
- ⑬ EXECUTE KEY: Implements commands and clears keyboard.

Figure 3-2. 3497A Front Panel Features

3-15. STEP 1: VERIFY CARD SIGNATURE

3-16. The actuator card has been assigned a signature of 000041 (octal). The purpose of the signature is to verify that an actuator assembly does exist in a specified 3497A slot. At the completion of this portion of the check, the 3497A front panel display should indicate 00041 OCT. Any other number indicates a different option card assembly, no option card, or a faulty actuator assembly or mainframe. If you should get a different number, try placing the actuator assembly in a different 3497A slot and rerun the test.

NOTE

The -hp- Model 44431A, 8 Channel High Voltage Actuator (Option 115), also has a signature of 00041 octal.

3-17. Figure 3-4, step 1, demonstrates the keystroke sequence for the signature test. Pressing the blue SHIFT key changes the front panel key functions to the shifted alpha (A, C, D, etc.) mode, so that the first two keystrokes are S and R (for System Read). The slot number is then entered (1 to 4), a comma, and then a

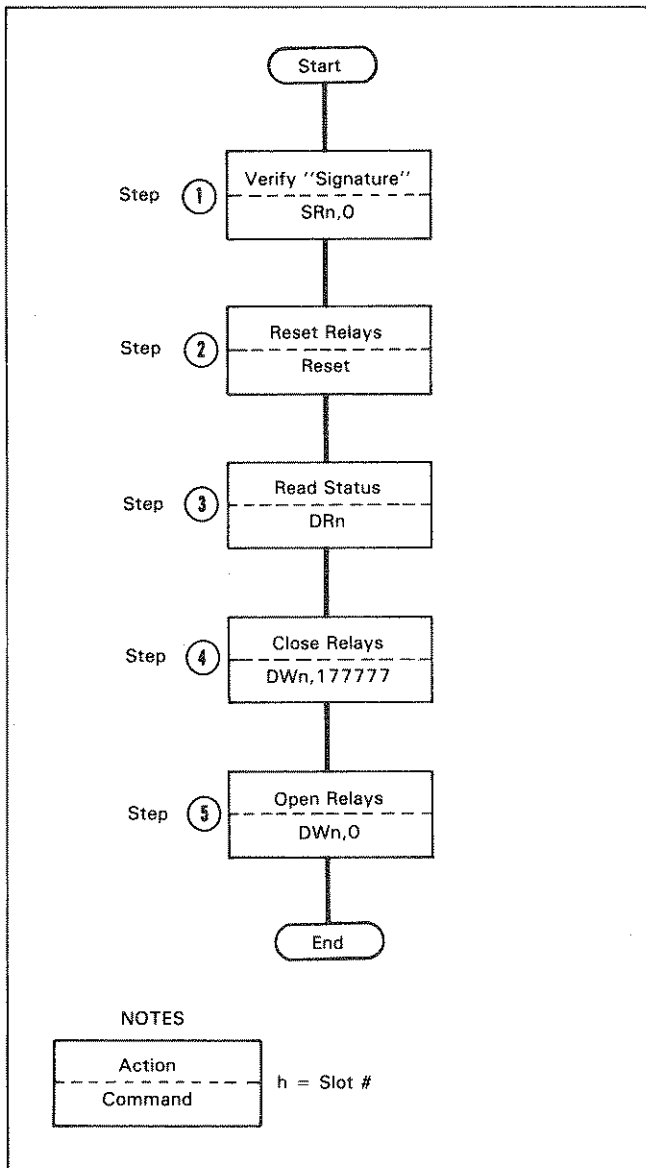

Figure 3-3. Actuator Assembly Check Flowchart

“0”. After the EXECUTE key is pressed, the slot number, channels 0 and 5 and 000041 OCT will be displayed.

NOTE

Channel indicators 0 and 5 ON do not indicate that relays (channels) 0 and 5 are closed. For the SRn,0 command, they correspond to 000041 Octal.

3-18. STEP 2: RESET

3-19. Press the 3497A RESET key to make certain that all relays are open. See Figure 3-4, step 2.

3-20. STEP 3: INTERROGATE RELAY STATUS

3-21. Use the DRn command to check the actuator readback function. The readback function allows you to

determine from the 3497A front panel which relays are closed and which are open. Figure 3-4, step 3, shows the keystroke sequence to read the relay status of the actuator assembly in slot n. Since the RESET key was pressed, all relays are open, the slot number and 000000 OCT will be displayed and all channel indicators will be off.

3-22. STEP 4: CLOSE RELAYS

3-23. Execute the command: DWn,17777 to close all relays as shown in Figure 3-4, step 4. After the EXECUTE key is pressed, the display will indicate the slot number, channel indicators 0 through 15, and 177777 OCT on the 3497A display. This indicates that all sixteen relays are closed.

3-24. STEP 5: OPEN RELAYS

3-25. Execute the DWn,0 command to open all relays. This is shown in Figure 3-4, step 5. After pressing the EXECUTE key, the 3497A display will indicate the slot number, 000000 OCT, and all channel indicators off. This completes the front panel verification of the -hp- Model 44428A Actuator/Digital Output assembly.

3-26. ACTUATOR ASSEMBLY TEST USING A CONTROLLER

3-27. The actuator assembly test can also be executed from an external computer/controller. The test setup shown in Figure 3-5 uses an -hp- Model 85 computer and HP-IB interface to control the 3497A. If your 3497A uses an RS-232 Serial Interface, the -hp- 85 Option 001 Interface System must be used. If you use another controller, the interface system must be compatible with the 3497A under test.

3-28. As with the manual front panel test, there are two test objectives: to verify the assembly signature and to check the readback function. The test setup, using an -hp- Model 85, and a sample program to test the assembly are shown in Figure 3-5. If you are using another controller, the flowchart of Figure 3-3 will help in writing a test program.

3-29. ACTUATOR APPLICATIONS

WARNING

Only qualified service trained personnel are to install, re-configure, or make repairs to this assembly. Use clean handling techniques (antistatic techniques) when inspecting, removing, replacing or re-configuring the assembly. Handle the card by its edges and do not subject the components to static discharge or excessive voltages. To prevent serious personal injury, extreme caution must be exercised when working with optional plug-in cards.

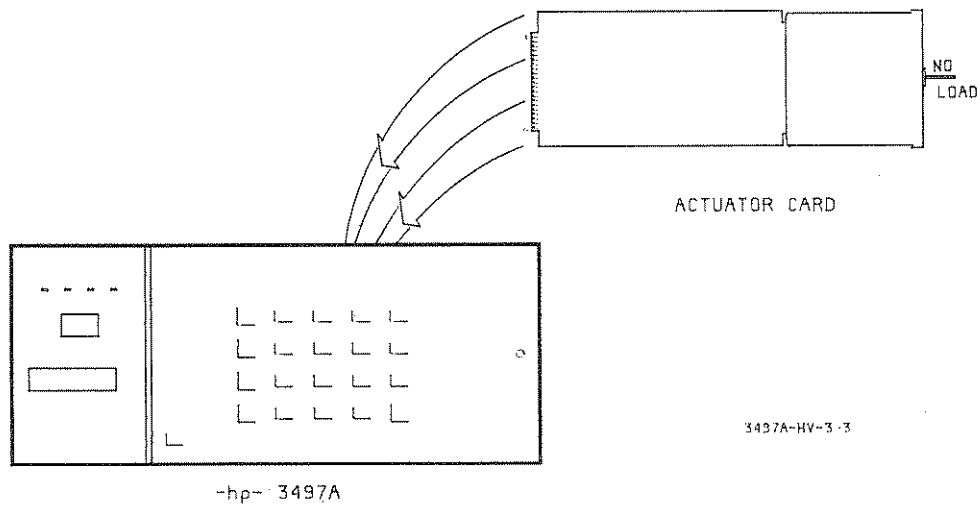

SETUP:

1. Line switch OFF
2. Insert card in desired slot
3. Line switch ON

Step #	Test	(See Table 3-1) Commands	Keystroke Sequence	Display	Remarks
1	Verify Card Signature	SRn,0 n = slot #		Slot n Channel 0 5 000041 OCT	000041 OCT identifies card in slot n as high voltage actuator (or Option 110 card).
2	Reset	Reset		Slot — Channel —	Reset opens all relays.
3	Read Relay Status	DRn n = Slot #		Slot n Channel (blank) 000000 OCT	000000 OCT indicates all relays open (0 state)
4	Close relays	DWn, 17777		Slot n Channel 0123456 000377 OCT	000377 OCT indicates all relays in Channels 0 thru 7 closed.
5	Open relays	DWn,0		Slot n Channel (blank) 000000 OCT	000000 OCT indicates all relays in Channels 0 thru 7 open.

Figure 3-4. Actuator Assembly Check Using The 3497A Front Panel

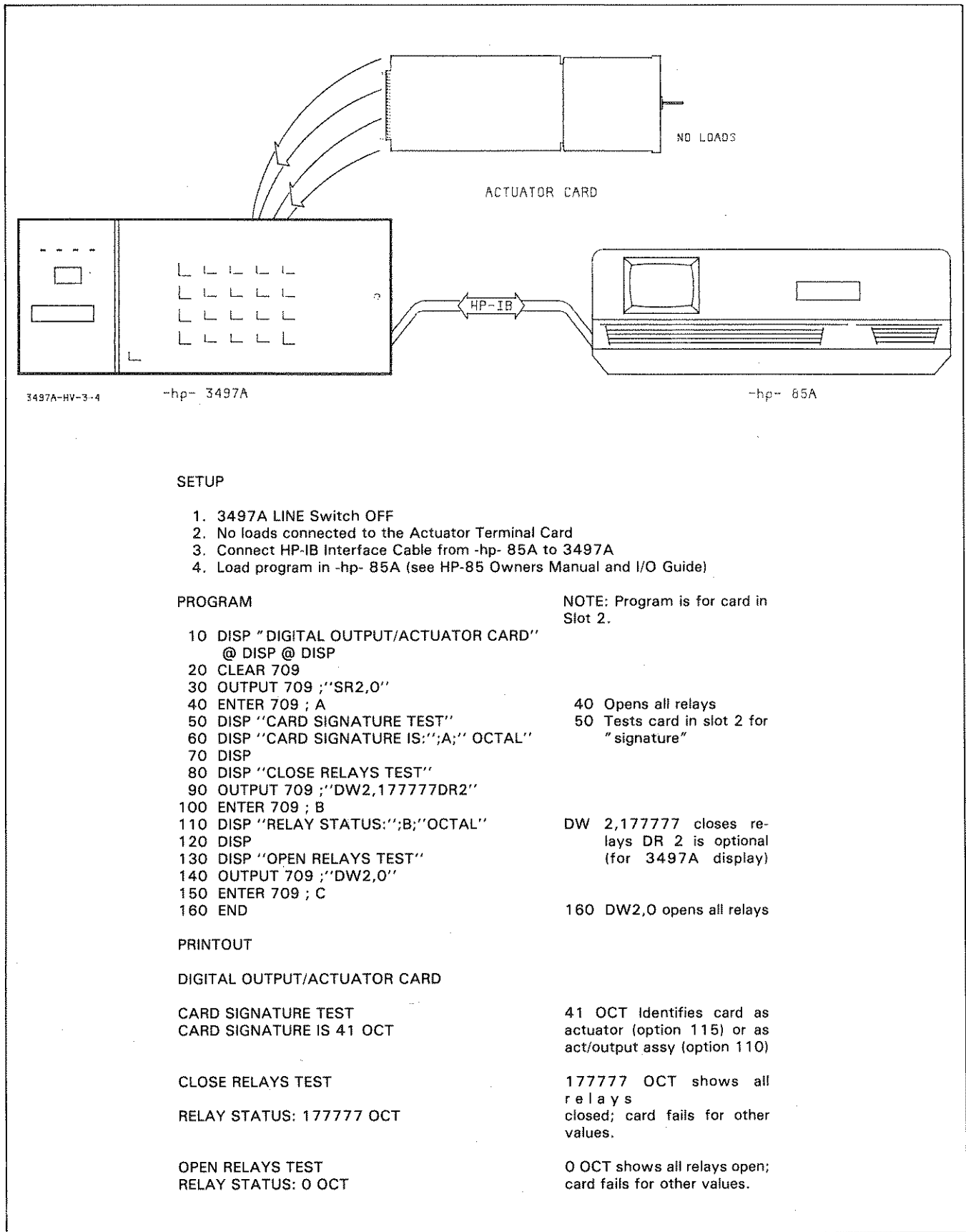

Figure 3-5. Actuator Assembly Check Using an -hp- 85F

3-30. The following paragraphs describe typical applications for the -hp- Model 44428A Actuator/Digital Output assembly. The examples given are not the only uses for the Actuator assembly, they only serve to show the versatility of the assembly. Numerous switching requirements can be satisfied, keeping in mind the maximum power limitations and other characteristics given in Table 1-1.

3-31. Highly inductive loads, such as motors and lamps, or capacitive loads may require relay contact arc protection. Refer to the nomograph in Section II for details on R-C network contact protection.

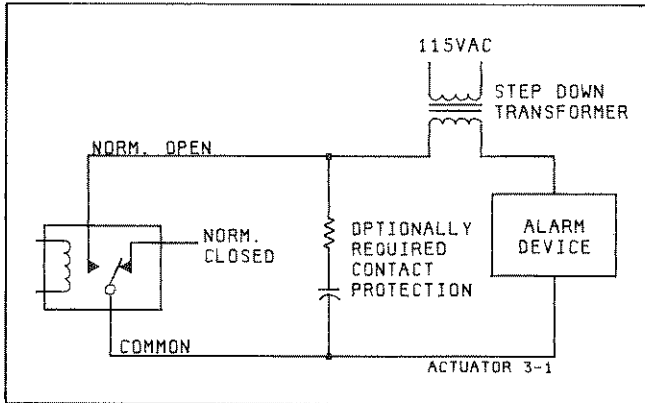

Figure 3-6. Relay Actuated Alarm Circuit

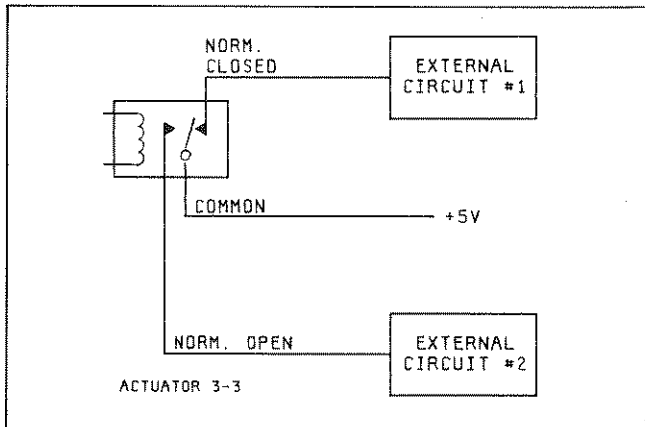

Figure 3-7. Voltage Switching

3-32. The 16 Mercury wetted relay switches (Single Pole, Double Throw) contained on the assembly can be individually controlled to close an external circuit such as actuating an alarm (Figure 3-6). Voltage can also be switched from one external device to another as shown in Figure 3-7.

3-33. A 16 bit wide digital word can be utilized by connecting the relay contacts on the terminal card as shown in Figure 3-8. The 16 pin DIP sockets and plugs (J1 through J6) on the Terminal Card provide a means of connecting the 4.7K ohm pull-up resistors to the Normally Open and Normally Closed relay contacts. Do not use pull-up resistors less than 2K ohms.

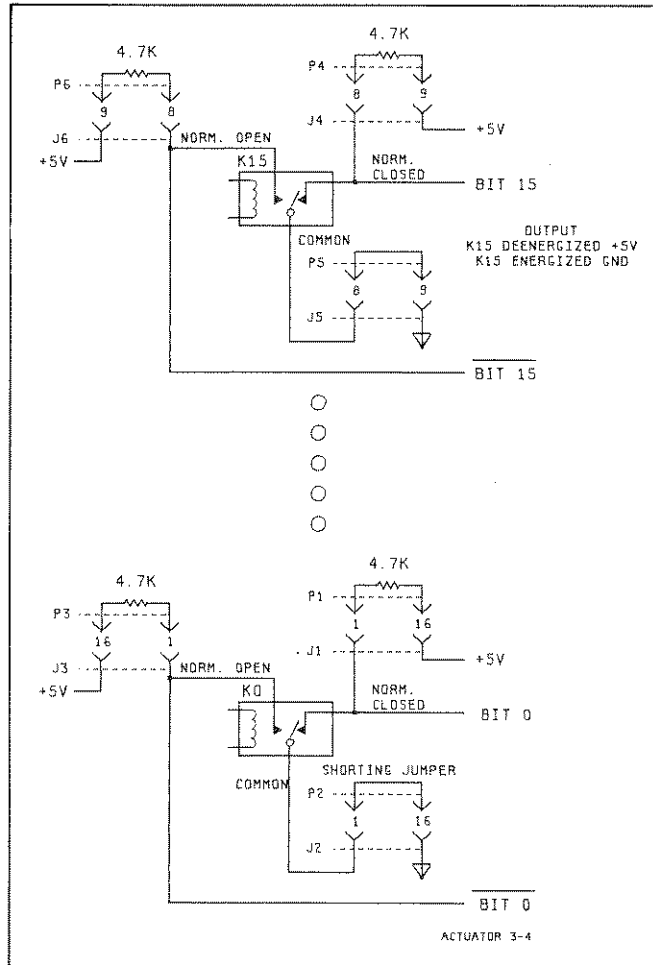

Figure 3-8. Bit Wide Digital Output Word

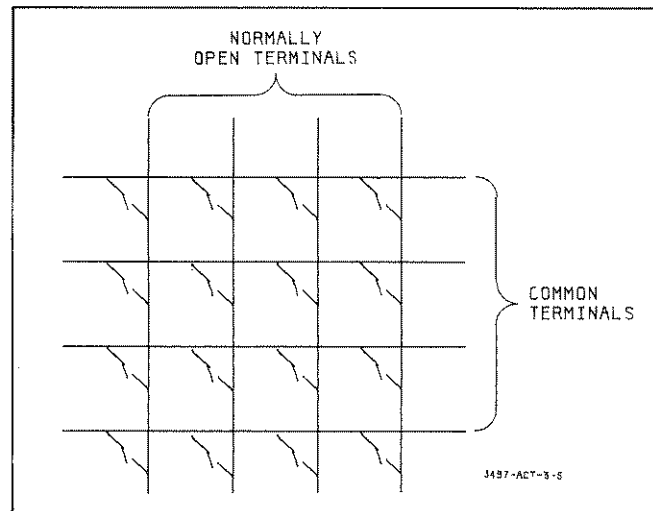

Figure 3-9. Matrix Switching

3-34. Figure 3-9 illustrates one type of matrix switching arrangement the Actuator assembly can be used for. All COMMON relay contacts are wired together in this application. Two relays would need to be closed simultaneously, typically one relay across the top and one along the left side.

SECTION IV

VERIFICATION CHECKS

4-1. INTRODUCTION

4-2. This section of the manual provides operational verification checks for the -hp- Model 44428A Actuator/Digital Output assembly. These checks are designed to verify the operational readiness of the assembly and does not perform specification checks. In addition, instructions are provided for testing relay contact resistance and thermal offset.

4-3. Recommended Test Equipment.

4-4. Test Equipment required to check the 44428A Actuator assembly is listed in Table 4-1. If any of the recommended test equipment, except for the 3497A and the 03497-67908 Verification Connector, is not available, substitutions may be made. Table 4-1 lists the critical specifications for the equipment.

4-5. OPERATIONAL VERIFICATION

4-6. Two forms of operational verification checks are discussed. The first assumes that you have the 03497-67908 Verification Connector and associated computer software. Refer to Table 4-2. The second verification check uses a resistor network that must be assembled on the actuator terminal card. Either test may be used, although the first is the preferred method

Table 4-2. Verification Connector and Software

-hp- Computer	-hp- Part Number (software only)	-hp- Part Number (software plus verification connector)
85A	03054-10011	03497-67909
9825A	03054-10008	03497-67910
9835A	03054-10002	03497-67911
9845A	03054-10005	03497-67912
verification connector only 03497-67913		

as it checks handshaking on the actuator assembly. The information gained by running either of these verification checks will often be a great aid in troubleshooting the assembly.

4-7. Operational Verification Checks Using the Verification Connector

4-8. The following paragraphs describe operational verification procedures for the 44428A assembly using the -hp- Model 03497-67908 Verification Connector. The discussion is written for a -hp- Model 85 computer and its software. There are, however, several other -hp- computers, as indicated in Table 4-2, capable of performing the verification checks with the 03497-67908 Verification Connector. Whichever computer you are

Table 4-1. Recommended Test Equipment

Instrument	Critical Specifications	Recommended Model	Use
3497A Data Acquisition Control Unit (with Front panel)	NO substitutions	-hp- 3497A	P,T
Controller* **	HP-IB compatible	-hp- 85F	P
Voltmeter	HP-IB compatible	-hp- 3456A	P,T
Verification connector (with -hp- 85 software)	**	-hp-03497-67909	P
HP-IB cable		-hp- 10631A	P
Extender assembly		-hp-03497-67913	P,T
Logic Probe		-hp- 545A	T
<p>* -hp- 85F includes: -hp- 85 A, 82936A ROM Drawer, 00085-15003 I/O ROM, and 82937A HP-IB interface. -hp- 85F option 001 exchanges the 82939A Serial Interface for the HP-IB interface.</p> <p>** Controllers other than the -hp- 85 may be used. Refer to Table 4-2 for a list of other -hp- controllers and verification software.</p>			

using, simply follow the instructions given on the computer display.

4-9. Procedure

a. Connect the HP-IB Interface card between the 3497A and one of the 85A's rear panel I/O slots. Also, if the 3456A is to be the DVM used during the test, it should be connected to the same HP-IB line.

b. Turn OFF the 3497A and remove the terminal card from the actuator assembly to be tested.

c. Insert the Verification Connector Card (03497-67908) in place of the removed terminal card according to the instructions on the card and the drawing in Figure 4-1. Use the digital end of the Verification Connector. Follow the drawing closely to assure that the Timer, Channel Closed, BBM Synch, and voltmeter cable are correctly connected.

d. Turn ON the 85F, 3497A, and 3456A (if used).

e. Insert the verification Tape Cartridge into the 85F's tape transport and type the following:

LOAD "CRDVER"

then press:

END LINE

after the program is loaded, press:

RUN

f. Read the instructions given on the CRT display and press 'CONT'.

g. The Menu of the program is given along with description of the Special Function Keys used by the program. Figure 4-2 defines the operation of these keys. To test the 44428A Actuator assembly press K2.

h. If any failures are detected, the computer will indicate the nature of the failure and which relay failed.

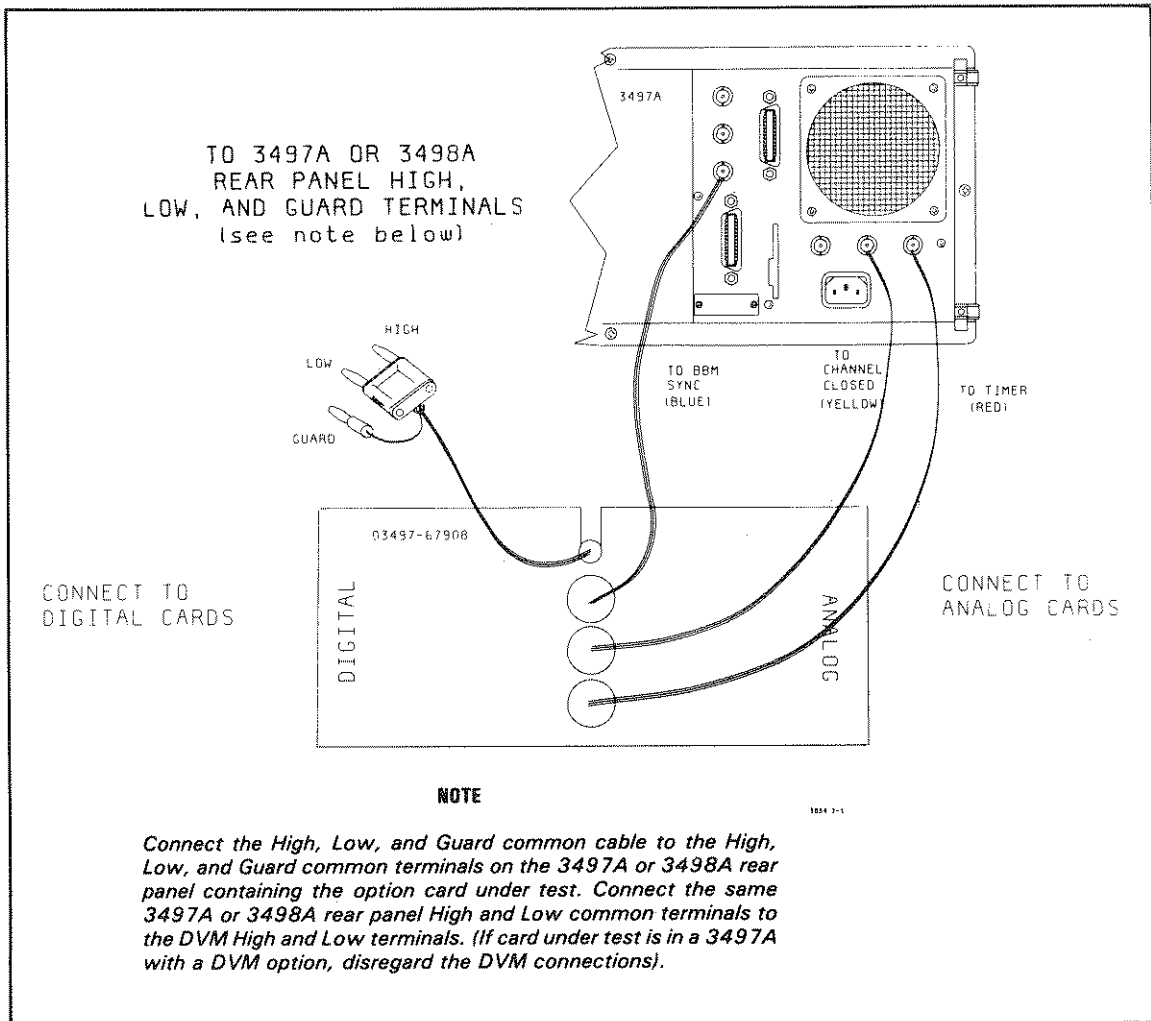

Figure 4-1. Verification Connector

k1 - REED RELAY: Pressing this key enters the 44421A/44422A Reed Relay Verification segment and yields the following:

Enter address of the two reed relay decades (Decade A, Decade B)

Response: enter in the decade addresses of Decades A and B separated by a comma and press CONTINUE. Analog addresses range from 0 to 99 in the 3497A mainframe and start at channel 100 for the first 3498A Extender with each Extender capable of using 200 analog channels. For example, if an analog assembly makes use of channels 0 to 19, Decade A address starts at 0 and Decade B address starts at 10. The entered response would be 0,10.

k2 - ACTUATOR: Pressing this key enters the Actuator/Digital Output Verification test and yield the following:

Enter the slot# of the digital card to be tested (0-4, 10-89).

Response: enter in one of the valid slot numbers that contains the digital card being tested and press CONTINUE. Slots 5 to 9 are used by the 3497A mainframe and cannot be accessed. The first 3498A Extender begins with slot 10.

k3 - DIG INPUT: Pressing this key enters the Digital Input/Interrupt Verification test and yields the following:

Enter the slot# of the digital card to be tested (0-4, 10-89).

Response: enter in one of the valid slot numbers that contains the digital card being tested and press CONTINUE. Slots 5 to 9 are used by the 3497A mainframe and cannot be accessed. The first 3498A Extender begins with slot 10.

k4 - STOP: Pressing this key will terminate the program when in the Menu mode, but will immediately return you to the Menu mode during the testing of an assembly, except when data is to be input.

k8 - CHANGE: Pressing this key allows you to change the HP-IB address of the Scanner and DVM. Enter in the new Scanner address and press END LINE. Enter in the new DVM address and press END LINE.

NOTE

Holding the computer's shift key down while pressing k1, k2, or k3 will permit you to select the number of passes or iterations for each test. This is a good tool for detecting intermittent errors.

Figure 4-2. CRDVER Key Operations.

4-10. Operational Verification Checks Using a Resistor Network

4-11. The following paragraphs describe an operational verification procedure that uses a resistor network that you wire on the terminal card. Resistors with values from ten ohms to 160 ohms in steps of ten ohms (16 required) and resistors with values from 1K ohm to 16K ohm in steps of 1K ohm (16 required) are used. Refer to Table 4-3. If possible, the resistors should have a 1% tolerance and actual values of resistance as close as possible to the nominal step values, i.e., 10, 20, 30, 160 ohms.

4-12. Terminal Card Wiring

a. Turn OFF the 3497A and remove the actuator terminal card.

b. Remove the terminal card cover.

c. Referring to Figure 4-3, wire the terminal card as shown. Use short pieces of insulated wire and the resistors.

Table 4-3. Resistor Values

Value	-hp- Part Number	Value	-hp- Part Number
10Ω	0757-0346	1K Ω	0757-0280
20Ω	0757-0384	2K Ω	0757-0283
30Ω	0757-0388	3K Ω	0757-0273
40Ω	0698-3262	4K Ω	0698-3558
50Ω	0757-0277	5K Ω	0698-3279
60Ω	0698-4391	6K Ω	0698-3497
70Ω	0698-4391	7K Ω	0698-4470
80Ω	0698-4396	8K Ω	0698-4473
90Ω	0757-0400	9K Ω	0757-0442
100Ω	0757-0401	10K Ω	0757-0442
110Ω	0757-0402	11K Ω	0757-0443
120Ω	0757-0403	12K Ω	0757-0444
130Ω	0757-0404	13K Ω	0757-0445
140Ω	0698-4412	14K Ω	0698-4479
150Ω	0757-0286	15K Ω	0757-0446
160Ω	0757-0405	16K Ω	0757-0447

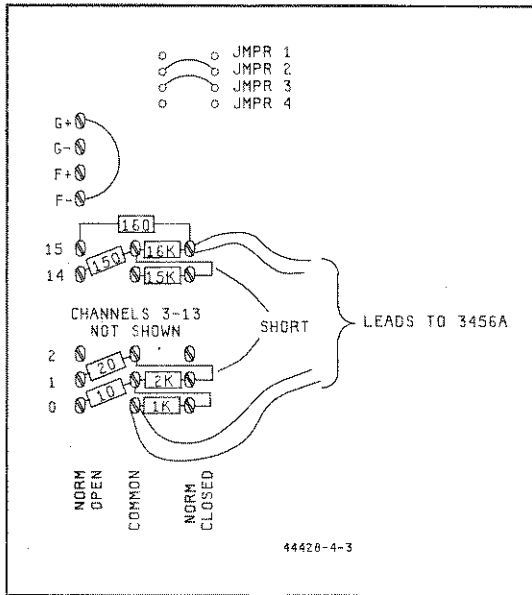

Figure 4-3. Wiring the Terminal Block

d. Connect the lead wires to enable a 4-wire ohms

e. Referring to Figure 4-3, wire the Gate and Flag Handshake terminals and install jumpers J2 and J3.

f. Reassemble the terminal card and connect to the actuator assembly.

4-13. Procedure

4-14. Load the program given in Figure 4-4 into the -hp- Model 85F computer and press the RUN key. Follow all instructions given on the display.

4-15. Testing Relay Contact Resistance

4-16. The following procedure may be used to performance check the contact resistance specification for the actuator assembly. Contact resistance is specified as the resistance between terminal board contacts, i.e., the sum of the resistances from the terminal contact to the relay, the relay contacts, and back to the terminal card. This test should be performed for each individual relay. This ensures that only the contact resistance is measured and thermal offsets are canceled.

a. Remove all cables, etc. from the actuator terminal card.

b. Connect the wires as shown in Figure 4-5 to one relay. Set the 3456A for a 4-wire, offset compensated ohms measurement.

c. Verify that the measured resistance is below 400 milliohms (.4 ohms).

```

10 CLEAR @ DISP "ENTER SLOT NUM
BER" @ INPUT S
20 Z=0
30 CLEAR @ DISP "***** ACTUATOR
TEST *****"
40 DISP @ DISP "SLOT NUMBER =";
S
50 CLEAR 723 @ OUTPUT 723 ;"F4R
RT3"
60 CLEAR 709 @ OUTPUT 709 ;"DR"
;S
70 ; BEGIN NORMALLY CLOSED TEST
80 DISP @ DISP "***** N.O. CONT
ACTS CHECK *****"
90 GOSUB 310
100 IF R<100000 THEN GOTO 120
110 DISP @ DISP "TEST FIXTURE NO
T IN PLACE!" @ BEEP @ GOTO 2
90
120 IF R>6 THEN GOSUB 350
130 IF Z=1 THEN 290
140 DISP @ DISP "NORMALLY CLOSED
CHECKS PASSED" @ Z=0
150 DISP @ DISP "***** N.O. CONT
ACTS CHECK *****"
160 DISP @ DISP "RELAY RESISTANC
E RELAY NUMBER"
170 FOR I=0 TO 15
180 P=2^I
190 IF P=32768 THEN P=-P
200 OUTPUT 709 ;"DW",S,"",",DT0#(
P)
210 GOSUB 310
220 IF R>9 THEN 260
230 DISP @ DISP "RELAY DEAD",I @
Z=1 @ GOTO 260
240 IF INT(R/10)=I+1 THEN 260
250 GOSUB 350
260 DISP R/10,I+1 @ WAIT 500 @ H
EXT I
270 IF Z=1 THEN 290
280 DISP @ DISP "NORMALLY OPEN C
HECKS PASSED"
290 DISP @ DISP "***** END OF TE
ST *****"
300 END
310 ! REED RELAY SUBROUTINE
320 TRIGGER 723
330 ENTER 723 ; R
340 RETURN
350 ! CHECK CHANNEL SUBROUTINE
360 X=R
370 FOR J=0 TO 15
380 O=2^J
390 IF O=32768 THEN O=-O
400 OUTPUT 709 ;"DW",S,"",",DT0#(
O) @ WAIT 200
410 GOSUB 320
420 DISP R,X @ GOTO 440
430 IF INT(R/1000)=INT(X/1000) T
HEN GOTO 470
440 IF INT(R/10)=INT(X/10) THEN
GOTO 480
450 NEXT J
460 RETURN
470 DISP @ DISP "FAILED NORMALLY
CLOSED TEST",J @ Z=1 @ GOTO
450
480 DISP "ILLEGAL MULTICLOSURE",
J @ Z=1 @ GOTO 450
490 STOP

```

Figure 4-4. Actuator/Digital Output Test Program

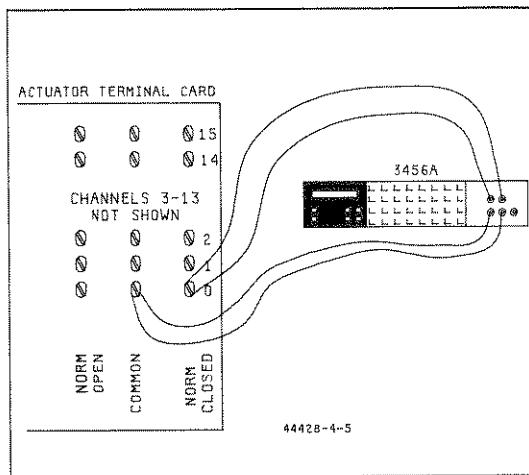

Figure 4-5. Relay Contact Resistance Test

d. Check all of the Normally closed contacts and then execute the command:

DC n,17777

to close all relays. Then perform the checks on the Normally Open contacts.

4-17. Testing Thermal Offset

4-18. Thermal Offset is the voltage generated by the relay contacts themselves and is a function of the heating of the relay coil. To perform the test, the assembly must remain in the 3497A or 3498A mainframe. The mainframe must be turned on for a minimum of hour before performing the tests. The test should be performed on each individual relay.

4-19. Procedure

- a. Remove all cables from the actuator terminal card.
- b. Connect a voltmeter between the normally closed and common terminals on the terminal card.
- c. Check for a voltage of less than 20 μ volts.
- d. Repeat the test for each relay testing both normally closed and normally open contacts.

ADJUSTMENTS

SECTION V

5-1. INTRODUCTION

5-2. There are no adjustments/calibration to be made on the -hp- Model 44428A Actuator/Digital Output assembly. Refer to Section IV Performance Tests for operational verification procedures after repairs have been made.

REPLACEABLE PARTS

SECTION VI

6-1. INTRODUCTION

6-2. This section contains information for ordering replacement parts. Table 6-3 lists parts in alphanumeric order of their reference designators and indicates the description, -hp- part number of each part, together with any applicable notes, and provides the following:

- a. Total quantity used in the instrument (Qty column). The total quantity of a part is given the first time the part number appears.
- b. Description of the part. (See list of abbreviations in Table 6-1.)
- c. Typical manufacturer of the part is a five-digit code. (See Table 6-2 for a list of manufacturers.)
- d. Manufacturer's part number.

6-3. Miscellaneous parts are listed in Table 6-3 following their respective assemblies. General miscellaneous parts are listed at the conclusion of Table 6-3.

6-4. ORDERING INFORMATION

6-5. To obtain replacement parts, address order or inquiry to your local Hewlett-Packard Sales and Service Office. Identify parts by their Hewlett-Packard part

number. Include complete instrument and serial number.

6-6. NON-LISTED PARTS

6-7. To obtain a part that is not listed, include:

- a. instrument model number
- b. instrument serial number
- c. description of the part
- d. function and location of the part

6-8. PARTS CHANGES

6-9. Components which have been changed are so marked by one of three symbols; i.e., Δ , Δ with a letter subscript, e.g., Δ_a , or a Δ with a number subscript, e.g., Δ_{10} . A Δ with no subscript indicates the component listed is the preferred replacement for an earlier component. A Δ with a letter subscript indicates a change which is explained in a note at the bottom of the page. A Δ with a number subscript indicates the related change is discussed in backdating (Section VII). The number of the subscript indicates the change in backdating which should be referred to.

Table 6-1. List of Abbreviations.

ABBREVIATIONS			
Ag	silver	Hz	hertz (cycle/s per second)
Al	aluminum	ID	inside diameter
A	ampere(s)	imp	impregnated
Au	gold	incd	incandescent
C	capacitor	ins	insulation(s)
cer	ceramic	k Ω	kilohm(s) = 10^3 ohms
coef	coefficient	kHz	kilohertz = 10^3 hertz
com	common	L	inductor
comp	composition	lin	linear taper
conn	connection	log	logarithmic taper
dep	deposited	mA	milliampere(s) = 10^{-3} ampere(s)
DPDT	double-pole double-throw	MHZ	megahertz = 10^6 hertz
DPST	double-pole single-throw	M Ω	megohm(s) = 10^6 ohms
elect	electrolytic	met film	metal film
encap	encapsulated	mfr	manufacturer
F	farad(s)	ms	millisecond
FET	field effect transistor	mtg	mounting
fxd	fixed	mV	millivolt(s) = 10^{-3} volts
		μ F	microfarad(s)
GaAs	gallium arsenide	μ s	microsecond(s)
GHz	gigahertz = 10^9 hertz	μ V	microvolt(s) = 10^{-6} volts
gd	guard(ed)	mv	millivolt(s) Mylar®
Ge	germanium	nA	nanoampere(s) = 10^{-9} ampere(s)
gnd	ground(ed)	NC	normally closed
H	henry(ies)	Ne	neon
Hg	mercury	NO	normally open
		NPO	negative positive zero (zero temperature coefficient)
		ns	nanosecond(s) = 10^{-9} seconds
		nr	not separately replaceable
		Ω	ohm(s)
		obd	order by description
		OD	outside diameter
		p	peak
		pA	picoampere(s)
		pc	printed circuit
		pF	picofarad(s) = 10^{-12} farads
		piv	peak inverse voltage
		p/o	part of
		pos	position(s)
		poly	polystyrene
		pot	potentiometer
		p-p	peak-to-peak
		ppm	parts per million
		prec	precision (temperature coefficient, long term stability and/or tolerance)
		R	resistor
		Rh	rhodium
		rms	root-mean-square
		rot	rotary
		Se	selenium
		sect	section(s)
		Si	silicon
		sl	slide
		SPDT	single-pole double-throw
		SPST	single-pole single-throw
		Ta	tantalum
		TC	temperature coefficient
		TiO ₂	titanium dioxide
		tog	toggle
		tol	tolerance
		trim	trimmer
		TSTR	transistor
		V	volt(s)
		vacw	alternating current working voltage
		var	variable
		vdw	direct current working voltage
		W	watt(s)
		w/	with
		wiv	working inverse voltage
		w/o	without
		ww	wirewound
		*	optimum value selected at factory, average value shown (part may be omitted)
		**	no standard type number assigned selected or special type
		®	Dupont de Nemours
DESIGNATORS			
A	assembly	FL	filter
B	motor	HR	heater
BT	battery	IC	integrated circuit
C	capacitor	J	jack
CR	diode or thyristor	K	relay
DL	delay line	L	inductor
DS	lamp	M	meter
E	misc electronic part	MIP	mechanical part
F	fuse	P	plug
		Q	transistor
		QCR	transistor-diode
		R(p)	resistor(pack)
		RT	thermistor
		S	switch
		T	transformer
		TB	terminal board
		TC	thermocouple
		TP	test point
		TS	terminal strip
		U	microcircuit
		V	vacuum tube, neon bulb, photocell, etc.
		W	wire
		X	socket
		XDS	lampholder
		XF	fuseholder
		Y	crystal
		Z	network

Table 6-2. Code List of Manufacturers.

Mfr No.	Manufacturer Name	Address
00000	Any Satisfactory Supplier	
01121	Allen-Bradley Co.	Milwaukee, WI 53204
01295	Texas Instr. Inc. Semicond Compnt Div.	Dallas, TX 75222
04713	Motorola Semiconductor Products	Phoenix, AZ 85062
13606	Sprague Elect. Co. Semiconductor Div.	Concord, NH 03301
24546	Corning Glass Works (Bradford)	Bradford, PA 16701
27014	National Semiconductor Corp.	Santa Clara, CA 95051
28480	Hewlett-Packard Co. Corporate Hq.	Palo Alto, CA 94304
56289	Sprague Electric Co.	North Adams, MA 01247

Table 6-3. Replaceable Parts

Reference Designation	HP Part Number	C D	Qty	Description	Mfr Code	Mfr Part Number
A14	03497-66514	0	1	PC ASSEMBLY-RELAY BOARD	28480	03497-66514
A14C1	0180-0309	4	5	CAPACITOR-FXD 4.7UF+-20% 10VDC TA	56289	150D475X0010A2
A14C2	0180-0309	4		CAPACITOR-FXD 4.7UF+-20% 10VDC TA	56289	150D475X0010A2
A14C3	0180-0309	4		CAPACITOR-FXD 4.7UF+-20% 10VDC TA	56289	150D475X0010A2
A14C4	0180-0309	4		CAPACITOR-FXD 4.7UF+-20% 10VDC TA	56289	150D475X0010A2
A14C5	0180-0309	4		CAPACITOR-FXD 4.7UF+-20% 10VDC TA	56289	150D475X0010A2
A14C6	0160-3847	9	2	CAPACITOR-FXD .01UF +100-0% 50VDC CER	28480	0160-3847
A14C7	0160-3847	9		CAPACITOR-FXD .01UF +100-0% 50VDC CER	28480	0160-3847
A14CR1	1902-0244	9	1	DIODE-ZNR 30V 5% PD=1W IR=5UA	28480	1902-0244
A14CR2	1901-0050	3	1	DIODE-SWITCHING 80V 200MA 2NS D0-35	28480	1901-0050
A14J1	1251-6373	6	1	CONNECTOR 6-PIN M POST TYPE	28480	1251-6373
A14J2	1251-4647	3	1	CONNECTOR 3-PIN M POST TYPE	28480	1251-4647
A14K0	0490-1229	6	16	RELAY-REED 1C 2A 500VAC 10VDC-COIL 100VA	28480	0490-1229
A14K1	0490-1229	6		RELAY-REED 1C 2A 500VAC 10VDC-COIL 100VA	28480	0490-1229
A14K2	0490-1229	6		RELAY-REED 1C 2A 500VAC 10VDC-COIL 100VA	28480	0490-1229
A14K3	0490-1229	6		RELAY-REED 1C 2A 500VAC 10VDC-COIL 100VA	28480	0490-1229
A14K4	0490-1229	6		RELAY-REED 1C 2A 500VAC 10VDC-COIL 100VA	28480	0490-1229
A14K5	0490-1229	6		RELAY-REED 1C 2A 500VAC 10VDC-COIL 100VA	28480	0490-1229
A14K6	0490-1229	6		RELAY-REED 1C 2A 500VAC 10VDC-COIL 100VA	28480	0490-1229
A14K7	0490-1229	6		RELAY-REED 1C 2A 500VAC 10VDC-COIL 100VA	28480	0490-1229
A14K8	0490-1229	6		RELAY-REED 1C 2A 500VAC 10VDC-COIL 100VA	28480	0490-1229
A14K9	0490-1229	6		RELAY-REED 1C 2A 500VAC 10VDC-COIL 100VA	28480	0490-1229
A14K10	0490-1229	6		RELAY-REED 1C 2A 500VAC 10VDC-COIL 100VA	28480	0490-1229
A14K11	0490-1229	6		RELAY-REED 1C 2A 500VAC 10VDC-COIL 100VA	28480	0490-1229
A14K12	0490-1229	6		RELAY-REED 1C 2A 500VAC 10VDC-COIL 100VA	28480	0490-1229
A14K13	0490-1229	6		RELAY-REED 1C 2A 500VAC 10VDC-COIL 100VA	28480	0490-1229
A14K14	0490-1229	6		RELAY-REED 1C 2A 500VAC 10VDC-COIL 100VA	28480	0490-1229
A14K15	0490-1229	6		RELAY-REED 1C 2A 500VAC 10VDC-COIL 100VA	28480	0490-1229
A14P1A	1258-0141	8	3	JUMPER-REM	28480	1258-0141
A14P1B	1258-0141	8		JUMPER-REM	28480	1258-0141
A14P2	1258-0141	8		JUMPER-REM	28480	1258-0141
A14Q1	1853-0036	2	1	TRANSISTOR PNP SI PD=310MW FT=250MHZ	28480	1853-0036
A14R1	0683-1635	7	1	RESISTOR 16K 5% .25W FC TC=-400/+800	01121	CB1635
A14R2	0698-4442	9	1	RESISTOR 237 1% .125W F TC=0+-100	24546	C4-1/8-T0-237R-F
A14R3	0698-4430	7	1	RESISTOR 1.91K 1% .125W F TC=0+-100	24546	C4-1/8-T0-1911-F
A14R5	0683-4705	8	3	RESISTOR 47 5% .25W FC TC=-400/+500	01121	CB4705
A14R6	0683-4705	8		RESISTOR 47 5% .25W FC TC=-400/+500	01121	CB4705
A14R7	0683-4705	8		RESISTOR 47 5% .25W FC TC=-400/+500	01121	CB4705
A14R21	0757-0438	3	1	RESISTOR 5.11K 1% .125W F TC=0+-100	24546	C4-1/8-T0-5111-F
A14R22	0683-3015	1	1	RESISTOR 300 5% .25W FC TC=-400/+600	01121	CB3015
A14R23	0683-1035	1	1	RESISTOR 10K 5% .25W FC TC=-400/+700	01121	CB1035
A14R24	0683-3015	7	1	RESISTOR 300 5% .5W CC TC=0+-529	01121	EB3015
A14U1	1820-1759	9	3	IC BFR TTL LS NON-INV OCTL	27814	DM81LS97N
A14U2	1820-1208	3	1	IC GATE TTL LS OR QUAD 2-INP	01295	SN74LS32N
A14U3	1820-1281	2	1	IC DCDR TTL LS 2-TO-4-LINE DUAL 2-INP	01295	SN74LS139N
A14U4	1820-1423	4	1	IC MV TTL LS MONOSTBL RETRIG DUAL	01295	SN74LS123N
A14U5	1820-1112	8	1	IC FF TTL LS D-TYPE POS-EDGE-TRIG	01295	SN74LS74AN
A14U6	1820-1199	1	1	IC INV TTL LS HEX 1-INP	01295	SN74LS04N
A14U7	1820-1759	9		IC BFR TTL LS NON-INV OCTL	27814	DM81LS97N
A14U8	1820-1759	9		IC BFR TTL LS NON-INV OCTL	27814	DM81LS97N
A14U9	1820-1730	6	2	IC FF TTL LS D-TYPE POS-EDGE-TRIG COM	01295	SN74LS273N
A14U10	1820-1730	6		IC FF TTL LS D-TYPE POS-EDGE-TRIG COM	01295	SN74LS273N
A14U11	1858-0047	5	3	TRANSISTOR ARRAY 16-PIN PLSTC DIP	13606	ULN-2003A
A14U12	1858-0047	5		TRANSISTOR ARRAY 16-PIN PLSTC DIP	13606	ULN-2003A
A14U13	1858-0047	5		TRANSISTOR ARRAY 16-PIN PLSTC DIP	13606	ULN-2003A
A14U14	1990-0429	7	1	OPTO-ISOLATOR LED-IC GATE IF=10MA-MAX	28480	1990-0429
A14U15	1990-0486	8	1	OPTO-ISOLATOR LED-PXSTR IF=80MA-MAX	04713	4N25
A14VR1	0837-0196	8	1	MOV 430 VRMS 1.5J	28480	0837-0196
A15	03497-66515	1	1	PC ASSEMBLY-TERMINAL CARD	28480	03497-66515
A15CR1	1901-0025	2	1	DIODE-GEN PRP 100V 200MA D0-7	28480	1901-0025
A15R1	0699-0064	7	1	RESISTOR 50 .1% .5W F TC=0+-25	28480	0699-0064
				MISCELLANEOUS PARTS		
A15Z3	0360-1993	6	1	BARRIER-BLK 10 ANG	28480	0360-1993
	0360-1994	7	1	BARRIER-BLK 3 ANG	28480	0360-1994
	1200-0473	8	1	SOCKET-IC 16-CONT DIP DIP-SLDR	28480	1200-0473
	1251-3535	6	1	CONNECTOR 16-PIN M RECTANGULAR	28480	1251-3535
	1251-5944	5	1	CONNECTOR-PC EDGE 36-CONT/ROW 2-ROWS	28480	1251-5944

See introduction to this section for ordering information
 *Indicates factory selected value

Table 6-3. Replaceable Parts (Cont'd)

Reference Designation	HP Part Number	C D	Qty	Description	Mfr Code	Mfr Part Number
				MECHANICAL PARTS LIST		
	0515-0211	8	2	SCREW-MACH M3 X 0.5 6MM-LG PAN-HD	00000	ORDER BY DESCRIPTION
	03497-64100	6	1	TERMINAL BOX KIT INCLUDES THE FOLLOWING	28480	03497-64100
MP1	5041-3044	1	1	HANDLE	28480	5041-3044
MP2	0515-0269	6	4	SCREW-PH M3.0X25	00000	ORDER BY DESCRIPTION
MP3	5041-3045	2	1	TERMINAL BOX COVER	28480	5041-3045
MP4	0905-0375	2	4	"O" RING	28480	0905-0375
MP5	5041-3036	1	1	"C" RING	28480	5041-3036
MP6	5041-3043	0	1	BAR LATCH	28480	5041-3043
MP7	5041-3046	3	1	TERMINAL BOX	28480	5041-3046
MP8	7121-0367	7	1	LABEL 44428A	28480	7121-0367
MP9	7121-1786	6	1	LABEL	28480	7121-1786
MP10	7121-0341	7	1	LABEL-BLACK H/P	28480	7121-0341

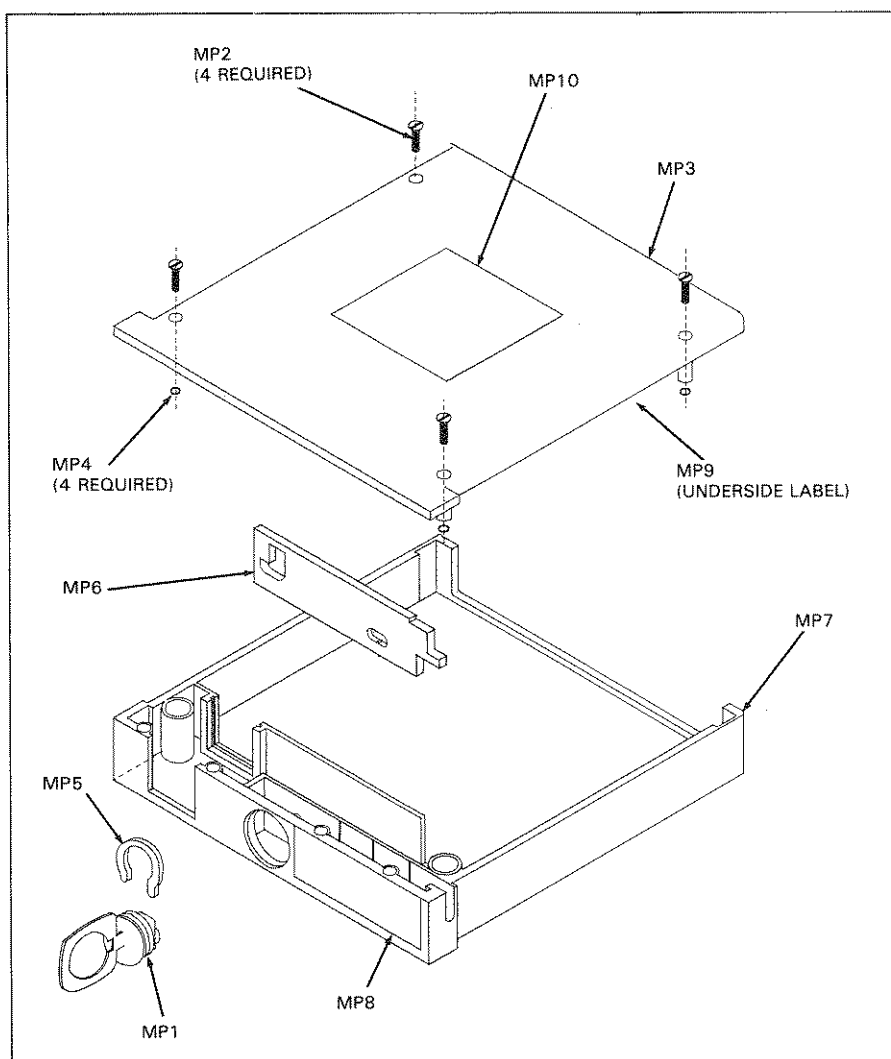

Figure 6-1. Mechanical Parts

See introduction to this section for ordering information
 *Indicates factory selected value

MANUAL CHANGES

SECTION VII

7-1. INTRODUCTION

7-2. This section normally contains information for adapting this manual to assemblies with a serial number prior to the one indicated on the title page. Since this manual does apply to all -hp- Model 44428A Actuator/Digital Output assemblies, no change information is given.

SERVICE

SECTION VIII

8-1. INTRODUCTION

8-2. This section contains theory of operation, schematics, component locators, and troubleshooting procedures to aid in servicing the -hp- Model 44428A Actuator/Digital Output assembly. Also included is a functional block diagram of the assembly.

8-3. SAFETY CONSIDERATIONS

8-4. The 3497A Data Acquisition-Control unit and the associated plug-in option assemblies have been designed in accordance with international safety standards. However, this manual contains information and warnings that must be followed to insure personal safety during operation and maintenance.

WARNING

Maintenance procedures in this section are intended for the use of qualified service trained personnel only. Only qualified service trained personnel are to install, re-configure, or make repairs to this assembly. Use clean handling techniques (antistatic techniques) when inspecting, removing, replacing or re-configuring the assembly. Handle the card by its edges and do not subject the components to static discharge or excessive voltages. To prevent serious personal injury, extreme caution must be exercised when working with optional plug-in cards. Potential shock hazards (voltages up to 170 volts peak) can exist between exposed guard and chassis on both the front (when front panel is open) and the rear of the 3497A/3498A (when safety cover is removed). Disconnect 3497A/3498A power cord, disconnect all input/output lines to/from the mainframe and option cards and make certain that wires to the actuator terminal cards are free of voltage sources prior to handling or inserting or extracting the assembly.

8-5. BLOCK DIAGRAM THEORY OF OPERATION

8-6. Refer to Figure 8-1 for the following block diagram theory of operation. Eight bit input data (relay command data) is received by the Actuator assembly

over the bi-directional data bus D0-D7. This data is accepted by two octal D-type flip-flops (IC's U9 and U10) which drive, via the relay drivers (U11, U12, and U13), relays K0 to K15. Output of the flip-flops is also fed to two tri-state octal buffers (U7,U8) that are used to feed back relay status information when interrogated by the 3497A.

8-7. The Status Read Command (SRn,0) allows the 3497A to interrogate the various option assemblies to determine which type of assembly is in the slot. Internally, the 3497A reads the output code from the identity register to verify the presence of the actuator assembly. A tri-state buffer (U1) is hard-wired for the actuator card code is used for this purpose. Refer to Section III, Operation, paragraph 3-15 for more information on the "SIGNATURE" of the Actuator assembly.

8-8. The optically isolated handshake lines are used to synchronize the transfer of either individual relay outputs or a 16 bit wide digital word (K0-K15). The handshake mode of operation can be selected or disabled with a jumper plug (P2) on the relay circuit board. See Section II, INSTALLATION, for information on configuring the handshake lines.

8-9. The I/O Read, I/O Write, Slot Select, and Address (BA0, BA1) lines from the 3497A are used to synchronize all of the actuator assembly operations. Actuator assembly outputs are accessed via the 03497-66515 Terminal Card. Gate and flag handshake lines are also accessed via the Terminal Card.

8-10. DETAILED THEORY OF OPERATION

8-11. Relay Drivers

8-12. Eight bit (D0-D7) digital input information is supplied from the 3497A/3498A mainframe to octal Flip-Flop ic's U9 and U10. See schematic number 1. Data is clocked into U9 when address line BA0 is low and address line BA1 is high. Similarly, data is clocked into U10 when address lines BA0 and BA1 are high and low, respectively. In either case, the SLOT SELECT and DIG I/O WRITE lines must both be low. Refer to paragraph 8-16 for information on decoder ic U3. Splitting the control of the Flip-Flops allows sixteen relays to be controlled by eight data bus lines.

8-13. The latched output of the Flip-Flops drive ic's U11, U12, and U13 which are high current, internally diode protected, relay drivers. The output of the Flip-Flops also connect to the inputs of tri-state buffer ic's

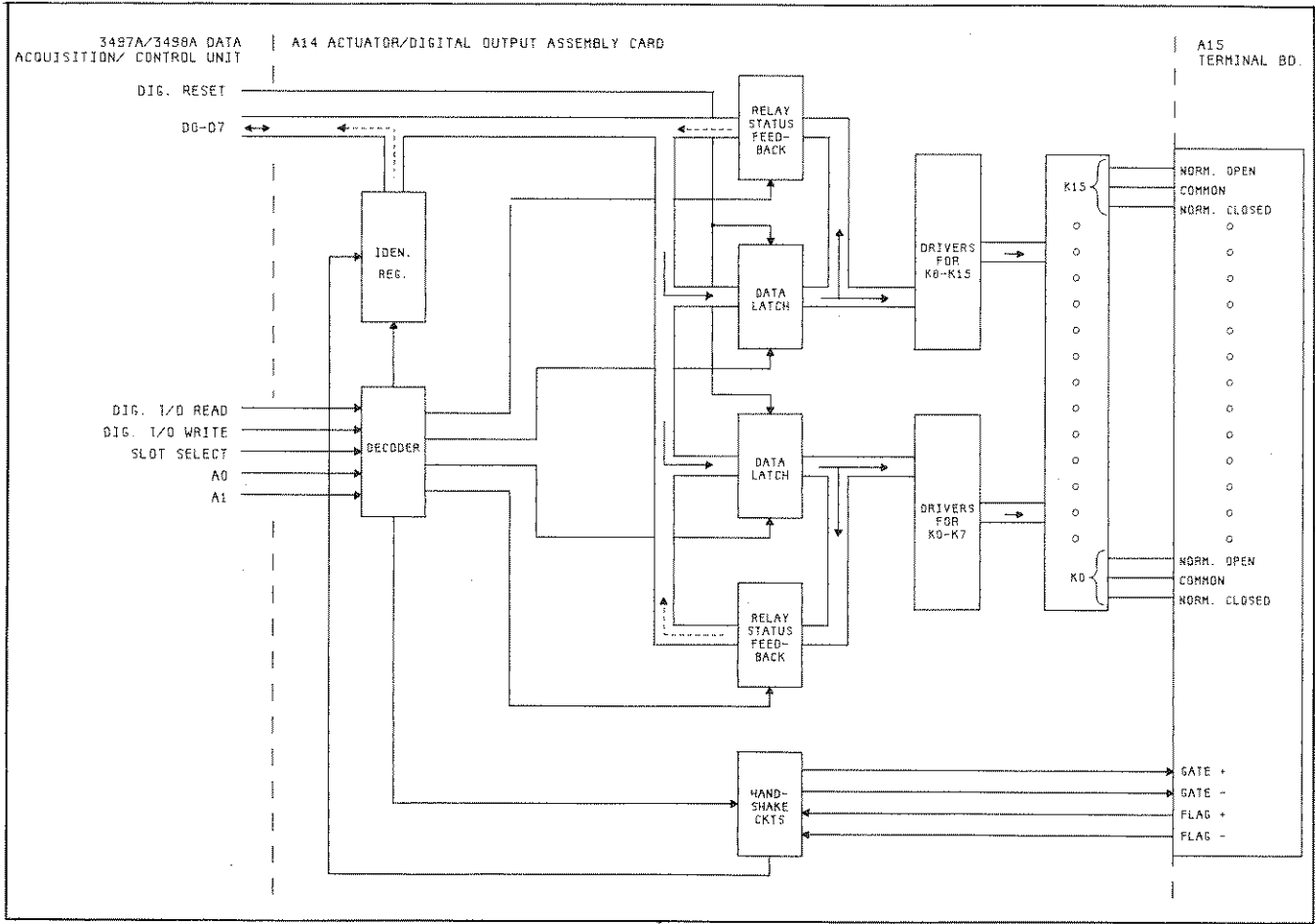

Figure 8-1. Functional Block Diagram

U8 and U7. These buffers provide a means of reading the status of the relays. Buffer U8 is read when address lines BA0 and BA1 are low and high, respectively. Similarly, U7 is read when address line BA0 and BA1 are high and low, respectively. Also, the SLOT SELECT and DIG I/O READ lines must be low. Refer to paragraph 8-16 for more information on decoder ic U3.

8-14. Identity Register and Decoder

8-15. Identity register U1 is a tri-state buffer that, when addressed (address lines BA0 and BA1, SLOT SELECT and DIG I/O READ are all low), outputs an identity word to the mainframe data bus. The identity word as output to the data bus (D7, D6, ... D1, D0) is: 001X0001 (X, bit 4, may be either a 1 or a 0). All bits, except bit 4, are hard-wired. If bit 4 is read as a low, it means that the handshake function is disabled. If the handshake function is enabled and bit 4 is read as a high, the mainframe processor will halt execution of instrument command instructions and will continue to monitor the identity register until bit 4 returns low.

8-16. Decoder ic U3 is a dual 2 line to 4 line decoder ic. Section 1 is gated on when information is to be read

from the actuator assembly to the mainframe. This is accomplished when the DIGITAL I/O READ line and SLOT SELECT lines are both low (input to U2A). Section 2 is gated when information is to be written to the actuator assembly from the mainframe. This occurs when the SLOT SELECT line and the DIGITAL I/O WRITE line are both low (input to U2B). Both halves of U3 have a truth table as shown in Figure 8-2.

8-17. Flag and Gate Handshake

8-18. The Gate signal is generated by monostable multivibrator U4A. The pulse and its complement (U6B) is available at jumper J1A. Transistor Q1 drives

INPUTS			OUTPUTS			
ENABLE	SELECT					
G	BA1	BA0	Y0	Y1	Y2	Y3
H	X	X	H	H	H	H
L	L	L	L	H	H	H
L	L	H	H	L	H	H
L	H	L	H	H	L	H
L	H	H	H	H	H	L

Figure 8-2. U3 Truth Table

optical isolator U15. The outputs of U15 are available as GATE+ and GATE- on the Terminal Card. If necessary, the isolation may be defeated by adding jumpers JMPR1 (use a 10Kohm resistor) and JMPR2 on the Terminal Card. Figure 8-3 illustrates the handshake timing diagram for Gate pulse.

8-19. Flag inputs to the actuator assembly are used to signify that the external circuits or devices have received the data and are ready to receive additional output from the assembly. The input pulse (FLAG+ and FLAG-) is used to activate optical isolator U14. The pulse and its complement (U6A) are available at jumper J1B. U5B is used as a latch to hold the flag status until the mainframe processor reads the identity register. Jumper J2 is used to enable or disable the handshake function.

8-20. TROUBLESHOOTING INFORMATION

8-21. Instrument Preparation. To prepare the -hp-Model 44428A Actuator/Digital output assembly for troubleshooting, perform the following steps:

WARNING

These procedures were designed for use by qualified service trained personnel only. To prevent serious personal injury, extreme caution must be exercised when working with plug-in assemblies. The 3497A/3498A may contain voltages as high as 357 volts within the cabinet enclosures. Use clean handling techniques when servicing this printed circuit board.

- a. Verify that the mainframe line switch is off.
- b. Turn off all other external sources of input power to the 3497A and/or 3498A and remove the safety cover from the rear of the instrument.
- c. Remove all input terminal cards and/or verify that all sources of signal input power are within 40 volts of ground potential.
- d. Unplug the 44428A assembly to be serviced and plug the 03497-67913 Extender Cable in its place. Then plug the actuator assembly onto the extender board.
- e. Connect a logic probe to +5 volts and GND as indicated by designated pins on the printed circuit board.
- f. Turn the mainframe ac line switch to the on position.

8-22. Relay Decoding and Driving Circuits.

8-23. When a malfunctioning relay is suspected, first check the relay with an ohmmeter for an open coil.

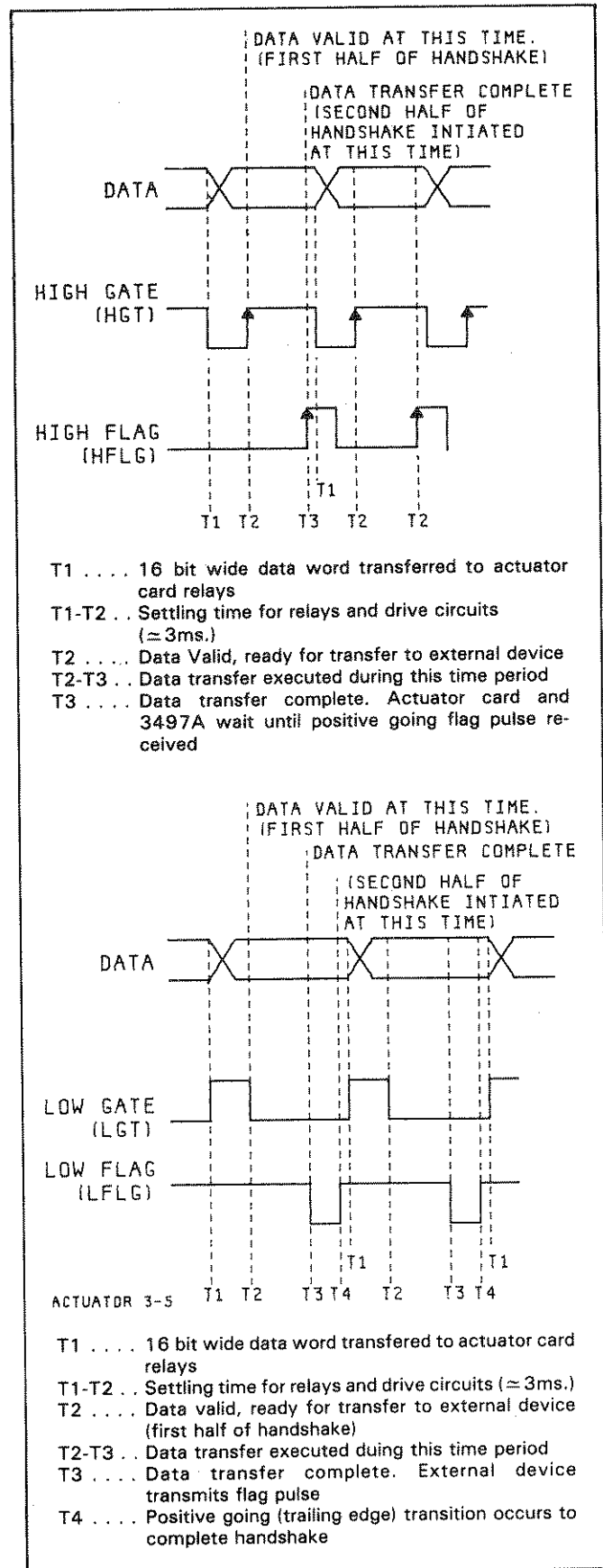

Figure 8-3. Handshake Timing

Then, check for a voltage across the coil when the relay is activated, that is, execute a Digital Close (DC) command for that relay. If the coil is good and the relay energizing voltage is present but there is no continuity in the relay contacts, the relay is bad and should be replaced.

8-24. If the energizing voltage is not present, work back toward U9 or U10 and then to the decoder, U3. Check for logic transitions when the relay is activated. The BASIC language program shown in Figure 8-4 may be used to alternately open and close a selected relay.

```

10 !-hp- 44428A ACTUATOR TEST
20 !-HP- 85 VERSION
30 CLEAR
40 DISP "ENTER SLOT # OF ACTUATOR"
50 INPUT S
60 DISP "ENTER CHANNEL # FOR TEST"
70 INPUT C
80 CLEAR 709 @ WAIT 500
90 DISP "TEST IN PROGRESS"
100 OUTPUT 709; "DC",S,"",C
110 WAIT 100
120 OUTPUT 709; "DO",S,"",C
130 WAIT 100
140 GOTO 100
150 END
    
```

Figure 8-4. Actuator Exercise Program

8-25. Control Logic

8-26. If there is no response from the actuator assembly under any circumstances, then suspect the control logic.

U3 decodes the actuator commands from the main-frame processor. One output from U3 enables identity register U1, pins 1, 19. If this signal is not available to U1, then the processor reacts as though the slot was empty. Run the program in Figure 8-4 while monitoring all inputs and outputs of U1, U2A, U2B, and U3 to detect errors in operation.

8-27. Handshake Logic

8-28. The processor detects that the handshake function has been disabled when it reads Identity Register U1 and finds bit 4 low. If bit 4 is high, then the processor will halt execution of instrument command instructions and will monitor U1 until the handshake has been completed and bit 4 returns low. For this reason, in the following test make certain that jumper J2 is in the OFF position.

8-29. Make the following connections on the Terminal card:

- a. Connect Gate+ to Flag+ and Gate- to Flag-.
- b. Connect a 10Kohm or higher value resistor in place of JMPR1.
- c. Use a short piece of wire to connect JMPR2.

8-30. Verify that the handshake jumper J2 on the relay board is in the OFF position. Run the program in Figure 8-4. Use a logic probe to trace the signal path from U4A, pin 13, through isolator U15 and the Terminal Card, back through isolator U14 and up to U6C, pin 6.

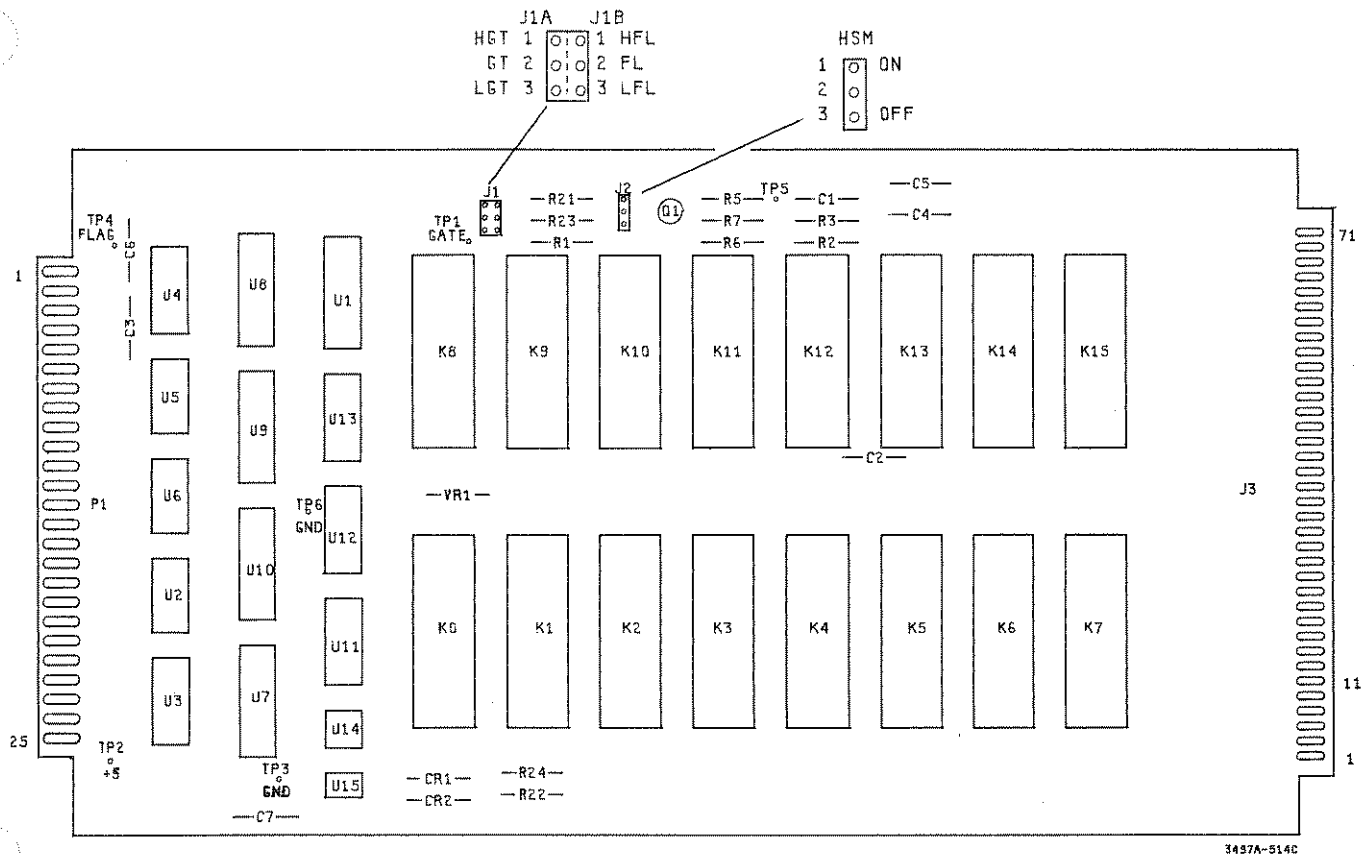

A14
03497-66514

IC	TYPE	+5 V	GND	+5*	GND*
U1	81LS97N	10	20	—	—
U2	74LS32	14	7	—	—
U3	74LS139	16	8	—	—
U4	74LS123N	16	8	—	—
U5	74LS74	14	7	—	—
U6	74LS04	14	7	—	—
U7,U8	81LS97	20	10	—	—
U9,U10	74LS273	20	10	—	—
U11	ULN2003A	—	—	9 VIA R5	6,7,8
U12	ULN2003A	—	—	9 VIA R6	6,7,8
U13	ULN2003A	—	—	9 VIA R7	7,8



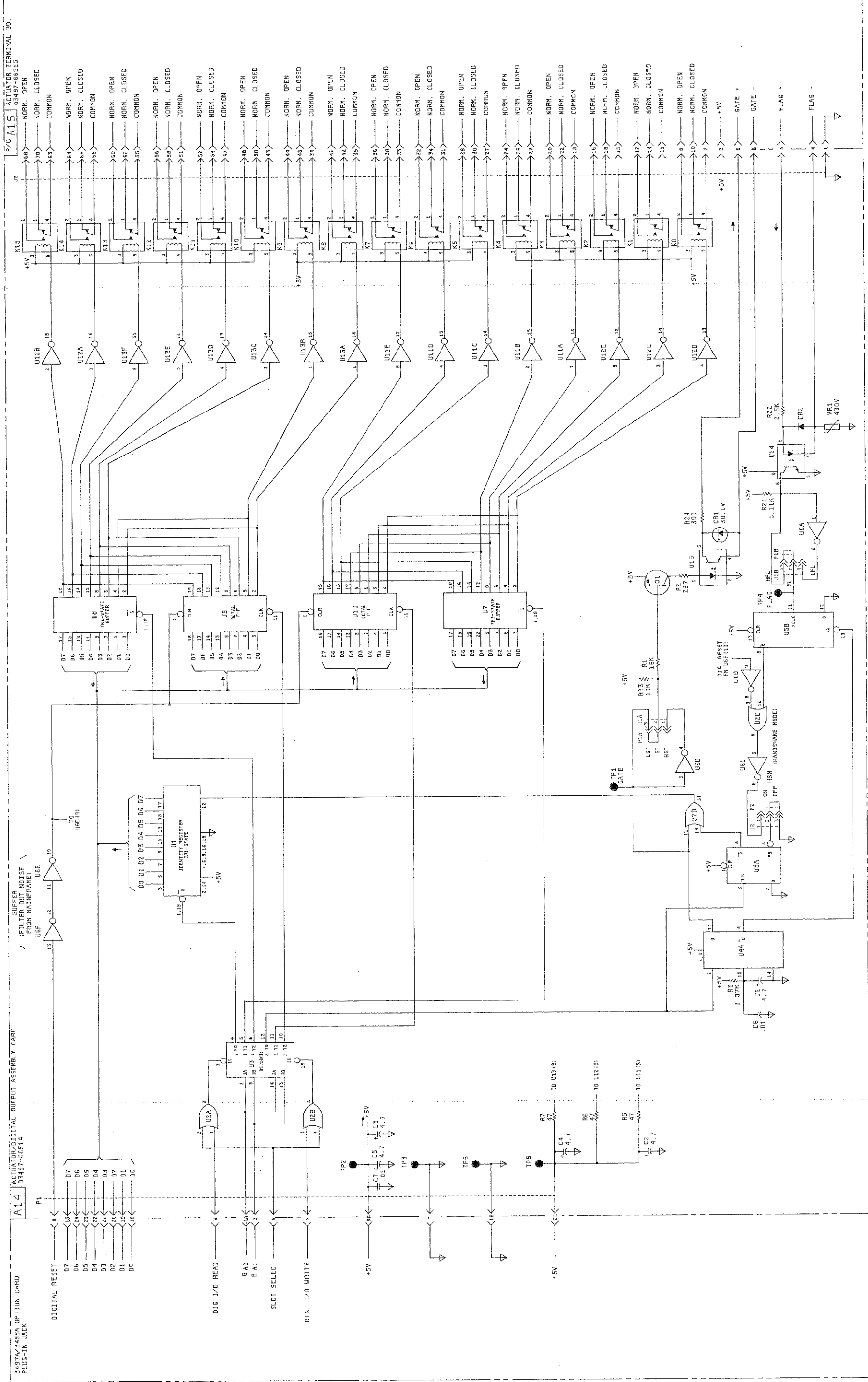
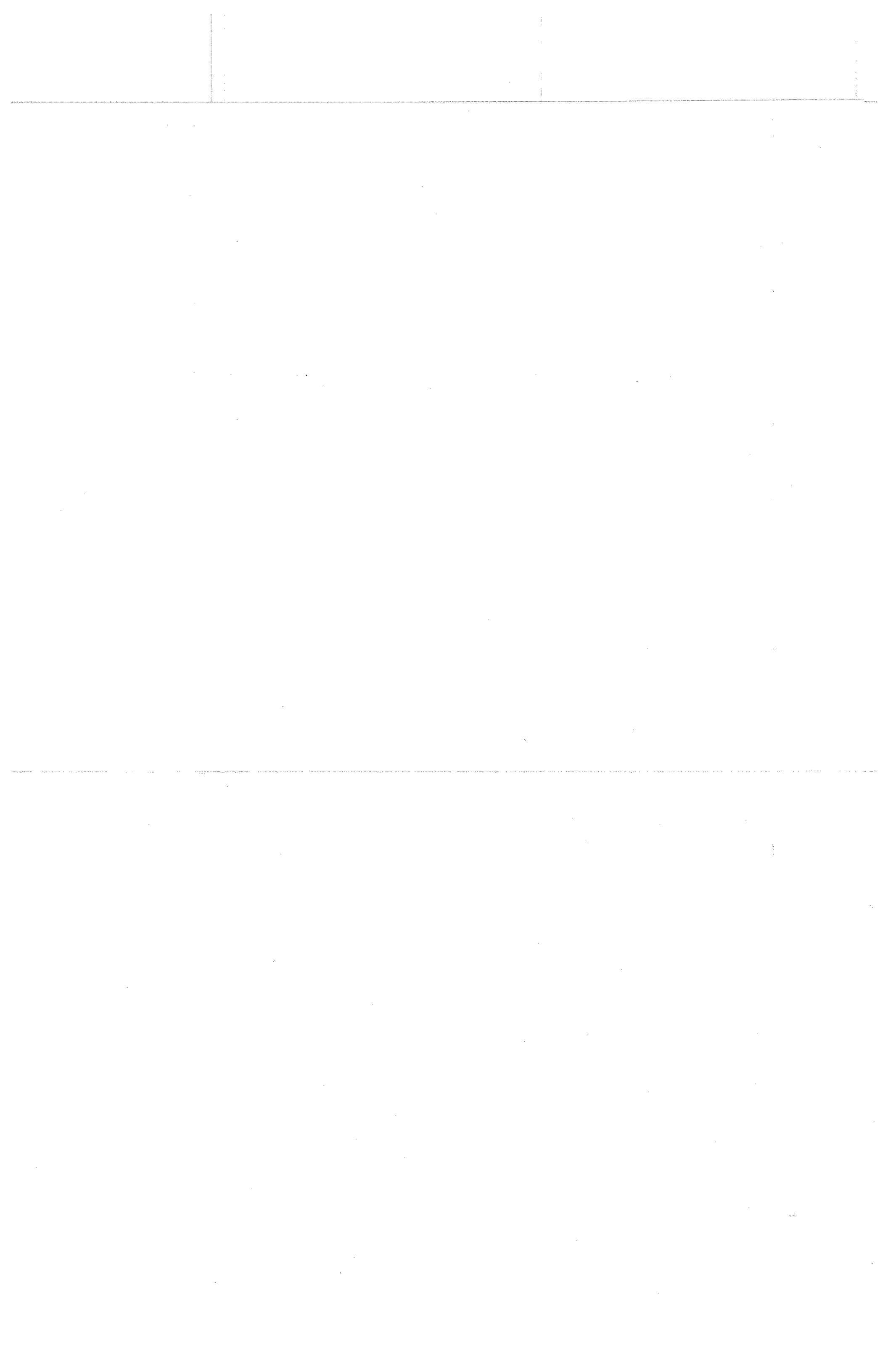
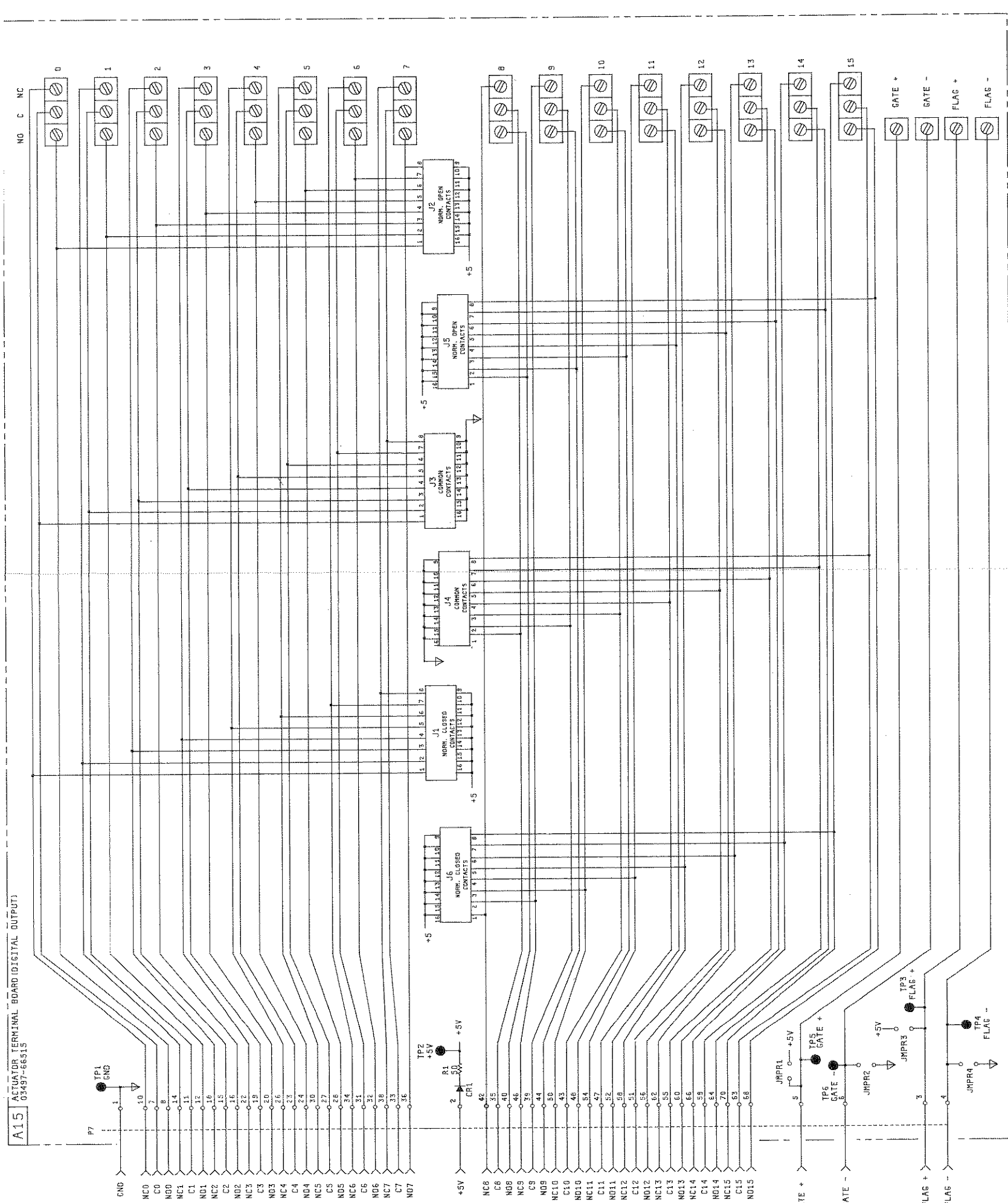

Figure 8-5. Actuator Assembly Card 8-5/8-6





A15 ACTUATOR TERMINAL BOARD (DIGITAL OUTPUT)
03497-66515

3457A-513A

COPYRIGHT 1980 BY HEWLETT-PACKARD COMPANY

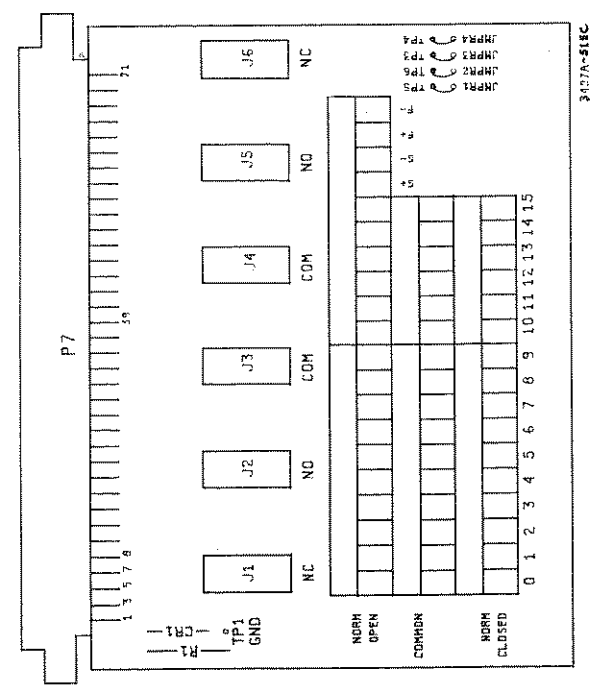

A15
03497-66515

NOTE
JUMPERS 1, 2, 3, 4
NORMALLY NOT PRESENT.
JUMPER 1 IS A 10K
OHM RESISTOR
WHEN USED.

Figure 8-6. Actuator Terminal Card
8-7/8-8

