

OPERATING AND SERVICE MANUAL

6177B

DC POWER SUPPLY

CCB SERIES

MODEL 6177B

HEWLETT  PACKARD



**DC POWER SUPPLY
CCB SERIES
MODEL 6177B**

OPERATING AND SERVICE MANUAL

FOR SERIALS 9C0191 - 0215*

*For Serials Below 9C0191
Refer to Appendix A
Manual Backdating Changes.

*For serials above 9C0215
a Change Page may be in-
cluded.

100 Locust Avenue, Berkeley Heights, New Jersey 07922

MANUAL CHANGES

Model 6177B DC Power Supply
Manual HP Part No. 06177-90002

Make all corrections in the manual according to errata below, then check the following table for your power supply serial number and enter any listed change(s) in the manual.

SERIAL		MAKE CHANGES
Prefix	Number	
9C	0191 - 0275	1
0B	0276 - 0365	1, 2
0B	0338, 0339, 0340, 0343, 0346, 0348, 0354, 0356, 0357, 0364	1, 2, 3
0J	0366 - Up	1, 2, 3
ALL	-	Errata
0J	0426 - 0470	1, 2, 3, 4
0J	0471 - 0580	1 thru 5
1149A	0581 - up	1 thru 6

CHANGE 1:

Table 5-4, Step 1 should read as follows:
Remove CR25 and CR26 from circuit (open). Open the base lead of Q19B. Disconnect the wire at point B (white wire). Refer to Component Location Diagram, Figure 7-2.

CHANGE 2:

The serial number prefix of the instrument has been changed from "9C" to "0B".

In the Replaceable Parts Table, make the following changes:

- Front Panel Binding Post, White: Delete, HP Part No. 1510-0067.
- Meter Bezel: Change to HP Part No. 4040-0414.
- Connector, Test Point, Pin Jack, White: Add, HP Part No. 1251-2440.
- Connector, Test Point, Pin Plug, White: Add, HP Part No. 1251-2441.

In the Replaceable Parts Table and on schematic diagram, make the following changes:

- R5: Change to 5.49k, 1/8W, HP Part No. 0698-3382.
- R10: Change to 5.1k, 1/2W, HP Part No. 0698-3644.
- R9: Change to 270 Ω , 1/2W, HP Part No. 0686-2715.
- Q3, 6: Change to HP Part No. 06177-80001.
- R33: Change to 2.4K, 1/2W, HP Part No. 0686-2425.
- R51: Change to 51 Ω , 1/2W, HP Part No. 0686-5105.
- CR11: Add, HP Part No. 1901-0461.
- Disconnect the cathode of VR13 from TP18 and connect the cathode of CR11 to cathode of VR13.
- Connect anode of CR11 to TP18.

Table 5-4, Step 1 should read as follows:
Remove jumper J1, connected to anode of CR26 (point A). Disconnect wire at point B. Refer to Component Location Diagram, Figure 7-2.

CHANGE 3:

The serial number prefix of the instrument has been change from "0B" to "0J".

In the Replaceable Parts Table and on the schematic diagram, make the following changes:

- R70: Change to 270 Ω , 1/2W, HP Part No. 0686-2715.
- CR25, CR26, CR33: Change to HP Part No. 1901-0642.
- R50: Add, 100 Ω , 1/8W, HP Part No. 0757-0401, connected between +OUT and the junction of CR25 anode, CR26 cathode, and Q19A base.

► In the Replaceable Parts Table, delete Q25 (HP Part No. 1854-0311) from the Main P.C. Board. Add new Q25 (HP Part No. 1854-0250) to the Chassis Electrical. The new electrical connections of the new Q25 have not been changed but the transistor is now mounted on the rear Heat Sink. A boron nitride insulator (HP Part No. 0340-0411) has been installed under Q25 before mounting it on the Heat Sink.

ERRATA:

On Page 5-14, in Part B of Table 5-10, change Step (b) to read: "Output current remains low."

On the schematic diagram, make the following changes:

Change the references next to the integrated circuits in the guard supply and the main error amplifier to read: "Z2 (See Note 11); Z1 (See Note 11)" respectively.

Change the reference next to the jumpers in the meter circuit to read: "Note 9."

Change the positions of the Current Range Switch (S2) to read (from top): "500mA, 50mA, 5mA."

Change the note in the dotted box representing the Input Circuit Board in two places on the schematic to read: "P/O Input P.C. Board (06177-60021)."

Change Note 4 to read: "All components located on main printed circuit board (06177-60022) unless otherwise indicated."

In the Replaceable Parts Table, make the following changes:

- VR6: Change rating to 16.2V, 400mW.
- Shoulder Washer, insulated: Add, qty. 6, HP Part No. 2190-0490.
- Bushing Insulator, collector screws, Q7, Q29, Q30: Change HP Part No. to 0340-0170.
- Indian Bead: Add, HP Part No. 4330-0145. Used to prevent Ferrite bead L1 from contacting case of transistor Q2.
- P.C. Board Guide: Add, HP Part No. 0403-0150.
- Lampholder Base, DS1, DS2: Change to HP Part No. 5040-0305.

CHANGE 4:

In the Replaceable Parts Table, change C33 to 0.01 μ F, 200V, HP Part No. 0160-0161.

CHANGE 5:

In the Replaceable Parts Table make the following changes:

- Q6: Change to HP Part No. 1853-0083.
- R5: Change to 6.2k, 1/8W, \pm 1%, HP Part No. 0698-5087.
- R14: Change to 22k, $\frac{1}{2}$ W, HP Part No. 0686-2235.

CHANGE 6:

The standard colors for this instrument are now mint gray (front and rear panels) and olive gray (for top, bottom, and side surfaces). Option X95 designates use of the former color scheme of light gray and blue gray. Option A85 designates use of a light gray front panel and olive gray for the remaining surfaces. New Part Numbers are shown below:

DESCRIPTION	HP PART NO.		
	STANDARD	OPTION A85	OPTION X95
Front Panel, Complete	06177-60002	←	Refer to Manual Parts List
Front Panel, Top Insert	06177-60006	06177-60003	
Front Panel, Bottom Insert	06177-60004	←	
Heat Sink, Rear Panel	5020-8067	←	
Rear Panel	5000-9461	←	
Cover, Side	5000-8559	←	
Cover, Top	5060-8585	←	
Cover, Bottom	5000-9444	←	
Rack Kit (Assy.)	5060-8764	Not Applicable	
Filler Panel (Assy.)	5060-8530	Not Applicable	

SECTION I GENERAL INFORMATION

1-1 DESCRIPTION

1-2 This supply, is designed for applications requiring a constant current source with a high degree of regulation and stability and very low ripple characteristics. The use of a three-position output RANGE switch and a 10-turn output CURRENT control result in resolution down to 0.5 μ A. Special attention has been given to circuit details so that well regulated performance is maintained down to very low output currents — of the order of 1 μ A.

1-3 A special guard supply, within the unit, provides a voltage which is used to prevent internal leakage currents which would degrade the regulation characteristics. Since the positive output voltage is held equal to the guard voltage, it is also used to drive the front panel voltmeter effectively isolating the voltmeter from the main supply. This prevents the usual output degradation associated with connecting a voltmeter across a constant current supply.

1-4 The supply is completely transistorized (all-silicon) and is suitable for either bench or rack operation. It is of the Constant Current/Voltage Limiting type that will furnish full rated output current at the maximum rated output voltage or can be continuously adjusted throughout the output range. The front panel VOLTAGE control is used to establish the output voltage limit (ceiling) when the supply is used as a constant current source. This control is continuously variable throughout the entire voltage range. The front panel CURRENT control can be used to establish the output current limit (overload or short-circuit) if the supply is used as a voltage limited source.

1-5 A single meter is used to measure either output voltage or current. The dual selection is accomplished by a METER switch on the front panel. Output current can be measured in one of three ranges in accordance with the RANGE switch setting on the front panel. Output voltage is measured in only one range.

1-6 The power supply has both front and rear terminals. Either the positive or negative output terminal may be grounded or the power supply can be operated floating at up to a maximum of 300 Volts off ground (added safety precautions should be

taken to protect the operator when the supply is used in this mode).

1-7 Terminals at the rear of the unit allow access to various control points within the unit to expand the operating capabilities of the instrument. A brief description of these capabilities is given below:

a. Remote Programming. The power supply can be programmed (controlled) from a remote location by means of an external voltage source or resistance. The output current can be rapidly programmed in the up or down direction using this technique. Remote programming speed is less than 500 μ sec from zero to 99% of maximum rated output with an accuracy of 1%.

b. External Voltage Monitoring. The output voltage of the supply can be externally monitored with an accurate differential or digital voltmeter for applications involving component testing or sorting. Connecting the external meter to the guard voltage prevents output performance degradation when this feature is employed.

c. AC Modulation of Output. An external ac component (or varying dc) can be superimposed on the dc output current of the supply. This feature permits measurement of dynamic impedance, voltage breakdown, and leakage resistance.

1-8 SPECIFICATIONS

1-9 Detailed specifications for the power supply are given in Table 1-1.

1-10 OPTIONS

1-11 Options are factory modifications of a standard instrument that are requested by the customer. The following options are available for the instrument covered by this manual. Where necessary, detailed coverage of the options is included throughout the manual.

<u>Option No.</u>	<u>Description</u>
14	<u>Three Digit Graduated Decadal Current Control:</u> Control that replaces 10-turn current control permitting resettability to within 0.1%.
28	<u>Rewire For 230V AC Input:</u> Supply as normally shipped is wired for 115Vac input. Option 28 consists of

reconnecting the input transformer for 230Vac operation.

1-12 ACCESSORIES

1-13 The applicable accessories listed in the following chart may be ordered with the instrument or separately from your local Hewlett-Packard field sales office (refer to list at rear of manual for addresses).

<u>Part No.</u>	<u>Description</u>
5060-0808	Rack Kit for mounting one or two units. (Refer to Section II for details.)
5060-0097	Filler panel to block unused half of rack when mounting only one unit.

1-14 INSTRUMENT IDENTIFICATION

1-15 Hewlett-Packard instruments are identified

by a three-part serial number tag. The first part is the unit model number. The second part is the serial number prefix, which consists of a number-letter combination that denotes the date of a significant design change. The number designates the year, and the letter A through L designates the month, January through December respectively, with I omitted. The third part is the instrument serial number.

1-16 If the serial number prefix on your unit does not agree with the prefix on the title page of this manual, change sheets are included to update the manual. Where applicable, backdating information is given in an appendix at the rear of the manual.

1-17 ORDERING ADDITIONAL MANUALS

1-18 One manual is shipped with each instrument. Additional manuals may be purchased from your local Hewlett-Packard field office (see list at rear of this manual for addresses). Specify the model number, serial number prefix, and Part No. provided on the title page.

Model 6177B, Specifications

INPUT:

115Vac ± 10%, single phase, 48-63Hz, 0.6 Amp, 55 Watts (nominal).

OUTPUT:

0-500mA @ 50 Volts.

OUTPUT CURRENT RANGES:

0-500mA, 0-50mA, or 0-5mA.

LOAD REGULATION:

Less than 25ppm of output + 5ppm of range switch setting for a full load to no load change in output voltage.

LINE REGULATION:

Less than 25ppm for any line voltage change within the input rating.

RIPPLE AND NOISE:

Output Range (mA)	Ripple and Noise-rms/pk-pk (dc to 20MHz)
500	40µA/250µA
50	4µA/40µA
5	0.4µA/5µA

TEMPERATURE RANGES:

Operating: 0 to 55°C. Storage: -40 to +85°C.

TEMPERATURE COEFFICIENT:

Less than 75ppm of output plus 5ppm of range switch setting per degree centigrade.

STABILITY:

Less than 100ppm of output + 25ppm of range switch setting total drift. Measured for 8 hours after an initial warm-up time of one hour at constant ambient, constant line voltage, and constant load.

INTERNAL IMPEDANCE AS A CONSTANT CURRENT SOURCE:

Output Range (mA)	Output Impedance (R in parallel with C)*
500	R = 3.3 Meg, C = 0.05µf
50	R = 33 Meg, C = 0.005µf
5	R = 330 Meg, C = 500pf

*The formula $Z = R X_C / \sqrt{R^2 + X_C^2}$ can be used for calculations, up to 1MHz.

LOAD TRANSIENT RECOVERY TIME:

Less than 200µsec for output current recovery to within 1% of the nominal output current following a full load voltage change in the output voltage.

METER:

The front panel meter can be used as a 0-300mA, 0-30mA, or 0-3mA ammeter or a 0-120V voltmeter.

OUTPUT CONTROLS:

Range switch selects desired output current range and meter/line switch controls input power and selects meter range. Ten-turn current and single-turn voltage controls permit continuous adjustment over the entire output span.

OUTPUT TERMINALS:

Four output posts are provided on the front panel and two output terminal strips are located on the rear of the chassis. All power supply output terminals are isolated from the chassis and either the positive or negative terminal may be connected to the chassis through a separate ground terminal located on the front panel.

PROGRAMMING SPEED:

Less than 500µsec are required to program from zero and to 99% of the maximum rated output current of each range or between the maximum rated output current of each range to within 1% of zero.

REMOTE PROGRAMMING, CONSTANT CURRENT:

Programming Source	Range (mA)		
	500	50	5
Resistance (Accuracy: 1% of output + 0.04% of range)	4Ω/mA	40Ω/mA	400Ω/mA
Voltage (Accuracy: 0.5% of output + 0.04% of range)	2mV/mA	20mV/mA	200mV/mA

REMOTE PROGRAMMING, VOLTAGE LIMIT:

Remote programming of the voltage limit at approximately 870 ohms per Volt is made available at the rear terminals.

COOLING:

Convection cooling is employed; no moving parts.

SIZE:

3-7/16" H x 12-3/8" D x 7-3/4" W.

WEIGHT: 10 lbs. net, 13 lbs. shipping.

SECTION II INSTALLATION

2-1 INITIAL INSPECTION

2-2 Before shipment, this instrument was inspected and found to be free of mechanical and electrical defects. As soon as the instrument is unpacked, inspect for any damage that may have occurred in transit. Save all packing materials until the inspection is completed. If damage is found, file a claim for damage with the shipper. Hewlett-Packard Sales and Service Office should be notified.

2-3 MECHANICAL CHECK

2-4 This check should confirm that there are no broken knobs or connectors, that the cabinet and panel surfaces are free of dents and scratches, and that the meter is not scratched or cracked.

2-5 ELECTRICAL CHECK

2-6 The instrument should be checked against its electrical specifications. Section V includes an "in-cabinet" performance check to verify proper instrument operation.

2-7 INSTALLATION DATA

2-8 The instrument is shipped ready for bench operation. It is necessary only to connect the instrument to a source of power and it is ready for operation.

2-9 LOCATION

2-10 This instrument is air cooled. Sufficient space should be allotted so that a free flow of cooling air can reach the sides and rear of the instrument when it is in operation. It should be used in an area where the ambient temperature does not exceed 50°C.

2-11 OUTLINE DIAGRAM

2-12 Figure 2-1 illustrates the outline shape and dimensions of the 6177B and 6181B supplies.

2-13 RACK MOUNTING

2-14 This instrument may be rack mounted in a standard 19 inch rack panel either alongside a similar unit or by itself. Figure 2-2 shows how both

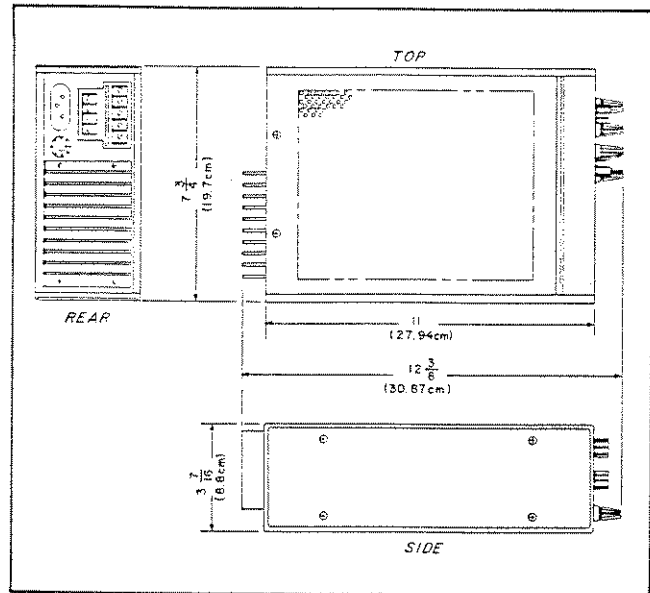

Figure 2-1. Outline Diagram

types of installations are accomplished.

2-15 To mount one, or two units side-by-side, proceed as follows:

- a. Place adaptor frame on bench.
 - b. Remove feet from submodular instruments.
- Place instrument(s) in frame.
- c. Place divider clamps between instruments.
 - d. Place divider clamps in position on each end and push the instrument combination into frame.
 - e. Insert screws on either side of frame and tighten.

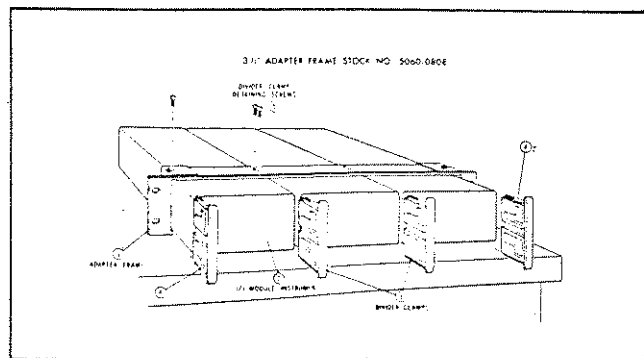

Figure 2-2. Rack Mounting One and Two Units

2-16 INPUT POWER REQUIREMENTS

2-17 This power supply may be operated from either a nominal 115 Volt or 230 Volt 48-63Hz power source. The unit, as shipped from the factory, is wired for 115 Volt operation. The input power required when operated from a 115 Volt 60Hz power source at full load is 55 Watts and 0.6 Ampere.

2-18 CONNECTIONS FOR 230 VOLT OPERATION (Figure 2-3)

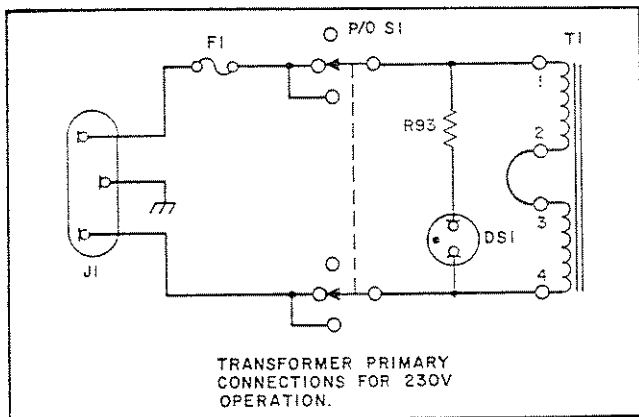

Figure 2-3. Primary Connections

2-19 Normally, the two primary windings of the input transformer are connected in parallel for operation from 115 Volt source. To convert the power supply to operation from a 230 Volt source, the power transformer windings are connected in series as follows:

a. Unplug the line cord and remove the bottom cover from the unit.

b. Unsolder jumper between taps 1 and 3 and taps 2 and 4. These taps are shown in Figure 2-4, and are located on the bottom of the unit.

c. Solder jumper between taps 2 and 3.

d. Replace existing fuse with 0.5 Ampere, 230 Volt fuse. Replace cover and operate unit normally.

2-20 POWER CABLE

2-21 To protect operating personnel, the National Electrical Manufacturers Association (NEMA) recommends that the instrument panel and cabinet be grounded. This instrument is equipped with a three conductor power cable. The third conductor is the ground conductor and when the cable is plugged into an appropriate receptacle, the instrument is grounded. The offset pin on the power cable three-prong connector is the ground connection.

2-22 To preserve the protection feature when operating the instrument from a two-contact outlet, use a three-prong to two-prong adapter and connect the green lead on the adapter to ground.

2-23 REPACKAGING FOR SHIPMENT

2-24 To insure safe shipment of the instrument, it is recommended that the package designed for the instrument be used. The original packaging material is reusable. If it is not available, contact your local Hewlett-Packard field office to obtain the materials. This office will also furnish the address of the nearest service office to which the instrument can be shipped. Be sure to attach a tag to the instrument which specifies the owner, model number, full serial number, and service required, or a brief description of the trouble.

SECTION III OPERATING INSTRUCTIONS

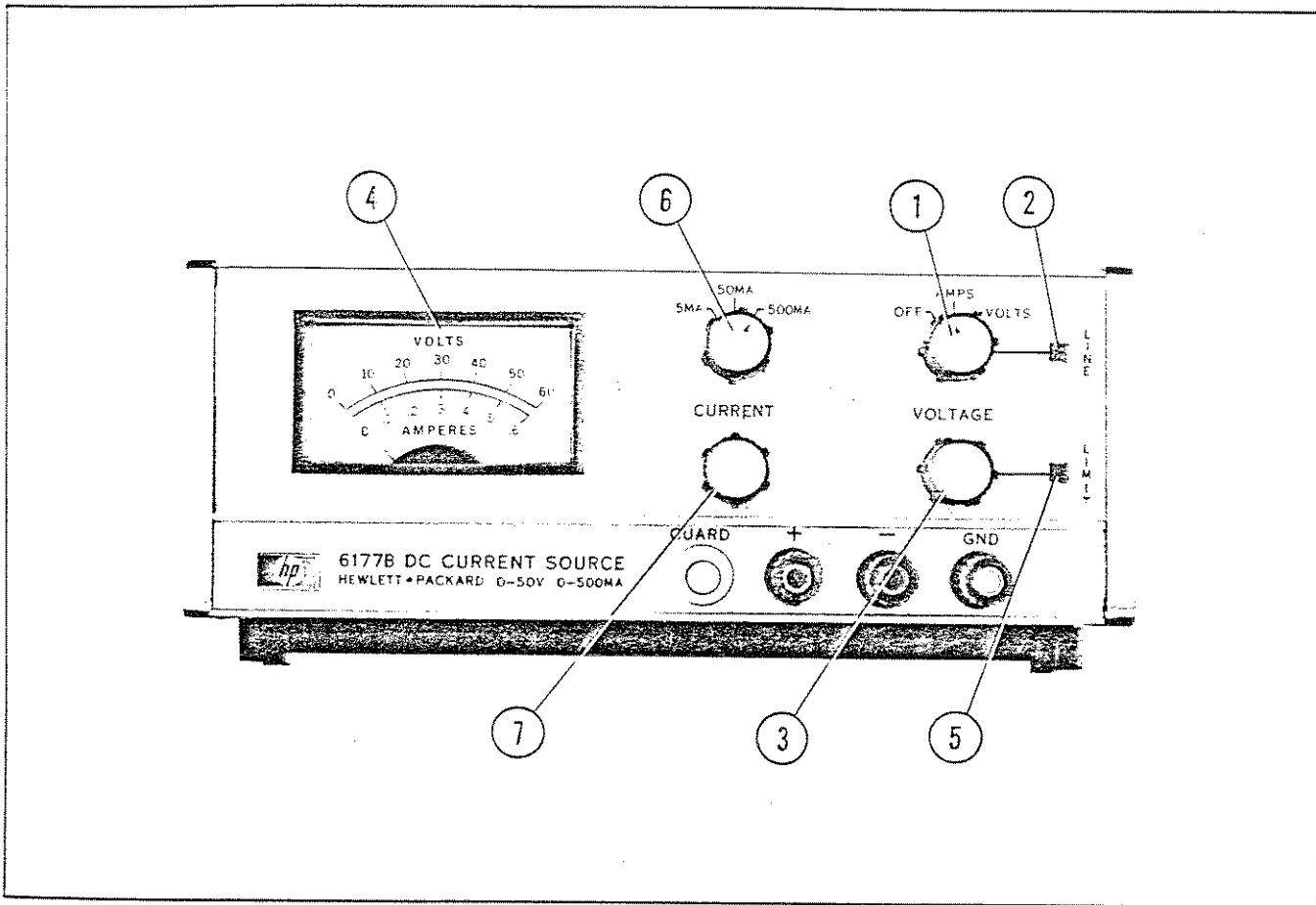

Figure 3-1. Operating Controls and Indicators

3-1 TURN-ON CHECKOUT PROCEDURE

3-2 The following checkout procedure describes the use of the front panel controls and indicators and ensures that the meter and programming circuits are operable. Actual output current should be checked with an external ammeter before connecting delicate loads.

- a. Set line/meter switch (1) to VOLTS and observe that LINE light (2) goes on.
- b. To select voltage limit, adjust VOLTAGE control (3) until front panel meter (4) indicates desired output voltage (no load connected).
- c. VOLTAGE LIMIT lamp (5) should be on with no load connected.
- d. To select constant current output, turn-off supply and short + and - output terminals (front

or rear).

- e. Set switch (1) to AMPS and select desired output current range with range switch (6). Adjust CURRENT control (7) for desired output current.

- f. Remove short and connect load to output terminals (front or rear).

3-3 OPERATING MODES

3-4 The power supply is designed so that its mode of operation can be selected by making strapping connections between particular terminals on the terminal strips at the rear of the power supply. The terminal designations are stenciled in white on the power supply above or below their

respective terminals. The operator can ground either terminal or operate the power supply up to 300Vdc off ground (floating). If one output terminal is to be grounded, the ground connection must be made at the front panel since the rear terminal strips do not contain a ground terminal. The load may be connected to either the front or rear terminals without degrading the performance of the supply in any way.

3-5 The following paragraphs describe the procedures for utilizing the various operational capabilities of the power supply. A more theoretical description concerning the operational features of this supply is contained in Application Note 90, Power Supply Handbook, available at no charge from your local Hewlett-Packard sales office.

3-6 NORMAL OPERATING MODE

3-7 The power supply is normally shipped with its rear terminal strapping connections arranged for Constant Current/Voltage Limiting, local programming, single unit mode of operation. This strapping pattern is illustrated in Figure 3-2. The operator merely selects a constant current output using the front panel controls (local programming, no strapping changes are necessary).

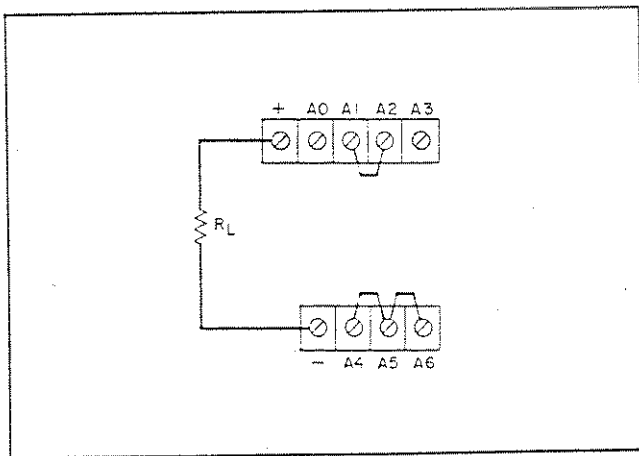

Figure 3-2. Normal Strapping Pattern

3-8 CONSTANT CURRENT

3-9 To select a constant current output, proceed as follows:

- a. With output terminals shorted or open (see NOTE), adjust CURRENT control for desired output current.
- b. With output terminals open, adjust VOLTAGE control for maximum output voltage allowable (voltage limit), as determined by load conditions. If a load change causes the voltage limit to be ex-

ceeded, the power supply will automatically crossover to constant voltage output at the preset voltage limit and the output current will drop proportionately. When this occurs, the VOLTAGE LIMIT lamp on the front panel will light. In setting the voltage limit, allowance must be made for high peak voltages which can cause unwanted crossover. (Refer to Paragraph 3-34.)

NOTE

When the unit is operating in the voltage limit mode (LIMIT lamp on) the front panel ammeter indicates the programmed output current rather than the actual output current. This enables the operator to set the output current (using the front panel CURRENT control) without shorting the output terminals.

3-10 CONNECTING LOAD

3-11 Loads for a constant current source must always be connected in series (never in parallel). If the supply is used as a voltage limited source, the reverse is true — the loads must be connected in parallel. For constant current operation, extreme care must be taken to avoid shunt paths external to the power supply. The presence of shunt paths will tend to degrade the performance of the supply. If the load is remotely located from the supply, shunt paths can be avoided by using shielded cable. If the supply is used as a positive source (negative terminal grounded) one end of the shield can be connected to the guard terminal (designated GUARD on the front and terminal A0 on the rear) and the other end left unconnected. This effectively projects the internal guard voltage along the shield affording absolute protection against leakage. If the supply is used as a negative source the above method cannot be utilized. However, the use of a shielded cable will be sufficient to prevent shunt leakage for most applications.

CAUTION

Never connect the negative output terminal to the GUARD (terminal A0 on the rear). This places a high negative potential at the input of differential amplifiers Q18 and Q19 and will result in damage to these components.

3-12 OPERATION OF SUPPLY BEYOND RATED OUTPUT

3-13 The shaded area on the front panel meter face

indicates the amount of output current or voltage that is available in excess of the rated output. Although the supply can be operated in this shaded region without being damaged, it cannot be guaranteed to meet all of its performance specifications. However, if the line voltage is maintained above 115Vac, the supply will probably operate within its specifications.

3-14 OPTIONAL OPERATING MODES

3-15 REMOTE PROGRAMMING, CONSTANT CURRENT

3-16 Either a resistance or a voltage source can be used to control the constant current output of the supply. The CURRENT control on the front panel is disabled when remote programming the supply.

3-17 Resistance Programming (Figure 3-3). In this mode, the output current varies at a rate determined by the remote resistance programming coefficient. This coefficient is different for each output current range, as shown in Table 1-1 of this manual. The programming coefficient is determined by the constant current programming current which is adjusted to $500 \pm 5\mu\text{A}$ at the factory. If greater programming accuracy is required, it can be achieved by changing resistor R35 as outlined in Section V.

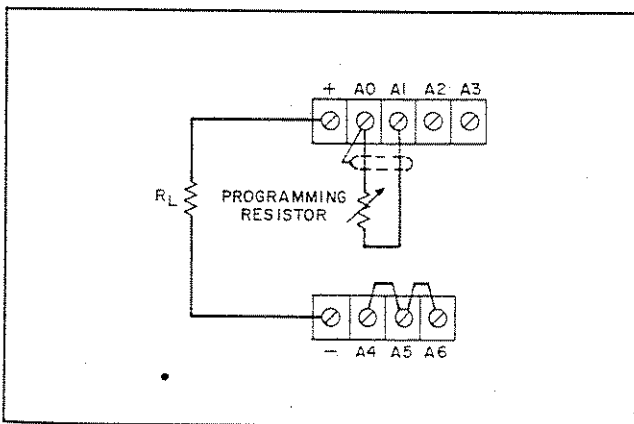

Figure 3-3. Remote Resistance Programming, Constant Current

3-18 Use stable, low noise, low temperature coefficient programming resistors to maintain the power supplies temperature coefficient and stability specifications. A switch may be used to set discrete values of output current. A make-before-break type of switch should be used since the output current will exceed the maximum rating of the power supply if the switch contacts open during the switching interval.

CAUTION

If the programming terminals (A0 and A1) should open at any time in the remote programming mode, the output current will rise to a value that may damage the power supply and/or the load. A protection resistor ($2K\Omega$ Model 6177B or $5K\Omega$ Model 6181B) can be connected across the programming terminals to avoid the possibility; however, note that the addition of the resistor will alter the linear programming coefficient given in Table 1-1.

3-19 If the negative output terminal of the supply is grounded, care must be taken to avoid leakage current paths from the programming source to the negative output terminal (ground). Shunt paths such as this, will seriously degrade the performance of the supply.

3-20 Voltage Programming (Figure 3-4). In this mode, the output current varies at a linear rate determined by the voltage programming coefficient given in Table 1-1. The entire voltage span for the source is approximately 0-1 Volt (Model 6177B) or 0-2.5 Volts (Model 6181B). The programming voltage should never exceed 1.2 Volts (Model 6177B) or 3 Volts (Model 6181B). Voltages in excess of this will result in excessive power dissipation in the instrument and possible damage.

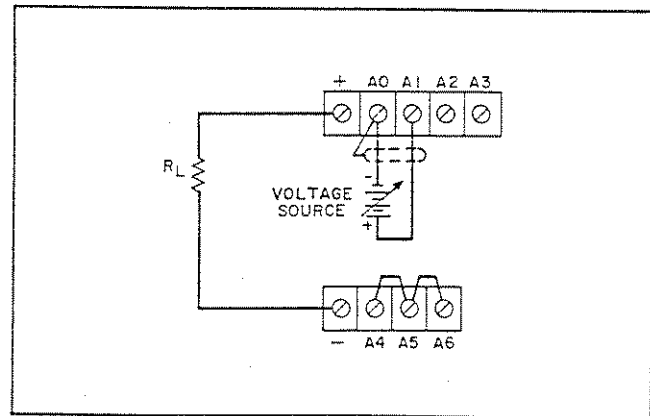

Figure 3-4. Remote Voltage Programming, Constant Current

3-21 The $500\mu\text{A}$ programming current, flowing into terminal A1 from the reference supply (see schematic), imposes two restrictions in the voltage programming mode. The first restriction is that the voltage source must be capable of sinking (absorb-

ing) this 500 μ A current and the second restriction is that, if the programming terminals are opened, the programming current will cause the output current to rise to an excessive level (refer to CAUTION note of Paragraph 3-18). Protection resistors, previously mentioned in the CAUTION note, can be employed to limit the output current to a safe value under any conditions.

3-22 If the user finds that his voltage source cannot sink the 500 μ A programming current, the programming current path to terminal A1 can be opened by removing resistor R37 from the main printed circuit board. This does not detract from the voltage programming performance in any way; but does eliminate the need for sinking the programming current. Opening R37 also obviates the need for an open terminal protection resistor. Opening the programming terminals with no programming current results in zero output current instead of an excessive output current.

3-23 If the negative output terminal of the supply is grounded, the voltage source must be floating (ungrounded). In addition, shunt leakage paths from the floating source to the negative terminal must be avoided. To accomplish this, the case of the voltage source can be connected to the guard terminal (A0) affording complete protection against leakage. If this method is used, ensure that the case is not grounded by any other means; such as the power line.

3-24 REMOTE PROGRAMMING, VOLTAGE LIMIT

3-25 The voltage limit of the supply can be programmed with a remote resistance or voltage source if required. Note that the front panel VOLTAGE control is disconnected by the following procedures.

3-26 Resistance Programming (Figure 3-5). The voltage limit of the supply is determined by the programming coefficient — 870 Ω per Volt for Model 6177B or 435 Ω per Volt for Model 6181B. The voltage programming current is 1.15mA (Model 6177B) or 2.3mA (Model 6181B) and is factory adjusted to within 20%. Adjustment of the programming accuracy can be achieved by changing resistor R6 as described in Section V.

3-27 A switch can be used in conjunction with various resistance values in order to obtain discrete voltages. The switch should have make-before-break contacts to avoid momentarily opening the programming terminals during the switching interval. Opening the programming terminals (- and A6) causes the output voltage to rise above normal and may damage the load device.

3-28 Voltage Programming (Figure 3-6). In this

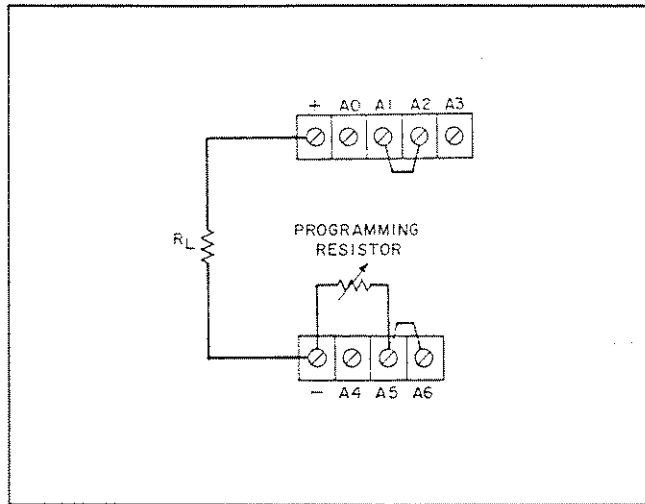

Figure 3-5. Remote Resistance Programming, Voltage Limit

mode, the voltage limit will vary in a 1 to 1 ratio with the programming voltage (voltage source). Similar to voltage programming the output current, Paragraph 3-19, the voltage source used must be capable of sinking the 1.15mA (Model 6177B) or 2.3mA (Model 6181B) programming current flowing into terminal A5. If the users source cannot absorb this current, the programming current path can be opened by disconnecting the collector lead of Q2 (see schematic). This does not adversely affect the operation of the supply in any way.

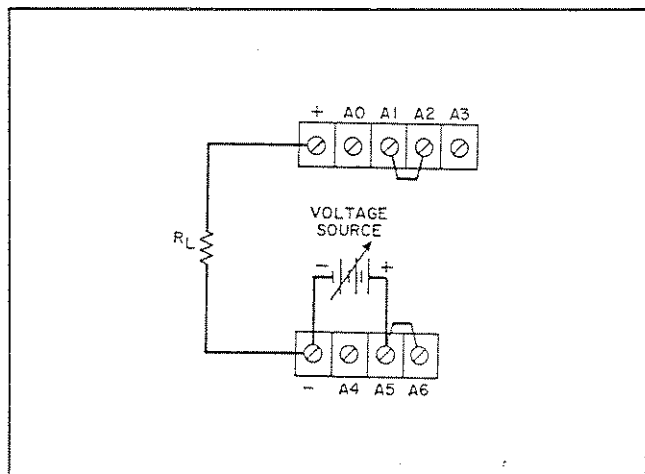

Figure 3-6. Remote Voltage Programming, Voltage Limit

3-29 EXTERNAL VOLTAGE MONITORING

3-30 If accurate indications of output voltage are required, they can be obtained with an external

voltmeter, as shown in Figure 3-7. Notice that one end of the meter is connected to the guard terminal (A0). This effectively isolates the meter from the main power supply, preventing the performance degradation that would occur if the meter were connected directly across the + and - output terminals.

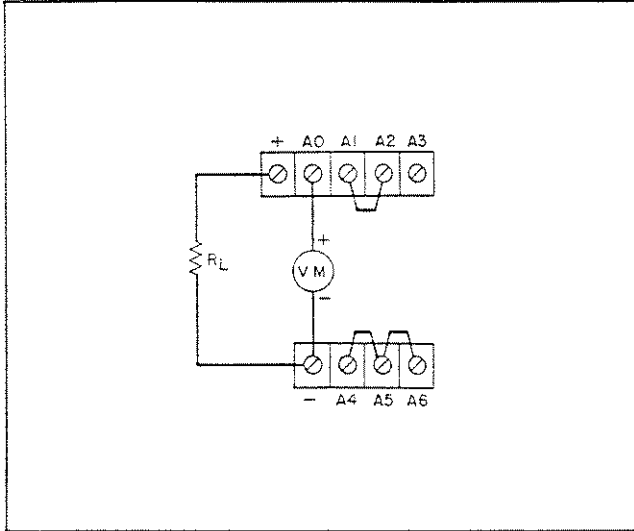

Figure 3-7. External Voltage Monitoring

NOTE

The external voltmeter must not draw more than 2mA from the auxiliary source that provides the guard voltage. A current drain in excess of 2mA will seriously impair the operation of the power supply.

3-31 EXTERNAL AC MODULATION

3-32 Figure 3-8 shows a method of superimposing an ac component on top of the adjustable dc output current of the supply, which is operating as a constant current source. The dc current level is controlled in the normal fashion from the front panel while the ac component of the output current is determined by the modulation percentage. The percentage of modulation is affected by the amplitude of the external voltage input and the value of the series resistance, as follows: % Modulation = $E_{source} (pk-pk) / R_x$ (in $K\Omega$). Using the above formula, the user would require an external resistance of $2K\Omega$ and a 2 Volts peak-to-peak input signal from the external source to modulate a dc current level of 100mA by 100%. In this case, the output current would swing between 200mA and zero Am-

peres. The output current should never be allowed to swing beyond the rating of the supply (500mA, p-p, for Model 6177E or 250mA, p-p, for Model 6181B) or clipping of the output and possible internal damage will result.

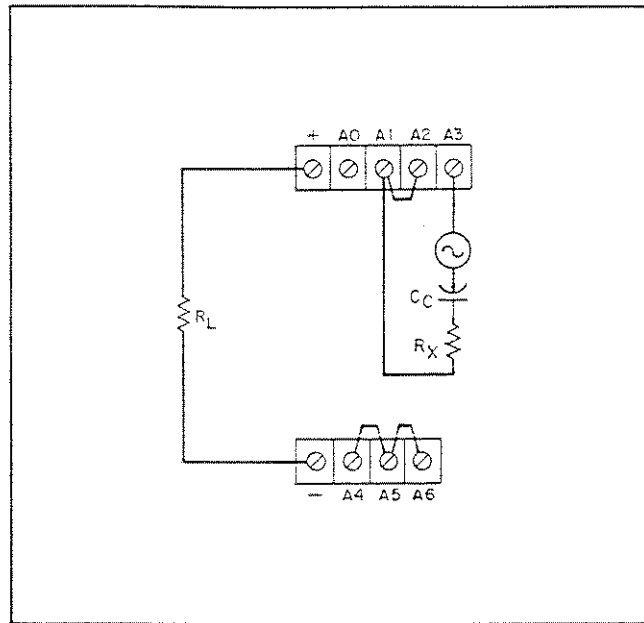

Figure 3-8. External AC Modulation

3-33 The coupling capacitor (C_c) should be chosen so that its reactance is at least ten-times smaller than R_x at the frequency of interest. For input frequencies up to 100Hz the output of the supply can be modulated 100%. Above 100Hz the modulation capability decreases linearly to approximately 10% at 1000Hz.

3-34 Notice that it is possible to remotely program the dc output current of the supply in the external modulation mode of operation. This can be accomplished by removing the strap between A1 and A2 and connecting the programming source across these terminals.

3-35 SPECIAL OPERATING CONSIDERATIONS

3-36 PULSE LOADING

3-37 The power supply will automatically cross over from constant current to voltage limiting operation in response to an increase (over the preset limit) in the output voltage. Although the preset limit may be set higher than the average output voltage high peak voltages (as occur in pulse loading) may exceed the preset limit and cause crossover to occur. If this crossover limiting is not desired, set the preset limit for the peak requirement and not the average.

3-38 REVERSE VOLTAGE LOADING

3-39 Diode CR34 is connected internally across the supply. Under normal operating conditions, the diode is reverse biased (anode connected to negative terminal). If a reverse voltage is applied to the output terminals (positive voltage applied to negative terminal), the diode will conduct, shunting current across it. This diode protects the series transistors and drivers.

3-40 REVERSE CURRENT LOADING

3-41 An active load connected to the power supply

may actually deliver a reverse current to the power supply during a portion of its operating cycle. An external source cannot be allowed to pump current into the supply without loss of regulation. Diodes CR35 and CR36, connected in series with the negative output lead, protect internal components from damage by blocking these reverse currents. However, to avoid regulation degradation, it is necessary to preload the supply with a dummy load resistor so that the power supply delivers current through the entire operating cycle of the load device.

SECTION IV PRINCIPLES OF OPERATION

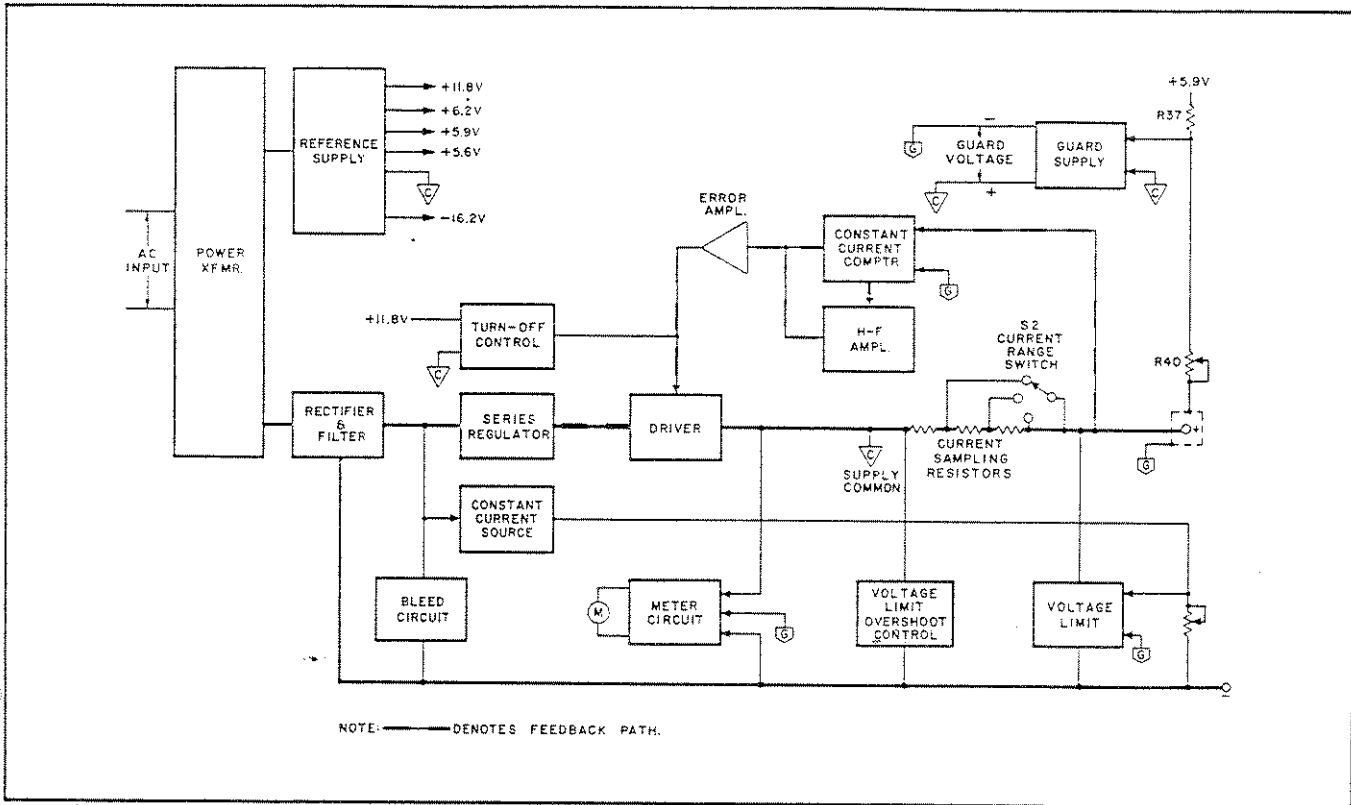

Figure 4-1. Overall Block Diagram

4-1 OVERALL BLOCK DIAGRAM DISCUSSION

4-2 The major circuits of the supply are shown in the overall block diagram, Figure 4-1. The input ac line voltage passes through the power transformer to the filter (6177B) or voltage doubler (6181B) where it is converted to raw (unregulated) dc. This dc current is adjusted by the series regulator so that a well-regulated constant current is fed to the output terminals. The range of the output current is selected by the range switch which determines the value of current sampling resistance to be placed in series with the (+) output terminal.

4-3 During normal (constant current) operation, the conduction of the series regulator is controlled by feedback signals originated by the constant current comparator. This circuit compares the voltage drop across the applicable current sampling resistance with the potential of the guard supply. The voltage drop across the sampling resistor(s) is proportional to the output current, and the potential of

the guard supply is proportional to the programmed output current, as will be explained in the next two paragraphs. If a difference exists, that is, if the actual output current does not equal the programmed output current, the comparator sends an "error" signal to the series regulator, via the error amplifier and driver. This error signal alters the conduction of the series regulator so that the potential across the sampling resistance equals the guard voltage.

4-4 The guard supply is an independent constant voltage supply whose output is used to voltage program the output current of the unit. The guard supply compares the output of the guard with a fixed reference voltage and ensures that their difference is equal to zero Volts (∇). The voltage drop across the CURRENT control, R40, equals the output voltage of the guard with respect to common. A change in the setting of R40 momentarily unbalances a differential amplifier within the guard, which causes the guard voltage to change by an equal amount. This alteration balances the differential

amplifier.

4-5 The adjusted output of the guard supply is then used as the reference on which the error signals produced by the constant current comparator are based. A change in the output of the guard supply results in a change in the feedback signal produced by the constant current comparator. This then causes the output current of the unit to vary in proportion to the change "programmed" by the guard supply.

4-6 The output of the guard supply is fed to a copper guard which surrounds the positive output terminal. Circuitry, which would cause shunt current paths across the output of the supply, is connected to the guard rather than the positive output terminal. Since the (+) output terminal, with respect to common ∇ , is held at the same potential as the guard with respect to common, no leakage current can flow between the two points. Any leakage current that does flow within the unit comes from the guard supply rather than the positive output terminal. In this way leakage current, across the output of the supply is eliminated and exact load regulation is obtained.

4-7 The meter circuit provides a continuous indication of the output current or voltage. Since it is tied to the guard rather than the output terminals, the operation of the meter circuit does not create any degradation in the output of the supply. This connection also enables the operator to program the output current before connecting the load.

4-8 The voltage limit circuit continuously monitors the output voltage. If this voltage exceeds the preset limit established by the VOLTAGE limit controls, a shunt regulator in the circuit is driven into conduction thus limiting the output voltage by the amount of its conduction. The constant current source provides a constant current to the VOLTAGE limit control, thus, ensuring linear programming of the voltage limit threshold.

4-9 Large increases in output voltage, too fast for the voltage limit circuit to manage, are limited by the voltage limit overshoot control. This circuit acts as soon as the voltage reaches the voltage limit threshold. It clamps the output voltage to about 7 Volts above the voltage limit setting until the voltage limit circuit can respond to the high voltage condition.

4-10 The turn-off control prevents reverse currents from flowing through the series regulator and driver at turn-off. It accomplishes this by reverse biasing the driver and series regulator when the supply is turned off.

4-11 The H-F amplifier improves the high frequency

gain of the unit. This then helps to improve the transient response of the unit to both changing load conditions and ac modulation (see Paragraph 3-31).

4-12 The bleed circuit keeps the series regulator biased in its active region even at low output current settings, by providing a continuous path for current flow through the series regulator. Keeping the series regulator biased in its active region allows the regulator to maintain fine regulation of output current even at low output levels.

4-13 The reference circuit provides stable voltages used throughout the unit for reference and biasing purposes.

4-14 As shown in Figure 4-1, the common point for this supply is at the inboard side of the sampling resistor(s). This is a significant point because it ensures that only the output current will flow through the sampling resistance. All offset currents (such as the meter current) are referenced to this common point and thus, do not flow through the sampling resistance and into the load. Notice that this point should not be used as a ground connection. A separate terminal is provided for this purpose.

4-15 DETAILED CIRCUIT ANALYSIS

4-16 REFERENCE SUPPLY

4-17 The reference supply is a feedback constant voltage supply which provides stable voltages used throughout the unit for reference and biasing purposes. All of the reference voltages are derived from the raw dc obtained from the full wave bridge rectifier (CR5, CR6, CR7, and CR8) and filter capacitor C3 and are measured with respect to the unit's common point ∇ . The +6.2, -16.2, and +5.6 voltages are developed across temperature compensated Zener diodes VR5, VR6, and VR12 respectively. The +5.9 reference voltage is developed at the base of Q15 which is biased by a voltage dropping resistor R35, factory selected to obtain this voltage. R34 limits the current through Zener diode VR5 to obtain the optimum positive bias level, +11.8 Volts.

4-18 The regulating circuit consists of series regulator transistors, Q11 and Q12, error amplifier, Q13, and differential amplifier Q14 and Q15. The base of Q14 is connected between voltage dividing resistors R29 and R30. Any changes in the output voltage of the circuit are reflected on the base of Q14, amplified, inverted, and fed to Q13. Q13 amplifies and inverts this signal which is used to drive the series regulating transistors more or less in order to maintain the +11.8 Volt reference, and thus the other reference voltages, constant.

4-19 An additional voltage is provided at the input of the reference circuit. This voltage (+24V unregu-

lated) is not controlled by the regulator circuit and is used in less critical circuitry of the unit.

4-20 CONSTANT CURRENT COMPARATOR

4-21 The constant current comparator is a differential amplifier that compares the drop across the sampling resistor(s) to the guard potential and if a difference exists, sends an error signal proportional to this difference to the series regulator via the main error amplifier. The error signal alters the conduction of the regulator thus keeping the output constant and at the desired programmed level.

4-22 The comparator consists of a differential amplifier, Q19, and a constant current source, Q21. Q19 consists of two silicon transistors housed in a single package. The transistors have matched characteristics minimizing differential voltages due to mismatched stages. Moreover, drift due to thermal differentials is minimal since both transistors operate at essentially the same temperature. Potentiometer, R56 allows further balancing of the stage should this be necessary. CR25 and CR26 prevent excessive voltage excursions from over driving the stage.

4-23 The constant current comparator acts in conjunction with the guard supply to set and maintain the output current at the desired level. It continuously compares the drop across the sampling resistance, which is proportional to the output current, to the potential of the guard supply, which is equal to the programmed output current (as will be explained, subsequently). If a difference exists, the comparator sends an error signal to the series regulator, via the main error amplifier and driver, in order to maintain the output current equal to the current programmed by the guard supply.

4-24 The RANGE switch selects the proper value of current sampling resistance. These values of resistance maintain equal voltage drops for proportional output current in each range. For instance; in the 5181B, in the 25mA range, the sampling resistance is 100 Ω , creating a voltage drop of 2.5 Volts across the sampling resistors at maximum output. In the 250mA range, the sampling resistance is 10 Ω , again creating a 2.5 Volt drop.

4-25 GUARD SUPPLY

4-26 The guard supply is a self-contained, constant voltage supply, which compares a portion of the guard potential to a fixed reference voltage and ensures that their difference is zero.

4-27 The guard supply consists of a differential amplifier, Q18, error amplifier and series regulator Z2. The differential amplifier consists of two silicon transistors housed in a single package. The

transistors have matched characteristics, minimizing differential voltages due to mismatched stages. Moreover, drift due to thermal differentials is minimal since both transistors operate at essentially the same temperature. Q22, acting as a constant current source for the differential amplifier, is used to bias the emitters of both transistors. Potentiometer, R46, allows further balancing of the differential amplifier should this be necessary. CR15 and CR16 form a limiting network which prevents excessive voltage excursions from over driving the stage.

4-28 The output of the guard supply is fed to a copper guard which surrounds the positive output terminal. As previously mentioned, this prevents leakage currents across the output terminals of the supply.

4-29 Stage Q18E is connected to the common point of the unit. The base of Q18A is connected to a summing point (A1) at the junction of the programming resistor, R40, and the current pullout resistor, R37. Instantaneous changes in the guard potential result in an increase or decrease in the summing point potential and thus, unbalances the differential amplifier. An error signal is then produced and fed to the series regulator of the guard supply causing it to conduct more or less in accordance with the summing point change. This restores the potential of the guard which balances the differential amplifier.

4-30 R37, connected to the +5.9 reference voltage, acts to provide a constant programming current through potentiometer R40, which ensures linear programming by R40. Changing the setting of the potentiometer changes the potential at A1. This creates a momentary imbalance at the input of the differential amplifier, which then sends an error signal to the regulator to alter the guard voltage and correct the difference. R36, connected in series with R40, acts to make up any difference which might be created by the tolerance of the potentiometer, by providing an additional current through R40. This then ensures full range programming by the CURRENT control.

4-31 H-F ERROR AMPLIFIER

4-32 The H-F amplifier improves the high frequency gain of the unit. This then helps to improve the transient response of the unit to both changing load conditions and ac modulation (see Paragraph 3-31).

4-33 MAIN ERROR AMPLIFIER AND DRIVER

4-34 The main error amplifier (Z1) receives the feedback signal, amplifies it and feeds it to the driver stage. Q26, Q27, and Q28 form the driving circuit for the series regulator. This circuit further amplifies the feedback signal, inverts it and the resultant signal is used to bias the emitter of the

series regulator thus controlling the conduction of the regulating stage.

4-35 If the voltage programming terminals were to open when the output was open circuited, the output voltage could go up as high as 200 Volts. VR14 and VR15 serve as a protection against this condition. When the voltage reaches approximately 140-Volts, the Zener diodes reach their break down potential and clamp the output to 140 Volts. This prevents break down of other elements which would not be able to withstand this very high voltage. VR13 operates in the same capacity should the voltage programming of the guard supply fail.

4-36 SERIES REGULATOR

4-37 The series regulator regulates the output of the supply by altering its conduction in accordance with the feedback error signal. The circuit consists of series regulating transistors, Q30 and Q29, and a base biasing source, Q25. By altering its conduction in accordance with the error signal applied to it, the series regulator produces a well regulated output at the level established by the current controls.

4-38 Notice that the series regulator is connected in a common base configuration. This increases the output impedance of the supply thus giving it the desired quality of a constant current supply. A more detailed description concerning the desired features of a constant current supply is contained in Application Note 90 available at your local Hewlett-Packard field office.

4-39 TURN-OFF CONTROL

4-40 The turn-off control circuit prevents reverse currents from flowing through the series regulator at turn-off. It accomplishes this by sending a turn-down signal to the series regulator via the driver.

4-41 During normal operation of the supply, Q31 supplies a bias potential to the driver. At turn-off, CR30 becomes reversed biased. Q31 turns off quickly, due to the discharging of capacitor C34. This creates a negative potential at the base of Q26, turning off both the driver and the series regulator.

4-42 BLEED CIRCUIT

4-43 The bleed circuit provides a path for 20mA of current to flow through the series regulator. This keeps the series regulator biased in its active region at all times. The bleed current flows from the +24 Volt unregulated reference through Q1, back up to the collector of the series regulator, through the driver to common ∇ where it returns to the -16.2 reference voltage through VR6. Notice that this

current does not go through the load nor through the sampling resistors. When the supply is programmed for zero current, 20mA are flowing through the common node, however, zero current is actually delivered to the load. Keeping the series regulator biased in its active region at all times makes it possible to have good load regulation even at low output currents.

4-44 VOLTAGE LIMIT CIRCUIT

4-45 The voltage limit circuit acts to limit the potential across the output terminals to some preset limit established by the VOLTAGE limit control. The circuit consists of a voltage limit control, R81, feedback amplifiers Q4, Q5, and Q6, shunt regulator Q7, voltage limit lamp DS2, and lamp driver Q8. Under normal operating conditions, Q7 is turned off. When the voltage limit threshold is reached, a negative feedback signal is sent to the feedback amplifiers. The signal is inverted, amplified and fed to the shunt regulator and lamp driver. This signal causes both transistors to conduct. The output voltage is limited by the amount of conduction of Q7. Also, with Q8 on, a current path is completed through Q8 and DS2, thus DS2 turns on warning the operator of the voltage limit condition. Notice that since the voltage limit section of the supply employs a separate shunt regulator, the main series regulator continues to regulate output current even during voltage limit operation.

4-46 Potentiometer R81 permits adjustment of the base potential of Q4 with respect to (-) out, thus setting the point at which the voltage limit threshold is reached.

4-47 Constant Current Source. The constant current source, Q2 and associated components, provides a constant programming current through the VOLTAGE limit control, R81, thus ensuring linear programming of the voltage limit circuit. VR2 keeps the base of Q2 at a constant voltage ensuring a constant current output. R6 is selected at the factory to bias the emitter of Q2 so that the proper programming current is obtained.

4-48 Turn-On Circuit. C40 and R41 form a long time constant RC network. When the supply is initially turned on, a turn-on signal is fed to Q7 via Q6. This limits the output, thus preventing turn-on overshoot from damaging delicate loads. After the supply has been on for a short time, C40 charges up, back biasing CR40 and thus the turn-on circuit has no effect on normal operation of the supply.

4-49 VOLTAGE LIMIT OVERSHOOT CONTROL

4-50 This fast acting circuit protects the load from initial large, fast rises in output voltage that the voltage limit circuit would not otherwise be able to

limit. As soon as the voltage limit threshold is exceeded, the voltage limit overshoot control clamps the output voltage to a few Volts above the threshold setting, until Q7 has a chance to turn on to limit the output.

4-51 When the voltage limit threshold is exceeded, Q3 conducts heavily causing CR12 to become forward biased and VR4 and VR7 to reach their breakdown voltages. This draws current from the +5.6-Volt reference. Since the +5.6 Volt reference is tied to common through VR12, the above action actually draws current from common away from the load, thus limiting the output to the preset voltage limit setting plus about 7 Volts.

4-52 METER CIRCUIT

4-53 The meter circuit provides a continuous indication of the output current, in any one of three ranges, or the output voltage. The meter ranges are controlled by the same switch that controls the output current ranges. For this reason, when the range switch is moved to the next higher range, the output current changes to ten times the original value, but the needle on the meter will not move. However, it should be understood that the meter is now reading ten times the indicated value. The reverse is true when switching to the next lower range.

4-54 Notice that the ammeter is connected from common ∇ to guard and the voltmeter from (-) out to guard. As explained previously, the (+) output terminal is kept at the same potential as the guard. Thus, the ammeter is actually reading the voltage across the sampling resistance which is proportional to the output current, and the voltmeter reads the actual output voltage. Connecting the meter to guard eliminates any shunt current paths which might be created by the meter circuit. It also allows the operator to program the output before connecting the load, since the meter reads the programmed output current.

4-55 ADDITIONAL FEATURES

4-56 Two diodes (CR35 and CR36) placed in series with the negative output terminal, prevent reverse current from flowing into the supply and possibly damaging its components. They also allow the supply voltage limit to be programmed through zero by offsetting minor base to emitter voltage drops in the voltage feedback loop.

4-57 R80, connected across the supply, keeps the supply from oscillating with an inductive load connected. CR34 prevents reverse voltages from damaging the supply.

SECTION V MAINTENANCE

5-1 INTRODUCTION

5-2 Upon receipt of the power supply, the performance check (Paragraph 5-5) should be made. This check is suitable for incoming inspection. If a fault is detected in the power supply while making the performance check or during normal operation, proceed to the troubleshooting procedures (Paragraph 5-38). After troubleshooting and repair (Paragraph 5-48), perform any necessary adjustments and calibrations (Paragraph 5-50). Before returning the power supply to normal operation,

repeat the performance check to ensure that the fault has been properly corrected and that no other faults exist. Before performing any maintenance checks, turn-on power supply and allow a half-hour warm-up.

5-3 TEST EQUIPMENT REQUIRED

5-4 Table 5-1 lists the test equipment required to perform the various procedures described in this Section.

Table 5-1. Test Equipment Required

TYPE	REQUIRED CHARACTERISTICS	USE	RECOMMENDED MODEL
Differential Voltmeter	Sensitivity: 1mV full scale (min.). Input impedance: 10 megohms (min.). Resolution: 1 ppm of range.	Measure dc voltages; calibration procedures	Ⓢ 3420 (See Note)
Variable Voltage Transformer	Range: 90-130 Volts. Equipped with voltmeter accurate within 1 Volt.	Vary ac input	---
Ac Voltmeter	Accuracy: 2%. Sensitivity: 0.1mV full scale deflection (min.).	Measure ac voltages and rms ripple	Ⓢ 400 F
Oscilloscope	Sensitivity: 100 μ V/cm. Differential input.	Display transient response waveforms	Ⓢ 140A plus 1400A plug in. 1402A plug-in for noise measurements.
Dc Voltmeter	Accuracy: 1%. Input resistance: 20,000 ohms/Volt (min.).	Measure dc voltages	Ⓢ 412A
Repetitive	Rate: 60 - 400Hz, 2 μ sec rise and fall time.	Measure transient response and programming speed	See Figures 5-5 and 5-7
Resistive Loads	Values: See Figure 5-3, 30 Watts.	Power supply load resistors	---
Current Sampling Resistors	Values: See Figure 5-3, 0.5%, 10Watts, 5ppm, 4-Terminal.	Measure current; calibrate meter	R1, R2 and R3; see parts table.

Table 5-1. Test Equipment Required (Continued)

TYPE	REQUIRED CHARACTERISTICS	USE	RECOMMENDED MODEL
Resistor	Value: See Paragraph 5-57. ±0.1%, $\frac{1}{2}$ Watt.	Calibrate programming current	---
Decade Resistance Box	Range: 0-100K. Accuracy: 0.1% plus 1 ohm Make-before-break contacts.	Adjust programming accuracy	---

NOTE

A satisfactory substitute for a differential voltmeter is to arrange a reference voltage source and null detector as shown in Figure 5-1. The reference voltage source is adjusted so that the voltage difference between the supply being measured and the reference voltage will have the required resolution for the measurement being made. The voltage difference will be a function of the null detector that is used. Examples of satisfactory null detectors are: ④ 419A null detector, a dc coupled oscilloscope utilizing differential input, or a 50mV meter movement with a 100 division scale. For the latter, a 2mV change in voltage will result in a meter deflection of four divisions.

CAUTION

Care must be exercised when using an electronic null detector in which one input terminal is grounded to avoid ground loops and circulating currents.

5-5 PERFORMANCE TEST

5-6 The following test can be used as an incoming inspection check and appropriate portions of the test can be repeated either to check the operation of the instrument after repairs or for periodic maintenance tests. The tests are performed using a 115Vac 60Hz, single phase input power source. If the correct result is not obtained for a particular check, do not adjust any controls; proceed to troubleshooting (Paragraph 5-38).

5-7 CONSTANT CURRENT TESTS

5-8 For output current measurements, the current

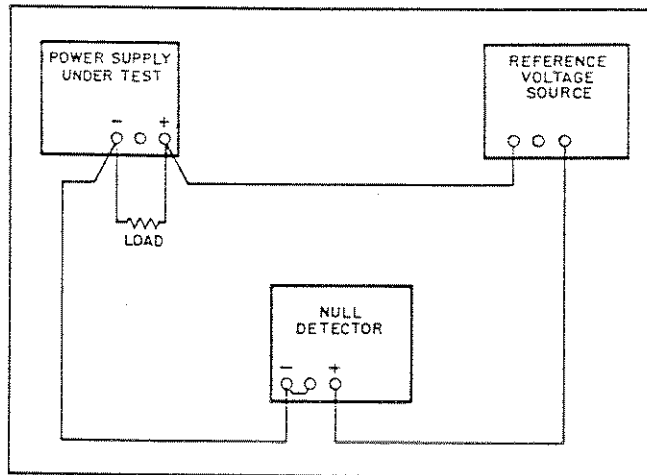

Figure 5-1. Differential Voltmeter, Substitute Test Setup

sampling resistor must be treated as a four terminal device. In the manner of a meter shunt, the load current is fed to the extremes of the wire leading to the resistor while the sampling terminals are located as close as possible to the resistance portion itself (see Figure 5-2). In addition, the resistors should be of the precision, low noise, low temperature coefficient (less than 10ppm/°C) type and should be used at no more than 10% of their rated power so that the temperature rise will be minimized. The latter, reduces resistance

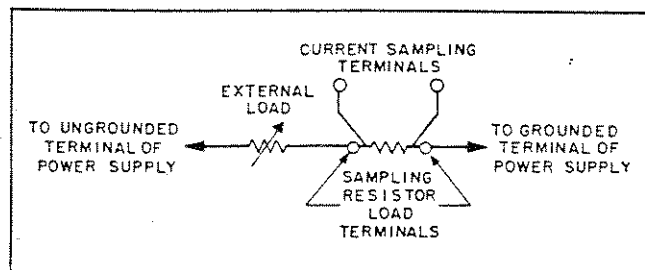

Figure 5-2. Output Current Measurement Technique

changes due to thermal fluctuations. If the user experiences difficulty in obtaining adequate sampling resistors, it is recommended that he obtain duplicates of the sampling resistors (R1, R2, and R3) that are used in the unit.

5-9 The monitoring device is connected across the sampling resistors as shown in Figure 5-3. As indicated in this illustration neither output terminal of the power supply is grounded and the measuring device case is connected to the junction of the load and sampling resistors. This arrangement prevents ground loop paths and shunt current paths. Notice that shunt resistance paths between the external switches and ground can exist. However, since the shunt resistance appears across only one of the external resistors and not across the entire output terminals of the supply, the performance of the supply is not degraded.

5-10 RATED OUTPUT AND METER ACCURACY

5-11 Current. To check the output current for all three ranges, proceed as follows:

- Connect test setup shown in Figure 5-3, leaving switch S2 open throughout test.
- Turn VOLTAGE control fully clockwise.
- Set range switch on front panel to highest current position (500mA Model 6177A, or 250mA Model 6181A).
- Set range switch S1 on external test set-up to high range and connect + terminal of differential voltmeter to R_{S1}.
- Set front panel meter switch to AMPS and adjust CURRENT control until front panel meter indicates exactly the maximum rated output current for this particular range.
- Differential voltmeter should read as follows:

Model	6177B	6181B
Reading	2.5 ± 0.05Vdc	1 ± 0.02Vdc

If it does not, refer to adjustment procedure at rear.

- To check the medium current range, set the range switches on the front panel and the external test setup to their middle position and differential voltmeter to R_{S2}. Then, repeat Steps e and f. (Readings of Step f apply to every current range.)
- To check the low current range, set both range switches to the low current position and repeat Steps e and f.

5-12 Voltage. To check the output voltage proceed as follows:

- Connect test setup of Figure 5-3 except connect the differential voltmeter between the guard (terminal A0) and - output terminals (see Figure 3-7 for voltmeter connections).

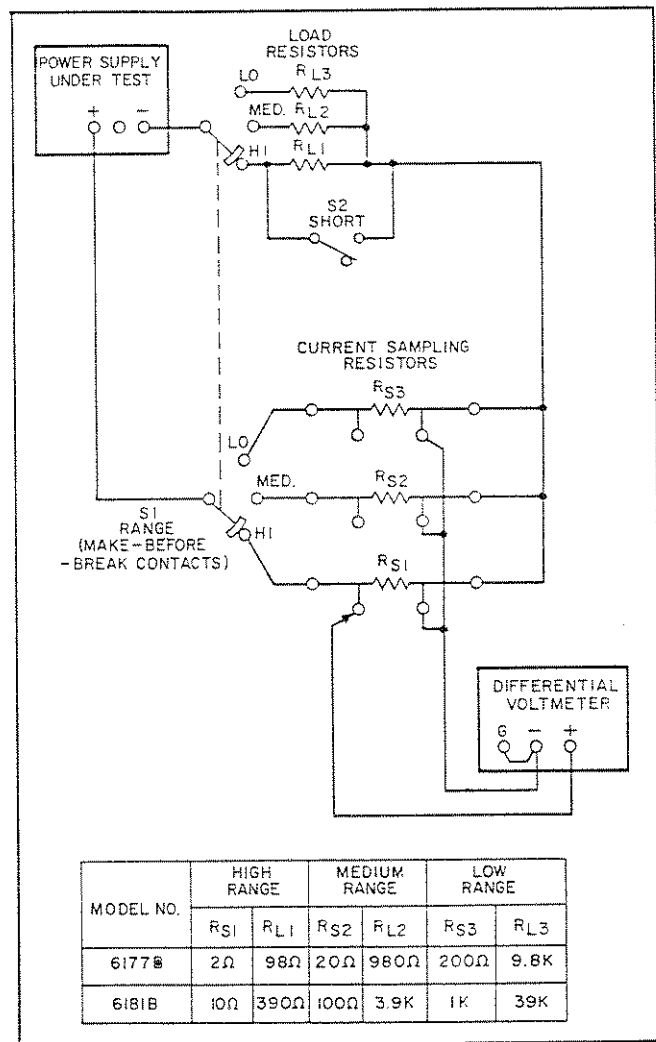

Figure 5-3. Output Current Test Setup

- Set range switches to highest current positions and meter switch to VOLTS position.
- Turn VOLTAGE control fully clockwise and turn on supply
- Adjust CURRENT control until front panel meter indicates exactly the maximum rated output voltage.
- Differential voltmeter should indicate the maximum rated output voltage within ±2%. If it does not, refer to adjustment procedure at rear.

5-13 LOAD REGULATION

Definition: The change, ΔI_{OUT} in the static value of the dc output current resulting from a change in load resistance from short circuit to a value which yields maximum rated output voltage.

5-14 To check the constant current load regula-

tion for all three output ranges proceed as follows:

- Connect test setup shown in Figure 5-3.
- Turn VOLTAGE control fully clockwise.
- Set internal and external range switches

to highest current positions. Connect + side of differential voltmeter to RS_1 .

d. Set meter switch to AMPS and adjust CURRENT control until front panel meter reads exactly the maximum rated output current.

e. Read and record voltage indicated on differential voltmeter.

f. Short out load resistor (R_{L1}) by closing switch S2.

g. Reading on differential voltmeter should not vary from reading recorded in Step e by more than the following:

Model No.	6177B	6181B
Variation (μ Vdc)	± 30	± 75

h. To check the load regulation for the middle current range, open shorting switch S2 and set range switches on front panel and external test setup to their middle position. Connect differential voltmeter to RS_2 .

i. Next, repeat Steps d through g. Variation should not exceed the reading of Step g.

j. To check the load regulation for the lowest current range, open switch S2 and set both range switches to their low current position. Then repeat Steps d through g.

5-15 LINE REGULATION

Definition: The change, ΔI_{OUT} in the static value of dc output current resulting from a change in ac input voltage over the specified range from low line (usually 103 Volts) to high line (usually 127 Volts), or from high line to low line.

5-16 To check the constant current line regulation for all three ranges proceed as follows:

a. Utilize test setup shown in Figure 5-3, except connect variable auto-transformer between input power source and power input to supply. Leave switch S2 open throughout test.

b. Turn VOLTAGE control fully clockwise.

c. Set range switches on front panel and external test setup to highest current positions and connect + lead of differential voltmeter to RS_1 .

d. Set meter switch to AMPS and adjust auto transformer for 103Vac input.

e. Adjust CURRENT control for maximum rated output current on front panel meter.

f. Read and record voltage indicated on differential voltmeter.

g. Adjust auto transformer for 127Vac input.

h. Reading on differential voltmeter should not vary from reading recorded in Step f by more

than the following:

Model No.	6177B	6181B
Variation (μ Vdc)	± 25	± 63

i. To check line regulation for medium current range set both range switches to their middle position and connect differential voltmeter to RS_2 .

j. Next repeat Steps d through h. Variation should not exceed the reading of Step h.

k. For the lowest current range, set both range switches to the appropriate positions and repeat Steps d through h.

5-17 RIPPLE AND NOISE

Definition: The residual ac current which is superimposed on the dc output current of a regulated supply. Ripple and noise may be specified and measured in terms of its RMS or (preferably) peak-to-peak value.

5-18 RMS Measurement. To check the rms ripple and noise, proceed as follows:

a. Use test setup of Figure 5-3, except connect ac voltmeter across sampling resistors instead of differential voltmeter. Ensure that power supply output is floating to avoid ground loops.

NOTE

To prevent extraneous 60Hz pickup, the external range switch and load resistors (R_L and R_S) should be enclosed in a shielded box. Also, the sampling leads connected to the ac meter should be twisted or shielded.

b. Rotate VOLTAGE control fully clockwise.

c. Set range switches to highest current range. Connect + side of ac voltmeter to RS_1 .

d. Set meter switch to AMPS and adjust CURRENT control until front panel meter indicates exactly the maximum rated output current.

e. The ac voltmeter should read less than the following:

Model No.	6177B	6181B
Reading	80 μ V rms	200 μ V rms

f. To check ripple and noise for the medium and low current ranges, set both range switches to their appropriate positions, and ac voltmeter to appropriate current sampling resistor. Then repeat Steps d and e.

5-19 High Frequency Noise Measurement. When measuring high frequency noise, an oscilloscope of sufficient bandwidth (up to 20MHz) must be

used. Figure 5-4A shows a correct method of measuring the output ripple of a constant current supply using a single-ended scope. Ground loop paths are broken by floating the output terminals of the supply.

5-20 Either a twisted pair or (preferably) a shielded two-wire cable should be used to connect the output terminals of the power supply to the vertical input terminals of the scope. When using shielded two-wire, it is essential for the shield to be connected to ground at one end only so that no ground current will flow through this shield, thus inducing a noise signal in the shielded leads.

5-21 To verify that the oscilloscope is not displaying ripple that is induced in the leads or picked up from the grounds, the (+) scope lead should be shorted to the (-) scope lead at the power supply terminals. The ripple value obtained when the leads are shorted should be subtracted from the actual ripple measurement.

5-22 In most cases, the single-ended scope method of Figure 5-4A will be adequate to eliminate non-real components of ripple and noise so that a satisfactory measurement may be obtained. However, in more stubborn cases, or in measurement situations where it is essential that both the power supply case and the oscilloscope case be connected to ground (e. g. if both are rack-mounted), it may be necessary to use a differential scope with floating input as shown in Figure 5-4B. If desired, two single conductor shielded cables may be substituted in place of the shielded two-wire cable with equal success. Because of its common mode rejection, a differential oscilloscope displays only the difference in signal between its two vertical input terminals, thus ignoring the effects of any common mode signal introduced because of the difference in the ac potential between the power supply case and scope case. Before using a differential input scope in this manner, however, it is imperative that the common mode rejection capability of the scope be verified by shorting together its two input leads at the power supply and observing the trace on the CRT. If this trace is a straight line, the scope is properly ignoring any common mode signal present. If this trace is not a straight line, then the scope is not rejecting the ground signal and must be realigned in accordance with the manufacturer's instructions until proper common mode rejection is attained.

5-23 To check the high frequency noise output, proceed as follows:

- a. Connect test setup shown in Figure 5-4A or 5-4B.
- b. Set front panel and external range switches to highest current range.

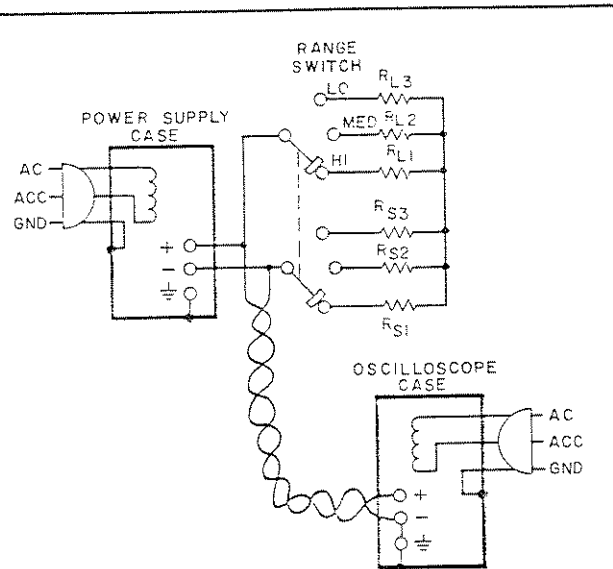

A. MEASUREMENT METHOD USING A SINGLE-ENDED SCOPE. OUTPUT TERMINALS OF SUPPLY ARE FLOATED TO BREAK GROUND CURRENT LOOPS, TWISTED PAIR REDUCES STRAY PICKUP ON SCOPE LEADS.

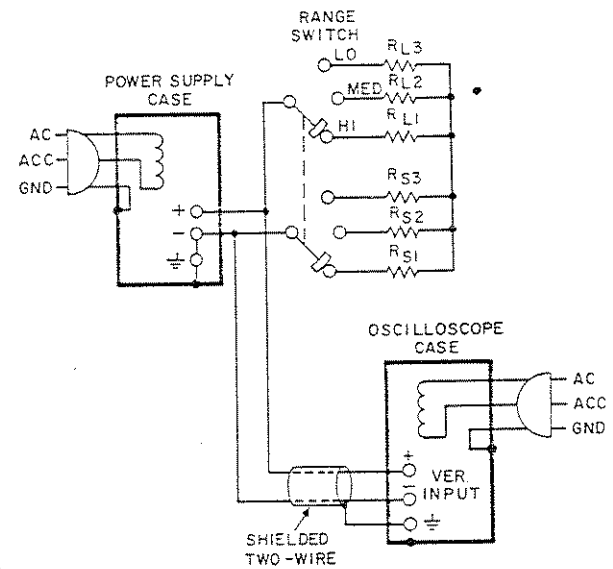

B. BETTER METHOD USING DIFFERENTIAL SCOPE WITH FLOATING INPUT, GROUND CURRENT PATH IS BROKEN; COMMON MODE REJECTION OF DIFFERENTIAL INPUT SCOPE IGNORES LIKE POLARITY INPUTS, SHIELDED WIRE FURTHER REDUCES STRAY PICKUP ON SCOPE LEADS.

NOTES:
FOR VALUES OF LOAD RESISTORS (R_L AND R_S) SEE FIGURE 5-3 OR TABLE 5-1. FOR HIGH FREQUENCY MEASUREMENTS, LOW INDUCTANCE RESISTORS SHOULD BE USED.

Figure 5-4. High Frequency Ripple and Noise, Test Setup

- c. Set meter switch to AMPS and adjust CURRENT control for maximum rated output current.
- d. Observed noise should be less than 25mV

- p-p (Model 6177B) or 40mV p-p (Model 6181B).
- e. Set range switches to medium range and adjust for rated output current of that range.
- f. Observed noise should be less than 40mV p-p (Model 6177B) or 32mV p-p (Model 6181B).
- g. Set range switches to lowest range and adjust for rated output current of low range.
- h. Observed noise should be less than 50mV p-p (Model 6177B) or 20mV p-p (Model 6181B).

5-24 LOAD TRANSIENT RECOVERY TIME

Definition: The time "X" for output current recovery to within "Y" milliamps of the nominal output current following a "Z" amp step change in load voltage — where:
 "Y" is generally of the same order as the load regulation specification. The nominal output current is defined as the dc level half way between the static output current before and after the imposed load change, and "Z" is the specified load voltage change, normally equal to the full load voltage rating of the supply.

5-25 Transient recovery time may be measured at any input line voltage combined with any output voltage and load current within rating.

5-26 Reasonable care must be taken in switching the load resistance on and off. A hand-operated switch in series with the load is not adequate, since the resulting one-shot displays are difficult to observe on most oscilloscopes, and the arc energy occurring during switching action completely masks the display with a noise burst. Transistor load switching devices are expensive if reasonably rapid load current changes are to be achieved.

5-27 A mercury-wetted relay, as connected in the load switching circuit of Figure 5-5 should be used for loading and unloading the supply. When this load switch is connected to a 60Hz ac input, the mercury-wetted relay will open and close 60 times per second. Adjustment of the 25K control permits adjustment of the duty cycle of the load current switching and reduction in jitter of the oscilloscope display.

5-28 To check the load transient recovery time, proceed as follows:

- a. Connect test setup shown in Figure 5-5.
- b. Turn VOLTAGE control fully clockwise.
- c. Set meter switch to AMPS and range switch to highest current range.
- d. Adjust CURRENT control until front panel meter indicates exactly the maximum rated output current.
- e. Close line switch on repetitive load switch setup.

f. Adjust 25K potentiometer until a stable display is obtained on oscilloscope. Waveform should be within the tolerances shown in Figure 5-6. Output should return to within $\pm 10\text{mV}$ (Model 6177B) or $\pm 25\text{mV}$ (Model 6181B) of nominal value in less than 200 microseconds.

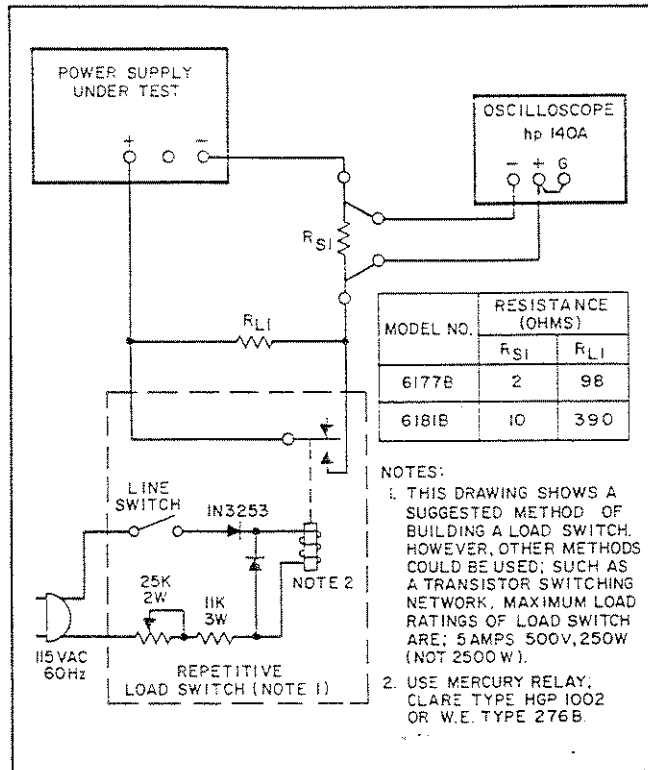

Figure 5-5. Load Transient Recovery Time, Test Setup

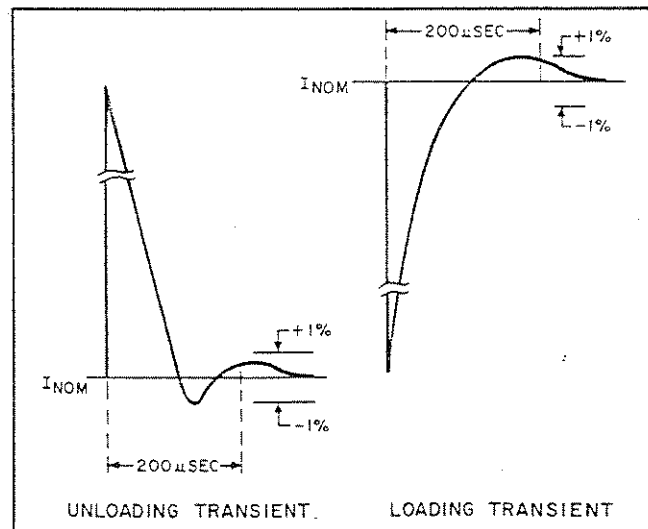

Figure 5-6. Load Transient Recovery Time, Waveforms

5-29 PROGRAMMING SPEED

Definition: The time (μ secs) required for the output current to change from zero amps to within "X" milliamps of the maximum rated output, or from maximum rated output to within "X" milliamps of zero. "X" is generally of the same order as the load regulation specification.

5-30 To check the constant current remote programming speed, proceed as follows:

- Connect test setup shown in Figure 5-7.
- Turn VOLTAGE control fully clockwise.
- Set meter switch to AMPS and range switch to highest current range.
- Adjust CURRENT control until front panel meter indicates exactly the maximum rated output current.
- Close line switch for mercury wetted relay and observe waveform on oscilloscope. Rise time indicates up-programming speed and decay time indicates down-programming speed.
- The programming speed should be within the tolerances of Figure 5-8. Output should go from zero to 99 Volts (Model 6177B) or from zero to 49.5 Volts (Model 6181B). Fall time (down programming) should be almost identical to the rise time shown on Figure 5-8 except for inversion.

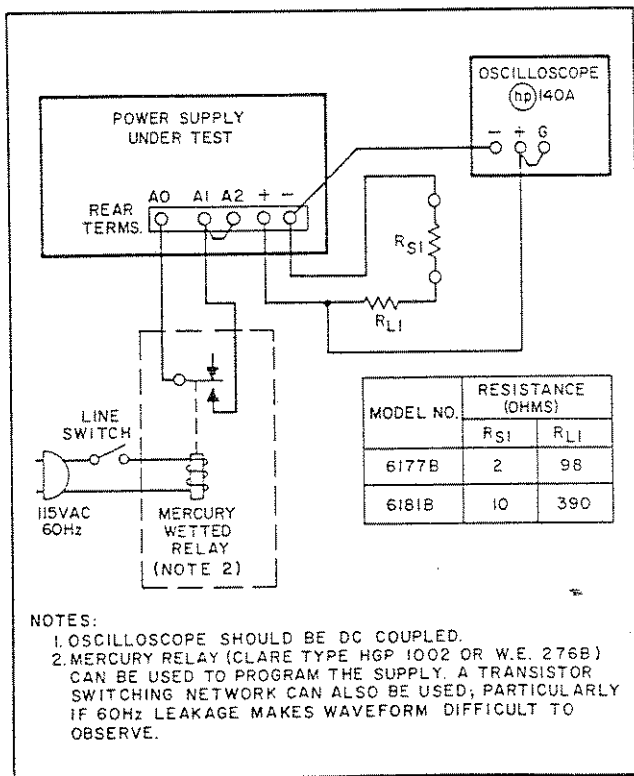

Figure 5-7. Programming Speed, Test Setup

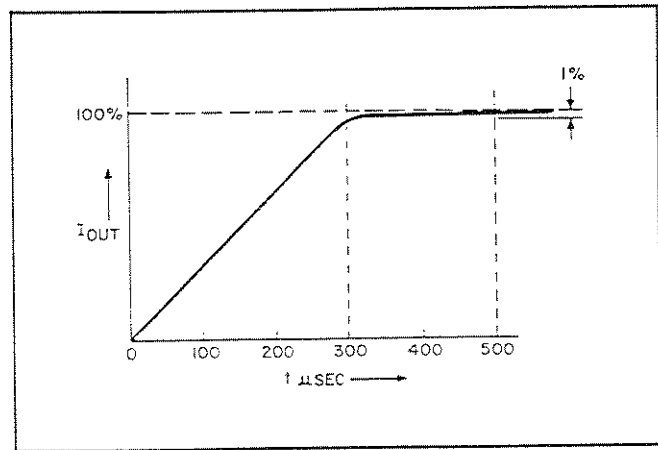

Figure 5-8. Up-Programming Speed Waveform

5-31 OUTPUT STABILITY

Definition: The change in output current for the first 8 hours following a 30 minute warm-up period. During the interval of measurement all parameters such as load resistance, ambient temperature, and input line voltage are held constant.

5-32 The stability of the supply in constant current operation must be measured while holding the temperature of the power supply and the external current sampling resistor (R_S) as constant as possible. A thermometer should be placed near the supply to verify that the ambient temperature remains constant during the measurement period. The supply should be located away from stray air currents; if possible, in an oven which is held at a constant temperature. Variations of the voltage across the current sampling resistor over the specified 8 hour interval are measured on the digital or differential voltmeter and may be recorded on a strip chart recorder. Since such voltage measurements are generally being made at a rather low level, it is important to check that the stability of the measuring instruments is adequate to insure an accurate check on the power supply performance.

5-33 To check the output stability, proceed as follows:

- Connect test setup shown in Figure 5-3.
- Turn VOLTAGE control fully clockwise.
- Set range switches to desired current range and + lead of differential voltmeter to applicable sampling resistor (R_{S1} , R_{S2} or R_{S3}).
- Set METER switch to AMPS and adjust CURRENT control to obtain rated output current.
- Allow one hour warm-up then record differential voltmeter indication.
- After 8 hours, differential voltmeter reading should not change by more than 125μ Vdc

(6177B) or 313 μ Vdc (6181B), in any output current range.

5-34 TEMPERATURE COEFFICIENT

Definition: The change in output current per degree Centigrade change in the ambient temperature under conditions of constant input ac line voltage, output current setting, and load resistance.

5-35 The temperature coefficient of the supply is measured by placing the supply in an oven and varying it over any temperature span within the rating. The current sampling resistor(s), R_S , should not be placed in the oven, but must be held at a constant temperature while this measurement is made.

5-36 The differential voltmeter used to measure the output current change of the supply should be placed outside the oven and should have a long term stability adequate to insure that its drift will not affect the overall measurement accuracy.

5-37 To check the temperature coefficient, proceed as follows:

- a. Connect test setup shown in Figure 5-3.
- b. Turn VOLTAGE control clockwise.
- c. Set range switches to desired current range and connect + lead of differential voltmeter to applicable sampling resistance (R_{S1} , R_{S2} or R_{S3}).
- d. Set METER switch to AMPS and adjust CURRENT control for rated output.
- e. Insert supply into temperature-controlled oven (voltmeter and load resistances remain outside oven). Set temperature to 30°C and allow one hour warm-up.
- f. Record differential voltmeter indication.
- g. Raise oven temperature to 40°C and allow one hour warm-up.
- h. Differential voltmeter indication should change by less than 800 μ Vdc (6177B) or 2mVdc (6181), in any output current range.

5-38 TROUBLESHOOTING

5-39 Before attempting to troubleshoot this instrument, ensure that the fault is with the instrument and not with an associated circuit. The performance test (Paragraph 5-5) enables this to be determined without having to remove the instrument from the cabinet.

5-40 A good understanding of principles of operation is a helpful aid in troubleshooting, and it is recommended that the reader review Section IV of the manual before attempting to troubleshoot the unit in detail. Once the principles of operation are

understood, refer to the overall troubleshooting procedures in Paragraph 5-43 to locate the symptom and probable cause.

5-41 The schematic diagram at the rear of the manual (Figure 7-3) contains normal voltage readings taken at various points within the circuits. These voltages are positioned adjacent to the applicable test points (identified by encircled numbers). Component and test point designations are marked on the component location diagrams, Figures 7-1 and 7-2.

5-42 If a defective component is located, replace it and recondact the performance test. When a component is replaced, refer to the repair and replacements, and adjustment and calibration paragraphs in this section.

5-43 OVERALL TROUBLESHOOTING PROCEDURES

5-44 To locate the cause of trouble, follow steps 1, 2, and 3 in sequence.

(1) Check for obvious troubles such as open fuse, defective power cord, input power failure or defective meter. Next remove the top and bottom covers (each held by retaining screws) and inspect for and correct open connections, charred components, etc. If the trouble source cannot be detected by visual inspection, proceed with Step (2).

(2) The reference circuit, in many cases, may be either a direct or indirect cause of trouble. For this reason it is a good idea to eliminate the circuit as the direct cause of trouble by following the steps and making the corrections listed in Table 5-2. If this procedure fails to correct the reference circuit and the symptom permanently, it is an indication that the reference circuit is an indirect cause of trouble and further inspection is needed, as described in Step (3).

(3) Disconnect the load and examine Table 5-3 to determine your symptom and probable cause. In most cases further isolation within the unit is necessary. When this is the case, Table 5-3 will direct the reader to the isolation procedures in this section.

5-45 ISOLATION PROCEDURES

5-46 Because of the interaction between various feedback loops, a symptom, at first inspection, may seem to be caused by one circuit when in actuality the trouble stems from a faulty component in a completely different circuit. For example; if the front panel current meter reading doesn't change while trying to program the supply up or down, the cause might seem to be in the programming supply, the guard. However, a faulty component in the constant current comparator, and even in the voltage limit circuit, could cause the same symptom. Since to troubleshoot all three circuits would involve a

Table 5-2. Reference Voltages
(Refer to the Schematic for Test Point Locations)

STEP	METER COMMON	METER POSITIVE	NORMAL VDC	NORMAL RIPPLE (P-P)	PROBABLE CAUSE
1	A3	3	11.8	1mV	VR12, Q11-Q15
2	A3	4	6.2	100 μ V	VR5
3	A3	5	5.9	100 μ V	VR5, adjustment of R35
4	A3	6	5.6	5 μ V	VR12
5	2	A3	16.2	2mV	VR6, Q1, VR1

Table 5-3. Overall Troubleshooting

SYMPTOM	PROBABLE CAUSE
Poor Programming Varying controls has little or no effect on front panel meter reading.	a. Main feedback loop, Guard, or voltage limit circuit defective. Proceed to Paragraph 5-45 for further isolation.
Actual Output Current (according to external meter) does not coincide with front panel meter reading. (May be higher or lower.)	a. Main feedback loop, Guard, or voltage limit circuit defective. Proceed to Paragraph 5-45 for further isolation.
Inability to Zero Guard	a. C23 defective. b. R49 defective.
High Ripple	a. C29 or Q20 leaky or defective. b. High ripple in reference circuit. See Table 5-2. c. Poor line regulation. d. Poor load regulation.
Poor Line Regulation	a. Improper measurement technique. See Paragraph 5-15. b. Check reference circuit. See Table 5-2. c. Check C1, C2, C5, and C13 for defect. d. Check CR1 and CR2 for defect.
Poor Load Regulation	a. Improper measurement technique. See Paragraph 5-13. b. Check for shunt leakage paths external to the supply. c. Check reference circuit. See Table 5-2. d. If poor load regulation exists in lower current ranges only, check bleed transistor Q1, for open and VR1 for short. e. Q3 shorted.
Unit Oscillates	a. C14, C20, C21, or C22 defective. b. C10, C11, or C35 defective.

Table 5-3. Overall Troubleshooting (Continued)

SYMPTOM	PROBABLE CAUSE
Unit Oscillates (Continued)	c. C1 or C13 defective. d. C23 and R49 defective. <p style="text-align: center;">NOTE</p> Isolation procedures described in Tables 5-4 to 5-7, in most cases, may be used to isolate oscillation troubles.
Instability	a. R40 noisy. b. Check reference circuit. See Table 5-2. c. Q18, Q19, Z1, or Z2 defective.
Unit Fails to Voltage Limit	a. Voltage limit not set properly. See Paragraph 3-2. b. Voltage limit defective. Check Q7 and Q6 for open, and Q5 and Q4 for short. Check CR9 and CR13 for open. c. Voltage limit overshoot control defective. Check Q3, CR12, VR4, and VR7 for open. Check C6 for short.
Poor Transient Response to AC Modulation or Load Changes	a. Q20 or C29 of the H-F Amplifier Circuit leaky.

time consuming and difficult process, a good isolation and test of each circuit is imperative. The following procedures provide a fast, efficient way to isolate and test each circuit. Before proceeding with this isolation, the reference circuit should be checked and eliminated as the direct cause of trouble as described in Paragraph 5-44 and Table 5-2.

5-47 The isolation procedures (Tables 5-4 through 5-10) should be followed in numerical sequence until the cause of trouble is isolated to a particular circuit. Instructions within these tables will direct the reader to either another isolation procedure or to a troubleshooting table, until the faulty component is located. Once this component is

found and replaced, re-conduct the performance tests in Section V to ensure that no further trouble exists. Note that sometimes it may be necessary to troubleshoot the instrument more than once because more than one circuit has become defective. The troubleshooting procedures should be repeated until all sources of trouble are located and corrected.

CAUTION

Keep the RANGE switch in the highest current position while troubleshooting. Switching to lower range may cause R2 or R3 to burn out.

Table 5-4. Isolation: Guard and Main Feedback Loop

<p>———— PURPOSE ————</p> <p>To isolate the guard circuit.</p> <p>———— PROCEDURE ————</p> <ol style="list-style-type: none"> 1. Disconnect the wires found at points A (yellow coated jumper) and B (white wire). Refer to Figure 7-2 for location of points A and B. 2. With the meter switch in the AMPS position, vary front panel CURRENT control and observe front panel meter.

Table 5-4. Isolation: Guard and Main Feedback Loop (Continued)

———— OBSERVATIONS AND CONCLUSIONS ————

1. If the meter varies from zero to within shaded area on meter face, this indicates that the guard supply is operable and the source of trouble lies elsewhere. If original trouble symptom was output current higher than the programmed value according to front panel meter, reconnect guard and proceed to Table 5-6. If original symptom was output current lower than the programmed value, reconnect guard and proceed to Table 5-5.
2. If meter does not vary proportionally to the CURRENT control setting, the source of trouble lies within the guard circuit. Proceed to Table 5-9.

Table 5-5. Isolation: Main Feedback Loop and Voltage Limit Circuit

———— PURPOSE ————

To isolate the voltage limit circuit.

———— PROCEDURE ————

1. Disconnect diode CR13 and resistor R19.
2. Disconnect Zener diode VR4.
3. Connect load resistor shown in Figure 5-3.
4. Connect voltmeter across load.
5. Vary front panel CURRENT control, observing both external voltmeter and unit's ammeter readings. Calculate actual output current and compare results with supply meter reading.

———— OBSERVATIONS AND CONCLUSIONS ————

1. If actual output current (according to calculated values) varies proportionally to programmed output (according to unit's ammeter), this indicates that the source of trouble is within the voltage limit circuit or overshoot control circuit. Proceed to Table 5-7.
2. If actual output current does not vary proportionally to programmed output, this indicates voltage limit circuit is operable and trouble lies elsewhere. Reconnect components and proceed to Table 5-6.

Table 5-6. Isolation: Series Regulator and Constant Current Comparator

NOTE

Because of the high current flowing through and around the series regulator, a slip of the hand while testing a component in this section may cause unpredictable reactions in other circuits. The following procedure describes a way to test the operation of the regulator and driver without endangering any other circuits.

———— PURPOSE ————

To isolate the series regulator and driver.

———— PROCEDURE ————

1. Disconnect Z1 by pulling it out of its socket.
2. Connect a 50K Ω potentiometer between common (A3) and Test Point 18. See Figure 7-2 for location of TP18.

Table 5-6. Isolation: Series Regulator and Constant Current Comparator (Continued)

<p>———— PROCEDURE (Continued) ————</p>	
<p>3. Short circuit positive and negative output terminals and connect a clip-on ammeter. A 10Ω resistor and a voltmeter connected across the output terminals may be used to replace the clip-on ammeter and shorted terminals.</p> <p>4. Set VOLTAGE limit control to maximum cw (current control has no effect on output now).</p> <p>5. Vary potentiometer observing clip-on ammeter (or calculate output current from reading on voltmeter).</p>	
<p>———— OBSERVATIONS AND CONCLUSIONS ————</p>	
<p>1. If output current varies from zero to maximum rated output, this indicates that the series regulator and driver are operable and that the constant current comparator or error amplifier are at fault. Reconnect Z1, disconnect short across output terminals, clip-on ammeter and potentiometer and proceed to Table 5-10.</p> <p>2. If the output current does not vary proportionally to the potentiometer setting, this indicates that the series regulator or driver is at fault. If the output current seems to be locked up, check Q25, Q26, Q27, Q28, Q29, and Q30 for short. If the output current seems to be locked down or if maximum rated output cannot be reached, check Q25, Q26, Q27, Q28, Q29, Q30, and Q31 for open or similar defect. Also check CR31, VR14, and VR15 for short.</p>	

Table 5-7. Isolation: Voltage Limit Overshoot Control and Voltage Limit Circuit

<p>———— PURPOSE ————</p>	
<p>To isolate the voltage limit overshoot circuit.</p>	
<p>———— PROCEDURE ————</p>	
<p>1. With supply still connected as described in Table 5-5, procedure steps 1, 2, 3, and 4, reconnect VR4.</p> <p>2. Vary front panel CURRENT control, observing both external voltmeter and unit's ammeter readings. Calculate actual output current and compare results with supply meter reading.</p>	
<p>———— OBSERVATIONS AND CONCLUSIONS ————</p>	
<p>1. If actual output current (according to calculated values) does not vary proportionally to the programmed output (according to unit's ammeter), this indicates that the source of trouble is within the overshoot control circuit. Check Q3, C6, CR12, VR4, and VR7 for short. Also check Q2 for open.</p> <p>2. If actual output current varies proportionally to the programmed output, this indicates that the trouble is within the voltage limit circuit. Reconnect components and proceed to Table 5-8.</p>	

Table 5-8. Troubleshooting Voltage Limit Circuit

STEP	ACTION	RESPONSE	PROBABLE CAUSE
	<p>NOTE</p> <p>During this procedure an external resistor and meter should be connected as described in Table 5-5, steps 3 and 4. The output current should be calculated accordingly.</p>		

Table 5-8. Troubleshooting Voltage Limit Circuit (Continued)

STEP	ACTION	RESPONSE	PROBABLE CAUSE
1	Check turn-off of Q7 and Q8 by disconnecting collector of Q6.	a. Output current remains low. b. Output current increases.	a. Q7, Q8 shorted. b. Reconnect collector and proceed to Step 2.
2	Eliminate the turn-on circuit as a source of trouble by disconnecting the anode of CR40.	a. Output current increases. b. Output current remains low.	a. CR40, C40 shorted. b. Reconnect CR40 and proceed to Step 3.
3	Check turn-off of Q6 by shorting Q5 emitter-to-collector.	a. Output current remains low. b. Output current increases.	a. Q6 shorted. b. Remove short and proceed to Step 4.
4	Check turn-on of Q5 by shorting Q4 emitter-to-collector.	a. Output current remains low. b. Output current increases.	a. Q5 open. b. Remove short and proceed to Step 5.
5	Check turn-on of Q4 by opening VR2 near the constant current source.	a. Output current remains low. b. Output current increases.	a. Q2, Q4 open. R81 shorted. Open strap between A5 and A6. b. VR2 shorted. Check R5 and R6 for open.

Table 5-9. Troubleshooting the Guard Circuit

STEP	ACTION	RESPONSE	PROBABLE CAUSE
PART A. UNIT LOCKED-UP			
1	Check the operation of Z2 by switching Z1 and Z2.	a. Output current decreases. b. Output current remains high.	a. Z2 defective. b. Proceed to Step 2.
2	Check operation of Q18 by opening strap between terminal A1 and A2.	a. Output current remains high. b. Output current decreases.	a. Q18A open. Q18B shorted. CR15, CR16 shorted. b. R40 shorted. R37 open.
PART B. UNIT LOCKED-DOWN			
1	Check operation of Z2 by switching Z1 and Z2.	a. Output current increases. b. Output current remains low.	a. Z2 defective. b. Proceed to Step 2.
2	Check operation of Q18 by shorting A0 to A1.	a. Output current remains low. b. Output current decreases.	a. Q18 shorted. Q21, VR10 open. b. R40 open. R36 shorted.

Table 5-10. Troubleshooting Constant Current Comparator and Main Error Amplifier

STEP	ACTION	RESPONSE	PROBABLE CAUSE
PART A. HIGH OUTPUT CURRENT			
1	Check operation of Z1 by switching Z1 and Z2.	a. Output current decreases. b. Output current remains high.	a. Z1 defective. b. Check Q19A for open, Q19B for short, Q21 for open, VR10 for short. CR30 open CR27, CR28 shorted.
PART B. LOW OUTPUT CURRENT			
1	Check operation of Z1 by switching Z1 and Z2.	a. Output current increases. b. Output current remains low.	a. Z1 defective. b. Check Q19A for short, Q19B for open, Q21 for short, VR10 for open.

5-48 REPAIR AND REPLACEMENT

5-49 When replacing a defective component, refer to Section VI for component part number and description. Since too much heat could lift the copper circuitry off of a printed circuit board, a low power soldering iron (50 Watts maximum) should be used. Solder suckers make replacement of components easier and cleaner, especially when multi-lead parts are being used; and for this reason, are highly recommended. Use only high quality rosin core solder when repairing printed circuit boards.

5-50 ADJUSTMENT AND CALIBRATION

5-51 Adjustment and calibration may be required after performance testing, troubleshooting, or repair and replacement. If more than one adjustment must be performed, the sequence of adjustments presented in the following paragraphs should be followed.

5-52 METER ZERO

5-53 Proceed as follows to mechanically zero the meter:

- a. Turn off instrument (after it has reached normal operating temperature) and allow 30 seconds for all capacitors to discharge.
- b. Insert sharp pointed object (pen point or awl) into the small indentation near top of round black plastic disc located directly below meter face.
- c. Rotate plastic disc clockwise (cw) until meter reads zero, then rotate ccw slightly in order

to free adjustment screw from meter suspension. If pointer moves, repeat steps (b) and (c).

5-54 AMMETER TRACKING

5-55 The ammeter circuit is adjusted to within $\pm 2\%$, (for full scale readings) at the factory and normally does not require adjustment unless a component in the meter circuit is replaced.

5-56 To calibrate the ammeter, proceed as follows:

- a. Replace any meter circuit jumpers (1 or 2; see schematic) that have been removed previously, at the factory.

- b. Connect test setup of Figure 5-3 (external range switch and medium-low range load resistors can be eliminated, if desired).

- c. Turn VOLTAGE control fully clockwise, set range switch to highest current range, and connect + lead of differential voltmeter to RS1.

- d. Set meter switch to AMPS and adjust CURRENT control until front panel meter reads exactly the maximum rated output current.

- e. Observe reading on differential voltmeter. If it is between 0.981 and 1.019Vdc (Model 6177B) or 2.452 and 2.548Vdc (Model 6181B) leave jumpers 1 and 2 connected and operate normally.

- f. If differential voltmeter reading is between 0.941 and 0.981Vdc (Model 6177B) or 2.345 and 2.452Vdc (Model 6181B) remove jumper number 1 (across R89). Reading should now be within normal limits of step (e).

- g. If differential voltmeter reading is between 0.905 and 0.941Vdc (Model 6177B) or 2.252 and 2.345Vdc (Model 6181B) remove jumper number

2 (across R90). Reading should now be within normal limits of step (e).

h. If differential voltmeter reading is between 0.865 and 0.905Vdc (Model 6177B) or 2.145 and 2.252Vdc (Model 6181B) remove jumpers number one and number two (across R89 and R90). Reading should now be within normal limits of step (e).

5-57 VOLTMETER TRACKING

5-58 The voltmeter is calibrated at the factory, using jumper number 3, and normally does not require adjustment unless the meter is replaced. To calibrate the voltmeter, proceed as follows:

- a. Replace jumper number 3 (across R87) if it was previously removed at the factory.
- b. Connect test setup of Figure 5-3, except connect differential voltmeter between - and guard (A0) terminals.
- c. Turn CURRENT control fully clockwise and set meter switch to VOLTS.
- d. Adjust VOLTAGE control until front panel voltmeter reads exactly the maximum rated output voltage.
- e. If differential voltmeter reading is above 49Vdc (Model 6177B) or 98.1Vdc (Model 6181B) leave jumper number 3 connected and operate normally. If voltmeter reading is below the above indications, remove jumper number 3. Differential voltmeter indication should now be above the aforementioned reading.

5-59 VOLTAGE LIMIT PROGRAMMING ACCURACY AND MAXIMUM OUTPUT VOLTAGE

5-60 This procedure adjusts the voltage limit programming current to within 20% of 1.15mA (Model 6177B) or 2.3mA (Model 6181B). It allows the unit to provide 110% of the maximum rated output voltage despite a 20% resistance tolerance of the front panel VOLTAGE control. This adjustment is necessary only if the VOLTAGE control (R81) is replaced or it can be done as an accuracy check before remote resistance programming of the voltage limit.

5-61 To adjust the programming current, proceed as follows:

- a. Turn CURRENT and VOLTAGE controls fully clockwise.
- b. Connect differential voltmeter across output terminals of supply (positive output terminal grounded).
- c. Connect decade resistance box in place of R6.
- d. Turn on supply and set meter switch to VOLTS. Adjust decade resistance until differential voltmeter reads 110% of the maximum rated output voltage.
- e. Replace decade resistance with appropriate value resistance in R6 position.

5-62 GUARD AMPLIFIER ZERO

5-63 This adjustment minimizes the offset between the bases of the guard input amplifier, Q18. The

offset should be checked and adjusted, if necessary, whenever Q18 is replaced. Proceed as follows to perform this adjustment:

- a. Connect differential voltmeter between rear terminals A1 and A3.
- b. Turn VOLTAGE control fully clockwise.
- c. At any output current, adjust R46 to obtain a $0 \pm 200\mu\text{Vdc}$ reading on differential voltmeter.

5-64 OUTPUT CURRENT ZERO

5-65 To adjust for zero output current, proceed as follows:

- a. Connect test setup of Figure 5-3.
- b. Set range switches to highest current range and connect + lead of differential voltmeter to RS1.
- c. Set meter switch to AMPS and turn CURRENT control fully ccw (minimum).
- d. Adjust R56 to obtain reading on differential voltmeter between 0 and $-200\mu\text{Vdc}$ (Model 6177B) or between 0 and $-500\mu\text{Vdc}$ (Model 6181B).

5-66 CONSTANT CURRENT REMOTE PROGRAMMING ACCURACY

5-67 This procedure adjusts the constant current programming current within the supply. The programming current is factory set to within 1% and should not need adjustment thereafter unless a sampling resistor or reference supply Zener diode (VR5, VR6) is replaced. The programming accuracy can also be checked and adjusted, if required, before remote resistance programming of the unit.

NOTE

To obtain an accurate adjustment, always zero the output current (refer to preceding paragraph) before making this adjustment.

5-68 To adjust the constant current programming accuracy, proceed as follows:

- a. Connect test setup of Figure 5-3.
- b. Turn VOLTAGE control fully clockwise.
- c. Set both range switches to highest current range and connect + lead of differential voltmeter to RS1.
- d. With supply off, unstrap terminals A1 and A2 and connect precision programming resistor between terminals A0 and A1. Resistor value is $2K\Omega$ (Model 6177B) or $5K\Omega$ (Model 6181B); tolerance must be 0.1% minimum.
- e. Connect decade resistance box in R35 position.
- f. Set meter switch to AMPS and adjust decade box to obtain a reading of $1 \pm 0.01\text{Vdc}$ (Model 6177B) or $2.5 \pm 0.025\text{Vdc}$ (Model 6181B) on differential voltmeter.
- g. Turn off supply and replace decade box with appropriate value resistor in R35 position.

SECTION VI REPLACEABLE PARTS

6-1 INTRODUCTION

6-2 This section contains information for ordering replacement parts. Table 6-4 lists parts in alphanumeric order by reference designators and provides the following information:

- a. Reference Designators. Refer to Table 6-1.
- b. Description. Refer to Table 6-2 for abbreviations.
- c. Total Quantity (TQ). Given only the first time the part number is listed except in instruments containing many sub-modular assemblies, in which case the TQ appears the first time the part number is listed in each assembly.
- d. Manufacturer's Part Number or Type.
- e. Manufacturer's Federal Supply Code Number. Refer to Table 6-3 for manufacturer's name and address.
- f. Hewlett-Packard Part Number.
- g. Recommended Spare Parts Quantity (RS) for complete maintenance of one instrument during one year of isolated service.
- h. Parts not identified by a reference designator are listed at the end of Table 6-4 under Mechanical and/or Miscellaneous. The former consists of parts belonging to and grouped by individual assemblies; the latter consists of all parts not immediately associated with an assembly.

6-3 ORDERING INFORMATION

6-4 To order a replacement part, address order or inquiry to your local Hewlett-Packard sales office (see lists at rear of this manual for addresses). Specify the following information for each part: Model, complete serial number, and any Option or special modification (J) numbers of the instrument; Hewlett-Packard part number; circuit reference designator; and description. To order a part not listed in Table 6-4, give a complete description of the part, its function, and its location.

Table 6-1. Reference Designators

A	= assembly	E	= miscellaneous
B	= blower (fan)		electronic part
C	= capacitor	F	= fuse
CB	= circuit breaker	J	= jack, jumper
CR	= diode	K	= relay
DS	= device, signaling (lamp)	L	= inductor
		M	= meter

Table 6-1. Reference Designators (Continued)

P	= plug	V	= vacuum tube, neon bulb, photocell, etc.
Q	= transistor		
R	= resistor	VR	= zener diode
S	= switch	X	= socket
T	= transformer	Z	= integrated circuit or network
TB	= terminal block		
TS	= thermal switch		

Table 6-2. Description Abbreviations

A	= ampere	mfr	= manufacturer
ac	= alternating current	mod.	= modular or modified
assy.	= assembly	mtg	= mounting
bd	= board	n	= nano = 10^{-9}
bkt	= bracket	NC	= normally closed
OC	= degree Centigrade	NO	= normally open
cd	= card	NP	= nickel-plated
coef	= coefficient	Ω	= ohm
comp	= composition	obd	= order by description
CRT	= cathode-ray tube	OD	= outside diameter
CT	= center-tapped	p	= pico = 10^{-12}
dc	= direct current	P.C.	= printed circuit
DPDT	= double pole, double throw	pot.	= potentiometer
DPST	= double pole, single throw	p-p	= peak-to-peak
elect	= electrolytic	ppm	= parts per million
encap	= encapsulated	pvr	= peak reverse voltage
F	= farad	rect	= rectifier
$^{\circ}$ F	= degree Fahrenheit	rms	= root mean square
fxd	= fixed	Si	= silicon
Ge	= germanium	SPDT	= single pole, double throw
H	= Henry	SPST	= single pole, single throw
Hz	= Hertz	SS	= small signal
IC	= integrated circuit	T	= slow-blow
ID	= inside diameter	tan.	= tantalum
incnd	= incandescent	Ti	= titanium
k	= kilo = 10^3	V	= volt
m	= milli = 10^{-3}	var	= variable
M	= mega = 10^6	ww	= wirewound
μ	= micro = 10^{-6}	W	= Watt
met.	= metal		

Table 6-3. Code List of Manufacturers

CODE NO.	MANUFACTURER	ADDRESS
00629	EBY Sales Co., Inc.	Jamaica, N. Y.
00656	Aerovox Corp.	New Bedford, Mass.
00853	Sangamo Electric Co.	
	S. Carolina Div.	Pickens, S. C.
01121	Allen Bradley Co.	Milwaukee, Wis.
01255	Litton Industries, Inc.	Beverly Hills, Calif.
01281	TRW Semiconductors, Inc.	Lawndale, Calif.
01295	Texas Instruments, Inc.	
	Semiconductor-Components Div.	Dallas, Texas
01686	RCL Electronics, Inc.	Manchester, N. H.
01930	Amerock Corp.	Rockford, Ill.
02107	Sparta Mfg. Co.	Dover, Ohio
02114	Ferrocube Corp.	Saugerties, N. Y.
02606	Penwal Laboratories	Morton Grove, Ill.
02660	Amphenol Corp.	Broadview, Ill.
02735	Radio Corp. of America, Solid State and Receiving Tube Div.	Somerville, N. J.
03508	G. E. Semiconductor Products Dept.	Syracuse, N. Y.
03797	Eldema Corp.	Compton, Calif.
03877	Transitron Electronic Corp.	Wakefield, Mass.
03888	Pyrofilm Resistor Co. Inc.	Cedar Knolls, N. J.
04009	Arrow, Hart and Hegeman Electric Co.	Hartford, Conn.
04072	ADC Electronics, Inc.	Harbor City, Calif.
04213	Caddell & Burns Mfg. Co. Inc.	Mineola, N. Y.
04404	*Hewlett-Packard Co. Palo Alto Div.	Palo Alto, Calif.
04713	Motorola Semiconductor Prod. Inc.	Phoenix, Arizona
05277	Westinghouse Electric Corp.	
	Semiconductor Dept.	Youngwood, Pa.
05347	Ultronix, Inc.	Grand Junction, Colo.
05820	Wakefield Engr. Inc.	Wakefield, Mass.
06001	General Elect. Co. Electronic Capacitor & Battery Dept.	Irmo, S. C.
06004	Bassik Div. Stewart-Warner Corp.	Bridgeport, Conn.
06486	IRC Div. of TRW Inc.	
	Semiconductor Plant	Lynn, Mass.
06540	Amatom Electronic Hardware Co. Inc.	New Rochelle, N. Y.
06555	Beede Electrical Instrument Co.	Penacook, N. H.
06666	General Devices Co. Inc.	Indianapolis, Ind.
06751	Semcor Div. Components, Inc.	Phoenix, Arizona
06776	Robinson Nugent, Inc.	New Albany, Ind.
06812	Torrington Mfg. Co., West Div.	Van Nuys, Calif.
07137	Transistor Electronics Corp.	Minneapolis, Minn.

CODE NO.	MANUFACTURER	ADDRESS
07138	Westinghouse Electric Corp.	
	Electronic Tube Div.	Elmira, N. Y.
07263	Fairchild Camera and Instrument Corp. Semiconductor Div.	Mountain View, Calif.
07387	Birtcher Corp., The	Los Angeles, Calif.
07397	Sylvania Electric Prod. Inc.	
	Sylvania Electronic Systems Western Div.	Mountain View, Calif.
07716	IRC Div. of TRW Inc. Burlington Plant	Burlington, Iowa
07910	Continental Device Corp.	Hawthorne, Calif.
07933	Raytheon Co. Components Div. Semiconductor Operation	Mountain View, Calif.
08484	Breeze Corporations, Inc.	Union, N. J.
08530	Reliance Mica Corp.	Brooklyn, N. Y.
08717	Sloan Company, The	Sun Valley, Calif.
08730	Vemaline Products Co. Inc.	Wyckoff, N. J.
08806	General Elect. Co. Minia- ture Lamp Dept.	Cleveland, Ohio
08863	Nylomatic Corp.	Norrisville, Pa.
08919	RCH Supply Co.	Vernon, Calif.
09021	Airco Speer Electronic Components	Bradford, Pa.
09182	*Hewlett-Packard Co. New Jersey Div.	Berkeley Heights, N. J.
09213	General Elect. Co. Semiconductor Prod. Dept.	Buffalo, N. Y.
09214	General Elect. Co. Semiconductor Prod. Dept.	Auburn, N. Y.
09353	C & K Components Inc.	Newton, Mass.
09922	Burndy Corp.	Norwalk, Conn.
11115	Wagner Electric Corp.	
	Tung-Sol Div.	Bloomfield, N. J.
11236	CTS of Berne, Inc.	Berne, Ind.
11237	Chicago Telephone of Cal. Inc.	So. Pasadena, Calif.
11502	IRC Div. of TRW Inc. Boone Plant	Boone, N. C.
11711	General Instrument Corp Rectifier Div.	Newark, N. J.
12136	Philadelphia Handle Co. Inc.	Camden, N. J.
12615	U. S. Terminals, Inc.	Cincinnati, Ohio
12617	Hamlin Inc.	Lake Mills, Wisconsin
12697	Clarostat Mfg. Co. Inc.	Dover, N. H.
13103	Thermalloy Co.	Dallas, Texas
14493	*Hewlett-Packard Co. Loveland Div.	Loveland, Colo.
14655	Cornell-Dubilier Electronics Div. Federal Pacific Electric Co.	Newark, N. J.
14936	General Instrument Corp. Semicon- ductor Prod. Group	Hicksville, N. Y.
15801	Fenwal Elect.	Framingham, Mass.
16299	Coming Glass Works, Electronic Components Div.	Raleigh, N. C.

*Use Code 28480 assigned to Hewlett-Packard Co., Palo Alto, California

Table 6-3. Code List of Manufacturers (Continued)

CODE NO.	MANUFACTURER	ADDRESS
16756	Delco Radio Div. of General Motors Corp.	Kokomo, Ind.
17545	Atlantic Semiconductors, Inc.	Asbury Park, N. J.
17803	Fairchild Camera and Instrument Corp Semiconductor Div. Transducer Plant	Mountain View, Calif.
17870	Daven Div. Thomas A. Edison Industries McGraw-Edison Co.	Orange, N. J.
18324	Signetics Corp.	Sunnyvale, Calif.
19315	Bendix Corp. The Navigation and Control Div.	Teterboro, N. J.
19701	Electra/Midland Corp.	Mineral Wells, Texas
21520	Fansteel Metallurgical Corp.	No. Chicago, Ill.
22229	Union Carbide Corp. Electronics Div.	Mountain View, Calif.
22753	UID Electronics Corp.	Hollywood, Fla.
23936	Pamotor, Inc.	Pampa, Texas
24446	General Electric Co.	Schenectady, N. Y.
24455	General Electric Co. Lamp Div. of Con- sumer Prod. Group	Nela Park, Cleveland, Ohio
24655	General Radio Co.	West Concord, Mass.
24681	LTV Electrosystems Inc Memcor/Com- ponents Operations	Huntington, Ind.
26982	Dynacool Mfg. Co. Inc.	Saugerties, N. Y.
27014	National Semiconductor Corp.	Santa Clara, Calif.
28480	Hewlett-Packard Co.	Palo Alto, Calif.
28520	Heyman Mfg. Co.	Kenilworth, N. J.
28875	IMC Magnetics Corp.	
31514	New Hampshire Div. SAE Advance Packaging, Inc.	Rochester, N. H.
31827	Budwig Mfg. Co.	Santa Ana, Calif.
33173	G. E. Co. Tube Dept.	Ramona, Calif.
35434	Lectrohm, Inc.	Owensboro, Ky.
37942	P. R. Mallory & Co. Inc.	Chicago, Ill.
42190	Muter Co.	Indianapolis, Ind.
43334	New Departure-Hyatt Bearings Div. General Motors Corp.	Chicago, Ill. Sandusky, Ohio
44655	Ohmite Manufacturing Co.	Skokie, Ill.
46384	Penn Engr. and Mfg. Corp.	Doylestown, Pa.
47904	Polaroid Corp.	Cambridge, Mass.
49956	Raytheon Co.	Lexington, Mass.
55026	Simpson Electric Co. Div. of American Gage and Machine Co.	Chicago, Ill.
56289	Sprague Electric Co.	North Adams, Mass.
58474	Superior Electric Co.	Bristol, Conn.
58849	Syntron Div. of FMC Corp.	Homer City, Pa.
59730	Thomas and Betts Co.	Philadelphia, Pa.
61637	Union Carbide Corp.	New York, N. Y.
63743	Ward Leonard Electric Co.	Mt. Vernon, N. Y.

CODE NO.	MANUFACTURER	ADDRESS
70563	Amperite Co. Inc.	Union City, N. J.
70901	Beemer Engrg. Co.	Fort Washington, Pa.
70903	Belden Corp.	Chicago, Ill.
71218	Bud Radio, Inc.	Willoughby, Ohio
71279	Cambridge Thermionic Corp.	Cambridge, Mass.
71400	Bussmann Mfg. Div. of McGraw & Edison Co.	St. Louis, Mo.
71450	CTS Corp.	Elkhart, Ind.
71468	I. T. T. Cannon Electric Inc.	Los Angeles, Calif.
71590	Globe-Union Inc.	
71700	Centralab Div. General Cable Corp. Cornish	Milwaukee, Wis. Williamstown, Mass.
71707	Wire Co. Div.	Williamstown, Mass.
71707	Coto Coil Co. Inc.	Providence, R. I.
71744	Chicago Miniature Lamp Works	Chicago, Ill.
71785	Cinch Mfg. Co. and Howard E. Jones Div.	Chicago, Ill.
71984	Dow Corning Corp.	Midland, Mich.
72136	Electro Motive Mfg. Co. Inc.	Willimantic, Conn.
72619	Dialight Corp.	Brooklyn, N. Y.
72699	General Instrument Corp.	Newark, N. J.
72765	Drake Mfg. Co.	Harwood Heights, Ill.
72962	Elastic Stop Nut Div. of Amerace Esna Corp.	Union, N. J.
72982	Erie Technological Products Inc.	Erie, Pa.
73096	Hart Mfg. Co.	Hartford, Conn.
73138	Beckman Instruments Inc. Helipot Div.	Fullerton, Calif.
73168	Fenwal, Inc.	Ashland, Mass.
73293	Hughes Aircraft Co. Electron Dynamics Div.	Torrance, Calif.
73445	Amperex Electronic Corp.	Hicksville, N. Y.
73506	Bradley Semiconductor Corp.	New Haven, Conn.
73559	Carling Electric, Inc.	Hartford, Conn.
73734	Federal Screw Products, Inc.	Chicago, Ill.
74193	Heinemann Electric Co.	Trenton, N. J.
74545	Hubbell Harvey Inc.	Bridgeport, Conn.
74868	Amphenol Corp. Amphenol RF Div.	Danbury, Conn.
74970	E. F. Johnson Co.	Waseca, Minn.
75042	IRC Div. of TRW, Inc.	Philadelphia, Pa.
75183	*Howard B. Jones Div. of Cinch Mfg. Corp.	New York, N. Y.
75376	Kurz and Kasch, Inc.	Dayton, Ohio
75382	Kilka Electric Corp.	Mt. Vernon, N. Y.
75915	Littlefuse, Inc.	Des Plaines, Ill.
76381	Minnesota Mining and Mfg. Co.	St. Paul, Minn.
76385	Minor Rubber Co. Inc.	Bloomfield, N. J.
76487	James Millen Mfg. Co. Inc.	Malden, Mass.
76493	J. W. Miller Co.	Compton, Calif.

*Use Code 71785 assigned to Cinch Mfg. Co., Chicago, Ill.

Table 6-3. Code List of Manufacturers (Continued)

CODE NO.	MANUFACTURER	ADDRESS
76530	Cinch	City of Industry, Calif.
76854	Oak Mfg. Co. Div. of Oak	
77068	Electro/Netics Corp.	Crystal Lake, Ill.
	Bendix Corp., Electrodynamics Div.	
		No. Hollywood, Calif.
77122	Palnut Co.	Mountainside, N. J.
77147	Patton-MacGuyer Co.	Providence, R. I.
77221	Phaostron Instrument and Electronic Co.	
		South Pasadena, Calif.
77252	Philadelphia Steel and Wire Corp.	
		Philadelphia, Pa.
77342	American Machine and Foundry Co.	
	Potter and Brumfield Div.	Princeton, Ind.
77630	TRW Electronic Components Div.	
		Camden, N. J.
77764	Resistance Products Co.	Harrisburg, Pa.
78189	Illinois Tool Works Inc. Shakeproof Div.	
		Elgin, Ill.
78452	Everlock Chicago, Inc.	Chicago, Ill.
78488	Stackpole Carbon Co.	St. Marys, Pa.
78526	Stanwyck Winding Div.	San Fernando
	Electric Mfg. Co. Inc.	Newburgh, N. Y.
78553	Tinnerman Products, Inc.	Cleveland, Ohio
78584	Stewart Stamping Corp.	Yonkers, N. Y.
79136	Waldes Kohinoor, Inc.	L. I. C., N. Y.
79307	Whitehead Metals Inc.	New York, N. Y.
79727	Continental-Wirt Electronics Corp.	
		Philadelphia, Pa.
79963	Zierick Mfg. Co.	Mt. Kisco, N. Y.
80031	Mepco Div. of Sessions Clock Co.	
		Morristown, N. J.
80294	Bourns, Inc.	Riverside, Calif.
81042	Howard Industries Div. of Msl Ind. Inc.	
		Racine, Wisc.
81073	Grayhill, Inc.	La Grange, Ill.
81483	International Rectifier Corp.	
		El Segundo, Calif.
81751	Columbus Electronics Corp.	Yonkers, N. Y.
82099	Goodyear Sundries & Mechanical Co. Inc.	
		New York, N. Y.
82142	Airco Speer Electronic Components	
		Du Bois, Pa.
82219	Sylvania Electric Products Inc.	
	Electronic Tube Div. Receiving	
	Tube Operations	Emporium, Pa.
82389	Switchcraft, Inc.	Chicago, Ill.
82647	Metals and Controls Inc. Control	
	Products Group	Attleboro, Mass.
82866	Research Products Corp.	Madison, Wis.
82877	Rotron Inc.	Woodstock, N. Y.
82893	Vector Electronic Co.	Glendale, Calif.
83058	Carr Fastener Co.	Cambridge, Mass.
83186	Victory Engineering Corp.	
		Springfield, N. J.
83298	Bendix Corp. Electric Power Div.	
		Eatontown, N. J.
83330	Herman H. Smith, Inc.	Brooklyn, N. Y.
83385	Central Screw Co.	Chicago, Ill.
83501	Gavitt Wire and Cable Div. of	
	Amerace Esna Corp.	Brookfield, Mass.

CODE NO.	MANUFACTURER	ADDRESS
83508	Grant Pulley and Hardware Co.	
		West Nyack, N. Y.
83594	Burroughs Corp. Electronic	
	Components Div.	Plainfield, N. J.
83835	U. S. Radium Corp.	Morristown, N. J.
83877	Yardeny Laboratories, Inc.	
		New York, N. Y.
84171	Arco Electronics, Inc.	Great Neck, N. Y.
84411	TRW Capacitor Div.	Ogallala, Neb.
85684	RCA Corp. Electronic Components	
		Harrison, N. J.
86838	Rummel Fibre Co.	Newark, N. J.
87034	Marco & Oak Industries a Div. of Oak	
	Electro/netics Corp.	Anaheim, Calif.
87216	Philco Corp. Lansdale Div.	Lansdale, Pa.
87585	Stockwell Rubber Co. Inc.	
		Philadelphia, Pa.
87929	Tower-Olschan Corp.	Bridgeport, Conn.
88140	Cutler-Hammer Inc. Power Distribution	
	and Control Div. Lincoln Plant	
		Lincoln, Ill.
88245	Litton Precision Products Inc, USECO	
	Div. Litton Industries	Van Nuys, Calif.
90634	Gulton Industries Inc.	Metuchen, N. J.
90763	United-Car Inc.	Chicago, Ill.
91345	Miller Dial and Nameplate Co.	
		El Monte, Calif.
91418	Radio Materials Co.	Chicago, Ill.
91506	Augat, Inc.	Attleboro, Mass.
91637	Dale Electronics, Inc.	Columbus, Neb.
91662	Elco Corp.	Willow Grove, Pa.
91929	Honeywell Inc. Div. Micro Switch	
		Freeport, Ill.
92825	Whitso, Inc.	Schiller Pk., Ill.
93332	Sylvania Electric Prod. Inc. Semi-	
	conductor Prod. Div.	Woburn, Mass.
93410	Essex Wire Corp. Stemco	
	Controls Div.	Mansfield, Ohio
94144	Raytheon Co. Components Div.	
	Ind. Components Oper.	Quincy, Mass.
94154	Wagner Electric Corp.	
	Tung-Sol Div.	Livingston, N. J.
94222	Southco Inc.	Lester, Pa.
95263	Leecraft Mfg. Co. Inc.	L. I. C., N. Y.
95354	Methode Mfg. Co.	Rolling Meadows, Ill.
95712	Bendix Corp. Microwave	
	Devices Div.	Franklin, Ind.
95987	Weckesser Co. Inc.	Chicago, Ill.
96791	Amphenol Corp. Amphenol	
	Controls Div.	Janesville, Wis.
97464	Industrial Retaining Ring Co.	
		Irvington, N. J.
97702	IMC Magnetics Corp. Eastern Div.	
		Westbury, N. Y.
98291	Sealectro Corp.	Mamaroneck, N. Y.
98410	ETC Inc.	Cleveland, Ohio
98978	International Electronic Research Corp.	
		Burbank, Calif.
99934	Renbrandt, Inc.	Boston, Mass.

Table 6-4. Replaceable Parts

REF. DESIG.	DESCRIPTION	TQ	MFR. PART NO.	MFR. CODE	Ⓢ PART NO.	RS
CHASSIS ELECTRICAL						
DS1	Line Indicator Lamp, Neon	1	A1C	08806	2140-0047	1
DS2	Voltage Limit Indicator Lamp, Incan	1	2187D	08806	2140-0037	1
F1	Fuse Cartridge 3AG 1A 250V	1	312.001	75915	2110-0001	5
J1	Receptacle, Input Power	1		09182	1251-0148	1
M1	Meter, 0-600mA, 0-60V, 2 $\frac{1}{4}$ "	1		09182	1120-1147	1
P1	Power Cord	1	KH-4147	70903	8120-0078	1
Q7, 29, 30	Power NPN Si.	3		09182	1854-0250	3
R40	Current Control, Var. WW 2K Ω \pm 5%, Ten-Turn	1		09182	2100-2029	1
R81	Voltage Control, Var. Cermet 50K Ω \pm 20%	1		09182	2100-2023	1
R93	fxd, comp 47K Ω \pm 5% $\frac{1}{2}$ W	1	EB-4735	01121	0686-4735	1
S1	Line/Meter Switch, Rotary	1		09182	3100-1936	1
S2	Current Range Switch, Rotary	1		09182	3100-1935	1
T1	Transformer, Power	1		09182	5080-7124	1
INPUT P.C. BOARD, 06177-20021						
C1	fxd, elect 500 μ f 150Vdc	1		09182	0180-1889	1
C2	NOT ASSIGNED	-	-	-	-	-
C3	fxd, elect 400 μ f 100Vdc	1		09182	0180-1887	1
C4, 5	fxd, ceramic .05 μ f 500V	2	33617A	56289	0150-0052	1
CR1-8, 29	Rect. Si. 1A 200prv	9	1N5059	03508	1901-0327	6
DS3	Lamp, Incandescent	1	2187D	08806	2140-0037	1
Q8	SS NPN Si.	1	40346	02735	1854-0095	1
R20	fxd, comp 130 Ω \pm 5% $\frac{1}{2}$ W	1	EB-1315	01121	0686-1315	1
R23	fxd, comp 6.8K Ω \pm 5% $\frac{1}{2}$ W	1	EB-6825	01121	0686-6825	1
MAIN P.C. BOARD, 5020-5749						
C6	fxd, elect 5 μ f 150Vdc	1	40D505F150DC4	56289	0180-1841	1
C7	fxd, elect 4.7 μ f 35Vdc	1	150D475X9035B2	56289	0180-0100	1
C8, 9, 15-19, 24, 30, 31, 36-39	NOT ASSIGNED	-	-	-	-	-
C10	fxd, elect 68 μ f @ 15Vdc	1	150D686X0015R2	56289	0180-1835	1
C11	fxd, elect 20 μ f 50Vdc	1	30D206G050CC2	56289	0180-0049	1
C12	fxd, elect .47 μ f 35Vdc	3	150D474X9035A2	56289	0180-0376	1
C13	fxd, ceramic .01 μ f 500V	1	811000V5U0103Z	15450	0150-0081	1
C14	fxd, elect .47 μ f 35Vdc	1	150D474X9035A2	56289	0180-0376	1
C20	fxd, paper .033 μ f 200V	2	192P33392	56289	0160-0163	1
C21	fxd, paper .0047 μ f 200V	2	192P47292	56289	0160-0157	1
C22	fxd, mica 220pf 500V	2	RCM15E221J	15450	0140-0083	1
C23	fxd, mylar .01 μ f 200Vdc	1	192P10390	56289	0160-0161	1
C25	fxd, mylar .1 μ f 200Vdc	2	192P10492	56289	0160-0168	1
C26	fxd, paper .0047 μ f 200V	1	192P47292	56289	0160-0157	1
C27	fxd, mica 220pf 500V	1	RCM15E221J	15450	0140-0083	1
C28	fxd, paper .033 μ f 200V	1	192P33392	56289	0160-0163	1
C29	fxd, elect .47 μ f 35Vdc	1	150D474X9035A2	56289	0180-0376	1
C32	fxd, mylar .1 μ f 200Vdc	1	192P10492	56289	0160-0168	1

REF. DESIG.	DESCRIPTION	TQ	MFR. PART NO.	MFR. CODE	Ⓢ PART NO.	RS
E33	fxd, mica 120pf 300V	1	RDM15F121J3C	84171	0160-2205	1
C34, 35, 40	fxd, elect 1μf 35Vdc	3	150D105X9035A2	56289	0180-0291	1
CR9	Diode, Si. Stabistor 2.4V 100mA	3	1N4830	03508	1901-0460	3
CR10	Rect. Si. 200prv	15	1N485B	93332	1901-0033	7
CR11,19-24, 37,38	NOT ASSIGNED	-	-	-	-	-
CR12	Rect. Si. 200prv	-	1N485B	93332	1901-0033	-
CR13	Rect. Si. 1A 200prv	4	1N5059	03508	1901-0327	4
CR14	Diode, Si. Stabistor 2.4V 100mA	-	1N4830	03508	1901-0460	-
CR15-18, 25-28,30,31	Rect. Si. 200prv	-	1N485B	93332	1901-0033	-
CR32	Diode, Si. Stabistor 2.4V 100mA	-	1N4830	03508	1901-0460	-
CR33	Rect. Si. 200prv	-	1N485B	93332	1901-0033	-
CR34-CR36	Rect. Si. 1A 200prv	-	1N5059	03508	1901-0327	-
CR39, 40	Rect. Si. 200prv	-	1N485B	93332	1901-0033	-
L1	Ferrite Bead	1	56-590-6SA1/3B	02114	9170-0016	1
Q1	Power NPN Si.	2	-	09182	1854-0311	2
Q2,3	SS PNP Si.	3	-	09182	1853-0037	3
Q4	SS NPN Si.	8	2N3391	03508	1854-0071	6
Q5	SS PNP Si.	2	2N2907A	56289	1853-0099	2
Q6	SS PNP Si.	-	-	09182	1853-0037	-
Q9,10,16,17, 23,24	NOT ASSIGNED	-	-	-	-	-
Q11,12	SS PNP Si.	2	40362	02735	1853-0041	2
Q13-Q15	SS NPN Si.	-	2N3391	03508	1854-0071	-
Q18,19	NPN Diff. Amp. Si.	2	2N4045	22229	1854-0221	2
Q20-Q22	SS NPN Si.	-	2N3391	03508	1854-0071	-
Q25	Power NPN Si.	-	-	09182	1854-0311	-
Q26	SS NPN Si.	-	2N3391	03508	1854-0071	-
Q27,28	SS NPN Si.	2	-	09182	1854-0244	2
Q31	SS PNP Si.	-	2N2907A	56289	1853-0099	-
R1	fxd, ww 2Ω ±0.5% 8W 10ppm	1	Type T-7A	01686	0811-2141	1
R2	fxd, ww 18Ω ±0.1% 5ppm	1	Type 7007	01686	0811-2777	1
R3	fxd, ww 180Ω ±0.1% 5ppm	1	Type 7007	01686	0811-2778	1
R4	fxd, comp 5.1KΩ ±5% 2W	1	Type C42S	16299	0698-3644	1
R5	fxd, met. film 4.75KΩ ±1% 1/8W	1	Type CEA T-O	07716	0757-0437	1
R6	fxd, comp (Selected) ±5% 1/2 W	1	Type EB (obd)	01121	-	-
R7	fxd, comp 2.4KΩ ±5% 1/2 W	1	EB-2425	01121	0686-2425	1
R8	fxd, comp 75KΩ ±5% 1/2 W	1	EB-7535	01121	0686-7535	1
R9	fxd, comp 150Ω ±5% 1/2 W	1	EB-1515	01121	0686-1515	1
R10	fxd, comp 3KΩ ±5% 2W	1	Type C42S	16299	0698-3642	1
R11	fxd, comp 100Ω ±5% 1/2 W	2	EB-1015	01121	0686-1015	1
R12	fxd, comp 6.8KΩ ±5% 1/2 W	1	EB-6825	01121	0686-6825	1
R13	fxd, comp 1KΩ ±5% 1/2 W	3	EB-1025	01121	0686-1025	1
R14	fxd, comp 82KΩ ±5% 1/2 W	3	EB-8235	01121	0686-8235	1
R15	fxd, comp 5.6KΩ ±5% 1/2 W	4	EB-5625	01121	0686-5625	1
R16	fxd, comp 1MΩ ±5% 1/2 W	2	EB-1055	01121	0686-1055	1
R17	fxd, comp 1KΩ ±5% 1/2 W	-	EB-1025	01121	0686-1025	-
R18	fxd, comp 750Ω ±5% 1/2 W	2	EB-7515	01121	0686-7515	1
R19	fxd, comp 270Ω ±5% 1/2 W	2	EB-2715	01121	0686-2715	1
R21,24,39, 42-44,50,52, 65-67,69, 82-84	NOT ASSIGNED	-	-	-	-	-
R22	fxd, comp 390Ω ±5% 1/2 W	-	EB-3905	01121	0686-3905	-

REF. DESIG.	DESCRIPTION	TQ	MFR. PART NO.	MFR. CODE	Ⓢ PART NO.	RS
R25	fxd, comp 2K Ω \pm 5% $\frac{1}{2}$ W	1	EB-2025	01121	0686-2025	1
R26,27	fxd, comp 51 Ω \pm 5% $\frac{1}{2}$ W	2	EB-5105	01121	0686-5105	1
R28	fxd, comp 20K Ω \pm 5% $\frac{1}{2}$ W	1	EB-2035	01121	0686-2035	1
R29,30	fxd, met. film 1.5K Ω \pm 1% 1/8W	2	Type CEA T-O	07716	0757-0427	1
R31	fxd, comp 1.8K Ω \pm 5% $\frac{1}{2}$ W	1	EB-1825	01121	0686-1825	1
R32	fxd, comp 2.7K Ω \pm 5% $\frac{1}{2}$ W	1	EB-2725	01121	0686-2725	1
R33	fxd, comp 5.6K Ω \pm 5% $\frac{1}{2}$ W		EB-5625	01121	0686-5625	
R34	fxd, met. film 750 Ω \pm 1% 1/8W	1	Type CEA T-O	07716	0757-0420	1
R35	fxd, ww (Selected) \pm 1%	1	(obd)	-	-	-
R36	fxd, met. film 118K Ω \pm 1% 1/8W	1	Type CEA T-O	07716	0698-3265	1
R37	fxd, ww 11.8K Ω \pm 1%	1	Type 7007	01686	0811-2789	1
R38	fxd, comp 300 Ω \pm 5% 2W	1	Type C42S	16299	0698-3630	1
R41	fxd, comp 82K Ω \pm 5% $\frac{1}{2}$ W		EB-8235	01121	0686-8235	
R45	fxd, met. film 64K Ω \pm 1% 1/8W	4	Type CEA T-9	01686	0698-6275	1
R46	Var. ww 15K Ω \pm 5% 1W	2	Series 100	11502	2100-0896	1
R47	fxd, met. film 64K Ω \pm 1% 1/8W		Type CEA T-9	01686	0698-6275	
R48	fxd, comp 1.5K Ω \pm 5% $\frac{1}{2}$ W	2	EB-1525	01121	0686-1525	1
R49	fxd, comp 6.2K Ω \pm 5% $\frac{1}{2}$ W	1	EB-6225	01121	0686-6225	1
R51	fxd, comp 100 Ω \pm 5% $\frac{1}{2}$ W		EB-1015	01121	0686-1015	
R53,54	fxd, met. film 600 Ω \pm 1% 1/8W	2	Type CEA T-O	07716	0757-1100	1
R55	fxd, met. film 64K Ω \pm 1% 1/8W		Type CEA T-9	01686	0698-6275	
R56	Var. ww 15K Ω \pm 5% 1W		Series 100	11502	2100-0896	
R57	fxd, met. film 64K Ω \pm 1% 1/8W		Type CEA T-9	01686	0698-6275	
R58	fxd, comp 1.5K Ω \pm 5% $\frac{1}{2}$ W		EB-1525	01121	0686-1525	
R59	fxd, comp 390K Ω \pm 5% $\frac{1}{2}$ W	1	EB-3945	01121	0686-3945	1
R60,61	fxd, comp 1.3K Ω \pm 5% $\frac{1}{2}$ W	2	EB-1325	01121	0686-1325	1
R62,63	fxd, met. film 5.49K Ω \pm 1% 1/8W	2	Type CEA T-O	07716	0698-3382	1
R64,68	fxd, comp 5.6K Ω \pm 5% $\frac{1}{2}$ W		EB-5625	01121	0686-5625	
R70	fxd, comp 360 Ω \pm 5% $\frac{1}{2}$ W	1	EB-3615	01121	0686-3615	1
R71	fxd, comp 1K Ω \pm 5% $\frac{1}{2}$ W		EB-1025	01121	0686-1025	
R72	fxd, comp 82K Ω \pm 5% $\frac{1}{2}$ W		EB-8235	01121	0686-8235	
R73	fxd, comp 750 Ω \pm 5% $\frac{1}{2}$ W		EB-7515	01121	0686-7515	
R74-R77	fxd, comp 4.7 Ω \pm 5% $\frac{1}{2}$ W	4	EB-0475	01121	0698-0001	1
R78	fxd, comp 12K Ω \pm 5% $\frac{1}{2}$ W	1	EB-1235	01121	0686-1235	1
R79	fxd, comp 1M Ω \pm 5% $\frac{1}{2}$ W		EB-1055	01121	0686-1055	
R80	fxd, comp 2K Ω \pm 5% 2W	1	Type C42S	16299	0764-0025	1
R85	fxd, met. film 750K Ω \pm 1% 1/8W	1	Type CEA T-O	07716	0757-0420	1
R86	fxd, met. film 330 Ω \pm 1% 1/8W	1	Type CEA T-O	07716	0698-5663	1
R87	fxd, met. film 43K Ω \pm 1% $\frac{1}{4}$ W	1	Type CEB T-O	07716	0698-5090	1
R88	fxd, comp 1.5M Ω \pm 5% $\frac{1}{2}$ W	1	EB-1555	01121	0686-1555	1
R89	fxd, comp 16 Ω \pm 5% $\frac{1}{2}$ W	1	EB-1605	01121	0698-3561	1
R90	fxd, comp 27 Ω \pm 5% $\frac{1}{2}$ W	1	EB-2705	01121	0686-2705	1
R91	fxd, met. film 42.2 Ω \pm 1% 1/8W	1	Type CEA T-O	07716	0757-0316	1
R92	Thermistor, 64 Ω \pm 10%	1		09182	0837-0023	1
VR1,2	Diode, Zener 6.19V 400mW	2	1N753	04713	1902-0049	2
VR3,8,9,11	NOT ASSIGNED	-	-	-	-	-
VR4	Diode, Zener 5.6V 400mW	3	1N755	04713	1902-3104	3
VR5	Diode, Zener 6.2V 250mW	1	1N825	03877	1902-1221	1
VR6	Diode, Zener 16.2V 400mW	1	1N966	04713	1902-0184	1
VR7	Diode, Zener 5.6V 400mW		1N755	04713	1902-3104	
VR10	Diode, Zener 2.37V 400mW	1	1N4370	04713	1902-3002	1
VR12	Diode, Zener 5.6V 400mW		1N755	04713	1902-3104	
VR13	Diode, Zener 6.19V \pm 5%	1		09182	1902-0049	1
VR14	Diode, Zener 42.2V 400mW	1	1N976	04713	1902-3323	1
VR15	Diode, Zener 20.5V 400mW	1	1N968	04713	1902-0182	1
Z1,2	Integrated Circuit, Op. Amplifier	2	LM709C	12040	1820-0038	2

REF. DESIG.	DESCRIPTION	TQ	MFR. PART NO.	MFR. CODE	PART NO.	RS
	MISCELLANEOUS					
	Chassis, Center	1		09182	5000-6230	
	Panel, Rear	1		09182	5000-6231	
	Heat Sink, Rear Panel	1		09182	5020-5752	
	Panel, Front, Complete	1		09182	06177-60002	
	Front Panel, Basic	1		09182	5020-5753	
	Front Panel, Top Insert	1		09182	06177-60003	
	Front Panel, Bottom Insert	1		09182	06177-60004	
	Knob Assembly, R40, R81	2		09182	0370-0846	2
	Knob Assembly, S1, S2	2		09182	0370-0844	2
	Front Panel Binding Post, Black	1	DF21BLK	58474	1510-0039	1
	Front Panel Binding Post, Maroon	1	DF21MN	58474	1510-0040	1
	Front Panel Binding Post, White	1	DF21WTC	58474	1510-0067	1
	Front Panel Binding Post, Green	1	DF21GNC	58474	1510-0066	1
	Shoulder Washer, Front Panel Terminals	4	100350	82455	2190-0494	4
	Meter Bezel, 1/6 Mod.	1		09182	4040-0295	1
	Meter Spring	4		09182	1460-0720	2
	Lampholder, Clear, DS1-DS2	2		09182	5040-0234	1
	Lampholder, Base, DS1-DS2	2		09182	5040-0305	1
	Frame Assembly, Side	2		09182	5060-0700	
	Spacer, Side Frame Assembly	2		09182	5020-0701	
	Cover, Side	2		09182	5000-0700	
	Cover, Top	1		09182	5060-0724	
	Cover, Bottom	1		09182	5000-0719	
	Stand, Tilt	1		09182	1490-0032	
	Foot Assembly	2		09182	5060-0728	
	Hinge, Foot Assembly	2		09182	5040-0700	
	Fastener, Covers	4		09182	0590-0052	1
	Chassis Terminal Strip, Input Power	1	332-14-05-034	71785	0360-1187	1
	Shoulder Washer, Rear Heat Sink	4		09182	0340-0172	1
	Cable Clamp	3		09182	1400-0116	1
	Bushing Insulator, Base-Emitter Q7,29,30	6		09182	0340-0166	6
	Bushing Insulator, Collector Screws Q7, Q29, and Q30	6		09182	0340-0170	6
	Insulator, Boron Nitride, Q7, Q29, Q30	3	H4001	42451	0340-0411	3
	Spacer, Q25 Collector	2		09182	0380-0716	2
	Fuseholder Assembly	1	342014	75915	1400-0084	1
	Hex Nut, Fuseholder	1	90312	75915	2950-0038	1
	Lockwasher, Fuseholder	1		09182	2190-0037	1
	Flat Neoprene Washer, Fuseholder	1	901-2	75915	1400-0090	1
	Barrier Strip, 5-Terminal	1		09182	0360-1550	1
	Barrier Strip, 4-Terminal	1		09182	0360-1551	1
	Jumper, Barrier Strip	3	422-13-11-013	71785	0360-1143	1
	Cover, Barrier Strip	1		09182	5020-5755	1
	Main P.C. Board, Includes Components	1		09182	06177-60022	
	Shoulder Washer, Insulated	6		09182	2190-0490	6
	Socket, Z1-Z2	2	133-98-92-061	71785	1200-0763	2
	Standoff, Main P.C. Board, 1/4" Hex	2		09182	0380-0173	1
	Input P.C. Board, Includes Components	1		09182	06177-60021	
	Indian Bead, Q2	1		09182	4330-0145	1
	Standoff, Input P.C. Board, 1/4" Hex	2		09182	0380-0175	1
	Carton, Packing	1		09182	9211-0848	
	End Caps, Packing	2		09182	9220-1218	
	Filler Pad, Packing	1		09182	9220-1237	
	OPTION 14					
	3 Digit Decadial Current Control					
	3 Digit Decadial	1	RD411	07716	1140-0020	1
	Flat Washer (Mod.)	1		09182	06177-00006	1

APPENDIX A MANUAL BACKDATING CHANGES

In some cases, component values and part numbers have changed from some previous part listed in an earlier manual to the present part listed in Section VI of this manual. Generally these changes have been affected to improve the operation of the supply. In most cases, when ordering new parts, the components and part numbers list-

ed in Section VI of this manual should be used as a replacement for any defective part. Where applicable, a separate change page is included with the manual which lists the most recent changes. In this case the component(s) listed on the change page should be used as the replacement part.

SECTION VII CIRCUIT DIAGRAMS

This section contains the circuit diagrams necessary for the operation and maintenance of this power supply. Included are:

- a. Component Location Diagrams, Figures 7-1 and 7-2, which show the physical location and reference designator of parts mounted on the printed wiring board.
- b. Schematic Diagram, Figure 7-3, which illustrates the circuitry for the entire power supply. Voltages are given adjacent to test points, identified by encircled numbers on the schematic.

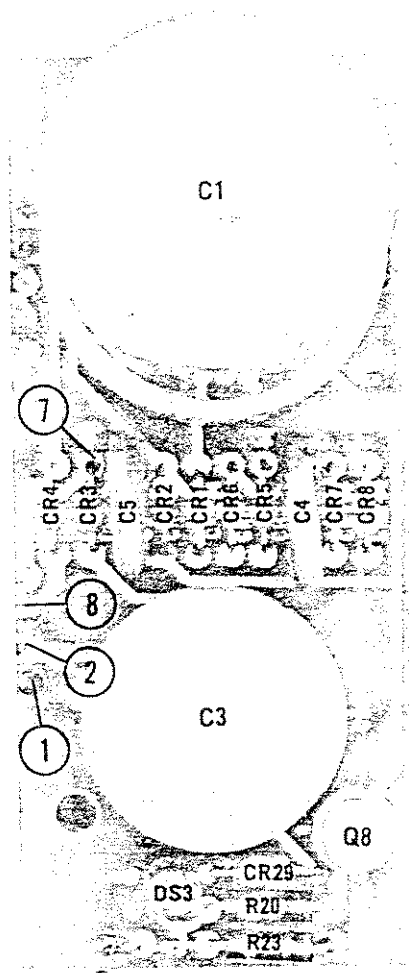

Figure 7-1. Input Printed Circuit Board Component Location