

Errata

This manual may contain references to HP or Hewlett-Packard. Please note that Hewlett-Packard's former test and measurement, semiconductor products and chemical analysis businesses are now part of Agilent Technologies. To reduce potential confusion, the only change to product numbers and names has been in the company name prefix: where a product number/name was HP XXXX the current name/number is now Agilent XXXX. For example, model number HP8648 is now model number Agilent 8648.

Ce manuel peut contenir des références à <<HP>> ou <<Hewlett-Packard.>> Veuillez noter que les produits de test et mesure, de semi-conducteur et d'analyse chimique qui avaient fait partie de la société Hewlett-Packard sont maintenant une partie de la société Agilent Technologies. Pour réduire la confusion potentielle, le seul changement aux noms de référence a été dans le préfixe de nom de société : là où un nom de référence était HP XXXX, le nouveau nom de référence est maintenant Agilent XXXX. Par exemple, le HP 8648 s'appelle maintenant Agilent 8648.

Diese Gebrauchsanweisung kann Bezug nehmen auf die Namen HP oder Hewlett-Packard. Bitte beachten Sie, dass ehemalige Betriebsbereiche von Hewlett-Packard wie HP-Halbleiterprodukte, HP-chemische Analysen oder HP-Test- und Messwesen nun zu der Firma Agilent Technology gehören. Um Verwirrung zu vermeiden wurde lediglich bei Produktname und - Nummer der vor laufende Firmenname geändert: Produkte mit dem Namen/Nummer HP XXXX lauten nun mehr Agilent XXXX. Z.B. das Modell HP 8648 heißt nun Agilent 8648.

Questo manuale potrebbe contenere riferimenti ad HP o Hewlett-Packard. Si noti che le attività precedentemente gestite da Hewlett-Packard nel campo di Test & Misura, Semiconduttori, ed Analisi Chimica sono ora diventate parte di Agilent Technologies. Al fine di ridurre il rischio di confusione, l'unica modifica effettuata sui numeri di prodotto e sui nomi ha riguardato il prefisso con il nome dell'azienda : dove precedentemente compariva "HP XXXX" compare ora "Agilent XXXX". Ad esempio: il modello HP8648 è ora indicato come Agilent 8648.

Este manual puede hacer referencias a HP o Hewlett Packard. Las organizaciones de Prueba y Medición (Test and Measurement), Semiconductores (Semiconductor Products) y Análisis Químico (Chemical Analysis) que pertenecían a Hewlett Packard, ahora forman parte de Agilent Technologies. Para reducir una potencial confusión, el único cambio en el número de producto y nombre, es el prefijo de la compañía: Si el producto solía ser HP XXXX, ahora pasa a ser Agilent XXXX. Por ejemplo, el modelo HP8648 es ahora Agilent 8648.

这个手册里面可能含有惠普公司的资料。请注意惠普公司以前的测试, 半导体产品, 化学分析部门现在属于安捷伦公司。为了减少可能的误解, 产品号码和名字只改变最前面的公司名字。如果一个产品的号码/名字以前是HP XXXX, 现在的号码/名字是安捷伦 XXXX。例如模型号码是惠普8648。现在是模型号码安捷伦8648。

Document Part Number 08478-90015
Printed in the US November 1981



Agilent Technologies

マニュアル・チェンジ

変更

本文中の「HP (YHP)」、または「(横河)ヒューレット・パッカー株式会社」という語句を、「Agilent」、または「アジレント・テクノロジー株式会社」と変更してください。

ヒューレット・パッカー社の電子計測、半導体製品、化学分析ビジネス部門は分離独立し、アジレント・テクノロジー社となりました。

社名変更に伴うお客様の混乱を避けるため、製品番号の接頭部のみ変更しております。

(例: 旧製品名 HP 4294A は、現在 Agilent 4294A として販売いたしております。)

8478B THERMISTOR MOUNT



NOVEMBER 1981

 **HEWLETT
PACKARD**

GENERAL INFORMATION

1. INTRODUCTION

2. The HP Model 8478B Coaxial Thermistor Mount is designed for use with HP Model 431 and 432 Power Meters to measure microwave power from $1 \mu\text{W}$ to 10 mW. Design of the mount minimizes adverse effects from environmental temperature changes during measurement. For increased measurement accuracy, Effective Efficiency and Calibration Factor are measured for each mount at selected frequencies across the operating range; the results are marked on the label of the instrument (see Paragraph 40). The Model 8478B can be used over the 10 MHz to 18 GHz frequency range. Throughout the range, the mount terminates the coaxial input in a 50-ohm impedance, and has a SWR of not more than 1.75 without external tuning.

3. Each mount contains two series pairs of thermistors, which are matched to cancel the effects of drift with ambient temperature change. Thermal stability is accomplished by mounting the leads of all four thermistors on a common thermal conductor to ensure a common thermal environment. This conductor is thermally insulated from the main body of the mount so the thermal noise or shocks applied externally to the mount, such as those from handling the mount manually, cannot significantly penetrate to disturb the thermistor. This thermal immunity enables the thermistors to be used in the measurement of microwave power down to the microwatt region.

4. The 8478B operates directly with 431C and 432 Power Meters. Model 11527A adapter is used for operation with 431A/B Power Meters. Model 11528A is used for operation with 430 Power Meters.

5. SPECIFICATIONS

6. The specifications are listed in Table 1. These specifications are the performance standards against which the Thermistor Mount/Power Meter operation is compared.

7. For operation with the 431 Power Meter, add the following uncertainties to those indicated in Table 1: for 0.3 mW range, $\pm 0.3\%$; for 0.1 mW range, $\pm 0.7\%$; for 0.03 mW range, $\pm 1.5\%$; for 0.01 mW range, $\pm 2.8\%$. The power range in which the 431/8478B operates is $1 \mu\text{W}$ to 10 mW.

8. INSTRUMENTS COVERED BY MANUAL

9. This manual applies directly to instruments with serial numbers prefixed 2106A. With the backdating found in Appendix A, the manual also applies to instruments with serial numbers prefixed 2030A and below.

10. INCOMING INSPECTION

11. Inspect the Model 8478B upon receipt for mechanical damage. Also check it electrically; if the mount was subjected to severe mechanical shock during shipment, the match between the thermistors may be affected. To check thermistor match, proceed as described in Paragraph 71.

12. If any damage is found, inform the carrier and your nearest HP Sales and Service office immediately.

OPERATION

13. PRECAUTIONS

14. Mechanical Shock

CAUTION

DO NOT SUBJECT THE MOUNT TO MECHANICAL SHOCK. Shock may destroy the match between thermistors and increase susceptibility to drift.

15. Biasing Thermistors

CAUTION

Before connecting the 8478B to a 431C or 432-series Power Meter, set the MOUNT RES switch to the 200 Ω position. For Mounts with serial numbers prefixed below 1833A, set the MOUNT RES switch to 200 Ω BAL (431) or 200 Ω (432). When using the 8478B with a 431A/B or 430 Power Meter, use Model 11527A or 11528A Adapter respectively and set MOUNT RES switch to 200 Ω position. Connecting a 200-ohm mount to a power meter set for a 100-ohm mount can result in thermistor damage.

Table 1. Specifications

SPECIFICATIONS

Frequency Range: 10 MHz to 18 GHz.

Uncertainty of Calibration Factor Data

Frequency (GHz)	Sum of Uncertainties ¹	Probable Uncertainty ²
2.0	±2.60%	±1.60%
3.0	±2.60%	±1.60%
4.0	±2.70%	±1.60%
5.0	±2.70%	±1.60%
6.0	±2.70%	±1.60%
7.0	±2.70%	±1.60%
8.0	±3.10%	±1.80%
9.0	±3.30%	±1.80%
10.0	±3.40%	±2.00%
11.0	±3.60%	±2.00%
12.4	±3.70%	±2.20%
13.0	±3.70%	±2.20%
14.0	±4.00%	±2.20%
15.0	±4.00%	±2.50%
16.0	±4.40%	±2.50%
17.0	±5.20%	±3.20%
18.0	±5.10%	±3.20%

¹Includes uncertainty of reference standard and transfer uncertainties. Directly traceable to NBS.

²Square root of the sum of the squares of the individual uncertainties (RSS).

Input Impedance: 50 ohms.

Operating Resistance: 200 ohms, unbalanced.

Power Range with Model 432: 1 μW to 10 mW.

Maximum Peak Power: 200W.

Maximum Average Power: 30 mW.

Maximum Energy per Pulse: 10 W-μs for a PRF ≥ 1 kHz; 5 W-μs for a PRF < 1 kHz.

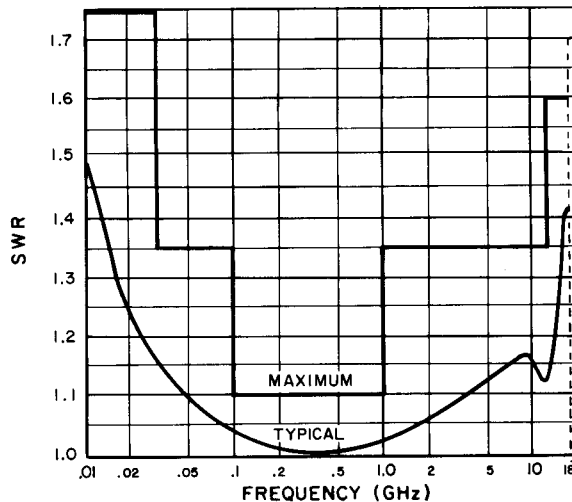

SWR Limits

Maximum Reflection Coefficient:

10 to 30 MHz: 0.273 (1.75 SWR, 11.3 dB return loss).

30 MHz to 100 MHz: 0.15 (1.35 SWR, 16.5 dB return loss).

100 MHz to 1 GHz: 0.048 (1.1 SWR, 26.4 dB return loss).

1 to 12.4 GHz: 0.15 (1.35 SWR, 16.5 dB return loss).

12.4 to 18 GHz: 0.230 (1.6 SWR, 12.8 dB return loss).

Elements: Thermally balanced thermistor assembly. Thermistor assembly is field adjustable so that full zero-set capability can be restored in the event of inadvertent overload.

RF Connector: Stainless steel type N male (APC-7 also available — see Option 11 below).

Output Connector: Mates with power meter cable (operates directly with 432).

Weight: Net 140 g (5 oz).

Option 11: 8478B Thermistor Mount supplied with APC-7 RF connector.

16. Maximum Input

CAUTION

The Model 8478B/431 and 8478B/432 combinations respond to the average RF power applied. The maximum signal applied to the thermistor mount should not exceed the limitations for 1) average power, 2) pulse energy, and 3) peak pulse power. Excessive input can permanently damage the Model 8478B by altering the match between the RF and compensation thermistors (resulting in excessive drift or zero shift) or cause error in indicated power.

17. Average Power

CAUTION

UNDER NO CIRCUMSTANCES APPLY MORE THAN 30 mW AVERAGE POWER TO THE MOUNT. The 8478B/431 and 8478B/432 combinations can measure average power up to 10 mW (ranges 1 μ W to 10 mW). To measure power in excess of 10 mW, insert a calibrated directional coupler such as one of the HP Model 790 series or one of the 8491 series coaxial attenuators between the mount and the source.

18. Pulse Energy and Peak Power for 8478B/432 Combination

CAUTION

For pulses shorter than 250 μ s, energy per pulse must not exceed 10 W- μ s and peak power should never exceed 200 watts. (For example, a 40 mW, 250 μ s pulse contains 10 W- μ s of energy.) Pulses longer than 250 μ s are allowed to contain more energy but peak power must not exceed 200 watts. Figures 1 and 2 interpret these limits in graphical form. (For lack of space, the mount nameplate lists only a 5 W- μ s limit, a rating which applies to the 8478B/432A combination.)

19. Pulse Energy and Peak Power for 8478B/431 Combination

20. The limitations of this combination are basically the same as the 8478B/432 with the excep-

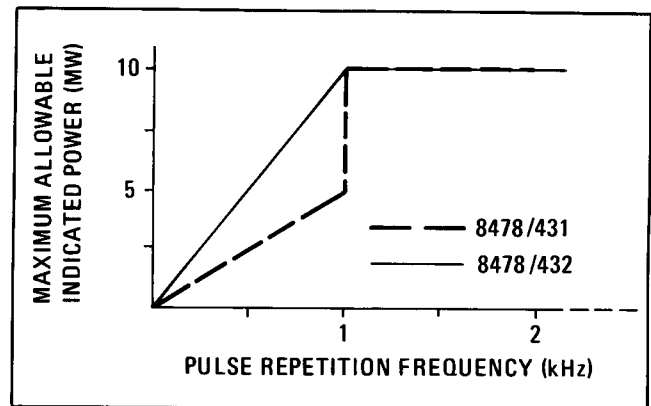

Figure 1. Maximum Power Meter Reading vs PRF for Pulses Shorter than 250 μ s

tion that at pulse repetition rates less than 1 kHz, energy per pulse must not exceed 5 W- μ and peak power must not exceed 10 mW. These limits are also interpreted in Figures 1 and 2.

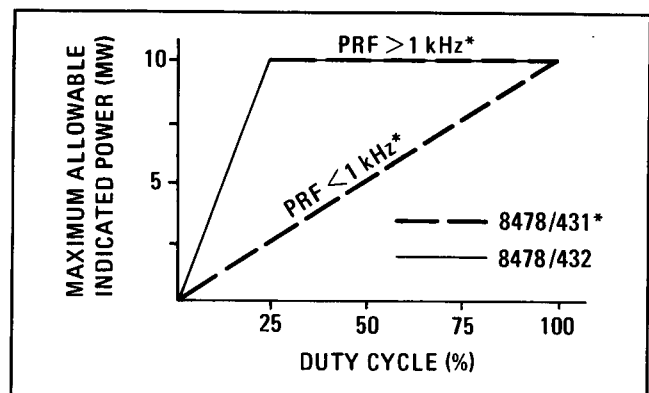

Figure 2. Maximum Power Meter Reading vs Duty Cycle for Pulses Longer than 250 μ s

21. Square-wave modulation is a special case of pulse modulation, and maximum power-meter reading versus square-wave frequency is illustrated in Figure 3. This figure also holds for sine-wave modulation.

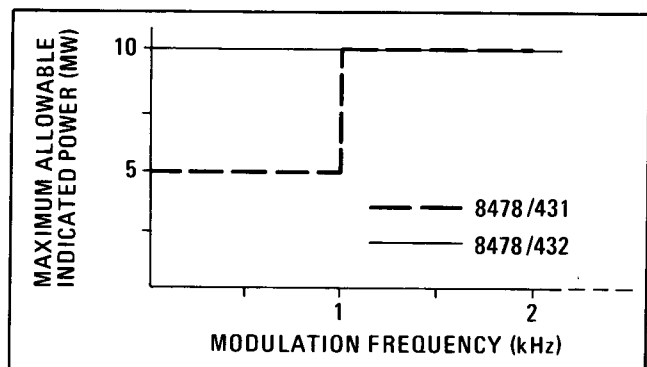

Figure 3. Maximum Power Meter Reading vs Square and Sine-Wave Frequency

22. In the discussions above, the primary consideration is maximum power or energy. However, for modulation frequencies less than 100 Hz, the low repetition frequency itself causes errors in indicated power. These errors may be as large as two percent regardless of range or reading.

23. When RF is switched by pulse-gating (coaxial solid state switches), consideration must be given to the RF energy contained in the switching pulse itself. This energy must be added to actual RF pulse power when estimating the RF power dissipated in the thermistor mount. PIN diode modulators of HP Model 8741A/8716A Modulators and 8614A/8616A Signal Generators, however, are not subject to this consideration because output filtering prevents transmission of modulating signals.

24. DRIFT PRECAUTION

25. Thermistors are inherently temperature-sensitive devices. A cold thermistor mount connected to a warm piece of equipment, or vice versa, produces rapid drift. FOR MINIMUM DRIFT on sensitive ranges, make sure that the mount and the equipment connected to it are at nearly the same temperature before making a measurement.

26. Operation with 431A/B/C or 430 Power Meters

27. If the 8478B is used with a 430 Power Meter, a Model 11528A Adapter is required.

28. Because the mount is unbalanced, a large amount of 10 kHz audio bias signal may be coupled from the power meter to the RF source output. The RF source 10 kHz output impedance forms a parallel circuit shunt across one of the detection thermistor elements. If the RF source presents a 10 kHz impedance of 15kohms or greater, the audio bias voltage appearing at the RF input connection is typically 1.3 Vrms. For an RF source 10 kHz impedance of 50 ohms, the audio bias voltage is greatly reduced to typically 5 mV rms. The presence of a large 10 kHz audio bias voltage at the RF source output may affect solid state RF sources and RF voltmeter measurements. To minimize or eliminate these effects, use a high-pass filter at the RF source output.

29. A variation in 10 kHz impedance at the RF input connection affects the power meter RF detection bridge circuit. This causes a shift in the power meter zero setting. Refer to the following paragraphs for the proper power meter zero procedure.

30. ZERO-SET

31. It is necessary to electrically zero-set the Power Meter before making a power measurement. To preserve the same zero reference throughout the measurement, maintain the same thermal environment when RF power is applied. Recommended setups for 430 and 431 zero-settings are presented in Paragraphs 34 and 36. The recommended setup for zero-set in the 432 is shown in Paragraph 38.

32. RF Power Turned Off for Zero-Set

33. There is minimum zero drift when the zero is set with the RF system connected to the thermistor mount and the RF power switch off or greatly attenuated by the generator attenuator. After allowing time for the mount to stabilize thoroughly, follow zero-set procedures in the Power Meter manual.

34. Unbalanced Operation with Model 431A/B/C and 430 Power Meters

35. When the RF source presents a high 10 kHz output impedance of 100k ohms or greater, the power meter may be zeroed with the 8478B disconnected from the RF source and unterminated as explained in the previous paragraph. If the RF source presents a low 10 kHz impedance of 1k ohm or less, a zero setting made with the 8478B disconnected from the RF source and unterminated will not be the proper zero setting for power measurement. This error can be eliminated by terminating the 8478B in an impedance that approximates the RF source impedance at 10 kHz while zeroing the power meter. For example, if the RF source 10 kHz impedance is 50 ohms, terminate the RF input connection to the 8478B with a 50 ohm resistor.

36. Balanced Operation with Model 431C Power Meter

37. When using a balanced mount, if it is inconvenient to turn off RF power in the RF source, connect the 8478B to the RF source and set 431C Power Meter RANGE switch to obtain an approximate midscale reading. When the reading does not drift, disconnect the 8478B from the source, zero the power meter, and immediately reconnect the mount to the RF source for the power measurement.

38. 8478B/432

39. When it is inconvenient to turn the RF power off while using the 8478B/432 combination simply remove the mount from the source, and using the COARSE and FINE ZERO, zero the 432.

40. MOUNT CALIBRATION DATA

41. The calibration points imprinted on the label of each 8478B allow power measurements to be made with increased accuracy. Values of Calibration Factor and Effective Efficiency are given at seven frequencies between 10 MHz and 18 GHz. The mounts are tested on a swept-frequency basis to assure accurate interpolation between calibration points. Calibration Factor and Effective Efficiency values are traceable to the National Bureau of Standards to the extent allowed by the Bureau's calibration facilities.

42. Calibration Factor

43. Calibration Factor is the ratio of substituted audio or dc power in a thermistor mount to the microwave RF power incident upon the mount.

$$\text{Calibration Factor} = \frac{P_{\text{dc}} \text{ Substituted}}{P_{\mu\text{wave}} \text{ Incident}}$$

44. Calibration Factor is a figure of merit assigned to a thermistor mount to correct for the following sources of error: 1) RF reflected by the mount due to mismatch, 2) RF loss caused by absorption within the mount but not in the detection thermistor elements, and 3) dc-to-microwave power substitution error. Calibration Factor is applied as a correction factor to all measurements made without a tuner. When these factors and thermoelectric effect (refer to Paragraph 54) are taken into consideration, the power indicated is the power that would be delivered by the RF source to the characteristic impedance of the transmission line. The total SWR in the transmission line determines a region of uncertainty about the measured power. This subject is discussed in Application Note 64-1, available from any Hewlett-Packard Sales and Service office.

45. Effective Efficiency

46. Effective Efficiency is the ratio of substituted audio or dc power in a thermistor mount to the microwave RF power dissipated within the mount.

$$\text{Effective Efficiency} = \frac{P_{\text{dc}} \text{ Substituted}}{P_{\mu\text{wave}} \text{ Dissipated}}$$

47. Effective Efficiency corrects for power absorbed in parts of the mount other than the detection thermistor elements and dc-to-microwave power substitution error in the thermistor mount. Effective Efficiency is applied as a correction factor when a tuner is used to match the thermistor

mount to the transmission line or RF source. In this case, all of the RF power incident upon the mount is absorbed in the mount. Since all power is absorbed in the mount, measurement uncertainty due to mount SWR is eliminated; however, losses in the tuner must be considered.

48. CALIBRATION DATA APPLICATION

49. When the 8478B is used with the Model 431 or 432 Power Meters, Calibration Factor or Effective Efficiency corrections can be made by setting a front panel switch. With the proper setting, the 431 or 432 compensates for the Calibration Factor or Effective Efficiency in the 8478B. If the 8478B is used with a power meter other than the 431 or 432, Calibration Factor or Effective Efficiency corrections can be made by dividing the measured power by the Calibration Factor or Effective Efficiency value respectively.

50. THERMOELECTRIC EFFECT

51. When using 431 Power Meters, thermoelectric errors must be taken into consideration. Mount calibration uncertainties given in Table 1 include inaccuracies caused by thermoelectric effect error. Calibration Factor uncertainty of $\pm 1.5\%$ and Effective Efficiency uncertainty of $\pm 2.5\%$ can be maintained on the three lowest power ranges of the Model 431 series Power Meters by correcting for the measurement error introduced by thermoelectric effect. An error correction procedure is given in Paragraph 54.

52. A mild thermocouple exists at each point of contact where the connecting wires join to the thermistor elements. Each thermocouple creates a dc voltage. Thus, two thermocouple voltages of opposite relative polarity are formed, one at each junction to each thermistor element.

53. Ideally, each thermocouple voltage would be equal in magnitude so that they cancel with no resultant effect on the accuracy of power measurement. In practice, however, each point of contact does not have identical thermocouple characteristics, and in addition, the temperatures at each junction may not be the same. These differences cause an incomplete cancellation of the thermoelectric voltages, resulting in a voltage that causes a thermoelectric effect error. The magnitude of the error is important when making dc substitution measurements on the 0.1 mW, 0.03 mW, and 0.01 mW ranges with one of the Model 431 series Power Meters. On other ranges, the effect is negligible.

Maximum error introduced by thermoelectric effect is about $0.3 \mu\text{W}$ and is typically $0.1 \mu\text{W}$ on the 0.01 mW range. Refer to Paragraph 7.

54. Thermoelectric Effect Error Correction for 8478B/431 Combination.

55. Use the following technique to correct for thermoelectric effect error.

- a. Measure power.
- b. Connect a HP Model 8402B Power Meter Calibrator to the power meter DC CALIBRATION AND SUBSTITUTION connector.
- c. Zero and null power meter.
- d. By dc substitution (refer to procedure in 431 Manual), duplicate power measurement made in step a. Calculate and record substituted power as P_1 .
- e. Reverse connection polarity between the calibrator and power meter.
- f. Re-zero and re-null power meter, if necessary.
- g. By dc substitution, duplicate lower measurement made in step a. Calculate and record substituted power as P_2 .
- h. Calculate arithmetic mean of the two substitution powers P_1 and P_2 . This mean power includes a correction for thermoelectric effect error.

$$\text{Power} = \frac{P_1 + P_2}{2}$$

56. Thermoelectric Error for 8478B/432 Combination

57. The thermoelectric errors present in the 431 are minimized in the 432 since the thermoelectric voltage is negligible compared with the dc voltage used to bias the thermistor bridges.

OPERATING PRINCIPLES

58. GENERAL OPERATION

59. Two matched pairs of thermistor elements are used in the 8478B. Each pair is connected in series and the two pairs are mounted in a common thermal conducting block. The thermistor pairs are used in the bridges of the power meter. One pair,

the detection thermistors, is used as an arm of the RF detection bridge. The other pair, the compensation thermistors, is used as an arm of the compensation and metering bridge.

60. **Operation with 432 Power Meter.** With the 8478B attached to the 432 Power Meter the detection thermistors are part of the RF bridge and the compensation thermistors are part of the compensation bridge. Since the two pairs of thermistors show the same thermal environment, any change in temperature which affects the RF bridge simultaneously affects the metering bridge; this allows the power meter circuit to compensate for changes in temperature and thus minimize drift.

61. During operation sufficient amounts of dc current are supplied from 432 Power Meter to heat the thermistors until their resistances are reduced to approximately 200Ω per series pair. Capacitor C1 is practically a short to RF. This causes "D" to appear series connected to the dc bridge, parallel connected to RF. In this manner, "D" appears to the dc bridge in the 432 Power Meter as a 200Ω resistance that terminates the coaxial cable into 50Ω . Capacitor C1 blocks any dc and audio power that may be present in the incoming signal and passes only RF power.

62. **Operation with 431 Power Meter.** The RF detection bridge balance is affected by RF power input to the 8478B, and the bridge is balanced by the application of 10 kHz audio bias power. The compensation and metering bridge is indirectly, but equally affected, by the application of RF power. Deviation from a near-balance condition is caused by an equal change in the 10 kHz audio bias power to the compensation thermistor pair, as initiated by the RF detection bridge. The compensation and metering bridge is returned to near-balance by the application of dc power.

63. During 8478B/431 operation, sufficient amounts of dc and 10 kHz bias currents are supplied from the 431 Power Meter to heat the thermistors until their resistances are reduced to approximately 200Ω per series pair. Capacitor C3 offers high impedance to 10 kHz , but is practically a short to RF. This causes "D" to appear series connected to 10 kHz , but parallel connected to RF. In this manner, "D" appears to the audio bridge of the 431 Power Meter as a 200Ω resistance, but terminates the coaxial cable in 50Ω . Capacitor C1 blocks any dc and audio power that may be present in the incoming signal, and passes only RF power.

64. 432 Power Detection

65. Under normal operation, the total power applied to heat thermistor pair "D" (see Figure 4) consists of: 1) RF signal, 2) heat from the environment, and 3) dc bias. The total power supplied to heat thermistor "C" consists of: 1) dc bias, and 2) heat from the same environment. As "D" and "C" are matched thermally, the total amounts of heat applied to reduce their series resistance equally must be equal.

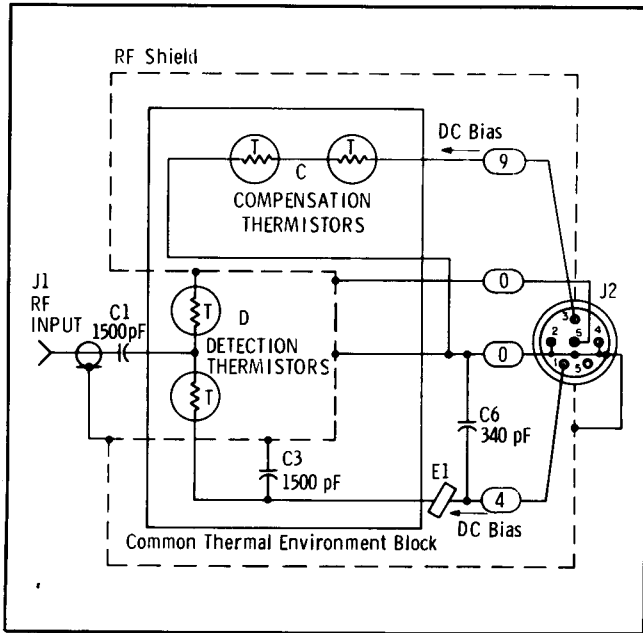

Figure 4. 8478B Connected to a 432A Power Meter

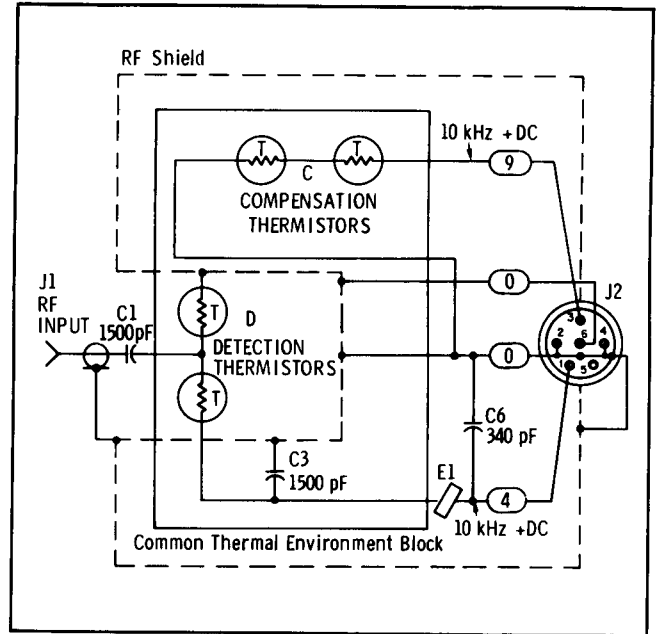

Figure 5. 8478B Connected to a 431C Power Meter

MAINTENANCE

68. MECHANICAL SHOCK

69. The Model 8478B is a precision instrument. Avoid dropping or other mechanical shocks. Such shocks destroy the resistive match between thermistor elements, or otherwise degrade performance.

70. Test equipment and accessories required to perform maintenance are listed in Table 2. Equipment other than recommended models can be used provided the critical specifications are satisfied.

NOTE

The following procedures apply to the 8478B/432 combination. The same procedures can be used for the 431 except that the COARSE ZERO and FINE ZERO controls are replaced by the ZERO/VERNIER control.

66. 431 Power Meter Detector

67. Under normal operation, the total power supplied to heat thermistor pair "D" (see Figure 5) consists of: 1) RF signal, 2) 10 kHz bias, and 3) heat from the environment. The total power supplied to heat thermistor pair "C" consists of: 1) dc bias, 2) an equal amount of 10 kHz bias, and 3) heat from the same environment. As "D" and "C" are matched thermally, the total amounts of heat applied to reduce their series resistance equally must be equal.

Table 2. Recommended Test Equipment

Instrument Type	Critical Specifications	Recommended HP Model
Sweep Oscillator	Accuracy: $\pm 1\%$ full scale for all RF Units Leveling Capabilities Frequency Range: 8 GHz to 18 GHz	8690A, 8694A, 8695A
SWR Meter	Sensitivity: 0.15 μV for full scale deflection Accuracy: ± 0.05 dB/10 dB step Range: 70 dB in 10 dB steps	415E
Directional Detector	Frequency Range: 8.0 to 12.4 GHz Maximum SWR: 1.25:1	789C
Directional Coupler	Frequency Range: 12.4 to 18 GHz 10 dB Coupler SWR: $< 1.05:1$	P752C
Carriage	Accepts HP 816A Slotted Line	809C
Slotted Line	Frequency Range: 8 to 18 GHz Impedance: 50 ohms ± 0.2 ohms SWR: $< 1.06:1$, 8 to 18 GHz	816A
Probe	Frequency Range: 8 to 18 GHz	447B
Passband Filter	Passband Frequency: 12.4 to 18 GHz	P362A
Crystal Detector	Frequency Range: 12.4 to 18 GHz	P424A
Waveguide to Coax Adapter	Frequency Range: 12.4 to 18 GHz Connector - Type N	P281B
Power Meter	Power Range: 10 mW Accuracy: $\pm 1\%$ of full scale	432A
Digital Voltmeter	Input Impedance: 10 Megohm Resolution: 4 significant digits Accuracy: $\pm 0.05\%$	3466A
Power Supply	Output Voltage: 29 Vdc	6217A
Cables	1. Coax-Type N connectors 2. BNC-BNC - male connectors	11500A 10502A
Battery	Voltage +2.0 to 3.1 Vdc	See Paragraph 74
Resistor	2.2K ohm 5%	0698-4262

71. PERFORMANCE TESTS.

72. SWR Measurement, 8 GHz.

SPECIFICATION: SWR at 8 GHz = <1.35:1

DESCRIPTION: SWR measurement using standard SWR measurement techniques.

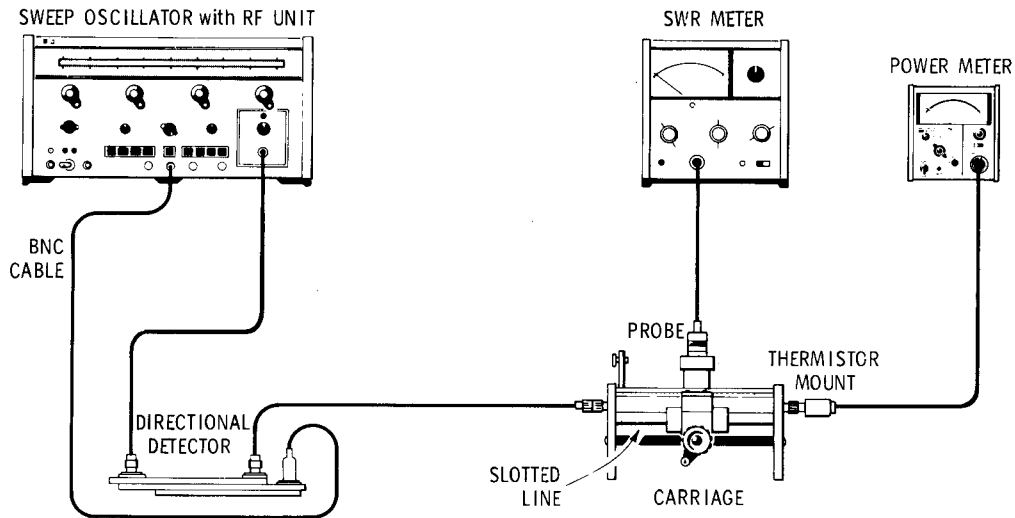

Figure 6. SWR Measurement Test, 8 GHz

PROCEDURE:

- a. Connect the test equipment as shown in Figure 6. Make sure all connections are secured tightly.
- b. Set the instrument controls as follows:

HP 8690B/8692A

SWEEP SELECTOR	CW
FUNCTION	START/STOP
ALC	IN
AMPLITUDE MOD	INT SQ WAVE
START/CW	8 GHz
POWER LEVEL	Adjust to maximum with the UNLEVELED light off

HP 415E

INPUT	XTAL IMPED - HIGH
RANGE-DB/EXPAND	30/NORM
GAIN/VERNIER	Centered

432

MOUNT RESISTANCE	200 ohms
RANGE	10 mW

PERFORMANCE TESTS (cont'd)

- c. Adjust the HP 8690B Sweep Oscillator INT SQ WAVE FREQ for a maximum reading on the HP 415E SWR meter.
- d. Adjust the HP 447B Probe penetration for a half scale reading on the SWR meter.
- e. Move the HP 809C Carriage adjustment for a maximum reading on the SWR meter.
- f. Use the 415E GAIN/VERNIER controls to set the SWR meter reading to 1.0 SWR on the 415E meter.
- g. Move the 415E RANGE-DB/EXPAND switch to 0. Adjust the GAIN/VERNIER controls for a 1.0 SWR reading.
- h. Move the 809C carriage adjustment for a minimum SWR reading on the 415E. The SWR at 8 GHz should be less than 1.35:1.
HP 415E (8 GHz) _____ <1.35:1
- i. Repeat steps a through h to determine the SWR at 12.4 GHz. The SWR at 12.4 GHz should be less than 1.35:1.
HP 415E (12.4 GHz) _____ <1.35:1.
-

PERFORMANCE TESTS (cont'd)

73. SWR Measurement, 15 and 18 GHz.

SPECIFICATION: SWR at 15 and 18 GHz = 1.6:1 maximum.

DESCRIPTION: SWR measurement using standard SWR measurement techniques.

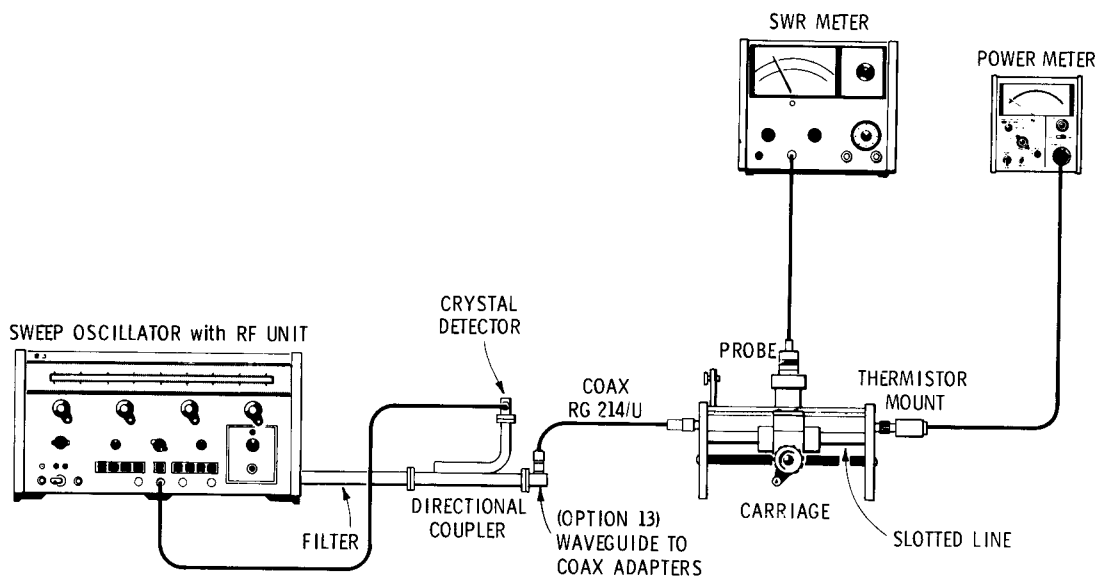

Figure 7. SWR Measurement, 15 and 18 GHz

PROCEDURE:

- a. Replace the RF unit, filter and directional detector in the 12 GHz test setup with the instruments shown in Figure 8.
- b. Repeat steps a through h to determine the SWR at 15 GHz. The SWR at 15 GHz should be 1.6:1 maximum.

HP 415E (15 GHz) _____ 1.6:1 maximum

- c. Move the 8690B START/CW control to 18 GHz. Repeat steps a through h to determine the SWR at 18 GHz. The SWR should be 1.6:1 maximum.

HP 415E (18 GHz) _____ 1.6:1 maximum.

PERFORMANCE TESTS (cont'd)

74. Thermistor Resistive Match Test.

SPECIFICATION: Thermistor match ± 0.5 ohm.

DESCRIPTION: The voltage drop across each thermistor is measured to check thermistor match.

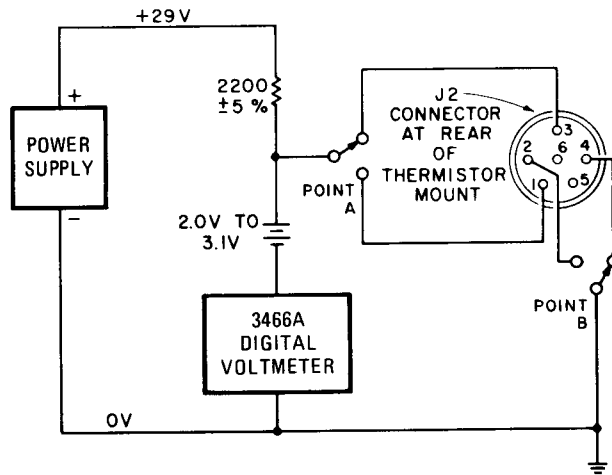

Figure 8. Thermistor Resistive Match Test

EQUIPMENT REQUIRED:

POWER SUPPLY	HP 6217A Power Supply
DIGITAL VOLTMETER	HP 3466A Digital Voltmeter
BATTERY	See Note
RESISTOR (2.2K $\pm 5\%$)	HP 0698-4262

NOTE

The small battery connected in series with the DVM is in opposition to the power supply. The value of this reverse voltage should be selected to provide voltmeter resolution of 0.001 volt.

PERFORMANCE TESTS (cont'd)

74. Thermistor Resistive Match Test (cont'd).

- a. Connect the equipment as shown in Figure 8. Set instrument controls as follows:

6217A

METER RANGE 30 VDC
 VOLTAGE ADJUST 29 VDC

3466A

RANGE AUTO

- b. Connect point A to pin 3 of the thermistor mount jack and point B to pin 4 of the thermistor mount jack.

- c. Record the DVM Reading.

3466A _____

- d. Connect point A to pin 1 of the thermistor mount jack and point B to pin 2 of the thermistor mount jack.

- e. Record the DVM Reading.

3466A _____

- f. Thermistor match ($\pm 0.5\Omega$) is satisfactory if the two readings do not differ by more than 0.03 volt.
 Difference _____ < 0.03 volt

75. TROUBLESHOOTING

76. Exceeding the CW or pulse power limits of the Model 8478B Thermistor Mount may result in damage such that the mount will no longer zero on the power meter.

77. Before adjusting the mount in any way, make sure that the mount is the cause of the problem. An

open or short indication, using the performance test or the check in Paragraph 80, means that the mount is not repairable by the procedure outlined in the following paragraphs. However, the mount may be nonoperative, but still repairable. Test for this by using the thermistor resistive match test procedure, or by connecting the mount

TROUBLESHOOTING (Cont'd)

to a power meter and cable which are known to be good. A faulty cable will not have continuity through the respective connector pins, or may have poor contact at the mount connector. Poor contact will show up as intermittence or a great deal of noise (visible on the power meter) when the cable is gently flexed near the connector end.

78. To troubleshoot a damaged mount, proceed as follows:

- a. Connect mount to Model 432.
- b. Set:
 MOUNT RES 200Ω
 RANGE COARSE ZERO
 POWER ON

c. Rotate COARSE ZERO from one limit to the other.

79. If meter remains pegged upscale, the thermistor elements have been damaged. However, it may be possible to recompensate the thermistors per Paragraphs 83 and 85 and return the mount to operation; otherwise they must be replaced. In either case, the Effective Efficiency and Calibration Factor data on the nameplate are no longer valid (refer to Paragraph 86).

80. If meter remains pegged downscale, measure resistance between pins 1 and 2, and pins 3 and 4. The resistance should measure between 1000 and 5000 ohms. An open or shorted reading indicates the need for replacement of the thermistors.

CAUTION

Under no conditions should the mount be required to carry a current higher than 14 mA.

81. THERMISTOR COMPENSATION

82. If the resistance reading is satisfactory, it may be possible to recompensate the mount, and return it to service. The drift with temperature changes will be higher because of the damage to the thermistors, but it will be possible to zero the meter and to make accurate measurements. The Effective Efficiency and Calibration Factor imprinted on the label will no longer be valid (refer to Paragraph 86). There are two adjusting screws which permit recompensation within limits.

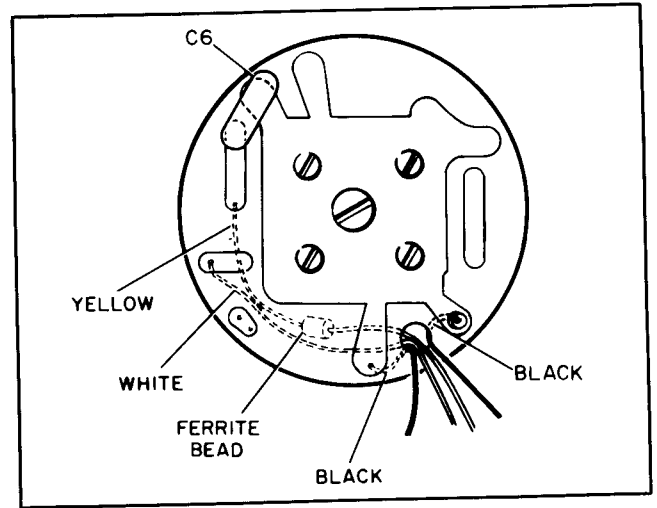

Figure 9. Printed Circuit Board

83. Refer to Figure 10 and proceed as follows:

- a. Remove the three screws (A).
- b. Slide terminal shield away from instrument.
- c. Plug connector J2 into Model 432A.
- d. Connect mount to 50Ω load.
- e. Set:
 MOUNT RES 200Ω
 POWER ON

84. If meter is pegged downscale:

- a. Set RANGE to COARSE ZERO.
- b. Set COARSE ZERO and adjustment to mid-range.
- c. Turn screws (B) clockwise, 1/8 turn alternately.

CAUTION

The compensating screws are in very close proximity to the thermistors themselves. Thermistor damage can easily occur if the screws are forced in any way.

If there is a sudden jump in meter indication when advancing either screw, back off 1/8 turn, and do not advance that screw further. Check resistance as in Paragraph 80. If either screw bottoms, do not apply force. Thermistor replacement is indicated.

- d. When meter pointer rises, trim to zero with each adjusting screw.

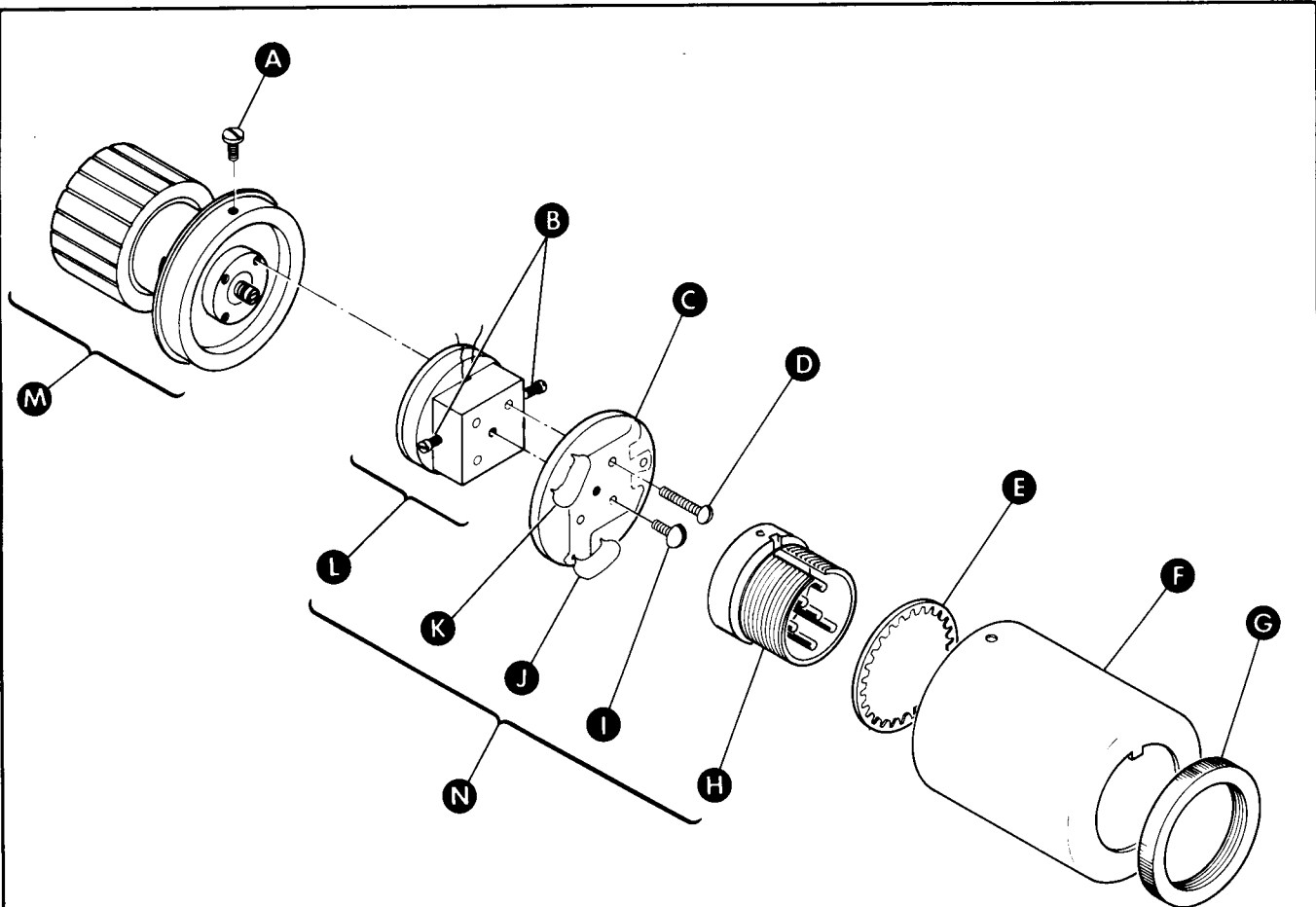

- A** Screw (3) 2-56 x 3/16 (0520-0123 for serial numbers prefixed 1833A, 2030A and 2106A; 0520-0173 for serial numbers prefixed below 1833A).
- B** Compensating adjustment screws 0-80 x 3/16 (0570-0122 for serial numbers prefixed 1833A, 2030A, and 2106A; 0516-0027 for serial numbers prefixed below 1833A).
- C** Printed circuit board 08478-2002.
- D** Screw (4) 2-56 x 3/4 0520-0137.
- E** Locking ring (1250-0016 for serial numbers prefixed 2030A and 2106A; 2190-0036 for serial numbers prefixed 1833A and below).
- F** Terminal shield (478A-18 for serial numbers prefixed 2030A and 2106A; 00478-00001 for serial numbers prefixed 1833A and below).
- G** Knurled nut 1251-1281.
- H** J2 receptacle connector 1251-0153. C4 not shown (used on mounts with serial numbers prefixed 1833A and below).
- I** Screw 4-40 x 3/4 2200-0101.
- J** C5 for serial numbers prefixed below 1833A only (selected in test).
- K** C6 340 pF (0140-0227). for serial numbers prefixed 2106A; not used for serial numbers prefixed 2030A; selected in test for serial numbers prefixed 1833A and below).
- L** Common thermal environment block.
- M** RF input connector assembly.
- N** Furnished in thermistor assembly replacement kit (08478-6012).

Figure 10. Thermistor Mount Assembly

e. Replace terminal shield and three screws (A). The instrument is now operative.

85. If meter is pegged upscale:

a. Set RANGE to highest position which will not peg the meter. If meter pegs on all ranges, set RANGE to 10 mW.

b. Turn one of the screws (B) counterclockwise to obtain a meter reading half that observed in step b.

c. Turn the other screw (B) counterclockwise to zero the meter. If it is impossible to zero the meter, replace the thermistors.

d. Set RANGE to COARSE ZERO; set COARSE ZERO adjustment to mid-range. If necessary, readjust compensation serials to zero the meter.

CAUTION

The compensating screws are in very close proximity to the thermistors themselves. Thermistor damage can easily occur if the screws are forced in any way.

If there is a sudden jump in meter indication when advancing either screw, back off 1/8 turn, and do not advance that screw further. Check resistance as in Paragraph 80. If either screw bottoms, do not apply force. Thermistor replacement is indicated.

e. Replace cover and three screws (A). The instrument is now operative.

NOTE

The three cover screws must be tight (use lock washers) for proper operation with 432A. If these screws are not tight noisy operation will occur.

86. REPAIR AND RECALIBRATION

87. If repair or recalibration of the mount is desired, the instrument may be returned to Hewlett-Packard for repair and recalibration, or for recalibration only. Arrangements can be made with any Hewlett-Packard Sales and Service office.

APPENDIX A MANUAL CHANGES

To adapt this manual to your instrument, refer to Table A1 and make all of the manual changes listed opposite your instrument serial number. Perform these changes in the sequence listed.

If your instrument serial number is not listed on page 2 of this manual or in Table A1 below, it may be documented in a yellow MANUAL CHANGES supplement.

Table A1. Manual Changes by Serial Number

Serial Number or Prefix	Make Manual Changes
Below 1833A	C, B, A
1833A	C, B,
2030A	C

CHANGE A

Page 3, Table 1:

Change Operating Resistance to "200 ohms. Balanced."

Page 5, paragraphs 26 and 27:

Replace these paragraphs with the following:

26. Unbalanced Operation with 431A/B or 430 Power Meters.

27. If the 8478B is used with a Model 431 Power Meter, a Model 11527A Adapter is required. If the 8478B is used with a 430 Power Meter, a Model 11528A Adapter is required. The use of an adapter breaks the balanced circuit and an unbalanced circuit results. In this unbalanced condition, a large amount of 10 kHz audio bias signal may be coupled from the power meter to the RF source output.

Page 5, paragraph 28:

Delete the first sentence (that is, "Because the mount . . . RF Source Output").

Page 5, paragraph 34 and 35:

Change the paragraph title to read: "8478B with Model 431A/B and 430 Power Meters".

Add the following to paragraph 35: "The Model 11527A or 11528A Adapter is required when operating the 8478B with 431A/B or 430 Power Meters respectively."

Page 8, Figures 4 and 5:

Replace Figures 4 and 5 with Figures A1 and A2 respectively.

CHANGE A (Cont'd)

Page 15, Figure 9:

Replace Figure 9 with Figure A3.

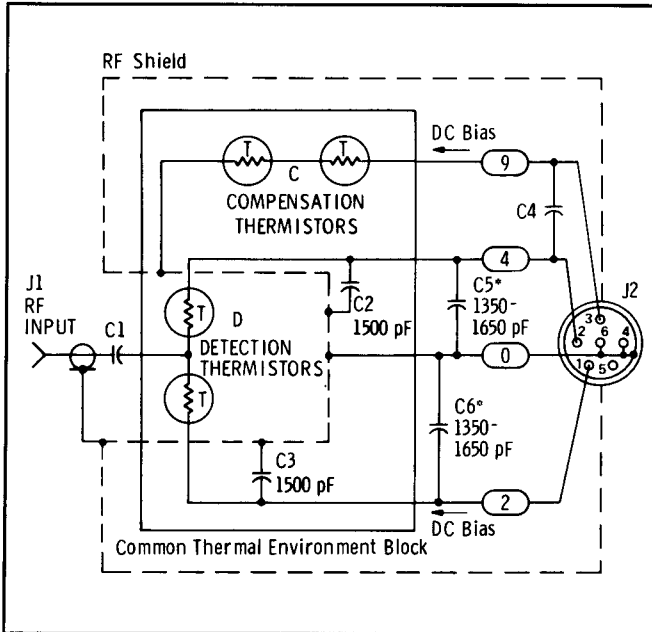

Figure A1. 8478B Connected to a 432A Power Meter (P/O Change A)

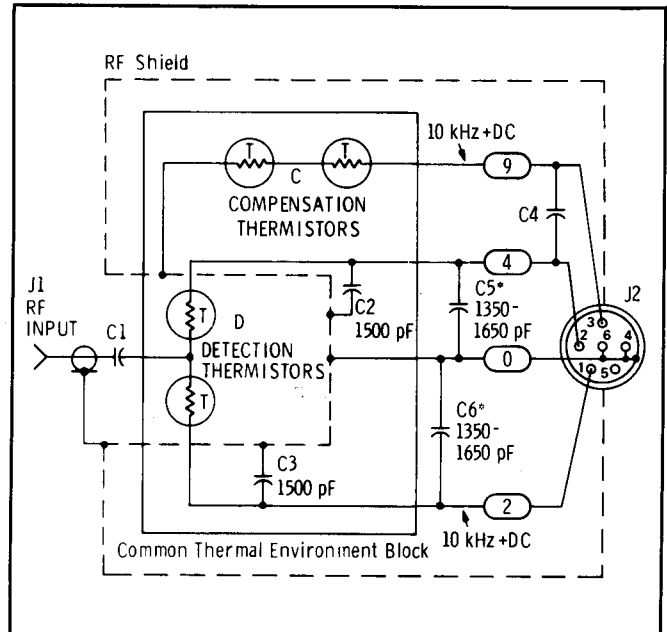

Figure A2. 8478B Connected to a 431C Power Meter (P/O Change A)

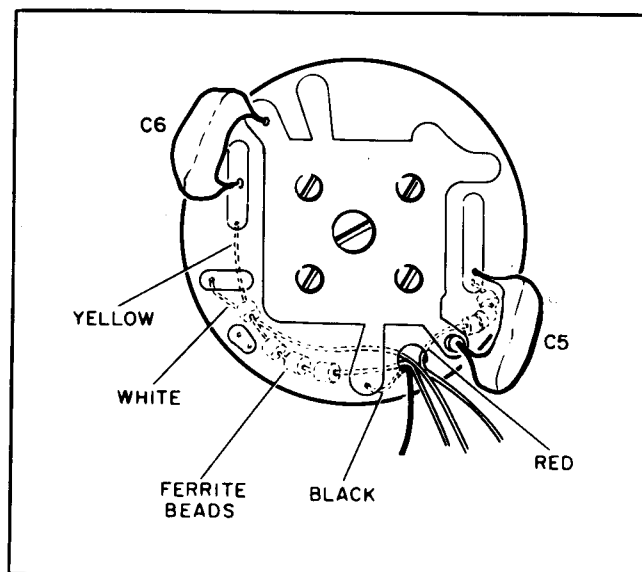

Figure A3. Printed Circuit Board (P/O CHANGE A)

CHANGE B

Page 8, Figures 4 and 5:

Replace Figures 4 and 5 with Figures A4 and A5 respectively.

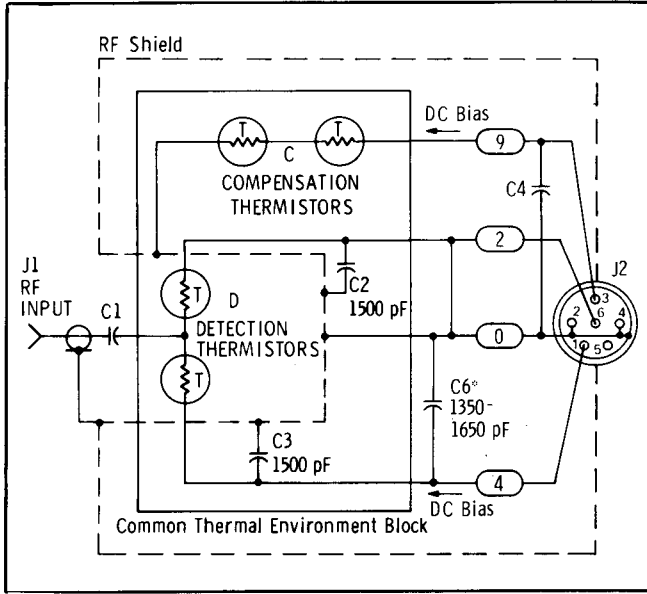

Figure A4. 8478B Connected to a 432A Power Meter (P/O Change B)

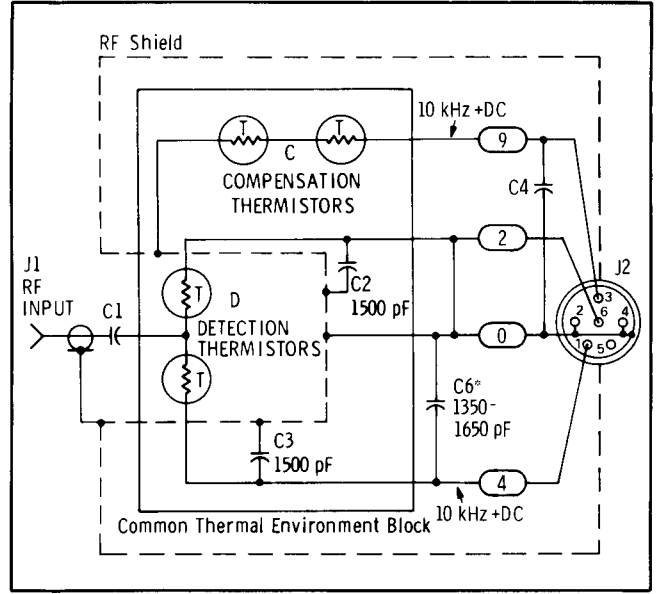

Figure A5. 8478B Connected to a 431C Power Meter (P/O Change B)

Page 15, Figure 9:

Return C6 as it is shown in the manual (it was deleted by Change C).

CHANGE C

Page 8, Figures 4 and 5:

Replace Figures 4 and 5 with Figures A6 and A7 respectively.

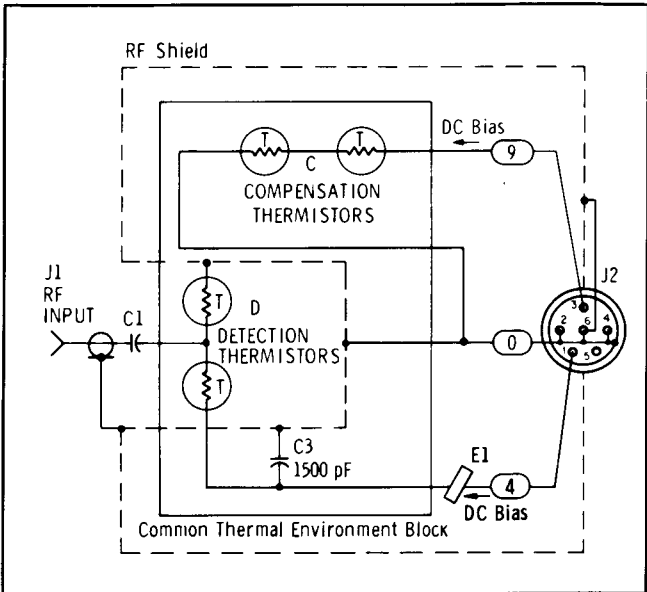

Figure A6. 8478B Connected to a 432A Power Meter (P/O Change C)

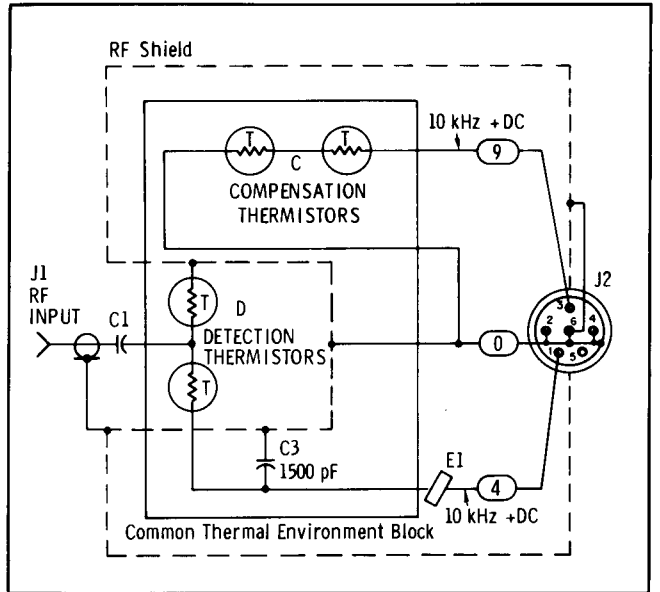

Figure A7. 8478B Connected to a 431C Power Meter (P/O Change C)

CHANGE C (Cont'd)

Page 15, Figure 9:

Replace Figure 9 with Figure A8.

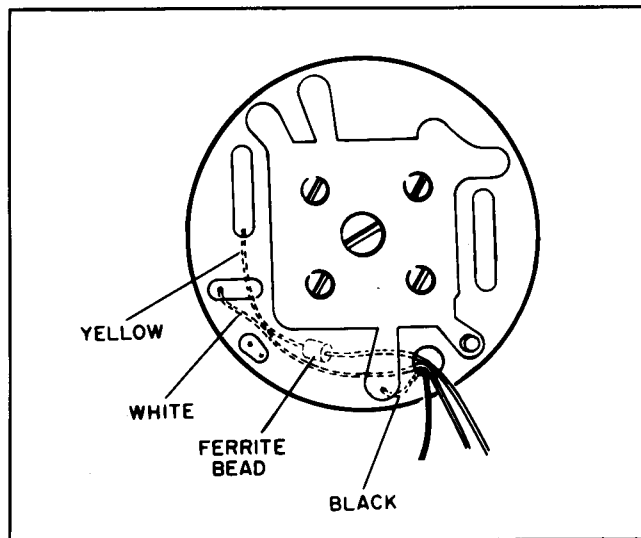

Figure A8. Printed Circuit Board (P/O Change C)

CERTIFICATION

Hewlett-Packard Company certifies that this product met its published specifications at the time of shipment from the factory. Hewlett-Packard further certifies that its calibration measurements are traceable to the United States National Bureau of Standards, to the extent allowed by the Bureau's calibration facility, and to the calibration facilities of other International Standards Organization members.

WARRANTY

This Hewlett-Packard instrument product is warranted against defects in material and workmanship for a period of one year from date of shipment. During the warranty period, Hewlett-Packard Company will, at its option, either repair or replace products which prove to be defective.

For warranty service or repair, this product must be returned to a service facility designated by HP. Buyer shall prepay shipping charges to HP and HP shall pay shipping charges to return the product to Buyer. However, Buyer shall pay all shipping charges, duties, and taxes for products returned to HP from another country.

HP warrants that its software and firmware designated by HP for use with an instrument will execute its programming instructions when properly installed on that instrument. HP does not warrant that the operation of the instrument, or software, or firmware will be uninterrupted or error free.

LIMITATION OF WARRANTY

The foregoing warranty shall not apply to defects resulting from improper or inadequate maintenance by Buyer, Buyer-supplied software or interfacing, unauthorized modification or misuse, operation outside of the environmental specifications for the product, or improper site preparation or maintenance.

NO OTHER WARRANTY IS EXPRESSED OR IMPLIED. HP SPECIFICALLY DISCLAIMS THE IMPLIED WARRANTIES OF MERCHANTABILITY AND FITNESS FOR A PARTICULAR PURPOSE.

EXCLUSIVE REMEDIES

THE REMEDIES PROVIDED HEREIN ARE BUYER'S SOLE AND EXCLUSIVE REMEDIES. HP SHALL NOT BE LIABLE FOR ANY DIRECT, INDIRECT, SPECIAL, INCIDENTAL, OR CONSEQUENTIAL DAMAGES, WHETHER BASED ON CONTRACT, TORT, OR ANY OTHER LEGAL THEORY.

ASSISTANCE

Product maintenance agreements and other customer assistance agreements are available for Hewlett-Packard products.

HEWLETT-PACKARD SERVICE OFFICES

To obtain servicing information, contact the nearest Hewlett-Packard Sales and Service Office in HP Catalog, or contact the nearest regional office listed below.

UNITED STATES

NO. CALIFORNIA (San Francisco Area)
333 Logue Ave.

Mt. View, CA 94043

SO. CALIFORNIA (Los Angeles Area)

5400 West Rosecrans Blvd.

Lawndale, CA 90260

GEORGIA

450 Interstate N. Parkway

Atlanta, GA 30348

ILLINOIS

5201 Tollview Dr.

Rolling Meadows, IL 60008

NEW JERSEY

W. 120 Century Rd.

Paramus, NJ 07652

AUSTRALIA

Hewlett-Packard Australia Ltd.

31-41 Joseph Street

Blackburn, Victoria 3130

CANADA

Hewlett-Packard (Canada) Ltd.

6877 Goreway Drive

Mississauga, Ontario

Canada L4V 1M8

ITALY

Hewlett-Packard Italiana S.p.A.

Via G. Di Vittorio, 9

20063 Cernusco

Sul Naviglio (MI)

FRANCE

Hewlett-Packard France

Quartier de Courtaboeuf

Boite Postale No. 6

F-91401 Orsay Cedex

GERMAN FEDERAL REPUBLIC

Hewlett-Packard GmbH

Vertriebszentrale Frankfurt

Bernerstrasse 117

Postfach 560 140

D-6000 Frankfurt 56

NETHERLANDS

Hewlett-Packard Benelux N.V.

Van Heuven Doedhartlaan 121

P.O. Box 667

NL-Amstelveen 1134

UNITED KINGDOM

Hewlett-Packard Ltd.

King Street Lane

GB-Winnersh, Wokingham

Berks, RG11 5AR

AFRICA, ASIA, CENTRAL AND SOUTH AMERICA

Hewlett-Packard Intercontinental

3200 Hillview Avenue

Palo Alto, CA 94304



HP MANUAL PART NO. 08478-90015
Microfiche Part No. 08478-90016

PRINTED IN U.S.A.