

| | |
|-------------------------------|---------------|
| COAXIAL ATTENUATOR | 8491A |
| | 8491B |
| | 8492A |
| | 8493A |
| | 8493B |
| ATTENUATOR SET | 11581A |
| | 11582A |
| | 11583A |

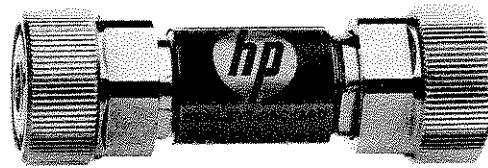

8492A

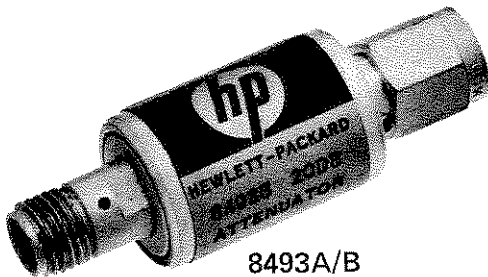

8493A/B



8491A/B



11581A, 11582A, 11583A*

*Attenuator Sets

Model 11581A consists of a 3, 6, 10, and 20 dB Model 8491A in a box.

Model 11582A consists of a 3, 6, 10, and 20 dB Model 8491B in a box.

Model 11583A consists of a 3, 6, 10, and 20 dB Model 8492A in a box.

Figure 1. 8490 Series Coaxial Attenuators

DESCRIPTION

8491A and B, 8492A, and 8493A and B attenuators are small, light-weight, low-power, 50-ohm fixed coaxial attenuators. Normal attenuation values are 3, 6, 10, 20, 30, 40, 50, and 60 dB. The attenuators cover broad frequency ranges with uniform attenuation and excellent phase linearity. Power handling capacity is two watts, average. Each attenuator is tested with an Automatic Network Analyzer for attenuation, and a plot of actual attenuation values is stamped on the metallic label attached to the body of the attenuator.

Model 8491 attenuators have Type N connectors, one male and one female. The A and B designations signify frequency range — A for dc to 12.4 GHz, and B for dc to 18 GHz. Model 8492A attenuators have precision 7-mm APC-7 connectors, and cover dc to 18 GHz. The Model 8493A/B attenuators have SMA 3-mm connectors and cover the same frequency ranges as the Model 8491A/B. Attenuators having the dc to 12.4 GHz frequency range are supplied with calibrations at dc, 4, 8, and 12 GHz. Attenuators covering dc to 18 GHz are supplied with calibrations at dc, 4, 8, 12, and 18 GHz.

Models 11581A, 11582A, and 11583A are boxed, four attenuator sets. Each set consists of a 3, 6, 10, and 20-db attenuator, and includes a calibration report on each attenuator. The reports give the actual attenuation and reflection coefficient of each port, normally at the same frequencies as those on the attenuator label. The reports also include the accuracy of the calibrations and certify traceability to National Bureau of Standards. The 11581A Attenuator Set contains 8491A attenuators, the 11582A set contains 8491B attenuators, and the 11583A set is comprised of 8492A attenuators. Figure 1 (page 2) shows the three models of attenuators and one boxed set. The other boxed sets are similar.

INITIAL INSPECTION

Mechanical Check

If damage to the shipping carton is evident, ask that the carrier's agent be present when the instrument is unpacked. Inspect the parts for mechanical damage, such as scratches or dents. Also, check the cushioning material for signs of severe stress.

Electrical Check

The electrical performance should be verified as soon as possible after receipt. Refer to Operator's Check or to Performance Test under MAINTENANCE.

Claim for Damage

If any unit is mechanically damaged or fails to meet specifications upon receipt, notify the carrier and your nearest Hewlett-Packard office immediately (a list of offices is at the end of this manual). Retain the shipping carton and the padding material for the carrier's inspection. The HP office will arrange for repair or replacement without waiting for the claim against the carrier to be settled.

REPACKAGING FOR SHIPMENT

Using Original Packaging

The same containers and materials used in factory packaging can be obtained through the HP offices listed at the end of this manual.

Using Other Packaging

If it is desired to return an attenuator without a case, the following general instructions should be used for repackaging with commercially-available materials.

- a. Wrap attenuator in heavy paper or pastic; (if shipping to a Hewlett-Packard office attach a tag indicating the type of service required, return address, and model number).
- b. Use a strong shipping container.
- c. Use enough shock-absorbing material (3 to 4 inch layer) around the attenuator to provide a firm cushion and prevent movement inside the container.
- d. Seal the shipping carton securely.
- e. Mark the shipping carton **FRAGILE** to assure careful handling.

Policy on Returning Attenuator for Warranty

"Bad Contacts" attenuators are returnable under warranty while "Burned Out" attenuators are not. These terms are defined as follows:

"Bad Contacts": Attenuation is within specifications at 8 GHz or higher; attenuation is at least 3 to 5 dB higher than specification at dc and 1 kHz.

"Burned Out": Attenuation is at least 3 to 5 dB higher than specification at dc and entire rated frequency range.

This policy applies to all attenuators under warranty and does not affect the fact that the model 8492A is the only repairable attenuator.

Table 1. Specifications

| Frequency Range | 8491A and 8493A 4 | | 8491B and 8493B 4 | | | 8492A | | |
|-------------------------|--|------------|--|-------------|-------------|-------------------------------|-------------|-------------|
| | DC to 12.4 GHz | | DC to 18 GHz | | | DC to 18 GHz | | |
| | | | DC-12.4 GHz | 12.4-18 GHz | | DC-12.4 GHz | 12.4-18 GHz | |
| Attenuation Accuracy 5 | | | ±0.3 dB | | | ±0.3 dB | | |
| 3 dB | ±0.3 dB | | ±0.3 dB | | | ±0.3 dB | | |
| 6 dB | ±0.3 dB | | ±0.4 dB | | | ±0.4 dB | | |
| 10 dB | ±0.5 dB | | ±0.5 dB | | | ±0.5 dB | | |
| 20 dB | ±0.5 dB | | ±0.5 dB | | ±1 dB | ±0.5 dB | | ±1 dB |
| 30 dB | ±1 dB | | ±1 dB | | | ±1 dB | | |
| 40 dB 4 | ±1.5 dB | | ±1.5 dB | | | ±1.5 dB | | |
| 50 dB 4 | ±1.5 dB | | ±1.5 dB | | | ±1.5 dB | | |
| 60 dB 4 | ±2 dB | | ±2 dB | | | ±2 dB | | |
| SWR | DC-8 GHz | 8-12.4 GHz | DC-8 GHz | 8-12.4 GHz | 12.4-18 GHz | DC-8 GHz | 8-12.4 GHz | 12.4-18 GHz |
| 3 dB | 1.25 | 1.35 | 1.25 | 1.35 | 1.5 | 1.2 | 1.3 | 1.5 |
| 6 dB | 1.2 | 1.3 | 1.2 | 1.3 | 1.5 | 1.2 | 1.3 | 1.35 |
| 10 dB | 1.2 | 1.3 | 1.2 | 1.3 | 1.5 | 1.15 | 1.25 | 1.3 |
| 20 dB | 1.2 | 1.3 | 1.2 | 1.3 | 1.5 | 1.15 | 1.25 | 1.3 |
| 30 dB | 1.2 | 1.3 | 1.2 | 1.3 | 1.5 | 1.15 | 1.25 | 1.35 |
| 40 dB 4 | 1.2 | 1.3 | 1.2 | 1.3 | 1.5 | 1.15 | 1.25 | 1.35 |
| 50 dB 4 | 1.2 | 1.3 | 1.2 | 1.3 | 1.5 | 1.15 | 1.25 | 1.35 |
| 60 dB 4 | 1.2 | 1.3 | 1.2 | 1.3 | 1.5 | 1.15 | 1.25 | 1.35 |
| Calibration Frequencies | DC, 4, 8, 12 GHz | | DC, 4, 8, 12, 18 GHz | | | DC, 4, 8, 12, 18 GHz | | |
| Maximum Input Power | 2 W avg, 100 W pk | | 2 W avg, 100 W pk | | | 2 W avg, 100 W pk | | |
| Connectors (50 Ω) | 8491A: Type N ¹ 8493A: SMA ² | | 8491B: Type N ¹ 8493B: SMA ² | | | APC-7 ³ | | |
| Dimensions: In. mm | 8491A: 2-7/16 x 13/16 dia. 67 x 21 8493A: 1-9/16 x 1/2 dia. 40 x 13 | | 8491B: 2-7/16 x 13/16 dia. 67 x 21 8493B: 1-9/16 x 1/2 dia. 40 x 13 | | | 2 3/4 x 13/16 dia. 70 x 21 | | |
| Weight: net | 8491A: 110 g (4 oz) 8493A: 30 g (1 oz) | | 8491B: 110 g (4 oz) 8493B: 30 g (1 oz) | | | 110 g (4 oz) | | |

¹ Mate with MIL-C-71 and MIL-C-39012 connectors.

² Miniature SMA type.

³ Amphenol RF Division, Danbury, Connecticut.

⁴ 40, 50, 60-dB Attenuation not available in Models 8493A and 8493B.

⁵ Option numbers same as attenuation values; e.g. Option 003 for 3 dB, Option 006 for 6 dB, Option 010 for 10 dB, etc.

Option 890 Calibration Data provides a hard copy of the transmission and reflection data as tested on a Hewlett-Packard Automatic Network Analyzer, Model 8542B.

ATTENUATOR SET:

- 11581A (FOR 8491A) INCLUDES 3, 6, 10, 20 dB VALUES,
- 11582A (FOR 8491B) INCLUDES 3, 6, 10, 20 dB VALUES,
- 11583A (FOR 8492A) INCLUDES 3, 6, 10, 20 dB VALUES,

ACCURACY OF INSERTION LOSS MEASUREMENTS (S₂₁, S₁₂)

| Attenuation | DC | 4-12 GHz | 12-18 GHz |
|-------------|----------|----------|-----------|
| 3 dB | ±0.01 dB | ±0.06 dB | ±0.11 dB |
| 6 dB | ±0.01 dB | ±0.07 dB | ±0.11 dB |
| 10 dB | ±0.01 dB | ±0.07 dB | ±0.12 dB |
| 20 dB | ±0.01 dB | ±0.08 dB | ±0.13 dB |

ACCURACY OF REFLECTION COEFFICIENT MEASUREMENTS (S₁₁, S₂₂)

| Model Number | LEFT | | RIGHT | |
|--------------|----------|-----------|----------|-----------|
| | 4-12 GHz | 12-18 GHz | 4-12 GHz | 12-18 GHz |
| 11581A | ±.006 | — | ±.006 | — |
| 11582A | ±.006 | ±.010 | ±.006 | ±.006 |
| 11583A | ±.006 | ±.006 | ±.006 | ±.006 |

OPERATOR'S CHECK

DESCRIPTION:

The attenuator is driven from a 50-ohm signal source at 1 kHz. The output level from the attenuator is detected by a narrow-bandwidth voltmeter. The attenuator and detector range switches are stepped together and the variations in level noted. This verifies that each attenuator section is being properly switched and checks the low-frequency accuracy of the attenuator.

NOTE

The SWR meter used in this check is calibrated for a square-law detector and therefore the range changes and errors (read in dB) are twice that indicated by the meter.

PROCEDURE:

1. Connect equipment as shown above except remove the attenuator and connect the adapters directly together.
2. Set test oscillator to 0.3 Vrms at 1 kHz.
3. Set SWR meter range to 2 dB (expanded) [or for the 3 dB, 6 dB, and 10 dB attenuators to 10 dB (expanded)] and adjust its bandwidth to center of adjustment range. Fine tune oscillator frequency to obtain maximum meter indication. Adjust the Oscillator Output to obtain the SWR meter reading in the table below.
4. Connect the attenuator into the system, adjust the SWR meter range switch as listed below, and verify that SWR meter indicates within limits shown.

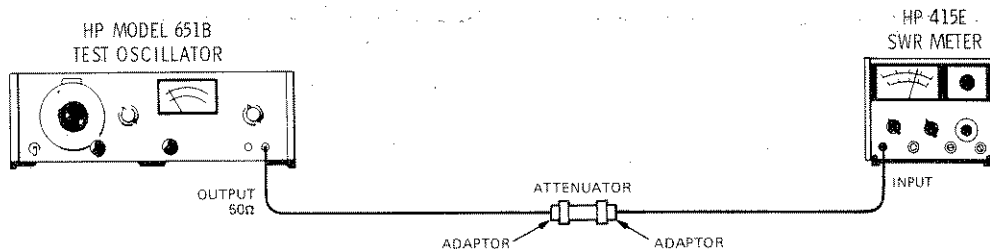

| Attenuation (dB) | SWR Meter Range (dB) | Meter Indication (dB) | | |
|------------------|----------------------|-----------------------|----------------------|---------|
| | | Minimum | Actual | Maximum |
| 0 (System Cal) | 2 (or 10)* | | Set to 0.5 (or 0.0)* | |
| 3 | 10 | 1.35 | _____ | 1.65 |
| 6 | 12 | 0.85 | _____ | 1.15 |
| 10 | 14 | 0.75 | _____ | 1.25 |
| 20 | 12 | 0.25 | _____ | 0.75 |
| 30 | 16 | 1.00 | _____ | 2.00 |
| 40 | 22 | -0.25 | _____ | 1.25 |
| 50 | 26 | 0.75 | _____ | 2.25 |
| 60 | 32 | -0.50 | _____ | 1.50 |

*Set SWR Meter range to 10 dB and power level to 0.0 dB for 3 dB, 6 dB, and 10 dB Attenuators only.

Figure 2. Operator's Check

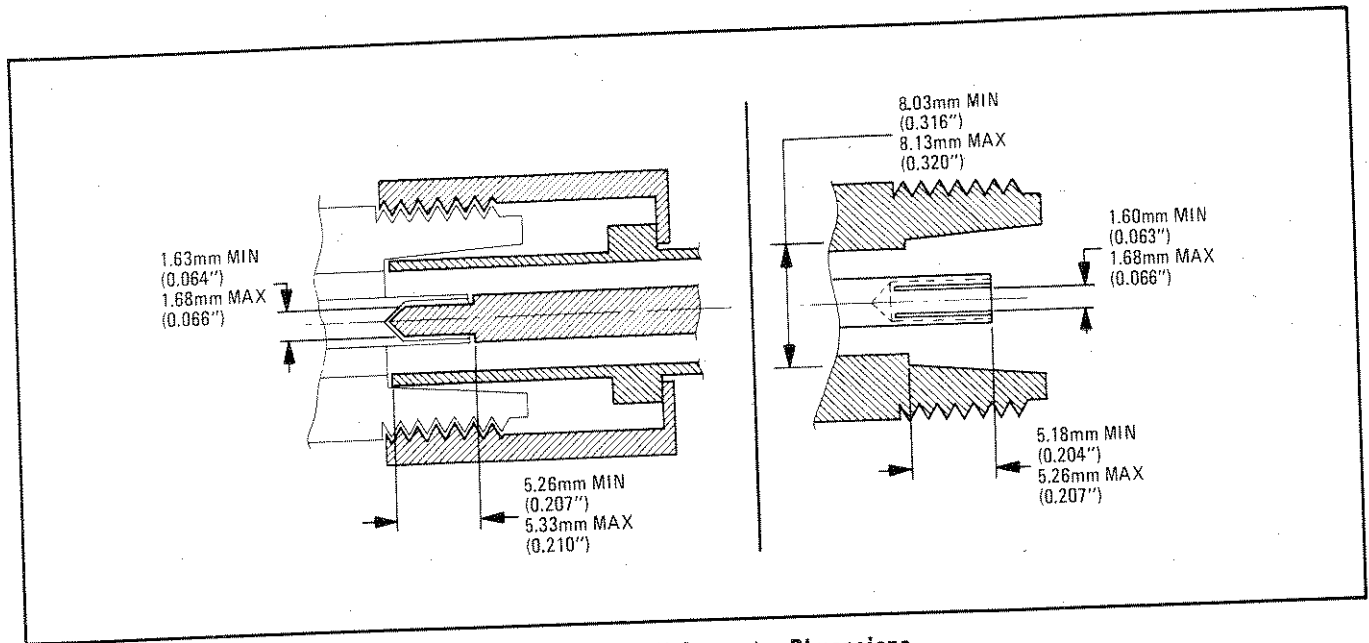

Figure 3. Type N Connector Dimensions

OPERATION

The Model 8491A/B Type N connectors mate with all Type N connectors whose dimensions conform to MIL-C-71B and MIL-C-39012. DO NOT mate with HP 0.071" pin *male* connector. Damage will result. See Figure 3 for connector dimensions.

The Model 8492A has APC-7* connectors which mate with other APC-7 connectors. These connectors are sexless and any APC-7 connector will mate with any other APC-7 connector. Load limits for these connectors are given in Figure 5. These load limits are given by the connector manufacturer and must not be exceeded in any case. See Figures 6 and 7 for instructions and recommendations concerning the use of APC-7 connectors.

The Model 8493A/B has a male SMA jack on one end and a female SMA on the other. These connectors mate with the opposite sex SMA connectors. (See Figure 4 for dimensions.) These connectors will support the weight of the Model 8493A/B but they should not be subjected to additional weight or torque.

With any of these attenuators do not depend upon the attenuator itself to bear any force. The units the attenuator is connected to should bear their own weight and force. Figure 5 gives the load limits permitted with 8492A attenuators. The attenuators are bidirectional, i.e., the signal may be inserted from either end.

These attenuators are not only flat in frequency but in addition, their phase response is quite linear. Linear phase response makes the attenuators suitable for precision pulse work which requires not only constant attenuation over a wide bandwidth, but also constant group delay.

OPERATOR'S CHECK

The operator's check is supplied to allow the operator to make a quick check of the instrument prior to use or if a failure is suspected.

THEORY

Precision silkscreening and semi-automated thin-film deposition are employed in the manufacture of the coaxial attenuators. Silver input, output, and ground electrodes are silkscreened onto the dielectric substrates. Then the cards are loaded into special fixtures and aligned under a microscope to make certain that the resistive film will be deposited in the right places.

Next, the fixtures containing the cards are placed in a vacuum chamber and a thin film of resistive material is evaporated onto them. The process is precisely controlled. Each card is tested repeatedly as the film is being deposited. The finished cards do not require any hand touch-up.

Before the cards are removed from the vacuum chamber, a microscopic coating of silicon monoxide is evaporated onto them to increase their

*Amphenol RF Division, Danbury, Conn. 06810

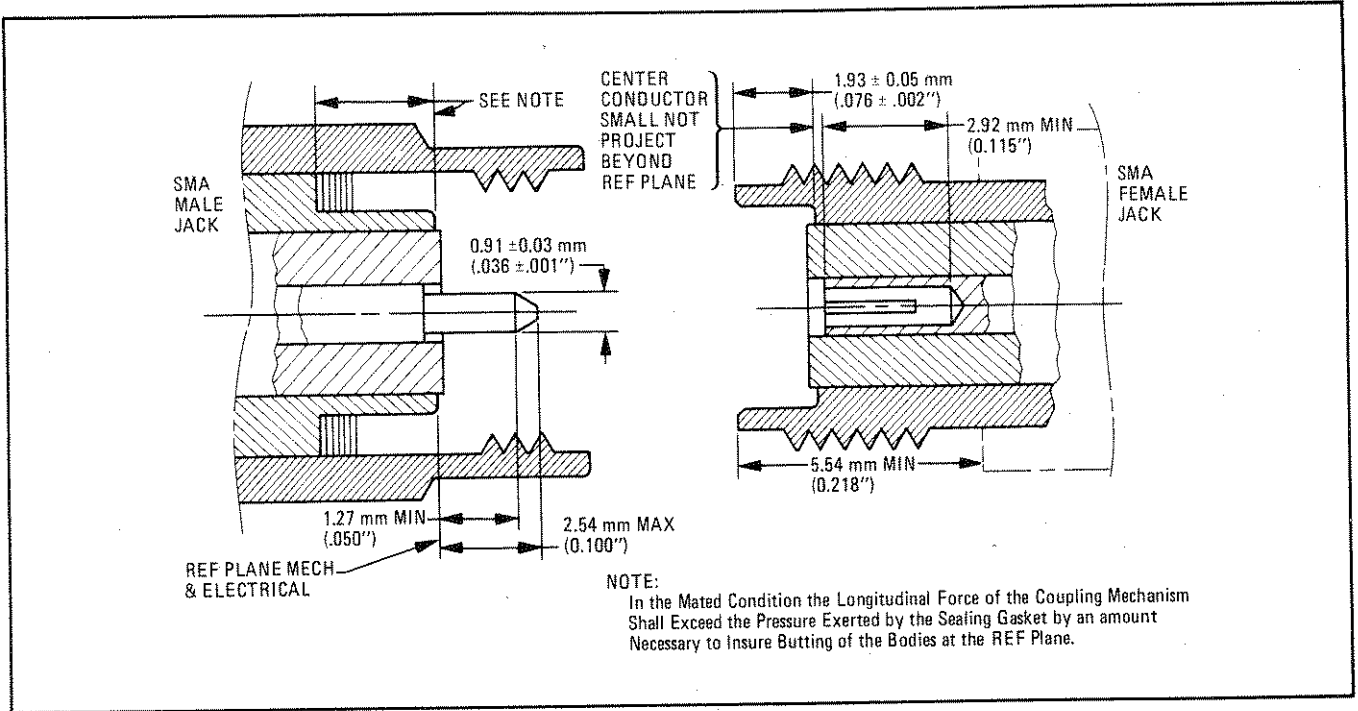

Figure 4. SMA Connector Dimension

THEORY (Cont'd)

stability and protect them from hostile environments. The cards are then removed, tested, and loaded into their cartridges. The cartridges protect the cards. Do not remove the cards from their cartridges as they can be damaged easily.

MAINTENANCE

The connectors, and particularly the connector faces, must be kept clean. This is particularly true of the 8492A and 8493A/B. See Figure 7 for APC-7 cleaning instructions.

Performance Test

The attenuators can be tested to the accuracy of the specifications in Table 1 with an automatic Network Analyzer or equivalent equipment of suitable accuracy. If an Automatic Network Analyzer is available, test the instrument using the procedure in the analyzer's operating manual.

Parts Replacement

Model 8491A/B. The Model 8491A/B is not recommended for repair since the cards must be mounted in cartridges to test and testing costs more than a replacement attenuator.

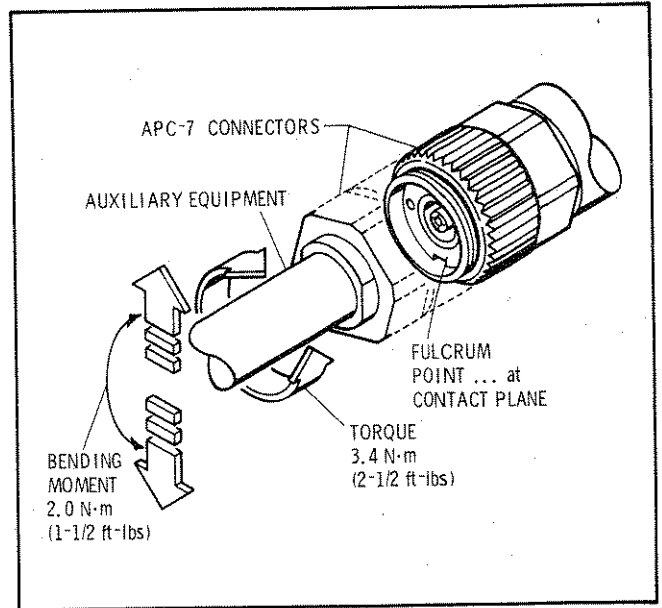

Figure 5. APC-7 Connector Load Limits

Model 8492A. The only part recommended for customer repair is the inner conductor contact. Refer to Figure 8 for instructions. If anything else needs to be replaced return the attenuator to the factory (see REPACKING FOR SHIPMENT and POLICY ON RETURNING ATTENUATOR FOR WARRANTY).

| | |
|--|---|
| <p>To Connect:</p> <ol style="list-style-type: none"> 1. On one connector, retract the coupling sleeve by turning the coupling nut counterclockwise until the sleeve and nut disengage. 2. On the other connector, fully extend the coupling sleeve by turning the coupling nut clockwise. To engage coupling sleeve and coupling nut when the sleeve is fully retracted, press back lightly on the nut while turning it clockwise. 3. Push the connectors firmly together, and thread the coupling nut of the connector with retracted sleeve over the extended sleeve. 4. Do NOT tighten the other coupling nut since this will tend to loosen the electrical connection. | <p>To Disconnect:</p> <ol style="list-style-type: none"> 1. Loosen the coupling nut of the connector showing the wider gold band. <div style="text-align: center; margin: 10px 0;">  <p style="margin: 0;">WIDER BAND</p> </div> <ol style="list-style-type: none"> 2. IMPORTANT: Part the connectors carefully to prevent striking the inner conductor contact. |
|--|---|

Figure 6. Use of APC-7 Connectors

Parts Replacement (Cont'd)

NOTE

If inner conductor contact is replaced, unit cannot be assured to retain original calibration values.

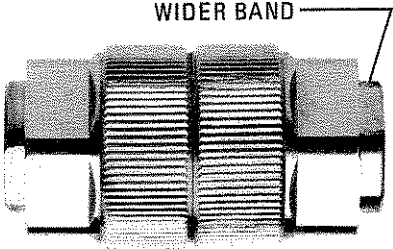
Model 8493A/B. The Model 8493A/B is not recommended for repair for the same reasons given for the Model 8491A/B.

Replaceable Parts

Table 2 lists the replaceable parts which are the only parts that can be replaced without access to the interior of the instrument.

To order a part listed in the Replaceable Parts table, quote the Hewlett-Packard Part Number,

indicate the quantity required, and address the order to the nearest Hewlett-Packard office.

Table 2. Replaceable Parts

| Description | Part Number | CD |
|------------------------------------|----------------|----|
| Tray (11581A, 11582A) | HP 11581-40001 | 1 |
| Tray (11583A) | HP 9220-1292 | 9 |
| Foam Pad (top, all sets) | HP 9220-1291 | 0 |
| Foam Pad (bottom, all sets) | HP 9220-1297 | 6 |
| Box, Walnut (all sets) | HP 9211-1009 | 9 |
| Inner Conductor Contact (8492A) | HP 1250-0907 | 8 |

1. Keep contacting surfaces smooth and clean. Irregularities and foreign particles can degrade performance.
2. Protect the contacting surfaces when connector is not in use by leaving the coupling sleeve extended.
3. Use lintless material and/or firm-bristled brush such as tooth brush for cleaning. If a cleaning fluid is needed use isopropyl alcohol. **IMPORTANT:** Do not use aromatic or chlorinated hydrocarbons, esters, ethers, terpenes, higher alcohols, ketones, or ether-alcohols such as benzene, toluene, turpentine, dioxane, gasoline, cellosolve acetate, or carbon tetrachloride. Keep exposure of the connector parts to both the cleaning fluid and its vapors as brief as possible.

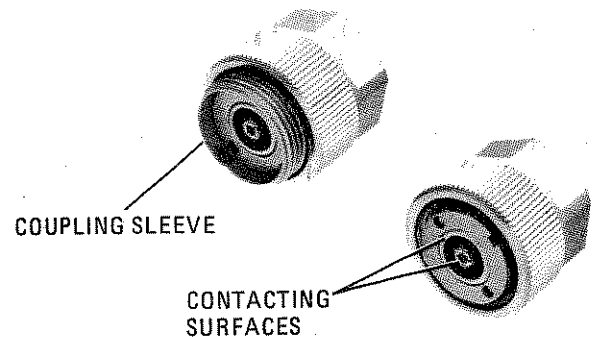
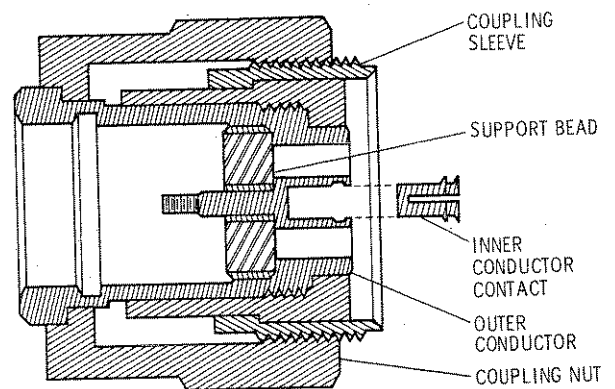

Figure 7. Care of APC-7 Connectors

Through wear or damage, the contact in the center conductor may need replacing. This contact is a small four-pronged collet which snaps into a recess in the center conductor. This contact is normally held in by the spring-action of the four prongs. With a magnifying glass examine this contact to determine if it needs replacement. **DO NOT REMOVE THIS CONTACT FOR INSPECTION** (it may be damaged by removing). The contact should be free of burrs or wear and the prongs should be equally spaced. If the contact is removed do **NOT** re-use it (it may be damaged by removal). This contact is Amphenol* part number 131-129 and HP 1250-0907. If this contact needs replacement proceed as follows:

- a. Place the instrument so the connector faces down.
- b. Tap the connector lightly and the contact should now protrude slightly. Insert the centering pin of the

*Amphenol RF Division, Danbury, Conn. 06810



HP contact extractor, part number 5060-0236, with the jaws open.

- c. Allow the jaws on the tool used to close and pull straight away from the connector without twisting.
- d. Snap in a new contact by pushing a new contact in place.

Figure 8. Replacing APC-7 Center Contact

CERTIFICATION

The Hewlett-Packard Company certifies that this instrument met its published specifications at the time of shipment from the factory. Hewlett-Packard Company further certifies that its calibration measurements are traceable to the United States National Bureau of Standards, to the extent allowed by the Bureau's calibration facility, and to the calibration facilities of other International Standards Organization members.

WARRANTY AND ASSISTANCE

This Hewlett-Packard product is warranted against defects in materials and workmanship for a period of one year from the date of shipment. Hewlett-Packard will, at its option, repair or replace products which prove to be defective during the warranty period provided they are returned to Hewlett-Packard. Repairs necessitated by misuse of the product are not covered by this warranty. **NO OTHER WARRANTIES ARE EXPRESSED OR IMPLIED, INCLUDING, BUT NOT LIMITED TO, THE IMPLIED WARRANTIES OF MERCHANTABILITY AND FITNESS FOR A PARTICULAR PURPOSE. HEWLETT-PACKARD IS NOT LIABLE FOR CONSEQUENTIAL DAMAGES.**

Service contracts or customer assistance agreements are available for Hewlett-Packard products.

HEWLETT-PACKARD SERVICE OFFICES

To obtain servicing information, contact the nearest Hewlett-Packard Sales and Service Office in HP Catalog, or contact the nearest regional office listed below.

• UNITED STATES

NO. CALIFORNIA (San Francisco Area)
333 Logue Ave.
Mt. View, CA 94043

SO. CALIFORNIA (Los Angeles Area)
5400 West Rosecrans Blvd.
Lawndale, CA 90260

GEORGIA

450 Interstate N. Parkway
Atlanta, GA 30348

ILLINOIS

5201 Tollview Dr.
Rolling Meadows, IL 60008

NEW JERSEY

W. 120 Century Rd.
Paramus, NJ 07652

• AUSTRALIA

Hewlett-Packard Australia Ltd.
31-41 Joseph Street
Blackburn, Victoria 3130

• CANADA

Hewlett-Packard (Canada) Ltd.
6877 Goreway Drive
Mississauga, Ontario
Canada L4V 1M8

• ITALY

Hewlett-Packard Italiana S.P.A.
Casella Postale 3645
I-20100 Milano

• FRANCE

Hewlett-Packard France
Quartier de Courtaboeuf
Boite Postale No. 6
F-91401 Orsay Cedex

• GERMAN FEDERAL REPUBLIC

Hewlett-Packard GmbH
Vertriebszentrale Frankfurt
Bernerstrasse 117
Postfach 560 140
D-6000 Frankfurt 56

• NETHERLANDS

Hewlett-Packard Benelux N.V.
Van Heuven Doedhartlaan 121
P.O. Box 667
NL-Amstelveen 1134

• UNITED KINGDOM

Hewlett-Packard Ltd.
King Street Lane
GB-Winnersh, Wokingham
Bers. RG11 5AR

• AFRICA, ASIA, CENTRAL AND SOUTH AMERICA

Hewlett-Packard Intercontinental
3200 Hillview Avenue
Palo Alto, CA 94304