

**HP 85046A
HP 85046B
S-PARAMETER TEST SET**

SERIAL NUMBERS

This manual applies directly to any HP 85046A or 85046B S-parameter test set with serial number prefix 3033A and above.

For additional information about serial numbers, refer to INSTRUMENTS COVERED BY MANUAL in Section I.

© Copyright HEWLETT-PACKARD COMPANY 1986
1400 FOUNTAINGROVE PARKWAY, SANTA ROSA, CA 95403 U.S.A.

MANUAL PART NO. 85046-90001
Microfiche Part Number 85046-90002

Printed: AUGUST 1990
Edition 3



**HEWLETT
PACKARD**

CERTIFICATION

Hewlett-Packard Company certifies that this product met its published specifications at the time of shipment from the factory. Hewlett-Packard further certifies that its calibration measurements are traceable to the United States National Bureau of Standards, to the extent allowed by the Bureau's calibration facility, and to the calibration facilities of other International Standards Organization members.

WARRANTY

This Hewlett-Packard instrument product is warranted against defects in material and workmanship for a period of one year from date of delivery. During the warranty period, Hewlett-Packard Company will, at its option, either repair or replace products which prove to be defective.

For warranty service or repair, this product must be returned to a service facility designated by HP. Buyer shall prepay shipping charges to HP and HP shall pay shipping charges to return the product to Buyer. However, Buyer shall pay all shipping charges, duties, and taxes for products returned to HP from another country.

HP warrants that its software and firmware designated by HP for use with an instrument will execute its programming instructions when properly installed on that instrument. HP does not warrant that the operation of the instrument, or software, or firmware will be uninterrupted or error free.

LIMITATION OF WARRANTY

The foregoing warranty shall not apply to defects resulting from improper or inadequate maintenance by Buyer, Buyer-supplied software or interfacing, unauthorized modification or misuse, operation outside of the environmental specifications for the product, or improper site preparation or maintenance.

NO OTHER WARRANTY IS EXPRESSED OR IMPLIED. HP SPECIFICALLY DISCLAIMS THE IMPLIED WARRANTIES OF MERCHANTABILITY AND FITNESS FOR A PARTICULAR PURPOSE.

EXCLUSIVE REMEDIES

THE REMEDIES PROVIDED HEREIN ARE BUYER'S SOLE AND EXCLUSIVE REMEDIES. HP SHALL NOT BE LIABLE FOR ANY DIRECT, INDIRECT, SPECIAL, INCIDENTAL, OR CONSEQUENTIAL DAMAGES, WHETHER BASED ON CONTRACT, TORT, OR ANY OTHER LEGAL THEORY.

ASSISTANCE

Product maintenance agreements and other customer assistance agreements are available for Hewlett-Packard products.

For any assistance, contact your nearest Hewlett-Packard Sales and Service Office. Addresses are provided at the back of this manual.

TABLE OF CONTENTS

Section 1 General Information

Introduction	1
Using the HP 85046	1
Instruments Covered by Manual	1
Description and Operating Characteristics of the Instrument	2
Options	2
Accessories	3
Accessories Supplied	3
Accessories Available	3
Calibration and Accessory Kits	3
Cable Sets	3
Transistor Fixtures	3
Operating and Safety Precautions	4
Service	4
Additional Equipment Required	4
Specifications	5

Section 2 Installation

Introduction	1
Initial Inspection	1
Environmental Considerations	1
Operation and Storage	1
Preparation for Use	2
Positioning the Test Set	2
Connecting the Test Set	2
Mating Connectors	2
Power and Control Connections	2
Signal Path Connections	2
Bias Connections	2
Packaging	3

Section 3 Operation

Introduction	1
Operator's Check	3
Equipment	3
Procedure	3
Solid-State Switch Operation Considerations	4

Section 4 Performance Tests

Introduction	1
DIRECTIVITY	2
PORT MATCH	4
SWITCH REPEATABILITY	7
EFFECTIVE SOURCE MATCH	9
Performance Test Record	11

Section 5 Adjustments

Section 6 Replaceable Parts

Introduction	1
Exchange Assemblies Available	1
Replaceable Parts Lists	1

Section 7 Manual Backdating Changes

Introduction	1
Application	1

Section 8 Service

Introduction	1
Troubleshooting	1
Servicing the Directional Bridge	1
Overall Troubleshooting Procedure	1
RF Troubleshooting Procedure	2
Logic Control Assembly Troubleshooting	2

INDEX

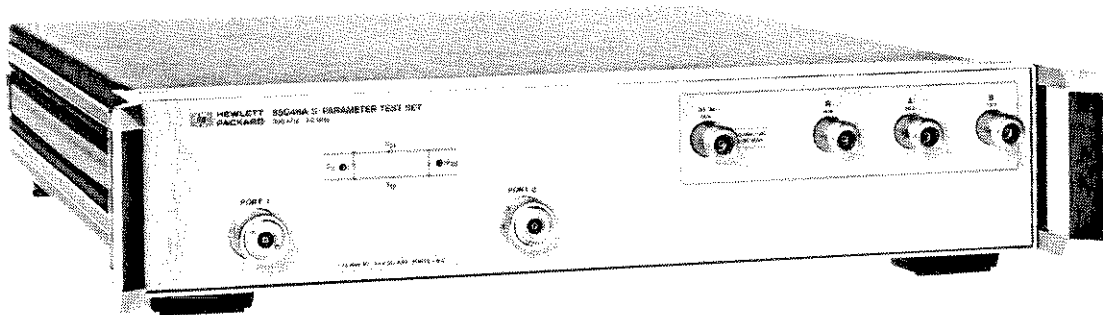

HP 85046A

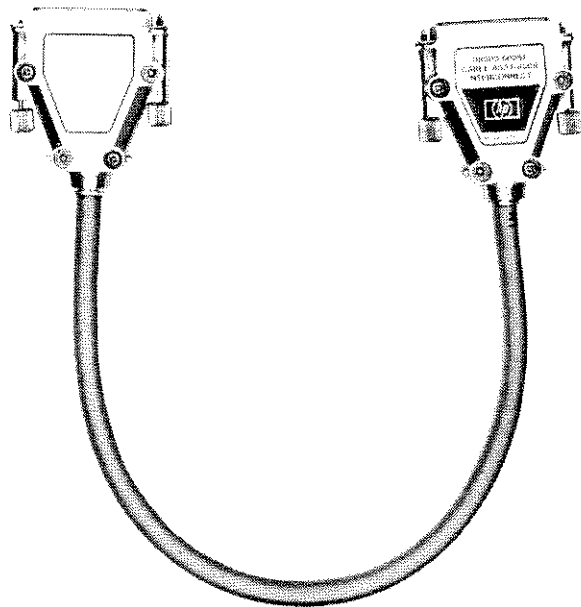

INTERCONNECT CABLE

HP Part Number 08503-60051

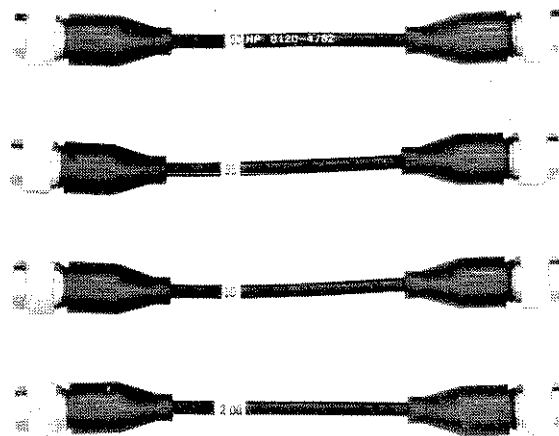

RF CONNECTING CABLES

HP Part Number 8120-4782

Figure 1-1. HP 85046A S-Parameter Test Set with Accessories Supplied

Section 1. General Information

INTRODUCTION

The purpose of this manual is to enable you to use your HP 85046A or HP 85046B S-parameter test set efficiently and confidently. This manual contains both general and specific information. When information applies to both the HP 85046A (the 50 Ω test set) and the HP 85046B (the 75 Ω test set) the name HP 85046A/B is used. To use the HP 85046A/B to perform a specific function (without reading the entire manual), follow the directions in "Using the HP 85046A/B".

This section (1) outlines how to begin using the HP 85046A/B as quickly as possible, (2) describes what instruments are covered by this manual, (3) describes the test set itself, (4) mentions operating precautions, safety considerations and warranty restrictions, (5) lists the additional equipment required and (6) defines and lists the instrument's specifications.

USING THE HP 85046A/B

The HP 85046A/B has been designed to operate specifically with the HP 8753 and 8702 network analyzers.

- To install the instrument, turn to Section 2, Installation.
- To check the proper operation of the HP 85046A/B, see the Operator's Check in Section 3, Operation.
- To verify that the instrument meets its published specifications, turn to Section 4, Performance Tests.
- To troubleshoot the HP 85046A/B, turn to Section 8, Service.

INSTRUMENTS COVERED BY MANUAL

You will find a two-part serial number on the rear panel of the instrument. The first four digits and the letter are the serial number prefix. The last five digits are the sequential suffix which is unique to each test set. The contents of this manual apply directly to test sets with the same serial number prefix as the one(s) on the title page under the heading SERIAL NUMBERS.

If the serial prefix of your test set is not listed on the title page, your instrument differs from those documented in this manual. Most differences are slight, so you may use the information as presented. However for utmost accuracy, refer to the Manual Backdating Changes section of this manual. Significant differences, if any, are documented there.

DESCRIPTION AND OPERATING CHARACTERISTICS OF THE INSTRUMENT

The HP 85046A/B S-parameter test set has been designed to operate with the HP 8753 network analyzer and HP 8702 lightwave component analyzer. The HP 85046A provides a convenient means of measuring reflection and transmission coefficients (scattering parameters) of 50 Ω one-port or two-port devices operating within the frequency range of 300 kHz to 3 GHz. The HP 85046B measures 75 Ω devices within the frequency range of 300 kHz to 2 GHz.

Table 1-1 lists the operating specifications and characteristics of the HP 85046A/B. The test set is illustrated on the cover of this manual and shown in a typical measurement setup in Figure 3-1.

OPTIONS

Option 001

Standard test sets with serial prefix 2936A and below had a mechanical transfer switch. This former option substituted a solid-state switch for the mechanical transfer switch. The solid-state switch allows fast, continuous switching, improved accuracy and increased reliability.

The HP 86389A solid-state switch upgrade kit is available for post-sale installation. Upgrades are performed on a return-to-HP basis. Labor is included. Note that this option is compatible only with these (or higher) firmware revisions: HP 8753B rev 3.00, HP 8753C rev 4.01, or HP 8702B rev 1.00.

For additional information, refer to "Solid-State Switch Operation Considerations" at the end of the Operation section.

Option 009

This option substitutes a mechanical switch for the solid-state transfer switch.

Option 908

This option supplies the test set with the parts required to rack mount it with handles removed. Refer to Section 2 for additional information.

Option 910

This option provides a duplicate test set manual.

Option 913

This option supplies the test set with the parts required to rack mount it with handles. Refer to Section 2 for additional information.

Option W03

This option converts the standard one year warranty to a ninety day on-site warranty. The standard warranty appears on the inside front cover of this manual.

Option W30

This option adds two additional years of return-to-HP support to the standard one year warranty (for a total of three years of return-to-HP support).

ACCESSORIES

Accessories Supplied

Figure 1-1 shows the HP 85046A/B with the accessories supplied:

- Four RF connecting cables
- Interconnect cable

Accessories Available

Calibration and Accessory Kits. The calibration kits listed below contain the components required to characterize the systematic errors of various measurement systems. The components also allow adaptation of devices to various measurement systems.

The accessory kits listed contain the components generally required to measure devices with the types of connectors indicated. Additional information is included in the analyzer manual and the data sheet.

Connector Type	Calibration Kit	Accessory Kit
7 mm Type-N 50 Ω 3.5 mm (SMA) Type-N 75 Ω BNC 50 Ω	HP 85031B HP 85032B HP 85033C HP 85036B	HP 11853A* HP 85033A HP 11854A*

*use with HP 85032B type-N 50 Ω calibration kit

Cable Sets. Use the HP 11857D 7 mm test port return cable set to extend the test ports of the HP 85046A. Use the HP 11857B 75 Ω type-N test port return cable set to extend the test ports of the HP 85046B. Additional information is included in the HP 8753A manual.

Transistor Fixtures. Three transistor fixtures are available to measure the S-parameters of transistors with the HP 85046A:

- HP 11600B* tests TO-18/TO-72 type transistors.
- HP 11602B* tests TO-5/TO-12 type transistors.
- HP 11608A tests 50 Ω stripline transistors.

*use with HP 11858A transistor fixture adapter

OPERATING AND SAFETY PRECAUTIONS

Operating

You need observe only normal precautions in handling and operating the HP 85046A/B. Do not exceed its operating level input of +26 dBm or 30 Vdc.



Electrostatic discharge (ESD) can damage the highly sensitive microcircuits in the HP 85046A/B test sets. ESD damage is most likely to occur as the test sets are connected to or disconnected from the DUT. Protect them by wearing a grounding strap that provides a path to ground of no less than 1 Megohm and no more than 2.5 Megohms. Alternatively, ground yourself by touching the outer shell of any grounded instrument chassis before touching the test port connectors.

Never touch the center contacts of the connectors.

Use a work station equipped with an anti-static surface.

Service

The voltages in this test set do not warrant more than normal caution for operator safety. Nevertheless, service should be performed only by qualified personnel.

ADDITIONAL EQUIPMENT REQUIRED

Table 1-2 lists additional equipment and accessories required for use with the HP 85046A/B. The table notes which items are required to verify the performance of the test set and which are required to operate it. Other equipment may be substituted if its specifications meet or exceed the specifications listed in the critical specifications column.

CONNECTOR CONSIDERATIONS

Movable Test Port

The HP 85046A/B S-parameter test set has one movable test port and one fixed test port. Test port 1 is designed to move in order to accommodate a transistor test fixture.

Scratches on Mating Plane

Note that minor scratches on the mating planes of the connectors are a cause for concern ONLY if they cause degradation in directivity as measured in the directivity performance test.

SPECIFICATIONS

Definitions

The specifications listed in Table 1-1 range from those guaranteed by Hewlett-Packard to those typical of most HP 85046A/B instruments but not guaranteed. Codes in the far right column of Table 1-1 reference a specification definition listed below. These definitions are intended to clarify the extent to which Hewlett-Packard supports the specified performance of the HP 85046A/B.

S-1: This performance parameter is field verifiable using performance tests documented in the service manual.

T: Typical but non-warranted performance characteristics intended to provide information useful in applying the instrument. Typical characteristics are representative of most instruments, though not necessarily tested in each unit and not field tested.

Table 1-1. Specifications

Parameter	HP 85046A	HP 85046B	Code
Frequency Range	300 kHz to 3 GHz	300 kHz to 2 GHz	S-1
Directivity¹: Port 1, 2	≥ 35 dB, 300 kHz to 1.3 GHz ≥ 30 dB, 1.3 GHz to 3 GHz	≥ 35 dB, 300 kHz to 1.3 GHz ≥ 30 dB, 1.3 GHz to 2 GHz	S-1
Port Match¹: R, A & B RF IN	≥ 18 dB, 300 kHz to 1.3 GHz ≥ 13 dB, 1.3 GHz to 3 GHz ≥ 17 dB, 300 kHz to 1.3 GHz ≥ 12 dB, 1.3 GHz to 3 GHz	≥ 18 dB, 300 kHz to 1.3 GHz ≥ 13 dB, 1.3 GHz to 2 GHz ≥ 17 dB, 300 kHz to 1.3 GHz ≥ 12 dB, 1.3 GHz to 2 GHz	S-1
Switch Repeatability	± 0.03 dB	± 0.03 dB	S-1
Effective Source Match¹	≥ 14 dB, 300 kHz to 2 MHz ≥ 20 dB, 2 MHz to 1.3 GHz ≥ 16 dB, 1.3 GHz to 3 GHz	≥ 14 dB, 300 kHz to 2 MHz ≥ 17 dB, 2 MHz to 1.3 GHz ≥ 16 dB, 1.3 GHz to 2 GHz	S-1
Frequency Response¹: Typical Transmission Tracking Magnitude Phase ³ Typical Reflection Tracking Magnitude Phase ³	 ± 1.5 dB ² , 300 kHz to 3 GHz ± 20 deg, 300 kHz to 2 MHz ± 10 deg, 2 MHz to 3 GHz ± 1.5 dB ² , 300 kHz to 3 GHz ± 25 deg, 300 kHz to 2 MHz ± 10 deg, 2 MHz to 3 GHz	 ± 1.5 dB ² , 300 kHz to 2 GHz ± 20 deg, 300 kHz to 2 MHz ± 10 deg, 2 MHz to 2 GHz ± 1.5 dB ² , 300 kHz to 2 GHz ± 25 deg, 300 kHz to 2 MHz ± 10 deg, 2 MHz to 2 GHz	T T

Table 1-1. Specifications (Con't)

Parameter	HP 85046A	HP 85046B	Code
Nominal Insertion Loss	300 kHz to 3 GHz	300 kHz to 2 GHz	T
Standard RF IN to Port 1, 2 RF IN to R RF IN to A, B	12.5 dB +0.5 dB/GHz 18 dB+1.5 dB/GHz 19 dB+1.5 dB/GHz	18 dB +1 dB/GHz 18 dB+1.5 dB/GHz 30 dB+1.5 dB/GHz	
Option 001 RF IN to Port 1, 2 RF IN to R RF IN to A, B	14 dB + 0.5 dB/GHz 18 dB + 1.5 dB/GHz 20.5 dB + 1.5 dB/GHz	19.5 dB + 1 dB/GHz 18 dB + 1.5 dB/GHz 31.5 dB + 1.5 dB/GHz	
Typical Isolation between Port 1 and 2	100 dB	100 dB	T
Impedance: Port 1, 2 RF IN, R, A, B	50Ω 50Ω	75Ω 50Ω	nominal
Connectors: Port 1, 2 RF IN, R, A, B DC bias input:	7 mm 50Ω type-N (f) BNC (f)	75Ω type-N (f) 50Ω type-N (f) BNC (f)	
DC bias input range: Damage level: Power: Dimensions: Weight:	+30 Vdc, +200 mA (fused at 500 mA) (some degradation in RF specifications) 1 watt (+30 dBm) CW RF input +22 Vdc from analyzer via interface cable. 432 mm x 90 mm x 495 mm (17 x 3.5 x 19.5 inches) 6.8 kg (15 lb) net; 9.1 kg (20 lb) shipping		T
1. can be greatly improved with accuracy enhancement techniques 2. deviation from mean value 3. deviation from linear phase			

Table 1-2. Recommended Test Equipment

Instrument	Critical Specifications	Recommended Model	Use*
Network analyzer	no substitute	HP 8753 or 8702	O, P, T
Multimeter	range: DC to 50V	HP 3456A	T
Oscilloscope	100 MHz bandwidth	HP 1740A	T
RF cable set	50Ω type-N, three 24 inch phase-matched, one 34 inch	HP 11851B	P
Calibration kit	load return loss ≥ 46 dB	HP 85032B	P, O
Test set	test port directivity ≥ 30 dB	HP 85044A	P
Type-N loads (2)	return loss ≥ 46 dB	00909-60009	P
Additional Equipment for HP 85046A			
Calibration kit	load return loss ≥ 52 dB	HP 85031B	P, O
Additional Equipment for HP 85046B			
Calibration kit	load return loss ≥ 46 dB	HP 85036B	P, O
Minimum loss pad	return loss ≥ 24 dB	HP 11852B	P
*O=operation; P=performance test; T=troubleshooting			

Section 2. Installation

INTRODUCTION

This section explains how to install the HP 85046A/B test set. The topics covered include initial inspection, environmental considerations, positioning and connecting the test set for use, and packaging the instrument. Figure 2-1 illustrates how to attach flanges to rack-mount the test set with or without handles.

INITIAL INSPECTION

Inspect the shipping container (including cushioning material) for damage. If it is damaged, keep it until you have checked the contents for completeness. The contents are listed in Table 2-1.

In addition, check the test set mechanically and electrically. If the test set and shipping container are undamaged, performing the Directivity performance test in Section 4 should suffice for incoming inspection. If the test set does not pass the performance test, refer to the troubleshooting procedures in Section 8.

If the shipping container is damaged, perform all four electrical performance tests in Section 4. If the test set fails the electrical tests, or is damaged, defective, or incomplete, keep the shipping materials and notify both the carrier and the nearest Hewlett-Packard office. The HP office will arrange for repair or replacement of the test set without waiting for settlement of the claim.

Table 2-1. Components of HP 85046A/B Test Set

Equipment	HP 85046A	HP 85046B
Operating and Service Manual	85046-90001	85046-90001
Interconnect Cable	08503-60051	08503-60051
RF Test Set Cables (4)	8120-4782	8120-4782

ENVIRONMENTAL CONSIDERATIONS

Operation and Storage

For best performance, the HP 85046A/B should be operated in temperatures between 0°C and +55°C with relative humidity between 5% and 95% at 40°C (noncondensing). It may be operated at altitudes up to 4,600 metres (15,000 feet).

The HP 85046A/B may be stored in temperatures from -40°C to +70°C, with relative humidity up to 90% at +65° (non-condensing) and at altitudes up to 15,240 metres (50,000 feet).

PREPARATION FOR USE

Positioning the Test Set

Typically the HP 85046A/B is placed under the network analyzer whether it is rack-mounted or used on a bench. To install the flanges to rack mount the test set (with or without handles) in a standard 19 inch rack, refer to Figure 2-1. The recommended rack is the HP 85043B. Instructions for rack mounting the HP 85046A/B in a system configuration with the analyzer are provided in the analyzer manual and in the HP 85043B system rack manual.

To install the HP 85046A/B for use on a bench, place it under or next to the analyzer. Use an anti-static work surface to lessen the chance of ESD damage.

Connecting the Test Set

Mating Connectors: Ports 1 and 2 of the HP 85046A are precision 7 mm connectors and mate with precision 7 mm connectors. Ports 1 and 2 of the HP 85046B are precision 75 Ω type-N female connectors and mate with precision 75 Ω type-N male connectors. Do not mate type-N 50 Ω connectors to type-N 75 Ω connectors or damage may result.

The RF IN, R, A and B ports of the HP 85046A/B are 50 Ω type-N female connectors which mate with the corresponding precision type-N male connectors whose dimensions conform to US specification MIL-C-39012.

The NETWORK ANALYZER INTERCONNECT connector is a series D 25-contact female connector and mates with the corresponding male connector.

The BIAS CONNECT connectors are 50 Ω BNC female connectors and mate with the corresponding male connectors (UG-88/U).

Power and Control Connections: Power for the HP 85046A/B is supplied by the network analyzer through the interconnect cable. The interconnect cable also transmits control signals between the test set and the network analyzer. Connect the interconnect cable from the NETWORK ANALYZER INTERCONNECT connector on the rear panel of the HP 85046A/B to the TEST SET INTERCONNECT connector on the rear panel of the analyzer.

Signal Path Connections: Place the test set under the analyzer and connect its RF IN port to the analyzer's RF OUT port, R to R, A to A and B to B. Use the four cables supplied with the test set.

To connect the signal path ports with the test set not positioned under the analyzer, use the longer cables of the HP11851B RF cable set. Connect the RF IN port to the RF OUT port with the longer cable. Connect port R to R, A to A and B to B with the three phase-matched cables.

Bias Connections: These connectors supply bias voltages to components under test in a transistor test fixture. Refer to the transistor fixture manual for additional information.

PACKAGING

If reshipping is required, each test set should be repackaged in the original factory package. Containers and materials identical to those used by the factory are available through Hewlett-Packard offices.

Alternatively, comparable packaging materials may be used. Wrap the test set in heavy paper or anti-static plastic. If shipping to an HP Office or Service Center, complete and attach a service tag (in this manual). Use sufficient shock absorbing material on all sides of the HP 85046A/B to provide a thick, firm cushion and prevent movement. Seal the shipping container securely and mark it **FRAGILE**.

In any correspondence with HP, refer to the HP 85046A/B by full model and serial number.

**OPTION 908
RACK MOUNT KIT
WITH HANDLES REMOVED
HP Part Number 5062-3876**

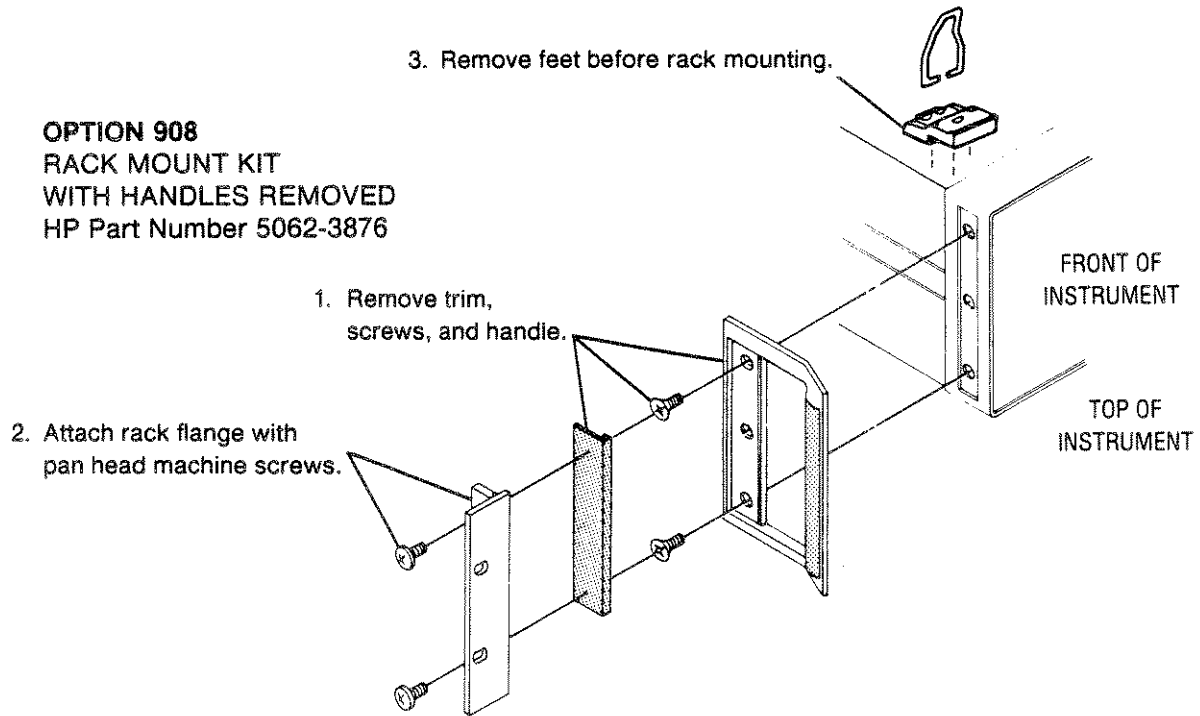

**OPTION 913
RACK MOUNT KIT FOR
INSTRUMENTS WITH PREVIOUSLY
ATTACHED FRONT HANDLES
HP Part Number 5062-4069**

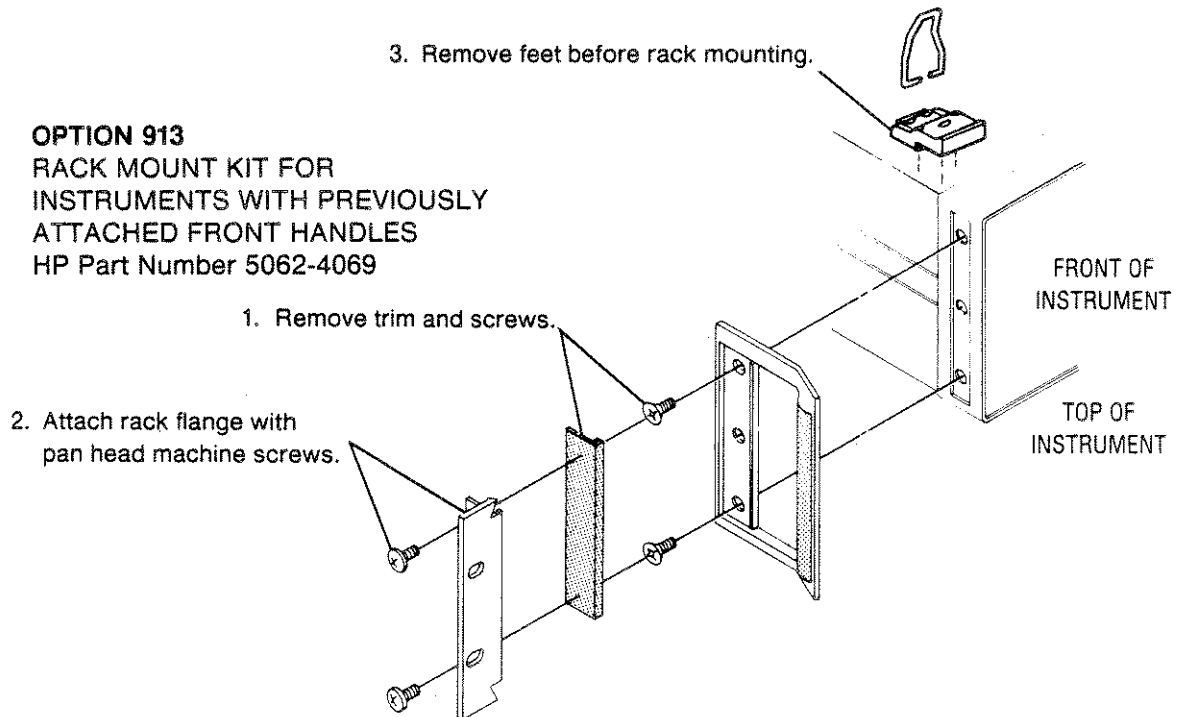

Figure 2-1. Attaching Rack Mounting Hardware

Section 3. Operation

INTRODUCTION

This section illustrates the features and functions of the front and rear panels of the HP 85046A/B (Figures 3-1 and 3-2). Figure 3-3 shows a typical test set measurement setup. Figure 3-4 depicts the RF signal path through the test set for each of the four S-parameter measurements.

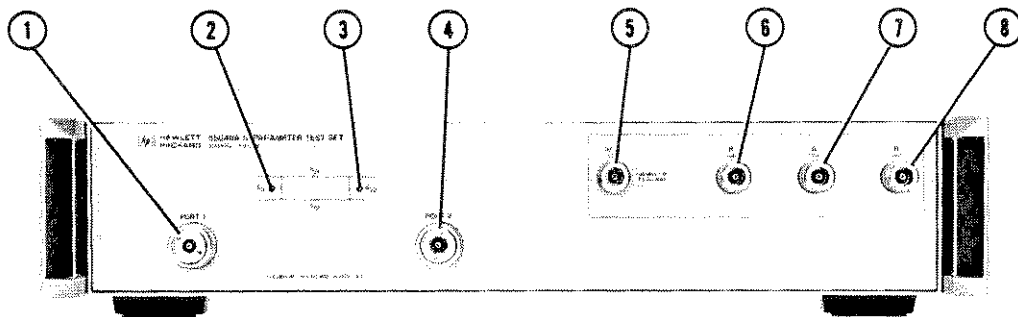

Figure 3-1. Front Panel Features

1. **PORT 1.** The device under test is connected here or to port 2 or to both.



Do not input more than +26 dBm (400 mW) or 30 Vdc to PORT 1 or PORT 2.

2. **S11 S21 Indicator LED.** This indicator, when lit, means that the test set is in the S11 or S21 measurement mode and power is incident from port 1.
3. **S22 S12 Indicator LED.** This indicator, when lit, means that the test set is in the S22 or S12 measurement mode and power is incident from port 2.
4. **PORT 2.** The device under test is connected here or to port 1 or to both.
5. **RF IN.** This RF input connector receives the RF signal from the analyzer RFOUT connector.
6. **R.** This RF connector provides the reference signal to port R of the analyzer.
7. **A.** This RF connector provides an RF input signal to port A of the analyzer from a device under test.
8. **B.** This RF connector provides an RF input signal to port B of the analyzer from a device under test.

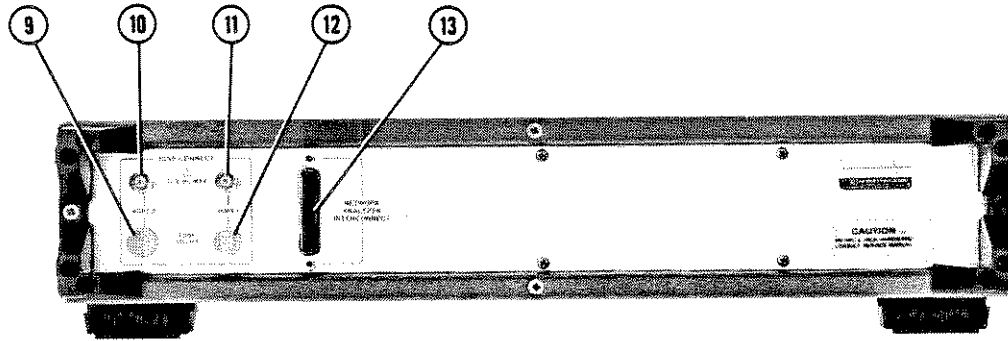

Figure 3-2. Rear Panel Features

9. **PORT 2 FUSE.** This fuse protects the port 2 bias line.
10. **PORT 2 BIAS CONNECTOR.** This connector biases devices connected to port 2 when it is connected to an appropriate source.
11. **PORT 1 BIAS CONNECTOR.** This connector biases devices connected to port 1 when it is connected to an appropriate source.
12. **PORT 1 FUSE.** This fuse protects the port 1 bias line.
13. **NETWORK ANALYZER INTERCONNECT.** This connector supplies the test set with power from the network analyzer and also serves as a bidirectional control path.

OPERATOR'S CHECK

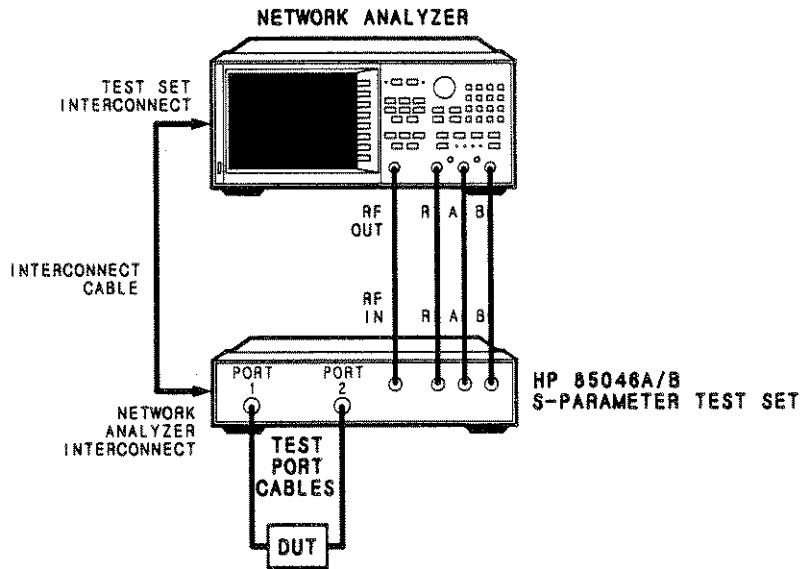

Figure 3-3. Typical Measurement Setup

EQUIPMENT

	HP 85046A	HP 85046B
Network analyzer	HP 8753 or HP 8702	
Interconnect cable	(HP p/n 08503-60051, supplied with test set)	
RF cable set (4)	(HP p/n 8120-4782, supplied with test set)	
Test port cable set	HP 11857D	HP 11857B

PROCEDURE

1. Connect the equipment as shown in Figure 3-3 and turn on the network analyzer but do not connect the DUT.
2. In place of the DUT, connect the cable ends directly.
3. On the analyzer, press **[PRESET]** to set the network analyzer to test PORT 1 of the test set. To check the HP 85046B, press **[STOP] [2] [G/n]** on the network analyzer to limit the frequency to 2 GHz.
4. Press **[MEAS] [S21] [CH 2] [S12]** to set the system to measure S21 on channel 1 and S12 on channel 2. The LEDs on the test set should change when S12 is pressed.

5. Press **[SCALE REF] [REFERENCE POSITION] [9] [x1] [CH 1] [9] [x1]** to move the reference line to the second division from the top for both channels.
6. Press **[MENU] [POWER] [ATTENUATOR PORT 1] [▲]** to increase by 10 dB the attenuation of the signal at port 1. The trace should drop 10 dB (1 division). Press **[▲]** six more times. The trace should drop 10 dB each time.
7. Press **[CH 2] [MENU] [POWER] [ATTENUATOR PORT 2] [▲]** to increase by 10 dB the attenuation of the signal at port 2. The trace should drop 10 dB (1 division). Press **[▲]** six more times. The trace should drop 10 dB each time.
8. This concludes the Operator's Check. In case of difficulty, refer to Section 8, Service.

SOLID-STATE SWITCH OPERATION CONSIDERATIONS

Output power is directed to port 1 or 2 by a transfer switch which may be mechanical or solid-state.

The solid state switch affects the operation of the network analyzer system in these ways:

- Full 2-port calibration: all four forward (S11, S21) and reverse (S12, S22) parameters are updated continuously, which improves the accuracy of full 2-port error correction. This is possible because the solid-state switch can transfer power from port 1 to port 2 continuously. The "Cor" notation on the CRT indicates that all four parameters are being updated.

The mechanical transfer switch does not operate continuously (to prevent its wearing out). After the initial measurement, the analyzer applies power to one port only, as indicated by the "C2" notation. "C2" means only two of the four S-parameters are being updated.

Full 2-port error correction is important in tuning applications, or when a series of devices are connected.

- Nominal insertion loss: increases by 2 to 3 dB. See Table 1 for details.
- Operating noise: lessens because the solid-state switch is not mechanical in operation.
- Reliability: improves because the switch has no moving parts.
- Error messages: "Continuous switching not allowed" is not displayed in dual channel mode unless the channels are set to different attenuator settings.

Upgrade kits are available to enable HP 8753 network analyzers to support solid-state switching.

Model (Firmware Revision)	Kit	Description
HP 8753A (all) HP 8753B (all) HP 8753B (Rev 3.0) HP 8753C (all) HP 8702A (all) HP 8702B (all)	HP 11882A ¹ (Rev 2.01) HP 86388A no upgrade required no upgrade required none available no upgrade required	HP 8753A to B rev 3.0 firmware HP 8753B to rev 3.0 firmware

1. Test set acts like mechanical switch test set unless analyzer is upgraded.

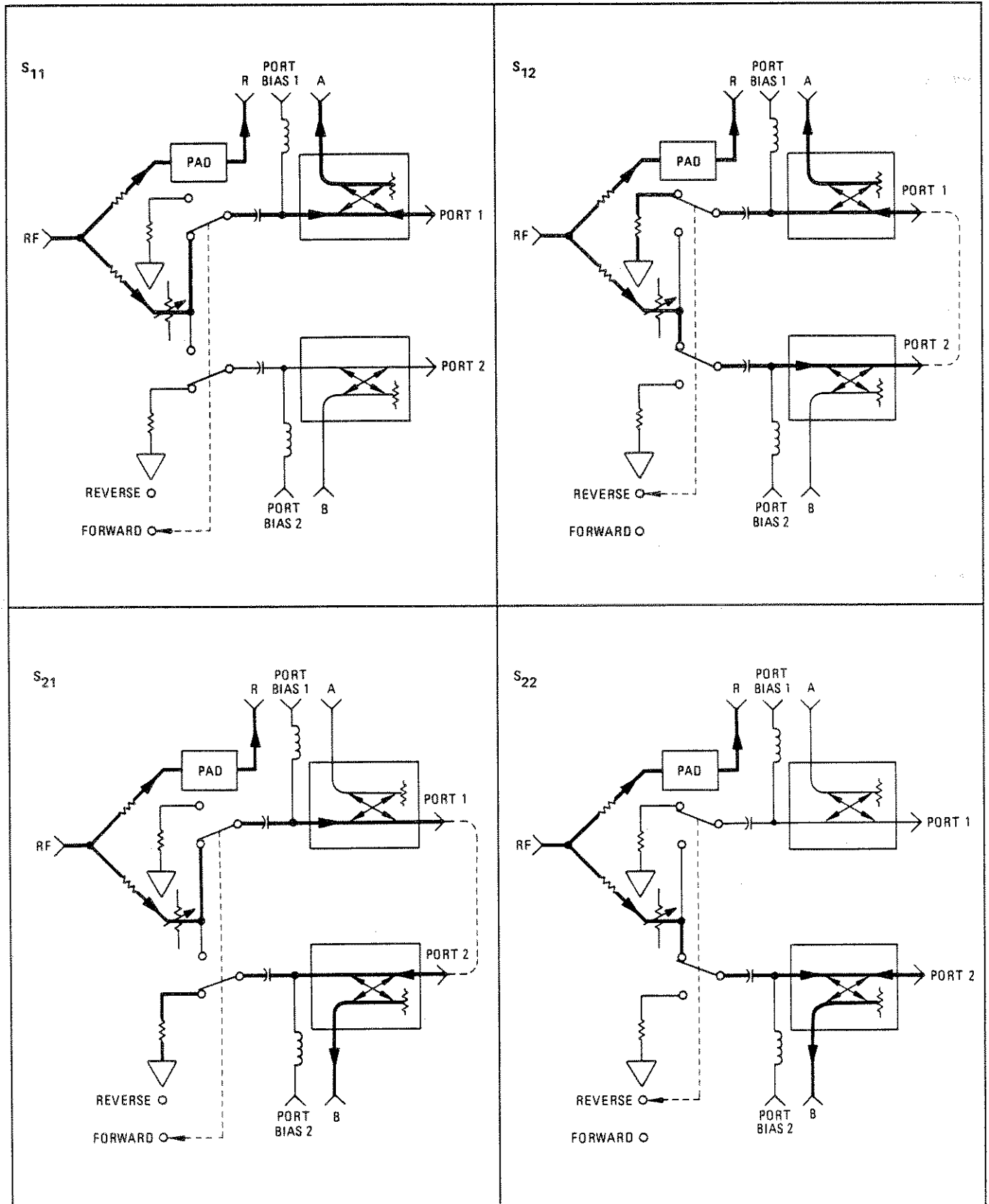

Figure 3-4. RF Signal Path

Section 4. Performance Tests

INTRODUCTION

The procedures in this section test the directivity, port match, switch repeatability and effective source match of the HP 85046A/B test set using the specifications of Table 1-1 as the performance standards. Space to record the specifications and test results is incorporated in Table 4-1. Each test procedure lists the equipment required to test the HP 85046A and HP 85046B. You may substitute test equipment if the substitute equipment meets or exceeds the critical specifications of Table 1-2. Each of the tests can be performed without access to the interior of the instrument.

You may substitute the HP 8702 analyzer for the 8753 in the following tests. In such instances, you may encounter minor variations in key sequences.

PERFORMANCE TEST RECORD

Tabulate the results of the performance tests in Table 4-1. The performance test record provides space to list all of the tested specifications and their acceptable limits. Test results recorded during incoming inspection can be used for comparison with test results obtained after periodic maintenance, troubleshooting or repair.

DIRECTIVITY

DESCRIPTION

Directivity is a measure of the ability of a directive device (in this case the HP 85046A/B) to discriminate between incident and reflected signals. In this procedure it is tested by using the internal bridge to measure the reflection coefficient of a standard termination. Since the return loss of the termination is much greater than the directivity return loss, the measurement made in this procedure is essentially the directivity of the HP 85046A/B. Use the highest quality termination available as that factor determines the accuracy of the procedure.

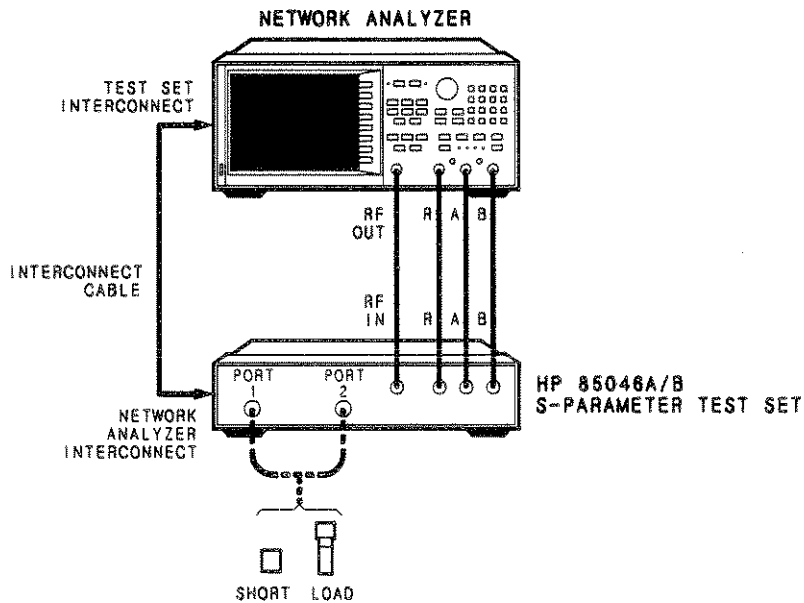

Figure 4-1. Directivity Test Setup

EQUIPMENT

	HP 85046A	HP 85046B
Network analyzer		HP 8753
Interconnect cable	(HP part no. 08503-60051, supplied with test set)	
RF cable set	(HP part no. 8120-4782, supplied with test set)	
Calibration kit	HP 85031B	HP 85036B

PROCEDURE

NOTE: By convention, when the connector sex is indicated in parentheses for a calibration standard, it refers to the sex of the test port connector (not the actual standard). For example, short (f) indicates that the test port connector, not the short circuit connector, is female.

1. Connect the equipment as shown in Figure 4-1 and turn on the analyzer. Allow 30 minutes for warm-up.
2. On the analyzer, press **[PRESET]** to set the network analyzer to test PORT 1 of the test set.
3. To test the HP 85046B only, press **[CAL] [CALKIT] [N 75 ohm]** to select the calibration kit and to set the impedance to 75Ω . Then press **[STOP] [2] [G/n]** to limit the frequency range to 2 GHz.
4. Press **[CAL] [CALIBRATE MENU] [RESPONSE]** to enter the response calibration menu.

NOTE: The calibration standards must be correctly aligned and properly seated in the following steps. Mediocre connections will result in poor directivity measurements. Refer to the Microwave Connector Care manual for additional information.

5. Connect the short supplied with the calibration kit to the test set's port under test when prompted.
6. On the analyzer, press **[SHORT] ([F] for HP 85046B)** for the network analyzer to measure the calibration standard.
7. Press **[DONE: RESPONSE]** after the short has been measured. The status indicator "Cor" should appear on the display.
8. Connect the load supplied with the calibration kit to the HP 85046A/B port under test.
9. On the analyzer, press **[MKR]** and rotate the RPG knob to identify the point of minimum directivity (maximum trace value) from 300 kHz to 1.3 GHz. Enter the value visible in the upper right corner of the display on the Performance Test Record.
10. Rotate the RPG knob to identify the point of minimum directivity (maximum trace value) from 1.3 GHz to 3 GHz (2 GHz for HP 85046B). Enter the value visible in the upper right corner of the display on the Performance Test Record.
11. Press **[MEAS] [REFL: REV S22 (B/R)]** and repeat steps 4 through 10 to test the directivity of PORT 2.
12. If the test set does not meet the directivity specifications of Table 1-1, refer to the Service section of this manual.

PORT MATCH

DESCRIPTION

This procedure uses an HP 85044A to measure the port match of the RF IN, R, A and B ports of the HP 85046A/B.

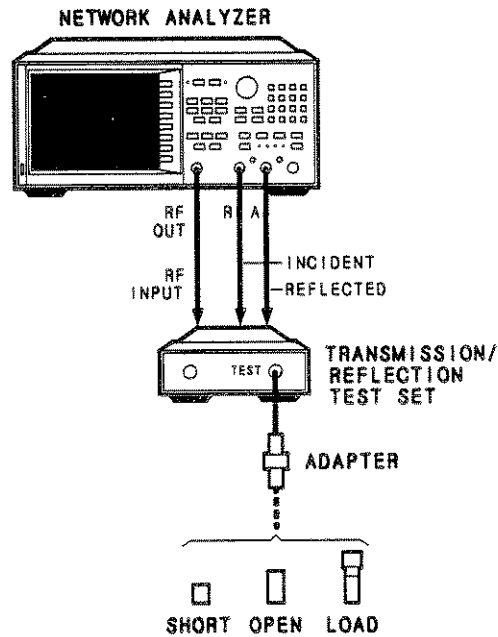

Figure 4-2. HP 85044A Calibration Set-up

EQUIPMENT

	HP 85046A	HP 85046B
Network analyzer	HP 8753	HP 8753
Test set	HP 85044A	HP 85044A
RF cable set	HP 11851B	HP 11851B
Calibration kit	HP 85031B	HP 85032B
Calibration kit	HP 85032B	HP 85036B
Additional loads (2)	HP part no. 00909-60009	HP part no. 00909-60009

PROCEDURE

1. Connect the HP 85044A to the analyzer as shown in Figure 4-2, turn on the analyzer and press **[PRESET]**. To test the HP 85046B, press **[STOP] [2] [G/n]** on the analyzer to limit its upper frequency to 2 GHz.
2. On the analyzer, press **[MENU] [POWER] [1] [0] [x1]** to set the RF power output level to +10 dBm.
3. Press **[AVG] [IF BW] [1] [0] [0] [x1]** to set the IF bandwidth to 100 Hz.
4. Press **[CAL] [CAL KIT] [N 50Ω] [RETURN]** to select the cal kit. Then press **[CALIBRATE MENU] [S11 1-PORT]** to enter the S11 1-port calibration menu. Perform the following steps.

Connect an open to the adapter on the HP 85044A and press **[OPENS] [OPEN (M)]**.

Connect a short to the adapter on the HP 85044A and press **[SHORTS] [SHORT (M)]**.

Connect a load to the adapter on the HP 85044A and press **[LOAD]**.

Press **[DONE 1-PORT CAL]** to conclude the calibration routine. The display should show "Cor" in the status indicator area.

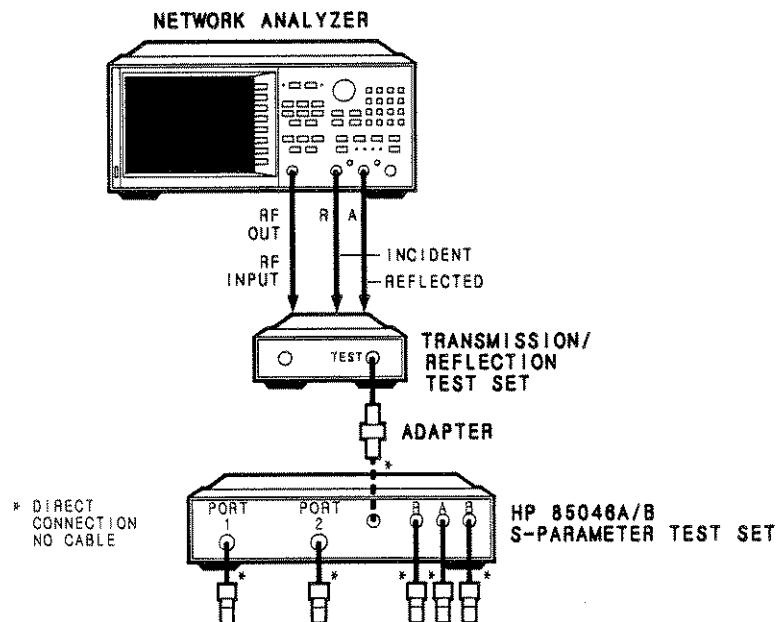

Figure 4-3. Port Match Test Setup

5. Connect a 50 Ω load on ports R, A and B of the HP 85046A/B as shown in Figure 4-3. In addition, to test the port match of the

 HP 85046A: connect one 7 mm 50 Ω load to PORT 1 and one to PORT 2.
 HP 85046B: connect one type-N 75 Ω load to PORT 1 and one to PORT 2.
6. Connect the HP 85044A (through the adapter) to the HP 85046A/B RF IN port. Then press **[MENU] [TRIGGER MENU] [SINGLE]** on the HP 8753A to generate a single sweep.
7. Press **[MKR]** and rotate the RPG knob to identify the point of minimum port match (maximum trace value) from 300 kHz to 1.3 GHz. Enter the value on the Performance Test Record.
8. Rotate the RPG knob to identify the point of minimum port match (maximum trace value) from 1.3 GHz to fmax. Enter the value on the Performance Test Record.
9. To measure the port match return loss of port R, connect the HP 85044A to port R of the HP 85046A/B and connect a load to each of the other three ports. Press **[MENU] [TRIGGER MENU] [SINGLE]** to generate another sweep. Rotate the RPG knob to identify the point of minimum port match from 300 kHz to 1.3 GHz. Enter the value on the Performance Test Record.
10. Rotate the RPG knob to identify the point of minimum port match from 1.3 GHz to fmax. Enter the value on the Performance Test Record.
11. To measure the port match return loss of port A, connect the HP 85044A to port A of the HP 85046A/B and connect a load to each of the other three ports. Press **[SINGLE]** and rotate the RPG knob to identify the point of minimum port match from 300 kHz to 1.3 GHz. Enter the value on the Performance Test Record.
12. Rotate the RPG knob to identify, the point of minimum port match from 1.3 GHz to fmax. Enter the value on the Performance Test Record.
13. To measure the port match return loss of port B, connect the HP 85044A to port B of the HP 85046A/B and connect a load to each of the other three ports. Press **[SINGLE]** and rotate the RPG knob to identify the point of minimum port match from 300 kHz to 1.3 GHz. Enter the value on the Performance Test Record.
14. Rotate the RPG knob to identify the point of minimum port match from 1.3 GHz to fmax. Enter the value on the Performance Test Record.
15. If the results of this test are not within specification, refer to the Service section of this manual.

SWITCH REPEATABILITY

DESCRIPTION

The repeatability of the switch is tested by toggling it ten times and comparing the initial trace to the resultant trace.

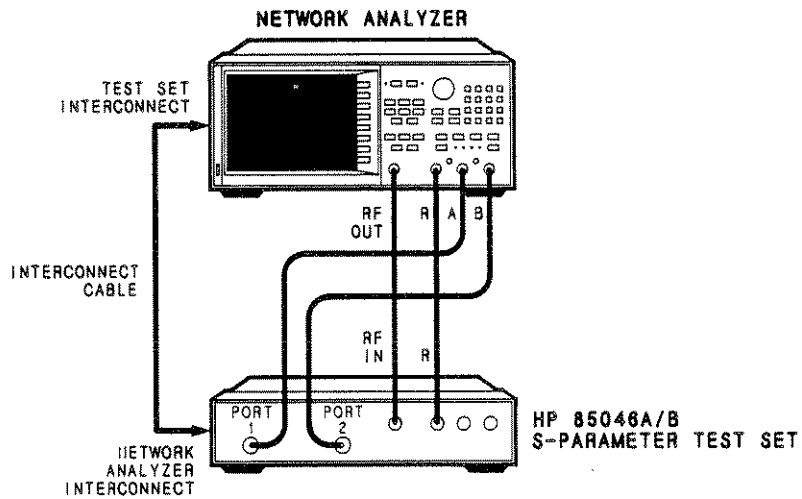

Figure 4-4. Switch Repeatability Test Setup

EQUIPMENT

	HP 85046A	HP 85046B
Network analyzer	HP 8753	HP 8753
RF cable set	HP 11851B	HP 11851B
Adapters (2)	HP part no. 85054-60001*	HP 11852B**
Interconnect cable	(HP part no. 08503-60051, supplied with test set)	
*part of HP 85032B calibration kit		
**minimum loss pad		

PROCEDURE

1. Connect the equipment as shown in Figure 4-4, turn on the analyzer and press **[PRESET]**. To test the HP 85046B, press **[STOP] [2] [G/n]** to limit the frequency sweep to 2 GHz.
2. On the analyzer, press **[AVG] [IF BW] [1] [0] [x1]** to set the IF bandwidth to 10 Hz. Then press **[MENU] [POWER] [1] [0] [x1]** to set the output power level to +10 dBm.
3. Press **[SCALE REF] [.] [0] [1] [x1]** to scale the display. Then press **[MENU] [TRIGGER MENU] [SINGLE]** to generate a single sweep with the network analyzer.
4. At the end of the sweep, press **[DISPLAY] [DATA→MEMORY] [DATA/MEM]** to store the sweep in memory.
5. Then press **[MENU] [TRIGGER MENU] [CONTINUOUS]** to put the analyzer in continuous sweep mode.
6. Press **[MEAS]** and then toggle the HP 85046A/B switch by alternately pressing **[Ref1: REV S22 (B/R)]** and **[Ref1: FWD S11 (A/R)]** ten times on the analyzer. You should be able to hear the switch cycle and see the two LEDs light alternately each time you press the keys. Finish with the instrument in the "Ref1: FWD S11" mode.
7. Press **[MENU] [TRIGGER MENU] [SINGLE]** to generate one more sweep.
8. Note the amount the trace deviates from the reference line and enter that value in the performance test record (S11).
9. Press **[MEAS] [S22] [MENU] [TRIGGER MENU] [SINGLE]** to generate a single sweep in the S22 measurement mode.
10. At the end of the sweep, press **[DISPLAY] [DATA→MEMORY] [DATA/MEM]** to store the sweep in memory.
11. Then press **[MENU] [TRIGGER MENU] [CONTINUOUS]** to put the analyzer in continuous sweep mode.
12. Press **[MEAS]** and then toggle the HP 85046A/B switch by alternately pressing **[S11]** and **[S22]** ten times on the analyzer. You should be able to hear the switch cycle and see the two LEDs light alternately each time you press the keys. Finish with the instrument in the "Ref1: REV S22 (B/R)" mode.
13. Press **[MENU] [TRIGGER MENU] [SINGLE]** to generate one more sweep.
14. Note the amount the trace deviates from the reference line and enter that value in the performance test record (S22).
15. If the results of this test are not within specification, refer to the Service section of this manual.

EFFECTIVE SOURCE MATCH

DESCRIPTION

This procedure determines the effective source match of port 1 and port 2 by examining the calibration coefficient arrays. These arrays are generated during measurement calibration. The arrays are the difference between the measured known calibration standards and ideal modelled data. Thus the calibration coefficient arrays are a direct indication of performance because they represent the systematic errors of the test set.

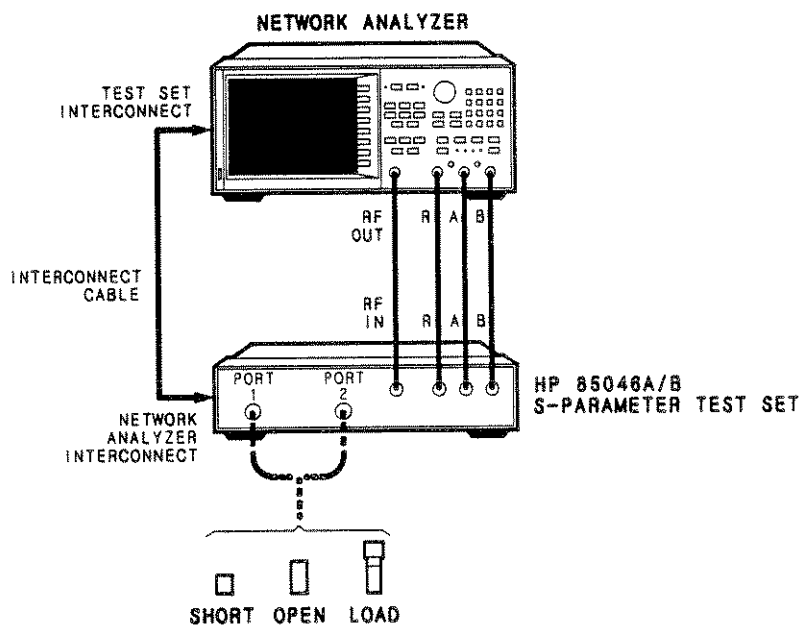

Figure 4-5. Source Match Test Setup

EQUIPMENT

	HP 85046A	HP 85046B
Network analyzer	HP 8753	HP 8753
RF connecting cables	(8120-4782, supplied with test set)	
Interconnect cable	(08503-60051, supplied with test set)	
Calibration kit	HP 85031B	HP 85036B

PROCEDURE

1. Connect the test set to the network analyzer as shown in Figure 4-5, turn on the analyzer and press **[PRESET]**. Allow 30 minutes for warm-up.
2. On the analyzer, press **[MENU] [POWER] [1] [0] [x1] [MENU] [SWEEP TYPE MENU] [LOG FREQ]** to set the network analyzer output power +10 dBm. Then press **[AVG] [IF BW] [1] [0] [0] [x1]** to reduce the IF bandwidth to 100 Hz. If the test set is an HP 85046B, press **[CAL] [CAL KIT] [N 75Ω]** to change the system impedance to 75Ω. Remember that the connector sex indicated in parentheses for a calibration refers to the sex of the test port connector (f).
3. Press **[CAL] [CALIBRATE MENU] [S11 1-PORT]** to enter the S11 1-port calibration menu. Connect, in turn, the three calibration standards (open, short and load) to PORT 1 and press the softkeys as prompted. Then press **[DONE]** to complete the calibration.
4. Press **[SYSTEM] [SERVICE MENU] [TESTS] [3] [3] [x1]** to select the calibration coefficient dumping routine. When the screen indicates "Cal Coef 2", press **[EXECUTE TEST]** to display the calibration coefficients.
5. Press **[MKR]** and rotate the RPG knob to identify the point of minimum source match (maximum trace value) from 300 kHz to 2 MHz. Enter this value on the Performance Test Record.
6. Rotate the RPG knob to identify the point of minimum source match (maximum trace value) from 2MHz to 1.3 GHz. Enter this value on the Performance Test Record.
7. Rotate the RPG knob to identify the point of minimum source match from 1.3 GHz to fmax. Enter this value on the Performance Test Record.
8. To determine the effective source match of PORT 2, press **[CAL] [CALIBRATE MENU] [S221-PORT]**. Connect, in turn, the three calibration standards (open, short and load) to PORT 2 and press the softkeys as prompted. Then press **[DONE]** to complete the calibration.
9. Press **[SYSTEM] [SERVICE MENU] [TESTS] [3] [3] [x1]** to select the calibration coefficient dumping routine. When the screen indicates "Cal Coef 2", press **[EXECUTE TEST]** to display the calibration coefficients.
10. Repeat steps 5 through 7.
11. If the test set does not meet its specifications, refer to Section 8, Service.

Table 4-1 (1 of 2). HP 85046A Performance Test Record

HP 85046A		Serial Number _____	
Date _____		Tested By _____	
Temperature _____		Humidity _____	
Parameter	Specification	Measurement Uncertainty ¹	Test Result
Directivity			
Port 1			
300 kHz to 1.3 GHz	≥ 35 dB	± 1.15 dB	_____
1.3 GHz to 3 GHz	≥ 30 dB	± 0.66 dB	_____
Port 2			
300 kHz to 1.3 GHz	≥ 35 dB	± 1.15 dB	_____
1.3 GHz to 3 GHz	≥ 30 dB	± 0.66 dB	_____
Port Match			
RF IN			
300 kHz to 1.3 GHz	≥ 17 dB	± 0.61 dB	_____
1.3 GHz to 3 GHz	≥ 12 dB	± 0.44 dB	_____
R			
300 kHz to 1.3 GHz	≥ 18 dB	± 0.67 dB	_____
1.3 GHz to 3 GHz	≥ 13 dB	± 0.46 dB	_____
A			
300 kHz to 1.3 GHz	≥ 18 dB	± 0.67 dB	_____
1.3 GHz to 3 GHz	≥ 13 dB	± 0.46 dB	_____
B			
300 kHz to 1.3 GHz	≥ 18 dB	± 0.67 dB	_____
1.3 GHz to 3 GHz	≥ 13 dB	± 0.46 dB	_____
Switch Repeatability			
S11	± 0.03 dB	± 0.006 dB	_____
S22	± 0.03 dB	± 0.006 dB	_____
Effective Source Match			
Port 1			
300 kHz to 2 MHz	≥ 14 dB	± 0.11 dB	_____
2 MHz to 1.3 GHz	≥ 20 dB	± 0.22 dB	_____
1.3 GHz to 3 GHz	≥ 16 dB	± 0.14 dB	_____
Port 2			
300 kHz to 2 MHz	≥ 14 dB	± 0.11 dB	_____
2 MHz to 1.3 GHz	≥ 20 dB	± 0.22 dB	_____
1.3 GHz to 3 GHz	≥ 16 dB	± 0.14 dB	_____

1. Positive and negative (\pm) values typically close but not equal; worst case used.

Table 4-1 (2 of 2). HP 85046B Performance Test Record

HP 85046B		Serial Number _____
Date _____		Tested By _____
Temperature _____		Humidity _____

Parameter	Specification	Measurement Uncertainty ¹	Test Result
Directivity			
Port 1			
300 kHz to 1.3 GHz	≥ 35 dB	± 2.39 dB	_____
1.3 GHz to 2 GHz	≥ 30 dB	± 1.42 dB	_____
Port 2			
300 kHz to 1.3 GHz	≥ 35 dB	± 2.39 dB	_____
1.3 GHz to 2 GHz	≥ 30 dB	± 1.42 dB	_____
Port Match			
RF IN			
300 kHz to 1.3 GHz	≥ 17 dB	± 0.61 dB	_____
1.3 GHz to 2 GHz	≥ 12 dB	± 0.44 dB	_____
R			
300 kHz to 1.3 GHz	≥ 18 dB	± 0.67 dB	_____
1.3 GHz to 2 GHz	≥ 13 dB	± 0.46 dB	_____
A			
300 kHz to 1.3 GHz	≥ 18 dB	± 0.67 dB	_____
1.3 GHz to 2 GHz	≥ 13 dB	± 0.46 dB	_____
B			
300 kHz to 1.3 GHz	≥ 18 dB	± 0.67 dB	_____
1.3 GHz to 2 GHz	≥ 13 dB	± 0.46 dB	_____
Switch Repeatability			
S11	± 0.03 dB	± 0.006 dB	_____
S22	± 0.03 dB	± 0.006 dB	_____
Effective Source Match			
Port 1			
300 kHz to 2 MHz	≥ 14 dB	± 0.45 dB	_____
2 MHz to 1.3 GHz	≥ 17 dB	± 0.95 dB	_____
1.3 GHz to 2 GHz	≥ 16 dB	± 0.85 dB	_____
Port 2			
300 kHz to 2 MHz	≥ 14 dB	± 0.45 dB	_____
2 MHz to 1.3 GHz	≥ 17 dB	± 0.95 dB	_____
1.3 GHz to 2 GHz	≥ 16 dB	± 0.85 dB	_____

1. Positive and negative (±) values typically close but not equal; worst case used.

Section 5. Adjustments

The HP 85046A and 85046B S-parameter test sets have no adjustable components.

Section 6. Replaceable Parts

INTRODUCTION

This section contains information for ordering parts. "Exchange Assemblies Available" describes how to order assemblies which are available on an exchange basis. Figure 6-1 lists the replaceable parts of the logic board assembly. Figure 6-2 identifies the cables and major assemblies of the instrument. Figure 6-3 identifies the miscellaneous parts, mostly attaching hardware, of the test set.

Figure 6-4 is an exploded diagram and list of the cabinet parts. Table 6-1 is a list of manufacturers arranged by code number. Table 6-2 lists upgrade kits.

EXCHANGE ASSEMBLIES AVAILABLE

The directional bridge assembly and the power splitter/directional bridge assembly (see Figure 6-2, 2 of 2) are not field-repairable. They are replaceable on an exchange basis at a considerable cost saving. The assembly includes the RF and DC bias connectors. Note that for replacement purposes only the A3 assembly is stocked. It is the recommended exchange replacement for the A2 and A3 assemblies. Defective assemblies must be returned for credit to realize the cost savings. Thus, assemblies required for spare parts stock must be ordered by the new assembly part number which is included in the replaceable parts list in Section 6 of this manual.

HP part number 5086-6446 is the factory repaired and tested exchange assembly for the HP 85046A directional bridge and splitter/directional bridge.

HP part number 5086-6448 is the factory repaired and tested exchange assembly for the HP 85046B directional bridge and splitter/directional bridge.

HP part number 5086-6539 is the factory repaired and tested exchange assembly for the HP 85046A and 85046B solid state transfer switch.

REPLACEABLE PARTS LISTS

Accompanying each replaceable parts illustration is a replaceable parts list. Each list is arranged in alpha-numerical order by reference designator. The reference designator keys the part listed to the illustration. The first part number listed is HP's part number and may differ from the manufacturer's part number. The check digit serves as an error check of the part number and should be used when ordering a part. Quantity refers to the number of the part in the accompanying illustration. The description is a brief written description of the part and may be used for ordering purposes. Manufacturer's code is a five digit number assigned to each manufacturer (identified in Table 6-1). The manufacturer part number may or may not be the same as the HP part number.

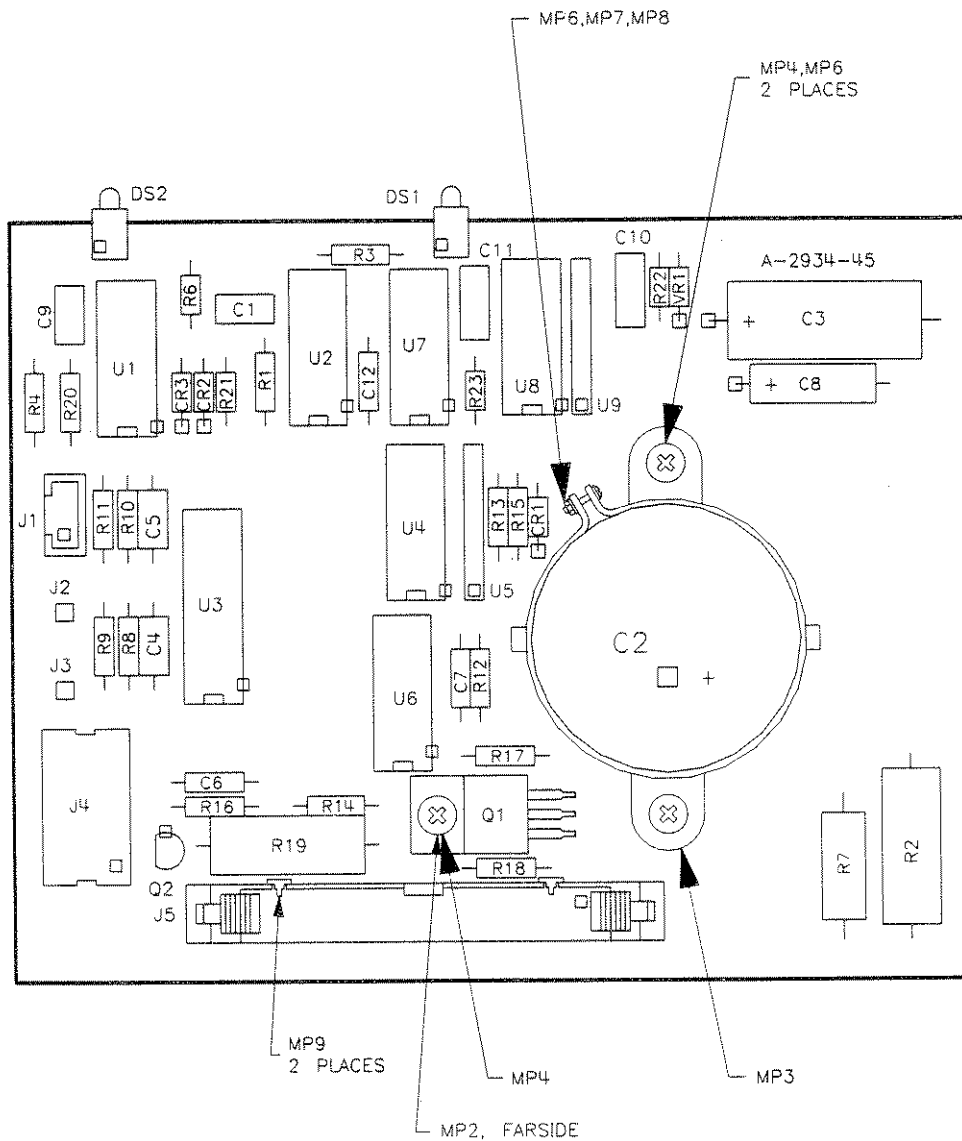

HP Part Number 85046-60051 (Mechanical Transfer Switch)

Figure 6-1 (1 of 4). Logic Board Assembly

Reference Designation	HP Part Number	C D	Qty	Description	Mfr Code	Mfr Part Number
A1	85046-60051	5	1	LOGIC BOARD ASSEMBLY (MECHANICAL TRANSFER SWITCH)	28480	85046-60051
C1	0160-4535	4	1	CERAMIC CAPACITOR 1UF 50V	28480	0160-4535
C2	0180-3759	4	1	CAPACITOR AL 10000UF 35V	28480	0180-3759
C3	0180-2215	5	1	CAPACITOR-FXD 170UF+75-10% 15VDC AL	04200	30D177G0150D2
C4	0160-4833	5	1	CAPACITOR-FXD .022UF ± 10% 100VDC CER	28480	0160-4833
C5	0160-4833	5	1	CAPACITOR-FXD .022UF ± 10% 100VDC CER	28480	0160-4833
C6	0160-4832	4	2	CAPACITOR-FXD .01UF ± 10% 100VDC CER	28480	0160-4832
C7	0160-4832	4	1	CAPACITOR-FXD .01UF ± 10% 100VDC CER	28480	0160-4832
C8	0180-0116	1	1	CAPACITOR-FXD 6.8UF ± 10% 35VDC TA	04200	150D685X9035B2
C9	0160-4535	4	1	CERAMIC CAPACITOR IUF 50V	28480	0160-4535
C10,11	0160-3134	7	2	CERAMIC CAPACITOR .01UF 100V	28480	0160-3134
C12	0160-4832	4	1	CAPACITOR-IXD .01UF ± 10% 100VDC CER	28480	0160-4832
CR1	1901-0050	3	1	DIODE-SWITCHING 80V 200MA 2NS DO-35	00046	1N4150
CR2,3	1901-1098	1	2	DIODE SW 50V .2A	28480	1901-1098
DS1	1990-1134	3	1	LED YELLOW I MCD	04537	551-0305
DS2	1990-1134	3	1	LED YELLOW I MCD	04537	551-0305
J1	1251-6793	4	1	CONN-POST .100-PIN-SPCG 3-CONT	28480	1251-6793
J2	1251-0600	0	1	CONNECTOR-SGL CONT PIN 1.14-MM-BSC-SZ SQ	28480	1251-0600
J3	1251-0600	0	1	CONNECTOR-SGL CONT PIN 1.14-MM-BSC-SZ SQ	28480	1251-0600
J4	1200-1204	5	1	SOCKET-IC 14-CONT DIP DIP-SLDR	24546	1200-1204
J5	1252-1444	0	1	CONN HDR 34 M 2R	28480	1252-1444
MP2	0590-1445	0	3	THREADED INSERT-NUT M3 X 0.5 1.5-MM-LG	28480	0590-1445
MP3	1210-0013	3	1	CLAMP-CAP 1.375-DIA STL	28480	1210-0013
MP4	0515-0430	3	1	MACH SCREW 3.0 6 PN TX	28480	0BD
MP5	2190-0584	0	4	LOCK WASHER HLCL 3.0 MM 3.1-MM-LG	06691	2190-0584
MP6	3050-0891	7	2	FLAT WASHER MTLCL 3.0 MM 3.3-MM-ID	06691	3050-0891
MP7	0515-0664	5	1	MACH SCREW 3.0 12 PN TX	28480	0BD
MP8	0535-0071	0	1	HEX NUT DBLHX M3.0	28480	0BD
MP9	1251-5595	2	2	POLARIZING KEY - POST CONN	04726	0BD
Q1	1853-0479	7	1	TRANSISTOR PNP DARL TO-220AB PD=50W	3L585	72006
Q2	1853-0271	7	1	TRANSISTOR PNP 2N4403 SI TO-92 PD=310MW	28480	1853-0271
R1	0698-3453	2	1	RESISTOR 196K 1% .125W F TC= ± 100	03292	CT4-1/8-TO-1963-F
R2	0757-0818	3	1	RESISTOR 825 OHM 1% .5W TC=0 ± 100	28480	0757-0818
R3,4	0757-0278	9	2	RESISTOR 1.78K 1% .12W	28480	0757-0278
R5				NOT USED		
R6	0698-7261	8	1	RESISTOR 11K 1% .05W	28480	0698-7261
R7	0764-0013	5	1	RESISTOR 56 5% 2W MO TC=0 ± 200	28480	0764-0013
R8	0757-0394	0	1	RESISTOR 51.1 1% .125W F TC=0 ± 100	03292	CT4-1/8-TO-51R1-F
R9	0698-8827	4	1	RESISTOR 1M 1% .125W F TC= ± 100	28480	0698-8827
R10	0757-0394	0	1	RESISTOR 51.1 1% .125W F TC=0 ± 100	03292	CT4-1/8-TO-51R1-F
R11	0698-8827	4	1	RESISTOR 1M 1% .125W F TC= ± 100	28480	0698-8827
R12	0757-0279	0	1	RESISTOR 3.16K 1% .125W TF TC=0 ± 100	24546	CT4-1/8-TO-3161-F
R13	0698-3157	3	1	RESISTOR 19.6K 1% .125W TF TC=0 ± 100	03292	CT4-1/8-TO-1962-F
R14	0757-0401	0	1	RESISTOR 100 1% .125W TF TC=0 ± 100	24546	CT4-1/8-TO-101-F
R15	0757-0462	3	1	RESISTOR 75K 1% .125W TF TC=0 ± 100	03292	CT4-1/8-TO-7502-F
R16	0698-0085	0	1	RESISTOR 2.61K 1% .125W TF TC=0 ± 100	03292	CT4-1/8-TO-2611-F
R17	0757-0442	9	1	RESISTOR 10K 1% .125W TF TC=0 ± 100	03292	CT4-1/8-TO-1002-F
R18	0757-0401	0	1	RESISTOR 100 1% .125W TF TC=0 ± 100	24546	CT4-1/8-TO-101-F
R19	0757-1078	9	1	RESISTOR 1.47K 1% .5W TF TC=0 ± 100	28480	0757-1078
R20	0698-3453	2	1	RESISTOR 196K 1% .125W F TC= ± 100	28480	0698-3453
R21-23	0698-7260	7	3	RESISTOR 10K 1% .05W	28480	0698-7260
U1	1820-3373	7	1	IC MV CMOS/74HC MONOSTBL CLEAR DUAL	03406	MM74HC221AN
U2	1820-3097	2	1	IC74HC08 P4AND	28480	1820-3097
U3	1858-0069	1	1	TRANSISTOR ARRAY 18-PIN PLSTC DIP	04200	ULN-2803A
U4	1820-3146	2	1	IC FF CMOS D-TYPE POS-EDGE-TRIG COM CLK	02037	MC74HC175N
U5	1810-0206	8	1	RESISTOR PACK 10K	28480	1810-0206
U6	1826-0138	8	1	IC393 P4COMPT	28480	1826-0138
U7	1820-6564	4	1	IC74HC7266 EXNOR	28480	1820-6564
U8	1820-3373	7	1	IC MV CMOS/74HC MONOSTBL CLEAR DUAL	03406	MM74HC175N
U9	1810-0206	8	1	RESISTOR PACK 10K	28480	1810-0206
VR1	1902-0041	4	1	DIODE-ZNR 5.11V 5% DO-35 PD=.4W	02237	IN751A

Figure 6-1 (2 of 4). Logic Board Assembly

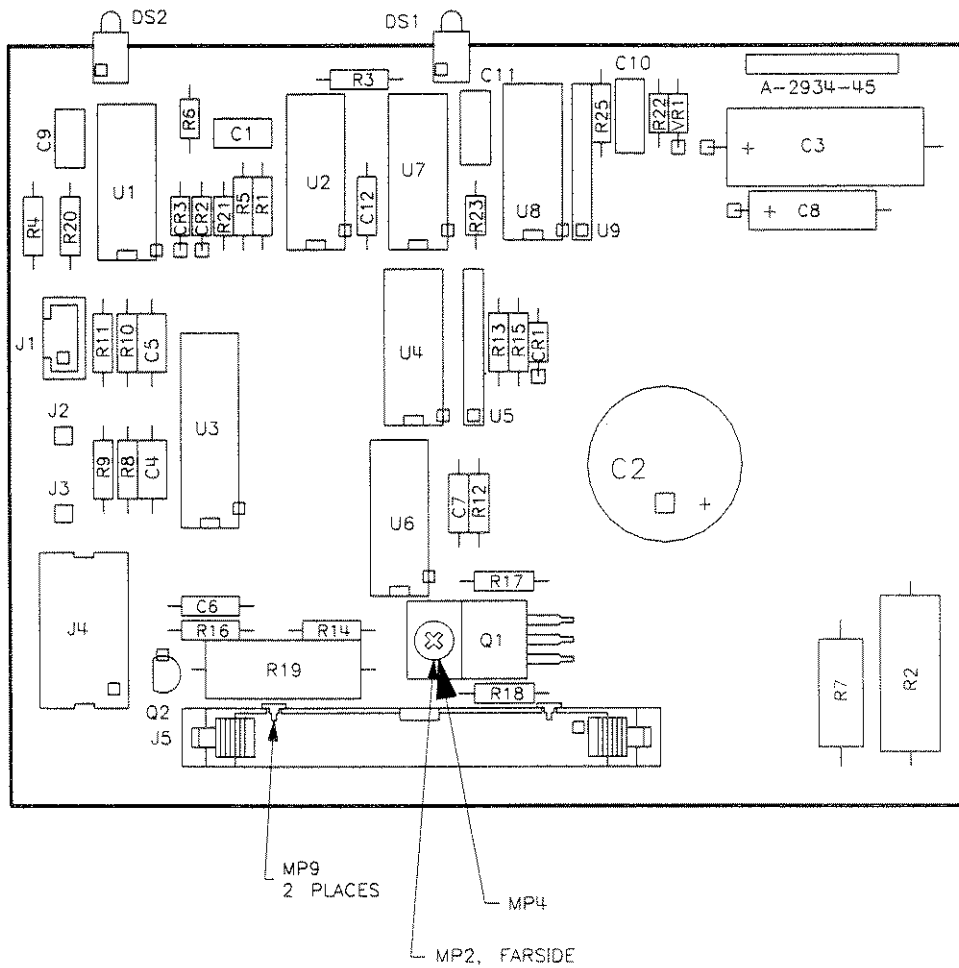

HP Part Number 85046-60016 (Solid-State Transfer Switch)

Figure 6-1 (3 of 4). Logic Board Assembly

Reference Designation	HP Part Number	C D	Qty	Description	Mfr Code	Mfr Part Number
A1	85046-60016	5	1	LOGIC BOARD ASSEMBLY (SOLID-STATE TRANSFER SWITCH)	28480	85046-60016
C1	0160-4535	4	1	CERAMIC CAPACITOR 1UF 50V	28480	0160-4535
C2	0180-3784	5	1	CAPACITOR AL 4700 UF	28480	0180-3784
C3	0180-2215	5	1	CAPACITOR-FXD 170UF +75-10% 15VDC AL	04200	30D177G0150D2
C4	0160-4833	5	1	CAPACITOR-FXD .022UF ± 10% 100VDC CER	28480	0160-4833
C5	0160-4833	5	1	CAPACITOR-FXD .022UF ± 10% 100VDC CER	28480	0160-4833
C6	0160-4832	4	2	CAPACITOR-FXD .01UF ± 10% 100VDC CER	28480	0160-4832
C7	0160-4832	4	2	CAPACITOR-FXD .01UF ± 10% 100VDC CER	28480	0160-4832
C8	0180-0116	1	1	CAPACITOR-FXD 6.8UF ± 10% 35VDC TA	04200	150D685X9035B2
C9	0160-4535	4	1	CERAMIC CAPACITOR 1UF 50V	28480	0160-4535
C10,11	0160-3134	7	2	CERAMIC CAPACITOR .01UF 100V	28480	0160-3134
C12	0160-4832	4	1	CAPACITOR-FXD .01UF ± 10% 100VDC CER	28480	0160-4832
CR1	1901-0050	3	1	DIODE-SWITCHING 80V 200MA 2NS DO-35	00046	1N4150
CR2,3	1901-1098	1	2	DIODE SW 50V .2A	28480	1901-1098
DS1	1990-1134	3	1	LED YELLOW I MCD	04537	551-0305
DS2	1990-1134	3	1	LED YELLOW I MCD	04537	551-0305
J1	1251-6793	4	1	CONN-POST .100-PIN-SPCG 3-CONT	28480	1251-6793
J2	1251-0600	0	1	CONNECTOR-SGL CONT PIN 1.14-MM-BSC-SZ SQ	28480	1251-0600
J3	1251-0600	0	1	CONNECTOR-SGL CONT PIN 1.14-MM-BSC-SZ SQ	28480	1251-0600
J4	1200-1204	5	1	SOCKET-IC 14-CONT DIP DIP-SLDR	24546	1200-1204
J5	1252-1444	0	1	CONN HDR 34 M 2R	28480	1252-1444
MP2	0590-1445	0	3	THREADED INSERT-NUT M3 X 0.5 1.5-MM-LG NOT USED	28480	0590-1445
MP3						
MP4	0515-0430	3	1	MACH SCREW 3.0 6 PN TX	28480	OBD
MP5	2190-0584	0	4	LOCK WASHER HLCL 3.0 MM 3.1-MM-LG	06691	2190-0584
MP6	3050-0891	7	2	FLAT WASHER MTLX 3.0 MM 3.3-MM-ID	06691	3050-0891
MP7	0515-0664	5	1	MACH SCREW 3.0 12 PN TX	28480	OBD
MP8	0535-0071	0	1	HEX NUT DBLHX M3.0	28480	OBD
MP9	1251-5595	2	2	POLARIZING KEY - POST CONN	04726	OBD
Q1	1853-0479	7	1	TRANSISTOR PNP DARL TO-220AB PD=50W	3L585	72006
Q2	1853-0271	7	1	TRANSISTOR PNP 2N4403 SI TO-92 PD=310MW	28480	1853-0271
R1	0698-3453	2	1	RESISTOR 196K 1% .125W F TC=± 100	03292	CT4-1/8-TO-1963-F
R2	0757-0818	3	1	RESISTOR 825 OHM 1% .5W TC=0 ± 100	28480	0757-0818
R3, 4	0757-0278	9	2	RESISTOR 1.78K 1% .12W	S8480	0757-0278
R5	8159-0005	0	1	JUMPER 0 OHM	28480	OBD
R6	0698-7261	8	1	RESISTOR 11K 1% .05W	28480	0698-7261
R7	0698-3613	6	1	RESISTOR 39 OHM .05W	28480	0698-3613
R8	0757-0394	0	1	RESISTOR 51.1 1% .125W F TC=0 ± 100	03292	CT4-1/8-TO-51R1-F
R9	0698-8827	4	1	RESISTOR 1M 1% .125W F TC=± 100	28480	0698-8827
R10	0757-0394	0	1	RESISTOR 51.1 1% .125W F TC=0 ± 100	03292	CT4-1/8-TO-51R1-F
R11	0698-8827	4	1	RESISTOR 1M 1% .125W F TC=± 100	28480	0698-8827
R12	0757-0279	0	1	RESISTOR 3.16K 1% .125W TF TC=0 ± 100	24546	CT4-1/8-TO-3161-F
R13	0698-3157	3	1	RESISTOR 19.6K 1% .125W TF TC=0 ± 100	03292	CT4-1/8-TO-1962-F
R14	0757-0401	0	1	RESISTOR 100 1% .125W TF TC=0 ± 100	24546	CT4-1/8-TO-101-F
R15	0757-0462	3	1	RESISTOR 75K 1% .125W TF TC=0 ± 100	03292	CT4-1/8-TO-7502-F
R16	0698-0085	0	1	RESISTOR 2.61K 1% .125W TF TC=0 ± 100	03292	CT4-1/8-TO-2611-F
R17	0757-0442	9	1	RESISTOR 10K 1% .125W TF TC=0 ± 100	03292	CT4-1/8-TO-1002-F
R18	0757-0401	0	1	RESISTOR 100 1% .125W TF TC=0 ± 100	24546	CT4-1/8-TO-101-F
R19	0757-1078	9	1	RESISTOR 1.47K 1% .5W TF TC=0 ± 100	28480	0757-1078
R20	0698-3453	2	1	RESISTOR 196K 1% .125W F TC=± 100	28480	0698-3453
R21-23	0698-7260	7	3	RESISTOR 10K 1% .05W	28480	0698-7260
R25	8159-0005	0	1	JUMPER 0 OHM	28480	OBD
U1	1820-3373	7	1	IC MV CMOS/74HC MONOSTBL CLEAR DUAL	03406	MM74HC221AN
U2	1820-3097	2	1	IC74HC08 P4AND	28480	1820-3097
U3	1858-0069	1	1	TRANSISTOR ARRAY 18-PIN PLSTC DIP	04200	ULN-2803A
U4	1820-3146	2	1	IC FF CMOS D-TYPE POS-EDGE-TRIG COM CLK	02037	MC74HC175N
U5	1810-0206	8	1	RESISTOR PACK 10K	28480	1810-0206
U6	1826-0138	8	1	IC393 P4COMPT	28480	1826-0138
U7	1820-6564	4	1	IC74HC7266 EXNOR	28480	1820-6564
U8	1820-3373	7	1	IC MV CMOS/74HC MONOSTBL CLEAR DUAL	03406	MM74HC175N
U9	1810-0206	8	1	RESISTOR PACK 10K	28480	1810-0206
VR1	1902-0041	4	1	DIODE-ZNR 5.11V 5% DO-35 PD=.4W	02237	IN751A

Figure 6-1 (4 of 4). Logic Board Assembly

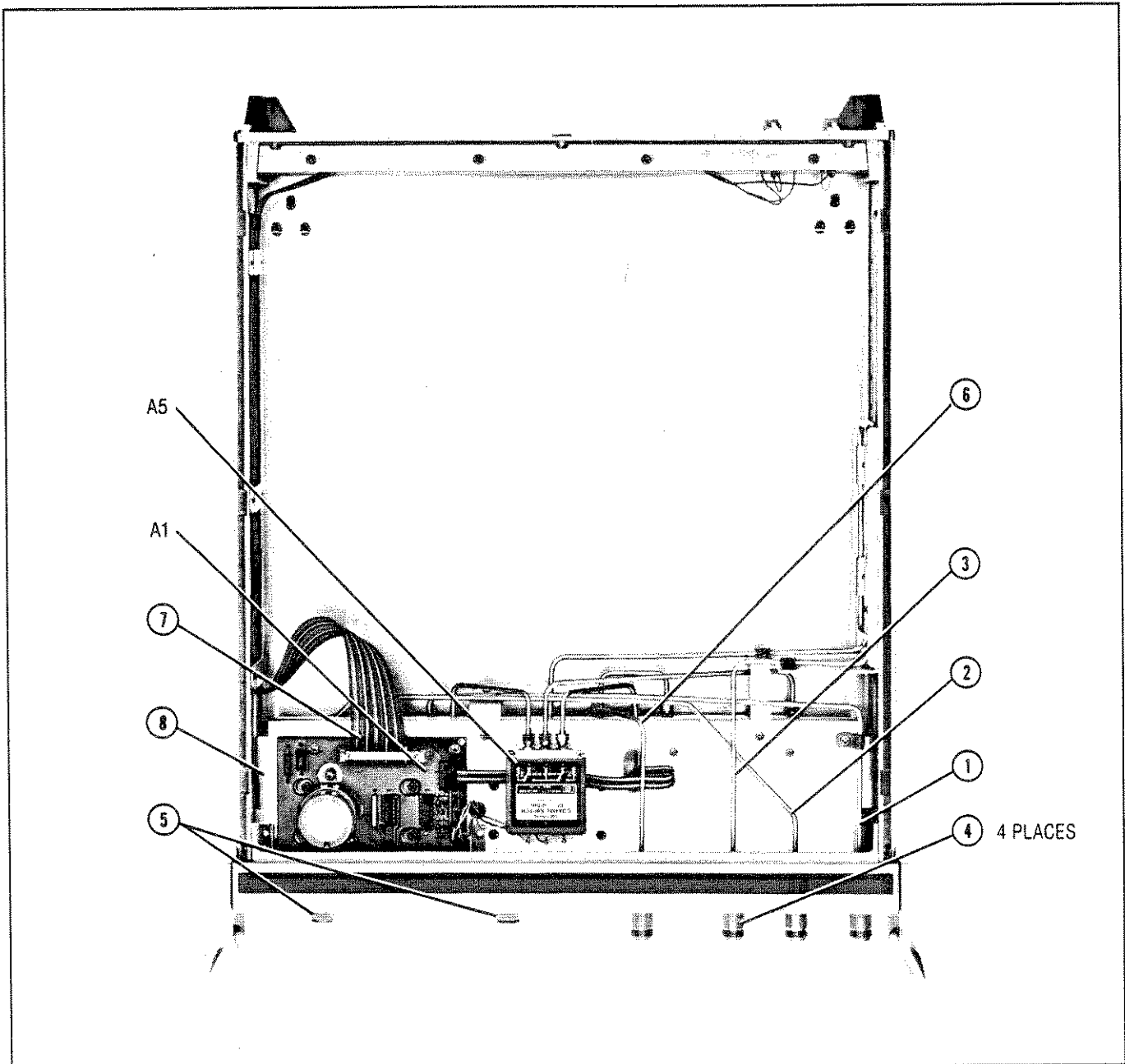

Reference Designation	HP Part Number	C	D	Qty	Description	Mfr Code	Mfr Part Number
A1	5081-8178	6		1	LOGIC ASSEMBLY BOARD (SEE FIGURE 6-1)	28480	5081-8178
A5	5086-7539*			1	TRANSFER SWITCH (COAXIAL), NEW	28480	5086-7539
A5	85046-20002	2		1	SOLID STATE TRANSFER SW, NEW	28480	85046-20002
1	85046-20003	3		1	RF CABLE B	28480	85046-20003
2	85046-20004	4		1	RF CABLE A	28480	85046-20004
3	86290-60005	4		1	RF CABLE R	28480	86290-60005
4				4	TYPE-N (F) CONNECTOR	28480	
5				2	PORT 1 & 2 CONNECTORS, P/O BRIDGE AND BRIDGE/SPLITTER		
6	85046-20005	5		1	RF CABLE RF IN	28480	85046-20005
7	85046-60004	8		1	CABLE RIBBON ASSEMBLY	28480	85046-60004
8	85046-00013	3		1	DECK ASSEMBLY	28480	85046-00013
					* NOTE: REFER TO "EXCHANGE ASSEMBLIES AVAILABLE" FOR REPLACEMENT PARTS.		

Figure 6-2 (1 of 2). Cables and Major Assemblies (top view)

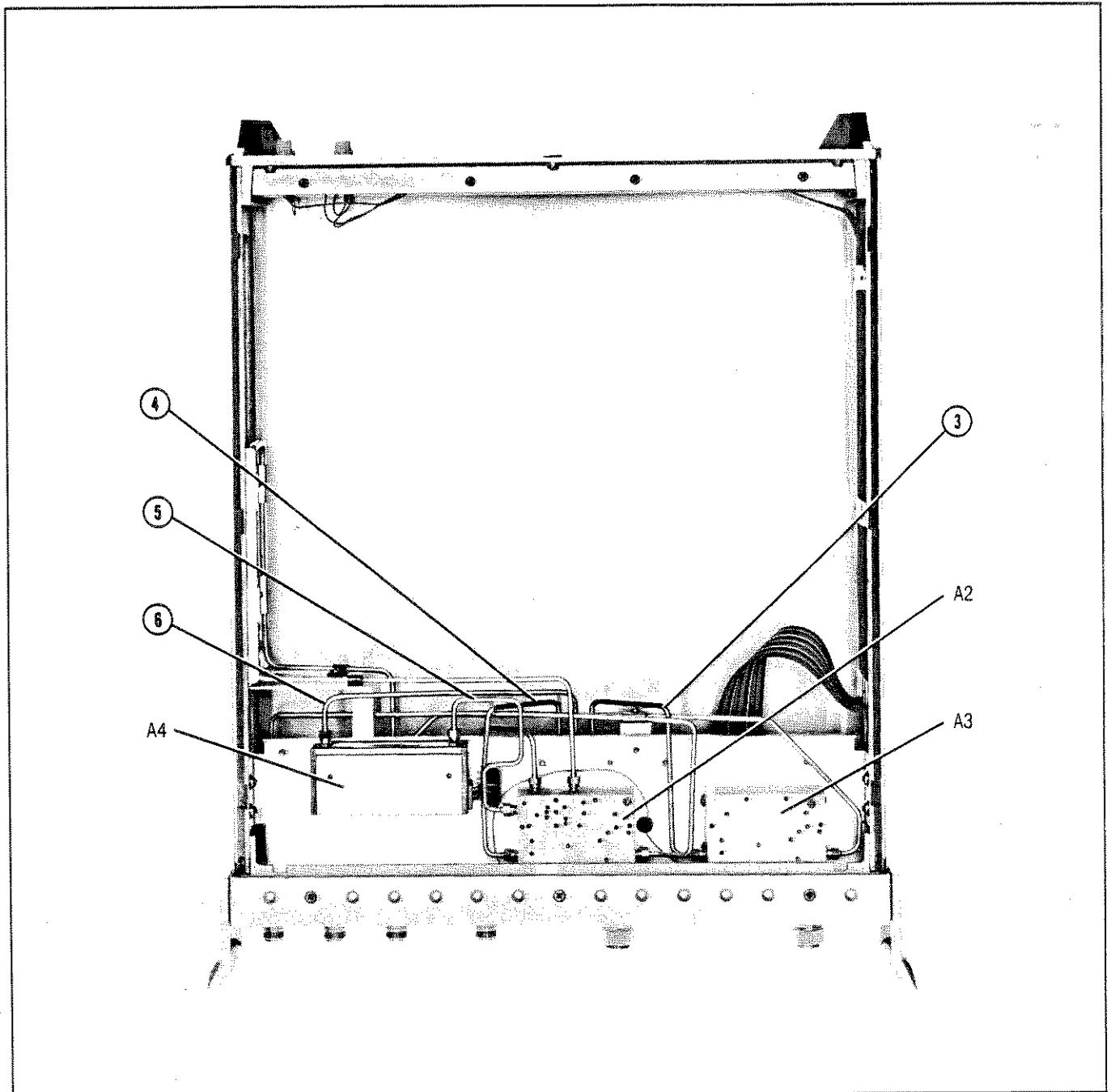

Reference Designation	HP Part Number	C D	Qty	Description	Mfr Code	Mfr Part Number
A2	5086-7446*	6	1	50 OHM BRIDGE/SPLITTER (HP 85046A), NEW	28480	5086-7446
A2	5086-7448*	8	1	75 OHM BRIDGE/SPLITTER (HP 85046B), NEW	28480	5086-7448
A3	5086-7445*	8	1	50 OHM BRIDGE (HP 85046A), NEW	28480	5086-7445
A3	5086-7449*	9	1	75 OHM BRIDGE (HP 85046B), NEW	28480	5086-7449
3	85046-20008	8	1	TRANSFER SWITCH-BRIDGE CABLE	28480	85046-20008
4	85046-20007	7	1	TRANSFER SWITCH-BRIDGE CABLE #2	28480	85046-20007
5	85046-20009	9	1	RF SPLITTER-STEP ATTENUATOR CABLE	28480	85046-20009
6	85046-20006	6	1	STEP ATTENUATOR-TRANSFER SWITCH CABLE	28480	85046-20006
A4	85046-60006	0	1	STEP ATTENUATOR ASSEMBLY	28480	85046-60006

* NOTE: REFER TO "EXCHANGE ASSEMBLIES AVAILABLE" FOR REPLACEMENT PARTS.

Figure 6-2 (2 of 2). Cables and Major Assemblies (bottom view)

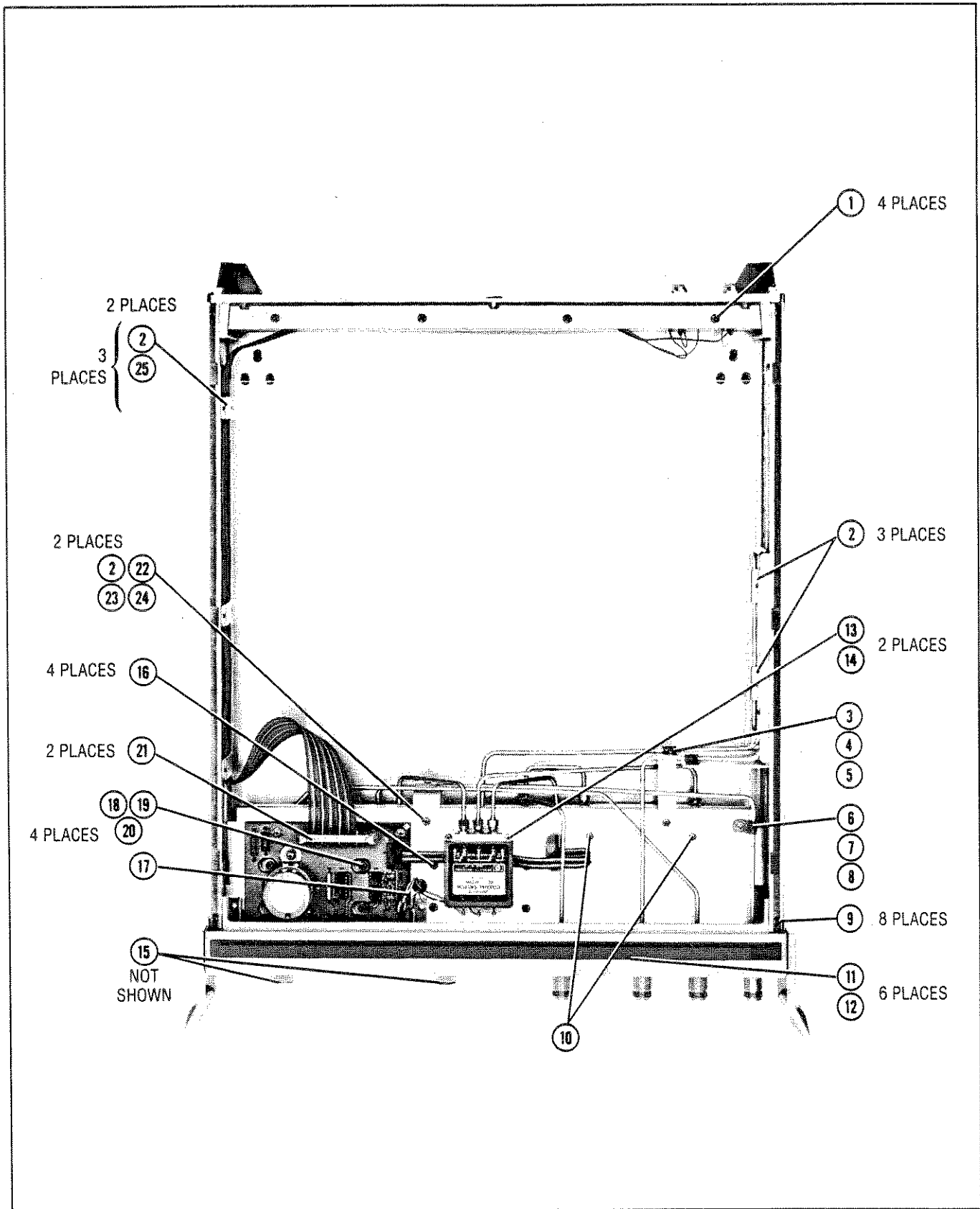
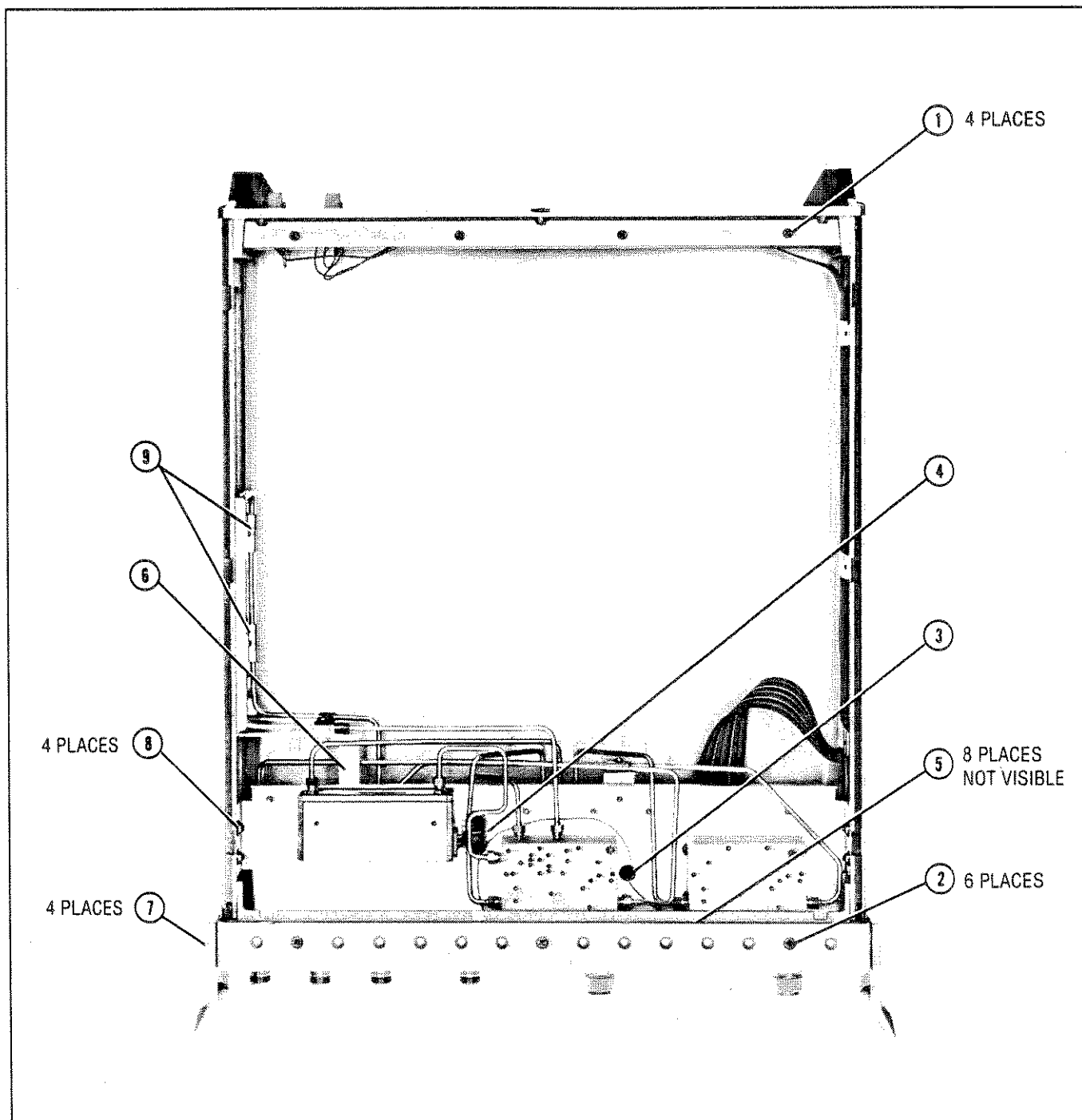

Figure 6-3 (1 of 4). Miscellaneous Parts (top view)

Reference Designation	HP Part Number	C D	Qty	Description	Mfr Code	Mfr Part Number
1	0515-1232	5	4	MACH SCREW M3.5 8MM LONG PAN HEAD	28480	0515-1232
2	0515-0886	3	18	MACH SCREW M3 6MM LONG PAN HEAD	01125	OBD
3	0515-0898	7	2	MACH SCREW M4 6MM LONG	01125	OBD
4	3050-0893	9	2	FLAT WASHER M4	28480	OBD
5	1400-0053	4	2	CABLE CLIP 0.17ID 0.37W	28480	1400-0053
6	0515-1106	2	1	MACH SCREW M4 16MM LONG PAN HEAD	28480	0515-1106
7	3050-0893	9	2	FLAT WASHER M4	06691	OBD
8	1400-0053	4	2	CABLE CLIP 0.17ID 0.37W	28480	1400-0053
9	0515-1331	5	8	MACH SCREW 4.0X FLAT HEAD	28480	OBD
10	2200-0113	4	2	MACH SCREW 440 0.625 LONG PAN HEAD	28480	2200-0113
11	0535-0024	3	6	HEX NUT DBL-CHAM M3.5X0.6 2.8MM-THK	06691	OBD
12	2190-0645	4	6	LOCK WASHER EXT T-B 3.5MM 3.65-MM-ID	04805	OBD
13	0515-0919	3	2	MACH SCREW M3 25MM LONG PAN HEAD	01125	OBD
14	2190-0644	3	2	LOCK WASHER EXT T-B 3.0MM 3.15-MM-ID	04805	OBD
15	1401-0123	1	2	7MM PROTECTIVE CAP (HP 85046A)	05879	OBD
16	2360-0370	3	4	MACH SCREW 6-32 .375-IN-LG PAN-HD POZI	02053	OBD
17	0362-0227	1	1	CONNECTOR-SGL CONT SKT 1.14-MM-BSC-SZ	03418	OBD
18	2360-0370	3	4	MACH SCREW 6-32 .375-IN-LG PAN-HD POZI	02053	OBD
19	3050-0010	2	4	FLAT WASHER 0.147-IN-ID	04719	OBD
20	5021-1755	5	4	SHOULDER WASHER	28480	5021-1755
21	1251-5595	2	2	POLARIZING KEY-POST CONN	04726	OBD
22	85046-00011	1	1	RF CABLE CLAMP #1	28480	85046-00011
23	85046-00012	2	1	RF CABLE CLAMP #2	28480	85046-00012
24	3050-0891	7	2	FLAT WASHER MTLCL 3.0 MM 3.3-MM-ID	06691	OBD
25	1400-0611	5	3	RIBBON CABLE CLAMP	28480	1400-0611

Figure 6-3 (2 of 4). Miscellaneous Parts (top view)



Reference Designation	HP Part Number	C	D	Qty	Description	Mfr Code	Mfr Part Number
1	0515-1232	5	4		MACH SCREW M3.5 8MM LONG PAN HEAD	28480	0515-1232
2	0515-0889	6	6		MACH SCREW M3.5 6MM LONG PAN HEAD	01125	OBD
3	0400-0002	8	1		ROUND GROMMET 0.188ID	04604	OBD
4	0400-0082	8	1		CHANNEL GROMMET	01983	OBD
5	0510-1148	2	8		DRESS PANEL RETAINER	28480	0510-1148
6	85046-00010	0	1		LARGE RF CABLE BRACKET	28480	85046-00010
7	0515-0896	5	4		MACH SCREW M4 10MM LONG	01125	OBD
8	0515-0885	2	4		MACH SCREW M4 8MM LONG PAN HEAD	01125	OBD
9	85046-00009	7	2		RF CABLE CLAMP #3	28480	85046-00009

Figure 6-3 (3 of 4). Miscellaneous Parts (bottom view)

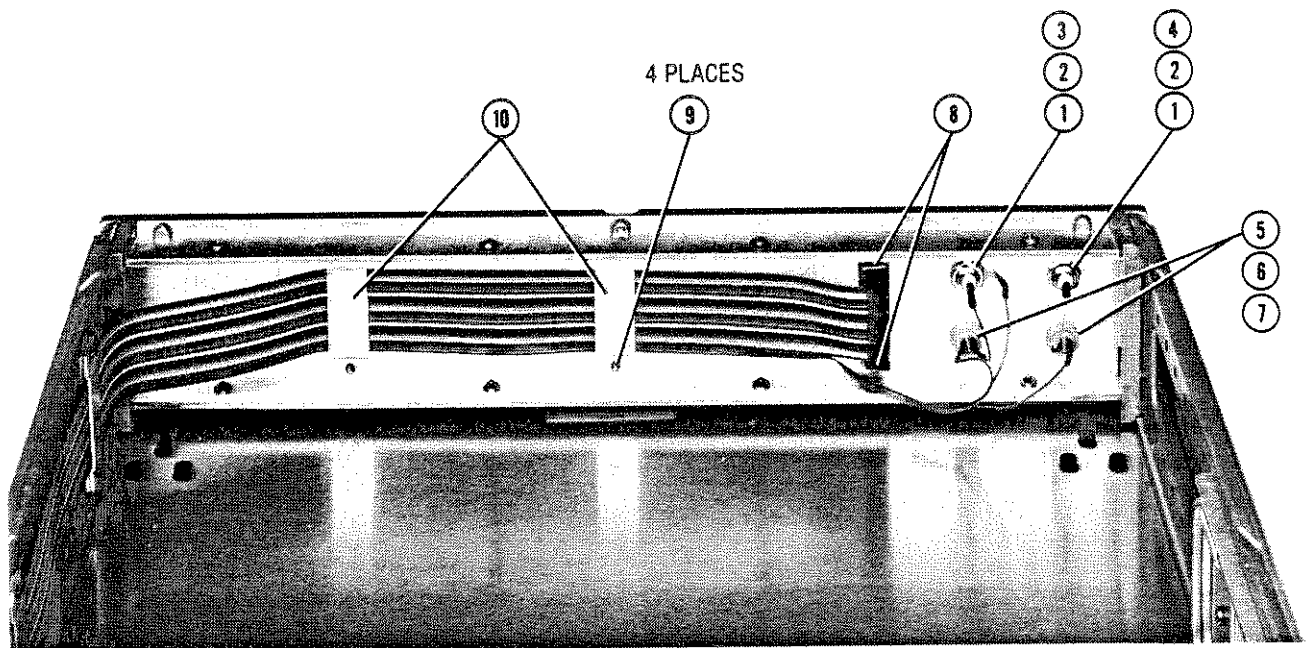

Reference Designation	HP Part Number	C D	Qty	Description	Mfr Code	Mfr Part Number
1	2950-0001	8	2	HEX NUT DBL-CHAM 3/8-32-THD .094-IN-THK	02582	20/4-13
2	1250-0083	1	2	CONNECTOR-RF BNC FEM SGL-HOLE-FR 50-OHM	03316	28JR130-1
3	0360-1632	7	1	SOLDER LUG TERMINAL .37ID	04880	761-3/8
4	2190-0016	3	1	LOCK WASHER INTL T 3/8 IN .377-IN-ID	02440	2190-0016
5	1400-0112	6	2	FUSEHOLDER CAP	04480	1400-0112
6	1400-0110	4	2	FUSEHOLDER-BIPIN SKT 5A 125V	04480	1400-0110
7	2110-0046	1	2	FUSE .5A 125V .25X.27	04480	GMW-1/2
8	1251-2942	7	2	LOCK-SUBMIN D CONN	04486	D20418-2
9	0515-0886	3	6	MACH SCREW M3 X 0.5 6MM-LG PAN-HEAD	01125	0BD
10	85046-00007	5	2	RIBBON CABLE CLAMP	28480	85046-00007

Figure 6-3 (4 of 4). Miscellaneous Parts (inside rear panel)

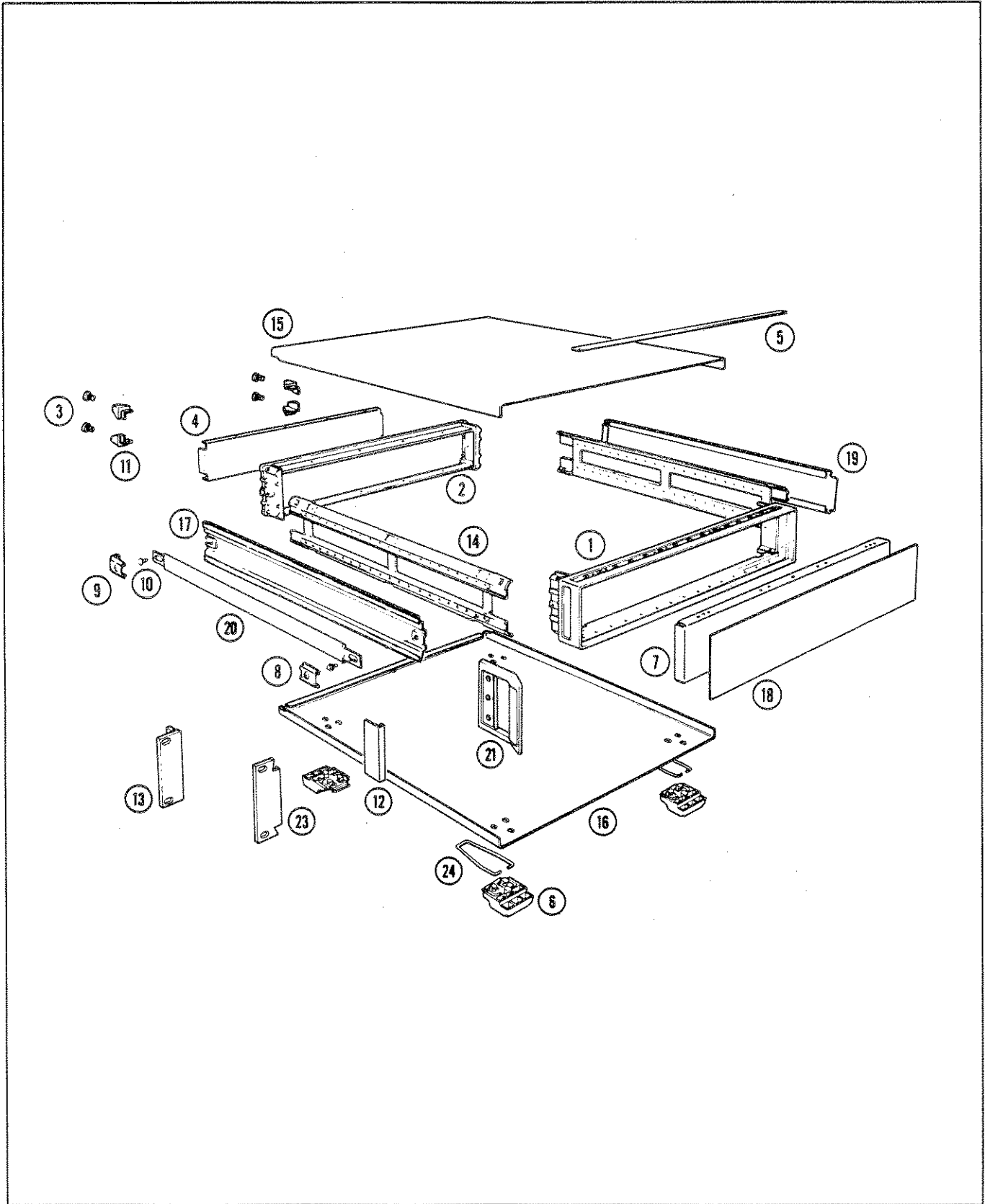

Figure 6-4 (1 of 2). Cabinet Parts

Reference Designation	HP Part Number	C D	Qty	Description	Mfr Code	Mfr Part Number
1	5021-8401	2	1	FRONT FRAME	28480	5021-8401
2	5021-5802	1	1	REAR FRAME	28480	5021-5802
3	0515-1232	5	4	MACH SCREW FOR REAR FOOT	28480	0515-1232
4	85046-00003	1	1	REAR PANEL	28480	85046-00003
5	5041-8802	9	1	TOP TRIM STRIP	28480	5041-8802
6	5041-8801	8	4	BOTTOM FOOT	28480	5041-8801
7	85046-00006	4	1	FRONT SUB-PANEL	28480	85046-00006
8	5041-8819	8	1	STRAP HANDLE FRONT CAP	28480	5041-8819
9	5041-8820	1	1	STRAP HANDLE REAR CAP	28480	5041-8820
10	0515-1132	4	2	STRAP HANDLE RETAINER SCREW	28480	0515-1132
11	5040-8821	2	4	REAR FOOT	28480	5041-8821
12	5021-8495	4	2	FRONT HANDLE TRIM	28480	5021-8495
13	5062-3976	2	1	RACK MOUNT KIT FOR USE WITHOUT HANDLES (INCLUDES TRIM AND ATTACHING HARDWARE)		
14	5021-5832	7	2	SIDE STRUT	28480	5020-5832
15	5062-3735	1	1	TOP COVER	28480	5062-3735
16	5062-3747	5	1	BOTTOM COVER	28480	5062-3747
17	5062-3776	6	1	SIDE COVER (HANDLE SIDE)	28480	5062-3776
18	85046-00001	9	1	FRONT DRESS PANEL (HP 85046A)	28480	85046-00001
	85046-00002	0	1	FRONT DRESS PANEL (HP 85046B)	28480	85046-00002
19	5062-3752	2	1	SIDE COVER (W/O HANDLE)	28480	5062-3752
20	5062-3704	4	1	STRAP HANDLE ASSEMBLY	28480	5062-3704
21	5062-3798	6	2	FRONT HANDLE ASSEMBLY	28480	5062-3798
22	0515-0896	5	4	HANDLE MACH SCREWS (NOT SHOWN)	28480	0515-0896
23	5062-4069	6	1	RACK MOUNT KIT FOR USE WITH HANDLES (INCLUDES ATTACHING HARDWARE)	28480	5062-4069
24	1460-1345	5	2	WIRE FOOT STAND	28480	1460-1345
				TOUCH-UP PAINT		
	6010-1146	6		DOVE GRAY PAINT FOR USE ON FRAME AROUND FRONT PANEL AND PAINTED PORTION OF HANDLES	28480	6010-1146
	6010-1147	7		FRENCH GRAY PAINT FOR USE ON SIDE, TOP, AND BOTTOM COVERS	28480	6010-1147
	6010-1148	8		PARCHMENT GRAY PAINT FOR USE ON RACK MOUNT FLANGES, RACK SUPPORT FLANGES, AND FRONT PANELS	28480	6010-1148

Figure 6-4 (2 of 2). Cabinet Parts

Table 6-1. Manufacturers

Mfr #	Name	Location	
00493	UNITED/NIPPON CHEMI-CON INC	SYRACUSE NY	13200
00746	ROHM CORPORATION	IRVINE CA	92716
00901	KEMET ELEK DIV UNION CARBIDE	GREENVILLE SC	
01074	HOLSWORTHY ELECTRONICS LTD	ENGLAND	
01125	LEWIS SCREW CO	CHICAGO IL	60608
01136	ELCO INDUSTRIES INC	ROCKFORD IL	61101
01380	AMP INC	HARRISBURG PA	17105
01607	ALLEN-BRADLEY CO	MILWAUKEE WI	53204
01963	NYLON MOLDING CORP	SPRINGFIELD NJ	07081
02037	MOTOROLA SEMICONDUCTOR PRODUCTS	PHOENIX AZ	85008
02053	NYLOK-DETROIT CORP	TROY MI	48084
02194	ROBINSON NUGENT INC	FREEPORT NY	11520
02440	THOMSON BREMER DIV VARE	CHICAGO IL	60622
02499	TRW INC BOONE DIV	BOONE NC	28607
02582	CLAROSTAT MFG CO INC	DOVER NH	03820
02634	SPRAGUE ELECT CO SEMICONDUCTOR DIV	CONCORD NH	03301
03316	SPECIALITY CONNECTOR CO INC	GREENWOOD IN	46227
03418	MOLEX PRODUCTS CO	DOWNERS GROVE IL	60515
03981	PENN ENGINEERING AND MFG CORP	DOYLESTOWN PA	18901
04200	SPRAGUE ELECT CO	NORTH ADAMS MA	01247
04486	ITT CANNON ELECTRIC CO	SANTA ANA CA	92702
04604	FEDERAL SCREW PRODUCTS CO	CHICAGO IL	60618
04719	MARWEDEL C W	SAN FRANCISCO CA	94103
04726	3M COMPANY	SAINT PAUL MN	55101
04805	ILLINOIS TOOL WORKS INC	ELGIN IL	60126
04880	ZIERICK MANUFACTURING COMPANY	MOUNT KISCO NY	10549
05879	AMPHENOL SALES DIV OF BUNKER-RAMO	BROADVIEW IL	60153
06691	HOUSE OF METRICS LTD	SPRING VALLEY NY	10977
28480	HEWLETT-PACKARD CO CORPORATE HQ	PALO ALTO CA	94304

Table 6-2. Upgrade Kits

Model Number	Function
HP 86389A	Upgrades test set to solid-state transfer switch; requires HP 8753C or 8753B rev 3.0 firmware or above.
HP 11882A	Upgrades HP 8753A to 8753B rev 3.0 firmware.
HP 86388A	Upgrades HP 8753B to 8753B rev 3.0 firmware.

Section 7. Manual Backdating Changes

INTRODUCTION

This section contains instructions to help you adapt this manual to an instrument with a serial number prefix lower than the one on the title page.

APPLICATION

For instruments with these serial prefixes:

2542A or below: use figures 7-1 and 7-3.

2729A or below: use figures 7-2 and 7-4.

CABINET PARTS

Some early instruments were manufactured with System II cabinet parts. Those instruments had olive green side covers (rather than the current light French grey covers). To determine whether your instrument uses early System II or the current System II Plus parts, inspect the front frame:

- Remove the plastic top trim strip (item 5 of Figure 7-2A).
- If a part number is stamped on the frame, the instrument has System II parts; refer to Figure 7-2A to order cabinet parts.
- If the word METRIC is stamped on the frame, the instrument has System II Plus parts; refer to Figure 6-4 to order cabinet parts.

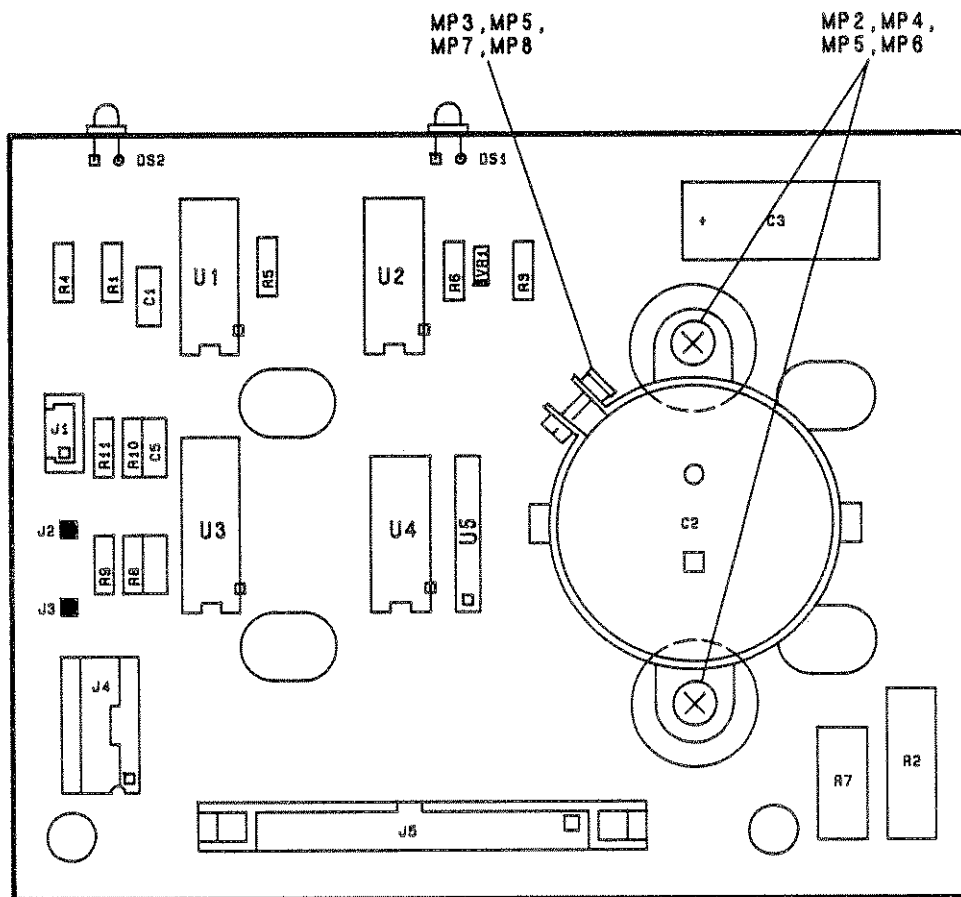

HP Part Number 85046-60001

Figure 7-1 (1 of 2). Logic Board Assembly

Reference Designation	HP Part Number	C D	Qty	Description	Mfr Code	Mfr Part Number
A1	85046-60001	5	1	LOGIC BOARD ASSEMBLY	28480	85046-60001
C1	0160-4535	4	1	CERAMIC CAPACITOR 1UF 50V	00901	C330C105K5R5CA
C2	0180-3759	4	1	CAPACITOR AL 10000UF 35V	28480	0180-3759
C3	0180-2215	5	1	CAPACITOR-FXD 170UF +75-10% 15VDC AL	00493	15T171U10X20M
C4	0160-4833	5	1	CAPACITOR-FXD .022UF ± 10% 100VDC CER	00901	C124C223K1R5CA
C5	0160-4833	5	1	CAPACITOR-FXD .022UF ± 10% 100VDC CER	00901	C124C223K1R5CA
DS1	1990-1134	3	1	LED YELLOW I MCD	28480	1990-1134
DS2	1990-1134	3	1	LED YELLOW I MCD	28480	1990-1134
J1	1251-8793	4	1	CONN-POST .100-PIN-SPCG 3-CONT	01380	3-102202-4
J2	1251-0600	0	1	CONNECTOR-SGL CONT PIN 1.14-MM-BSC-SZ SQ	01136	928-196-004140
J3	1251-0600	0	1	CONNECTOR-SGL CONT PIN 1.14-MM-BSC-SZ SQ	01136	928-196-004140
J4	1200-0508	0	1	SOCKET-IC 14-CONT DIP-SLDR	02194	0002812
J5	1252-1444	0	1	CONN HDR 34 M 2R	28480	1252-1444
MP2	0590-1445	0	2	THREADED INSERT-NUT M3 X 0.5 1.5-MM-LG	03981	KF2-M3-ET
MP3	1210-0013	3	1	CLAMP-CAP 1.375-DIA STL	04200	4586-97A
MP4	0515-0924	0	2	MACH SCREW M3 X 0.5 6MM-LG PAN-HD	01125	0515-0924
MP5	2190-0584	0	3	LOCK WASHER HLCL 3.0 MM 3.1-MM-LG	06691	2190-0584
MP6	3050-0891	7	2	FLAT WASHER MTLCL 3.0 MM 3.3-MM-ID	06691	3050-0891
MP7	0515-0911	5	1	MACH SCREW M3 X 0.5 12MM-LG PAN-HD	01125	0515-0924
MP8	0535-0004	9	1	HEX NUT DBL-CHAM M3 X 0.5 2.4MM-THK	06691	0535-0004
R1	0698-3453	2	1	RESISTOR 261K 1% .125W F TC = ± 100	00746	CRB14
R2	0757-0818	3	1	RESISTOR 825 OHM 1% .5W TC = 0 ± 100	01074	H2
R3	0757-0280	3	1	RESISTOR 1K 1% .125W F TC = ± 100	00746	CRB14
R4	0757-0280	3	1	RESISTOR 1K 1% .125W F TC = ± 100	00746	CRB14
R5	0698-0084	9	1	RESISTOR 2.15K 1% .125W F TC = 0 ± 100	00746	CRB14
R6	0698-0084	9	1	RESISTOR 2.15K 1% .125W F TC = 0 ± 100	00746	CRB14
R7	0764-0013	5	1	RESISTOR 56 5% 2W MO TC = 0 ± 200	02499	GS-3
R8	0757-0394	0	1	RESISTOR 51.1 1% .125W F TC = 0 ± 100	00746	CRB14
R9	0698-8827	4	1	RESISTOR 1M 1% .125W F TC = ± 100	00746	CRB14
R10	0757-0394	0	1	RESISTOR 51.1 1% .125W F TC = 0 ± 100	00746	CRB14
R11	0698-8827	4	1	RESISTOR 1M 1% .125W F TC = ± 100	00746	CRB14
U1	1820-3373	7	1	IC74HC221P2MVR	28480	1820-3373
U2	1820-3171	3	1	IC COMPUTER CMOS/74HC MAGTD 4-BIT	02037	1820-3171
U3	1858-0069	1	1	TRANSISTOR ARRAY 18-PIN PLSTC DIP	02634	ULN-2803A
U4	1820-3146	2	1	IC FF CMOS D-TYPE POS-EDGE-TRIG COM CLK	02037	1858-0069
U5	1810-0231	9	1	NETWORK-RES 8-SIP 2.2K OHM X 7	01607	208A222
VR1	1902-0041	4	1	DIODE-ZNR 5.11V 5% DO-35 PD = .4W	02037	SZ30016-1098

Figure 7-1 (2 of 2). Logic Board Assembly

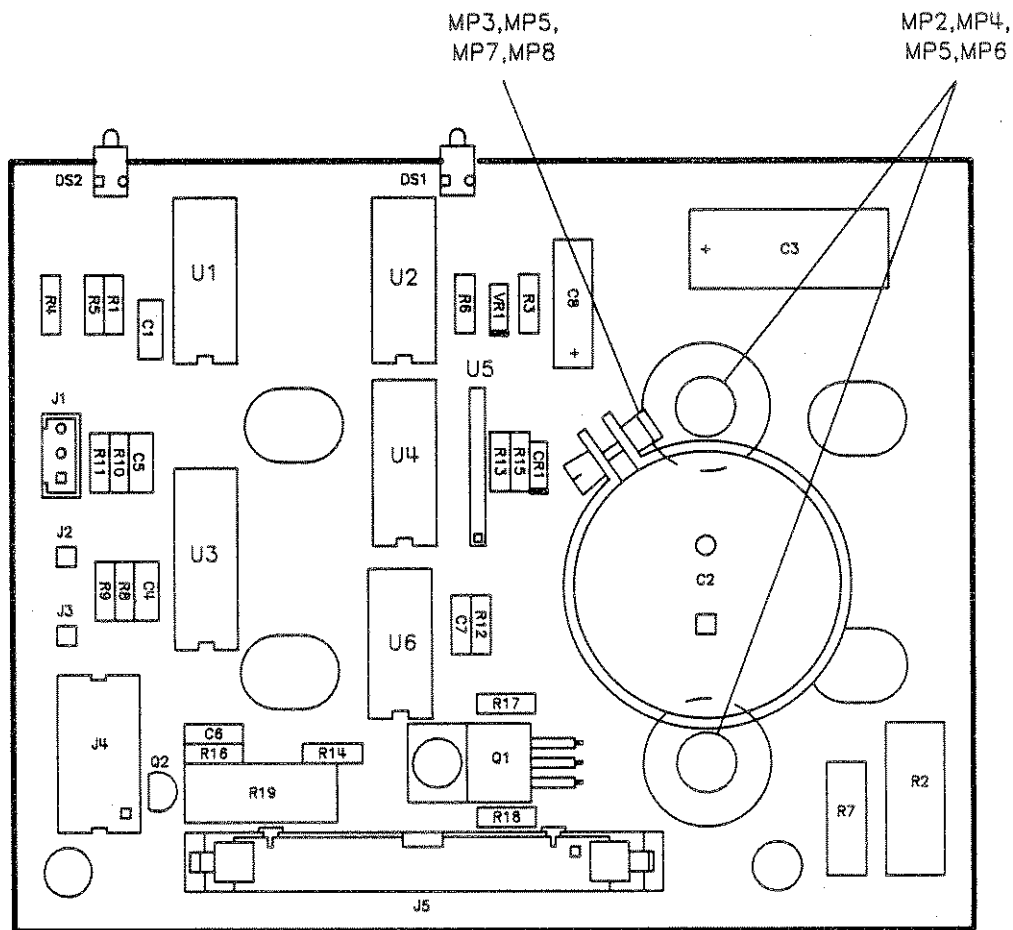

HP Part Number 85046-60011

Figure 7-2 (1 of 2). Logic Board Assembly

Reference Designation	HP Part Number	C D	Qty	Description	Mfr Code	Mfr Part Number
A1	85046-60011	5	1	LOGIC BOARD ASSEMBLY	28480	85046-60001
C1	0160-4535	4	1	CERAMIC CAPACITOR 1UF 50V	28480	0160-4535
C2	0180-3759	4	1	CAPACITOR AL 10000UF 35V	28480	0180-3759
C3	0180-2215	5	1	CAPACITOR-FXD 170UF +75-10% 15VDC AL	04200	30D177G015DD2
C4	0160-4833	5	1	CAPACITOR-FXD .022UF ± 10% 100VDC CER	28480	0160-4833
C5	0160-4833	5	1	CAPACITOR-FXD .022UF ± 10% 100VDC CER	28480	0160-4833
C6	0160-4832	4	2	CAPACITOR-FXD .01UF ± 10% 100VDC CER	28480	0160-4832
C7	0160-4832	4	1	CAPACITOR-FXD .01UF ± 10% 100VDC CER	28480	0160-4832
C8	0180-0116	1	1	CAPACITOR-FXD 6.8UF ± 10% 35VDC TA	04200	150D685X9035B2
CR1	1901-0050	3	1	DIODE-SWITCHING 80V 200MA 2NS DO-35	00046	1N4150
DS1	1990-1134	3	1	LED YELLOW I MCD	04537	551-0305
DS2	1990-1134	3	1	LED YELLOW I MCD	04537	551-0305
J1	1251-6793	4	1	CONN-POST .100-PIN-SPCG 3-CONT	28480	1251-6793
J2	1251-0600	0	1	CONNECTOR-SGL CONT PIN 1.14-MM-BSC-SZ SQ	28480	1251-0600
J3	1251-0600	0	1	CONNECTOR-SGL CONT PIN 1.14-MM-BSC-SZ SQ	28480	1251-0600
J4	1200-1204	5	1	SOCKET-IC 14-CONT DIP DIP-SLDR	24546	1200-1204
J5	1252-1444	0	1	CONN HDR 34 M 2R	28480	1252-1444
MP2	0590-1445	0	3	THREADED INSERT-NUT M3 X 0.5 1.5-MM-LG	28480	0590-1445
MP3	1210-0013	3	1	CLAMP-CAP 1.375-DIA STL	28480	1210-0013
MP4	0515-0924	0	3	MACH SCREW M3 X 0.5 6MM-LG PAN-HD	01125	0515-0924
MP5	2190-0584	0	4	LOCK WASHER HLCL 3.0 MM 3.1-MM-LG	06691	2190-0584
MP6	3050-0891	7	2	FLAT WASHER MTLCL 3.0 MM 3.3-MM-ID	06691	3050-0891
MP7	0515-0911	5	1	MACH SCREW M3 X 0.5 12MM-LG PAN-HD	01125	0515-0911
MP8	0535-0004	9	1	HEX NUT DBL-CHAM M3 X 0.5 2.4MM-THK	06691	0535-0004
MP9	1251-5595	2	2	POLARIZING KEY - POST CONN	04726	0BD
R1	0698-3453	2	1	RESISTOR 196K 1% .125W F TC = ± 100	03292	CT4-1/8-TO-1963-F
R2	0757-0818	3	1	RESISTOR 825 OHM 1% .5W TC = 0 ± 100	28480	0757-0818
R3	0757-0278	9	1	RESISTOR 1.78K 1% .125W F TC = ± 100	03292	CT4-1/8-TO-1001-F
R4	0757-0278	9	1	RESISTOR 1.78K 1% .125W F TC = ± 100	03292	CT4-1/8-TO-1001-F
R5	0698-0084	9	1	RESISTOR 2.15K 1% .125W F TC = 0 ± 100	03292	CT4-1/8-TO-2151-F
R6	0698-0084	9	1	RESISTOR 2.15K 1% .125W F TC = 0 ± 100	03292	CT4-1/8-TO-2151-F
R7	0764-0013	5	1	RESISTOR 56 5% 2W MO TC = 0 ± 200	28480	0764-0013
R8	0757-0394	0	1	RESISTOR 51.1 1% .125W F TC = 0 ± 100	03292	CT4-1/8-TO-51R1-F
R9	0698-8827	4	1	RESISTOR 1M 1% .125W F TC = ± 100	28480	0698-8827
R10	0757-0394	0	1	RESISTOR 51.1 1% .125W F TC = 0 ± 100	03292	CT4-1/8-TO-51R1-F
R11	0698-8827	4	1	RESISTOR 1M 1% .125W F TC = ± 100	28480	0698-8827
R12	0757-0279	0	1	RESISTOR 3.16K 1% .125W TF TC = 0 ± 100	24546	CT4-1/8-TO-3161-F
R13	0698-3157	3	1	RESISTOR 19.6K 1% .125W TF TC = 0 ± 100	03292	CT4-1/8-TO-1962-F
R14	0757-0401	0	1	RESISTOR 100 1% .125W TF TC = 0 ± 100	24546	CT4-1/8-TO-101-F
R15	0757-0462	3	1	RESISTOR 75K 1% .125W TF TC = 0 ± 100	03292	CT4-1/8-TO-7502-F
R16	0698-0085	0	1	RESISTOR 2.61K 1% .125W TF TC = 0 ± 100	03292	CT4-1/8-TO-2611-F
R17	0757-0442	9	1	RESISTOR 10K 1% .125W TF TC = 0 ± 100	03292	CT4-1/8-TO-1002-F
R18	0757-0401	0	1	RESISTOR 100 1% .125W TF TC = 0 ± 100	24546	CT4-1/8-TO-101-F
R19	0757-1078	9	1	RESISTOR 1.47K 1% .5W TF TC = 0 ± 100	28480	0757-1078
Q1	1853-0479	7	1	TRANSISTOR PNP DARL TO-220AB PD = 50W	3L585	72006
Q2	1853-0271	7	1	TRANSISTOR PNP 2N4403 SI TO-92 PD = 310MW	28480	1853-0271
U1	1820-3373	7	1	IC MV CMOS/74HC MONOSTBL CLEAR DUAL	03406	MM74HC221AN
U2	1820-3171	3	1	IC COMPUTER CMOS/74HC MAGTD 4-BIT	02037	MC74HC85N
U3	1858-0069	1	1	TRANSISTOR ARRAY 18-PIN PLSTC DIP	04200	ULN-2803A
U4	1820-3146	2	1	IC FF CMOS D-TYPE POS-EDGE-TRIG COM CLK	02037	MC74HC175N
U5	1810-0231	9	1	NETWORK-RES 8-SIP 2.2K OHM X 7	01607	208A222
U6	1826-0138	8	1	IC COMPARATOR GP QUAD 14-DIP-C PKG	28480	1826-0138
VR1	1902-0041	4	1	DIODE-ZNR 5.11V 5% DO-35 PD = 4W	02237	IN751A

Figure 7-2 (2 of 2). Logic Board Assembly

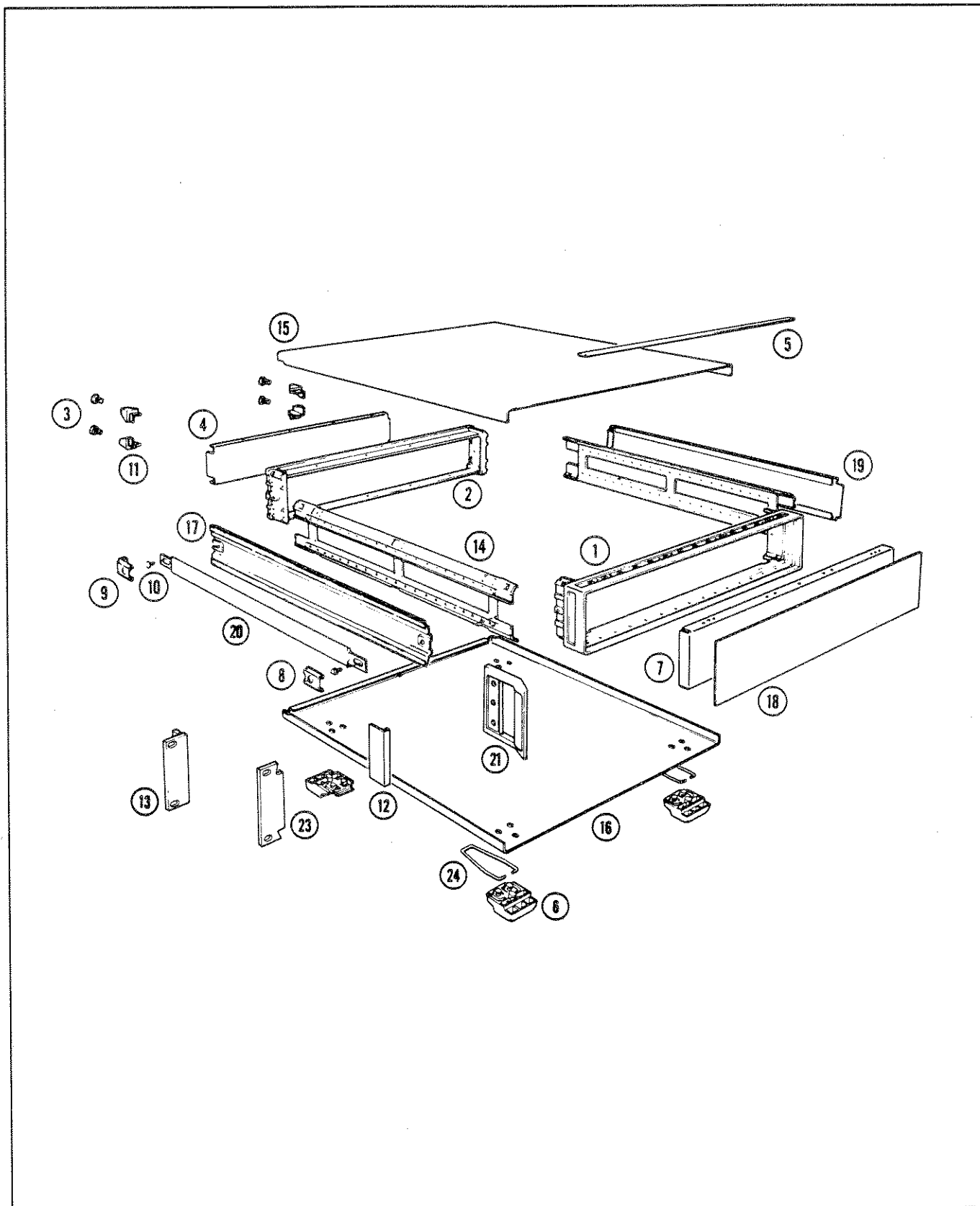

Figure 7-2A (1 of 2). Cabinet Parts

Reference Designation	HP Part Number	C D	Qty	Description	Mfr Code	Mfr Part Number
1	5021-8401	2	1	FRONT FRAME	28480	5021-8401
2	5021-5802	1	1	REAR FRAME	28480	5021-5802
3	0515-1232	5	4	MACH SCREW FOR REAR FOOT	28480	0515-1232
4	85046-00003	1	1	REAR PANEL	28480	85046-00003
5	5041-8802	9	1	TOP TRIM STRIP	28480	5041-8802
6	5041-8801	8	4	BOTTOM FOOT	28480	5041-8801
7	85046-00006	4	1	FRONT SUB-PANEL	28480	85046-00006
8	5041-8819	8	1	STRAP HANDLE FRONT CAP	28480	5041-8819
9	5041-8820	1	1	STRAP HANDLE REAR CAP	28480	5041-8820
10	0515-1132	4	2	STRAP HANDLE RETAINER SCREW	28480	0515-1132
11	5040-8821	2	4	REAR FOOT	28480	5041-8821
12	5021-8495	4	2	FRONT HANDLE TRIM	28480	5021-8495
13	5062-3976	2	1	RACK MOUNT KIT FOR USE WITHOUT HANDLES (INCLUDES TRIM AND ATTACHING HARDWARE)		
14	5021-5832	7	2	SIDE STRUT	28480	5020-5832
15	5062-3735	1	1	TOP COVER	28480	5062-3735
16	5062-3747	5	1	BOTTOM COVER	28480	5062-3747
17	5062-3776	6	1	SIDE COVER (HANDLE SIDE)	28480	5062-3776
18	85046-00001	9	1	FRONT DRESS PANEL (HP 85046A)	28480	85046-00001
	85046-00002	0	1	FRONT DRESS PANEL (HP 85046B)	28480	85046-00002
19	5062-3752	2	1	SIDE COVER (W/O HANDLE)	28480	5062-3752
20	5062-3704	4	1	STRAP HANDLE ASSEMBLY	28480	5062-3704
21	5062-3798	6	2	FRONT HANDLE ASSEMBLY	28480	5062-3798
22	0515-0896	5	4	HANDLE MACH SCREWS (NOT SHOWN)	28480	0515-0896
23	5062-4069	6	1	RACK MOUNT KIT FOR USE WITH HANDLES (INCLUDES ATTACHING HARDWARE)	28480	5062-4069
24	1460-1345	5	2	WIRE FOOT STAND	28480	1460-1345
				TOUCH-UP PAINT		
	6010-1146	6		DOVE GRAY PAINT FOR USE ON FRAME AROUND FRONT PANEL AND PAINTED PORTION OF HANDLES	28480	6010-1146
	6010-1147	7		FRENCH GRAY PAINT FOR USE ON SIDE, TOP, AND BOTTOM COVERS	28480	6010-1147
	6010-1148	8		PARCHMENT GRAY PAINT FOR USE ON RACK MOUNT FLANGES, RACK SUPPORT FLANGES, AND FRONT PANELS	28480	6010-1148

Figure 7-2A (2 of 2). Cabinet Parts

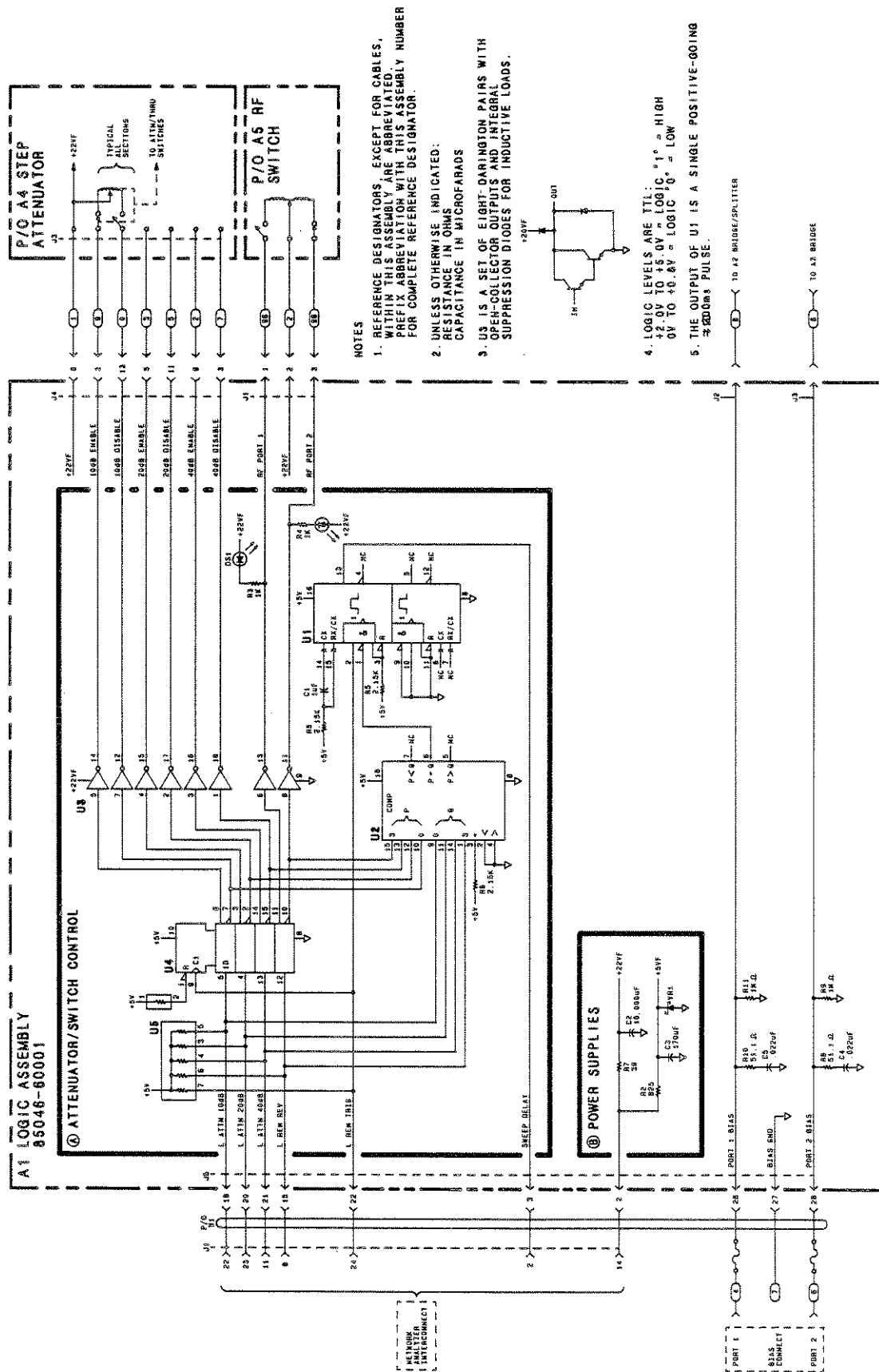
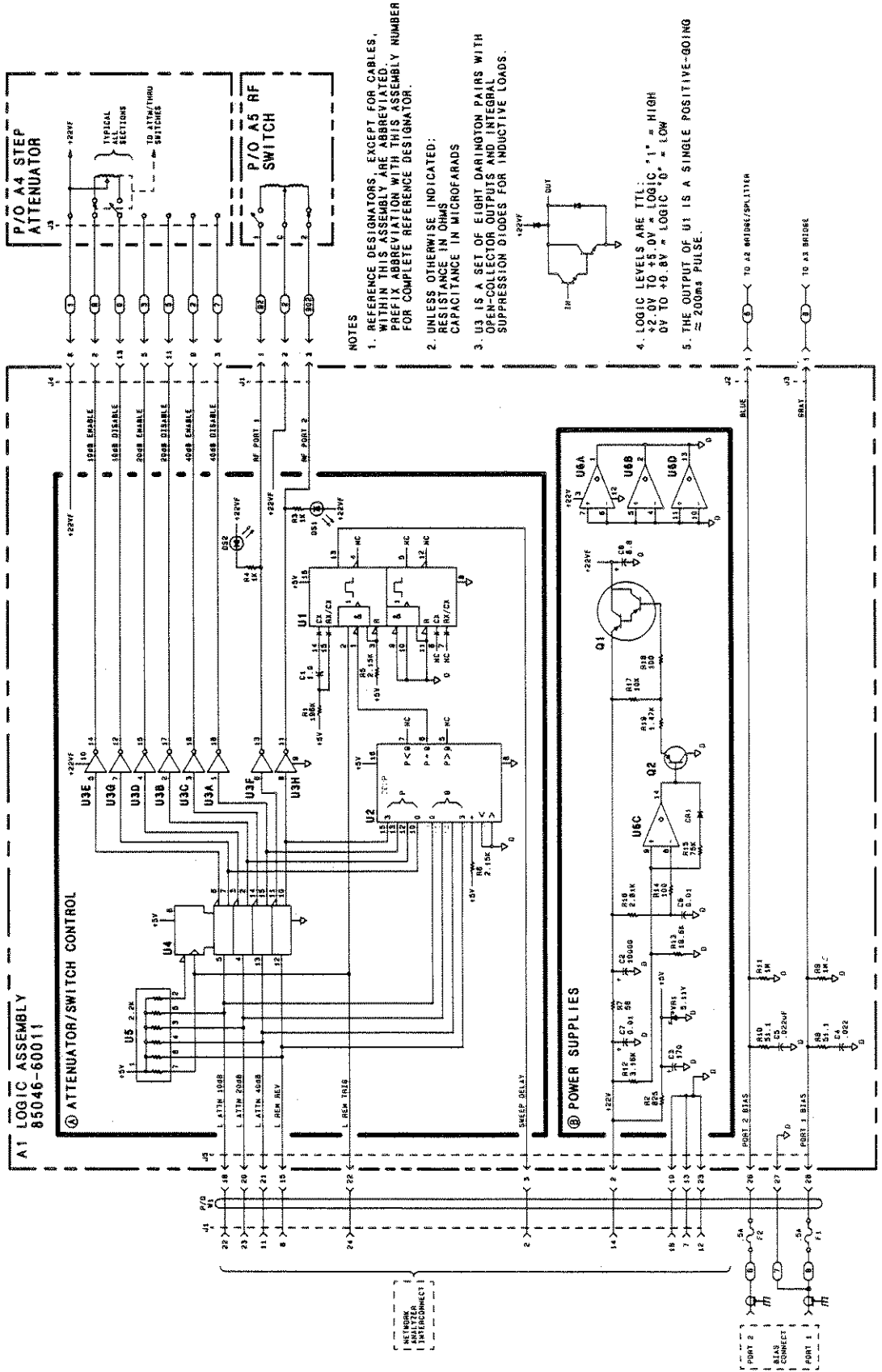

Figure 7-3. Front Panel and Logic Board Schematic Diagram



NOTES

1. REFERENCE DESIGNATORS, EXCEPT FOR CABLES, WITHIN THIS ASSEMBLY ARE ABBREVIATED. PREFIX ABBREVIATION WITH THIS ASSEMBLY NUMBER FOR COMPLETE REFERENCE DESIGNATOR.
2. UNLESS OTHERWISE INDICATED: RESISTANCE IN OHMS CAPACITANCE IN MICROFARADS
3. U3 IS A SET OF EIGHT DARLINGTON PAIRS WITH SPECIFIC INPUT AND OUTPUT LEVELS. SUPPRESSION DIODES FOR INDUCTIVE LOADS.
4. LOGIC LEVELS ARE TTL: +2.0V TO +5.0V = LOGIC "1" = HIGH 0V TO +0.8V = LOGIC "0" = LOW
5. THE OUTPUT OF U1 IS A SINGLE POSITIVE-GOING $\approx 200\text{ms}$ PULSE.

Figure 7-4. Front Panel and Logic Board Schematic Diagram

INTRODUCTION

This section provides instructions for troubleshooting and repairing the HP 85046A and 85046B S-parameter test sets. It includes simplified diagrams and schematic diagrams of the assemblies.

TROUBLESHOOTING

The intent of this section is to enable technicians to isolate problems to the assembly level, identify the defective assembly and order the replacement part. The schematic diagrams and circuit descriptions may be used to aid in troubleshooting to the component level. Recommended test equipment is listed in Table 1-2.

SERVICING THE DIRECTIONAL BRIDGE

The directional bridge assembly and the power splitter/directional bridge assembly are not field-repairable but they are replaceable on an exchange basis at a considerable cost saving. See "Exchange Assemblies Available" in Section 6 for additional information.

OVERALL TROUBLESHOOTING PROCEDURE

Check for proper voltages on the test set logic board assembly (the only circuit board in the instrument). Refer to Figure 6-1 as required. Check for the following conditions:

- +22 ± 5% Vdc at U3 pin 10
- +5 ± 5% Vdc at U1 pin 16

The test set receives +22 Vdc from the analyzer via the interconnect cable. Thus proper voltages at pins 10 and 16 indicate that the interconnect cable is properly connected and functioning, the test set rear panel/logic assembly ribbon cable is sound, and the +5V post-regulator circuitry is good.

RF TROUBLESHOOTING PROCEDURE

To troubleshoot RF path failures, use a power meter to check the RF power levels indicated on Figure 8-3. Connect the analyzer to the HP 85046A/B with the interconnect cable. Use the network analyzer to apply an RF signal of 1.5 GHz CW at 0 dBm to the RF IN port of the test set.

Perform the directivity performance test in Section 4 of this manual to check the directivity of both bridges. If the directivity is less than specified in Table 1-1, check the cables and connectors for damage and loose connections.

On the HP 85046A check the connector collets of ports 1 and 2 for possible damage. If replacement is indicated, replace them with new 6-slot collets. The replacement procedure, parts and equipment are included in the Microwave Connector Care manual (HP part number 08510-90064). Repeat the directivity check. Replace the directional bridge if the directivity is still less than that specified in Table 1-1.

NOTE: The internal SMA connectors have a low torque specification: 9 to 11 in-lb (1.0 to 1.2 Nm). Damage to the assembly or connector may result if this specification is exceeded.

Disconnect the RF cables one at a time and check for power levels as indicated by Figure 8-3.

Check the signal level at the outputs of the coaxial switch (A5). Press **[MEAS] [REFL: FWD S11 (A/R)]** on the analyzer and check the signal level. Then press **[REFL: REV S22 (B/R)]** and check again.

Measure the signal level into and out of the attenuator. Connect the power meter to the output connector of the attenuator. Use the analyzer to apply an RF signal of 1.5 GHz CW at +6 dBm to the RF IN port of the test set. To step the attenuator, press **[MENU] [POWER] [ATTENUATOR PORT 1]**. The power meter should read about 0 dBm. Step the attenuator down to 70 dB in 10 dB increments. The power meter reading should decrease 10 dBm with each step.

LOGIC CONTROL ASSEMBLY TROUBLESHOOTING

The step attenuator and the RF switch are controlled by signals from the analyzer. Within the test set the control signals are decoded by logic circuits which then activate drivers to perform the desired command. These logic and driver circuits reside on the logic board assembly, A1. Additionally, the logic control assembly includes components to filter the bias supplies of the bridges.

Refer to Figure 8-1 and Figure 8-2 to see which conductors in the interconnect cable carry which signals.

The L ATTN 10 dB, L ATTN 20 dB and L ATTN 40 dB lines drive the logic control of U4. U4 selects the appropriate drivers of U3 to activate the 10, 20 and 40 dB steps of the 70 dB step attenuator. U4 and U3 also activate the RF switch.

The SWEEP DELAY line is used to delay the sweep of the analyzer following a change of RF path or attenuation or both in the HP 85046A/B. This delay allows sufficient time for the mechanical parts of the test set to settle after a change. Figure 8-1 shows the sweep delay pulse.

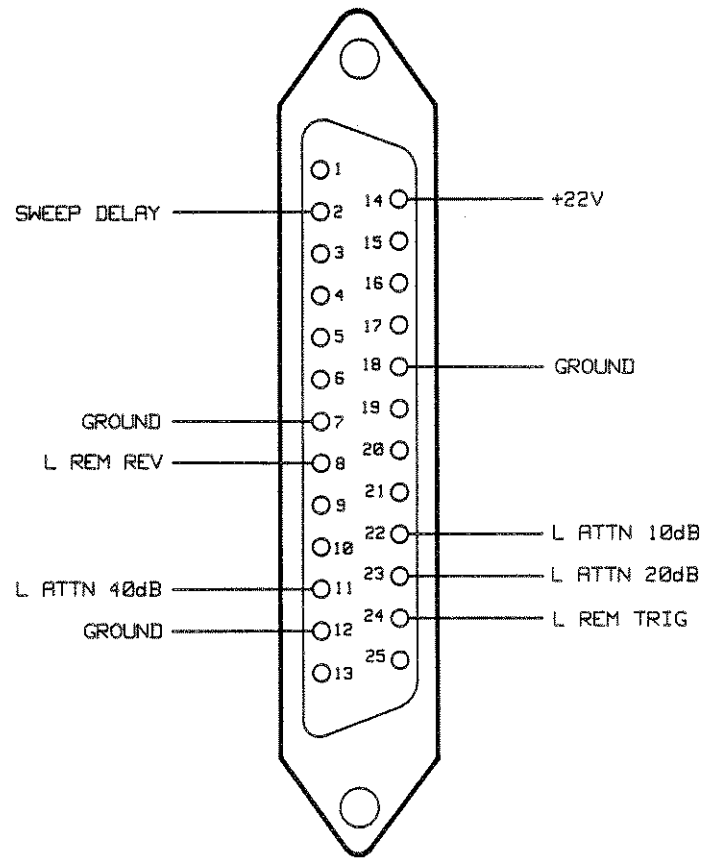

Instrument pulse with change in mechanical transfer switch or attenuator setting.



Instrument pulse with change in solid-state transfer switch setting.



Instrument pulse with change in solid-state transfer switch and attenuator setting.

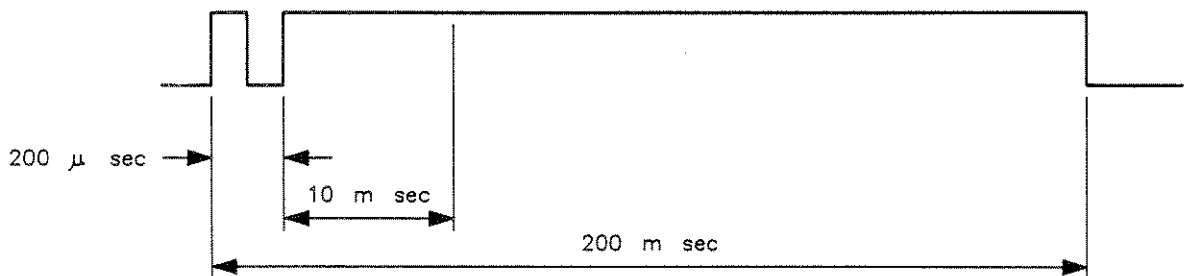
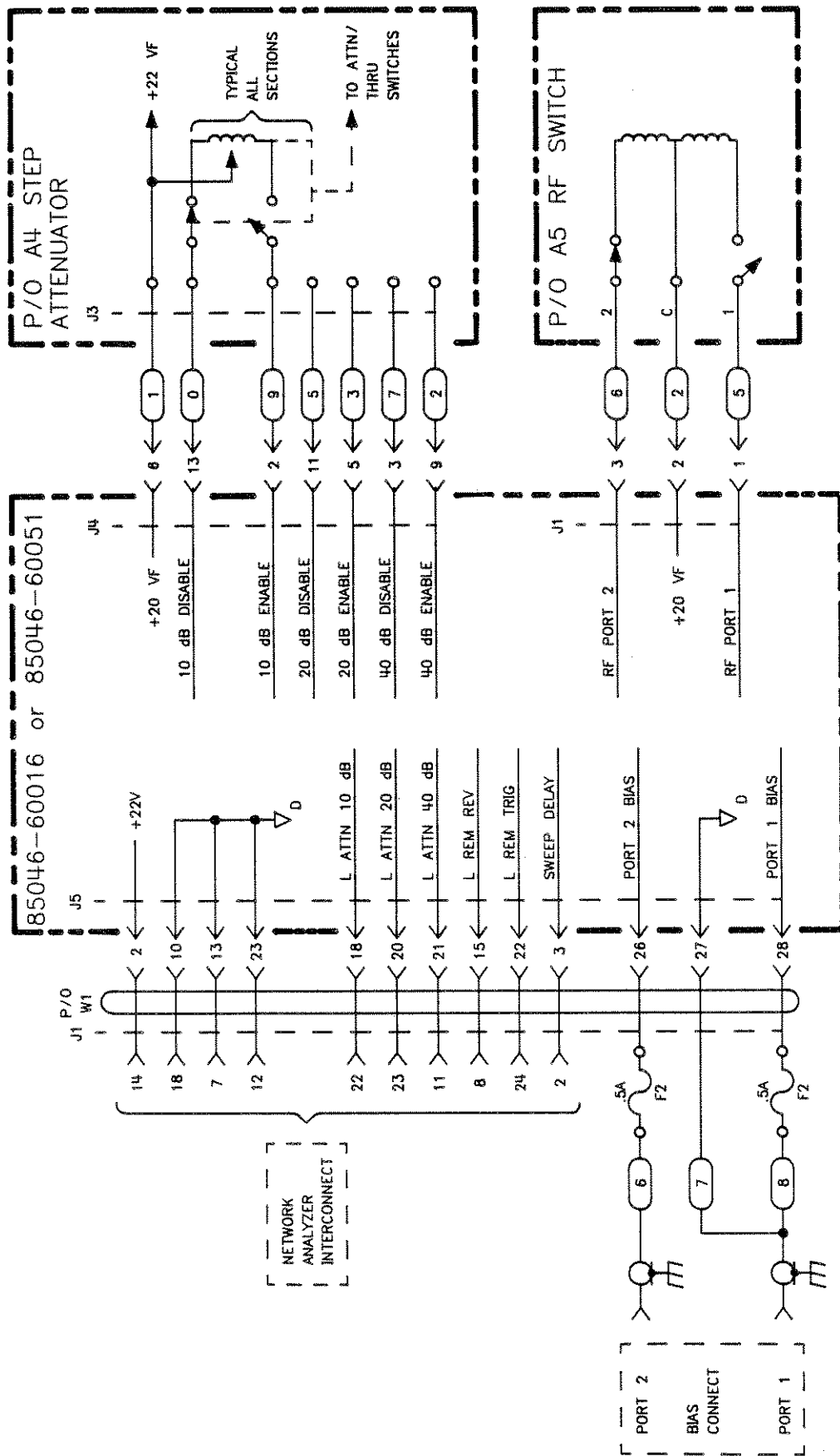

Figure 8-1. Test Set Interconnect Signal Lines and Sweep Delay Pulse



NOTES

1. REFERENCE DESIGNATORS, EXCEPT FOR CABLES, WITHIN THIS ASSEMBLY ARE ABBREVIATED. PREFIX ABBREVIATION WITH THIS ASSEMBLY NUMBER FOR COMPLETE REFERENCE DESIGNATOR.
2. UNLESS OTHERWISE INDICATED:
RESISTANCE IN OHMS
CAPACITANCE IN MICROFARADS
3. LOGIC LEVELS ARE TTL:
+2.0V TO +5.0V = LOGIC "1" = HIGH
0V TO +0.8V = LOGIC "0" = LOW

4. U3 IS A SET OF EIGHT DARLINGTON PAIRS WITH OPEN-COLLECTOR OUTPUTS AND INTEGRAL SUPPRESSION DIODES FOR INDUCTIVE LOADS.

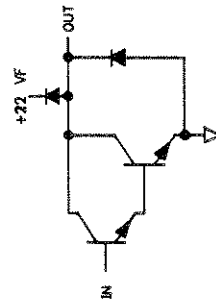

Figure 8-2. Front Panel and Logic Board Schematic Diagram

NOTES:

1. REFERENCE DESIGNATIONS, EXCEPT FOR CABLES, WITHIN THIS ASSEMBLY ARE ABBREVIATED. PREFIX ABBREVIATION WITH ASSEMBLY NUMBER FOR COMPLETE REFERENCE DESIGNATION.
2. UNLESS OTHERWISE INDICATED: RESISTANCE IS IN OHMS (Ω) CAPACITANCE IS IN MICROFARAOS (μF)
3. A5 TRANSFER SWITCH IN S_{11} / S_{21} POSITION.
4. COIL PORTION OF A4 AND A5 SHOWN ON A1 SWITCH LOGIC SCHEMATIC.
5. SIGNAL LEVELS ARE TYPICAL WITH NO DEVICE UNDER TEST CONNECTED BETWEEN PORTS 1 AND 2.
6. ABOUT 2dB LOWER FOR OPTION 001.

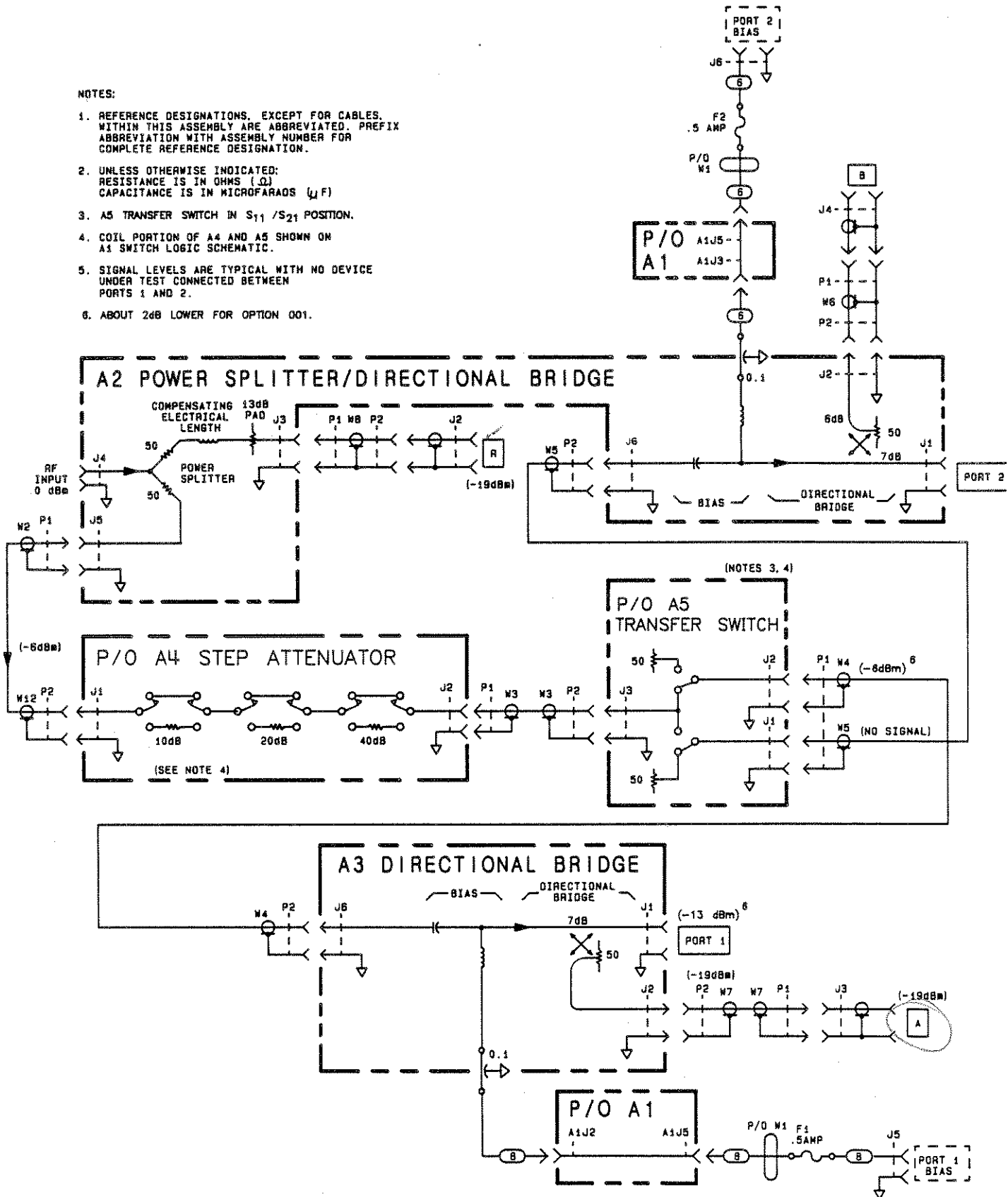

Figure 8-3. Schematic Diagram

