User's Guide

HP 8711A/11B/12B/13B/14B
Option H20/K20
Fault Location Software

HP part number: 08711-90121
Printed in USA March, 1995

Notice. The information contained in this document is subject to change without notice. Hewlett-Packard makes no warranty of any kind with regard to this material, including but not limited to, the implied warranties of merchantability and fitness for a particular purpose. Hewlett-Packard shall not be liable for errors contained herein or for incidental or consequential damages in connection with the furnishing, performance, or use of this material.

©Copyright Hewlett-Packard Company 1994, 1995
All Rights Reserved. Reproduction, adaptation, or translation without prior written permission is prohibited, except as allowed under the copyright laws.
1400 Fountaingrove Parkway, Santa Rosa, CA 95403-1799, USA

Hewlett-Packard Software Product License Agreement and Limited Warranty

Important

Please carefully read the License Agreement (located in Chapter 5) before opening the media envelope or operating the equipment. Rights in the software are offered only on the condition that the Customer agrees to all terms and conditions of the License Agreement. Opening the media envelope or operating the equipment indicates your acceptance of these terms and conditions. If you do not agree to the License Agreement, you may return the unopened package for a full refund.

Introduction

The Option H20/K20 Fault Location Software is a set of programs designed to run on any of the following network analyzers:

HP 8711A

HP 8711B

HP 8712B

HP 8713B

HP 8714B

If you ordered option H20, you received a network analyzer and the fault location software. If you ordered option K20, you already own one of the above-mentioned analyzers and you received a kit consisting of the fault location software and two firmware disks (HP 8711A only – see note below). To run the fault location software, your analyzer must have IBASIC (Option 1C2) installed.

NOTE

If you have ordered HP 8711A option K20 (you already had an HP 8711A and you just ordered the fault location software) you will need to load the new firmware that was provided with your shipment before running the software. Refer to Appendix A to perform firmware loading.

The fault location software can help you test and troubleshoot 50 ohm or 75 ohm transmission lines. The software uses the analyzer to perform swept frequency measurements of return loss over the frequency ranges of 300 kHz to 1300 MHz (for HP 8711A/11B/13B) and 300 kHz to 3000 MHz (for HP 8712B/14B). Digital signal processing is performed on the result to convert frequency domain measurements to the distance domain. In the default mode, a split screen display is used, showing both return loss (in dB) versus frequency and return loss (in dB) versus distance. The display units can also be expressed in SWR or reflection coefficient.

The following illustration depicts a typical measurement display. The upper display shows the measurement in the frequency domain. The bottom display shows the response in the distance domain. Six markers identify mismatches along the cable.

- Marker 1 identifies the cable connector.
- Markers 2, 3, 4, and 5 identify barrel connectors separated by 4 feet.
- Marker 6 identifies a 50 ohm termination.

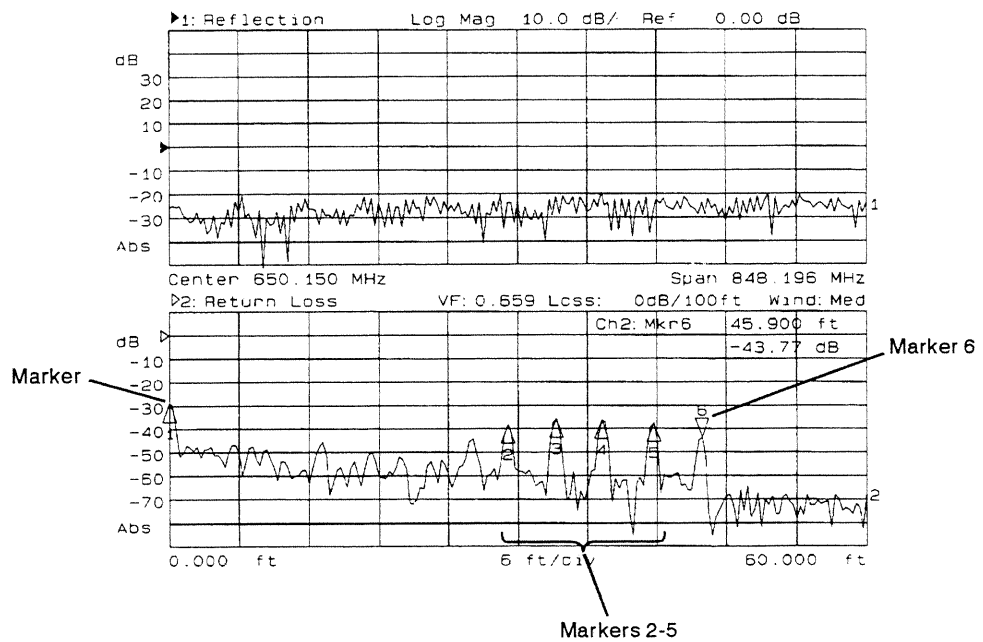

md61ab_c

Documentation Outline

This guide contains five chapters:

Getting Started	Contains information on how to run the software and how to use the program's main menu.
Making Measurements	Contains basic fault location measurement theory, how to make and interpret measurements, and example measurements.
Key Reference	Contains general key functions of front-panel and softkeys. This reference section is arranged alphabetically by front-panel key (hardkey).
Performance Summary and Characteristics	Contains a summary of software performance and distance range and resolution data.
License Agreement and Limited Warranty	Contains the Hewlett-Packard software license agreement and limited warranty information. Read this chapter before opening the media envelope.
Appendixes	Contain information on how to load firmware (for HP 8711A Option K20), a table with typical values of cable loss and velocity factor, in-depth measurement theory, and external programming information.

Key Conventions. This manual uses the following conventions:

Front-Panel Key	This represents a key physically located on the instrument (a "hardkey").
Softkey	This indicates a "softkey," a key whose label is determined by the instrument's firmware, and is displayed on the right side of the instrument's screen next to the eight unlabeled keys.

Contents

1. Getting Started	
Running the Software	1-3
To Run the Software Using the AUTOST Program	1-4
To Load the FAULT Program From the Front Panel	1-5
To Run the Program After It Has Been Loaded	1-5
If an Error Message Appears	1-6
The Program Main Menu	1-7
Default Setup	1-8
Guided Setup	1-9
Setup Diagram	1-11
PAUSE	1-11
Exiting the Program	1-12
2. Making Measurements	
Basic Fault Location Measurement Theory	2-3
How to Make and Interpret Measurements	2-4
Enter the Measurement Parameters	2-5
Calibrate the Instrument	2-6
Connect the Equipment	2-7
Interpret the Measurement	2-8
Example Measurements	2-11
Example 1: Identify Mismatches Expressed as Return Loss	2-12
Example 2: Identify Mismatches as the Magnitude of Reflection	2-14
Example 3: Identify Mismatches at Greater Distances	2-16
3. Key Reference	
Menumaps	3-3
MEAS	3-4
SOURCE	3-5
CONFIGURE	3-6
SYSTEM	3-7
Alphabetical Reference	3-8
AVG	3-9

CAL	3-10
CHAN 1	3-13
CHAN 2	3-14
DISPLAY	3-15
FORMAT	3-16
FREQ	3-17
HARD COPY	3-18
MARKER	3-19
MENU	3-21
POWER	3-22
SAVE RECALL	3-23
SCALE	3-24
SWEEP	3-26
SYSTEM OPTIONS	3-27

4. Performance Summary and Characteristics

General Performance Characteristics	4-3
Distance Range and Resolution	4-4
Range	4-4
Resolution	4-4
Typical Distance Data in Feet	4-5
Distance Data in Meters	4-8

5. License Agreement and Limited Warranty

License Agreement	5-3
Use	5-3
Copies and Adaptations	5-3
Ownership	5-4
Transfer of Rights in Software	5-4
Sublicensing and Distribution	5-5
Termination	5-5
Updates and Upgrades	5-5
Export	5-5
Limited Warranty	5-6
Software	5-6
Media	5-6
Notice of Warranty Claims	5-7
Limitation of Warranty	5-7
Exclusive Remedies	5-7
Warranty Service	5-7

A. HP 8711A Option K20: Installing the Firmware	
Step 1. Format the Blank Disk	A-3
Step 2. Store the Analyzer's Correction Constants To the Disk	A-4
Step 3. Determine the Correct Firmware for Your Analyzer	A-5
Step 4. Load the New Firmware	A-6
Step 5. Restore the Correction Constants	A-7
B. Cable Loss and Velocity Factor Table	
C. Measurement Theory	
How the Analyzer Converts Frequency Data to Distance	
Data	C-3
Start/Stop Distance and Frequency Span Explanation . .	C-4
D. External Programming	
Index	

Figures

2-1. Fault Response to an RF Signal	2-3
2-2. Calibrate the Instrument	2-6
2-3. Basic Fault Location Measurement Setup	2-7
2-5. Channel 2 Display	2-9
2-8. Example 1: Identify Mismatches Expressed as Return Loss	2-13
2-9. Example 2: Identify Mismatches as the Magnitude of Reflection Coefficient	2-15
2-11. Example 3: Identify Mismatches at Greater Distance	2-17
2-12. Example 3: Zoom In On Suspected Mismatches	2-18

Tables

1-1. Default Setup Parameters	1-8
2-1. Guided Setup Parameters Access Keys	2-5
4-1. Fault Location Distance Range or Maximum Distance (in feet) Versus Resolution at 201 Points*	4-5
4-2. Fault Location Distance Range or Maximum Distance (in meters) Versus Resolution at 201 Points*	4-8
B-1. Cable Loss and Velocity Factor Table *	B-2
B-1. Cable Loss and Velocity Factor Table (continued)	B-3

Getting Started

Getting Started

This chapter will step you through running the fault location software and describe the main menu options available to you after the software is running. Your analyzer must have Option 1C2, IBASIC, installed in order to run the fault location software. To verify that option 1C2 is installed on your analyzer, press **SYSTEM OPTIONS** **Service Instrument Info** on the analyzer. If the IBASIC option is installed you will see the following message on the display:

IBASIC Option (1C2): Installed

If IBASIC has not been installed on your analyzer, you can order an IBASIC upgrade kit. See the table below for the model/part number to order for your particular analyzer. Contact the nearest Hewlett-Packard sales or service office for information and assistance.

Your Analyzer	IBASIC Kit Model Number	IBASIC Kit Part Number
HP 8711A	HP 86224A	08711-60061
HP 8711B	HP 86224B	08711-60068
HP 8712B	HP 86224B	08711-60068
HP 8713B	HP 86224B	08711-60068
HP 8714B	HP 86224B	08711-60068

NOTE

If you have ordered HP 8711A option K20 (you already had an HP 8711A and you just ordered the fault location software) you will need to load the new firmware that was provided with your shipment before running the software. Refer to Appendix A to perform firmware loading.

Running the Software

To run the software you will need the software disk (HP part number 08711-10013). The software disk contains the following three programs:

FAULT	Measures return loss, SWR, or the magnitude of the reflection coefficient simultaneously versus distance and frequency.
AUTOST	Automatically loads at power up with the software disk installed into the disk drive or if located on the analyzer's internal non-volatile RAM disk.
FAULTEXT	This program runs on an external RMB controller or PC. The program FAULT is downloaded to the analyzer and is run by FAULTEXT. Within FAULTEXT, standard SCPI commands are used to communicate parameter changes to the analyzer running the FAULT application. This program demonstrates automated measurement changes.

NOTE

The "FAULT" and "AUTOST" programs are identical. They have been renamed for convenience. It is always a good practice to make a backup copy of your software and keep it in a safe place. Then, in the event that the original is damaged or lost, you will still have a working copy of the software.

To Run the Software Using the AUTOST Program

When you turn on the analyzer, it first searches the internal non-volatile memory and then the 3.5" disk drive for a program named AUTOST, and then runs it.

The easiest way to run the application software is to just insert the fault location software disk into the analyzer's 3.5" disk drive and cycle the power on the analyzer. The program will automatically load and run. The analyzer will immediately be ready to make fault location measurements.

The program can also be automatically run if it has been copied to the analyzer's internal non-volatile memory. To do this, insert the fault location software disk into the analyzer's 3.5" disk drive and complete the following procedure:

1. Press **SAVE RECALL**, **Select Disk**, **Internal 3.5" Disk**.
2. Use the analyzer's front panel knob to select the AUTOST program.
3. Select **Prior Menu**, **File Utilities**, **Copy File**,
Copy to NonVol RAM **Enter**.

Once the AUTOST program has been copied to the analyzer's internal non-volatile memory, it will automatically start the fault location program every time the power is turned on.

To Load the FAULT Program From the Front Panel

If you do not wish to cycle the power on the analyzer to load the program, you can load and run the fault location software by performing the following steps:

1. Insert the fault location software disk into the analyzer's disk drive.
2. Press **SAVE RECALL**, **Select Disk**, **Internal Disk**.
3. Use the analyzer's front panel knob to select the FAULT program.
4. Press **Prior Menu**, **Programs**, **Recall Program**, **Run**.

To Run the Program After It Has Been Loaded

After the fault location software has been loaded into the analyzer via either of the above procedures, it can be run from the front panel by pressing **SYSTEM OPTIONS**, **IBASIC**, **Run** or **Continue**. Pressing **Run** will rerun the program from scratch and reinitiate the analyzer and its settings. If you have paused the program with the **PAUSE** softkey, pressing **Continue** will resume the program from where it was paused.

CAUTION

Changes made to the instrument state while the program is paused may result in unspecified behavior. Press **Run** to restart the program and reset the instrument to default fault-location application parameters.

To return the instrument to normal network analyzer operation, press **PRESET**.

If an Error Message Appears

If an error message appears when you attempt to run the software, the most likely cause is improper firmware.

If you have ordered HP 8711A Option K20 (software and firmware), be sure that the proper firmware has been installed. Refer to Appendix A.

The Program Main Menu

After the software has initialized and the program is running, there are four softkey options available to you:

- Default Setup
- Guided Setup
- Setup Diagram
- PAUSE

To access this menu at any time when the fault location software is running, press **BEGIN**.

Default Setup

Pressing this softkey returns the instrument settings to the fault location program's initial or default state.

When the fault location program is initially run, the analyzer is automatically set to the default state. The default state for the program measures return loss versus frequency on Channel 1 and return loss versus distance on Channel 2.

Other default settings are:

Table 1-1. Default Setup Parameters

Parameter	Default Value
Center frequency	650.150 MHz
Stop distance	100 feet
Start distance	0 feet
Velocity factor	0.659
Cable loss	0 dB/100 feet

Guided Setup

When the **Guided Setup** key is pressed, the instrument will prompt you for the basic information required for your measurement, ask if you want to calibrate or not, and show the basic equipment setup diagram. You will be asked to enter the following parameters:

- Center frequency
- Stop distance
- Start distance
- Velocity factor
- Cable loss

You must terminate each entry with either the **ENTER** hardkey or the **Enter** softkey. If you wish to retain the default value for any particular parameter (see Table 1-1) just press **ENTER** or **Enter** instead of inputting a value.

Next, you will be asked whether you want to calibrate the instrument or not. See “Calibrate the Instrument” in Chapter 2 for more information on calibration. To perform an instrument calibration, you must have type-N open, short and load standards, such as those found in Hewlett-Packard calibration kits model numbers HP 85032E (50 ohm) and HP 85036E (75 ohm). If you wish to calibrate, press **1** **ENTER** and follow the prompts. Otherwise, just press **ENTER** and the instrument will then show the basic equipment setup diagram on the display.

After your equipment is set up, press **ENTER** or **Enter** to view the measurement screen. At this time you can use markers or limit lines to interpret your measurement. See “Interpret the Measurement” in Chapter 2.

NOTE

As changes are made to center frequency, stop distance, start distance and velocity factor, a pop-up message will temporarily appear with the following message:

Changing Frequency Settings...
WARNING: Cable Cal May Be Invalid.
Please confirm Cable Loss and
Velocity Factor.

Frequency span settings are dependent on center frequency, stop and start distance, and velocity factor. Refer to Appendix B for a table of typical loss and velocity factors or refer to information provided by the manufacturer of your cable. Refer to Appendix C for an explanation of the relationship between frequency span and distance range.

Setup Diagram

When this softkey is pressed, the instrument will show the basic equipment setup diagram on the display. Press **ENTER** or **Enter** to return to the normal display.

PAUSE

The program can be paused at any time by pressing the **PAUSE** softkey. This softkey is available at all times when running the fault location software. To resume the program, press **SYSTEM OPTIONS**, **IBASIC**, **Continue**.

CAUTION

Changes made to the instrument state while the program is paused may result in unspecified behavior. Press **Run** to restart the program and reset the instrument to default fault location application parameters.

Exiting the Program

The program can be exited, and the analyzer returned to normal operation by pressing the **PRESET** key.

Making Measurements

Making Measurements

This chapter contains the following information:

- basic fault location measurement theory
- how to make and interpret measurements
- example measurements

Basic Fault Location Measurement Theory

The fault location software was designed to quickly and easily locate faults, or discontinuities, in either 50 ohm or 75 ohm transmission lines. Refer to Figure 2-1 for the following discussion.

The network analyzer has an RF signal source that produces an incident signal that is used as a stimulus to locate and measure discontinuities in your transmission line or cable. Each fault or discontinuity responds by reflecting a portion of the incident signal and transmitting the remaining signal.

The instrument measures the frequency response of the cable and then transforms the frequency data to distance data; for more measurement theory, refer to Appendix C.

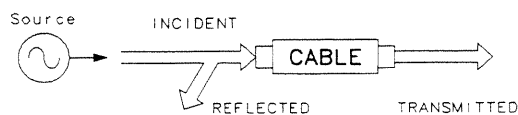

md61a

Figure 2-1. Fault Response to an RF Signal

The measurement results can be expressed in one of three ways:

Return Loss (RL)	The number of dB that the reflected signal is below the incident signal. Its relationship to the reflection coefficient (ρ) is described by the following formula: $RL = -20 \log \rho$.
Reflection Coefficient (ρ)	The ratio of the reflected voltage wave to the incident voltage wave.
Standing Wave Ratio (SWR)	Any two waves traveling in opposite directions (the incident and reflected for example) cause a "standing wave" to be formed on the transmission line. SWR is defined as the maximum voltage over the minimum voltage of the standing wave. SWR can also be mathematically derived from the reflection coefficient (ρ) with the following formula: $SWR = \frac{1 + \rho}{1 - \rho}$

How to Make and Interpret Measurements

After the program is running (see Chapter 1), a typical measurement consists of the following steps:

1. Enter the measurement parameters.
2. Calibrate the instrument.
3. Connect the equipment.
4. Interpret the measurement.

The next few pages explain how to perform each of these steps.

Enter the Measurement Parameters

Once the program is running and the equipment is set up, use the **Guided Setup** function to enter parameters for your measurement. The guided setup function will prompt you to enter the following parameters:

- Center frequency
- Stop distance
- Start distance
- Velocity factor
- Cable loss

You may also use the instrument hardkeys and softkeys to change instrument settings.

Table 2-1 shows which keys to press to enter the parameters that are asked for in the guided setup. Other parameters may be entered using the instrument keys and are discussed in Chapter 3, “Key Reference.”

Table 2-1. Guided Setup Parameters Access Keys

Parameter	Access Keys
Center frequency	FREQ , Center Freq
Stop distance	MENU (or SCALE), Stop Distance
Start distance	MENU (or SCALE), Start Distance
Velocity factor	CAL , Velocity Factor
Cable loss	CAL , Cable Loss

NOTE

Inspect or measure your cable for velocity factor and cable loss per 100 feet specifications. If your cable is not marked with these parameters, you may refer to Table B-1 in Appendix B for some typical numbers. The numbers in Table B-1 are typical only.

Calibrate the Instrument

When practical, a calibration should be done at the RF OUT port using open, short, and load calibration standards. If you are using the guided setup function, the instrument will prompt you to perform a calibration. This requires type-N calibration standards. This calibration will correct the instrument and optimize your accuracy. If calibration standards are not available, the default instrument calibration can be used.

To Use Calibration Standards to Calibrate the

Instrument To calibrate the instrument using calibration standards, follow the prompts in the guided setup function, or perform the following steps:

1. Press **CAL**, **Calibrate Instrument**.
2. Follow the prompts on the analyzer's screen to connect the open, short and load to the instrument's RF OUT port. (See Figure 2-2.)

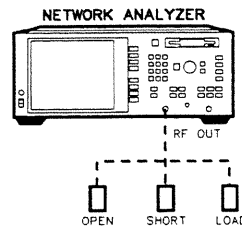

ad625o

Figure 2-2. Calibrate the Instrument

To Use the Default Calibration

To use the instrument default calibration, press **CAL**, **Reset Cal to Default**.

Connect the Equipment

The basic equipment setup for fault location measurements is illustrated in Figure 2-3. This diagram is automatically displayed when using the guided setup function, or it can be displayed at any time by pressing **BEGIN Setup Diagram**.

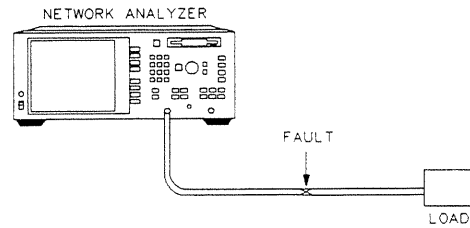

md62a

Figure 2-3. Basic Fault Location Measurement Setup

Interpret the Measurement

Once the measurement parameters have been set up, you can use markers to find the peak responses (which indicate faults or discontinuities), or you can place a test limit line on the screen that will indicate whether or not your cable meets a particular specification.

In the following example, two four-foot cables are connected in series to the RF OUT port of the analyzer and are terminated with a 50 ohm load. See Figure 2-4.

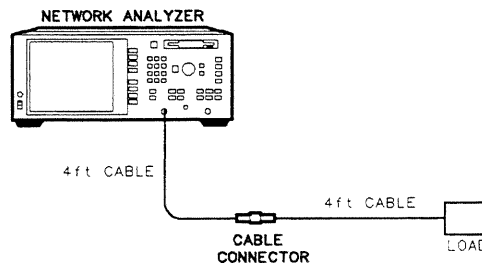

md63c

Figure 2.4.

Using Markers to Find Peak Responses Press **MARKER**.

Marker number 1 will automatically be placed on the peak with the highest response. Refer to Figure 2-5. Notice that the display indicates that the response marked by marker number 1 is 4.000 feet from the RF OUT port, and has a return loss of -27.45 dB. Knowing that we connected two four-foot cables together for this example, it can be determined that this discontinuity is created by the connection between the two cables.

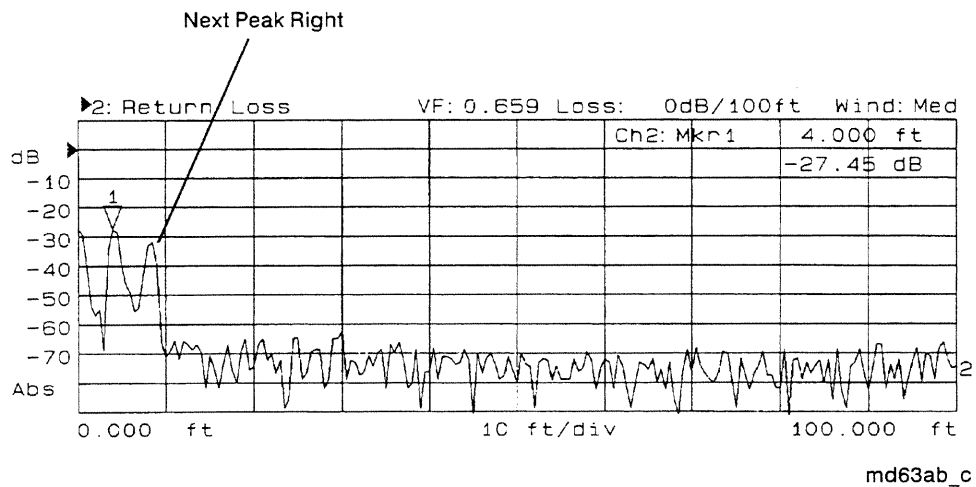

Figure 2-5. Channel 2 Display

Press **Next Peak Right**. When this function is used, the active marker moves to the next highest peak to the right. If you were performing this example, you would notice that marker number 1 has now moved over to the peak indicated as “Next Peak Right” in Figure 2-5. You would also notice that the display would now indicate that the response marked by marker number 1 is 8.000 feet from the RF OUT port. Knowing that we connected two four-foot cables for this example, it can be determined that this response is created by the termination at the end of the two cables.

See **MARKER** in Chapter 3 for more information on using markers.

How to Make and Interpret Measurements

Using a Limit Line For Testing a Cable

In this example, we have a transmission line return loss specification of < -22 dB. To set the limit line to -22 dB, press **SYSTEM OPTIONS** **Limit Line** **-22** **ENTER**.

Refer to Figure 2-6. Since all responses in this example fall below the test limit line, the display indicates "PASS."

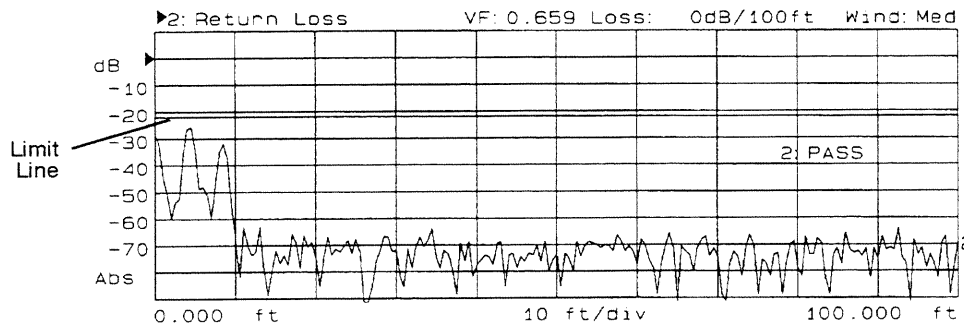

md64ab_c

Figure 2-6.

Press **Limit Line** **-28** **ENTER**.

In this example, setting the limit line to -28 dB return loss would cause the display to indicate "FAIL." This is due to the response at 4 feet exceeding the -28 dB limit. In a real test situation you could quickly and easily determine whether or not your cable meets your specification by correctly setting the limit line to your return loss specification and just looking for the "PASS" or "FAIL" indicator. With a failure you might want to activate a marker (or markers) to determine the magnitude and location of any out-of-specification responses.

Example Measurements

This section contains three measurement example displays with an explanation of the measurement results. These examples may be reproduced by using the test setup diagrams, procedures and explanations with each example.

NOTE

Some of the illustrations with the following examples were created by using the **HARD COPY** **Plot HPGL to Disk** function. (See **HARD COPY** in Chapter 3.) Whenever the markers are turned on, this marker table becomes part of the graphic that is plotted to the disk.

Example 1: Identify Mismatches Expressed as Return Loss

1. Set up the equipment as shown in Figure 2-7.

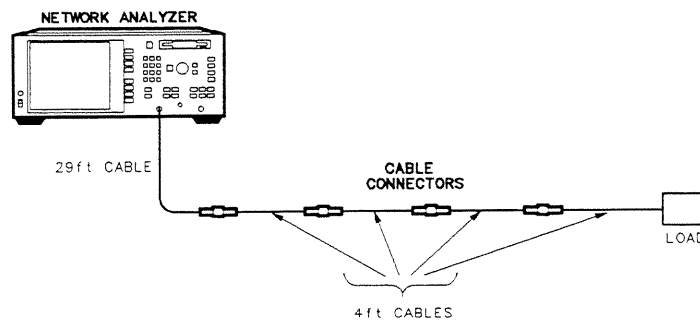

md64a

Figure 2-7.

2. Press **BEGIN** Default Setup .
3. Press **SCALE** Stop Distance **60** **ENTER**.
4. Press **MARKER** and then use the front panel knob and/or up and down arrow keys to place marker 1 all the way to the left side of the display as in Figure 2-8.
5. Press **2** to activate marker 2 and use the front panel knob, the up and down arrow keys, the **Next Peak Left** , or the **Next Peak Right** functions to place marker 2 on the next response as shown in Figure 2-8.
6. Repeat the previous step for markers 3 through 6.

In this example, the first marker displays the return loss at the cable connector. Markers 2, 3, 4, and 5 identify barrel connectors separated by 4 feet. Marker 6 identifies the 50 ohm termination.

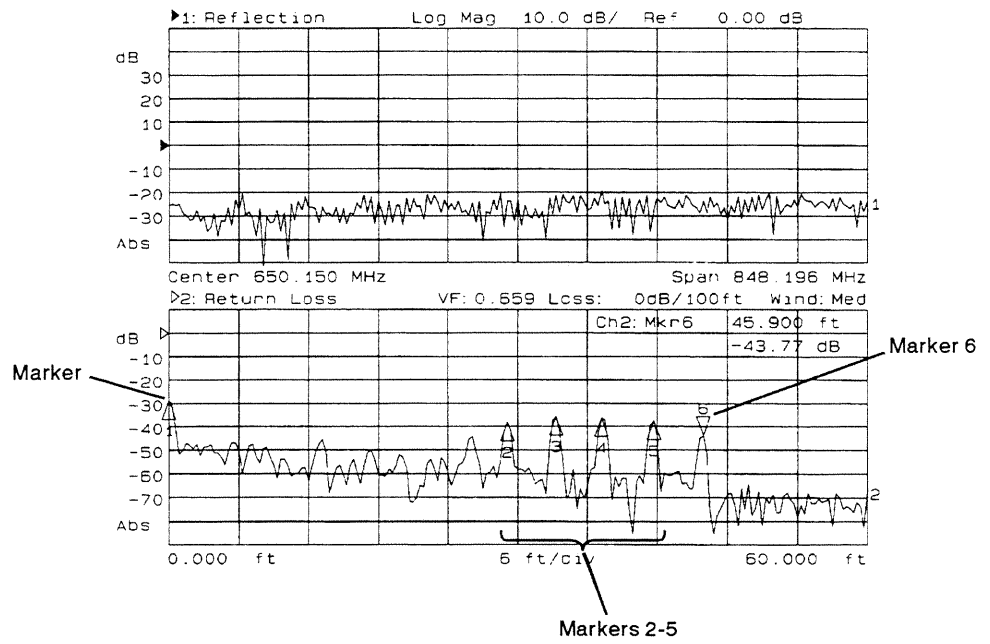

md61ab_c

Figure 2-8. Example 1: Identify Mismatches Expressed as Return Loss

Example 2: Identify Mismatches as the Magnitude of Reflection

Coefficient

For this example, use the same equipment setup and steps to place markers on responses as instructed in example 1.

Press the following keys:

CHAN 2 Refl. Coeff. Mag.

SCALE Autoscale.

This example is very similar to example 1 except that the responses are measured in terms of reflection coefficient rather than return loss. **Autoscale** is used to optimize the viewing of the data trace within the display area.

As in example 1, the response designated by marker 1 identifies the cable connector. Markers 2, 3, 4, and 5 identify barrel connectors separated by 4 feet. Marker 6 identifies the 50 ohm termination.

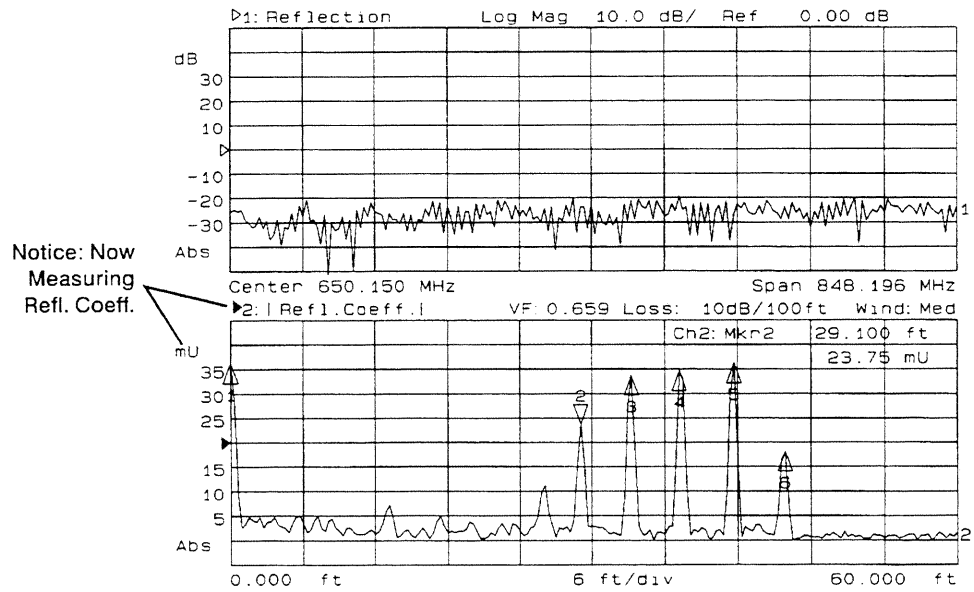

md62ab_c

Figure 2-9. Example 2: Identify Mismatches as the Magnitude of Reflection Coefficient

Example 3: Identify Mismatches at Greater Distances

In the previous two examples, we were dealing with relatively short lengths of cable (≈ 45 feet). In this example a longer length cable is used.

1. Set up the equipment as shown in Figure 2-10.

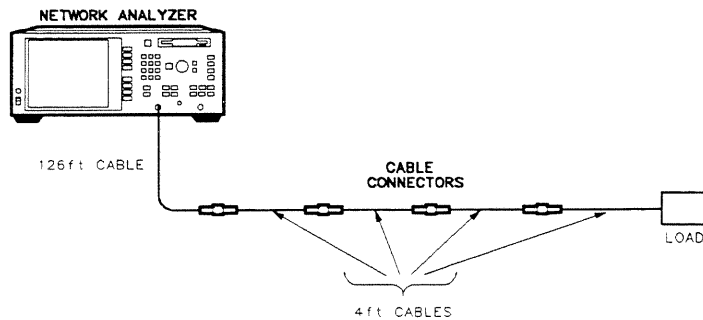

md65c

Figure 2-10.

2. Press **BEGIN** Default Setup .
3. Use **Guided Setup** to enter a stop distance of 200 feet, and a cable loss factor of 1.8 dB/100 feet.
4. Use markers to identify the responses. See example 1 for detail on how to place markers.

The display should now look similar to Figure 2-11.

5. At greater distance the resolution is decreased. In this example, marker 1 identifies the cable connector. Markers 2, 3, 4, and 5 identify barrel connectors. Marker 6 identifies a 50 ohm termination.

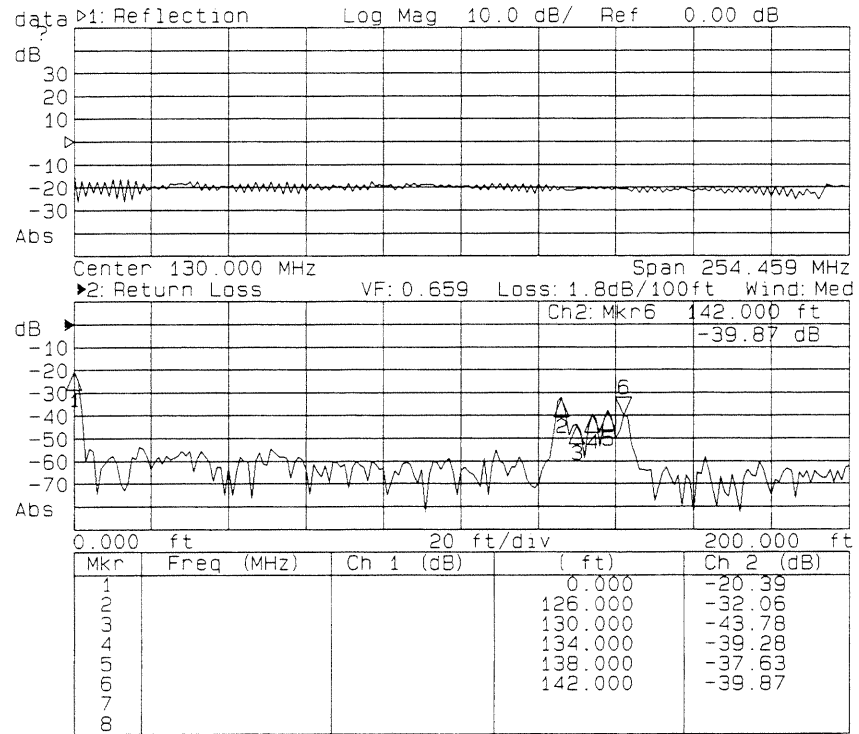

Figure 2-11. Example 3: Identify Mismatches at Greater Distance

Making Measurements

You can now change the **Stop Distance** and **Start Distance** (in the **SCALE** menu) to zoom in around the responses marked by markers 2 through 6. See Figure 2-12.

Use the **MARKER** menu to place markers 1 through 5 on the peak responses. Marker 1 is the first connector. Marker 5 identifies the 50 ohm termination.

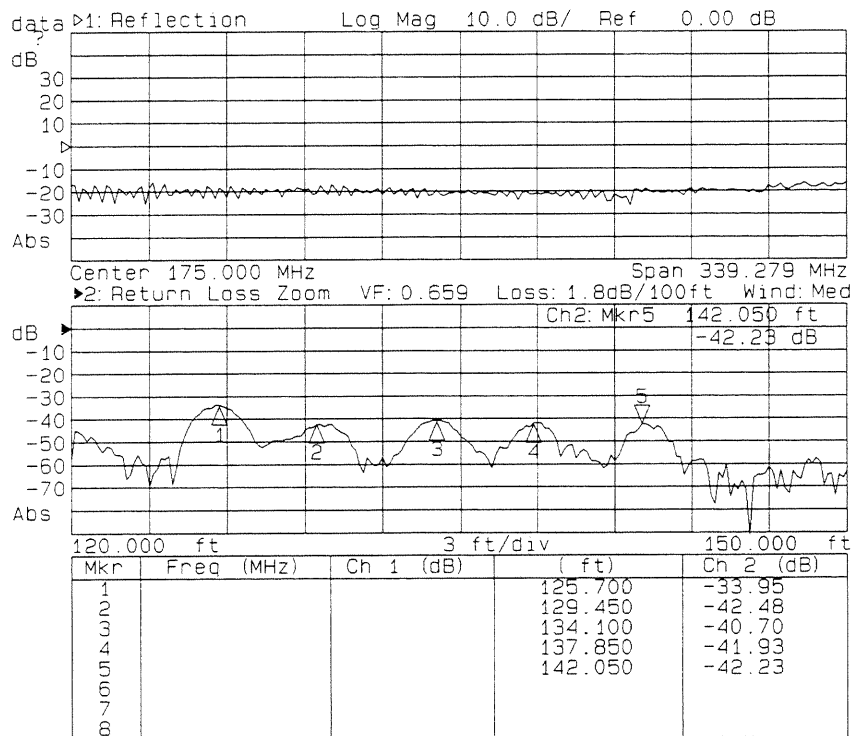

Figure 2-12. Example 3: Zoom In On Suspected Mismatches

NOTE

As you change the stop and start distance, a pop-up message will temporarily appear with the following message:

Changing Frequency Settings...
WARNING: Cable Cal May Be Invalid.
Please confirm Cable Loss and
Velocity Factor.

Frequency settings are dependent on center frequency, stop and start distance, and velocity factor. Refer to Appendix B for a table of typical loss and velocity factors or refer to information provided by the manufacturer of your cable. Refer to Appendix C for an explanation of the relationship between frequency span and distance range.

———— Key Reference

Key Reference

With the fault location software loaded and running in the analyzer, the hardkeys perform different functions than with normal analyzer operation.

The first part of this chapter contains menu maps showing the softkey functions available under each hardkey. This section is organized by front panel function group.

The second part of this chapter contains an alphabetical reference of each hardkey, along with the functions (softkeys) that are accessed by each key.

Menu maps

The main softkey functions under each hardkey are depicted on the next few pages. The menu maps in this section are organized by front panel function group.

Pressing a softkey in some cases performs a function, and in other cases may lead to another level of softkeys. Refer to the alphabetical hardkey reference following this section for information on softkey functions, and any lower level softkeys.

MEAS

CHAN 1	CHAN 2
Ch1:Return Loss	Ch2:Return Loss
Ch1: Refl. Coeff. Mag	Ch2: Refl. Coeff. Mag
Ch1: SWR	Ch2: SWR
PAUSE	PAUSE

SOURCE

FREQ	SWEEP	POWER	MENU
Center Freq	Continuous	Power Level	101 Points
	Hold		201 Points
	Single		401 Points
			Start Distance
			Stop Distance
PAUSE	PAUSE	PAUSE	PAUSE

Key Reference
Menumaps

CONFIGURE

SCALE	DISPLAY	CAL	MARKER	FORMAT	AVG
Autoscale	Full Screen	Reset Cal to Default	Active Mkr->Max	Feet	Average Restart
Scale/Div	Split Screen	Calibrate Instrument	Next Peak Right		Average OFF
Reference Level	Marker Screen	Velocity Factor	Next Peak Left	Meters	Average Factor
Reference Position		Cable Loss	Delta Mkr OFF/ON		
Start Distance	Graticule ON/OFF	Calibrate Cable	Active Mkr Off		
Stop Distance		Multi Peak Threshold	All Off		
		Multi Peak Corr OFF/ON	More Mkrs		
PAUSE	PAUSE	PAUSE	PAUSE	PAUSE	PAUSE

SYSTEM

SAVE RECALL	HARD COPY	SYSTEM OPTIONS	
Save Setup/Data	Plot to Default	Window	Minimum
Recall Setup/Data	Plot HPGL to Disk		Medium
		Limit Line	Maximum
Save ASCII Trace Data		Title and Clock On	
Delete Files		Title and Clock Off	
Format Disk		Change Title	Cancel
PAUSE	PAUSE	PAUSE	PAUSE

Alphabetical Reference

This section is organized alphabetically by hardkey.

AVG

Pressing this key displays the average menu.

Averaging reduces random noise by averaging the measurement data from sweep to sweep. In averaging mode, the network analyzer measures each frequency point once per sweep and averages the current and previous trace up to the averaging factor (or number) specified by the user. The instrument computes each data point based on an exponential average of consecutive sweeps weighted by a user-specified averaging factor.

Average Restart Restarts averaging of the frequency domain data after it has been turned on by using the **Average OFF/ON** softkey.

Average OFF/ON Toggles averaging on and off.

Average Factor Allows entry of new averaging factor. The default is 16 and the maximum is 64.

NOTE

Averaging is performed on the frequency domain data only. The distance domain data is not averaged.

CAL

Pressing this key displays the calibration menu.

You can improve the accuracy of your measurements with calibration features built into the fault location software. You may correct for directivity, source match, and frequency response with the instrument calibration, or separately correct for cable loss and multiple responses.

Reset Cal to Default Selecting this function uses the default instrument calibration.

Calibrate Instrument This function guides you through recalibrating the analyzer with open/short/load standards. This calibration will correct for directivity, source match, and frequency response.

Velocity Factor This function allows you to enter a new velocity factor. Velocity factor is one of the two required parameters for cable calibration. Velocity factor is the speed of propagation of electrical signals in the cable relative to their speed in a vacuum. The velocity factor of your cable may be imprinted on the cable. If the velocity factor of your cable is not available, you may refer to Table B-1 for some typical values.

Cable Loss This function allows you to enter a new cable loss factor. Cable loss is one of the two required parameters for cable calibration. The cable loss of your cable may be imprinted on the cable. If not, you may refer to Table B-1 for some typical values.

CAUTION

The values in Table B-1 are typical only. Different manufacturers' cables may vary significantly from the table values.

Calibrate Cable This function lets you measure a known length of cable and automatically figures cable loss and velocity factors.

An alternative to entering the velocity factor and cable loss of your cable is to use the algorithm built into the fault location software to determine these values automatically. To use this function, you need a known length of cable of the same type being measured. The cable should be at least 30 feet long.

When this softkey is pressed, you will be prompted to enter the length of your cable and then to connect it, leaving the free end an open circuit. The software will determine values for velocity factor and cable loss based on the known distance down the line where the open circuit appears.

You will then have the option of having the software automatically modify the existing setup with the new values.

Cable Calibration Note

Cable loss is nonlinear with frequency. Therefore the apparent loss per 100 feet will change as the frequency range is changed. Velocity factor is also somewhat frequency dependent. You may wish to re-examine these values as the frequency limits are changed.

Key Reference

CAL

Multi Peak Threshold Allows entry of new multi-peak threshold. The fault location software can automatically compensate for multiple responses along the cable. For example, consider a cable with three successive faults along its length with reflection coefficients of 0.8. Without multi-peak correction, the measured response would be:

Peak	Measured Response	Calculation
Peak #1	0.8	
Peak #2	0.16	$(0.8 * (1 - 0.8))$
Peak #3	0.032	$(0.8 * ((1 - 0.8) - 0.16))$

With multi-peak correction, the measured response becomes:

Peak	Measured Response
Peak #1	0.8
Peak #2	0.8
Peak #3	0.8

Each subsequent peak is corrected based on the magnitude of the previous n peaks. Peak values are searched for above a user-defined threshold.

CAUTION

There is some uncertainty built into the measurement when multi-peak mode is enabled since the fault location software cannot always distinguish between real responses and response sidelobes which look like responses. To distinguish between side lobes and responses, various window selections should be tried (see **SYSTEM OPTIONS**), while looking for changes in the responses.

Multi Peak Corr OFF/ON Turns multi peak correction mode on or off.

CHAN 1

Pressing this key displays the menu for channel 1 display format.

Ch1: Return Loss Displays the channel 1 reflection response in dB. Return loss is the number of dB that the reflected signal is below the incident signal. Return loss can also be defined by the following formula:

$$RL = -20 \log \rho$$

Ch1: Refl. Coeff. Mag Displays the channel 1 reflection response as reflection coefficient magnitude. The reflection coefficient is the ratio of the reflected voltage wave to the incident voltage wave.

Ch1: SWR Displays the channel 1 reflection response as Standing Wave Ratio. Any two waves traveling in opposite directions (the incident and reflected for example) cause a "standing wave" to be formed on the transmission line. SWR is defined as the maximum voltage over the minimum voltage of the standing wave. SWR can also be mathematically derived from the reflection coefficient (ρ) with the following formula:

$$SWR = \frac{1 + \rho}{1 - \rho}$$

CHAN 2

Pressing this key displays the menu for channel 2 display format.

Ch2: Return Loss Displays the channel 2 reflection response in dB. Return loss is the number of dB that the reflected signal is below the incident signal. Return loss can also be defined by the following formula:

$$RL = -20\log\rho$$

Ch2: Refl. Coeff. Mag Displays the channel 2 reflection response as reflection coefficient magnitude. The reflection coefficient is the ratio of the reflected voltage wave to the incident voltage wave.

Ch2: SWR Displays the channel 2 reflection response as Standing Wave Ratio. Any two waves traveling in opposite directions (the incident and reflected for example) cause a “standing wave” to be formed on the transmission line. SWR is defined as the maximum voltage over the minimum voltage of the standing wave. SWR can also be mathematically derived from the reflection coefficient (ρ) with the following formula:

$$SWR = \frac{1 + \rho}{1 - \rho}$$

DISPLAY

Pressing this key accesses the Display menu. These softkeys allow you to customize the display layout to meet your needs.

Full Screen Displays both frequency (channel 1) and distance (channel 2) data traces on one full screen.

Split Screen Split screen is the default mode. The screen is split into two displays: frequency data (channel 1) is the top screen, and distance data (channel 2) is the bottom screen.

Marker Screen Another split screen mode where the top screen is a table containing marker data such as whether a particular marker is in use, and its position and value if it is. In marker screen mode the bottom screen is always channel 2 (distance data).

Graticule Turns the display graticule on or off.
ON/OFF

FORMAT

Allows you to change between displaying distance in feet and meters.

Feet Displays distance in units of feet.

Meters Displays distance in units of meters.

FREQ

Allows entry of center frequency. Center frequency is a parameter that is also asked for in the Guided Setup.

The center frequency should be set within the operating frequency bandwidth of the transmission line being tested. The center frequency can only be set to a value which will not result in the source going beyond its frequency limits.

Center Frequency When this softkey is pressed, you will be prompted to enter a new center frequency. You can retain the current center frequency if you wish by just pressing **ENTER**. The fault location software will select the proper frequency span for your measurement.

See Also

See Appendix C for an explanation of how the instrument determines the frequency span.

HARD COPY

Pressing this key displays the hard copy menu, which allows you to plot your fault location measurement results.

Plot to Default Plots the data to the selected output device. See your analyzer's *User's Guide* for information on setting up and configuring a plotter or printer to your analyzer.

Plot HPGL to Disk Instead of sending a displayed measurement result to a plotter or printer for a hardcopy output, you can save it as a Hewlett-Packard Graphics Language (HPGL) file to a disk in the network analyzer internal disk drive. The following procedure describes how to plot to a file.

1. Place a formatted disk in the network analyzer disk drive. If your disk is not formatted, press **SAVE RECALL** **Format Disk** to format the disk.
2. Press **HARD COPY** **Plot HPGL to Disk**.

The file is saved with a filename of PLOT#.HGL (where # is a number).

NOTE

If any markers are on, the marker table is added to the plot of the screen. See Figure 2-11 in Chapter 2 for an example.

MARKER

Pressing this key displays the marker menu and activates marker 1, putting it on the peak response on channel 2. There are eight markers available for use with the fault location software. These markers are only available for use with channel 2 distance data.

The **MARKER** need not be pressed to activate markers. You can activate a marker at any time by just selecting 1 through 8 on the instrument's keypad.

When a marker is initially selected, it is considered to be "active." Only one marker can be active at any given time. An active marker's triangle will be oriented point-down (∇) with its corresponding number above the triangle. Any other inactive displayed markers will have their triangles oriented point-up (\triangle) with their corresponding numbers below the triangle. The active marker can be manually moved at any time by rotating the instrument's front panel knob or by using the up and down arrow keys.

Active Mkr-->Max Places the active marker on the maximum point of the distance display. If all markers are off when this function is selected, it activates marker 1 and places it on the maximum point in the distance display.

Next Peak Right Moves the active marker to the next nearest peak to the right. The next peak must be > -60 dB, and the current peak difference to the next peak difference must be at least 1/2 of a vertical division. See Figure 3-1.

Next Peak Left Moves the active marker to the next nearest peak to the left. The next peak must be > -60 dB, and the current peak difference to the next peak difference must be at least 1/2 of a vertical division. See Figure 3-1.

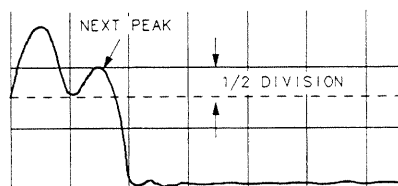

md55o

Figure 3-1.

Key Reference

MARKER

Delta Mkr OFF/ON Toggles the marker delta function on and off. The delta function makes the active marker the delta marker or reference point. The reference point is indicated by a small delta symbol below the marker icon. In delta marker mode, marker values are the offset values from the delta marker. For example, assume marker 1 is the delta marker: if marker 2 reads 2.5 feet and -9.3 dB, it is 2.5 feet away from and 9.3 dB below marker 1.

Active Mkr Off Turns only the active marker off.

All Off Turns all markers off.

More Mkrs Briefly displays the following message: "The number pad selects markers 1 through 8. To move markers, use the front panel knob or the up and down arrow keys."

See Also For an example of marker usage, see "Interpret the Measurement" in Chapter 2.

MENU

This menu allows you to select the number of data trace points. Fewer trace points provides less resolution but faster sweep speeds and vice versa. This menu also allows entry of the start and stop distance.

101 Points Selects 101 data tracepoints.

201 Points Selects 201 data tracepoints. This is the default number of tracepoints.

401 Points Selects 401 data tracepoints.

Start Distance Allows entry of a new start distance. Start distance is a parameter that is also asked for in the Guided Setup. When this softkey is pressed, you will be prompted to enter a new start distance. You can retain the current start distance if you wish by just pressing **ENTER**.

Stop Distance Allows the entry of a new stop distance. Stop distance is a parameter that is also asked for in the Guided Setup. When this softkey is pressed, you will be prompted to enter a new stop distance. The maximum allowable entry for stop distance is 9999.999 feet or 9999.99 meters. You can retain the current stop distance if you wish by just pressing **ENTER**.

NOTE

Changing start and/or stop distance will change the frequency span. See Appendix C for detailed information on the relationship between distance range and frequency span.

POWER

Pressing this key allows you to change the power level.

Power Level Allows you to set the power level at the output port. The default power level is 0 dBm.

SAVE RECALL

Pressing this key displays the Save Recall menu.

Save Setup/Data Saves the current instrument setup and data to a formatted disk in the internal disk drive. You will be prompted to enter a file name.

Recall Setup/Data Recalls setup and data from an internal floppy disk to the display. Use the front panel knob or the up and down arrow keys to select a file to recall.

Save ASCII Trace Data Saves trace data in ASCII format. This data is spreadsheet compatible.

Delete Files Allows you to delete files from the disk. Use the front panel knob or the up and down arrow keys to select a file to delete.

Format Disk Formats a floppy disk in the instrument's disk drive in DOS format.

SCALE

Pressing this key displays the scale menu.

Autoscale Scales the data trace vertically to fit within the graticule area of the display on the active channel only.

Scale/Div Allows you to enter the appropriate desired units per vertical display division for the active channel. For example, if scale/div is 10 dB, each graticule line is 10 dB higher than the one below it.

Reference Level Allows you to set the value of the reference line on the active channel. The line is indicated on the display by a small triangle (▶) at the left edge of the graticule. The following table shows the minimum, maximum and default reference level values for each measurement mode.

Measurement Mode	Minimum	Maximum	Default
Return Loss (dB)	-100	0	10
Reflection Coefficient	0	.5	10
SWR	-500	1	500

Reference Position Allows you to set the position of the reference line on the active channel. Setting the reference position to 10 puts the line on the top graticule of the display, setting the position to 0 puts it on the bottom graticule. The default position is 9.

Start Distance Allows entry of a new start distance. Start distance is a parameter that is also asked for in the Guided Setup. When this softkey is pressed, you will be prompted to enter a new start distance. You can retain the current start distance if you wish by just pressing **ENTER**.

Stop Distance Allows the entry of a new stop distance. Stop distance is a parameter that is also asked for in the Guided Setup. When this softkey is pressed, you will be prompted to enter a new stop distance. The maximum allowable entry for stop distance is 9999.999 feet or 9999.99 meters. You can retain the current stop distance if you wish by just pressing **ENTER**.

NOTE

Changing start and/or stop distance will change the frequency span. See Appendix C for detailed information on the relationship between distance range and frequency span.

SWEEP

Pressing this key displays the sweep menu.

Continuous This is the default sweep mode. The analyzer begins its next sweep at the conclusion of the current sweep.

Hold Stops the current sweep and holds it until **Continuous** or **Single** is selected.

Single Triggers one complete sweep if **Hold** has been selected, and holds until retriggered with either **Continuous** or **Single**. Has no effect if instrument is currently in **Continuous** mode. (**Hold** must be pressed before **Single** can be used.)

SYSTEM OPTIONS

This menu allows you to select windowing options, set test limit lines, and configure the display with a title and date and time stamp.

Window The fault location software provides a windowing feature that makes fault measurements more useful for isolating and identifying individual responses. Windowing is needed because of the abrupt transitions in a frequency domain response at the start and stop frequencies. The band limiting of a frequency domain response causes overshoot and ringing in the distance domain response. This gives a non-windowed impulse stimulus to have a $\sin(wt)/wt$ shape where $w = \pi/(\text{frequency span})$. This has two effects that limit the usefulness of the fault location measurement:

1. **Finite impulse width (or rise time):** This limits the ability to resolve between two closely spaced responses. The effects of the finite impulse are improved as the frequency span is increased.
2. **Sidelobes:** The impulse sidelobes limit the dynamic range of the time domain measurement by hiding low-level responses within the sidelobes of higher level responses. The effects of sidelobes can be improved by windowing.

Windowing improves the dynamic range of a distance domain measurement by filtering the frequency domain data prior to converting to the distance domain, producing an impulse response that has lower sidelobes. This makes it much easier to see distance domain responses that are different in magnitude. This sidelobe reduction is achieved, however, at the expense of increased impulse width.

Key Reference

SYSTEM OPTIONS

The following options are available under the Window menu:

Minimum

This is essentially no window. It gives the highest sidelobes and the narrowest impulse response.

Medium

This is the default selection. Selecting medium provides reduced sidelobes.

Maximum

This selection provides minimum sidelobes but the widest impulse response.

Cancel

Returns to the **SYSTEM OPTIONS** menu.

Limit Line Allows entry of a test limit line. When testing cables you may have a particular specification you are testing to. For example, you may have a specification that the return loss on your cable must be -30 dB or better. If you set the limit line to -30 , you can just connect the cable and immediately see whether your cable meets your specification or not. The analyzer will indicate "PASS" if all responses are below the limit line, and will indicate "FAIL" if any responses fall above the limit line.

See Also

For an example of limit line usage, see "Interpret the Measurement" in Chapter 2.

Title and Clock On Displays user-entered title on channel 2 display and date/time information on channel 1 display.

Title and Clock Off Turns off display of title and date/time information.

Change Title Allows user to enter or change a title. Use the front panel knob and/or up and down arrow keys to select characters or words for your title. Press **Select Char/Word** after each character or word selection and press **ENTER** when done selecting characters and/or words.

Performance Summary and
Characteristics

Performance Summary and Characteristics

This chapter contains performance data for the fault location measurement software. For complete specification and characteristic information for your analyzer, see your analyzer's *User's Guide*.

General Performance Characteristics

Measurements	Return loss [dB] versus distance Reflection coefficient magnitude versus distance SWR versus distance
Dynamic Range	40 dB (based on system directivity after calibration)
Windowing	Minimum, medium and maximum windows are available for optimizing distance response data
Amplitude Accuracy¹	± 2.5 dB typical (minimum windowing) ± 1.2 dB typical (medium windowing) ± 0.4 dB typical (maximum windowing)
Data Correction	Data is normalized to the open/short/load response at the output port. Data correction for line losses and preceding mismatches is also available.
Measurement and Data Storage	You may store and retrieve setups and data onto or from a data disk. Typically, you may store as many as 40 setups onto a disk. You may also store data in a format compatible with popular PC-based spreadsheet software. Data may also be stored in HPGL graphics format.
Markers	Eight independently controlled markers can be used to display return loss, reflection coefficient, or SWR versus distance.
Limit Lines	Limit lines may be entered for comparison to specification limits and pass/fail testing.
Remote Programming	The analyzer running the fault location application can be controlled from an external controller through the IEEE 488.2 HP-IB port. Use standard SCPI program subsystem commands to control the fault location task. See Appendix D for an external program listing.
Hard Copy	The analyzer can be configured to output print or plot data to the serial port, the parallel port, the HP-IB port, or to a file. The data can be either a graph or a tabular listing of data points. Tabular listings include limit-line information and pass/fail margins, point by point.
Fault Range	Up to 9999.99 meters. (See Table 4-1 and Table 4-2.)
Resolution	Down to 0.195% of range. (See Table 4-1 and Table 4-2.)

¹ Inaccurate cable loss factor and/or multiple fault correction may introduce additional error uncertainties.

Distance Range and Resolution

Resolution improves as the range is shortened and as the number of measurement points are increased. (See the following tables and graphs.) Distance is displayed in feet or meters. Typical range is limited by transmission line losses.

Range

Maximum range is a function of the velocity factor (V_f), frequency bandwidth (BW), the velocity of light in a vacuum ($c = 2.99796 \times 10^8$ mtrs/sec), and the number of measurement points (NP), and is determined using the following formula:

$$Range = \frac{V_f(c)(NP - 1)}{2(BW)}$$

Resolution

Maximum resolution is a function of the velocity factor (V_f), frequency bandwidth (BW), sampling factor (N_s : 128 for 101 points, 256 for 201 points, and 512 for 401 points), the velocity of light in a vacuum ($c = 2.99796 \times 10^8$ mtrs/sec), and the number of measurement points (NP), and is determined using the following formula:

$$Resolution = \frac{V_f(c)(NP - 1)}{2(BW)(N_s)} = \frac{Range}{N_s}$$

Typical Distance Data in Feet

Table 4-1.
Fault Location Distance Range or Maximum Distance (in feet)
Versus Resolution at 201 Points*

Frequency Span (MHz)	Distance Range (feet)	Resolution (feet)	Frequency Span (MHz)	Distance Range (feet)	Resolution (feet)
Velocity Factor = 0.5			Velocity Factor = 0.8		
1300	37.18	0.15	1300	59.49	0.23
650	74.36	0.29	650	118.97	0.46
200	241.67	0.94	200	386.67	1.51
60	805.55	3.15	60	1288.88	5.03
20	2416.66	9.44	20	3866.65	15.10
Velocity Factor = 0.6			Velocity Factor = 0.9		
1300	44.62	0.17	1300	66.92	0.26
650	89.23	0.35	650	133.85	0.52
200	290.00	1.13	200	435.00	1.70
60	966.66	3.78	60	1450.00	5.66
20	2899.99	11.33	20	4349.99	16.99
Velocity Factor = 0.7			Velocity Factor = 1.0		
1300	52.05	0.20	1300	74.36	0.29
650	104.10	0.41	650	148.72	0.58
200	338.33	1.32	200	483.33	1.89
60	1127.77	4.41	60	1611.11	6.29
20	3383.32	13.22	20	4833.32	18.88

* See Appendix B for typical coaxial cable characteristics including velocity factor.

Performance Summary and
Characteristics
Distance Range and Resolution

The following two graphs are plots of maximum distance versus frequency span and resolution versus frequency span using data from Table 4-1. Please note that data is plotted only for velocity factors of 0.5 and 1.0.

Max Distance vs Frequency Span (201 pts)

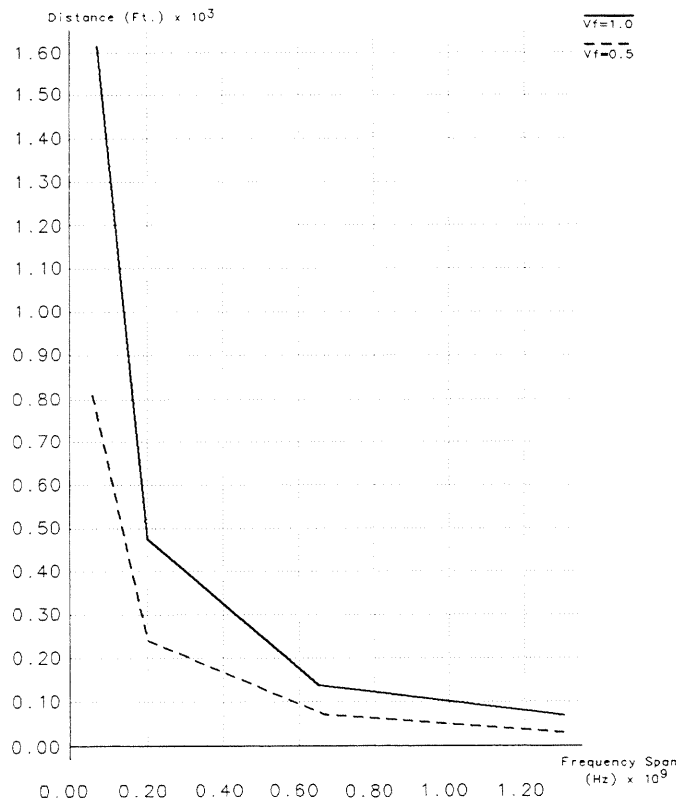

md67a

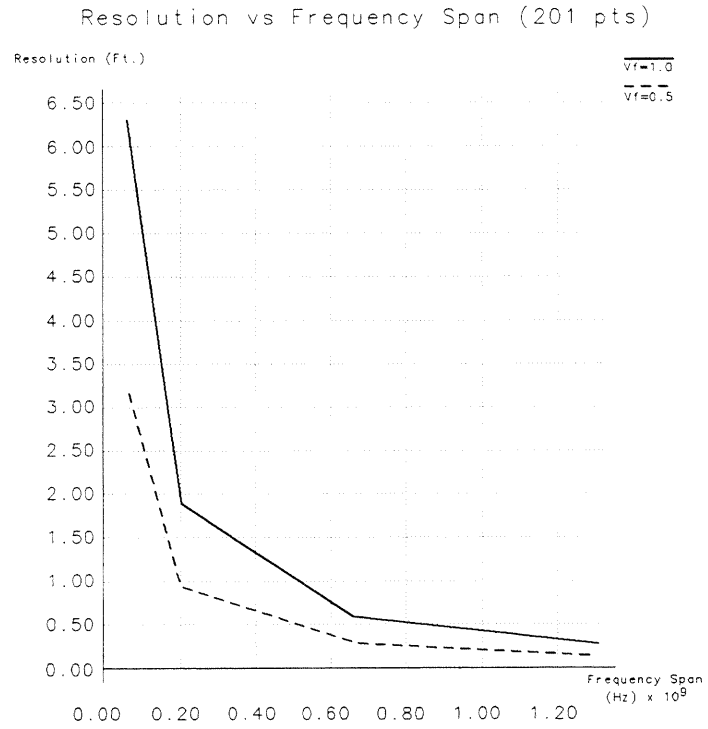

md68a

Performance Summary and
 Characteristics
Distance Range and Resolution

Distance Data in Meters

Table 4-2.
Fault Location Distance Range or Maximum Distance (in meters)
Versus Resolution at 201 Points*

Frequency Span (MHz)	Distance Range (meters)	Resolution (meters)	Frequency Span (MHz)	Distance Range (meters)	Resolution (meters)
Velocity Factor = 0.5			Velocity Factor = 0.8		
1300	11.59	0.05	1300	18.54	0.07
650	23.18	0.09	650	37.08	0.14
200	75.32	0.29	200	120.52	0.47
60	251.08	0.98	60	401.72	1.57
20	753.23	2.94	20	1205.17	4.71
Velocity Factor = 0.6			Velocity Factor = 0.9		
1300	13.91	0.05	1300	20.86	0.08
650	27.81	0.11	650	41.72	0.16
200	90.39	0.35	200	135.58	0.53
60	301.29	1.18	60	451.94	1.77
20	903.87	3.53	20	1355.81	5.30
Velocity Factor = 0.7			Velocity Factor = 1.0		
1300	16.22	0.06	1300	23.18	0.09
650	32.45	0.13	650	46.35	0.18
200	105.45	0.41	200	150.65	0.59
60	351.51	1.37	60	502.15	1.96
20	1054.52	4.12	20	1506.46	5.88

* See Appendix B for typical coaxial cable characteristics including velocity factor.

Performance Summary and
Characteristics
Distance Range and Resolution

The following two graphs are plots of maximum distance versus frequency span and resolution versus frequency span using data from Table 4-2. Please note that data is plotted only for velocity factors of 0.5 and 1.0.

Max Distance vs Frequency Span at 201 points.

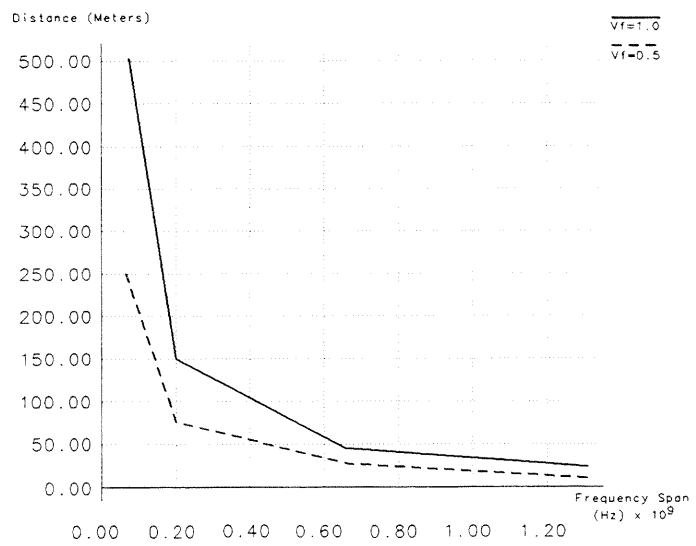

md69a

Performance Summary and
Characteristics

Distance Range and Resolution

Resolution vs Frequency Span (201 pts)

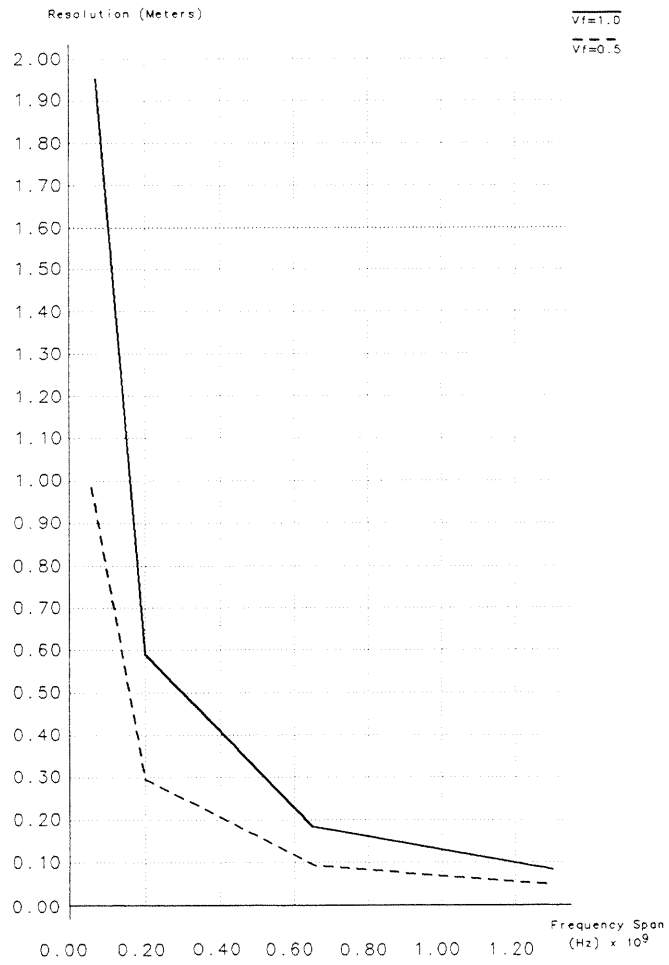

md610a

License Agreement and
Limited Warranty

License Agreement and Limited Warranty

Important

Please carefully read this License Agreement before opening the media envelope or operating the equipment. Rights in the software are offered only on the condition that the Customer agrees to all terms and conditions of the License Agreement. Opening the media envelope or operating the equipment indicates your acceptance of these terms and conditions. If you do not agree to the License Agreement, you may return the unopened package for a full refund.

License Agreement

In return for payment of the applicable fee, Hewlett-Packard grants the Customer a license in the software, until terminated, subject to the following:

Use

- Customer may use the software on one instrument.
- Customer may not reverse assemble or decompile the software.

Copies and Adaptations

- Customer may make copies or adaptations of the software:
 - For archival purposes, or
 - When copying or adaptation is an essential step in the use of the software with a computer so long as the copies and adaptations are used in no other manner.
- Customer has no other rights to copy unless they acquire an appropriate license to reproduce which is available from Hewlett-Packard for some software.
- Customer agrees that no warranty, free installation, or free training is provided by Hewlett-Packard for any copies or adaptations made by Customer.
- All copies and adaptations of the software must bear the copyright notices(s) contained in or on the original.

License Agreement

Ownership

- Customer agrees that they do not have any title or ownership of the software, other than ownership of the physical media.
- Customer acknowledges and agrees that the software is copyrighted and protected under the copyright laws.
- Customer acknowledges and agrees that the software may have been developed by a third party software supplier named in the copyright notice(s) included with the software, who shall be authorized to hold the Customer responsible for any copyright infringement or violation of this License Agreement.

Transfer of Rights in Software

- Customer may transfer rights in the software to a third party only as part of the transfer of all their rights and only if Customer obtains the prior agreement of the third party to be bound by the terms of this License Agreement.
- Upon such a transfer, Customer agrees that their rights in the software are terminated and that they will either destroy their copies and adaptations or deliver them to the third party.
- Transfer to a U.S. government department or agency or to a prime or lower tier contractor in connection with a U.S. government contract shall be made only upon their prior written agreement to terms required by Hewlett-Packard.

Sublicensing and Distribution

- Customer may not sublicense the software or distribute copies or adaptations of the software to the public in physical media or by telecommunication without the prior written consent of Hewlett-Packard.

Termination

- Hewlett-Packard may terminate this software license for failure to comply with any of these terms provided Hewlett-Packard has requested Customer to cure the failure and Customer has failed to do so within thirty (30) days of such notice.

Updates and Upgrades

- Customer agrees that the software does not include future updates and upgrades which may be available from HP under a separate support agreement.

Export

- Customer agrees not to export or re-export the software or any copy or adaptation in violation of the U.S. Export Administration regulations or other applicable regulations.

Limited Warranty

Software

Hewlett-Packard warrants for a period of 1 year from the date of purchase that the software product will execute its programming instructions when properly installed on the instrument indicated on this package. Hewlett-Packard does not warrant that the operation of the software will be uninterrupted or error free. In the event that this software product fails to execute its programming instructions during the warranty period, customer's remedy shall be to return the media to Hewlett-Packard for replacement. Should Hewlett-Packard be unable to replace the media within a reasonable amount of time, Customer's alternate remedy shall be a refund of the purchase price upon return of the product and all copies.

Media

Hewlett-Packard warrants the media upon which this product is recorded to be free from defects in materials and workmanship under normal use for a period of 1 year from the date of purchase. In the event any media prove to be defective during the warranty period, Customer's remedy shall be to return the media to Hewlett-Packard for replacement. Should Hewlett-Packard be unable to replace the media within a reasonable amount of time, Customer's alternate remedy shall be a refund of the purchase price upon return of the product and all copies.

Notice of Warranty Claims

Customer must notify Hewlett-Packard in writing of any warranty claim not later than thirty (30) days after the expiration of the warranty period.

Limitation of Warranty

Hewlett-Packard makes no other express warranty, whether written or oral, with respect to this product. Any implied warranty of merchantability or fitness is limited to the 1 year duration of this written warranty. This warranty gives specific legal rights, and Customer may also have other rights which vary from state to state, or province to province.

Exclusive Remedies

The remedies provided above are Customer's sole and exclusive remedies. In no event shall Hewlett-Packard be liable for any direct, indirect, special, incidental, or consequential damages (including lost profit) whether based on warranty, contract, tort, or any other legal theory.

Warranty Service

Warranty service may be obtained from the nearest Hewlett-Packard sales office or other location indicated in the owner's manual or service booklet.

A

HP 8711A Option K20:
Installing the Firmware

HP 8711A Option K20: Installing the Firmware

This procedure is necessary only if you have ordered HP 8711A option K20.

NOTE

If you have a "B" model analyzer, or if you ordered option H20, you received an analyzer already configured with the correct firmware. Do not perform this procedure if you ordered option H20, or if your analyzer is an HP 8711B/12B/13B/14B.

To load the firmware you will need the appropriate firmware disk (see "Step 3. Determine the Correct Firmware for Your Analyzer") as well as a blank disk to store the instrument's correction constants on during firmware installation.

To correctly install the firmware, the following steps should be performed in the order they appear.

CAUTION

It is extremely important that the analyzer's correction constants are stored to a disk before the new firmware is loaded.

Step 1. Format the Blank Disk

This section may be omitted if the blank disk you have is already formatted in either DOS or LIF format, *or* if you have the correction constant data for your instrument already available on a disk.

1. Make sure the analyzer's internal disk drive is empty and cycle the power.
2. Label the blank disk with "CC DATA" and the serial number of the analyzer.
3. Insert the disk into the analyzer's internal disk drive, making sure first that the disk is not write-protected.
4. Format the disk by selecting the following: **SAVE RECALL**, **File Utilities**, **Format Disk**, **Format Int Disk**, **YES**.
5. Formatting will take approximately 2.5 minutes.

Step 2. Store the Analyzer's Correction Constants To the Disk

This step may be omitted if you have current correction constant data already available on a disk.

1. With a formatted disk in the disk drive, press: **SYSTEM OPTIONS**, **Service**, **Update Corr Const**, **Store CC to Disk**.
2. When done, remove this disk and set it aside. This is a copy of the correction constants unique to your analyzer. They will need to be reloaded into the analyzer after the new firmware is installed.

Step 3. Determine the Correct Firmware for Your Analyzer

Two firmware disks were supplied with your shipment:

Revision A.03.01 — HP part number 08711-10017

Revision A.02.03 — HP part number 08711-10014

You must use the following procedure to determine which revision of firmware to install in your analyzer.

1. If your analyzer has a serial number ending with 802 or greater, you will be using Revision A.03.01 (part number 08711-10017). Obtain this disk and proceed with “Step 4. Load the New Firmware.”
2. Analyzers prior to serial number 802 were shipped with 1.5 MB of flash EPROM which is incompatible with firmware revisions A.03.00 and above. However, if you have one of these analyzers, it *may* contain sufficient EPROM to run the newer version of firmware if the analyzer has ever been upgraded or had its A2 CPU board replaced.
3. To determine the amount of flash EPROM contained in your particular analyzer, cycle the power on the analyzer and watch the display.
4. During the power-up routine the analyzer should display the heading “Program ROM.” If a value of 2 MB is indicated, then you will be using Revision A.03.01 (part number 08711-10017).
5. If any other value (or no value) is indicated, you need to use Revision A.02.03 (part number 08711-10014).

Step 4. Load the New Firmware

1. Insert the firmware disk (determined in Step 3, above) into the disk drive and cycle the power on the analyzer.
2. Upon power-up you will see a message indicating that a firmware disk has been found.

CAUTION

Do not proceed unless you have completed the previous procedure entitled "Step 2. Store the Analyzer's Correction Constants To the Disk," *or* you are certain that you already have the instrument's correction constant data available on a disk.

3. Press **BEGIN**.
4. The new firmware will now automatically load. The process will take about five minutes.

Step 5. Restore the Correction Constants

1. Remove the firmware disk from the analyzer's disk drive.
 2. Cycle the power on the analyzer.
 3. Insert the "CC DATA" disk into the analyzer's disk drive.
 4. When prompted, press `Install CC From Disk`.
 5. Remove the disk and cycle the power on the analyzer.
- The firmware installation is now complete.

B

Cable Loss and Velocity
Factor Table

Cable Loss and Velocity Factor Table

Table B-1. Cable Loss and Velocity Factor Table *

Coaxial Cable Nominal Loss Characteristics dB per Hundred Feet, Frequency in GHz #										
RG/U	Relative Velocity	.01	.05	.10	.20	.40	1	3	5	10
5, 5A, 5B, 6A, 6B, 212	.659	.80	1.40	2.90	4.30	6.40	11.00	22.00	30.00	52.00
7	.659	.66	1.50	2.20	3.20	4.60	9.00	19.00	28.00	47.00
8, 8A, 10A, 70, 213, 215	.659	.66	1.50	2.20	3.20	4.60	9.00	19.00	28.00	47.00
9, 9A, 9B, 214	.659	.66	1.50	2.20	3.20	4.60	9.00	19.00	28.00	47.00
11, 11A, 12, 12A, 13, 13A, 216	.659	.66	1.50	2.20	3.20	4.60	9.00	19.00	28.00	-
14, 14A, 74, 74A, 217, 224, 293, 293A, 388	.659	.41	1.00	1.40	2.10	3.10	5.80	13.00	19.00	31.00
17, 17A, 18, 18A, 84A, 85A, 177, 218, 219,295	.659	.23	.56	.81	1.20	1.90	3.80	9.00	13.50	-
19, 19A, 20, 20A, 147, 220, 221	.659	.17	.43	.63	.94	1.50	3.00	7.00	-	-
21, 21A, 222	.659	4.40	9.40	12.90	18.20	26.50	44.00	87.00	-	-
22, 22B, 111, 111A	.659	1.20	2.80	4.20	6.30	9.60	-	-	-	-
29	.659	1.35	3.00	4.30	6.00	8.80	16.50	36.00	51.00	85.00
34, 34A, 34B	.659	.32	.90	1.40	2.10	3.30	5.80	16.00	28.00	-
35, 35A, 35B, 164	.659	.24	.60	.90	1.30	2.00	3.70	8.90	15.00	-
54, 54A	.659	.90	2.20	3.30	4.60	6.90	13.10	26.20	35.00	-
55, 55A, 55B, 223	.659	1.35	3.00	4.30	6.00	8.80	16.50	36.00	51.00	85.00
57, 57A, 130, 131, 294, 294A	.659	.65	1.60	2.40	3.60	5.20	10.00	21.20	-	-
58, 58B	.659	1.20	3.10	4.60	7.00	10.00	17.50	38.00	-	-
58A, 58C	.659	1.40	3.30	4.90	7.30	11.00	20.00	41.00	-	-

* Times Wire and Cable, *RF Transmission Line Catalog and Handbook*. Catalog TL-6, 1972.
CONDITIONS: Ambient 20 °C

Table B-1. Cable Loss and Velocity Factor Table (continued)

RG/U	Relative Velocity	.01	.05	.10	.20	.40	1	3	5	10
59, 59A, 59B	.659	1.10	2.30	3.30	4.70	6.70	11.50	25.50	41.00	-
62, 62A, 71, 71A, 71B	.84	.90	1.90	2.80	3.70	5.20	8.50	18.40	29.50	-
63, 63B, 79, 79B	.84	.50	1.10	1.50	2.30	3.40	5.70	12.20	20.90	-
87A, 115, 115A, 116, 165, 166, 225, 227, 393, 397	.695	.60	1.40	2.10	3.10	4.50	7.50	14.00	21.00	35.00
94	.695	.60	1.30	2.00	2.90	4.20	7.10	13.00	19.00	33.00
94A, 226	.695	.40	1.00	1.50	2.10	3.00	5.00	10.00	15.00	27.00
108, 108A	.659	2.30	5.20	7.50	11.00	16.00	26.20	54.00	-	-
117, 117A, 118, 211, 211A, 228, 228A	.695	.25	.61	.90	1.40	2.00	3.40	7.50	11.50	-
119, 120	.695	.50	1.05	1.60	2.20	3.10	5.10	10.20	15.20	27.30
122	.659	1.60	4.40	6.90	11.00	16.60	29.20	57.20	89.00	-
140, 141, 141A, 142, 142B, 159, 302, 303, 400, 402	.695	1.20	2.70	3.90	5.50	8.00	13.00	26.00	36.00	62.00
143, 143A, 304, 401	.695	.85	1.80	2.50	3.80	5.70	9.70	18.10	26.10	40.70
144	.695	.38	1.00	1.60	2.30	3.80	7.00	15.10	-	-
161, 179, 179A, 179B, 187, 187A	.695	5.00	7.20	9.80	12.70	15.80	25.00	43.00	62.50	135.00
174, 174A	.659	3.80	6.50	8.90	12.00	17.50	31.00	64.30	97.00	185.00
178, 178A, 178B, 196, 196A, 403, 404	.695	5.30	10.00	13.30	20.00	27.50	45.00	78.00	115.00	172.00
180, 180A, 180B, 195, 195A	.695	3.10	4.20	5.10	7.30	10.40	16.50	36.00	49.00	89.00
183	.91	.18	.38	.53	.78	1.20	1.90	3.70	5.00	-
188, 188A, 316	.695	3.80	7.90	11.50	15.00	20.00	30.00	58.00	79.00	133.00
235	.695	.60	1.40	2.10	3.10	4.50	7.50	14.00	21.00	35.00
306, 306A, 336	.80	.15	.33	.52	.80	1.30	2.30	5.20	7.80	-
307, 307A	.80	1.20	2.70	3.80	5.40	7.50	12.00	-	-	-
323, 324, 332, 333, 376	.80	.15	.32	.50	.75	1.20	2.10	4.70	6.50	-
334, 335	.80	.25	.60	.85	1.20	1.90	3.50	7.00	10.00	18.00
360	.80	.18	.40	.60	.90	1.50	2.50	5.30	7.50	

C

———— Measurement Theory

Measurement Theory

This section explains how the analyzer converts frequency domain data to distance domain data. It also explains the relationship between start distance, stop distance and frequency span.

How the Analyzer Converts Frequency Data to Distance Data

The analyzer performs swept frequency measurements of return loss, then performs an inverse Fourier Transform on the result to convert to the distance domain. Other cable corrections are done to correct for cable loss and multiple faults.

Fundamentally, the analyzer has a tuned receiver, measuring at discrete frequencies. In order to use the analyzer's basic high performance to make distance domain measurements, the frequency domain data has to be converted to the distance domain.

The way to do this is to build the impulse out of the frequencies measured. The process is one of measuring many different frequencies and adding the scaled responses back together.

For example, an impulse can be synthesized from three sine waves or three measured points. The first point is F_0 , the fundamental frequency of an impulse train spectrum. The impulse train will repeat at one over the frequency of the fundamental. We then add in the first harmonic ($2 * F_0$). The impulse will start to become defined. As the second harmonic ($3 * F_0$) is added in, the increasing bandwidth makes a narrower pulse. The more points used, the more bandwidth included, and the narrower the impulse will become.

The process of adding sine waves is expressed mathematically by the inverse discrete Fourier transform (inverse DFT).

You can use this information to build an impulse response. Suppose that before adding the sine waves back together, we send each one out to a device under test, and measure the magnitude and phase offset of the return sine wave. As long as the device is linear, it does not matter if we send the whole impulse at once, or if we only send one spectral piece at a time: we will still get the same response.

Start/Stop Distance and Frequency Span Explanation

When the analyzer is set up for a measurement, you determine the center frequency, and start and stop distances for the measurement. The fault location software uses the distance range (start distance minus stop distance) to determine the frequency span, which in turn, determines the start and stop frequencies. Note that the only user-chosen frequency parameter is center frequency. Changes to the distance range do not affect the user-chosen center frequency setting.

The fault location software will attempt to set the frequency span to the setting required for the distance range. The maximum setting for the frequency span cannot exceed a "legal" setting. For instance, the start frequency cannot be lower than the analyzer's low frequency limit, and the stop frequency cannot be higher than the analyzer's high frequency limit.

When the distance range requires a larger span than can be legally set, the frequency span is set to the maximum legal setting and extra processing is done on the frequency domain data to provide the response in the distance domain. This extra processing is called Zoom mode. The "Zoom" message will appear in the Channel 2 annotation on the screen.

Zoom mode is a way to create a distance domain response with arbitrary start and stop distances for a given frequency span. Because Zoom mode requires more processing, sweep update rates will slow down in this mode. The software will generally attempt to set frequency span to a legal setting for the requested distance range before switching to Zoom mode.

D

External Programming

External Programming

The BASIC program, filename "FAULTEXT," runs on a Hewlett-Packard workstation equipped with HP BASIC, or a personal computer equipped with HP Instrument BASIC (IBASIC) for Windows™. The program allows the external computer to control the analyzer in order to perform fault location measurements remotely over Hewlett-Packard Interface Bus (HP-IB). Using this configuration, the external computer can perform fault location measurements, and query the measurement data for statistical or archival purposes. This program is provided on the software disk you received with your shipment (HP part number 08711-10013).

See the programming information provided in your analyzer's *Programming Guide* for information on programming.

Index

Index

- 1 101 points, 3-21
- 2 201 points, 3-21
- 4 401 points, 3-21
- A activating markers, 3-19
 - active marker, 3-19
 - active mkr-->max, 3-19
 - active mkr off, 3-20
 - agreement
 - software license, 5-2
 - all off, 3-20
 - analyzer calibration, 2-6, 3-10
 - ASCII data
 - how to save, 3-23
 - autoscale, 3-24
 - AUTOST program, 1-3, 1-4
 - average factor, 3-9
 - averaging, 3-9
 - averaging, how it works, 3-9
 - AVG**, 3-9
- B blank disk
 - how to format, A-3
 - blanking the graticule, 3-15
- C cable calibration, 3-10, 3-11
 - cable loss, 3-10
 - cable loss table, B-2
 - cable parameters
 - typical, B-2
 - cable specifications, 2-5
 - CAL**, 3-10
 - calibrate cable, 3-11
 - calibrate instrument, 3-10
 - calibration, 2-6
 - calibration menu, 3-10
 - cancel, 3-28

- center frequency, 3-17
- CHAN 1**, 3-13
- CHAN 2**, 3-14
- change title, 3-29
- changing distance units, 3-16
- changing frequency, 3-17
- continue, 1-11
- continuous, 3-26
- control
 - external, D-2
- copying correction constants, A-4
- correction, 2-6, 3-10
 - multi peak, 3-12
- correction constants, A-4
 - to restore, A-7

D data

- ASCII, 3-23
- how to recall, 3-23
- how to save, 3-23
- scaling, 3-24

data correction, 4-3

data tracepoints, 3-21

date/time display, 3-29

default calibration, 2-6, 3-10

default reference levels, 3-24

default setup, 1-8

Default Setup, 1-8

default state, 1-8

default values for parameters, 1-8

delete files, 3-23

delta mkr off/on, 3-20

diagram

- setup, 1-11

diagram setup, 2-7

directivity calibration, 3-10

disk

- format, 3-18
- formatting, A-3
- software, 1-3
- to format, 3-23

DISPLAY, 3-15

display date/time and title, 3-29

displaying the marker table, 3-15

distance

- start, 3-21, 3-24
- stop, 3-21, 3-25

distance units, 3-16

- distance vs bandwidth (in feet)
 - graph, 4-6
 - distance vs bandwidth (in meters)
 - graph, 4-9
 - distance vs resolution (in feet)
 - table, 4-5
 - distance vs resolution (in meters)
 - table, 4-8
 - documentation outline, vi
 - dynamic range, 3-27, 4-3
- E**
- equipment setup, 1-11, 2-7
 - example measurements, 2-11-19
 - exiting the program, 1-12
 - external control, D-2
 - external programming, D-2
- F**
- FAULTTEXT program, 1-3, D-2
 - fault location theory, 2-3
 - FAULT program, 1-3
 - feet, 3-16
 - file
 - plots, 3-18
 - to delete, 3-23
 - firmware
 - choosing the correct disk, A-5
 - firmware installation, A-2-7
 - FORMAT**, 3-16
 - format disk, 3-23
 - formatting a disk, 3-18, A-3
 - FREQ**, 3-17
 - frequency response calibration, 3-10
 - frequency span, 3-17
 - front panel key conventions, vi
- G**
- graticule on/off, 3-15
 - guided setup, 1-9, 2-5
 - parameter default values, 1-8
 - Guided Setup**, 1-9
 - guided setup parameters, 2-5

- H H20 option, iv
 - hard copy, 4-3
 - HARD COPY**, 3-18
 - hardkey conventions, vi
 - hardkeys, 3-2-29
 - hold, 3-26

- I IBASIC option, 1-2
 - indicator
 - reference line, 3-24
 - installing the firmware, A-2-7
 - instrument calibration, 2-6, 3-10
 - instrument setup
 - how to save, 3-23
 - instrument setups
 - how to recall, 3-23
 - interpreting measurements, 2-8

- K K20 option, iv
 - key conventions, vi
 - keys, 3-2-29

- L limited warranty, 5-6
 - limit line, 3-28
 - example, 2-10
 - loading the program, 1-5
 - loss
 - cable, 3-10

- M making measurements, 2-4
 - marker
 - example, 2-9
 - MARKER**, 3-19
 - marker data, 3-15
 - marker menu, 3-19
 - marker offsets, 3-20
 - marker reference, 3-20
 - markers
 - moving manually, 3-19
 - marker screen, 3-15
 - marker to maximum, 3-19
 - maximum, 3-28
 - maximum window, 3-28
 - measurement basics, 2-3
 - measurement examples, 2-11-19
 - measurement interpretation, 2-8

- measurements
 - how to make, 2-4
- measurement setup, 2-7
- medium, 3-28
- medium window, 3-28
- MENU**, 3-21
- menumaps, 3-3
- meters, 3-16
- minimum, 3-28
- minimum window, 3-28
- more mkr, 3-20
- moving markers, 3-19
- multi peak threshold, 3-12
- multiple responses, 3-12

N next peak

- example, 2-9
- next peak left, 3-19
- next peak right, 3-19
- noise reduction, 3-9
- normal operation, 1-12
- number of points, 3-21

O offset marker, 3-20

- operation
 - normal, 1-12
 - option 1C2, 1-2
 - option H20, iv
 - option K20, iv
 - options, iv
- outline
 - documentation, vi
- output power, 3-22

P pass/fail line

- example, 2-10

- pass/fail testing, 3-28
- pause, 1-11
- PAUSE**, 1-11
- pausing the program, 1-11
- performance characteristics, 4-3
- plot files, 3-18
- plot HPGL to disk, 3-18
- plotting data, 3-18
- plot to default, 3-18
- POWER**, 3-22
- power level, 3-22

- preset, 1-12
- printing data, 3-18
- program
 - exiting, 1-12
 - to load from front panel, 1-5
 - to run, 1-5
- program defaults, 1-8
- programs on disk, 1-3

R random noise reduction, 3-9

- recalibrating, 3-10
- recall setup/data, 3-23
- reference level, 3-24
- reference level defaults, 3-24
- reference line, 3-24
 - positioning, 3-24
- reference line indicator, 3-24
- reference marker, 3-20
- reference position, 3-24
- refl. coeff. mag, 3-13, 3-14
- reflection coefficient, 2-3
- reflection coefficient magnitude, 3-13, 3-14
- remote programming, 4-3
- reset cal to default, 3-10
- resolution vs bandwidth (in feet)
 - graph, 4-7
- resolution vs bandwidth (in meters)
 - graph, 4-10
- resume the program, 1-11
- return loss, 2-3, 3-13, 3-14
- running the program, 1-5
- running the software, 1-3-6

S save ASCII trace data, 3-23

- SAVE RECALL**, 3-23
- save setup/data, 3-23
- saving data to disk, 3-18
- SCALE**, 3-24
- scale/div, 3-24
- setup
 - default, 1-8
 - equipment, 1-11, 2-7
 - guided, 1-9, 2-5
- setup diagram, 1-11, 2-7
- Setup Diagram**, 1-11
- setups
 - how to recall, 3-23

- how to save, 3-23
- sidelobes, 3-27
- single, 3-26
- single sweep, 3-26
- softkey convention, vi
- softkeys, 3-2-29
- software
 - to exit, 1-12
 - to pause, 1-11
 - to run, 1-3
- software copying, 5-3
- software defaults, 1-8
- software disk, 1-3
- software license agreement, 5-2
- software product license agreement, 5-2-5
- software programs, 1-3
- software updates and upgrades, 5-5
- source match calibration, 3-10
- span
 - frequency, 3-17
- split screen, 3-15
- spreadsheet data, 3-23
- standing wave ratio, 2-3, 3-13, 3-14
- start distance, 3-21, 3-24
- stop distance, 3-21, 3-25
- stop sweep, 3-26
- storing correction constants, A-4
- SWEEP**, 3-26
- sweep trigger menu, 3-26
- SWR, 2-3, 3-13, 3-14
- SYSTEM OPTIONS**, 3-27

T test limit line, 3-28

- example, 2-10
- theory, 2-3
- time/date display, 3-29
- title
 - how to change, 3-29
- title and clock off, 3-29
- title and clock on, 3-29
- title display, 3-29
- tracepoints
 - selecting, 3-21
- trigger
 - single, 3-26
- triggering, 3-26
- turning markers off, 3-20
- typical cable loss table, B-2

typical velocity factor table, B-2

U using markers, 3-19
example, 2-9

V velocity factor, 3-10
definition, 3-10
velocity factor table, B-2

W warranty, 5-7
limited, 5-6
window, 3-27
maximum, 3-28
medium, 3-28
minimum, 3-28
windowing, 3-27, 4-3