

**HP 9121D/S and  
9122D/S Disc Drives  
Operator's Manual**



Manual Part No.  
09122-90000

Printed in U.S.A.  
April 1, 1985

## Warranty and Service

Hewlett-Packard products are warranted against defects in materials and workmanship. For Hewlett-Packard products sold in the U.S.A. and Canada, this warranty applies for ninety (90) days from date of installation.\* Hewlett-Packard will, at its option, repair or replace equipment which proves to be defective during the warranty period. A copy of the complete warranty statement is available upon request.

HP offers complete service and maintenance worldwide. Maintenance agreements are available for all HP peripheral products. Advantages of these agreements to the customer include a fixed annual cost, individualized cost-effective contracts, and a choice of response time. Current U.S.A. rates can be determined by contacting your local HP Sales Office.

The selection and use of media, supplies, and consumables is the customer's responsibility. Hewlett-Packard reserves the right to exclude from the warranty or service agreement any repairs for damage to HP products which HP reasonably determines or believes were caused by use of non-HP media or cleaning supplies. Hewlett-Packard will, upon request, repair such damage on a time and material basis.

Repairs necessitated by misuse of the equipment, or by hardware, software, or interfacing not provided by Hewlett-Packard are not covered by this warranty.

NO OTHER WARRANTY IS EXPRESSED OR IMPLIED, INCLUDING, BUT NOT LIMITED TO, THE IMPLIED WARRANTIES OR MERCHANTABILITY AND FITNESS FOR A PARTICULAR PURPOSE. HEWLETT-PACKARD SHALL NOT BE LIABLE FOR CONSEQUENTIAL DAMAGES.

\* For other countries, contact your local Sales and Support Office to determine warranty terms.

**Federal Communications Commission  
Radio Frequency Interference Statement  
USA Only**

This equipment generates and uses radio frequency energy and if not installed and used properly, that is, in strict accordance with the manufacturer's instructions, may cause interference to radio and television reception. It has been type tested and found to comply with the limits for a Class B computing device in accordance with the specifications in Subpart J of Part 15 of FCC rules, which are designed to provide reasonable protection against such interference in a residential installation. However, there is no guarantee that interference will not occur in a particular installation. If this equipment does cause interference to radio or television reception, which can be determined by turning the equipment off and on, the user is encouraged to try to correct the interference by one or more of the following measures.

- reorient the receiving antenna
- relocate the computer with respect to the receiver
- move the computer away from the receiver
- plug the computer into a different outlet so that computer and receiver are on different branch circuits

If necessary, the user should consult the dealer or an experienced radio/television technician for additional suggestions. The user may find the following booklet prepared by the Federal Communications Commission helpful:

"How to Identify and Resolve Radio-TV  
Interference Problems".

This booklet is available from the U.S. Government Printing Office, Washington, DC 20402, Stock No. 004-000-00345-4.

---

# Table of Contents

---

---

---

---

Deutsch

Espanol

Francais

Italiano

---

## Part I: Installation Guide

---

About this Manual . . . . .	1
A Look at Your Disc Drive . . . . .	2
A Look at the Equipment Supplied . . . . .	3
Installation . . . . .	3
Handling the Flexible Disc . . . . .	7
Single-Sided versus Double-Sided Discs . . . . .	9
Write Protect Tab . . . . .	10
Media Monitor . . . . .	12
Using Your Disc Drive . . . . .	13

---

## Part II: Reference Section

---

What is an HP 9121/9122 Disc Drive? . . . . .	II-1
---	------

---

## Chapter 1: Getting Set-up

---

Step 1: Unpacking and Checking the Equipment Supplied . . .	1-1
Step 2: A Look at Your Disc Drive . . . . .	1-2
Step 3: Setting Up . . . . .	1-3
Step 4: Try It! . . . . .	1-10

---

## Chapter 2: Using Your Flexible Disc

---

What is a Flexible Disc . . . . .	2-1
A Look at the Flexible Disc . . . . .	2-2
Single-Sided and Double-Sided Discs . . . . .	2-3
Loading the Flexible Disc . . . . .	2-3
Labeling the Flexible Disc . . . . .	2-4
What is the Life Expectancy of a Flexible Disc . . . . .	2-5

---

## Chapter 3: Using Your Disc Drive with Your Computer

---

---

## Chapter 4: Caring for Your Disc Drive

---

Caring for the Case . . . . .	4-1
Warranty . . . . .	4-2
Maintenance . . . . .	4-2
What If Something Goes Wrong . . . . .	4-2
How to Order Supplies . . . . .	4-4

---

## Appendix I: Technical Reference Section

---

---

## Appendix II: Glossary

---

---

## Index

---

---

## Worldwide Sales Offices

---

# A Look at Your Disc Drive

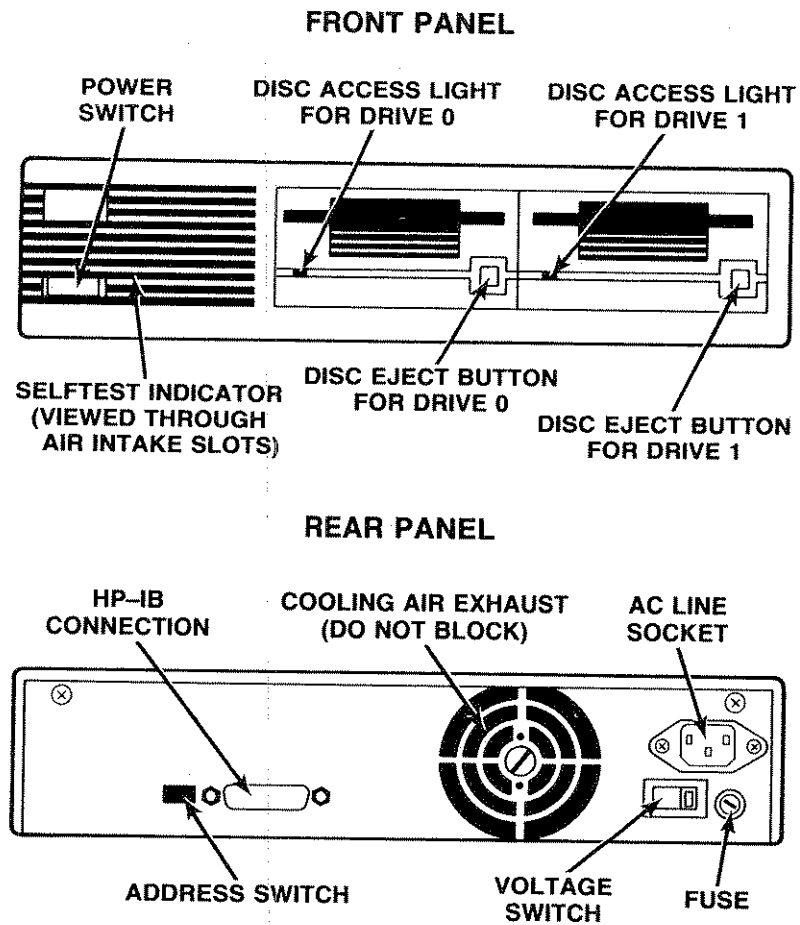

Figure 1: Front and Rear Panels of the HP 9121/9122

- Look at the parts of your disc drive illustrated in Figure 1.
- In particular, locate the power switch, fuse, voltage switch, address switch, HP-IB connection and the AC line socket.

# A Look at the Equipment Supplied

The following equipment is supplied with each HP 9121/9122 disc drive:

- Power cable
- Operator's manual

## Installation

### Setting the Voltage

---

#### WARNING

Always turn off the disc drive before changing the voltage setting in order to avoid damage to the disc drive.

---

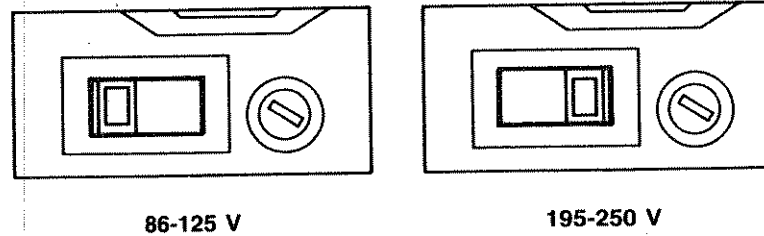

Figure 2: Voltage Switch Settings

- Find the red voltage switch on the rear panel of your disc drive.
- Make sure the voltage switch is set correctly for your local power.
- If necessary, use a screwdriver to push the voltage switch sideways until the switch displays the proper setting.

## Changing the Fuse

### WARNING

BECAUSE OF A POTENTIAL SHOCK HAZARD, ALWAYS UNPLUG THE POWER CORD IF YOU NEED TO CHANGE A FUSE. Place the fuse into the fuse-holder and then into the unit.

Voltage Setting	Voltage Range	Required Fuse
115V	86-125 VAC	1.0 Amp 250 VAC
230V	195-250 VAC	0.5 Amp 250 VAC

Figure 3: Fuses

- The fuse in your disc drive should correspond to the voltage setting.
- Make sure you have the correct fuse for the voltage in your area.

### Connecting the HP-IB Cable

- Turn off your disc drive.
- Plug one end of the HP-IB cable into the HP-IB socket of your disc drive.
- Plug the other end of the HP-IB cable into the HP-IB socket of your computer.
- Figure 4 illustrates the appearance of the HP-IB cable with an HP Touchscreen computer. If you have a different computer, the HP-IB connection on your computer may be in a different position.



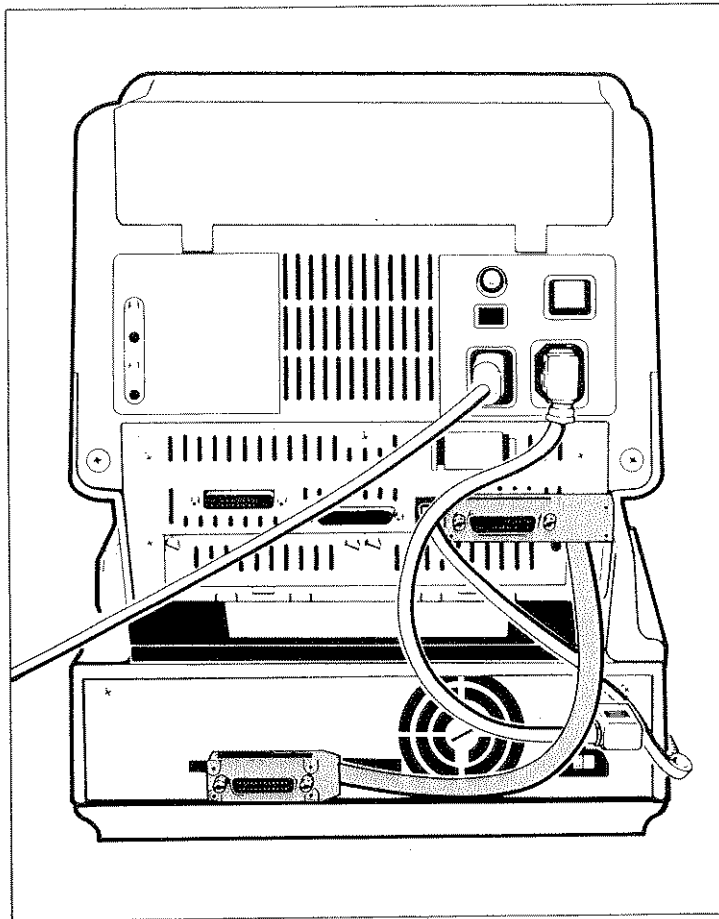

Figure 4: HP-IB cable connecting your computer and disc drive.

## Setting the Address

You have a telephone number that is different from your neighbor's telephone number. Your telephone number allows others to call you when they have a message for you or when they need information from you. Similarly, each peripheral device on a bus needs a unique telephone number so that the computer can "call" the peripheral to get or give information. On the bus, this unique number is called an address.

Address	Position of 4 small switches			
	Left	Middle Left	Middle Right	Right
0	Up	Down	Down	Down
1	Up	Down	Down	Up
2	UP	Down	UP	Down
3	Up	Down	Up	Up
4	Up	UP	Down	Down
5	Up	Up	Down	Up
6	Up	Up	Up	Down
7	Up	Up	Up	Up

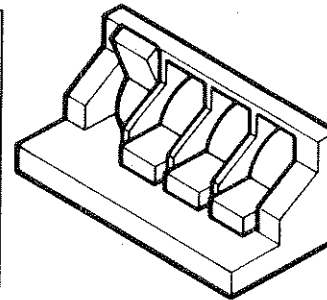

Figure 5: Address Switch Setting

- Each peripheral device must have a unique address.
- Hewlett-Packard sets your disc drive address at 0 (illustrated in Figure 5).
- If you have only one disc drive, one plotter, and one printer connected to your computer, you should not need to change the address.
- If you need to change the address:
  - Turn off the disc drive
  - Set the four small switches of the address switch to one of the addresses illustrated in Figure 5.

## Connecting the Power Cord

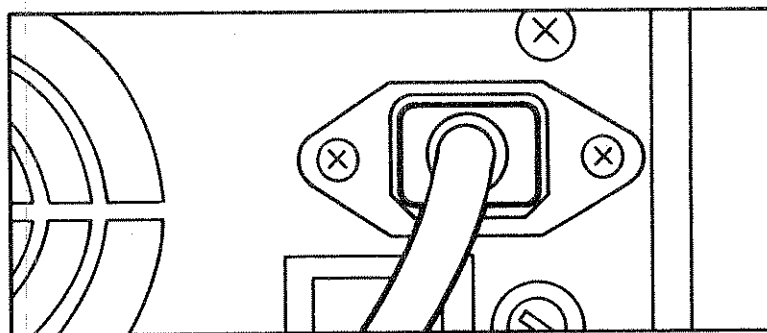
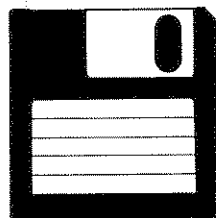

Figure 6: Power Cord Connection

- Turn off your disc drive.
- Connect the power cord to the socket labelled "AC line" on the rear panel.
- Plug the power cord into the wall socket.

## Handling the Flexible Disc



DO

Make sure the shutter is closed when the disc is not in use.

WHY?

Protects the disc from dust, fingerprints, and scratches.



DO

Use the disc in a clean environment.

WHY?

Minimizes the risk of dust or dirt particles scratching the disc.

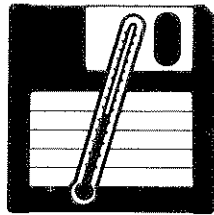

DO

Keep discs stored upright in a cool, dry place.

WHY?

Prevents moisture and heat damage.

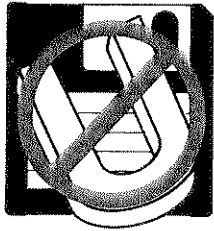

DO

Avoid magnetic fields, such as appliances with motors.

WHY?

Prevents magnetically erasing the data on your discs.

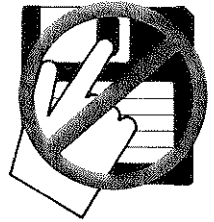

DON'T

Touch the surface of the disc.

WHY?

Particle contamination can scratch the disc or cause the disc to wear out sooner than normal.



DON'T

Try to clean the disc.

WHY?

The plastic jacket contains a mechanism for cleaning the disc surface. Other cleaning methods may damage the disc.

## Single-Sided versus Double-Sided Discs

The HP 9122 records data on both sides of a disc. **For daily use, we recommend gray double-sided Hewlett-Packard discs with an HP 9122.**

The HP 9121 records data on only one side of a disc. **For daily use, we recommend blue single-sided Hewlett-Packard discs with an HP 9121.**

Table I details this recommended usage of single-sided and double-sided discs. Words used in the table are defined as follows:

- "Single-sided format" means that data is recorded on only one side of your disc.
- "Double-sided format" means that data is recorded on both sides of your disc.
- "Exchange only" means that the media should be used only for copying data and programs and should not be used on a daily basis.
- "OK" means that the media may be used on a daily basis.
- "NO" means that the media cannot be used.

---

### CAUTION

Disc drive performance and reliability are dependent on the type of media used. Disc drive specifications can be assured only when using HP media. The use of improper media can result in premature disc failure or damage to the disc drive.

On some disc products, HP may qualify other non-HP media. When tested, this media met HP specifications. However, HP does not warrant or support this media and cannot control changes in its specifications or quality. The selection and use of such products is the customer's responsibility. HP reserves the right to exclude from warranty and maintenance agreement coverage any repairs which HP reasonably determines or believes were caused by the use of media not provided by HP. HP will, upon request, provide such repairs on a time and material basis.

---

	If you have an HP 9121	If you have an HP 9122 <sup>1</sup>
Single-sided HP media	OK	exchange only
Double-sided HP media in single-sided format	OK	OK
Double-sided HP media in double-sided format	NO	OK
HP software – single-sided or double-sided media <sup>2</sup>	OK	OK
<sup>1</sup> You can only use discs with auto-shutters in the HP 9122. <sup>2</sup> Software provided by Hewlett-Packard has been tailored for the computer/disc system on which the software will be used.		

**Table I: Recommended usage of single-sided versus double-sided discs.**

## Write Protect Tab

- Write protecting ensures that the disc drive cannot write over or delete information on the disc.
- Write protect discs that contain valuable programs and data.
- Follow Figure 6 if you wish to write protect a double-sided disc, and Figure 7 if you wish to write protect a single-sided disc.

If you want to write protect a double-sided disc for the HP 9122:

- Place the tip of a pen in the small hole at the top of the write-protect tab.
- Slide the tab downward until it locks into place.
- If you no longer wish to write protect the disc, slide the tab up.

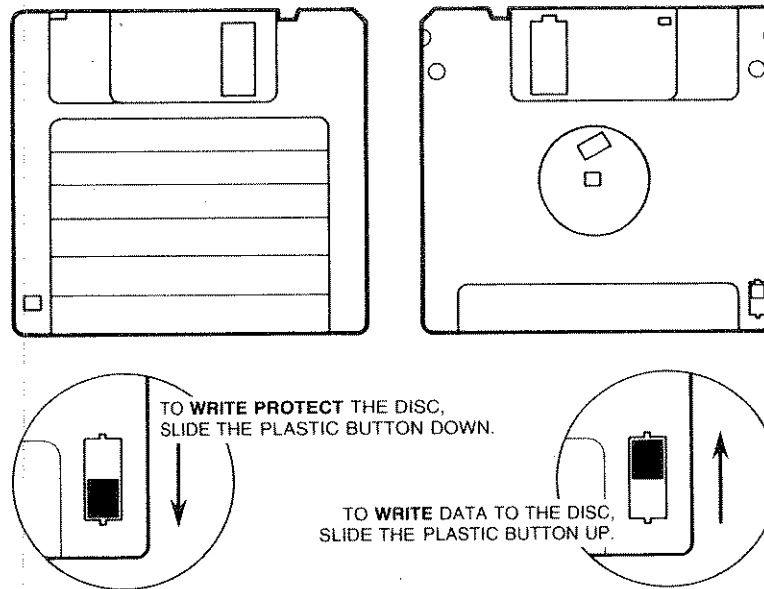

Figure 6: Write Protect Tab on the HP 9122

If you want to write protect a single-sided disc for the HP 9121:

- Use a screwdriver or the tip of a pen to gently lift up and break off the tab.
- Turn the tab sideways and position it next to the groove.
- Press firmly until the tab snaps into place.
- If you no longer wish to write protect the disc, slide the tab up away from the groove.

If you have a disc with the write protect tab missing, the disc is write protected. If you want to override the write protect, you can place tape over the tab opening in order to allow you to write data on the disc.

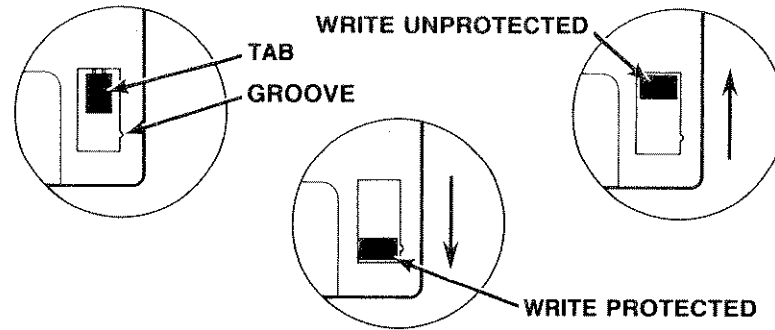

Figure 7: Write Protect Tab on the HP 9121

## Media Monitor

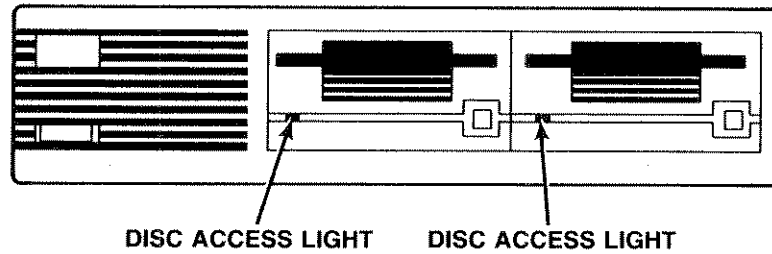

Figure 8: Position of the disc access light on the front panel of your disc drive.

- Through a feature called the Media Monitor, your disc drive monitors the cumulative use of a disc.
- When usage is approaching a level at which there is any risk of loss of data through normal disc wear, the disc access light blinks and a clicking sound is heard when the computer is NOT using the disc.
- At your earliest convenience, copy the disc you are using and begin using the copy. Discard the original disc.



## Using Your Disc Drive

- You are now ready to use your disc drive.
- For information on how to configure your disc drive with your computer, refer to the configuration section of your computer manual.
- For information on formatting discs and making backup copies of discs, refer to the disc drive or mass storage section of your computer manual.
- Information on configuration, formatting, and backup may also be found in Part II, Chapter 3 of this manual.

---

## Part 1

---

---

# INSTALLATION GUIDE

---

### About This Manual

This manual has two parts: an installation guide and a reference section. Part I is the installation guide. Following the pictures and text in Part I allows you to connect your disc drive to your computer and learn to use your flexible discs. This installation guide is presented in five languages.

The second part of the manual is a reference section. This section elaborates on the contents of the installation guide, as well as providing information on what to do if something goes wrong. This material is presented in English.

The pages of this manual are perforated between the binding and the three-hole drill. Therefore, you can easily remove and discard the portions of the manual that you do not need. If you wish, you may also remove the portions of the manual that you wish to keep and insert those pages into a three-hole binder, such as your computer manual binder.

You can most easily remove the perforated pages by first folding the pages along the perforation. Start your tear at the top or bottom edge and then remove the page by tearing in a smooth, easy motion.

---

## Abschnitt 1

---

---

# INSTALLATIONSANLEITUNG

---

### Einführung

Das Handbuch ist in zwei Abschnitte eingeteilt: die Installationsanleitung und die Bedienungsanleitung. Abbildungen und Text in Abschnitt 1 beschreiben den Anschluß des Plattenspeichergeräts an den Computer und die Benutzung der Disketten. Die Installationsanleitung liegt in fünf Sprachen vor.

Der zweite Abschnitt entspricht einem Nachschlagehandbuch. Dieser Abschnitt enthält eine ausführliche Beschreibung der Installationsanleitung; außerdem werden Ausnahmefälle und Fehlerzustände beschrieben. Diese Beschreibung liegt in englischer Sprache vor.

Die einzelnen Seiten des Handbuchs sind zwischen dem Einband und der Dreierlochung perforiert. Dadurch lassen sich einzelne Teile des Handbuchs, die nicht benötigt werden, einfach entfernen. Natürlich können auch häufig gebrauchte Seiten herausgenommen werden und in einen Ordner - wie zum Beispiel das Computerhandbuch - geheftet werden.

Die perforierten Seiten sind am einfachsten zu entfernen, wenn Sie sie zuerst entlang der Perforation falzen. Beginnen Sie die Seiten von der oberen oder unteren Kante abzureißen. Reißen Sie die Seiten langsam und gleichmäßig ab.



Abbildung 1: Vorder- und Rückseite des HP 9121/9122 Geräts

- Vergleichen Sie Ihr Plattenspeichergerät mit Abbildung 1
- Beachten Sie besonders den Stromschalter, den Spannungsschalter, den Adressschalter, den HP-IB Anschluß und den Wechselstromstecker.

# Sehen Sie sich das Zubehör genau an

Für jedes HP 9121/9122 Plattenspeichergerät erhalten Sie folgendes Zubehör:

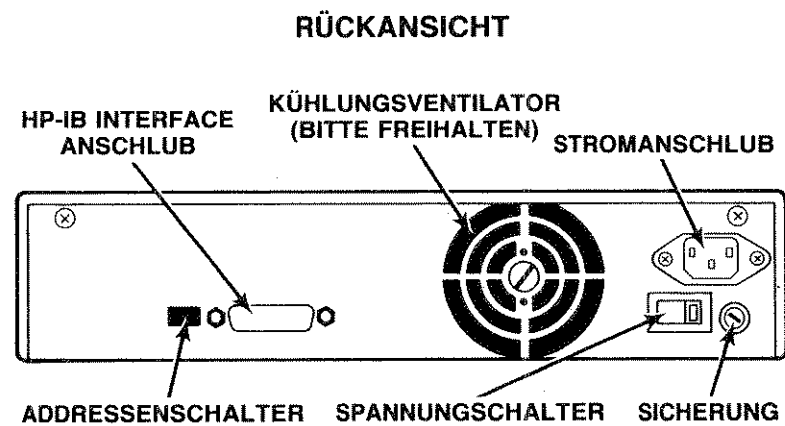
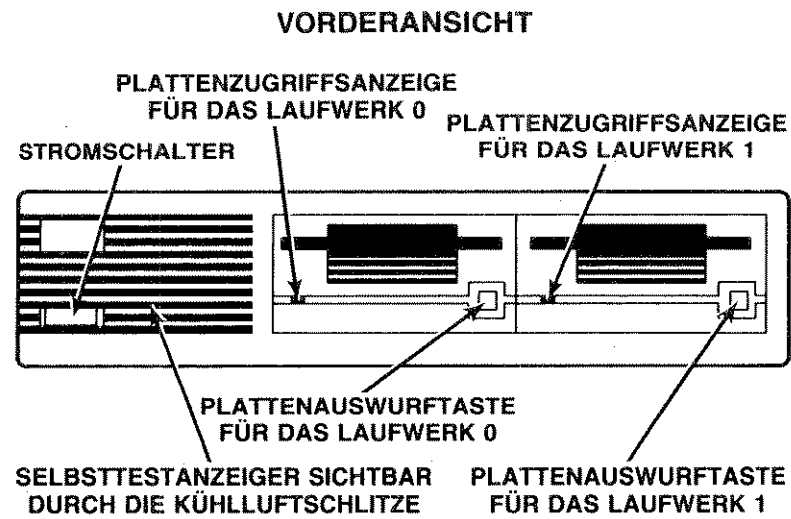
- Anschlußkabel
- Bedienungsanleitung

## Installation

### Einstellung der Netzspannung



Abbildung 2: Einstellungen des Netzspannungsschalters

---

#### VORSICHT

Damit kein Schaden am Gerät entsteht, schalten Sie das Gerät ab, bevor Sie die Netzspannungseinstellung ändern.

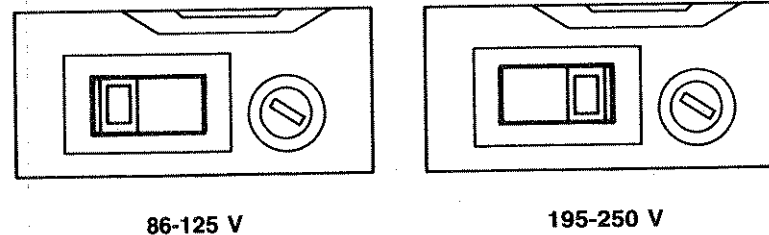
---

- Suchen Sie den roten Netzspannungsschalter auf der Rückseite des Geräts.
- Prüfen Sie nach, ob die Netzspannungseinstellung der vorhandenen Stromversorgung entspricht.
- Notfalls verwenden Sie einen Schraubenzieher und schieben den Schalter seitwärts, um die richtige Einstellung zu erhalten.

## Austausch der Sicherung

### VORSICHT

Bevor Sie die Sicherung austauschen, ziehen Sie zuerst das Stromversorgungskabel aus der Steckdose, um einen eventuellen Schock zu vermeiden. Setzen Sie die Sicherung zuerst in die Halterung und dann in den Sicherungskasten ein.

Spannungseinstellung	Spannungsbereich	Vorgeschriebene Sicherung
115V	86-125 VAC	1.0 Amp 250 VAC
230V	195-250 VAC	0.5 Amp 250 VAC

Abbildung 3: Sicherungen

- Die Sicherung im Plattenlaufwerk muß mit der Spannungseinstellung übereinstimmen.
- Benutzen Sie unbedingt eine Sicherung, die mit der Spannung übereinstimmt.

### Anschluß des HP-IB Kabels

- Schalten Sie das Plattenspeichergerät aus.
- Stecken Sie einen Anschlußteil des HP-IB Kabels in die entsprechende Buchse des Plattenspeichergeräts.
- Stecken Sie den anderen Anschlußteil des HP-IB Kabels in die entsprechende Buchse des Computers.
- Abbildung 4 zeigt die Verbindung des HP-IB Kabels mit einem HP 150 Computer. Sollten Sie einen anderen Computer haben, befindet sich der Anschlußstecker nicht unbedingt an derselben Stelle.

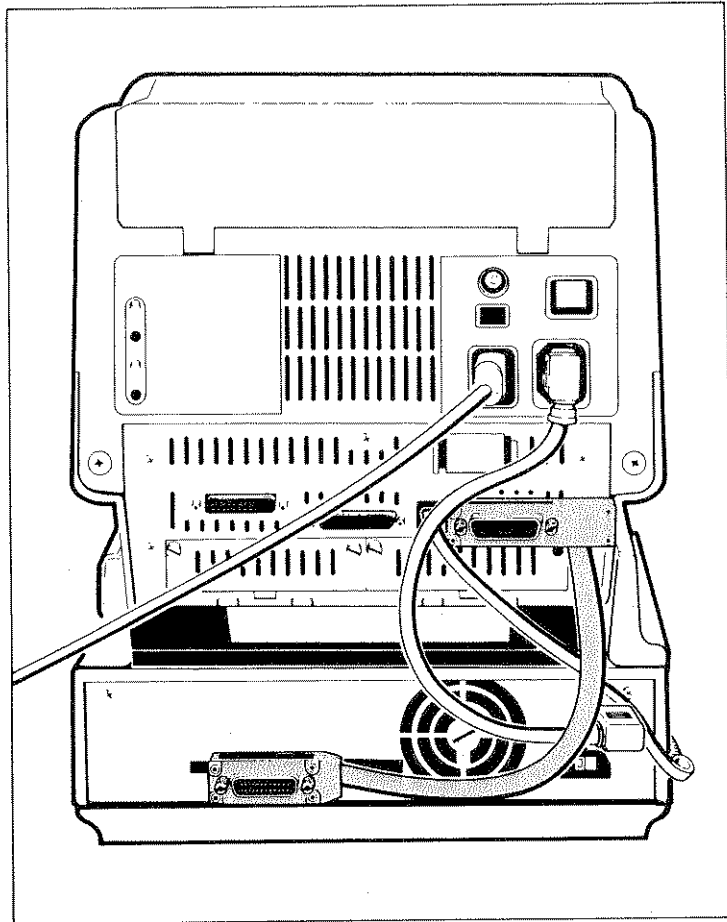

**Abbildung 4: Anschluß des HP-IB Kabels an Computer und  
Plattenspeichergerät.**

## Einstellen des Adresschalters

Sie und Ihr Nachbar besitzen verschiedene Telefonnummern. Die Telefonnummer wird dazu benutzt, um Mitteilungen zu machen oder um Auskunft zu fragen. Vergleichsweise besitzt jedes Peripheriegerät, das an eine Sammelschiene angeschlossen ist, eine Telefonnummer, die der Computer benutzt, um Information zu übertragen. Die Telefonnummer für eine Sammelschiene wird Adresse genannt.

Adresse	Stellung der 4 kleinen Schalter			
	Links	Zweiter von links	Zweiter von rechts	Rechts
0	Unten	Unten	Unten	Unten
1	Unten	Unten	Unten	Oben
2	Unten	Unten	Oben	Unten
3	Unten	Unten	Oben	Oben
4	Unten	Oben	Unten	Unten
5	Unten	Oben	Unten	Oben
6	Unten	Oben	Oben	Unten
7	Unten	Oben	Oben	Oben



Abbildung 5: Einstellung der Adresschalter

- Jedes Peripheriegerät benötigt eine eindeutige Adresse
- Vom Hersteller wird die Geräteadresse auf 0 eingestellt (siehe Abbildung 5).
- Wenn Sie nur ein Plattenspeichergerät, einen Drucker und einen Plotter an den Computer anschließen, kann die Adresseneinstellung unverändert beibehalten werden.
- Muß jedoch die Adresseneinstellung geändert werden
  - Schalten Sie das Gerät ab
  - Wählen Sie eine der in Abbildung 5 abgebildeten Schalterstellungen aus



## Anschluß des Stromkabels

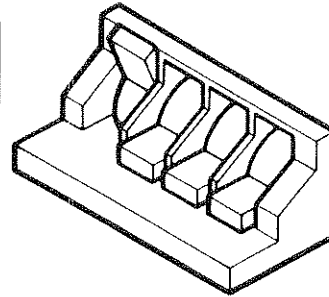

Abbildung 6: Anschluß des Stromkabels

- Schalten Sie das Gerät aus
- Stecken Sie das Stromkabel in die Buchse mit der Beschriftung "Wechselstrom" auf der Rückseite des Geräts
- Stecken Sie das Kabel in eine Steckdose.

## Verwendung und Behandlung der Disketten

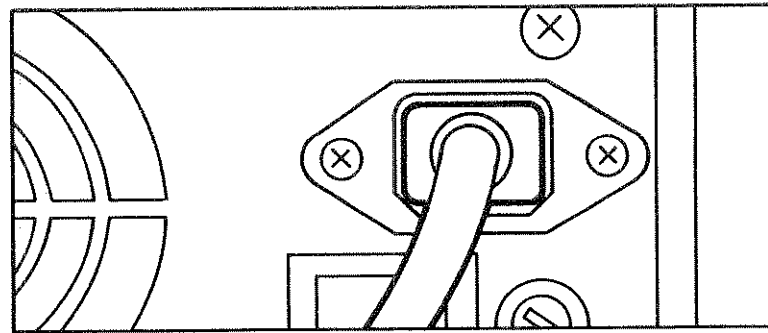
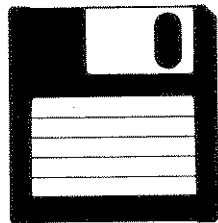

**Zu Beachten** Vergessen Sie nicht, nach Benutzung der Diskette den Schieberverschluss in die Verschlussstellung zu schieben.

**Warum?** Dadurch schützen Sie die Diskette vor Staub, Fingerabdrücken und Kratzern.



Zu Beachten Benutzen Sie die Diskette in einer sauberen Umgebung.

Warum? Dadurch ist die Wahrscheinlichkeit, daß Schmutz und Staubteilchen die Diskette verkratzen, geringer.

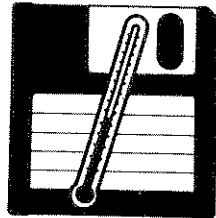

Zu Beachten Lagern Sie die Disketten aufrecht und bei kühler Temperatur und geringer Luftfeuchtigkeit.

Warum? Dadurch werden durch Feuchtigkeit und Hitze verursachte Schäden verhindert.



Zu beachten Vermeiden Sie Magnetfelder, wie zum Beispiel Geräte mit Motorbetrieb.

Warum? Dadurch verhindern Sie, daß die gespeicherten Daten magnetisch gelöscht werden.

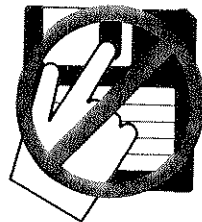

Zu Unterlassen Berühren Sie nicht die Diskettenoberfläche

Warum? Schmutzteilchen können die Diskette verkratzen oder zur frühzeitigen Abnutzung führen.



Zu Unterlassen Reinigen Sie die Diskette nicht

Warum? Die Plastikhülle besitzt eine Vorrichtung zur Reinigung der Diskettenoberfläche. Andere Reinigungsverfahren können zur Beschädigung der Diskette führen.

## Ein- und doppelseitig beschreibbare Disketten im Vergleich

Das Gerät HP 9122 zeichnet Daten auf beiden Diskettenseiten auf. Für den täglichen Gebrauch empfehlen wir die grauen doppelseitig beschreibbaren Disketten für das Gerät 9122.

Das Gerät HP 9121 zeichnet Daten auf der Diskette nur einseitig auf. Für den täglichen Gebrauch empfehlen wir die blauen einseitig beschreibbaren Disketten für das Gerät HP 9121.

Die Tabelle 1 enthält eine ausführliche Beschreibung des Gebrauchs einseitig und doppelseitig beschreibbarer Disketten. Die einzelnen Bezeichnungen haben die folgende Bedeutung:

- "Monoformat" : Daten werden auf der Diskette nur einseitig aufgezeichnet.
- "Dualformat" : Daten werden auf der Diskette beidseitig aufgezeichnet.
- "Datenaustausch" : Die Disketten sollten nur zur Zwischenspeicherung von Daten und Programmen verwendet werden und sind nicht für den täglichen Gebrauch gedacht.
- "OK" : Die Disketten können für den täglichen Gebrauch verwendet werden.
- "NO" : Die Disketten dürfen nicht verwendet werden.

	Falls Sie das Gerät HP 9121 besitzen	Falls Sie das Gerät HP 9122 besitzen <sup>1</sup>
Einseitig beschreibbare Diskette	OK	Datenaustausch
Doppelseitig beschreibbare Diskette Monoformat	OK	OK
Doppelseitig beschreibbare Diskette Dualformat	NO	OK
HP Software - doppelseitig oder einseitig <sup>2</sup>	OK	OK
<sup>1</sup> Für das Gerät HP 9122 können nur Disketten mit automatischem verschluß verwendet werden. <sup>2</sup> Von Hewlett Packard gelieferte Software wird auf den jeweiligen Computer und Plattenspeicher abgestimmt.		

**Tabelle 1: Empfehlung für die Verwendung von doppelseitig  
und einseitig beschreibbaren Disketten.**

## Schreibschutzvorrichtung

- Die Schreibschutzvorrichtung verhindert das Löschen und Überschreiben von Daten auf der Diskette.
- Disketten mit wertvollen Programmen und Daten sollten schreibgeschützt werden.
- Beachten Sie Abbildung 6 für den Schreibschutz einer doppelseitig beschreibbaren Diskette und Abbildung 7 für den Schreibschutz einer einseitig beschreibbaren Diskette. Die Diskette ist schreibgeschützt, indem Sie den roten Plastikknopf nach unten schieben.



Abbildung 6: Schreibschutzknopf des Geräts HP 9122

Eine doppelseitig beschreibbare Diskette für das Gerät HP 9122 soll schreibgeschützt werden:

- Setzen Sie eine Bleistiftspitze am oberen Ende des weißen Schreibschutzknopfes an.
- Schieben Sie den Schreibschutzknopf nach unten in die Verschlussstellung

- Soll der Schreibschutz aufgehoben werden, schieben Sie den Knopf nach oben.

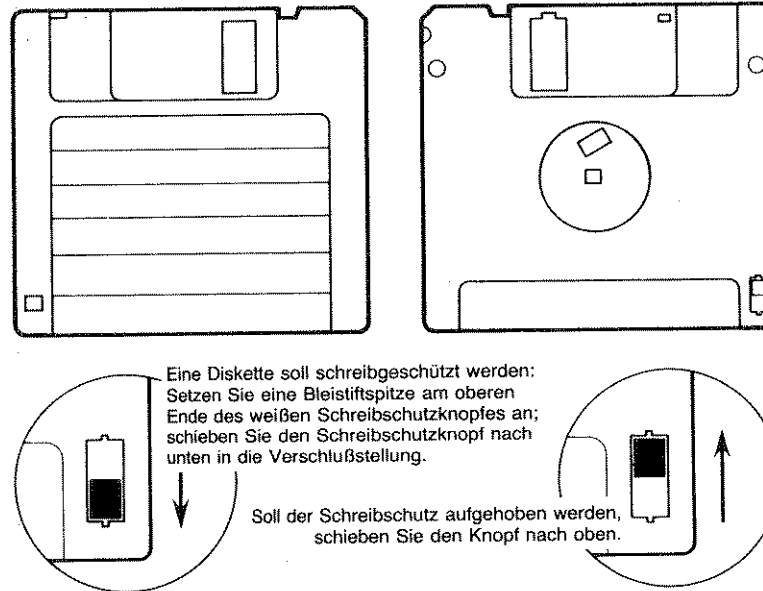

Abbildung 7: Schreibe- und Schreibschutzklappe des Geräts HP 9121

Eine einseitig beschreibbare Diskette für das Gerät HP 9121 soll schreibgeschützt werden:

- Verwenden Sie einen Schraubenzieher oder eine Bleistiftspitze, um die Schreibschutzklappe abzuheben und abzubrechen.
- Drehen Sie die Klappe um 90 Grad und setzen Sie sie neben der Kerbe ein.
- Unter Druck schnappt die Klappe ein.
- Soll der Schreibschutz aufgehoben werden, schieben Sie die Klappe nach oben weg von der Kerbe.

Sollte die Schreibschutzklappe fehlen, ist die Diskette schreibgeschützt. Soll der Schreibschutz aufgehoben werden, decken Sie die Öffnung mit einem Klebestreifen ab, damit erneut Daten auf der Diskette aufgezeichnet werden können.

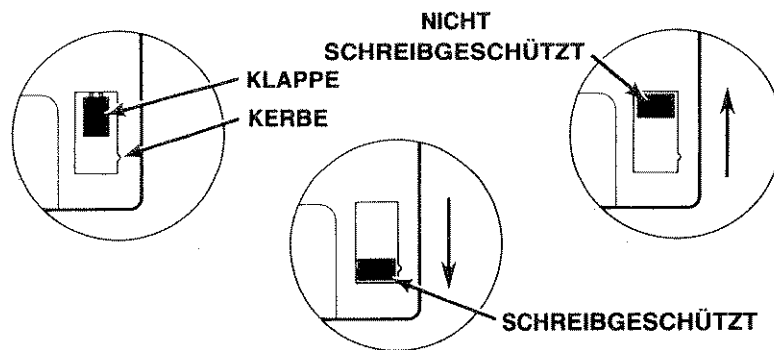
# Medienmonitor



Abbildung 8: Die Abbildung zeigt die Zugriffsanzeige auf der Vorderseite des Geräts

- Durch diese Vorrichtung zur Überprüfung der Disketten kann das Laufwerk die Gesamtdauer der Benutzung der Disketten überwachen.
- Überschreitet die Benutzung eine bestimmte Dauer, bei der die Gefahr besteht, daß die Daten auf Grund der Abnutzung verloren gehen, leuchtet die Zugriffsanzeige abwechselnd auf und ein klickendes Geräusch ist hörbar, wenn die Platte NICHT benutzt wird.
- Kopieren Sie die Daten sobald wie möglich und verwenden Sie die erzeugte Kopie. Ziehen Sie die alte Diskette aus dem Gebrauch.

## Inbetriebnahme des Plattenlaufwerks

- Das Plattenlaufwerk ist nun betriebsbereit
- Eine Anleitung, um Ihr Plattenlaufwerk entsprechend zu konfigurieren, finden Sie im Abschnitt "Konfiguration" Ihres Handbuchs.
- Eine Anleitung zur Formatierung der Disketten und Durchführung der Datensicherung finden Sie im Abschnitt über Plattenlaufwerk und Massenspeicher des Handbuchs.
- Anleitungen zur Konfiguration, Formatierung und Datensicherung finden Sie auch im Teil 2 des Abschnitts 3.

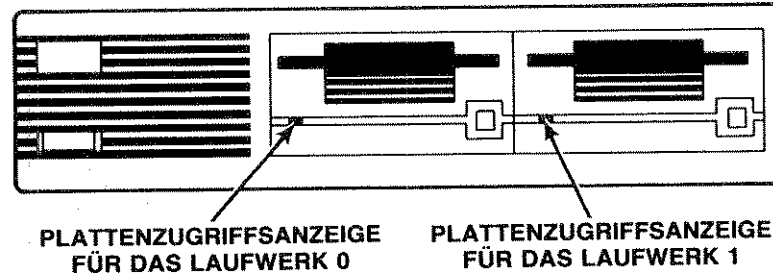
---

# Parte 1

---

---

## GUÍA DE INSTALACIÓN

---

### Observaciones Preliminares

El presente manual comprende dos partes: una guía de instalación, y una sección de referencia. La Parte I es la guía de instalación. Siguiendo las ilustraciones y el texto de la Parte I puede conectarse la unidad de disco al computador y aprender a utilizar los discos flexibles. Esta guía de instalación se presenta en cinco idiomas.

La segunda parte del manual es la sección de referencia. En esta sección se amplían detalles de la guía de instalación, y, además, se suministra información sobre como proceder si se presenta algún contratiempo. Este material está en idioma inglés.

Las páginas de este manual están perforadas entre la encuadernación y la hilera de tres perforaciones. Por lo tanto, es fácil desprender y descartar las partes del manual que no interesen. Si así se desea, también es posible retirar las partes de interés del manual e insertar esas hojas en un encuadernador de tres argollas, tal como el del manual del computador. La manera más fácil de separar las páginas perforadas es plegándolas primero por la línea de perforaciones. Luego se las desprende comenzando por el borde superior o el inferior, con un movimiento suave y continuo.



# Vista general de la unidad de disco



Figura 1: Frente y panel posterior de la HP 9121/9122

- Obsérvense las partes de la unidad de disco ilustradas en la figura 1.
- En particular, ubíquese el interruptor de alimentación, el fusible, el selector de voltaje, el selector de dirección, la conexión HP-IB, y el zócalo de conexión de línea de CA.

# Examínese el equipo suministrado

Con cada unidad de disco HP 9121/9122 se suministran los siguientes elementos:

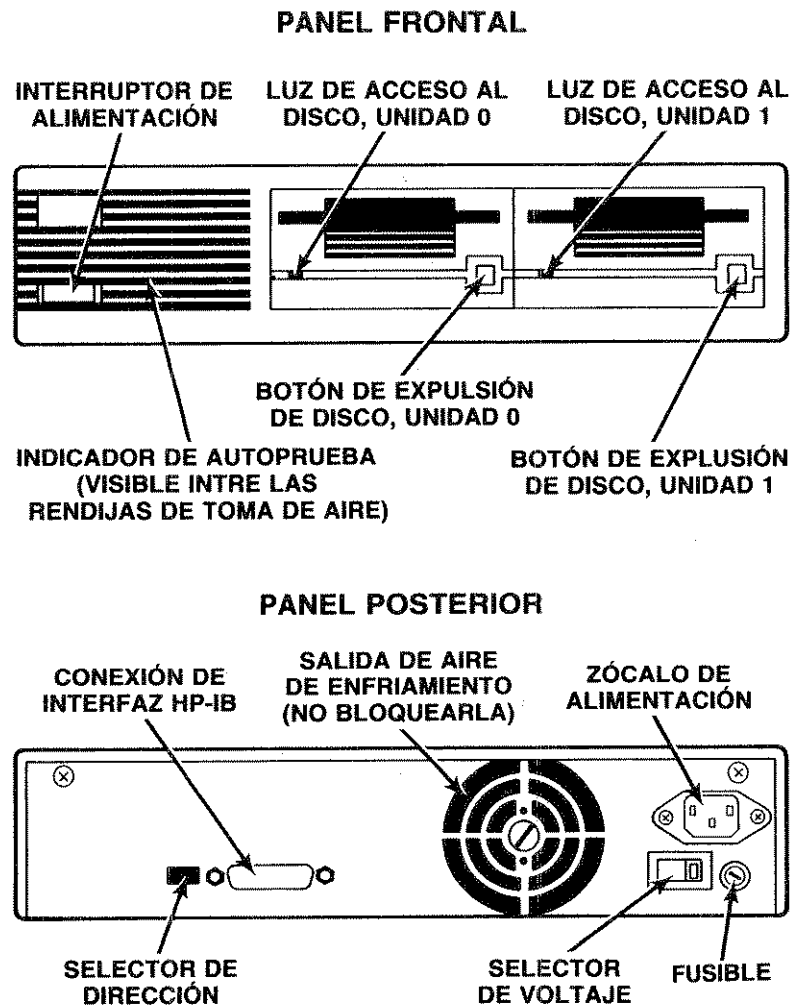
- Cordón de alimentación
- Manual del operador

## Instalación

### Ajuste de voltaje



Figura 2: Ajustes del selector de voltaje

#### ADVERTENCIA

Para evitar dañar la unidad de disco, la misma debe apagarse siempre antes de cambiar el ajuste del selector de voltaje.

- Localícese el selector de voltaje (color rojo) en el panel posterior de la unidad de disco.
- Compruébese que el selector de voltaje está ajustado correctamente, de acuerdo con la red de energía local.
- Si es necesario, desplácese el selector lateralmente, empujándolo con un destornillador, de modo que quede visible la selección correcta de voltaje.

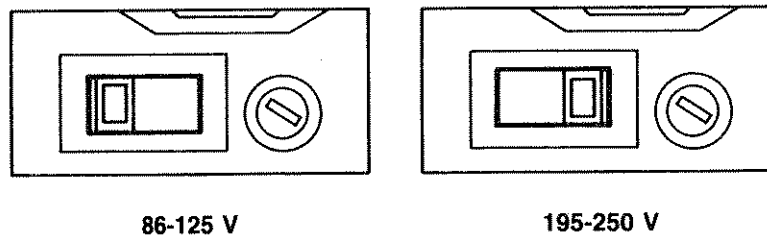
## Reemplazo del fusible

### ADVERTENCIA

DEBIDO AL PELIGRO POTENCIAL DE CHOQUE ELECTRICO, DEENCHUFESE SIEMPRE EL CORDON DE ALIMENTACION ANTES DE REEMPLAZAR UN FUSIBLE. Colóquese el fusible en el portafusible y luego colóquese éste en la unidad.

Ajuste de voltaje	Gama de voltaje	Fusible requerido
115 V	86-125 Vca	1,0 A; 250 Vca
230 V	195-250 Vca	0,5 A; 250 Vca

Figura 3: Fusibles

- El fusible que se encuentre en la unidad de disco debe corresponder al ajuste de voltaje.
- Compruébese que el fusible colocado en la unidad es el que corresponde al voltaje de la red de energía eléctrica local.

### Conexión del cable HP-IB

- Apáguese la unidad de disco.
- Enchúfese una extremidad del cable HP-IB en el zócalo HP-IB de la unidad de disco.
- Enchúfese la otra extremidad del mismo cable en el zócalo HP-IB del computador.
- La Figura 4 ilustra el aspecto del cable HP-IB con un computador HP150. Si el computador es diferente, su conector puede estar en una posición distinta.



Figura 4: Cable HP-IB para la interconexión del computador y la unidad de disco.

## Selección de dirección

Cada abonado al servicio telefónico tiene un número de línea diferente al de los demás abonados del vecindario. Esto permite que un abonado se comunique con otro cuando desea transmitirle o recibir de él alguna información. De manera semejante, todo dispositivo periférico conectado a un bus (canal de transferencia de datos) necesita tener asignado un número exclusivo, de suerte que el computador pueda "llamar" al dispositivo cuando necesite comunicarle información o recibirla del mismo. En el caso del bus, este número exclusivo se llama dirección.

Dirección	Posición de los 4 pequeños conmutadores			
	Izquierda extrema	Izquierda central	Derecha central	Derecha extrema
0	Arriba	Abajo	Abajo	Abajo
1	Arriba	Abajo	Abajo	Arriba
2	Arriba	Abajo	Arriba	Abajo
3	Arriba	Abajo	Arriba	Arriba
4	Arriba	Arriba	Abajo	Abajo
5	Arriba	Arriba	Abajo	Arriba
6	Arriba	Arriba	Arriba	Abajo
7	Arriba	Arriba	Arriba	Arriba

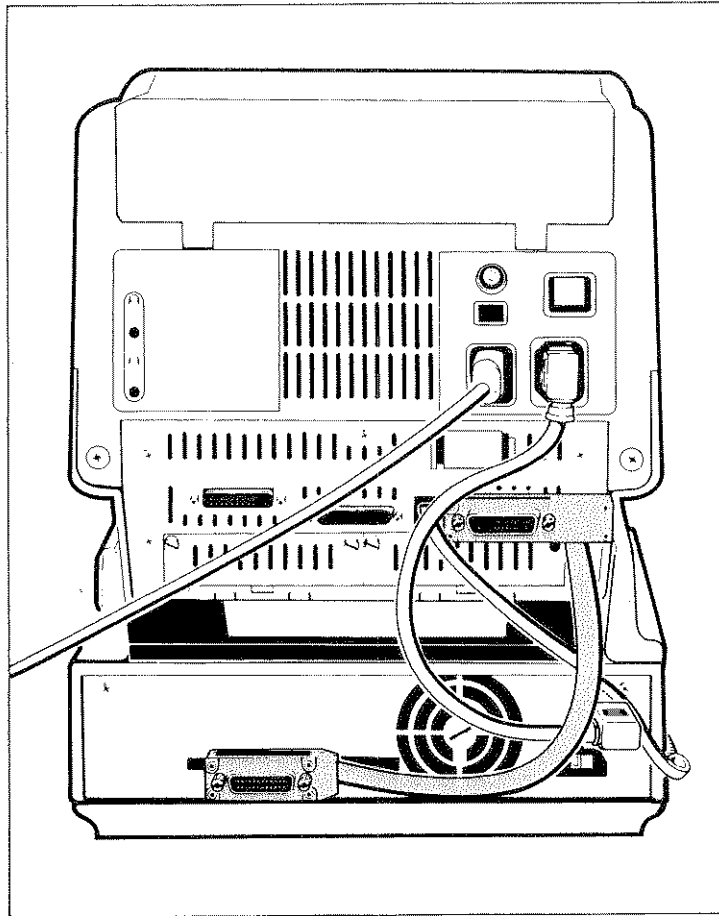

Figura 5: Disposición del selector de dirección

- Cada dispositivo periférico ha de tener una dirección exclusiva.
- Hewlett-Packard asigna a la unidad de disco la dirección 0 (ilustrada en la Figura 5).
- Si el sistema sólo comprende una unidad de disco, un trazador de gráficas y una impresora conectados al computador, no debe ser necesario cambiar la dirección.
- Si fuera necesario cambiar la dirección:
  - Apáguese la unidad de disco
  - Dispónganse los cuatro pequeños conmutadores del selector de dirección en correspondencia con una de las direcciones ilustradas en la Figura 5.

## Conexión del cordón de alimentación

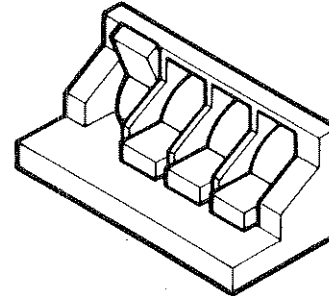

Figura 6: Conexión del cordón de alimentación

- Apáguese la unidad de disco.
- Conéctese el cordón de alimentación al zócalo rotulado "AC line" [Línea de CA] en el panel localizado en la parte posterior de la unidad.
- Enchúfese el otro extremo del cordón de alimentación en un tomacorriente de la red eléctrica.

## Manejo del disco flexible

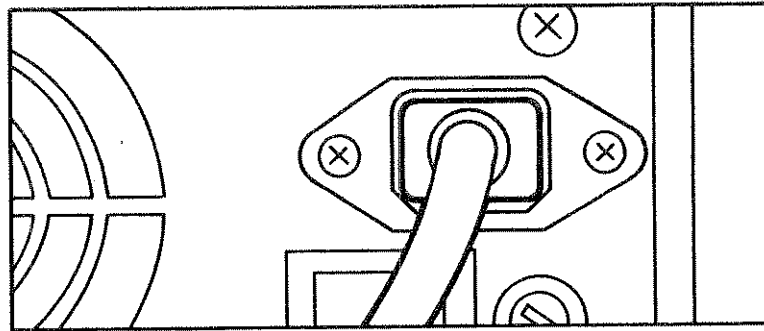
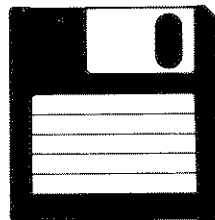

Recomendación:

Cerrar el obturador cuando el disco no esté en uso.

Razon:

Se protege al disco contra el polvo, las manchas de los dedos y los rasguños.



Recomendación:

Usar el disco en un ambiente limpio.

Razon:

Se reduce el riesgo de que el polvo o las partículas de suciedad arañen el disco.

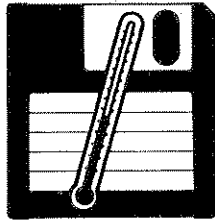

Recomendacion:

Guardar los discos en posición vertical en un lugar fresco y seco.

Razon:

Se evita que los discos sufran daño por efectos del calor y la humedad.



Recomendacion:

Evitar los campos magnéticos, como los que emanan de aparatos con motor eléctrico.

Razon:

Se impide que esos campos borren datos registrados en los discos.

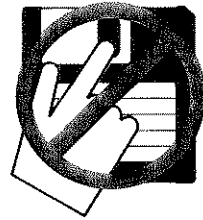

Recomendacion:

No tocar la superficie del disco.

Razon:

La contaminación con partículas extrañas puede arañar el disco o causar su desgaste prematuro.



Recomendacion:

No tratar de limpiar el disco.

Razon:

Bajo la cubierta de plástico hay un mecanismo para limpiar la superficie del disco. Cualquier otro método de limpieza puede dañar el disco.

## Discos de un solo lado y de dos lados

La HP 9122 registra datos en las dos caras del disco. Para el uso diario recomendamos los discos Hewlett-Packard grises de dos lados con un HP 9122.

La HP 9121 registra datos en una sola cara del disco. Para el uso diario recomendamos los discos Hewlett-Packard azules de un solo lado con un HP 9121.

El cuadro I presenta detalladamente el uso recomendado de los discos de registro unilateral y de registro bilateral. A continuación se definen los términos usados en el cuadro:

- "Formato de un solo lado" significa que sólo se registran datos en una cara del disco.
- "Formato de dos lados" significa que se registran datos en ambas caras del disco.
- "Sólo intercambio de datos" significa que los discos deben usarse solamente para copiar datos y programas, y que no deben usarse para el trabajo diario.
- "OK" significa que los discos pueden usarse para el trabajo diario.
- "NO" significa que no pueden usarse los discos.



Tipo de discos HP	Si se tiene una HP 9121	Si se tiene una HP 9122 <sup>1</sup>
De un solo lado	OK	Sólo intercambio de datos
De dos lados en formato de un solo lado	OK	OK
De dos lados en formato de dos lados	NO	OK
De programas; de un lado o dos lados <sup>2</sup>	OK	OK
<sup>1</sup> Solamente disco con el obturador automático pueden utilizarse en la HP 9122. <sup>2</sup> Los programas (software) suministrados por Hewlett-Packard se han adaptado especialmente al sistema de computador y unidad de disco a que los mismos se destinan.		

Cuadro I: Uso recomendado de los discos de registro unilateral y de registro bilateral.

## Tapita de protección contra escritura

- La protección contra escritura asegura que la unidad de disco no podrá escribir información en el disco o borrarla de él.
- Protéjase contra escritura discos que contengan programas o datos valiosos.
- Síganse las indicaciones de la Figura 6 si se desea proteger contra escritura un disco de registro bilateral, o las de la Figura 7 si se desea proteger contra escritura un disco de registro unilateral.



Figura 6: Tapita de protección contra escritura de la HP 9122

Si se desea proteger contra escritura un disco de registro bilateral para la HP 9122:

- Colóquese la punta de un bolígrafo en el agujerito que se encuentra en el extremo superior de la tapita de protección contra escritura.
- Deslícese la tapita (tab) hacia abajo hasta que trabe en su lugar.
- Cuando ya no se desee proteger el disco contra escritura, deslícese la tapita hacia arriba.

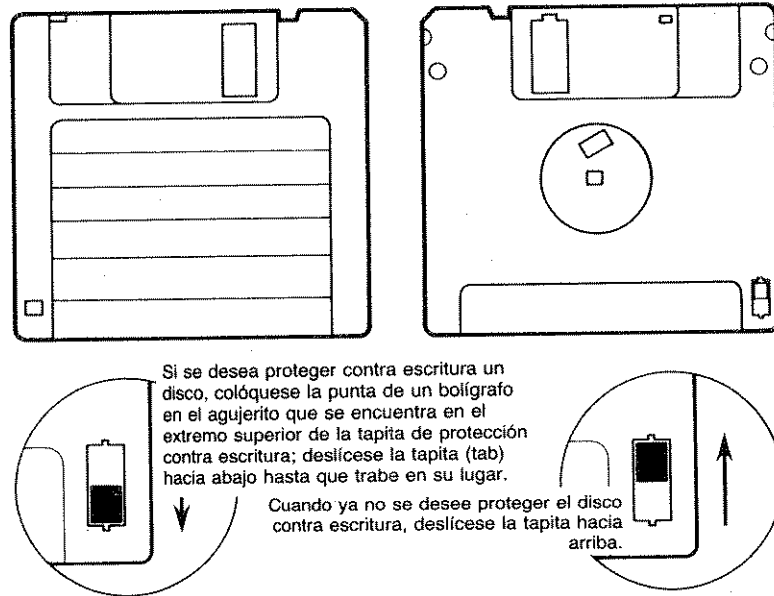
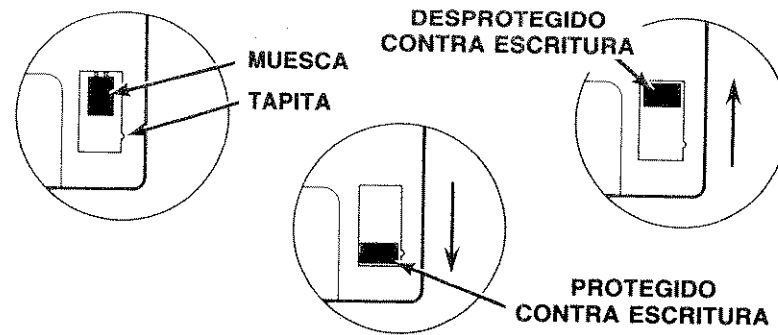

Figure 7: Tapita de protección contra escritura de la HP 9121

Si se desea proteger contra escritura un disco de registro unilateral para la HP 9121:

- Use un destornillador o la punta de un bolígrafo para, procediendo con delicadeza, levantar y desprender (por rompimiento) la tapita.
- Gírese la tapita para ponerla horizontal y colóquesela en posición adyacente a la muesca.
- Apriétese firmemente la tapita hasta que encaje en su lugar.
- Cuando ya no se desee continuar protegiendo el disco contra escritura, deslícese la tapita hacia arriba, alejándola de la muesca.

Si se tiene un disco al que le falta la tapita, ese disco está protegido contra escritura. Si se desea cancelar esa protección, para estar en condiciones de escribir datos en el disco, puede colocarse un 'parche' de cinta que cubra la abertura que queda al faltar la tapita.

---

## Parte 1

---

---

# GUIDA PER L'INSTALLAZIONE

---

### Scopo di questo manuale

Questo manuale è costituito da due parti: una guida all'installazione ed una sezione di consultazione. La Parte I è la guida all'installazione. Seguendo le illustrazioni e il testo nella Parte I potrete connettere la vostra unità disco al computer e imparare ad usare i dischi flessibili. Questa guida per l'installazione è presentata in cinque lingue.

La seconda parte del manuale è una sezione di consultazione. Questa sezione spiega il contenuto della guida per l'installazione e vi dà anche informazioni su cosa fare se c'è qualche cosa che non va. Questo materiale è presentato in inglese.

Le pagine di questo manuale sono perforate tra la copertina e la perforazione a tre fori. Potete quindi facilmente togliere ed eliminare le parti del manuale di cui non avete bisogno. Se lo desiderate, potete anche estrarre le parti del manuale che volete conservare ed inserirle in un raccoglitore a tre fori, come ad esempio il vostro raccoglitore del manuale del computer.

Potete facilmente estrarre le pagine perforate piegando prima lungo la perforazione. Cominciate dal margine superiore o da quello inferiore e staccate la pagina con un leggero e continuo strappo.

# Votre unité a disques

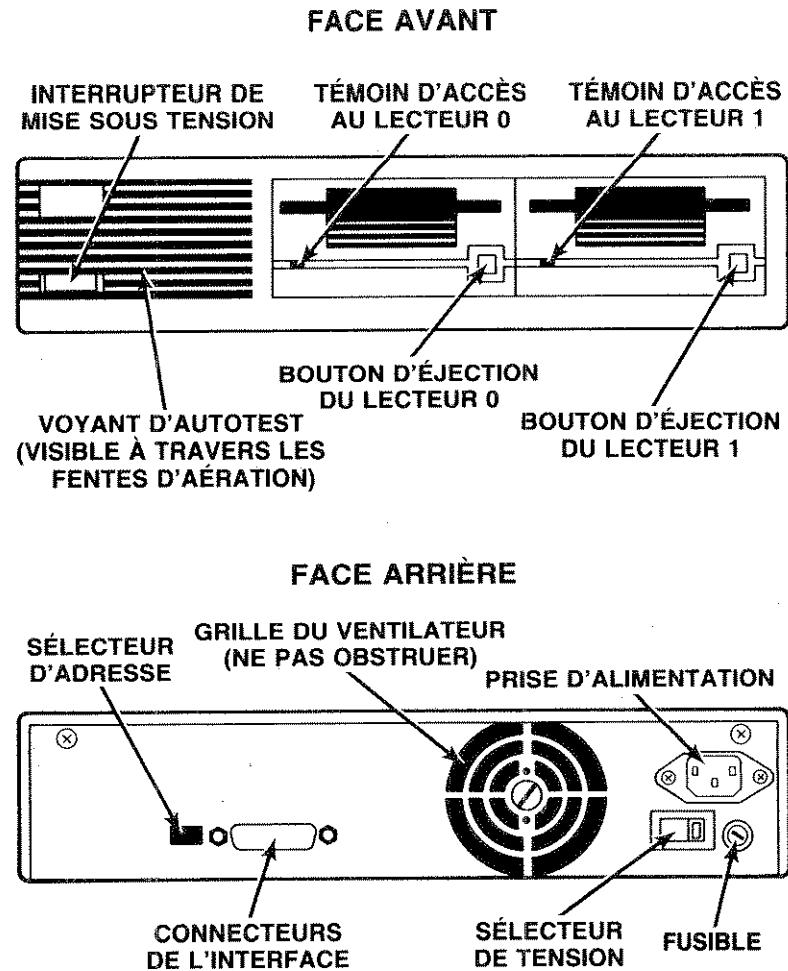

Figure 1 : L'avant et l'arrière du HP 9121/9122

- Observez les dispositifs illustrés dans la figure 1.
- Remarquez l'emplacement de l'interrupteur de mise sous tension, du fusible, du sélecteur de tension, du sélecteur d'adresse, du connecteur d'interface et de la prise de courant.

## L'équipement fourni

Les unités HP 9121/9122 sont fournies avec l'équipement suivant:

- Un câble d'alimentation
- Un manuel d'utilisation

## Installation

### Sélection de la tension d'alimentation

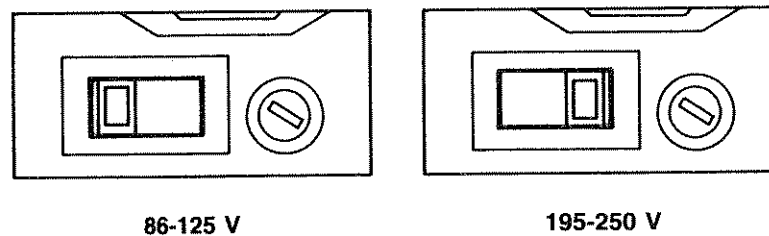

Figure 2 : Positions des sélecteurs de tension

---

#### AVERTISSEMENT

Avant de changer la tension, mettez toujours l'unité de disques hors tension, pour ne pas risquer de l'endommager.

---

- Trouvez le sélecteur de tension rouge à l'arrière de l'appareil.
- Vérifiez que la position du sélecteur correspond à celle de la tension de votre pays.
- Si c'est nécessaire, utilisez un tournevis pour déplacer le sélecteur jusqu'à ce qu'apparaisse la bonne position.

## Changement des fusibles

### AVERTISSEMENT

POUR EVITER LES COURTS CIRCUITS, RETIREZ TOUJOURS LE CORDON D'ALIMENTATION DE LA PRISE, CHAQUE FOIS QUE VOUS DEVEZ CHANGER LES FUSIBLES. Placez d'abord le fusible dans le porte-fusible, puis dans l'appareil.

Tension	Plage de tension	Fusible correspondant
115V	86-125 V	1,0 Amp 250 V
230V	195-250 V	0,5 Amp 250 V

Figure 3 : Fusibles

- Le fusible de l'unité doit correspondre à la tension.
- Vérifiez que le fusible correspond à cette tension.

## Connexion du câble

- Débranchez l'unité de disques
- Enfoncez une des extrémités du câble HP-IB dans la prise de l'unité de disques
- Enfoncez l'autre extrémité du câble HP-IB dans la prise de votre ordinateur.
- La figure 4 montre comment se place le câble HP-IB dans l'ordinateur HP 150. Si votre ordinateur est différent, la connexion HP-IB peut être différente.

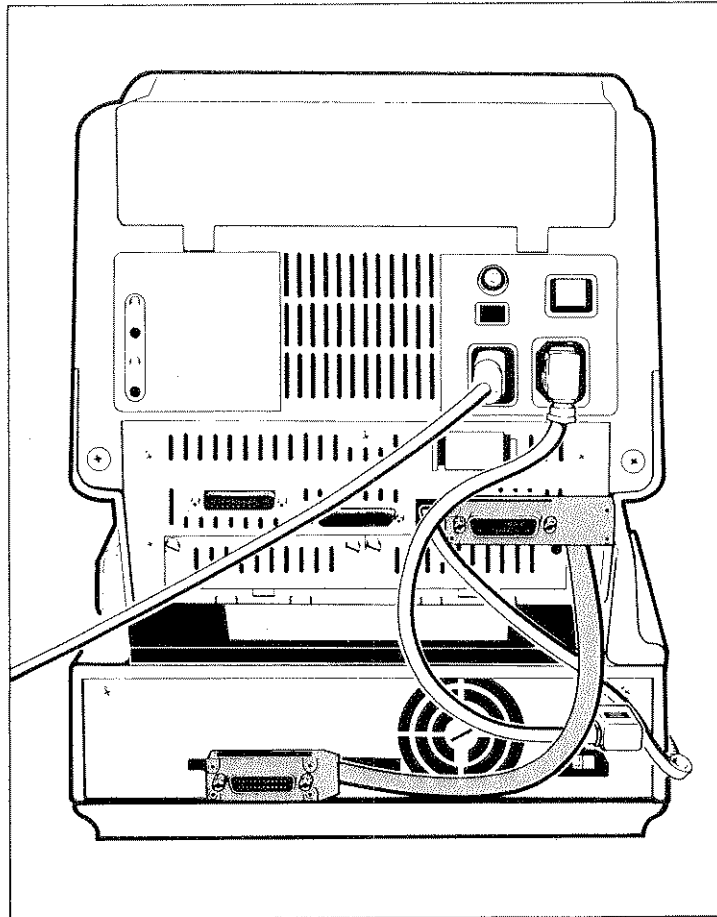

Figure 4 : Câble d'interface HP-IB entre l'ordinateur et l'unité de disques



## Positionnement des adresses

Votre numéro de téléphone est différent de celui de votre voisin. Grâce à ce numéro spécial, on peut entrer en communication avec vous et vous demander des renseignements. De même, chaque périphérique doit avoir un numéro d'appel unique pour que l'ordinateur puisse entrer en communication avec lui, fournir des informations ou lui en demander. Le terme "adresse" désigne ce numéro spécial.

Adresse	Position des quatre petits sélecteurs			
	Gauche	Milieu Gauche	Milieu Droit	Droite
0	Baissé	Baissé	Baissé	Baissé
1	Baissé	Baissé	Baissé	Levé
2	Baissé	Baissé	Levé	Baissé
3	Baissé	Baissé	Levé	Levé
4	Baissé	Levé	Baissé	Baissé
5	Baissé	Levé	Baissé	Levé
6	Baissé	Levé	Levé	Baissé
7	Baissé	Levé	Levé	Levé

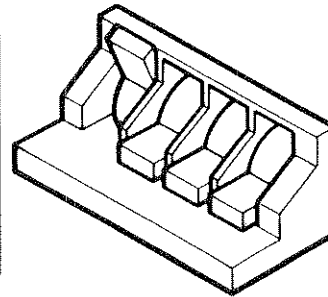

Figure 5 : Positionnement des Adresses

- Chaque périphérique doit porter une adresse unique
- Hewlett-Packard met votre unité à disques de l'adresse 0, tel qu'illustré dans la figure 5.
- Si vous disposez seulement d'une unité de disques, d'une table traçante, et d'une imprimante reliées à votre ordinateur, vous n'avez pas besoin de changer l'adresse définie en usine. Si vous devez changer l'adresse:
  - Mettez l'unité de disques hors tension
  - Mettez les quatre petits sélecteurs d'adresse sur l'une des adresses présentées dans la figure 5.

## Connexion du câbles d'alimentation

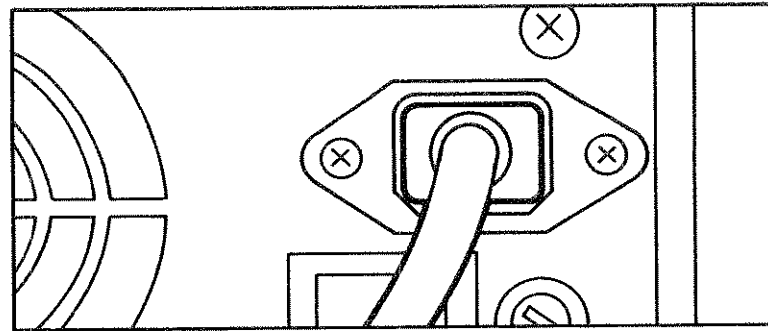
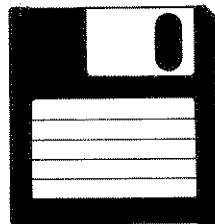

Figure 6 : Connexion du câble d'alimentation

- Mettez votre unité de disques hors tension
- Connectez le câble d'alimentation à la prise marquée "AC line" à l'arrière de l'appareil.
- Enfoncez le connecteur du câble d'alimentation dans la prise murale.

## Manipulation des disques souples



**PENSEZ** à pousser le volet protecteur avant de ranger le disque.

**POURQUOI?** pour le protéger des poussières, rayures et empreintes.



**PENSEZ** à utiliser le disque dans un environnement propre.

**POURQUOI?** pour minimiser le risque des poussières et particules qui vont rayer la surface du disque.

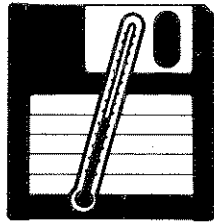

PENSEZ à ranger les disques  
verticalement dans un  
lieu sec et tempéré.

POURQUOI? Pour prévenir les  
dégats provoqués par  
la chaleur et  
l'humidité.



PENSEZ à éviter les champs  
magnétiques des  
moteurs d'appareils.

POURQUOI? pour protéger les  
données contre  
l'effacement.

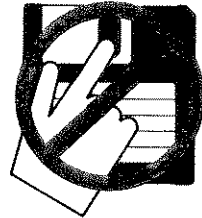

EVITEZ de toucher la surface  
du disque.

POURQUOI? pour que les corps  
étrangers ne le rayent  
pas et soient la cause  
d'usure prématurée.



EVITEZ de nettoyer le disque  
POURQUOI? parce que l'enveloppe  
en plastique comporte  
un système de  
nettoyage de la  
surface. Toute autre  
méthode peut  
endommager le disque.

## Disques simple face et double faces

Le HP 9122 enregistre sur les deux faces du disque. Pour une utilisation, nous recommandons les disques gris double face de Hewlett-Packard pour le HP 9122.

Le HP 9121 n'enregistre que sur une face. C'est pourquoi nous recommandons pour cet appareil les disques bleus simple-face Hewlett-Packard.

Le tableau I fournit les détails relatifs aux disques simple face et double face. Les termes utilisés correspondent aux définitions suivantes:

- "Format simple face" signifie que les données sont enregistrées sur une seule face.
- "Format double face" signifie que les données sont enregistrées sur les deux faces.
- "Echange de données seulement" signifie que le disque devrait n'être utilisé que pour copier les données et les programmes; il ne devrait pas servir de façon quotidienne.
- "OK" signifie que le disque peut servir quotidiennement.
- "NON" signifie que le disque ne peut pas servir quotidiennement.

	Avec un HP 9121	Avec un HP 9122 <sup>1</sup>
Simple face	OK	Echange de données seulement
Double face en format simple face	OK	OK
Double face en format double face	NON	OK
Logiciel HP Simple face ou double face <sup>2</sup>	OK	OK

<sup>1</sup> Seuls des disques avec volet de protection automatique peuvent être utilisés dans le HP 9122.

<sup>2</sup> Logiciel fourni par Hewlett-Packard et conçu spécialement pour le système ordinateur/disque qui l'utilisera.

Tableau I : Recommandations d'utilisation pour disques simple face et double face.

## Languelette de protection en écriture

- La languelette protège le disque contre l'effacement des données par un nouvel enregistrement.
- Protégez en écriture des disques qui contiennent des programmes et des données de valeur.
- Regardez la figure 6 si vous souhaitez protéger en écriture un disque double face, et la figure 7 si vous desirez protéger en écriture un disque simple face.

Si vous désirez protéger en écriture un disque double face pour le HP 9122:

- Enfoncez la pointe d'un stylo dans le petit trou qui se trouve au-dessus de la languelette de protection rouge.
- Abaissez la languelette jusqu'à ce qu'elle se mette en place.
- Lorsque vous ne voulez plus protéger le disque, remontez la languelette rouge.

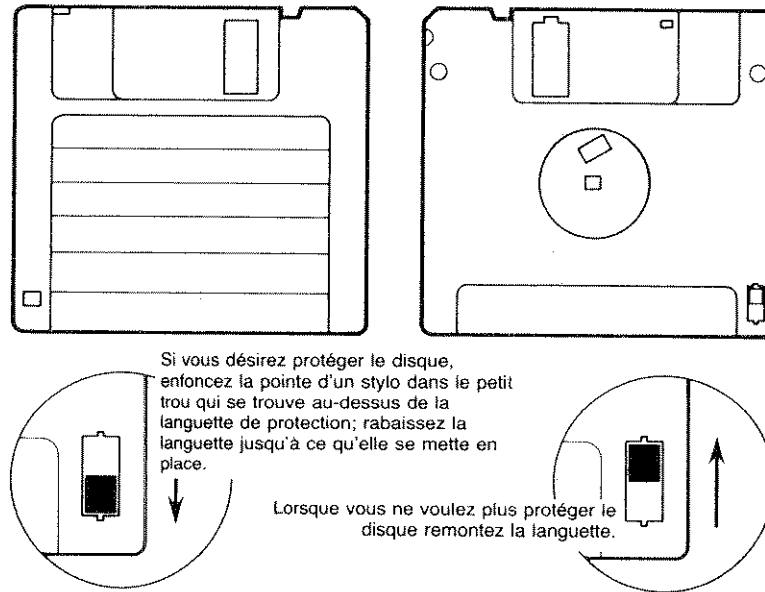

Figure 6 : Protection en écriture pour le HP 9122

Si vous désirez protéger en écriture un disque simple face pour le HP 9121:

- Utilisez un tourne-vis ou la pointe d'un stylo pour soulever délicatement la languette et la dégager.
- Renversez la languette de côté et poussez-la près de l'encoche.
- Enfoncez-la jusqu'à ce qu'elle se mette en place.
- Si vous ne voulez plus protéger le disque en écriture, remontez la languette.

Si votre disque ne contient pas de languette de protection, cela signifie que le disque est protégé. Si pourtant vous souhaitez enregistrer sur ce disque, il vous suffit de mettre un morceau d'adhésif sur la fente de façon à annuler la protection.

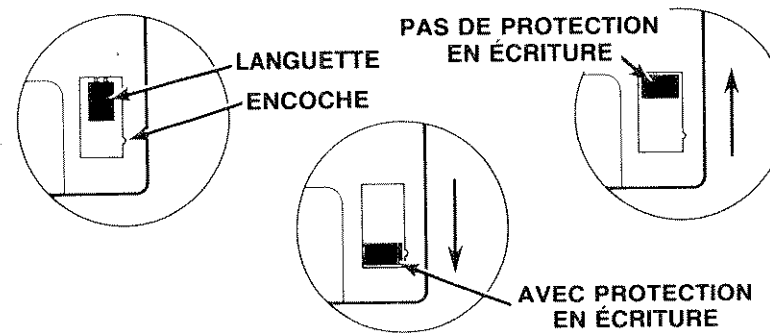

Figure 7 : Protection en écriture pour le HP 9121

## Surveillance des supports magnétiques

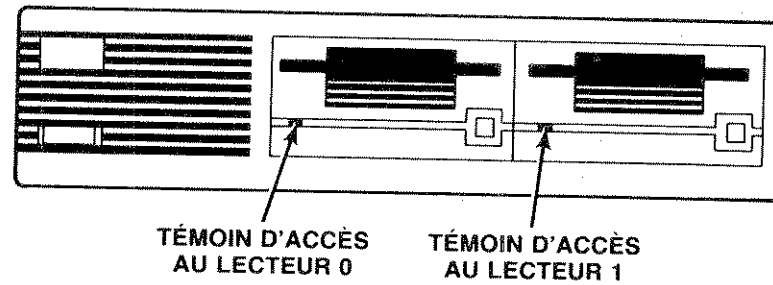

Figure 8 : Emplacement du témoin d'accès au disque à l'avant de l'appareil.

- Grâce à un dispositif spécial, le Moniteur de supports magnétiques, votre appareil surveille l'utilisation d'un disque dans le temps.
- Quand l'utilisation en arrive au point de risquer la perte de données due à l'usure, le témoin d'accès clignote et on entend un tic-tac quand l'ordinateur *n'utilise pas* le disque.
- Dès que possible, copiez le disque que vous utilisez sur un disque neuf. Jetez le disque endommagé.

## Utilisation de l'unité de disques

- Vous voilà prêt à utiliser votre unité de disques.
- Pour tous renseignements relatifs à l'activité entre l'unité à disques et l'ordinateur, consultez le chapitre concernant la configuration dans le manuel d'utilisation de votre ordinateur.
- Pour tous renseignements relatifs au formatage des disques et à l'élaboration de copies de secours, consultez le chapitre concernant l'unité de disques et le stockage de masse du manuel d'utilisation de l'ordinateur.
- On peut aussi trouver les renseignements sur la configuration, le formatage et la copie dans le chapitre 3 de la deuxième partie de ce manuel.

---

# Parte 1

---

---

## GUIDA PER L'INSTALLAZIONE

---

### Scopo di questo manuale

Questo manuale è costituito da due parti: una guida all'installazione ed una sezione di consultazione. La Parte I è la guida all'installazione. Seguendo le illustrazioni e il testo nella Parte I potrete connettere la vostra unità disco al computer e imparare ad usare i dischi flessibili. Questa guida per l'installazione è presentata in cinque lingue.

La seconda parte del manuale è una sezione di consultazione. Questa sezione spiega il contenuto della guida per l'installazione e vi dà anche informazioni su cosa fare se c'è qualche cosa che non va. Questo materiale è presentato in inglese.

Le pagine di questo manuale sono perforate tra la copertina e la perforazione a tre fori. Potete quindi facilmente togliere ed eliminare le parti del manuale di cui non avete bisogno. Se lo desiderate, potete anche estrarre le parti del manuale che volete conservare ed inserirle in un raccoglitore a tre fori, come ad esempio il vostro raccoglitore del manuale del computer.

Potete facilmente estrarre le pagine perforate piegando prima lungo la perforazione. Cominciate dal margine superiore o da quello inferiore e staccate la pagina con un leggero e continuo strappo.



# Date uno sguardo alla vostra unità disco



Figura 1: Pannelli frontale e posteriore degli HP 9121/9122

- Notate le parti della vostra unità disco illustrate nella figura 1.
- In particolare, localizzate l'interruttore di alimentazione, il fusibile, il commutatore di tensione, il commutatore di indirizzo, la connessione HP-IB ed il connettore della linea AC.

# Guardate le attrezzature che vi sono fornite

Le seguenti attrezzature sono fornite con ogni unità disco 9121/9122:

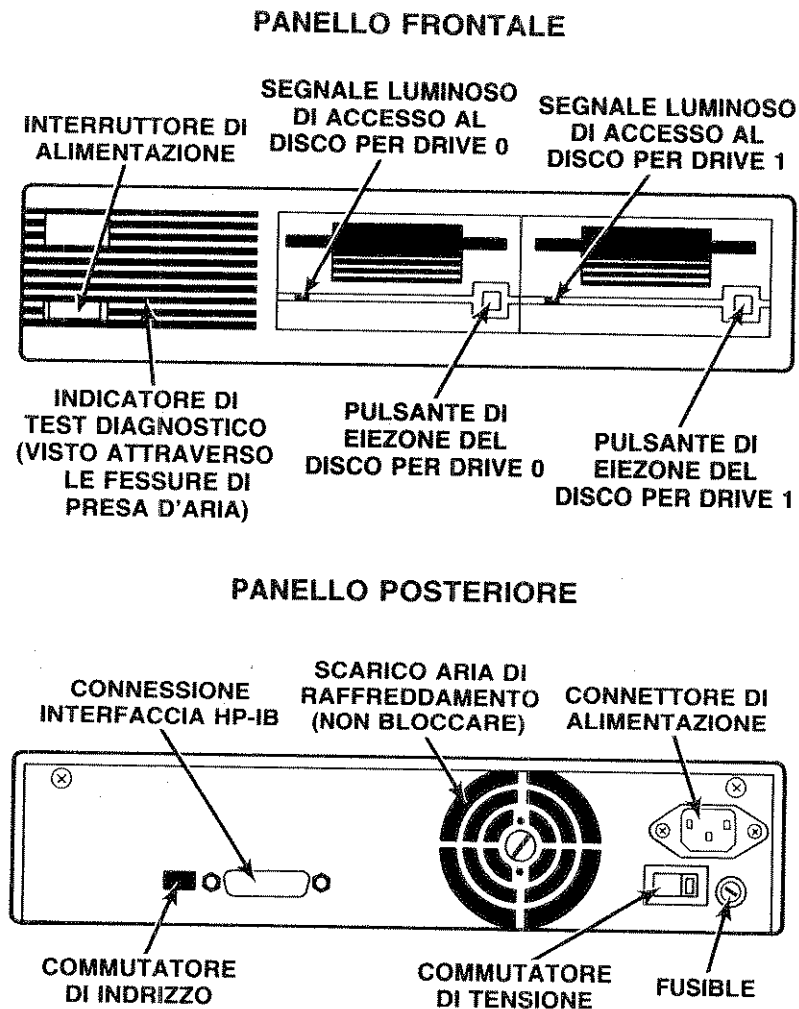
- Cavo di alimentazione
- Manuale d'uso

## Installazione

### Posizionamento della tensione



Figura 2: Posizioni del commutatore di tensione

---

#### ATTENZIONE

Disinserite sempre l'unità disco prima di cambiare tensione per evitare di danneggiare l'unità.

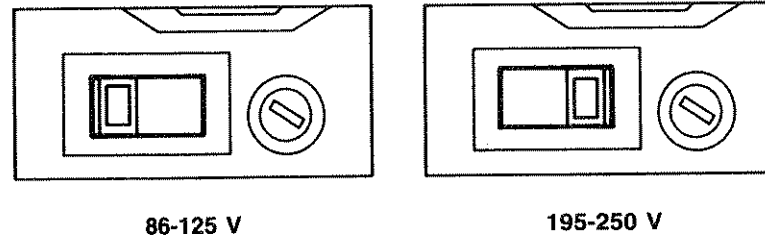
---

- Localizzate il commutatore di tensione rosso sul pannello posteriore della vostra unità disco.
- Accertatevi che il commutatore di tensione sia nella posizione corretta per la tensione locale.
- Se necessario, usate un cacciavite per spostare il commutatore di tensione da un lato all'altro fino a quando non è nella posizione corretta.

## Sostituzione del fusibile

### ATTENZIONE

A CAUSA DELLA POSSIBILITÀ DI PERICOLO DI SCOSSA ELETTRICA, DISINNESTATE SEMPRE IL CAVO DI ALIMENTAZIONE SE DOVETE SOSTITUIRE UN FUSIBILE. Inserite il fusibile nel porta-fusibili e poi nell'unità.

Posizionamento della tensione	Gamma della tensione	Fusibile richiesto
115V	86-125 VAC	1.0 Amp 250 VAC
230V	195-250 VAC	0.5 Amp 250 VAC

Figura 3: Fusibili

- Il fusibile nella vostra unità disco dovrebbe corrispondere al posizionamento della tensione.
- Assicuratevi di avere il fusibile corretto per la tensione nella vostra area.

### Connessione del cavo HP-IB

- Spegnete l'unità disco.
- Innestate un capo del cavo HP-IB nel connettore HP-IB dell'unità disco.
- Innestate l'altro capo del cavo HP-IB nel connettore HP-IB del computer.
- La figura 4 illustra l'aspetto del cavo HP-IB con un computer HP150. Se avete un altro tipo di computer la connessione HP-IB sul vostro computer può essere in una posizione diversa.



Figura 4: Cavo HP-IB che connette il computer e l'unità disco.

## Posizionamento dell'indirizzo

Avete un numero di telefono diverso da quello del vostro vicino. Il vostro numero di telefono permette agli altri di chiamarvi quando hanno un messaggio per voi o quando hanno bisogno di informazioni. Allo stesso modo, ogni dispositivo periferico su un bus deve avere un numero di telefono particolare, in modo che il computer possa "chiamare" l'unità periferica per ricevere o dare informazioni. Sul bus, questo numero particolare è chiamato un indirizzo.

Indirizzo	Posizione di 4 piccoli commutatori			
	Sinistra	Centro Sinistra	Centro Destra	Destra
0	Basso	Basso	Basso	Basso
1	Basso	Basso	Basso	Alto
2	Basso	Basso	Alto	Basso
3	Basso	Basso	Alto	Alto
4	Basso	Alto	Basso	Basso
5	Basso	Alto	Basso	Alto
6	Basso	Alto	Alto	Basso
7	Basso	Alto	Alto	Alto

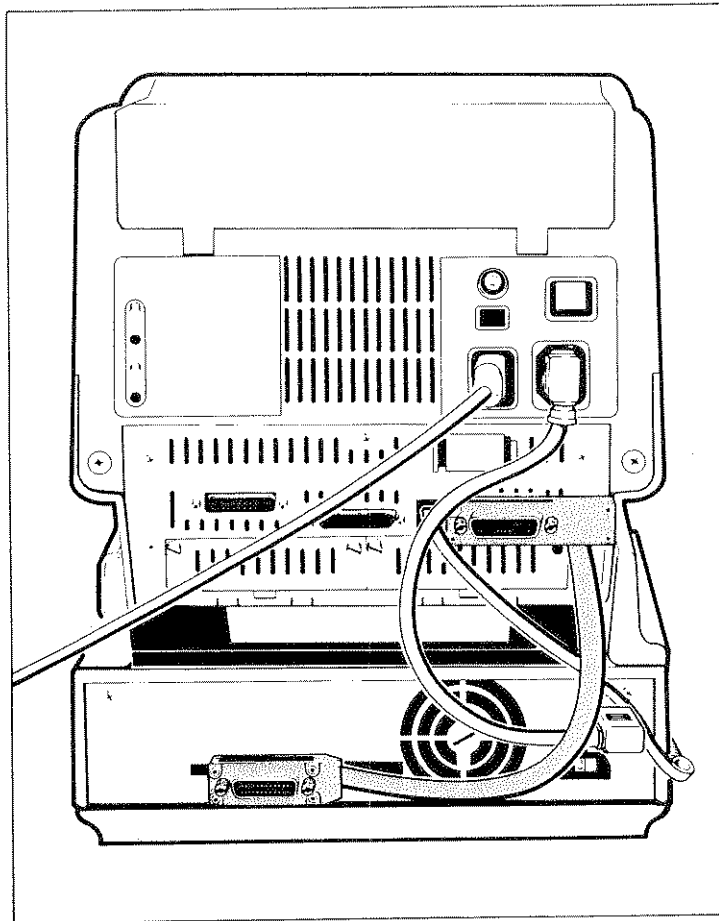

Figura 5: Posizionamento del commutatore di indirizzo

- Ogni dispositivo periferico deve avere un indirizzo particolare
- La Hewlett-Packard posiziona l'indirizzo della vostra unità disco a 0 (illustrato nella figura 5).
- Se avete soltanto un'unità disco, un plotter ed una stampante connessi al vostro computer non dovrete aver bisogno di cambiare indirizzo.
- Se dovete cambiare indirizzo:
  - Disinserite l'unità disco
  - Posizionate i quattro piccoli commutatori di indirizzo su uno degli indirizzi illustrati nella figura 5.

## Connessione del cavo di alimentazione

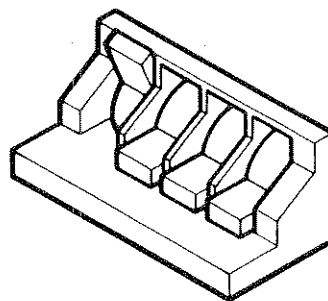

Figura 6: Connessione del cavo di alimentazione

- Spegnete l'unità disco.
- Collegate il cavo di alimentazione al connettore contrassegnato "AC line" sul pannello posteriore.
- Innestate il cavo di alimentazione nella presa murale.

## Maneggio del disco flessibile

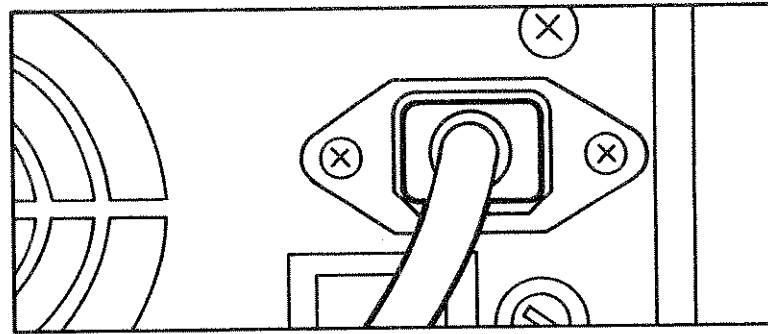
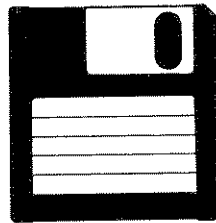

FATELO

Assicuratevi che l'otturatore sia chiuso quando il disco non è in uso.

PERCHÉ?

Ciò protegge il disco da polvere, impronte digitali e scalfitture.



FATELO

Usate il disco in un ambiente pulito.

PERCHÉ?

Per minimizzare il rischio che polvere o particelle di sporcizia scalfiscano il disco.

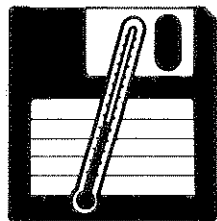

FATELO

Conservate i dischi in posizione verticale, in luogo fresco e secco.

PERCHÉ?

Per prevenire danni dovuti a umidità e calore.



FATELO

Evitate campi magnetici, come le apparecchiature con motori.

PERCHÉ?

Per evitare la cancellatura magnetica dei dati sui vostri dischi.

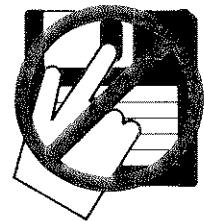

NON FATELO Non toccate la superficie del disco.

PERCHÉ?

La contaminazione da particelle può scalfire il disco o causarne l'usura prima del normale.



NON FATELO Non cercate di pulire il disco.

PERCHÉ?

La custodia di plastica contiene un meccanismo per pulire la superficie del disco. Altri metodi di pulizia possono danneggiare il disco.

## Dischi a faccia singola e dischi a doppia faccia

L'HP 9122 registra dati su ambedue le facce di un disco. Per l'uso giornaliero, raccomandiamo i dischi Hewlett-Packard grigi a doppia faccia con un HP 9122.

L'HP 9121 registra dati solo su una faccia del disco. Per uso giornaliero, raccomandiamo i dischi Hewlett-Packard blu a faccia singola con un'HP 9121.

	Se avete un'unità HP 9121	Se avete un'unità HP 9122 <sup>1</sup>
Disco HP a faccia singola	OK	Solo scambio di dati
Disco HP a doppia faccia in formato a faccia singola	OK	OK
Disco HP a doppia faccia in formato a doppia faccia	NO	OK
Software HP – a faccia singola o a faccia doppia <sup>2</sup>	OK	OK

<sup>1</sup> Solo dischi con otturatore automatico possono essere usati nell'HP 9122.

<sup>2</sup> Il software fornito dalla Hewlett-Packard è stato concepito specificamente per il sistema computer/disco su cui il software verrà usato.

**Tavola I: Uso raccomandato dei dischi a faccia singola in paragone ai dischi a faccia doppia.**

La tavola I descrive dettagliatamente questo uso raccomandato di dischi a faccia singola o doppia. Le parole usate nella tavola sono definite come segue:

- "Formato a faccia singola" significa che i dati sono registrati solo su una faccia del vostro disco.
- "Formato a doppia faccia" significa che i dati sono registrati su ambedue le facce del vostro disco.



- "Solo scambio di dati" significa che il disco dovrebbe essere usato solo per copiare dati e programmi e non dovrebbe essere usato su base giornaliera.
- "OK" significa che il disco può essere usato su base giornaliera.
- "NO" significa che il disco non può essere usato.

## Protezione contro la sovrascrittura

- La protezione contro la sovrascrittura assicura che l'unità disco non possa scrivere sopra alle informazioni sul disco o cancellarle.
- Proteggete contro la sovrascrittura dischi che contengono programmi e dati di valore.
- Seguite la figura 6 se volete proteggere contro la sovrascrittura un disco a doppia faccia e la figura 7 se volete proteggere contro la sovrascrittura un disco a faccia singola.



Figura 6: Linguetta di protezione contro la sovrascrittura nell'HP 9122

Se volete proteggere contro la sovrascrittura un disco a due facce per l'HP 9122:

- Inserite la punta di una penna nel forellino sopra alla linguetta di protezione contro la sovrascrittura.
- Spostate la linguetta verso il basso fino a quando non si blocca al suo posto.
- Se non volete più proteggere il disco contro la sovrascrittura, spostate la linguetta verso l'alto.

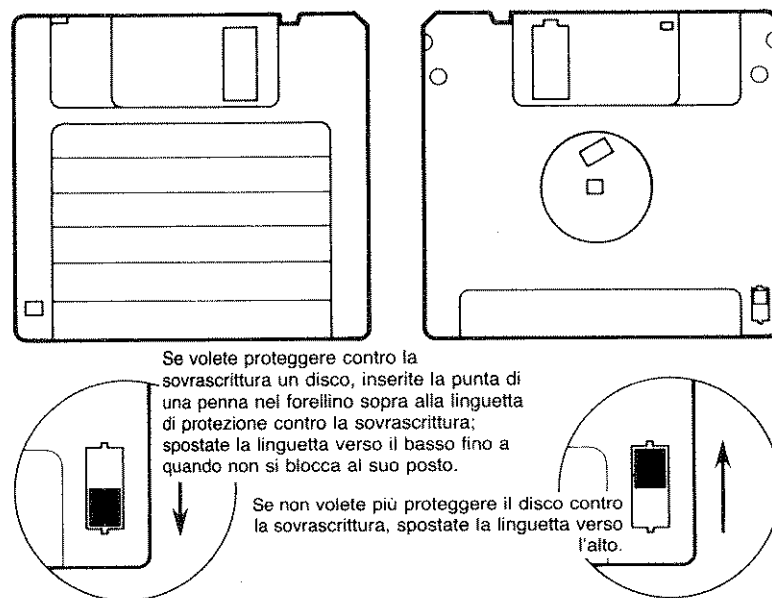

Figura 7: Linguetta di protezione contro la sovrascrittura nell'HP 9121

Se volete proteggere un disco a faccia singola contro la sovrascrittura per l'HP 9121:

- Usate un cacciavite o la punta di una penna per sollevare leggermente e staccare la linguetta
- Girate le linguetta di fianco e posizionalatela accanto alla scanalatura
- Premete fino a quando la linguetta non entra al suo posto.
- Se non volete più proteggere il disco contro la sovrascrittura, spostate la linguetta verso l'alto, via dalla scanalatura.

Se avete un disco in cui manca la linguetta di protezione contro la sovrascrittura, il disco è protetto contro la sovrascrittura. Se volete escludere la protezione contro la sovrascrittura, potete mettere del nastro adesivo sulla finestrella della linguetta per poter scrivere dati sul disco.

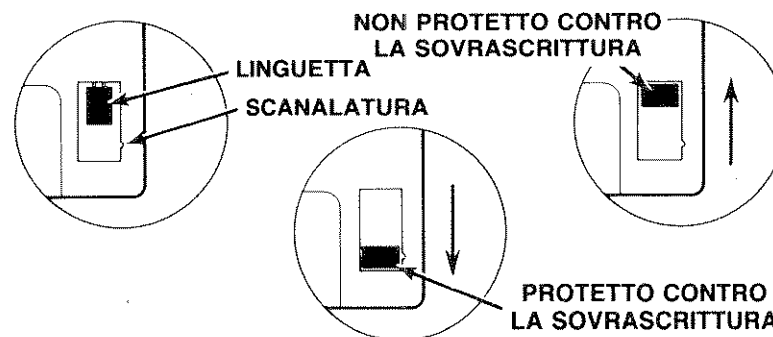
## Controllo del disco



Figura 8: Posizione del segnale luminoso di accesso al disco sul pannello frontale della vostra unità disco

- Attraverso un dispositivo chiamato Media Monitor la vostra unità disco controlla l'uso cumulativo di un disco.
- Quando l'uso si avvicina ad un livello che comporta un qualsiasi rischio di perdita di dati a causa della normale usura del disco, il segnale di accesso del disco lampeggia e si sente un ticchettio quando il computer NON sta usando il disco.
- Appena potete, copiate il disco che state usando e cominciate ad usare la copia. Eliminate il disco originale.

## Uso dell'unità disco

- Ora siete pronti ad usare la vostra unità disco.
- Per informazioni sul come configurare la vostra unità disco con il vostro computer fate riferimento alla sezione sulla configurazione nel manuale d'uso del computer.
- Per informazioni sulla formattazione dei dischi e sulla copiatura dei dischi, fate riferimento alla sezione sull'unità disco o sulla memoria di massa nel manuale d'uso del computer.
- Informazioni sulla configurazione, formattazione, e copiatura sono incluse anche nella Parte II, Capitolo III di questo manuale.

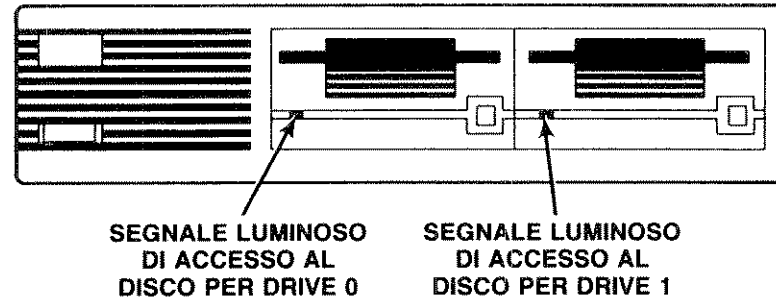
---

## Part II

---

---

## REFERENCE SECTION

---

### What is an HP 9121/9122 Disc Drive?

A disc drive is a device that allows a computer to read data that is stored on a disc or write data to a disc. A disc is similar to a phonograph record that stores programs and data instead of music. A disc may be flexible or hard. Data may be stored on only one side of the disc (single-sided) or on both sides of the disc (double-sided).

The HP 9121/9122 family of disc drives uses 3 1/2-inch flexible discs. The HP 9121 uses single-sided flexible discs, while the HP 9122 uses double-sided flexible discs. This manual describes both the HP 9121 and HP 9122 disc drives since these disc drives are similar in appearance and use.

Figure 1-1 describes the storage capacities for the HP 9121/9122 family of disc drives.

Disc Drive	Number of Drives	Type of Discs Used	Maximum Kbytes of Storage	Approximate Number of Typewritten Pages of Storage*
9122D	2	Double-sided	1,420	354
9122S	1	Double-sided	710	177
9121D	2	Single-sided	540	135
9121S	1	Single-sided	270	68

\* Based on 80 characters per line of type and 50 lines of type per page.

### Storage Capacities

Now that you know a little bit about this manual and your disc drive, let's set up your disc drive.



---

# Chapter 1

---

---

## GETTING SET UP

---

*The installation instructions in this part of the manual are in greater detail than in Part I of this manual.*

### Step 1: Unpacking and Checking the Equipment Supplied

Remove your disc drive from the shipping carton. Your disc drive was carefully inspected before shipment. However, please check the unit for any physical damage that may have occurred during shipment. If you find any damage, immediately notify your dealer or the nearest Hewlett-Packard sales office. Also, file a claim with the carrier.

---

#### CAUTION

The disc drive is a precision instrument. Mechanical shock which occurs as a result of the disc drive being dropped may misalign the read/write heads and/or other internal parts. Damage may occur whether the disc drive is operating or not.

---

If you plan to move the disc drive to another site in the future, save the shipping carton. When the time for the move arrives, make sure that you remove all discs from the disc drive. Seal the disc drive in a plastic bag and repack it in the shipping carton.

Your disc drive comes with a power cord and an operator's manual. Please verify that you have received this equipment. If you are missing either of these items, please contact your dealer or the nearest HP sales office.

One 3 1/2-inch flexible disc per drive is included with your operator's manual. A package of ten flexible discs may be ordered. If you have an HP 9122, you need gray double-sided discs; order part number 92192A. Specify part number 92191A for blue single-sided discs for the HP 9121.

## Step 2: A Look at Your Disc Drive

Before you set up your disc drive, look at the parts of the disc drive illustrated in Figure 2-1. On the front panel of your disc drive, locate the power switch, the disc eject button for each drive unit, and the disc access light for each drive unit. Your disc drive is turned on when the power switch button is in. The disc drive is off when the button is out.

The disc access light is illuminated whenever your computer is storing data on the disc or retrieving data from the disc. The disc access light is also lit up momentarily when the disc drive is first turned on and when a new disc is inserted.

---

### CAUTION

The disc access light on the front of each drive indicates usage of that drive. Do not depress the disc eject button when the disc access light is on. Also, do not turn off the disc drive when the disc access light is on.

---

Please note the cooling air exhaust on the rear panel. When positioning your disc drive, ensure that this exhaust is not blocked.

---

### CAUTION

Keep the front and back of the disc drive free from obstructions in order to avoid restricting the air flow. Failure to do so could cause the unit to overheat and result in damage to the unit.

---

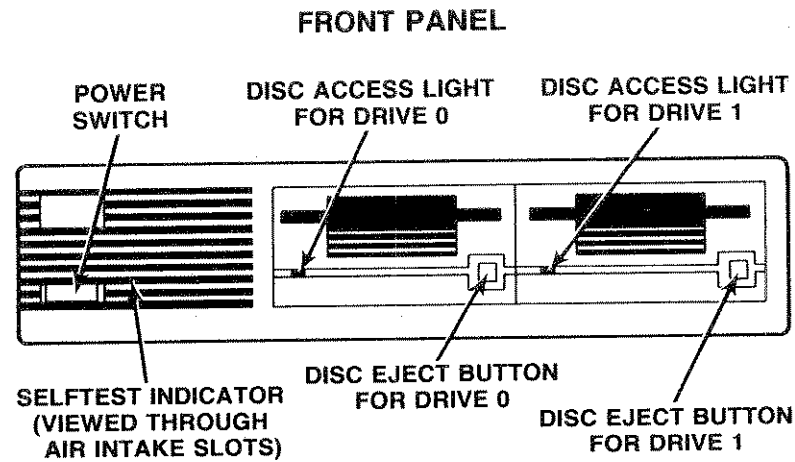

Figure 2-1: Front and Rear Panels of the HP 9121/9122

## Step 3: Setting Up and Connecting Your Disc Drive to Your System

### Before You Start

The only tool you need to set up your disc drive is a small blade screwdriver. If a screwdriver is not available, a nail file, pocket knife, coin, or similar tool may be substituted.



The five steps involved in setting up a disc drive include:

- 1) setting the voltage,
- 2) installing the fuse,
- 3) connecting the HP-IB cable,
- 4) setting the address, and
- 5) connecting the power cord.

During the manufacturing process, Hewlett-Packard completes steps 1, 2, and 4. Therefore, at this time, you may not need to install the fuse or reset the voltage and address switches on your disc drive. You do need to connect the HP-IB cable and power cord.

### First, Set the Voltage Switch

---

#### WARNING

Always turn off the disc drive before changing the voltage setting in order to avoid damage to the disc drive.

---

Place your disc drive on a flat surface with the rear panel facing you. Be sure the disc drive is turned off. Check the voltage switch (see Figure 1-2). This switch was set for the voltage in your area prior to shipment, either 115 VAC (United States) or 230 VAC (Europe). Verify that the switch is set correctly for your local power. If necessary, you can change the setting by using a screwdriver to push the voltage switch sideways until the switch displays the proper setting.

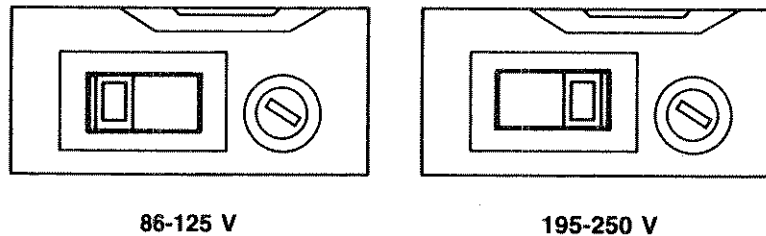

Figure 1-2: Voltage Switch

## Second, Changing the Fuse

### WARNING

TO AVOID POTENTIAL SHOCK HAZARD, ALWAYS UNPLUG THE POWER CORD BEFORE CHANGING FUSES. To install the fuse, first place the fuse into the fuse-holder and then into the unit.

The fuse in your disc drive corresponds to the voltage setting. If your voltage is 115 VAC, a 1.0 Amp fuse is required. If your voltage is 230 VAC, a 0.5 Amp fuse is necessary.

If you need to change the fuse, first unplug the unit. Then use a screwdriver to turn the fuse-holder in a counter-clockwise direction while pushing gently (see Figure 1-3). Once the fuse-holder is loosened, pull it out with your fingers. Remove the old fuse. Put the new fuse into the fuse-holder and then insert the fuse-holder into the unit. Do not hold the metal portion of the fuse while inserting the fuse into the unit, because if the unit is plugged in a potential shock hazard exists.

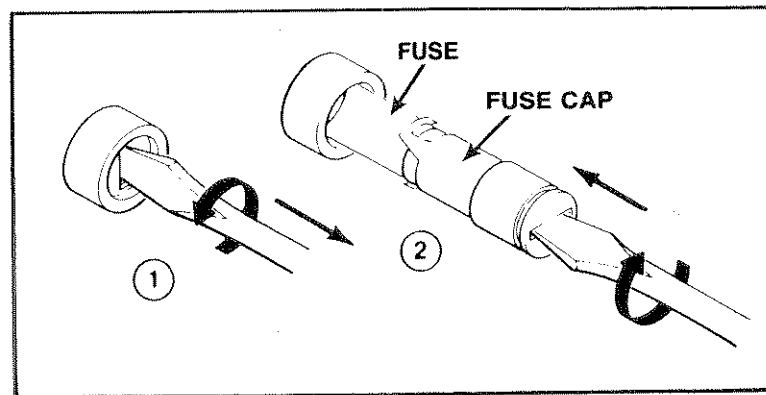

Figure 1-3: Fuse holder

### Third, Connect the HP-IB Cable

The disc drive is connected to the computer using the Hewlett-Packard Interface Bus (HP-IB), illustrated in Figure 1-4. A bus is a bundle of wires over which computer devices can communicate. The bus is similar to a telephone line shared by several telephones. The computer, disc drives, plotters, and printers are the "telephones" hooked to this telephone line. (Just as telephones must have a unique phone number, each one of these devices must have a unique number. On the bus, these unique numbers are called addresses. You will learn how to assign a unique address to your disc drive in the section called, "Select the Address.")

Length	Accessory Number
1 meter	10833A
2 meters	10833B
4 meters	10833C
0.5 meters	10833D

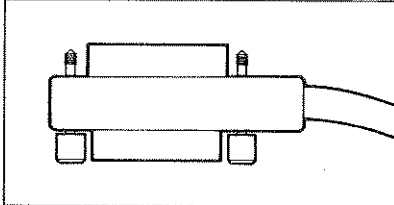
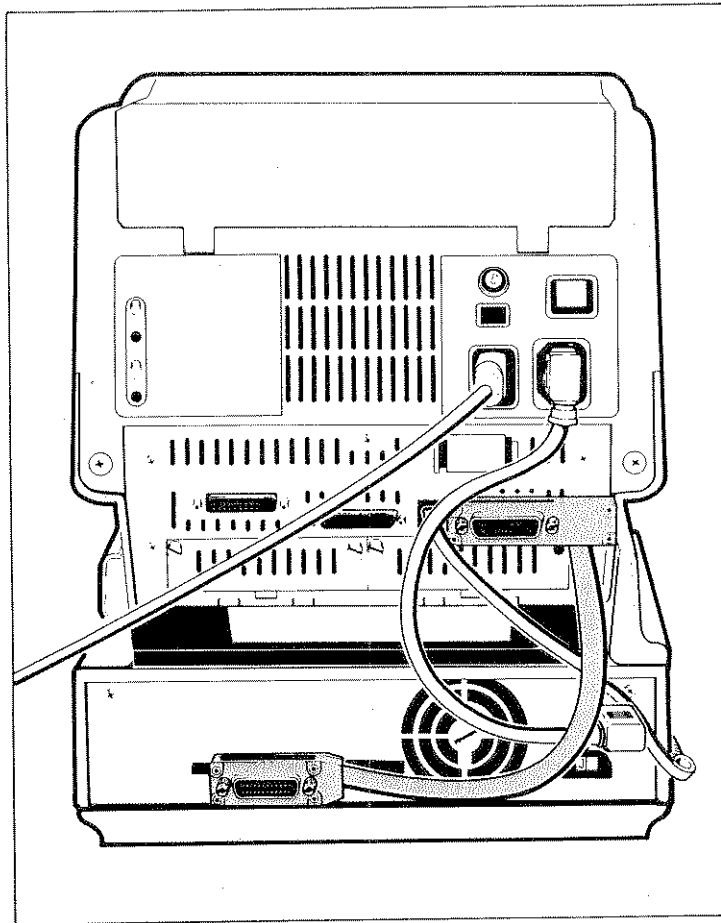

Figure 1-4: HP-IB Cable

The HP-IB cables from Hewlett-Packard (listed in Figure 1-4) are completely shielded to eliminate Radio Frequency Interference (RFI). The use of unshielded cables will cause increased RFI in the area of use.

Use the following steps to connect your disc drive to your computer using the HP-IB cable.

1. Make sure that the power switch on your computer and on your disc drive are turned off.
2. Plug one end of the HP-IB cable into the HP-IB socket on the rear panel of your disc drive (See Figure 1-5). The socket is shaped so that the HP-IB cable can only be plugged in one way. Once the HP-IB is connected, secure the connection by turning the thumbscrews on the HP-IB connector in a clockwise direction.
3. Plug the other end of the HP-IB cable into the HP-IB socket on your computer, and secure using the thumbscrews (see Figure 1-5).



Note: This figure illustrates the connection on an HP Touchscreen computer. If you have a different computer the connection may appear slightly different.

Figure 1-5: HP-IB Connection

If you examine the HP-IB cable you have just hooked up, you will note that the side of the HP-IB cable facing you looks very similar to the HP-IB socket on the back of your disc drive. This means that you can now plug another HP-IB cable into the back of the cable you have just hooked up. This stacking of HP-IB cables is called piggybacking. Piggybacking allows you to hook up more than one peripheral to your computer. The most important point to remember when piggybacking is to stack no more than four HP-IB cables on one piece of equipment. Placing too much weight on any HP-IB socket may damage the socket. See Appendix I for additional information on HP-IB interface restrictions.

#### Fourth, Select the Address

You have a telephone number that is different from your neighbor's telephone number. Your telephone number allows others to call you when they have a message for you or when they need information from you. Similarly, each peripheral device on a bus needs a unique number so that the computer can "call" the peripheral to get or give information. On the bus, this unique number is called an address.

Hewlett-Packard sets your disc drive address at 0. You probably do not need to change this address if you have only one peripheral of each type (e.g. one disc drive, one printer, and one plotter) connected to your computer. The reason is that HP usually sets the disc drive address at 0, the printer address at 1, and the plotter address at 5. Therefore, when you have only one peripheral of each type, these peripherals probably have unique addresses.

Check the peripherals that you are connecting to your computer. The address switches can be set to any one of eight addresses, ranging from 0 through 7. Figure 1-6 illustrates these eight addresses.

Address	Position of 4 small switches			
	Left	Middle Left	Middle Right	Right
0	Up	Down	Down	Down
1	Up	Down	Down	Up
2	UP	Down	UP	Down
3	Up	Down	Up	Up
4	Up	UP	Down	Down
5	Up	Up	Down	Up
6	Up	Up	Up	Down
7	Up	Up	Up	Up

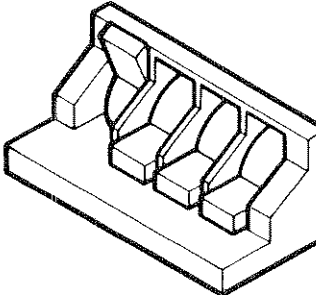

Figure 1-6: Address Switch Settings

If you need to change the address on your disc drive, use the following steps to set the address:

1. Make sure your disc drive power switch is "OFF".
2. Look at the address switch on your disc drive. The switch is actually four small switches.

3. Compare the four switches to Figure 1-6. In the figure, the switches are described as being "up" or "down". Think of the switches in comparison to your light switches at home. You can flip your light switch up or down. When the switch is at the top, it is "up". When the switch is at the bottom, it is "down".
4. As an example, look at the address "0" in Figure 1-6. When the address is set at "0", the first, second and third switch from the right are all down. The switch farthest to the left is up. For all addresses, this left switch should be up for normal operation.
5. Using Figure 1-6, set your disc drive address to a unique address.

While your unit may contain two separate drives, it is one device. Therefore, only one address is required. However, when reading data from or writing data to the disc drive, you must specify not only the address, but also the unit number of the drive you are using. On your unit, the left drive is labelled "0" for unit 0 or drive 0. The right drive is labelled "1". See the configuration section of your computer operator's manual or Chapter 3 of this manual for more information on this subject.

### **Fifth, Connect the Power Cord**

A power cord was packaged with your equipment. Make sure that your disc drive and computer are turned off. Connect the power cord to the socket labelled "AC Line" on the right rear panel (see Figure 1-7). Plug the power cord into the wall socket. Contact your dealer or the nearest HP sales office if you do not have the correct power cord.

---

#### **WARNING**

If it is necessary to replace the power cord, the replacement cord must be identical to the original cord. Otherwise a shock hazard might exist. If you need to replace a power cord, contact your dealer or the nearest HP sales office for the appropriate HP part number.

---

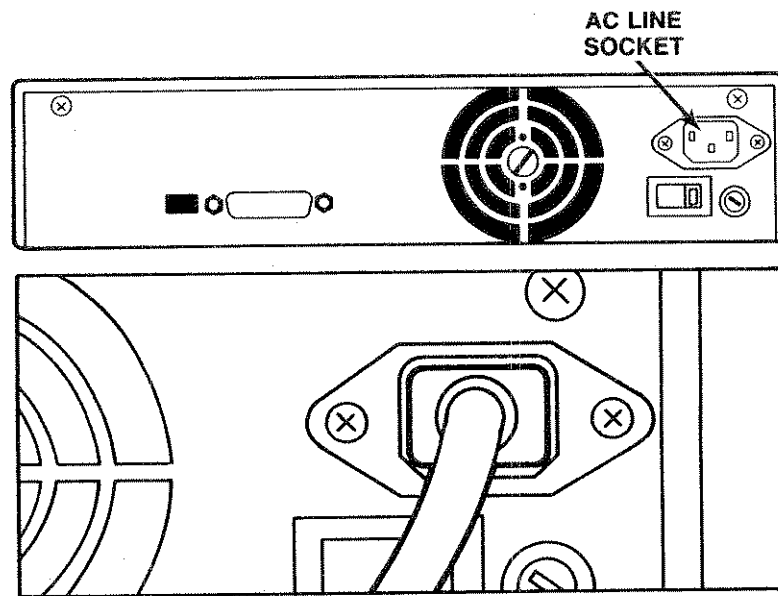

Figure 1-7: Power Cord Connection

## Step 4: Try It!

### Power-On Selftest

If you have performed all of the above procedures, you are ready to turn on your disc drive. Locate the power button on the front panel. When the button is in, the disc drive is on. When the button is out, the disc drive is off.

A power-on selftest is performed automatically when you turn on your disc drive. Figure 1-8 illustrates the location of the selftest light. This light may be viewed through the air intake slots on the front panel of your disc drive. However, this light is visible only when it is lit. When you know where to locate the selftest light, turn on your disc drive. Watch the selftest light.

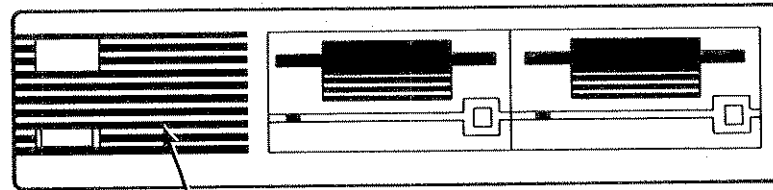

**SELFTEST INDICATOR  
(VIEWED THROUGH  
AIR INTAKE SLOTS)**

**Figure 1-8: Selftest Light Location**

**If you have an HP 9122**, the selftest light should be illuminated less than 1 minute and then go out. When the light goes out, the disc drive has passed the selftest. If the selftest indicator light continues to burn after 1 minute, turn off the disc drive. Then turn on the disc drive and repeat the observation of the selftest light. If after several retries of this selftest, the indicator light continues to be lit, contact your dealer or the nearest HP sales office.

**If you have an HP 9121**, the selftest light flashes five times to indicate that the disc drive has passed the selftest. If the light does not flash, turn off the disc drive. Make sure you are looking behind the air intake slots for the indicator light, and then turn on the disc drive again. If no flashing occurs after trying this test several times, contact your dealer or the nearest HP sales office.



---

## Chapter 2

---

---

### USING YOUR FLEXIBLE DISC

---

#### What is a Flexible Disc?

A flexible disc is similar to a phonograph record that stores programs and data instead of music. The computer can record data and programs on the disc and can later recall the programs and data from the disc.

The flexible disc is made from a flexible mylar sheet coated with a thin layer of magnetic oxide. This mylar sheet is enclosed in a protective plastic jacket designed to keep the recording surface clean. The plastic jacket also helps keep the disc flat when the disc is rotating in your drive.

## A Look at the Flexible Disc

Figure 2-1 illustrates the parts of the flexible disc. As you read the following description, please note the described features on your disc.

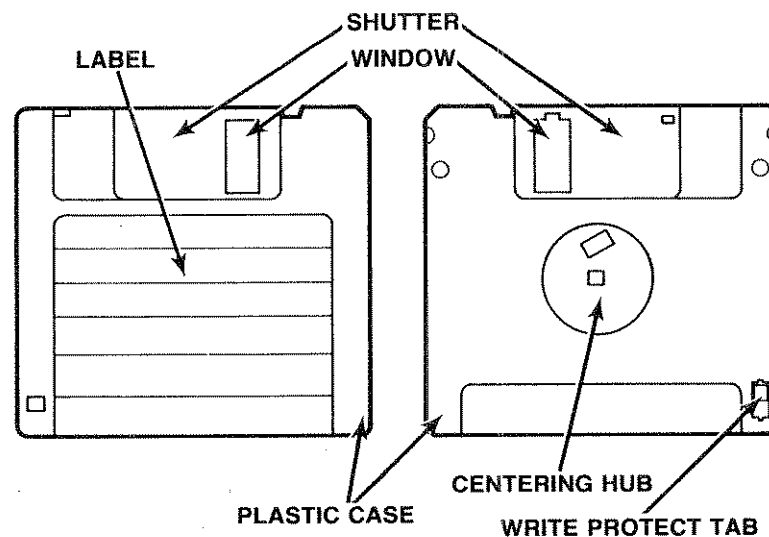

Figure 2-1: Parts of the Flexible Disc

### Window and Auto Shutter

The disc drive reads data from the disc and writes data on the disc in the space under the window. The window is covered by a metal shutter. The shutter helps protect the disc surface from particles and accidental fingerprints.

The flexible disc is equipped with an auto shutter. This means that when the disc is placed in the drive, the shutter is automatically opened to expose the disc surface. You do not need to manually open the shutter before inserting the disc in the drive.

If you have an **HP 9122**, the auto shutter on your double-sided discs can be held open for visual inspection of the disc surface. When you let go of the shutter, it will automatically snap shut.

If you have an **HP 9121**, the auto shutter on your single-sided discs may be opened and closed manually. Open the auto shutter by sliding the shutter to the left until it locks in place. Close the auto shutter by pinching the upper left corner of the disc.

---

**NOTE**

Original 3 1/2-inch flexible discs did not have the auto shutter feature. If you have a flexible disc that is not labelled "auto shutter" on the shutter, you must manually slide back the shutter before inserting the disc into the drive. After removing the flexible disc from the drive, you must manually close the shutter in order to protect the disc. You can only use discs with auto-shutters in the HP 9122.

---

### **Centering Hub**

On the back of the plastic jacket is a round metal center, called the centering hub. The centering hub ensures rapid and accurate positioning when the disc is inserted in the drive.

## **Single-Sided Versus Double-Sided Discs**

Please refer to Part I, the Installation Guide, for information on single-sided versus double-sided discs.

## **Loading the Flexible Disc**

To insert and remove flexible discs, perform these steps.

1. Turn on the disc drive. Do not insert a disc before you have turned on the disc drive.
2. Hold the disc with the label on the top and the shutter pointing at the slot in the disc drive. Slide the disc into the drive until you feel the disc drop into the slot. Do not force the disc. See figure 2-2 for proper loading of the disc.

If you have a disc that is **NOT** auto shutter, you must manually open the shutter before inserting the disc into the drive or the disc will not drop down into the drive.

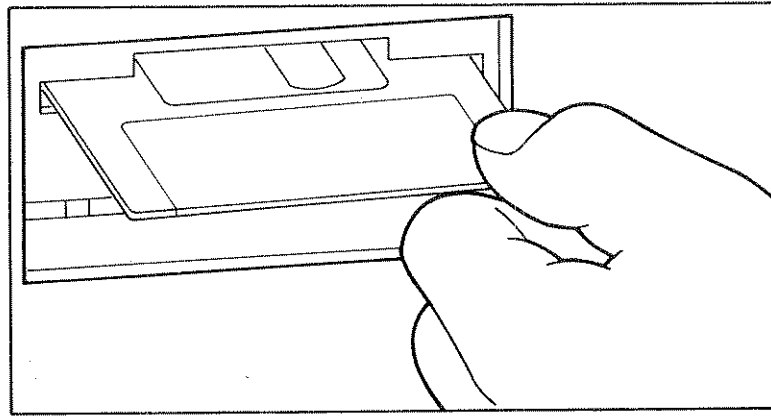

Figure 2-2: Proper Loading of the Flexible Disc

3. Remove the disc by pressing the disc eject button. Pull the disc straight out.  
If you have a disc that is NOT auto shutter, you must manually close the shutter immediately after removing the disc from the drive.
4. Turn off the disc drive only after you have removed the disc.

## Labeling the Flexible Disc

When you order boxes of flexible discs, you receive a packet of labels with the discs. Note that the labels come in a variety of colors. Position the label on the disc so that the colored portion of the label is folded over the lower edge of the disc (see Figure 2-3).

You can establish a color-coded system for cataloging your discs. For example, discs containing memos may be labeled in red while discs containing personnel files can have blue labels. Store your discs upright in a container so that the colored edge of the labels are visible. You may use the colors to select the category of discs you desire, and then read the labels to select the specific disc needed.

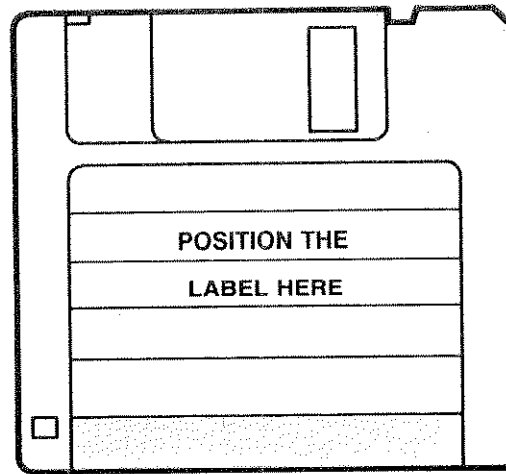

Figure 2-3: Usual Positioning of the Label on the Disc

## What is the Life Expectancy of a Flexible Disc

The read/write head of the disc drive touches the disc. As a result, the flexible disc media does wear out. The Media Monitor indication helps assure reliable operation.

### Media Monitor

Through a feature called Media Monitor, your disc drive automatically monitors the cumulative use of each individual disc. When the usage of a disc is approaching a level at which there is any risk of loss of data through normal disc wear, the disc access light on the front panel blinks (see Figure 2-4), and a clicking sound is heard when the the computer is NOT using the disc. Once this point has been reached in the life span of a disc, the disc drive accepts commands from the computer and performs the commands. However, after a command has been performed, the disc drive immediately resumes the warning indication.

When the Media Monitor warning occurs, immediately copy your disc. If you continue to use this disc, the disc drive eventually automatically write protects the disc. After that time, you will only be able to read data from the disc or copy the disc.

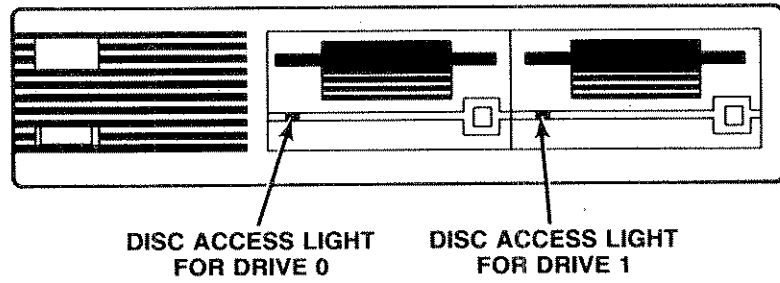

The disc access light will blink and a clicking sound is heard when the Media Monitor has determined that the disc should be replaced.

Figure 2-4: Location of Media Monitor Lights

## Warranty

The complete warranty statement for the U.S. and Canada is included inside the front cover of this manual. If you have questions concerning the warranty, please contact your dealer or the nearest HP sales office. In countries other than the U.S. and Canada, contact your dealer or the nearest HP sales office for the warranty statement.

## Maintenance

Your disc drive does not require regular maintenance. However, the performance and life of the disc drive and the flexible discs depend on how carefully they are handled. Be sure to follow the disc care and handling guidelines presented in Part I and the environmental restrictions presented in the Specifications Table in Appendix I.

If you have an HP 9121, a part of the disc drive known as a load pad will wear out and must be replaced. (The HP 9122 does not have load pads.) The replacement of the load pad is a complicated process and should only be attempted by a trained service person.

The life expectancy of the load pad depends on the use of the drive. A normally used drive (disc access light lit less than 20 minutes per day) requires load pad replacement approximately every 5 years. A heavily used drive (disc access light lit more than 2 hours per day) requires load pad replacement every 1 to 2 years.

## What If Something Goes Wrong?

1. *What if the disc access light begins blinking and the disc drive makes a clicking noise?*

The blinking of the disc access light and the clicking noise are a feature of your disc drive, called the Media Monitor. This warning indicates that the disc currently in use in the blinking and clicking drive should be replaced. Immediately copy the worn disc and discard it. For further information about the Media Monitor, please see the "Media Monitor" section of Chapter 2.

2. *What if my disc drive does not pass the selftest?*

If your disc drive does not pass the selftest, take the following actions:

- A) Turn off your disc drive. Then turn the disc drive back on and repeat the selftest.
- B) If the disc drive still fails the selftest, repeat the selftest 2 to 3 more times.
- C) If your disc drive still fails the selftest, contact your dealer or the nearest HP sales office.

3. *When I try to initialize my disc, I get an error stating that the disc is write protected. What should I do?*

First, check to make sure that you are not using a disc that you have write protected or that has been automatically write protected by the Media Monitor.

When a disc is inserted to be initialized, the disc drive performs a motor speed check. If the motor speed is out of specification a Write Protect Error is generated and the disc is not initialized. This indicates a defective disc. Discard the disc.

Please note that if you receive a Write Protect Error on several discs in a row, your disc drive may not be operating properly. Contact your dealer or the nearest HP sales office.

4. *When I try to store information on a disc, I get an error stating that the disc is write protected. What should I do?*

You are trying to store information on a disc that you have write protected. If you wish to write information on this disc, reverse the write protect tab on the disc (see Part 1). If you wish to keep this disc write protected, insert another disc.

Also, the disc may have been automatically write protected by the Media Monitor. If the Media Monitor warning is on, the disc should be discarded.

5. *What should I do if I get a message that says, "Disc Not Present" or "No Discs Were Found"?*

- A) Be sure the disc drive is turned on.
- B) Check your cables to make sure they are secure.
- C) Be sure that you have a disc in the correct disc drive.
- D) Be sure that the disc has been initialized.
- E) Check your disc drive to make sure it is addressed correctly.
- F) If all this fails, you may have a bad disc. Try another disc.



6. *What if I get an error message saying, "Disc Error Reading Drive — \_\_\_\_\_?"*

Your disc is probably worn or damaged. Try using other discs to see if you get the same message. If you receive the message on only one disc, copy the disc immediately and discard it. (Please note that if the disc is worn or damaged, the copy may not work.) If you receive the same message on several discs, contact your dealer or HP sales office.

7. *What should I do if I get a message that says, "Disc drive is empty, off, or undefined"?*

- A) Be sure the disc drive is turned on.
- B) Be sure that you have a disc in your disc drive.
- C) Check your disc drive to make sure it is addressed correctly.
- D) If all this fails, you may have a bad disc. Try another disc.

Your disc drive can be repaired only by a trained service person. If you suspect that your disc drive is malfunctioning, contact your dealer or the nearest HP Sales Office.

## How to Order Supplies

DESCRIPTION	HP PART NUMBER
Blue Single-Sided Micro Flexible Discs (10 discs/box)	92191A for 9121
Gray Double-Sided Micro Flexible Discs (10 discs/box)	92192A for 9122
Fuse, 1.0 amp for voltage range of 86-125VAC	2110-0001
Fuse, 0.5 amp for voltage range of 195-250VAC	2110-0012
Power Cord <sup>1</sup>	See footnote
HP-IB Cable, 1 meter length	10833A
HP-IB Cable, 2 meter length	10833B
HP-IB Cable, 4 meter length	10833C
HP-IB Cable, 0.5 meter length	10833D
HP 9121/9122 Operator's Manual	09122-90000

<sup>1</sup> Power cords are dependent on delivered location. Please consult your dealer or nearest HP sales office if you need to order a power cord.

Order supplies for your disc drive by contacting your dealer or the nearest HP sales office. You may also contact the Hewlett-Packard Computer Supplies Operation at the following address:

Computer Supplies Operation  
1320 Kifer Road  
Sunnyvale, California 94086

Telephone: (800) 538-8787 toll free in the United States  
(408) 738-4133 in California

---

# Appendix I

---

---

## TECHNICAL REFERENCE

---

### HP-IB Interface Restrictions

The total length of cable permitted in one bus system must be less than or equal to two meters times the number of devices connected together (your computer counts as one device). However, the total length of cable must not exceed 20 meters.

For example, a system containing six devices can be connected together with cables that have a total length less than or equal to 12 meters (six devices  $\times$  2m/device = 12 meters). The individual lengths of cable may be distributed in any manner desired as long as the total length does not exceed the allowed maximum. If more than ten devices are to be connected together, cables shorter than two meters must be used between some of the devices to keep the total cable length less than 20 meters.

The maximum number of devices that may be connected together in one bus system is 15. Up to eight of these devices may be disc drives. There are no restrictions to the way cables may be connected together. However, it is recommended that no more than four piggyback connectors be stacked together on one device. The resulting structure could exert enough force on the connector mounting to damage it.

# For HP-IB Programmers Only

The HP 9121/9122 disc drives do not support the following HP-IB commands:

Serial Poll  
Parallel Poll Configure  
Parallel Poll Unconfigure

---

## NOTE

Parallel Poll Response occurs at the HP-IB address to which the rear panel switches have been set.

---

## Technical Specifications

Listed next are the electrical and physical specifications for the HP 9121/9122 disc drives.

	HP 9121S HP 9122S	HP 9121D HP 9122D
Number of drives	1	2
Net Weight	3.6 kg (8.5 lbs)	4.5 kg (10 lbs)
Height	76 mm (2.99 in.)	76 mm (2.99 in.)
Depth	285 mm (11.2 in.)	285 mm (11.2 in.)
Width	325 mm (12.8 in.)	325 mm (12.8 in.)
	HP 9121D/S	HP 9122D/S
Interface	HP-IB	HP-IB
HP Double Density Format		
Encoding:	MFM	MFM
Rotational Speed:	600 RPM	600 RPM
Bit Density @ 600 RPM:	Track 69 (Inside track) 7610 BPI	Track 69 8717 BPI
Track Density:	135 tracks per inch	135 tracks per inch
Tracks per Surface:	70	80
Surfaces used per disc:	1	2
Capacity		
Bytes/Sector:	256	512
Tracks:	70	80
Bytes/Drive (Formatted):	270 Kbytes	710 Kbytes
See note below.		

---

**NOTE**

All of HP's computers spare tracks for data reliability. These tracks are not used for data storage. As a result, the usable space on the HP 9121 is 270 Kbytes/drive. The usable space on the HP 9122 is 710 Kbytes/drive maximum.

---

	HP 9121D/S	HP 9122D/S
<b>Access Time</b>		
Track-to-Track Seek:	15 ms/track plus 20 ms settling	15 ms/track plus 42 ms settling
Maximum Track-to-Track Seek:	1070 ms (70 tracks)	1242 ms (80 tracks)
Average Track-to-Track:	370 ms	447 ms
Maximum Rotational Latency:	100 ms	100 ms
Average Rotational Latency:	50 ms	50 ms
Spindle Motor on time:	1 s	400 ms
Maximum Data Access Time (Seek plus Latency plus Motor on time):	2.170 s	1.742 s
Average Data Access Time:	420 ms	497 ms
 <b>Data Transfer Rates:</b>		
	Maximum Sustained Transfer Rate (256 bytes/sector)	Maximum Sustained Transfer Rate (512 bytes/sector)
Interleave	HP 9121/9122	HP 9122
2	16.0K	17.6K

---

**NOTE**

The above transfer rates are possible on a Series 200 computer. Transfer rates may vary depending on the system and software programs used. Performance on systems other than Series 200 may be lower.

---

**Power Requirements**

86-125 volts or 195-250 volts @ 67 watts RMS (94 voltamps)  
50-60 Hertz  
Fuse 1A, 250 for 115V setting

Environmental Specs

Operating Limits

Temperature:

10°C to 40°C  
(50°F to 104°F)

Humidity:

20 to 80% with maximum wet bulb  
temperature (non-condensing) not  
to exceed 29°C (85°F).

Altitude:

0 to 4572 m (0 to 15,000 ft)

Non-operating Limits  
(Storage and Transit)

Temperature:

- 40°C to 60°C  
(- 40°F to 140°F)

Altitude:

- 304 to 15240 m (- 1000 to 50,000 ft)

---

NOTE

Your disc drive is designed for operation in a typical office environment. Use of the equipment in an environment containing dirt, dust, or corrosive substances will drastically reduce the life of the disc drive and of the flexible discs.

---

---

## Appendix II

---

---

## GLOSSARY

---

ADDRESS

A number that identifies the exact location to which your computer can send data or from which your computer receives data. Just as you have a unique home address, your computer, disc drive, plotter and printer must each have a unique address.

BACKUP

A backup is a duplicate copy of a disc made in case the original disc is lost or damaged.

BOOTING

Booting up your computer puts it in a ready-to-run condition. The computer literally "pulls itself up by it's bootstraps" and gets ready to go. (Booting loads the operating system and utilities.)

BYTE

A byte is used to represent one character, such as a single letter, number, or other symbol.

CABLE

Cables provide the connection between computers and peripherals (printers, plotters, and disc drives). The cable used in this manual is the HP-IB (Hewlett-Packard Interface Bus).

CONFIGURATION

Configuration is the way you let your computer know which disc drive it is talking to, where the disc drive is on the bus, and which drive you want the computer to access.

CRT

Acronym for cathode ray tube. The CRT is the video screen of the computer.

DIRECTORY	The table of contents for the files stored on a disc.
DISC	A circular plate of magnetically coated material used to store computer information. The disc is similar to a phonograph record that stores programs and data instead of music. HP's 3 1/2-inch flexible disc is enclosed in a plastic jacket.  A disc may be flexible or hard. The flexible disc may also be single-sided or double-sided.
DISC DRIVE	A device that allows a computer to read data that is stored on a disc or write data on a disc.
FORMATTING	The process by which a disc is prepared to receive and store data. Also known as "initializing."  If you think of your disc as being like a filing cabinet, formatting is equivalent to getting an empty file cabinet and preparing the cabinet for use. First, you check the cabinet for any damage. Similarly, the disc drive checks the disc for any damaged areas in which data cannot be stored. Second, you place hanging folders and dividers in your file cabinet. Likewise, the disc drive sets up storage areas on the disc. Finally, you label your filing cabinet so that you know what is in each drawer. Similarly, the disc drive sets up a directory on your disc.
HARDWARE	The physical parts of the computer system; the computer and the peripheral devices.
HEAD	The part of the disc drive that reads data from your disc and writes data onto your disc.
HP-IB	Stands for Hewlett-Packard Interface Bus. The HP-IB is a bundle of wires that allows the computer and the peripherals to communicate.
INITIALIZING	The process by which a disc is prepared to receive and store data. Also known as "formatting."
INTERFACE	The interface makes communication possible between the computer and its peripherals.



INTERLEAVE

Interleaving a disc is a method of alternately numbering sectors on the disc to improve data acquisition efficiency. See the interleave section of your computer programming manual for additional information.

KBYTES

A unit of measurement for memory storage. One Kbyte is technically equal to 1,024 bytes. However, we use Kbyte to mean 1,000 bytes. Also called "K" or "kilobyte."

LOAD

To read programs into a computer.

MEMORY

The size of the computer's brain. Memory is the combination of hardware and/or discs on which data is stored.

MFM

Modified frequency modulation (MFM) is a method for storing data on discs.

PERIPHERALS

Devices that are external to and controlled by the computer. Peripherals are so called because they are not part of the computer (e.g. tape drives, disc drives, printers, and plotters).

PIGGYBACKING

Hooking one HP-IB cable into the back of another HP-IB cable. Piggybacking is one way to connect more peripheral devices to your computer system.

PROGRAM

A set of instructions or steps telling the computer how to handle a problem or task.

READ/WRITE  
HEAD

The part of the disc drive that reads data from your disc and writes data onto your disc.

SOFTWARE

A computer program or set of programs.

UTILITY

A utility is a program that performs a task required by most users. For example, most users need to make copies of discs. Therefore, the copy utility is a program that tells the computer how to copy discs.

WRITE PROTECT

A method of protecting disc information from being erased or overwritten.

---

# Index

---

---

---

---

## A

Access light	1, 12, 1-3, 2-5, 2-6, 4-2
AC line socket	2, 1-3
Address switch	2, 6, 1-3, 1-8
Air exhaust	2, 1-3
Auto shutter	2-2

## B

Backup	13
Button, disc eject	2, 1-3
Button, Power	2, 1-3

## C

Cable, HP-IB	2, 4, 1-6
Cable, how to order	4-4
Cable, power	3, 7
Capacity	II-1
Care of disc drive	4-1
Care of discs	7, 8
Centering Hub	2-2
Cleaning	4-1
Cooling air exhaust	2, 1-3
Cord, power	3, 7

## D

Device address	2, 6, 1-3, 1-8
Disc, double-sided	9

Disc eject button . . . . .	2, 1-3
Disc, flexible . . . . .	7, 8, 9, 10, 11, 12, 2-1
Disc handling . . . . .	7,8
Disc labeling . . . . .	2-4
Disc loading . . . . .	2-3
Disc, ordering . . . . .	4-4
Disc, single-sided . . . . .	9
Disc, storage . . . . .	8

### E

Eject button . . . . .	2, 1-3
Errors . . . . .	4-3

### F

Flexible disc . . . . .	see Disc
Formatting option . . . . .	see Supplement
Formatting Series 200 BASIC . . . . .	see Supplement
Formatting Series 200 Pascal . . . . .	see Supplement
Fuse . . . . .	2, 4, 1-3, 1-5
Fuses, how to order . . . . .	4-4

### H

Handling flexible discs . . . . .	7,8
HP-IB . . . . .	2,4, 1-3, 1-6
HP-IB Programming . . . . .	A-2
HP-IB Restrictions . . . . .	A-1
Hub, centering . . . . .	2-2

### I

Indicator light, selftest . . . . .	2, 1-3
-------------------------------------	--------

### L

Labeling discs . . . . .	2-4
Light, disc access . . . . .	1, 12, 1-3, 2-5, 2-6, 4-2
Light, selftest indicator . . . . .	2, 1-3
Loading flexible discs . . . . .	2-3

### M

Maintenance . . . . .	4-2
Media . . . . .	see Disc

Media monitor . . . . .	12, 2-5
Micro flexible disc . . . . .	see Disc

O

Ordering discs . . . . .	4-4
Ordering supplies . . . . .	4-4

P

Piggybacking . . . . .	1-7
Power cord . . . . .	2, 7, 1-9
Power on selftest . . . . .	1-10
Power switch . . . . .	2, 1-3
Problems . . . . .	4-2
Protect, write . . . . .	11, 12

S

Selftest . . . . .	1-10
Selftest, indicator light . . . . .	2, 1-3
Shutter . . . . .	2-2
Single-sided discs . . . . .	9
Storage capacity . . . . .	II-1
Supplies, ordering . . . . .	4-4
Switch, address . . . . .	2, 1-3, 1-8
Switch, power . . . . .	1, 1-3
Switch, voltage . . . . .	2, 3, 1-3, 1-4

T

Trouble-shooting . . . . .	4-2
----------------------------	-----

U

Unpacking . . . . .	1-1
---------------------	-----

V

Voltage switch . . . . .	2, 3, 1-3, 1-4
--------------------------	----------------

W

Warranty . . . . .	4-2
Window . . . . .	2-2
Write protect tab . . . . .	11, 12

## Worldwide Sales Offices

Hewlett-Packard products are sold and supported worldwide through Hewlett-Packard Sales and Service Offices and through dealers.

- *To contact Hewlett-Packard:* There are more than 240 Hewlett-Packard Sales and Service Offices worldwide. To locate the one nearest you, your telephone directory or contact one of the major Hewlett-Packard offices listed.
- *To contact a dealer:* Call 800/FOR-HPPC in the U.S. or call your local Hewlett-Packard Sales and Service Office. Ask for "Personal Computer Dealer Sales."

### Argentina

- \* Martinez  
Phone: 798-6086

### Australia

- \* North Ryde, N.S.W.  
Phone: 02/887-1611
- \* Blackburn, Victoria  
Phone: 03/890-6351

### Austria

- \* Vienna  
Phone: 222/3516210

### Belgium

- Supplies: 02/762-3200
- \* Brussels  
Phone: 02/762-3200

### Brazil

- \* Alphaville, Barueri  
Phone: 011/421-1311

### Canada

- Software Assistance:  
1-800/267-6115  
(in English and French)
- Supplies: 514/697-4232
- \* Edmonton, Alberta  
Phone: 403/452-3670
- \* Richmond, British Columbia  
Phone: 604/270-2277
- \* Mississauga, Ontario  
Phone: 416/678-9430

### Chile

- HP Distributor:  
Olympia (Chile)  
Santiago  
Phone: 2/25-5044

### Denmark

- \* Birkerød  
Phone: 2/81-66-40

### El Salvador

- HP Distributor  
IPESA  
San Salvador  
Phone: 503/26-6858

### Finland

- \* Espoo  
Phone: 90/455-0211
- \* Jyväskylä  
Phone: 41/216318
- \* Oulu  
Phone: 81/338785

### France

- Supplies: 6/928-32-64
- \* Les Ulis  
Phone: 1/9077825

### Guatemala

- HP Distributor:  
IPESA  
Guatemala City  
Phone: 2/31667

### Hong Kong

- \* Wanchai  
Phone: 5/832-3211

### Italy

- \* Cernusco Sul Naviglio  
Phone: 2/903691

### Japan

- Yokogawa-Hewlett-Packard
- \* Osaka  
Phone: 6/304-6021
- \* Sagami-hara  
Phone: 427/59-1311
- \* Tokyo  
Phone: 3/331-6111

### Malaysia

- \* Kuala Lumpur  
Phone: 03/943-022

### Mexico

- \* Xochimilco, Mexico City  
Phone: 905/676-8895

### The Netherlands

- Supplies: 020/47-06-39
- \* Amstelveen  
Phone: 020/472021

### New Zealand

- Pakuranga  
Phone: 9/68-7159

### Norway

- \* Oesteraas  
Phone: 2/17-11-80

### Puerto Rico

- Carolina  
Phone: 809/762-725

### Saudi Arabia

- \* HP Distributor:  
Modern Electronics  
Riyadh  
Phone: 01/4919715

### Singapore

- \* Singapore  
Phone: 631788

### South Africa

- Supplies: 802-5111  
53-7954  
28-4178
- \* Sandton, Transvaal  
Phone: 11/802-511

- \* Full Field Repair Center capabilities

### Spain

- \* Mirasierra, Madrid  
Phone: 91/734-1162

### Sweden

- \* Spanga  
Phone: 8/750-2000

### Switzerland

Supplies: 057/31-22-54  
or 31-22-59

- \* Widen  
Phone: 57/31-21-11

### Taiwan

- \* Taipei  
Phone: 2/712-0404

### United Kingdom

Supplies: 0734/79-2868  
or 0734/79-2959

- \* Altrincham  
Phone: 61/928-6422
- \* Widdersley, Wokingham  
Phone: 734/784-774

### United States

For assistance before your purchase, to locate an HP dealer, or to obtain your local Phone-In Software Assistance number: 800/FOR-HPPC

Hardware maintenance information or Dealer Repair Center locations: 800/835-HPHP

### Computer Supplies:

-All states except California, Alaska, and Hawaii:  
800/538-8787

-In California, Alaska, and Hawaii:  
408/738-4133 (collect)

- \* Santa Clara, California  
Phone: 408/988-7000
- \* Los Angeles, California  
Phone: 213/970-7500
- \* Englewood, Colorado  
Phone: 303/649-5000
- \* Atlanta, Georgia  
Phone: 404/955-1500
- \* Rolling Meadows, Illinois  
Phone: 312/255-9800

- \* Rockville, Maryland  
Phone: 301/948-6370

- \* Andover, Massachusetts  
Phone: 617/861-8960

- \* Novi, Michigan  
Phone: 313/349-9200

- \* Paramus, New Jersey  
Phone: 201/265-5000

- \* King of Prussia, Pennsylvania  
Phone: 215/265-7000

- \* Richardson, Texas  
Phone: 214/231-6101

### Venezuela

- \* Caracas  
Phone: 2/239-4133

### West Germany

Supplies: 07031/142829 or  
07031/223133

- \* Boeblingen  
Phone: 7031/667750

- 
- \* Full Field Repair Center capabilities.