

# **Service Guide**

## **Agilent Technologies**

### **PSG Family Signal Generators**

This guide applies to the signal generator models and associated serial number prefixes listed below. Depending on your firmware revision, front panel operation may vary from descriptions in this guide.

E8241A: US4124  
E8244A: US4124

E8251A: US4124  
E8254A: US4124



**Part Number: E8251-90030**

**Printed in USA**

**July 2001**

© Copyright 2001 Agilent Technologies.



**1. Troubleshooting**

Before Troubleshooting .....	1-2
ESD Information .....	1-2
Getting Started with Troubleshooting .....	1-3
To Run Self-Test .....	1-3
ILT-1 Power Supply Failure and Self-Test .....	1-4
ILT-2 Temperature Related Power Supply Failure .....	1-5
ILT-3 A18 CPU Turn-On Test .....	1-6
ILT4 Front Panel Display Troubleshooting .....	1-9
Symptom: Dark Display .....	1-9
Symptom: Bright Display Without Characters .....	1-10
Symptom: Hardkeys or Softkeys Not Functioning .....	1-12
Symptom: RPG Knob Not Functioning .....	1-14
Symptom: Screen Saver Not Functioning .....	1-14
Self-Test Failures and Related Troubleshooting .....	1-15
Troubleshooting Assembly Level Problems .....	1-17
Power Supplies .....	1-17
Self-Tests 2xx: A5 Sampler Self-Test Errors .....	1-24
Self-Tests 3xx: A7 Reference (Standard) Self-Test Errors .....	1-26
Self-Tests 4xx: A8 Output Self-Test Errors .....	1-27
Self-Tests 6xx: A9 YIG Driver Self-Test Errors .....	1-29
Self-Tests 7xx: A6 Frac-N Self-Test Errors .....	1-31
Self-Tests 9xx: A10 ALC Self-Test Errors .....	1-34
Self-Tests 10xx: A7 Reference (Option UNJ) Self-Test Errors .....	1-36
Self-Tests 11xx: A18 CPU Self-Test Errors .....	1-38
Self-Tests 12xx: A26 MID Self-Test Errors .....	1-40
Self-Tests 13xx: A11 Analog/Pulse Modulation Generator Self-Test Errors .....	1-43
Troubleshooting Unlocks .....	1-46
508 A6 Frac-N Loop Unlock .....	1-46
513 1 GHz Out of Lock .....	1-46
514 Reference Oven Cold .....	1-46
515 10 MHz Signal Bad .....	1-46
520 Sampler Unlocked .....	1-47
521 YO Loop Unlocked .....	1-47
625 Internal Pulse Generator Unlock .....	1-47
626 Internal Mod Source Unlock .....	1-48

---

# Contents

Troubleshooting Unlevels . . . . .	1-49
Troubleshoot and correct any unlock problems before troubleshooting unlevelled problems. . . . .	1-49
Troubleshooting Adjustment Problems . . . . .	1-53
Troubleshooting ADC Adjustment Failures. . . . .	1-55
Troubleshooting Performance Test Problems . . . . .	1-56
Troubleshooting the RF Path . . . . .	1-58
ALC and RF problems. . . . .	1-58
Troubleshooting Pulse Modulation . . . . .	1-59
Troubleshooting Problems <3.2 GHz. . . . .	1-59
Troubleshooting Problems >3.2 GHz. . . . .	1-60
Troubleshooting AT1 Attenuator . . . . .	1-61
Troubleshooting Harmonic Spurious . . . . .	1-62
20 GHz Models . . . . .	1-62
20 GHz Models . . . . .	1-63
40 GHz Models Only. . . . .	1-63
Troubleshooting Non-Harmonic Spurious . . . . .	1-65
Troubleshooting Option UNJ Phase Noise . . . . .	1-66
Overall Block Diagram . . . . .	1-67
Overall Block Description . . . . .	1-69
A19 Power Supply. . . . .	1-69
A18 CPU . . . . .	1-69
Input/Output Interface. . . . .	1-69
Frequency Generation . . . . .	1-70
Reference/Synthesis Loop Block Diagram . . . . .	1-73
Reference/Synthesis Loop Block Description. . . . .	1-75
A7 Reference . . . . .	1-75
A5 Sampler . . . . .	1-75
A6 Frac-N . . . . .	1-76
A9 YIG Driver . . . . .	1-76
A28 YIG Oscillator (YO). . . . .	1-76
A29 20 GHz Doubler. . . . .	1-76
RF Path Block Diagram . . . . .	1-77
RF Path Block Description (Frequency Generation, Level Control, and Modulation) . . . . .	1-79
Frequency Generation . . . . .	1-79

A29 20 GHz Doubler .....	1-79
A6 Frac-N .....	1-79
A8 Output .....	1-79
A30 Modulation Filter .....	1-80
A27 40 GHz Doubler .....	1-80
A23 Low Band Coupler/Detector, A24 High Band Coupler, and A25 High Band Detector .....	1-80
ALC Loop .....	1-80
A10 ALC .....	1-80
Modulation (AM, FM, PM, and Pulse) .....	1-81
Self-Test Overview .....	1-82
Contacting Agilent Technologies .....	1-84
Review the Warranty .....	1-84
Contacting Agilent Sales and Service Offices .....	1-85
Important Information Needed by an Agilent Service Representative .....	1-85
Returning Your Signal Generator for Service .....	1-86

## **2. Assembly Replacement**

Before You Replace an Assembly .....	2-2
After Replacing or Repairing an Assembly .....	2-2
Assemblies That You Can Replace .....	2-3
Outer Instrument Cover .....	2-4
Tools Required .....	2-4
Removal Procedure .....	2-4
Replacement Procedure .....	2-4
Inner Instrument Cover .....	2-6
Tools Required .....	2-6
Removal Procedure .....	2-6
Replacement Procedure .....	2-6
Front Panel .....	2-8
Tools Required .....	2-8
Removal Procedure .....	2-8
Replacement Procedure .....	2-9
A1 Keyboard .....	2-10
Tools Required .....	2-10
Removal Procedure .....	2-10
Replacement Procedure .....	2-10

---

# Contents

A2 Display	2-12
Tools Required	2-12
Removal Procedure	2-12
Replacement Procedure	2-12
A2DS1 Display Backlight	2-14
Tools Required	2-14
Removal Procedure	2-14
Replacement Procedure	2-14
A3 Power Switch	2-16
Tools Required	2-16
Removal Procedure	2-16
Replacement Procedure	2-16
A4 Inverter	2-18
Tools Required	2-18
Removal Procedure	2-18
Replacement Procedure	2-18
A5 Sampler	2-20
Tools Required	2-20
Removal Procedure	2-20
Replacement Procedure	2-20
A6 Frac-N	2-22
Tools Required	2-22
Removal Procedure	2-22
Replacement Procedure	2-22
A7 Reference (Standard and Option UNJ)	2-24
Tools Required	2-24
Removal Procedure	2-24
Replacement Procedure	2-24
A8 Output	2-26
Tools Required	2-26
Removal Procedure	2-26
Replacement Procedure	2-26
A9 YIG Driver	2-28
Tools Required	2-28
Removal Procedure	2-28
Replacement Procedure	2-28
A10 ALC	2-30

Tools Required .....	2-30
Removal Procedure .....	2-30
Replacement Procedure .....	2-30
A11 Pulse/Analog Modulation Generator .....	2-32
Tools Required .....	2-32
Removal Procedure .....	2-32
Replacement Procedure .....	2-32
A18 CPU .....	2-34
Tools Required .....	2-34
Removal Procedure .....	2-34
Replacement Procedure .....	2-34
A18BT1 .....	2-36
Tools Required .....	2-36
Removal Procedure .....	2-36
Replacement Procedure .....	2-36
A19 Power Supply .....	2-38
Tools Required .....	2-38
Removal Procedure .....	2-38
Replacement Procedure .....	2-38
Rear Panel .....	2-40
Tools Required .....	2-40
Removal Procedure .....	2-40
Replacement Procedure .....	2-40
A20 SMI (Source Module Interface) .....	2-42
Tools Required .....	2-42
Removal Procedure .....	2-42
Replacement Procedure .....	2-42
A21 Rear-Panel Interface .....	2-44
Tools Required .....	2-44
Removal Procedure .....	2-44
Replacement Procedure .....	2-44
A22 Line Module .....	2-46
Tools Required .....	2-46
Removal Procedure .....	2-46
Replacement Procedure .....	2-46
AT1 115 dB Attenuator (Option 1E1) .....	2-48
Tools Required .....	2-48

---

# Contents

Removal Procedure . . . . .	2-48
Replacement Procedure . . . . .	2-48
A23 Low Band Coupler/Detector . . . . .	2-50
Tools Required . . . . .	2-50
Removal Procedure . . . . .	2-50
Replacement Procedure . . . . .	2-50
A24 20 GHz High Band Coupler (E8241A and E8251A Models Only) . . . . .	2-52
Tools Required . . . . .	2-52
Removal Procedure . . . . .	2-52
Replacement Procedure . . . . .	2-52
A24 40 GHz High Band Coupler (E8244A and E8254A Models Only) . . . . .	2-54
Tools Required . . . . .	2-54
Removal Procedure . . . . .	2-54
Replacement Procedure . . . . .	2-54
A25 20 GHz High Band Detector with A25B Detector Bias Board (E8241A and E8251A Models Only) . . . . .	2-56
Tools Required . . . . .	2-56
Removal Procedure . . . . .	2-56
Replacement Procedure . . . . .	2-56
A25 40 GHz High Band Detector with A25B Detector Bias Board (E8244A and E8254A Models Only) . . . . .	2-58
Tools Required . . . . .	2-58
Removal Procedure . . . . .	2-58
Replacement Procedure . . . . .	2-58
A26 MID (Microcircuit Interface Deck) . . . . .	2-60
Tools Required . . . . .	2-60
Removal Procedure . . . . .	2-60
Replacement Procedure . . . . .	2-60
A27 40 GHz Doubler (E8244A and E8254A Models Only) . . . . .	2-62
Tools Required . . . . .	2-62
Removal Procedure . . . . .	2-62
Replacement Procedure . . . . .	2-62
A28 YIG Oscillator . . . . .	2-64
Tools Required . . . . .	2-64
Removal Procedure . . . . .	2-64
Replacement Procedure . . . . .	2-64



A29 20 GHz Doubler .....	2-66
Tools Required .....	2-66
Removal Procedure .....	2-66
Replacement Procedure .....	2-66
A30 Modulation Filter (Standard and Option 1EA) .....	2-68
Tools Required .....	2-68
Removal Procedure .....	2-68
Replacement Procedure .....	2-68
A31 Motherboard .....	2-70
Tools Required .....	2-70
Removal Procedure .....	2-70
Replacement Procedure .....	2-70
A32 10 MHz Crystal Oscillator (Option UNJ) .....	2-72
Tools Required .....	2-72
Removal Procedure .....	2-72
Replacement Procedure .....	2-72
B1 Fan .....	2-74
Tools Required .....	2-74
Removal Procedure .....	2-74
Replacement Procedure .....	2-74
<b>3. Replaceable Parts</b>	
Ordering Information .....	3-2
Call (800) 227-8164 to Order Parts Fast (U.S. Only) .....	3-2
Save Money with Rebuilt-Exchange Assemblies .....	3-3
Shipping the Defective Assembly Back to Agilent Technologies .....	3-4
Abbreviations Used in Part Descriptions .....	3-5
Major Assemblies .....	3-6
Major Assemblies Top View .....	3-7
Major Assemblies Bottom View .....	3-8
Major Assemblies Microcircuit Deck View .....	3-9
Inside Front Panel View .....	3-10
Main Chassis Top View .....	3-12
Main Chassis Bottom View .....	3-14
Inside Rear Panel View .....	3-16
Microcircuit Interface Deck Top View .....	3-17
MID Bottom View .....	3-18

---

# Contents

Battery-Lithium .....	3-20
Cables .....	3-21
Inside Front Panel View .....	3-22
Main Chassis Top View .....	3-24
Rear Panel View .....	3-26
MID Top View (E8244A and E8254A Models Only) .....	3-28
MID Top View (E8241A and E8251A Models Only) .....	3-30
MID Bottom View .....	3-32
Main Chassis Bottom View .....	3-34
Hardware and Other Instrument Parts .....	3-36
Front Panel View .....	3-37
Disassembled Front Panel View .....	3-38
Disassembled Rear Panel View .....	3-40
Disassembled A32 10 MHz Crystal Oscillator (Option UNJ) .....	3-42
Disassembled AT1 115 dB Attenuator View (Option 1E1) .....	3-43
Disassembled A29 20 GHz Coupler/Detector (E8241A and E8251A Models Only) .....	3-44
Disassembled A24 High Band Coupler and A25 High Band Detector (E8244A and E8254A Models Only) .....	3-45
Microcircuit Interface Deck Top View .....	3-46
Main Chassis and MID Bottom View .....	3-48
2.4 mm RF Output Connector (E8244A and E8254A Models Only) .....	3-50
APC 3.5 RF Output Connector (E8241A and E8251A Models Only) .....	3-51
Type-N RF Output Connector (E8241A and E8251A with Option 1ED Models Only) .....	3-52
Main Chassis with Inside Cover and Right-Side Support Wall .....	3-53
Outer and Inner Instrument Covers and Associated Parts .....	3-54
Miscellaneous .....	3-55
Accessories .....	3-56
Documentation .....	3-56
Electrostatic Discharge (ESD) Protective Supplies .....	3-56
<b>4. Post-Repair Procedures</b>	
Post-Repair Procedures Matrix .....	4-2

**5. Safety and Regulatory**

Safety and Regulatory .....5-2

General Safety Considerations .....5-3

Lithium Battery Disposal .....5-4

Warranty.....5-5

Assistance.....5-6

Notice .....5-7

Certification .....5-8



---

# **1 Troubleshooting**

## Before Troubleshooting

---

**WARNING** These troubleshooting instructions are for use by qualified personal only. To avoid electrical shock, do not perform any troubleshooting unless qualified.

---

**WARNING** The opening of covers or removal of parts is likely to expose dangerous voltages. Disconnect the signal generator from all voltage sources before it is opened.

---

**WARNING** The following techniques related to ESD and static-safe workstations should not be used when working on circuitry with a voltage potential greater than 500 volts.

---

## ESD Information

### Protection from Electrostatic Discharge

Electrostatic discharge (ESD) can damage or destroy electronic components. All work on electronic assemblies should be performed at a static-safe workstation using two types of static-safe workstation protection:

- conductive table-mat and wrist-strap combination
- conductive floor-mat and heel-strap combination

Both types, when used together, provide a significant level of ESD protection. Of the two, only the table-mat and wrist-strap combination provides adequate ESD protection when used alone. To ensure user safety, the static-safe accessories must provide at least 1 meg ohm of isolation from ground.

### Handling of Electronic Components and ESD

---

**CAUTION** Many of the assemblies in this instrument are very susceptible to damage from electrostatic discharge (ESD). Perform troubleshooting procedures only at a static-safe workstation and wear a grounding strap.

---

---

**CAUTION** Always handle printed circuit board assemblies by the edges. This will reduce the possibility of ESD damage to components and prevent contamination of exposed plating.

---

The possibility of unseen damage caused by ESD is present whenever components are transported, stored, or used. The risk of ESD damage can be greatly reduced by close attention to how all components are handled.

- Perform work on all components at a static-safe workstation.
- Keep static-generating materials at least one meter away from all components.
- Store or transport components in static-shielding containers.

## Getting Started with Troubleshooting

Determine the starting point in [Table 1-1](#) to begin troubleshooting.

- Problems should be worked on in the order they are presented in this table.
- Overviews of Self-Test, Synthesis Loop, RF Path and Instrument are found in this chapter. The information in these overviews may help the reader better understand how the signal generator operates and the function of each assembly. Each overview is also intended to be used to troubleshoot the signal generator.

**Table 1-1**

<b>If able to run self-test...</b>	<b>Go to this section...</b>
Run Self-Test	<a href="#">“To Run Self-Test” on page 1-3</a> and refer to <a href="#">“Self-Test Failures and Related Troubleshooting” on page 1-15</a> .
<b>If unable to run self-test, check...</b>	<b>Go to this section...</b>
Power supply failures	<a href="#">“ILT-1 Power Supply Failure and Self-Test” on page 1-4</a>
Temperature-related power supply failures	<a href="#">“ILT-2 Temperature Related Power Supply Failure” on page 1-5</a>
A18 CPU turn-on failures	<a href="#">“ILT-3 A18 CPU Turn-On Test” on page 1-6</a>
Front panel display or keyboard operations	<a href="#">“ILT4 Front Panel Display Troubleshooting” on page 1-9</a>
<b>If other conditions occur...</b>	<b>Go to this section...</b>
Unlocked Conditions	<a href="#">“Troubleshooting Unlocks” on page 1-46</a>
Unleveled Conditions	<a href="#">“Troubleshooting Unlevels” on page 1-49</a>
Adjustment Problems	<a href="#">“Troubleshooting Adjustment Problems” on page 1-53</a>
Performance Test Problems	<a href="#">“Troubleshooting Performance Test Problems” on page 1-56</a>

### To Run Self-Test

1. Press the Utility key.
2. Press the Instrument Info/Help Mode softkey.
3. Press the Self Test softkey.
4. Press the Run Complete Self Test softkey.

## ILT-1 Power Supply Failure and Self-Test

When the signal generator appears to be dead (no display or fan) there is often little evidence that points directly to the cause. This section provides steps and solutions to typical failure modes.

---

**CAUTION** Immediately unplug the signal generator from the ac power line if the unit shows any of the following symptoms:

- Smoke, arcing, or unusual noise from inside the instrument.
- A circuit breaker or fuse on the main ac power line opens.

These potentially serious faults must be corrected before proceeding.

---

### Perform These Power Supply LED Checks

Check the front panel LEDs (located next to the LINE switch) for normal operation in both standby and power-on conditions. Normal operation is indicated as follows:

Power Switch	Yellow LED	Green LED
Standby	On	Off
Power-On	Off	On

If normal operation is not observed, go to the assembly-level troubleshooting section entitled Power Supplies vs. Assemblies Matrix ([Table 1-13 on page 1-18](#)).

#### If the fan does not operate when the instrument is powered on

Go to the assembly level troubleshooting section and use the Power Supplies vs. Assembly Matrix ([Table 1-13 on page 1-18](#)) to verify the fan voltage.

#### If the fan operates when the instrument is powered on

Go to "[ILT-3 A18 CPU Turn-On Test](#)" on page 1-6.



## **ILT-2 Temperature Related Power Supply Failure**

### **Thermal Shutdown**

When a thermal shutdown condition occurs, the front panel green LED and the power supply LEDs will blink until the condition is eliminated. Two thermistors in the signal generator monitor temperature. One is located in the A19 Power Supply and the other is located on the A8 Output. If the thermistor temperature is exceeded, a signal is sent to the A3 Power Switch that shuts down the signal generator. The A19 Power Supply thermistor will shutdown when its temperature exceeds 105 degrees centigrade. The A8 Output thermistor shuts down when its temperature reaches approximately 92 degrees centigrade.

To troubleshoot, do the following:

1. If the fan is working, allow the signal generator to cool down.
2. If the signal generator is still shutting down, remove A8 Output to eliminate one thermistor.
3. If the signal generator is still shutting down, replace the A19 Power Supply.

## ILT-3 A18 CPU Turn-On Test

### A18 CPU Turn-On Test

At turn-on, the A18 CPU is designed to complete a series of operational checks. If all power supply voltages are present and the A18 CPU is working correctly, the operational checks are completed. Errors are reported if the A18 CPU has problems identifying other assemblies or communicating with the backup memory located on the A31 Motherboard.

### Failure Symptoms

- display is not functioning
- CPU fails to complete the turn-on check and does not reach normal LCD operation
- display is not functioning after turn-on
- unable to control signal generator from front panel
- error message is displayed after turn-on

### A2 Display Not Functioning or A2 Display Not Functioning After Turn-on

Refer to [“ILT4 Front Panel Display Troubleshooting”](#) on page 1-9.

### A18 CPU Fails to Complete the Turn-On Check

1. Turn power off and remove outer and inner covers.
2. Turn on power and verify A18 CPU LED DS9 (+3.4 Vdc) and DS10 (+5.2 Vdc) are on. If either of the LEDs are off, check the voltages in [Table1-2](#).

**Table 1-2**

Connector P222	Supply Voltage	Acceptable Range
Pin 45-48, 95-98	+3.4 Vdc	+3.4 0.07 Vdc
Pin 49, 50, 99, 100	+5.2 Vdc	+5.2 0.1 Vdc

3. If the voltages are present on connector P222, turn power off and remove the A18 CPU.
4. Inspect the pins on the A31 Motherboard connector. If the pins look good replace the A18 CPU.
5. If either of the voltages are missing, refer to [“Power Supplies”](#) on page 1-17.
6. If DS9 and DS10 are on, proceed to [“Checking the A18 CPU Voltages”](#) on page 1-7.

### Checking the A18 CPU Voltages

1. With the external and internal covers removed and the signal generator on its side, turn power on and check to see if all the power supply LEDs on the A31 Motherboard are on. If any of the power supply LEDs are not on, refer to [“Power Supplies” on page 1-17](#) to troubleshoot.
2. If all the power supply LEDs on the motherboard are on, check the A18 CPU and A31 Motherboard connector pins for the voltages listed in [Table 1-3](#).

**Table 1-3**

Connector	Supply Voltage	Acceptable Range
P223-2, 22	+5 VA	+5.2 0.16 Vdc
P223-3	-15 V_In	-15 0.45 Vdc
P223-4	+32 V_In	+32 0.96 Vdc
P223-21	+15 V_Standby	+14.85 0.6 Vdc
P223-23	+15 V_In	+15 0.75 Vdc
P223-37	-7 Vdc	-7.0 0.14 Vdc
P223-39	+10 Vdc	+10.2 0.2 Vdc
P223-40	+8 Vdc	+7.95 0.21 Vdc

3. If any main power supply voltage problems are detected, refer to [“Power Supplies” on page 1-17](#).
4. If all power supply voltages are good, replace A18 CPU.

## Verifying the A18 CPU Turn-On Sequence

Verify the A18 CPU turn-on sequence by observing DS1 to DS8 (located along the top) sequence patterns. DS1 to DS8 should match the sequence shown in [Table 1-4](#). Before verifying the turn-on sequence, make sure all switches in the upper left-hand corner of the A18 CPU are in the CLOSED (up) position. If the lights fail to step through the sequence, replace A18 CPU.

**Table 1-4 A18 CPU LED Sequence Table**

Sequence	DS1	DS2	DS3	DS4	DS5	DS6	DS7	DS8
1	X	X	X	X	X	X	X	X
2	0	0	X	0	0	0	0	0
3	X	X	X	0	0	0	0	0
4	0	X	X	X	X	X	X	X
5	0	0	0	0	0	0	0	0
6	X	X	X	X	X	X	X	0
7	0	0	X	X	0	X	0	X
After Preset	0	0	0	0	0	0	0	0

(X) indicates LED is ON, (0) indicates LED is OFF

### No Instrument Control From the Front Panel

Refer to [“ILT4 Front Panel Display Troubleshooting”](#) on page 1-9.

### Error Messages

If error messages are reported after the turn-on check is completed, refer to the Error Messages manual for details.

## ILT4 Front Panel Display Troubleshooting

### Overview

The Front Panel Display Assembly consists of the A1 Keyboard, A2 Display (640 x 320 pixels Liquid Crystal Display), A3 Power Switch, and the A4 Inverter dc to ac). The A4 Inverter turns the A2 Display on and off via control lines received from the A18 CPU. The A4 Inverter also converts the 5.2 Vdc to approximately a 160 Vrms, 40 kHz signal to drive the A2 Display.

The A3 Power Switch contains the power on/off switch, standby LED, and power-on LED. The A3 Power Switch also contains the circuitry to pull the ON\_OFF control line to a TTL low and disable the power supply. Another function of the A3 Power Switch is to route the 8 data bits from the A18 CPU to the A2 Display.

### A2 Display Contrast Controls

There are two contrast hardkeys below the A2 Display. The left up arrow key increases the contrast while the right down arrow key decreases the contrast.

The A2 Display brightness can be adjusted from 50 (high brightness) to 1 (low brightness) using the RPG, arrow keys, or the numeric keypad.

Softkey Location: Utility > Display > Brightness

### A2 Display Tests

There are two screen tests for the A2 Display. The Black Pixel Screen Test will turn the display dark and the White Pixel Screen Test will turn the display bright.

Softkey Location: Utility > Display > More (1 or 2)

To exit the test press any front panel key.

### Symptom: Dark Display

Ensure that the signal generator is powered-on and the front panel green LED is lit. If the green LED is not lit refer to the Power Supply Troubleshooting section in this manual. Press any front panel key to disable the screen saver.

If the A2 Display is still not working, check P12 on the A31 Motherboard for the signals in table 1-8.

**Table 1-5**

Signal	State
P12-1	-5.2 Vdc
P12-3 LIGHT_EN	>3 Vdc
P12-4 VDISP	Brightness=50, VDSP < 50 mVdc Brightness=1, VDSP = 3 Vdc

If the 5.2 Vdc line is bad refer to the Power Supply Troubleshooting section in this manual. If either the LIGHT\_EN or VDISP are bad, check them at P221-16 and P221-55 respectively on the A31 Motherboard. If either signal is bad at P221, then replace the A18 CPU.

If the above signals are good, check the A4 Inverter output. To check the A4 Inverter output, the front panel has to be removed from the chassis frame and laid face down. With CN2-1 (A4W1) open there should be a 160 Vrms 40 kHz signal. If you don't see this signal, replace the A4 Inverter. If the signal is present at the A4 Inverter output, then replace the A2 Display.

### Symptom: Bright Display Without Characters

Ensure that the signal generator is powered-on and the front panel green LED is on. If the green LED is not on refer to “Power Supplies” on page 1-17. If the green LED is lit and the display is still too bright, try adjusting the contrast controls on the front panel. If adjusting the contrast controls has no effect, check the connection of the ribbon cable at J9 of the A3 Power Switch.

If the A2 Display is still too bright, use an oscilloscope to check P11 of the A31 Motherboard for the signals in Table 1-6.

**Table 1-6**

Signal	State
P11-4 VLCD	approx. 21 Vdc
P11-6 LCD_ENABLE_H	>3 Vdc
P11-9, 10, 12, 13, 15, 16, 18, 19, 21, 22, 24, 25, 27, 28, 30, 31, 33, 36, 37, 39, 40	Refer to Pulsing Activity in Figure 1-1.

**Figure 1-1**

LCD\_CLK P11-9, P221-50

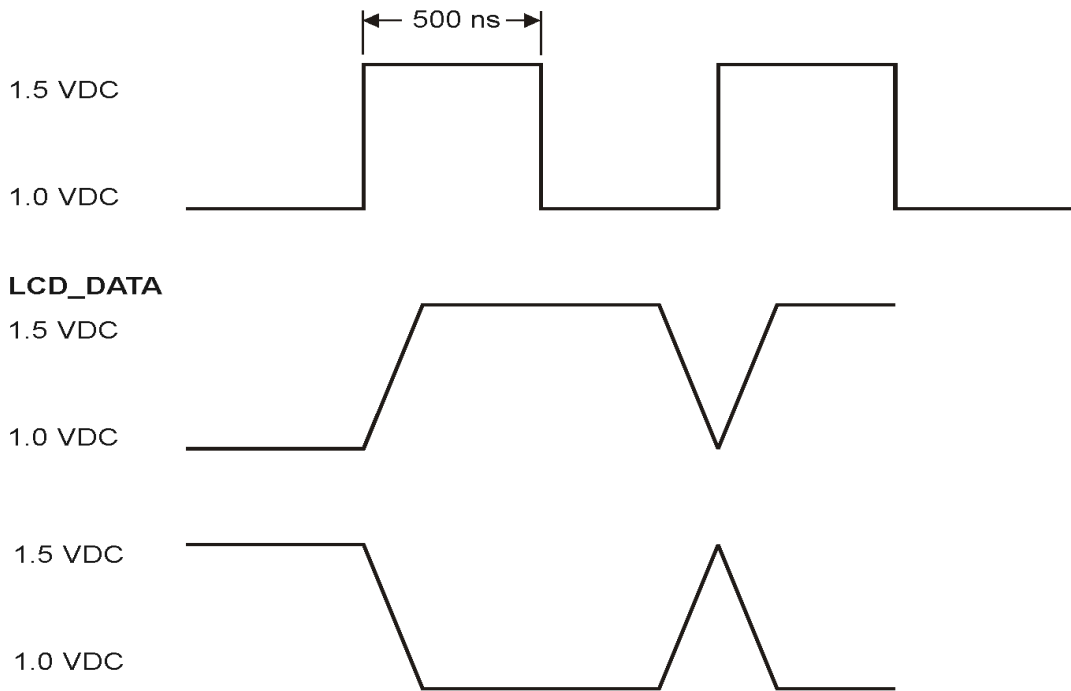

se991A

The pulse state signals listed in [Table 1-6 on page 1-10](#) are control lines, clock, and data for the A2 Display. If any of the above signals are bad, use [Table1-7](#) to check them at P221 of A31 Motherboard. If the signals in [table 1-9](#) are good, then check the signals in [Table1-8](#) at J9 of the A3 Power Switch. To access J9 the front panel must be removed from the chassis frame and laid face down.

**Table 1-7**

Signal	State
P221-14 VLCD	approx. 21 Vdc
P221-53 LCD_ENABLE_H	>3 Vdc
P221-1 to 13, 15, 41, 43, 45, 47, 49 to 52	Refer to Pulsing Activity in <a href="#">Figure 1-1 on page 10</a> .

If any signals in [Table1-7](#) are bad, replace the A18 CPU.

**Table 1-8**

Signal	State
J9-7 VLCD	approx. 21 Vdc
J9-4 LCD_ENABLE_H	>3 Vdc
J9-5	5.2 Vdc
J9-1, 2, 3, 8 to 15	Refer to Pulsing Activity in <a href="#">Figure 1-1 on page 10</a> .

If the signals in [Table1-8](#) are good, then replace A2 Display. If the signals are not good, then replace A3 Power Switch.

## Symptom: Hardkeys or Softkeys Not Functioning

Ensure that the signal generator is powered-on and the front panel green LED is on. If the green LED is not on refer to “Power Supplies” on page 1-17 for troubleshooting. Ensure the signal generator is not being controlled remotely by pressing the Local hardkey

The A1 Keyboard contains the switches for the hardkeys and softkeys. The keys are arranged in a matrix with the control lines KEYCOLx and KEYROWx on the x and y axis. When a hardkey or softkey is pressed, one cell of the matrix is activated. The normally TTL low KEYROWx of the active cell will pulse high and the normally TTL high KEYCOLx of the active cell will pulse low. See Table1-9 for hardkey and softkey matrix locations.

**Table 1-9**

	KEYCOL0	KEYCOL1	KEYCOL2	KEYCOL3	KEYCOL4	KEYCOL5	KEYCOL6	KEYCOL7
KEYROW0	softkey 3	N/A	Cont Up	N/A	N/A	N/A	N/A	N/A
KEYROW1	softkey 2	Incr/Set	Cont Down	Ampl	N/A	AM	Pulse	Utility
KEYROW2	softkey 3	Up	N/A	Freq	N/A	FM/φM	N/A	N/A
KEYROW3	softkey 4	N/A	N/A	Right Arrow	Help	Save	Recall	Trigger
KEYROW4	softkey 6	N/A	Local	Hold	Mod On/Off	4	5	6
KEYROW5	softkey 5	N/A	Return	Down Arrow	N/A	7	8	9
KEYROW6	N/A	N/A	N/A	Left Arrow	RF On/Off	0	.	+/-
KEYROW7	softkey 7	N/A	Preset	N/A	N/A	1	2	3



If a front panel hardkey or softkey is not functioning, use an oscilloscope to monitor the KEYCOLx and KEYROWx pins at P13 on the A31 Motherboard. Use [Table 1-10](#) to identify the appropriate pin number. The KEYROW pin should be a TTL low and the KEYCOL pin should be a TTL high. If either signal is incorrect, use [Table 1-11](#) and check the signal at P221 as it leaves the A18 CPU. If the signal is bad at P221, then replace the A18 CPU. If both signals are correct, then press the faulty hardkey or softkey while monitoring the KEYCOL or KEYROW on the oscilloscope. The KEYCOL line should pulse low, while the KEYROW line should pulse high. If either line is not functioning properly then replace the A1 Keyboard.

**Table 1-10**

KEYCOL0	P13-1
KEYCOL1	P13-3
KEYCOL2	P13-5
KEYCOL3	P13-7
KEYCOL4	P13-9
KEYCOL5	P13-11
KEYCOL6	P13-13
KEYCOL7	P13-15
KEYROW0	P13-17
KEYROW1	P13-19
KEYROW2	P13-21
KEYROW3	P13-23
KEYROW4	P13-25
KEYROW5	P13-26
KEYROW6	P13-24
KEYROW7	P13-22

**Table 1-11**

KEYCOL0	P13-1
KEYCOL1	P13-3
KEYCOL2	P13-5
KEYCOL3	P13-7
KEYCOL4	P13-9
KEYCOL5	P13-11
KEYCOL6	P13-13
KEYCOL7	P13-15
KEYROW0	P13-17
KEYROW1	P13-19
KEYROW2	P13-21
KEYROW3	P13-23
KEYROW4	P13-25
KEYROW5	P13-26
KEYROW6	P13-24
KEYROW7	P13-22

### **Symptom: RPG Knob Not Functioning**

Ensure that the signal generator is powered-on and the front panel green LED is on. If the green LED is not on refer to [“Power Supplies” on page 1-17](#) for troubleshooting. When the RPG is functioning properly DS1 on the A18 CPU will blink when the RPG knob is rotated.

Check P13-12 for +5.2 Vdc. If the voltage is not present, refer to [“Power Supplies” on page 1-17](#) for troubleshooting. Press the Frequency hardkey on the front panel. Using an oscilloscope monitor P13-14 and P13-10 while rotating the RPG knob. The display frequency value should change and both signals at P13 should pulse to a TTL high. If either signal does not pulse then replace the A1 Keyboard.

If the signals are pulsing at P13 then check the signal at P221 pins 57 and 17 of the A31 Motherboard. If the signals are pulsing, replace the A18 CPU.

### **Symptom: Screen Saver Not Functioning**

The screen saver delay may be set for any integer from 1 to 12 hours. The A18 CPU controls the screen saver by pulling the LIGHT\_EN line low. If the delay time has elapsed and the display hasn't gone dark, check the LIGHT\_EN signal at P12-3. If the signal is a TTL low then replace the A4 Inverter. If the signal is a TTL high, then check it at P221-16 of the A31 Motherboard. If the signal is high at P221, replace the A18 CPU.

## Self-Test Failures and Related Troubleshooting

This section has a two column table: one column has self-test errors and a second column has a list of sections to go for assembly level troubleshooting procedures.

**Table 1-12 Self-Test Failures and Related Troubleshooting**

<b>If a self-test for this assembly fails...</b>	<b>Go to this assembly troubleshooting section...</b>
A5 Sampler 200 Power Supply 201 Tuning + Bias Test 202 Coarse Loop Detector 203 YO Loop Detector	<a href="#">“Self-Tests 2xx: A5 Sampler Self-Test Errors” on page 1-24</a>
A7 Reference 300 1 GHz Detector 301 Tuning Voltage	<a href="#">“Self-Tests 3xx: A7 Reference (Standard) Self-Test Errors” on page 1-26</a>
A8 Output 400 Lowband Ground and PTAT Test 401 Prelevel Loop Test 402 Switching Filter Test 403 ALC Mod System Test 404 Mod System Test 405 Het Band Test 406 RF Path Test	<a href="#">“Self-Tests 4xx: A8 Output Self-Test Errors” on page 1-27</a>
A9 YIG Driver 600 Post Regulator 601 DACs 602 PLL Regulators 603 FM Driver	<a href="#">“Self-Tests 6xx: A9 YIG Driver Self-Test Errors” on page 1-29</a>
A6 Frac-N 700 Ref Voltage 701 Loop Gain 702 Tuning Voltage 703 Output Voltage 704 Filter Test 705 F/2 Test 706 FM Path Test	<a href="#">“Self-Tests 7xx: A6 Frac-N Self-Test Errors” on page 1-31</a>

**Table 1-12 Self-Test Failures and Related Troubleshooting**

<b>If a self-test for this assembly fails...</b>	<b>Go to this assembly troubleshooting section...</b>
A10 ALC 900 Power Supply 901 Detector Test 902 Detector Level to ALC Ref 903 Level Test	<a href="#">“Self-Tests 9xx: A10 ALC Self-Test Errors” on page 1-34</a>
A7 Reference (Option UNJ) 1000 Power Supply 1001 10 MHz Test 1002 1 GHz Test	<a href="#">“Self-Tests 10xx: A7 Reference (Option UNJ) Self-Test Errors” on page 1-36</a>
A18 CPU 1100 Power Supply	<a href="#">“Self-Tests 11xx: A18 CPU Self-Test Errors” on page 1-38</a>
A26 Micro Interface Deck 1200 Mod Filter 1201 20 GHz Doubler 1202 40 GHz Doubler 1203 RF Path	<a href="#">“Self-Tests 12xx: A26 MID Self-Test Errors” on page 1-40</a>
A11 Pulse/Analog Modulation Generator 1300 Power Supply 1301 Internal Pulse Generator Clock 1302 Output 1303 Voltage Ref DAC 1304 20 GHz Pulse 1305 40 GHz Pulse 1306 Standard 3 GHz Pulse 1307 High Performance 3 GHz Pulse 1308 Numeric Synthesizer 1309 Function Generator Channel 1 1310 Function Generator Channel 2 1311 Frequency Modulator 1312 Low Frequency Out 1313 Amplitude Modulation 1314 External 1 1315 External 2	<a href="#">“Self-Tests 13xx: A11 Analog/Pulse Modulation Generator Self-Test Errors” on page 1-43</a>

---

## Troubleshooting Assembly Level Problems

### Power Supplies

The power supply is a switching supply that has an automatic line-voltage and frequency selection. There are no switches to change for 115 Vac or 240 Vac operation. The power line fuse is not replaceable. If the fuse opens, the power supply must be replaced. Use the Power Supplies vs. Assembly Matrix (Table 1-13 on page 1-18) to troubleshoot the signal generator's power supplies.

---

**WARNING**    **Wait 30 seconds after unplugging the instrument to allow the supplies to discharge before removing or installing any assemblies.**

---

**Table 1-13 Power Supplies vs. Assembly Matrix (1 of 3)**

<b>Motherboard test points for:</b>	<b>+32 Vdc</b>	<b>+15 Vdc</b>	<b>+10 Vdc</b>	<b>+8 Vdc</b>	<b>+9 Vdc</b>	<b>+5.2 Vdc</b>
A1 Keyboard						P13-2
A2 Display						P11-44
A2DS1 Backlight						
A3 Power Supply	P231-1,4	P231-3,4,43,44	P231-6,7,46,47			P231-15,18,19,55,56,58,59
A5 Sampler	P22-7	P22-6,21			P22-20,5	P22-14,29
A6 Frac-N	P32-7	P32-6,21			P32-20,5	P32-14,29
A7 Reference	P42-7	P42-6,21			P42-20,5	P42-14,29
A8 Output	P52-7	P52-6,21			P52-20,5	P52-14,29
A9 YIG Driver	P112-6	P112-5,30	P112-15,16,40		P112-17,18,42	P112-17,18,42
A10 ALC	P122-4	P122-28				
A11 Mod Gen	P132-4	P132-28				
A18 CPU	P223-4	P223-23	P223-39	P223-40	P223-9	P223-9
A21 Rear Panel		P241-17,18	P241-17,18			P241-11,12
Microwave Interface	P201-1	P201-2,3,4	P201-5,6,7,8,9,10	P201-29		P201-13,14,15,16,17,18
<b>Microcircuit test points for:</b>						
AT1		J13-1				
A23 Low Band Coupler/Detector		J15-8				J115-12
A27 40 GHz Doubler		J36-5, J33-5	J36-19 J33-19	J36-21 J33-21		J36-7,9
A29 20 GHz Doubler		J32-5	J32-19	J32-21		J32-7,9
A30 Mod Filter		J31-5	J31-19	J31-21		J31-7,9

**Table 1-14 Power Supplies vs. Assembly Matrix (2 of 3)**

<b>Motherboard test points for:</b>	<b>+5.2 Digital</b>	<b>+3.4 Digital</b>	<b>+2.6 Vdc</b>	<b>-7 Vdc</b>	<b>-6 Vdc</b>
A1 Keyboard					
A2 Display	P12-1				
A2DS1 Backlight	P12-1				
A3 Power Supply	P231-21,22,2561,62,65,	P231-28,29,32,35,36,68,69,72,75,76		P231-9,10,49,50	
A5 Sampler					PP22-3,18
A6 Frac-N					P32-3,18
A7 Reference					P42-3,18
A8 Output					P52-3,18
A9 YIG Driver	P111-64,65,129,130	P111-60,61,62,63,125,126,127,128	P112-57,58,59,123,124	P112-11,12,13,14,38	P112-19,44
A10 ALC	P122-64,65,129,130	P122-60,61,62,63,125,126,127,128	P122-57,58,59,123,124		
A11 Mod Gen	P132-64,65,129,130	P132-60,61,62,63,125,126,127,128	P132-57,58,59,123,124		
A18 CPU	P222-49,50,99,100	P222-45,46,47,48,95,96,97,98		P223-37	P223-3
A21 Rear Panel					
Microwave Interface	P201-23	P201-24		P201-30,33,46	
<b>Microcircuit test points for:</b>					
AT1		J13-2			
A23 Low Band Coupler/Detector					
A27 40 GHz Doubler					
A29 20 GHz Doubler					
A30 Mod Filter					

**Table 1-15 Power Supplies vs. Assembly Matrix (3 of 3)**

<b>Motherboard test points for:</b>	<b>-15 Vdc</b>	<b>-5.2 Vdc</b>	<b>+12 Vdc</b>	<b>+15 Vdc stby</b>	<b>Fan Voltage</b>
A1 Keyboard					
A2 Display				P11-43	
A2DS1 Backlight					
A3 Power Supply	P231-12,13,52,53			P231-80	
A5 Sampler	P22-2	P22-4-19			
A6 Frac-N	P32-2	P32-4,19			
A7 Reference	P42-2	P42-4,19			
A8 Output	P52-2	P52-4,19			
A9 YIG Driver	P112-4,29	P112-1,2,26,27			
A10 ALC	P122-3	P122-1-26			
A11 Mod Gen	P132-3	P132-1,26			
A18 CPU	P223-3	P223-1		P223-21	
A21 Rear Panel	P241-15,16	P241-9,10		P241-5,6,7,8	
Microwave Interface	P201-11,12	P201-31,32			
<b>Microcircuit test points for:</b>					
AT1					
A23 Low Band Coupler/Detector	J15-10				
A27 40 GHz Doubler	J36-4, J33-4				
A29 20 GHz Doubler	J32-4	J32-8	J32-1,3		
A30 Mod Filter	J31-4	J31-8	J31-1,3		
Fan					P6-2



**Amber Standby LED not working**

With the power turned off, and the signal generator plugged in, the front panel amber standby LED and the +15 Vdc standby LED on the motherboard should be on. The amber Standby LED is controlled by a +15 Vdc standby line supplied by the power supply, which is routed through the motherboard to the front panel.

To troubleshoot the +15 Vdc Standby line, turn the signal generator off and refer to the Power Supply vs. Assembly Matrix (Table 1-13 on page 1-18) to follow the signal path.

**Green Line Power LED not working**

When the power switch is turned on, the amber LED will go out and the green LED will come on. The fan will start rotating and the front panel display will become illuminated.

To troubleshoot, refer to the Power Supplies vs. Assembly Matrix (Table 1-13 on page 1-18) to verify the power supply voltages at P11 of the A31 Motherboard. If the supply voltages are correct, replace the A3 Power Switch.

**Fan not working**

The fan is connected to the rear panel assembly and is audible when the signal generator is powered on. The fan voltage is temperature dependent. At room temperature, the fan will race at power up and then stabilize after a few seconds to a fan voltage of approximately +8.6 volts. At higher temperatures, the fan voltage will increase along with the rotation of the fan.

To troubleshoot, disconnect the fan from the rear panel assembly at P6 and check the fan voltage at P6-2 on the rear panel assembly. If the fan voltage is correct, replace the B1 Fan.

**Signal Generator does not power-up and the power supply LEDs not working**

Each of the power supplies has an LED located on the bottom of the A31 Motherboard. If the power supply is functioning, the green LED will be on. Use a voltmeter to measure the supplies on the A31 Motherboard to ensure the voltages meet the power supply specification in Table 1-16.

**Table 1-16**

Power Supply	Acceptable Voltage
+32 Vdc	32 ± 1 Vdc
+15 Vdc	15 ± .5 Vdc
+15 Vdc Standby	15 ± .75 Vdc
+10 Vdc	10.2 ± .2 Vdc
+5.2 Vdc	5.2 ± 0.15 Vdc
+5.2 Digital high	5.2 ± 0.15 Vdc
+3.4 Digital low	3.4 ± 1 Vdc
-7.0 Vdc	-7 ± 0.1 Vdc
-15 Vdc	-15 ± 0.5 Vdc

With the exception of the +15 Vdc Standby supply, each supply should have a maximum of 10 mV<sub>p-p</sub> ripple. The +15 Vdc Standby supply has a maximum ripple specification of 20 mV<sub>p-p</sub>. The ripple may be measured using an oscilloscope.

If any of the supplies LEDs are not on or the measured voltage is less than the acceptable value, one the

assemblies may be loading down the supply. Refer to the Power Supply vs. Assembly Matrix (Table 1-13 on page 1-18) to find out where each supply is being used. To isolate the defective assembly, power down the signal generator and remove one of the assemblies being biased by the faulty supply.

---

**NOTE**      **It is important to have only a minimum number of assemblies removed at one time. The power supply expects to see a minimum load, otherwise the supply voltage will increase until an overvoltage condition exists.**

---

Turn the signal generator ON and check the faulty supply. If it is still bad, power down the signal generator and re-install the first assembly removed. Remove the next assembly and see if the problem is alleviated. Continue this process until the supply is functioning properly. Replace the last assembly that was removed.

#### **Power Switch On/OFF Line**

If the control line (ON/OFF) from the A3 Power Switch located in the front panel goes to a TTL low state or if the line impedance is less than 500 ohms, the power supply will shutdown. This signal can be measured on the A31 Motherboard at pin 79 of P241.

To troubleshoot, turn the front panel switch on. Make sure the +15 Vdc Standby voltage is good. The ON\_OFF control line should be >3.5 Vdc. The A3 Power Switch located in the front panel controls this signal.

#### **Front Panel Green LED Not Working and Power Supply LEDs on Motherboard Not Blinking**

##### **Overvoltage or Overcurrent Conditions**

The individual supplies in the signal generator are not fused but do have the capability of shutting down if an overvoltage condition exists. When either of these conditions exist, the front panel green LED and the power supply LEDs blink at approximately a 2 Hz rate. The power supply is attempting to revive itself but if the overvoltage or overcurrent condition hasn't cleared, the signal generator will remain in this mode. In some cases, the condition may be cleared by cycling the power off and on.

To troubleshoot, isolate the defective assembly by powering down the signal generator and removing one of the assemblies being biased by the faulty supply.

---

**NOTE**      **It is important to have only a minimum number of assemblies removed at one time. The power supply expects to see a minimum load, otherwise the supply voltage will increase until an overvoltage condition exists.**

---

Turn the signal generator ON and check whether the overvoltage or overcurrent condition still exists. If it is still bad, power down the signal generator and re-install the first assembly removed. Remove the next assembly and see whether the problem is alleviated. Continue this process until the supply is functioning properly. Replace the last assembly that was removed.

### **LEDs for +9, -6 or -5.2 Vdc Power Supplies Not Working**

These supplies are generated on the A9 YIG Driver.

To troubleshoot, make sure the A9 YIG Driver is receiving the +32, +15, +10, -7, -15 Vdc supplies. These can be measured at P112 on the A31 Motherboard. Refer to the Power Supplies vs. Assembly Matrix ([Table 1-13 on page 1-18](#)) for pin numbers.

If the supplies are present at P112, use the Power Supplies vs. Assembly Matrix ([Table 1-13 on page 1-18](#)) to find out where each supply is being used. To isolate the defective assembly, power down the signal generator and remove one of the assemblies being biased by the faulty supply. Power the signal generator up again and check the faulty supply. If the supply is still bad, power down the signal generator and re-install the first assembly removed. Remove the next assembly and see if the problem is alleviated. Continue this process until the supply is functioning properly. Replace the last assembly that was removed.

## Self-Tests 2xx: A5 Sampler Self-Test Errors

Figure 1-2

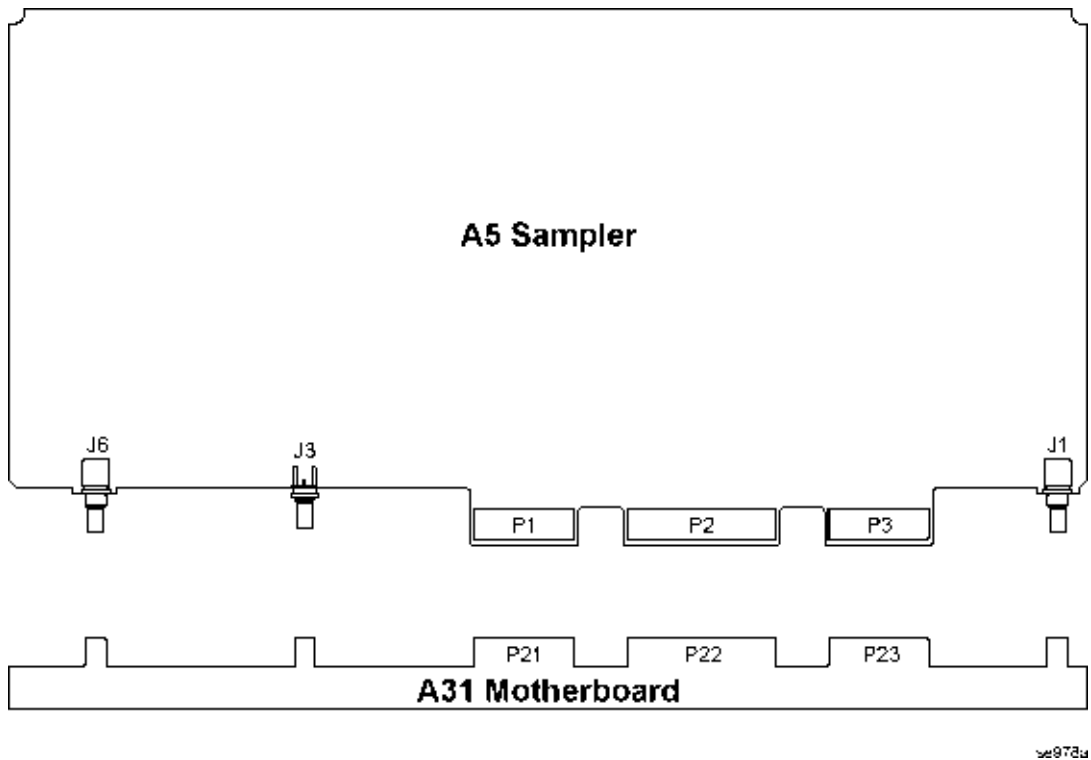

Before proceeding to the reported self-test error code, check the voltages in [Table 1-17](#). If any voltages are out of specification troubleshoot the supply problem first.

Table 1-17

Supply Voltage (Vdc)	Connector Pins	Minimum Value (Vdc)	Maximum Value (Vdc)	Origin
+32	P22-7	+31.04	+32.96	Main Supply
+15	P22-6, 21	+14.55	+15.45	Main Supply
-15	P22-2, 17	-14.55	-15.45	Main Supply
+5.2	P22-14, 29	+5.04	+5.37	Main Supply
+9	P22-5, 20	+8.82	+9.18	YIG Driver

### 200 Power Supply

1. If the supply voltages are good on the connector pins indicated, replace the A5 Sampler.
2. If the supply voltages are bad on any of the connector pins indicated, check the origin of the supply.
3. If the supply voltages are good at the origin, replace the A31 Motherboard.
4. If the supply voltages are bad at the origin, troubleshoot the problem using that assembly's

troubleshooting procedure.

### **201 Tuning + Bias Test**

1. Turn power off and remove the A5 Sampler and connect a signal analyzer to the A5 Sampler J1 input cable on the A31 Motherboard.
2. Turn the signal generator on and check for the presence of a 1 GHz signal at the level of 0 dBm.
3. If the signal is good on the cable connector J1, replace the A5 Sampler.
4. If the signal is bad, remove the A7 Reference and ohm the cable between the center pins (a short should occur) and between the center pins and shielding (an open should occur) of J3 on the A7 Reference and J1 on the A5 Sampler.
5. If an open is measured between the center pins or a short between center pins and the shielding, replace the cable.
6. If the cable is good, replace the A7 Reference.

### **202 Coarse Loop Detector**

1. Replace the A5 Sampler

### **203 YO Loop Detector**

1. With power on carefully remove the A5 Sampler, connect a signal analyzer to J3 on the A31 Motherboard. Set the signal generator to 8 GHz CW then check for an 8 GHz signal at a power level greater than or equal to -7 dBm on J3.
2. If the J3 signal is bad, troubleshoot the A29 20 GHz Doubler using the procedure in the RF path section. If the J3 signal is good, go to the next step.
3. Connect the signal analyzer to the A6 Frac-N VCO signal on the J6 connection on the A31 Motherboard. With the signal generator set to 8 GHz CW, the A6 Frac-N signal should be at a frequency of 593.75 MHz and at a power level of +7 dBm.
4. If the signal is good, replace the A5 Sampler, if the signal is bad go to the A6 Frac-N troubleshooting procedure.

## Self-Tests 3xx: A7 Reference (Standard) Self-Test Errors

Figure 1-3

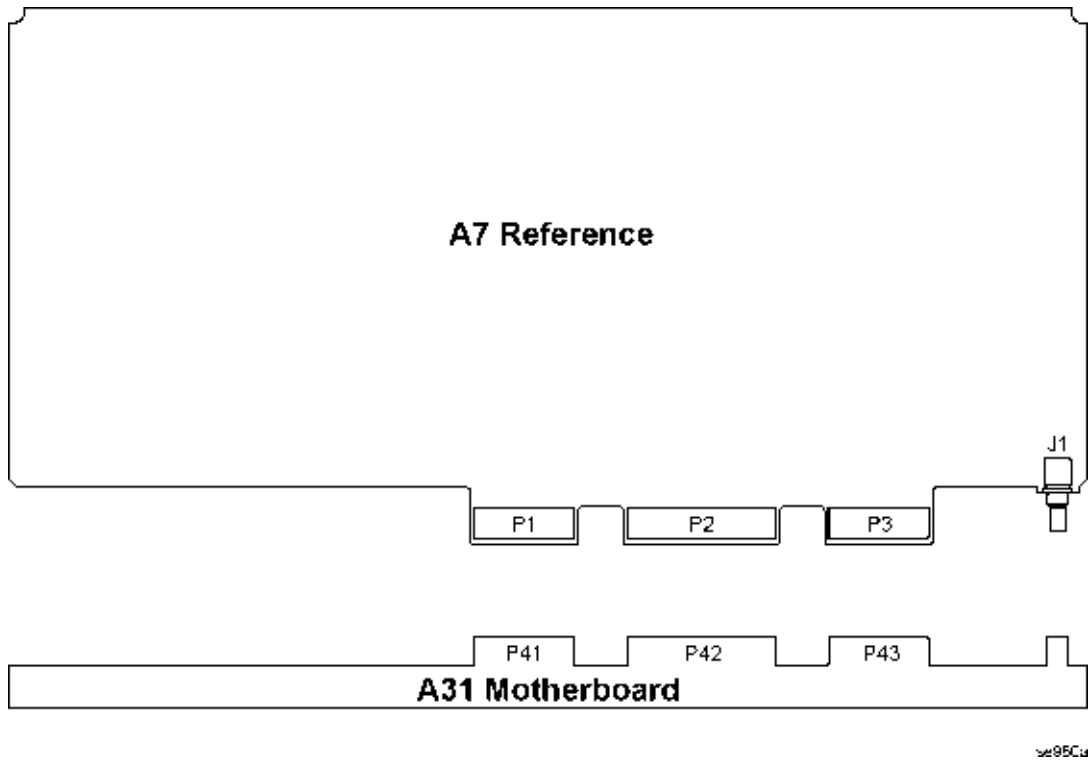

Before proceeding to the reported self-test error code, check the voltages in [Table 1-18](#). If any of the voltages are out of specification troubleshoot the supply problem first.

Table 1-18

Supply Voltage (Vdc)	Connector Pins	Minimum Value (Vdc)	Maximum Value (Vdc)	Origin
+32	P102-7	+31.04	+32.96	Main Supply
+15	P102-6, 21	+14.55	+15.45	Main Supply
-15	P102-2, 17	-14.55	-15.45	Main Supply
+5.2	P102-14, 29	+5.04	+5.37	Main Supply
+9	P102-5, 20	+8.82	+9.18	YIG Driver

### 300 1 GHz Detector

1. Check and remove any connection to the 10 MHz external reference on the rear panel.
2. If the signal generator continues to fail self-test, replace the A7 Reference.

### 301 Tuning Voltage

1. Replace the A7 Reference.

## Self-Tests 4xx: A8 Output Self-Test Errors

Figure 1-4

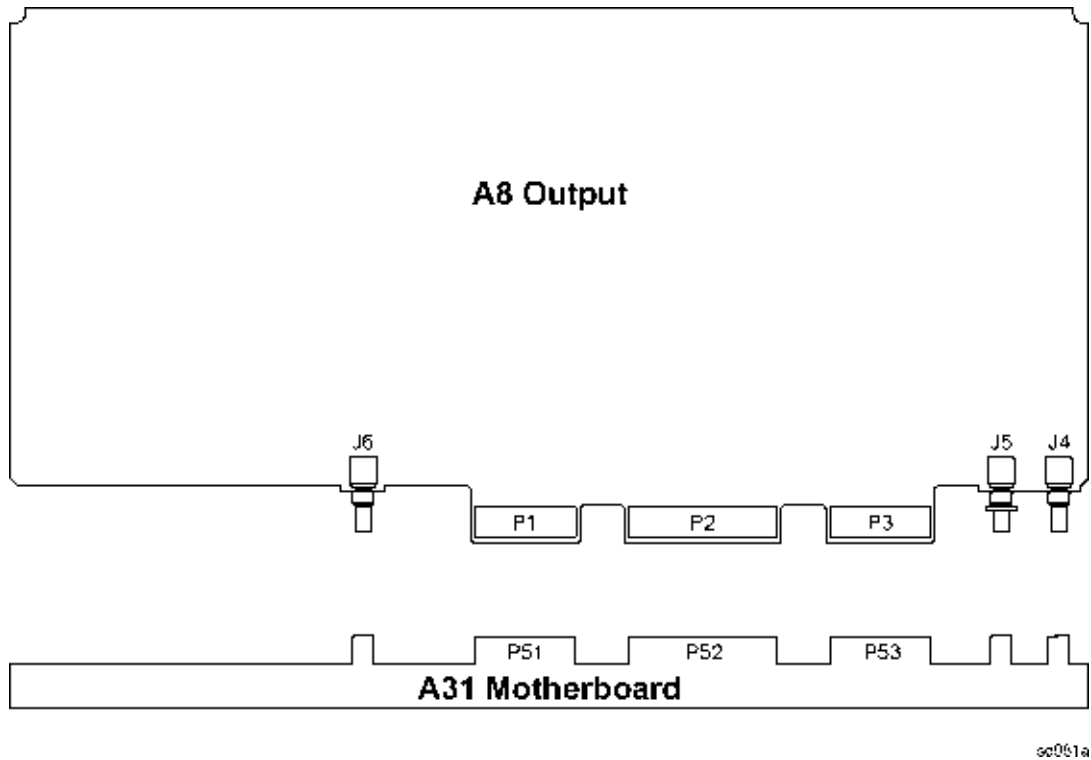

Before proceeding to the reported self-test error code, check the voltages in [Table 1-19](#). If any voltages are out of specification troubleshoot the supply problem first.

Table 1-19

Supply Voltage (Vdc)	Connector Pins	Minimum Value (Vdc)	Maximum Value (Vdc)	Origin
+15	P52-6, 21	+14.55	+15.45	Main Supply
-15	P52-2, 17	-14.55	-15.45	Main Supply
+5.2	P52-14, 29	+5.04	+5.36	Main Supply
+9	P52-5, 20	+8.82	+9.18	YIG Driver
-6	P52-3, 18	-5.88	-6.12	YIG Driver

### 400 Ground and PTAT Test

1. Replace A8 Output.

### 401 Prelevel Loop Test

1. With the signal generator powered up carefully remove the A8 Output. Set the signal generator to 3 GHz CW. Connect a spectrum analyzer to the A6 Frac-N RF output at J4 of the A8 Output. The signal at J4

should be at 3 GHz and  $\geq 0$  dBm.

2. If the signal is not present or at the correct level, replace the Frac-N.
3. If the signal is present, replace the A8 Output.

---

**WARNING** Don't re-install the A8 Output with the signal generator powered up. This could cause serious damage to the signal generator.

---

#### **402 Switching Filter Test**

1. Replace the A8 Output.

#### **403 ALC Mod System Test**

1. Replace the A8 Output.

#### **404 Pulse Mod System Test**

1. Replace the A8 Output.

#### **405 RF Path Test**

1. Replace the A8 Output.



## Self-Tests 6xx: A9 YIG Driver Self-Test Errors

Figure 1-5

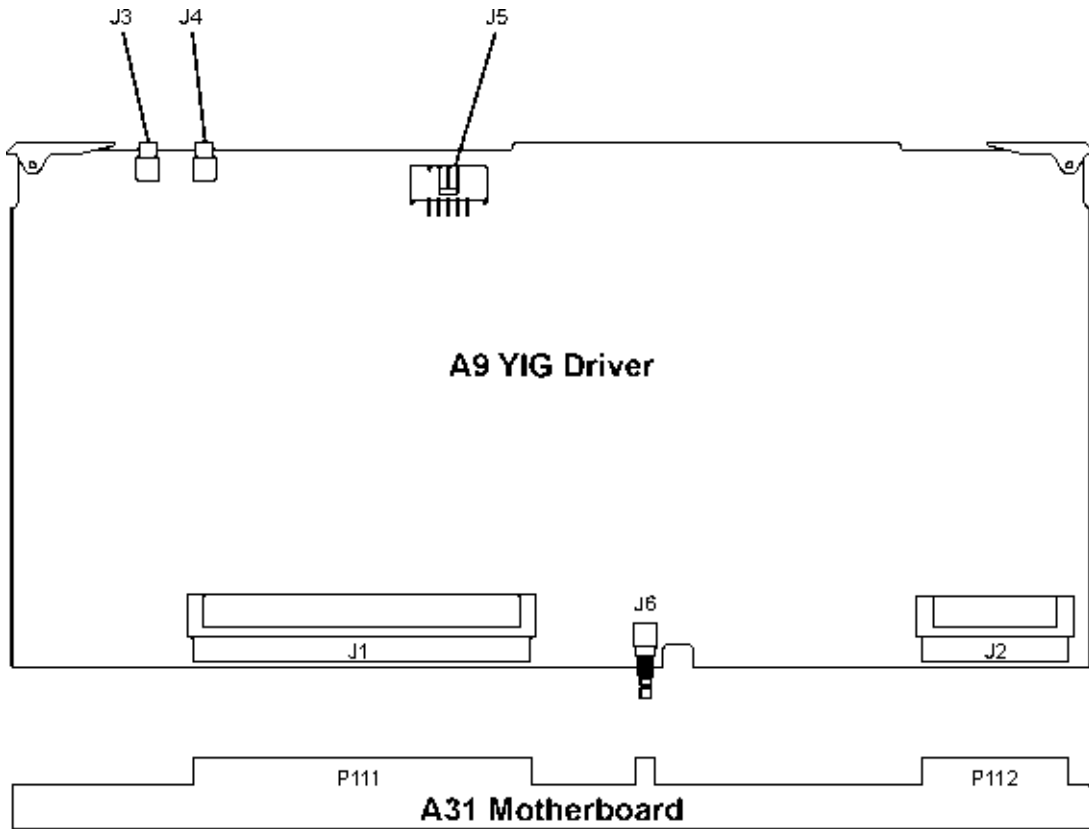

se952a

Before proceeding to the reported self-test error code, check the voltages in [Table 1-20](#). If any voltages are out of specification troubleshoot the supply problem first.

Table 1-20

Supply Voltage (Vdc)	Connector Pins	Minimum Value (Vdc)	Maximum Value (Vdc)	Origin
+32	P112-6	+31.04	+32.96	Main Supply
+15	P112-5, 30	+14.55	+15.45	Main Supply
-15	P112-4, 29	-14.55	-15.45	Main Supply
+5.2	P112-3, 28	+5.04	+5.37	Main Supply
+10	P112-15, 16, 40	+10	+10.4	Main Supply
-7	P112-11, 12, 13, 14, 30	-6.86	-7.14	Main Supply
+5.2 Digital high	P111-64, 65, 129, 130	+5.04	+5.36	Main Supply

**Table 1-20**

Supply Voltage (Vdc)	Connector Pins	Minimum Value (Vdc)	Maximum Value (Vdc)	Origin
+3.4 Digital Low	P111-60, 61, 62, 63, 125, 126, 127, 128	+3.29	+3.5	Main Supply

**A9 YIG Driver Output Voltages**

If any of the voltages in [Table1-21](#) are out of specification, replace the A9 YIG Driver.

**Table 1-21**

Supply Voltage (Vdc)	Connector Pins	Minimum Value (Vdc)	Maximum Value (Vdc)
+9	P112-17, 18, 42	+8.82	+9.18
-5.2	P112-1, 2, 26, 27	-5.1	-5.3
-6	P112-19, 44	-5.88	-6.12

**600 Post Regulator**

1. Replace the A9 YIG Driver.

**601 DACs**

1. Replace the A9 YIG Driver.

**602 PLL Interface**

1. Remove the cable from the A5 Sampler to J4 on the A9 YIG Driver.
2. Loop self-test 602 and using an oscilloscope measure the voltage on J4. The voltage should pulse to +10 Vdc.
3. If the voltage is +10 Vdc, replace the A9 YIG Driver.
4. If the voltage on J4 is bad, replace the A5 Sampler.

**603 FM Driver**

1. Remove the cable from the A6 Frac-N to J3 on the A9 YIG Driver.
2. Loop self-test 603 and using an oscilloscope measure the voltage on J3. The voltage should be approximately -1.3 Vdc.
3. If the voltage is approximately -1.3 Vdc, replace the A9 YIG Driver.
4. The voltage on J3 originates on the A11 Pulse/Analog Modulation Generator and passes through the A6 Frac-N. If the voltage is bad at J3 check it entering the A6 Frac-N at P31-11. If the voltage is bad, troubleshoot the A11 Pulse/Analog Modulation Generator. If the voltage is good entering the A6 Frac-N, then troubleshoot the Frac-N.

## Self-Tests 7xx: A6 Frac-N Self-Test Errors

Figure 1-6

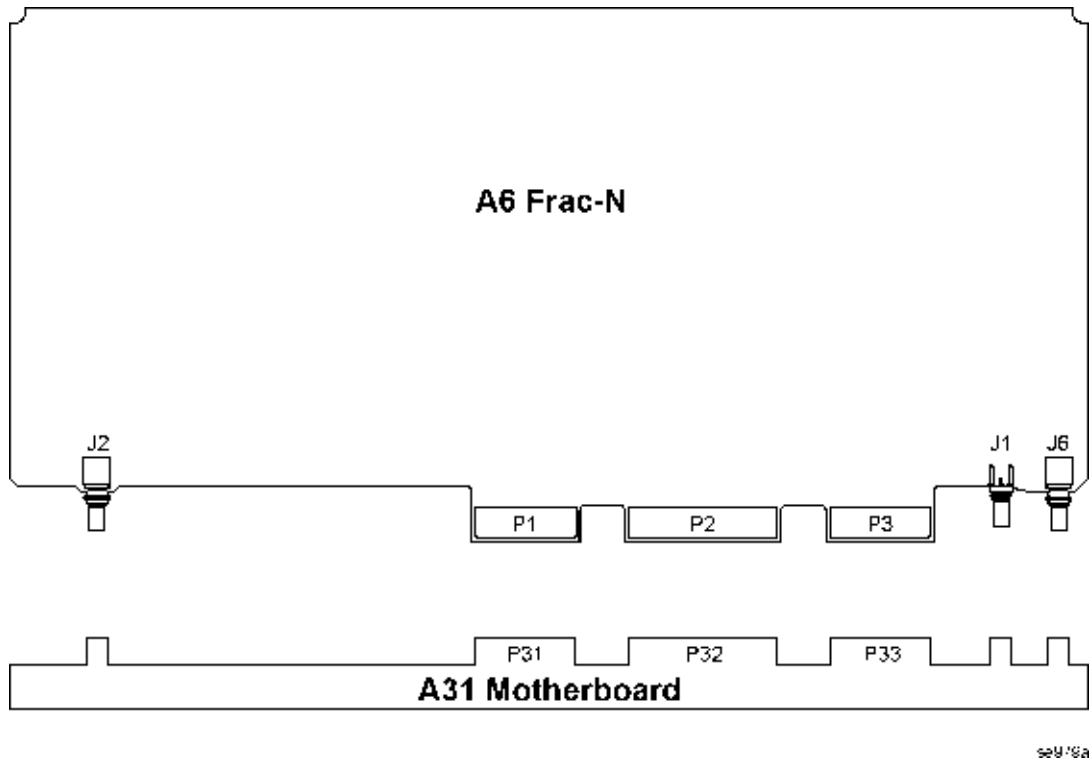

Before proceeding to the reported self-test error code, check the voltages in [Table 1-22](#). If any voltages are out of specification troubleshoot the supply problem first.

Table 1-22

Supply Voltage (Vdc)	Connector Pins	Minimum Value (Vdc)	Maximum Value (Vdc)	Origin
+32	P32-7	+31.04	+32.96	Main Supply
+15	P32-6, 21	+14.55	+15.45	Main Supply
-15	P32-2, 17	-14.55	-15.45	Main Supply
+5.2	P32-14, 29	+5.04	+5.37	Main Supply
+9	P32-5, 20	+8.82	+9.18	YIG Driver
-5.2	P32-4, 19	-5.1	-5.3	YIG Driver
-6	P32-3, 18	-5.88	-6.12	YIG Driver

### 700 Ref Voltage

1. Replace the A6 Frac-N.

### 701 Loop Gain

1. Replace the A6 Frac-N.

### 702 Tuning Voltage

1. Check 10 MHz Synthesis line on P33-15 using an oscilloscope. The signal period should be 100 ns with an amplitude of approximately 3 V<sub>p-p</sub>.
2. If the signal is good, replace the A6 Frac-N.
3. If the signal is bad, turn the signal generator power off and remove the A6 Frac-N. Measure the P33-15 again.
4. If the signal is good, replace the A6 Frac-N, if the signal is still bad, measure P41-5 on the A7 Reference. If the signal is good, at P41-5, replace the A31 Motherboard.
5. If the signal is bad on P41-5, replace the A7 Reference.

### 703 Output Voltage

1. Check 10 MHz Synthesis line on P33-15 using an oscilloscope. The signal period should be 100 ns with an amplitude of approximately 3 V<sub>p-p</sub>.
2. If the signal is good, replace the A6 Frac-N.
3. If the signal is bad, turn the signal generator power off and remove the A6 Frac-N. Measure the P33-15 again.
4. If the signal is good, replace the A6 Frac-N, if the signal is still bad, measure P41-5 on the A7 Reference. If the signal is good, at P41-5, replace the A31 Motherboard.
5. If the signal is bad on P41-5, replace the A7 Reference.

### 704 Filter Test

1. Turn the signal generator on and remove the A6 Frac-N. Set the signal generator to the first frequency in column one in [Table 1-23](#). Use an extender board cable to connect a spectrum analyzer to J1. Tune the spectrum analyzer to the first frequency in column two of [Table 1-23](#) and check for power > -6 dBm. Tune the signal generator and spectrum analyzer to the next set of frequencies in the table and check for power. Continue until all frequencies have been checked. If all the signals are good continue to step d.

**Table 1-23**

Center Frequency (GHz)	J1 Frequency (GHz)
.300	4.771
.500	7.969
.750	5.971
1.25	4.976
2.0	7.969
3.0	5.971

2. If the signal is bad, check the signal out of the A29 20 GHz Doubler A6 Frac-N output port. If the signal out the A29 20 GHz Doubler is good, replace the cable.

3. If the signal out the A29 20 GHz Doubler is bad, replace the A29 20 GHz Doubler.
4. If the signal at J1 is good, turn power off and reinstall the A6 Frac-N.
5. Power the signal generator on and remove the A8 Output. Use an extender cable to connect a spectrum analyzer to J4. Tune the spectrum analyzer to the first frequency in column one of [Table 1-23 on page 1-32](#) and check for an approximate power of +10 dBm.
6. If an RF signal is present on J4, replace the A8 Output.
7. If an RF signal is not present on J4, replace the A6 Frac-N.

#### **705 F/2 Test**

1. Check 10 MHz Synthesis line on P33-15 using an oscilloscope. The signal period should be 100 ns with an amplitude of approximately 3 V<sub>p-p</sub>.
2. If the signal is good, replace the A6 Frac-N.
3. If the signal is bad, turn the signal generator power off and remove the A6 Frac-N. Measure the P33-15 again.
4. If the signal is good, replace the A6 Frac-N, if the signal is still bad, measure P41-5 on the A7 Reference. If the signal is good, at P41-5, replace the A31 Motherboard.
5. If the signal is bad on P41-5, replace the A7 Reference.

#### **706 FM Path Test**

1. While monitoring P31-22 (FM\_On\_H), loop self-test 706. Using an oscilloscope, check for a TTL transition from 0 Vdc to +5 Vdc. If the signal is not present, refer to A5 Sampler troubleshooting.
2. If the signal in step (1) is present, check P31-11 (FM) and loop self-test 706. Using an oscilloscope, check for a 0 Vdc to 3.3 Vdc transition. If the signal is not present, refer to A11 Pulse/Analog Modulation Generator troubleshooting.
3. If the signals in step (2) are present, replace the A6 Frac-N.

### Self-Tests 9xx: A10 ALC Self-Test Errors

Figure 1-7

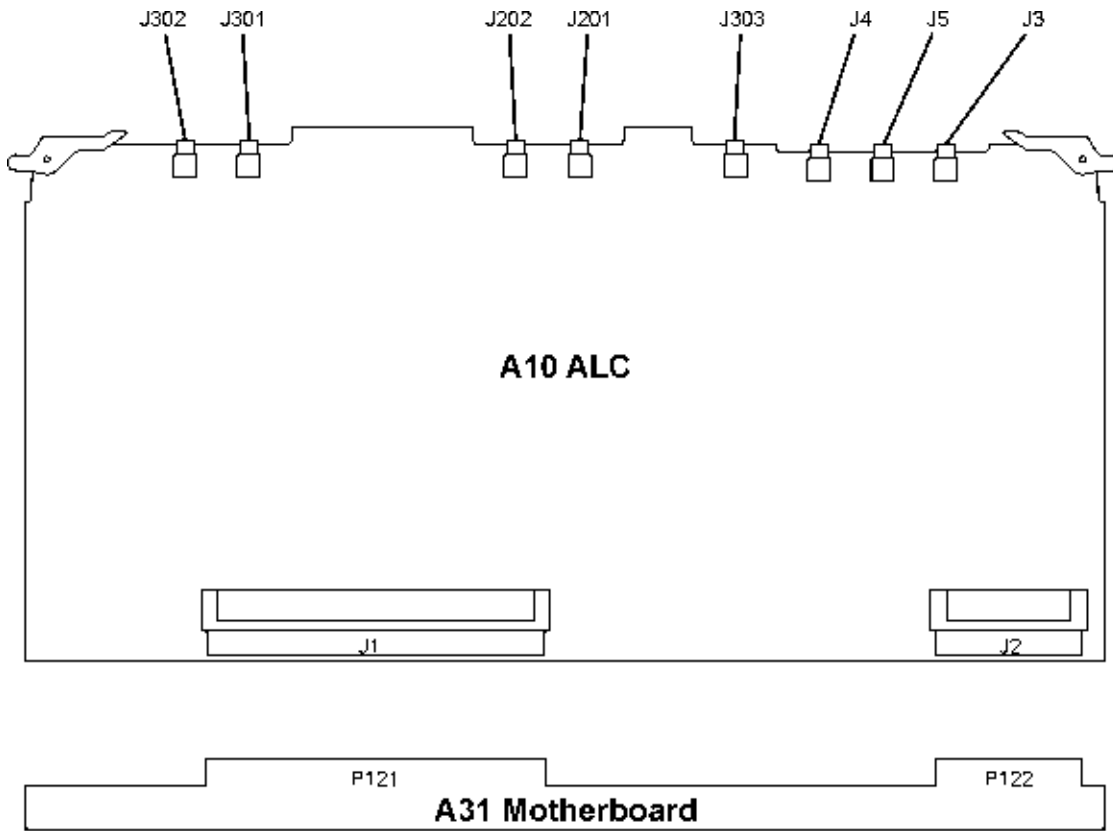

se953a

Before proceeding to the reported self-test error code, check the voltages in [Table 1-24](#). If any voltages are out of specification troubleshoot the supply problem first.

Table 1-24

Supply Voltage (Vdc)	Connector Pins	Minimum Value (Vdc)	Maximum Value (Vdc)	Origin
+32	P122-4	+31.04	+32.96	Main Supply
+15	P122-28	+14.55	+15.45	Main Supply
-15	P122-3,	-14.55	-15.45	Main Supply
+5.2	P122-2, 27	+5.04	+5.37	Main Supply
-5.2	P122-1, 26	+5.04	+5.37	Main Supply
+5.2 Digital high	P121-64, 65, 129, 130	+5.04	+5.36	Main Supply
+3.4 Digital Low	P121-60, 61, 62, 63, 125, 126, 127, 128	+3.29	+3.5	Main Supply

### **900 Power Supply**

1. Replace the 10 ALC.

### **901 Detector Test**

1. Turn the signal generator's RF power on and set the frequency to 10 GHz and the RF power level to +25 dBm. Disconnect the cable from J3 of the A10 ALC (W15) and connect the cable to a digital voltmeter. The digital voltmeter should measure -0.6 Vdc. If the signal is not present, refer to highband RF loop troubleshooting.
2. Turn the signal generator's RF power on and set the frequency to 1 GHz and the RF power level to +20 dBm. Disconnect the cable from J5 of the A10 ALC (W14) and connect the cable to a digital voltmeter. The digital voltmeter should measure -5.0 Vdc. If the signal is not present, refer to lowband RF loop troubleshooting.
3. If the above signals are present, replace the A10 ALC.

### **902 Detector Level to ALC Ref**

1. Turn the signal generator's RF power on and set the frequency to 1 GHz and the RF power level to +20 dBm. Disconnect the cable from J5 of the A10 ALC (W14) and connect the cable to a digital voltmeter. The digital voltmeter should measure -5.0 Vdc. If the signal is not present, refer to lowband RF loop troubleshooting.
2. Turn the signal generator's RF power on and set the frequency to 10 GHz and the RF power level to +20 dBm. Disconnect the cable from J3 of the A10 ALC (W15) and connect the cable to a digital voltmeter. The digital voltmeter should measure -0.6 Vdc. If the signal is not present, refer to highband RF loop troubleshooting.
3. If the above signals are present, replace the A10 ALC.

### **903 Level Test**

1. Turn the signal generator's RF power on and set the frequency to 10 GHz and the RF power level to +20 dBm. Disconnect the cable from J3 of the A10 ALC (W15) and connect the cable to a digital voltmeter. the digital voltmeter should measure -0.6 Vdc. If the signal is not present, refer to highband RF loop troubleshooting.
2. If the above signal is present, replace the A10 ALC.

## Self-Tests 10xx: A7 Reference (Option UNJ) Self-Test Errors

Figure 1-8

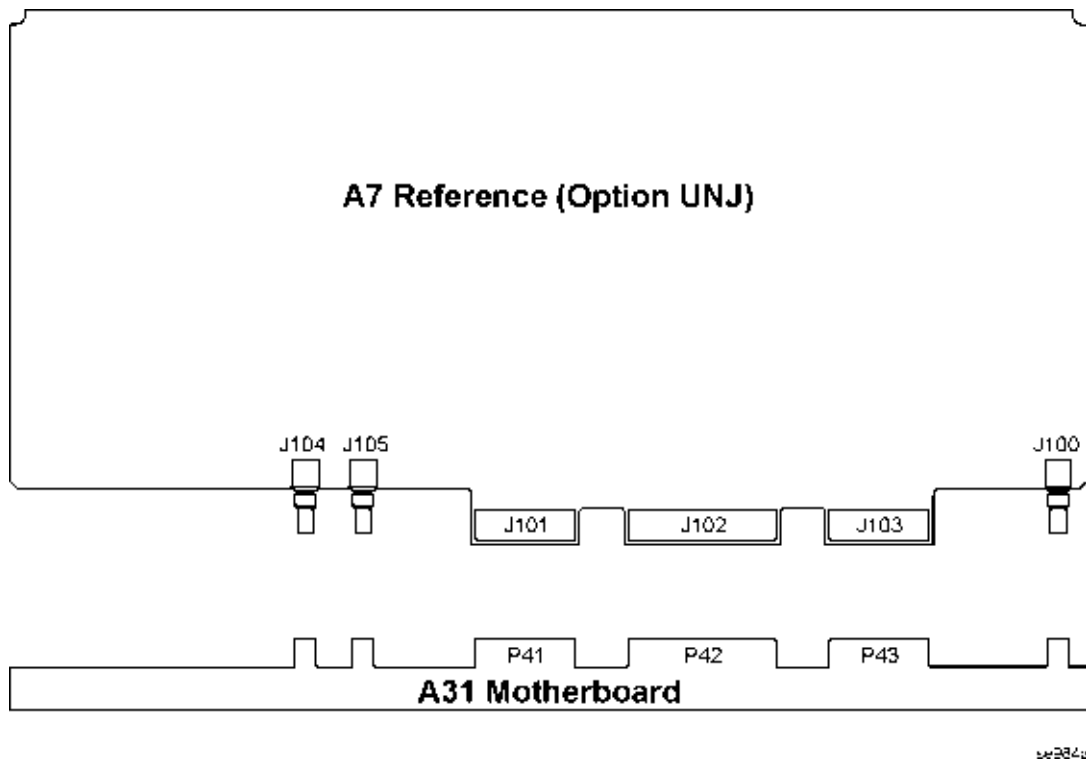

Before proceeding to the reported self-test error code, check the voltages in [Table 1-25](#). If any voltages are out of specification troubleshoot the supply problem first.

Table 1-25

Supply Voltage (Vdc)	Connector Pins	Minimum Value (Vdc)	Maximum Value (Vdc)	Origin
+15	P42-6, 21	+14.55	+15.45	Main Supply
-15	P42-2, 17	-14.55	-15.45	Main Supply
+9	P42-5, 20	+8.82	+9.18	YIG Driver

### 1000 Power Supply

1. Replace the A7 Reference.



**1001 10 MHz Test**

1. Using an oscilloscope, check P41-2 for a 10 MHz signal greater than 1.12 V<sub>p-p</sub>. If the signal is present, replace the A7 Reference.
2. If the signal is not present, replace the internal 10 MHz standard.

**1002 1 GHz Test**

1. Replace the A7 Reference.

## Self-Tests 11xx: A18 CPU Self-Test Errors

Figure 1-9

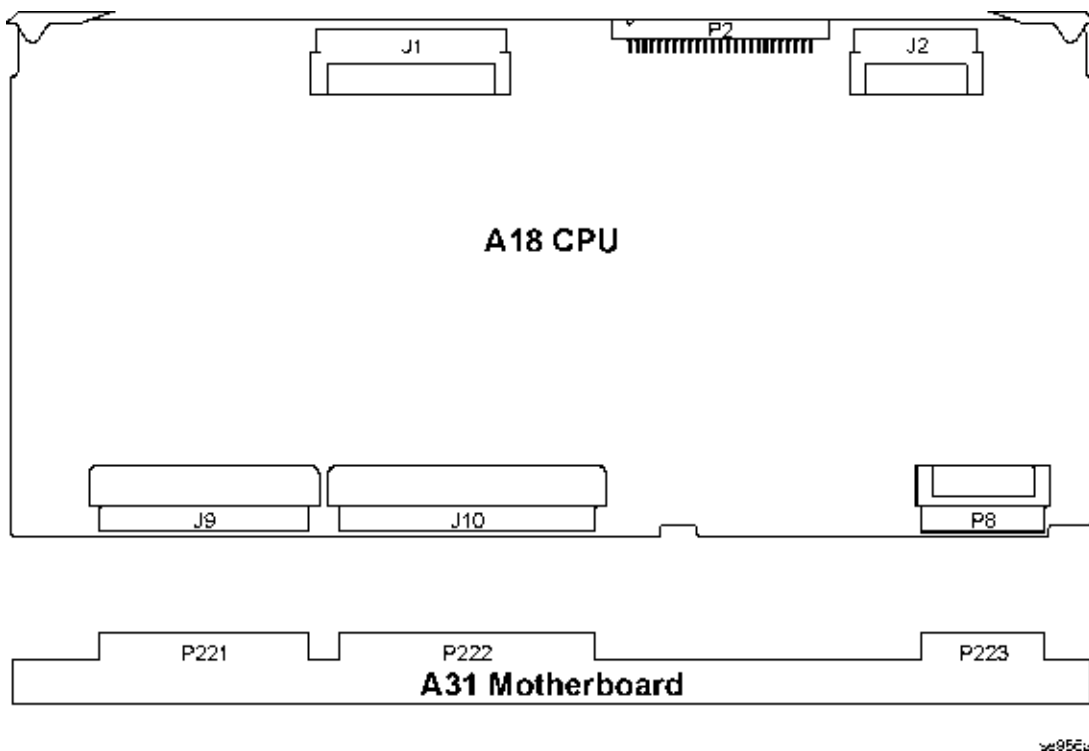

### 1100 Power Supply

The A18 CPU self-test verifies the presence of the supplies listed. These supplies are not checked during the turn-on check and are not necessary for the turn-on check to pass.

1. After running self-test, View Details and see which supply failed.
2. If the 10 VRef has failed, replace the A18 CPU. The 10 VRef is generated on the A18 CPU and used for the ADC circuit.
3. For a self-test failure other than the 10 VRef, measure the appropriate connector pin listed in the following table.

Table 1-26

Connector P223	Supply Voltage	Voltage Range
Pin 1	-5.2 Vdc	-5.2 .1 Vdc
Pin 17	-6 Vdc	-6 .1 Vdc
Pin 18	+9 Vdc	+9 .1 Vdc

4. If the voltages are present on the A31 Motherboard, turn power off, remove the A18 CPU and inspect the connector. If the pins look good, replace the A18 CPU.

5. If a supply voltage is not present on the connector, measure the appropriate point.

**Table 1-27**

<b>Connector P112</b>	<b>Supply Voltage</b>	<b>Voltage Range</b>
Pin 1, 2, 26, 27	-5.2 Vdc	-5.2 .1 Vdc
Pin 19, 44	-6 Vdc	-6 .1 Vdc
Pin 17, 18, 42	+9 Vdc	+9 .1 Vdc

6. If the voltage is present on P112 but not present on P223, replace the A31 Motherboard.

7. If the voltages are not present on P112, troubleshoot the A9 YIG Driver.

## Self-Tests 12xx: A26 MID Self-Test Errors

Figure 1-10

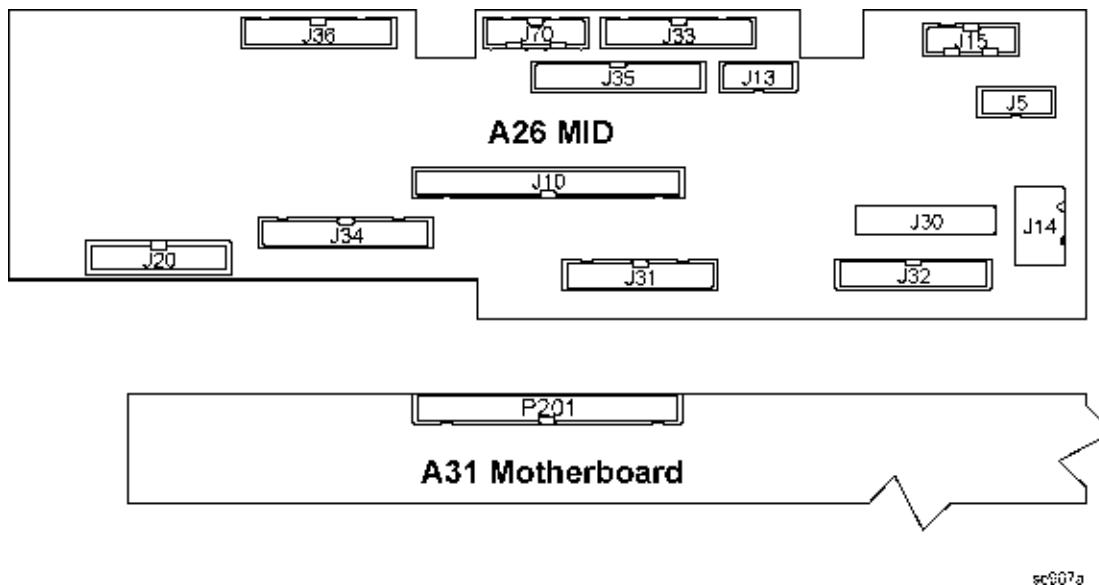

Before proceeding to the reported self-test error code, check the voltages in [Table 1-28](#). If any of these voltages are out of specification troubleshoot the supply problem first.

Table 1-28

Supply Voltage (Vdc)	Connector Pins	Minimum Value (Vdc)	Maximum Value (Vdc)	Origin
+32	P201-1	+31.04	+32.96	Main Supply
+15	P201-2, 3, 4	+14.55	+15.45	Main Supply
-15	P201-11, 12	-14.55	-15.45	Main Supply
+5.2	P201-13, 14, 15, 16, 17, 18	+5.04	+5.37	Main Supply
+10	P201-5, 6, 7, 8, 9, 10	+10	+10.4	Main Supply
-5.2	P201-31, 32	-5.1	-5.3	YIG Driver
+5.2 Digital high	P201-23	+5.04	+5.36	Main Supply
+3.4 Digital Low	P201-24	+3.29	+3.5	Main Supply
+8	P201-29	+7.5	+8.5	MID

### 1200 Power Supply

1. Press View Details, then use the arrow keys or RPG to highlight Self Test 1200. Press View Details. The results of the self-test should be displayed. Determine which supply or supplies have failed.
2. The table shows which microcircuits use the different supplies. Disconnect one microcircuit at a time and

run self-test 1200. If the test passes after disconnecting one or more microcircuits, replace the microcircuit. If self-test still fails after disconnecting all the microcircuits, replace the A26 MID. The table below shows the power supply each microcircuit.

**Table 1-29**

Microcircuit	A26 MID connector	+12 Vdc	+8 Vdc
A30 Modulation Filter	J31	✓	✓
A29 20 GHz Doubler	J32	✓	✓
A27 40 GHz Doubler	J33		✓

**1201 Mod Filter**

1. Disconnect the cable coming from the A23 Low Band Coupler/Detector to the A30 Modulation Filter. Connect a spectrum analyzer to the cable. Tune the source across the low band frequencies (250 kHz to 3.2 GHz) and record the lowest power level.
2. Disconnect the cable coming from the A29 20 GHz Doubler and connect a spectrum analyzer to the cable. Tune the source across the A29 20 GHz Doubler band of frequencies (3.2 GHz to 20 GHz) noting the lowest power level.
3. Compare the levels recorded to the levels shown on the RF Path Block.
4. If all power levels are good, replace the A30 Modulation Filter.
5. If the power level in either path is bad, troubleshoot that path.
6. If the power levels in both paths are bad, check the signal levels out of the A28 YIG Oscillator.

**1202 A29 20 GHz Doubler**

1. Disconnect the cable coming from the A28 YIG Oscillator to the A29 20 GHz Doubler and connect a spectrum analyzer to the cable. Tune the source frequency across the A28 YIG Oscillator range (3.2 GHz to 10 GHz) noting the lowest power level.
2. Compare the levels recorded to the levels shown on the RF Path Block.
3. If the power level is good, replace the A29 20 GHz Doubler.
4. If the power level is bad, replace the A28 YIG Oscillator.

**1203 40 GHz Doubler**

1. Disconnect the 0 to 20 GHz cable coming from the A30 Modulation Filter to the A27 40 GHz Doubler and connect a spectrum analyzer to the cable. Tune the source from 250 kHz to 20 GHz and record the lowest power level.
2. Disconnect the 10 to 20 GHz cable coming from the A30 Modulation Filter and connect a spectrum analyzer to the cable. Tune the source from 20 GHz to 40 GHz noting the lowest power level.
3. Compare the levels recorded to the levels shown on the RF Path Block.
4. If all power levels are good, replace the A27 40 GHz Doubler.
5. If the power level either or both paths is bad, troubleshoot the path.

### 1204 RF Path

This test checks for a dc voltage on the A10 ALC from the A23 Low Band Coupler/Detector and A24 High Band Coupler and A25 High Band Detector.

1. Connect a spectrum analyzer to the RF output of the signal generator. Turn the RF power on and verify the presence of an RF signal on the output. If no RF signal is present, troubleshoot the RF problem using the RF Path procedure.
2. If an RF signal is present on the RF output, set the signal generator to 4 GHz and 0 dBm. Measure the dc voltage on the cable going to J3 of the A10 ALC. The signal should be  $> -600$  mV. If the signal at J3 is good, go to step e.
3. If no dc signal is present on the cable to J3, check the output at the high band detector. If the signal is good at the detector replace the cable.
4. If no signal is present at the output of the high band detector, replace the high band detector.
5. If the signal is good at J3, set the signal generator's frequency to  $<1$  GHz and power to 0 dBm. Measure the dc voltage on the cable going to J5 on the A10 ALC.
6. If dc voltage in step e is  $-5.25$  Vdc, replace the A10 ALC.
7. If dc voltage is present, check for dc voltage on the output of the low band detector. If a dc voltage is present, replace the cable.
8. If no dc voltage is present, replace the low band detector.

## Self-Tests 13xx: A11 Analog/Pulse Modulation Generator Self-Test Errors

Figure 1-11

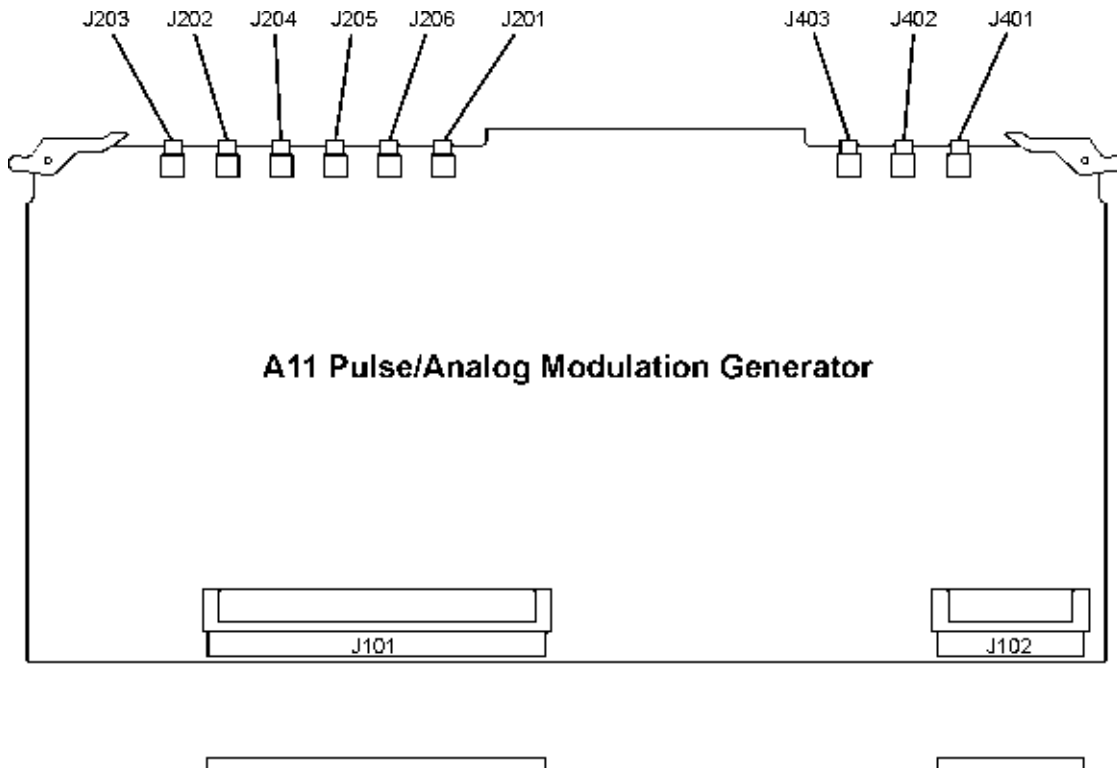

Before proceeding to the reported self-test error code, check the voltages in [Table 1-30](#). If any of these voltages are out of specification troubleshoot the supply problem first.

Table 1-30

Supply Voltage (Vdc)	Connector Pins	Minimum Value (Vdc)	Maximum Value (Vdc)	Origin
+15	P132-28	+14.55	+15.45	Main Supply
-15	P132-3	-14.55	-15.45	Main Supply
+5.2	P132-2, 27	+5.04	+5.37	Main Supply
-5.2	P132-1, 26	-5.1	-5.3	YIG Driver
+5.2 Digital high	P131-64, 65, 129, 130	+5.04	+5.36	Main Supply
+3.4 Digital Low	P131-60, 61, 62, 63, 125, 126, 127, 128	+3.29	+3.5	Main Supply

### 1300 Power Supply

1. Replace the A7 Reference.

### **1301 Internal Pulse Generator Clock**

1. Using an oscilloscope, measure P131-91 for a 10 MHz signal at 3.5 V<sub>p-p</sub>.
2. If the signal is good, replace the A11 Pulse/Analog Modulation Generator.
3. If the signal is bad, check P41-7. If the signal is good on P41-7, replace the A31 Motherboard
4. If the signal is bad on P41-7, replace the A7 Reference.

### **1302 Output**

1. Replace A11 Pulse/Analog Modulation Generator.

### **1303 Voltage Ref DAC**

1. Replace A11 Pulse/Analog Modulation Generator.

### **1304 20 GHz Pulse**

- a. Replace A11 Pulse/Analog Modulation Generator.

### **1305 40 GHz Pulse**

1. Replace A11 Pulse/Analog Modulation Generator.

### **1306 Standard 3 GHz Pulse**

1. Replace A11 Pulse/Analog Modulation Generator.

### **1307 Numeric Synthesizer**

1. Replace A11 Pulse/Analog Modulation Generator.

### **1308 Function Generator Channel 1**

1. Replace A11 Pulse/Analog Modulation Generator.

### **1309 Function Generator Channel 2**

1. Replace A11 Pulse/Analog Modulation Generator.

### **1310 Frequency Modulator**

1. Replace A11 Pulse/Analog Modulation Generator.

### **1311 Low Frequency Out**

1. Replace A11 Pulse/Analog Modulation Generator.

### **1312 Amplitude Modulation**

1. Replace A11 Pulse/Analog Modulation Generator.

### **1313 External 1**

1. Replace A11 Pulse/Analog Modulation Generator.



**1314 External 2**

1. Replace A11 Pulse/Analog Modulation Generator.

**1315 AM Path Loss**

1. Replace A11 Pulse/Analog Modulation Generator.

## Troubleshooting Unlocks

The phase lock loop refers to part of the frequency generating circuit used to maintain the phase relationship between the frequency generation loop and a reference frequency. By maintaining the phase relationship the frequency accuracy of the signal generator is guaranteed.

To maintain frequency accuracy the phase lock loop compares the phase of a signal from the reference assembly to the phase of the frequency loop signal. If the signals are slightly out of phase, the phase comparator circuit adjusts the frequency loop signal until the two signals are in phase. If the phase comparator circuit cannot adjust the phase of the frequency loop signal to agree with the reference signal, the phase comparator rails and generates an unlocked message. The unlock message is immediately displayed on the front panel display.

There are four phase lock circuits in the frequency generation loop that can generate error messages. These phase lock loops are located on the A6 Frac-N, A5 Sampler, and A7 Reference. There is also one other phase lock loop on the A11 Pulse/Analog Modulation Generator that can generate an error message when the signal generator is in phase modulation mode.

### 508 A6 Frac-N Loop Unlock

A 508 Frac-N unlock message indicates a failure of the A6 Frac-N.

1. Check P33-15 on the A31 Motherboard for the 10 MHz sync. approx.  $2 V_{p-p}$ .
2. If the signal is present replace the A6 Frac-N.
3. If the signal is not present, troubleshoot back to the A7 Reference.

### 513 1 GHz Out of Lock

A 513 1 GHz Out of Lock message indicates a failure on the A7 Reference.

1. Replace the A7 Reference.

### 514 Reference Oven Cold

The Reference Oven Cold Error message indicated the reference has not been connected to electrical power for 30 minutes. This message appears when the signal generator is unplugged or the reference assembly is removed. The message is controlled by a timer and should turn off after 30 minutes. This is not a failure unless the message does not go off after 30 minutes. If it continues to be displayed after 30 minutes, replace the A7 Reference.

### 515 10 MHz Signal Bad

A 515 10 MHz Signal Bad message indicates a problem on the A7 Reference.

A7 Reference (Standard)

1. Replace the A7 Reference.

A7 Reference (Option UNJ)

1. Check the 10 MHz signal into the A7 Reference from the 10 MHz standard.
2. The signal should be 10 MHz  $1.8 V_{p-p}$  into  $1 M\Omega$ .

3. If the 10 MHz signal is bad, replace the A32 10 MHz Crystal Oscillator.
4. If the signal is good, replace the A7 Reference.

### 520 Sampler Unlocked

A 520 Sampler unlock message indicates a failure of the A5 Sampler VCO loop.

1. Run self-test. If self-test fails, troubleshoot the problem reported.
2. Power-up the signal generator. Remove the A5 Sampler. Probe the mmx connection center pin on the right side of the A31 Motherboard in the A5 Sampler slot. There should be a 1 GHz signal >0 dBm.
3. If the 1 GHz signal is present, replace the A5 Sampler.
4. If the 1 GHz signal is not present, replace the A7 Reference.

---

**NOTE** Turn the signal generator off before re-installing any assembly.

---

### 521 YO Loop Unlocked

A 521 YO Loop unlocked message indicates a failure of the A5 Sampler's YO Phase detector circuit.

1. Set the signal generator to 5 GHz.
2. With the signal generator on, remove the A5 Sampler. Probe the mmx connectors on the A31 Motherboard

**Table 1-31**

Connector	Signal
right mmx connector	1 GHz >0 dBm from A7 Reference
center mmx connector	5 GHz from A29 20 GHz Doubler -6 dBm
left mmx connector	approx. 850 MHz >-6 dBm from A5 Sampler

3. If all signals are present replace the A5 Sampler.
4. If any signal is not present, troubleshoot to the signal generator and replace that assembly.

---

**NOTE** Turn the signal generator off before re-installing any assembly.

---

### 625 Internal Pulse Generator Unlock

A 625 internal pulse generator unlocked message indicates a failure on the A11 Pulse/Analog Modulation Generator.

1. Replace the A11 Pulse/Analog Modulation Generator.

## 626 Internal Mod Source Unlock

A 626 Internal Mod Source Unlock error message indicates a problem with the digital 10 MHz signal to the A11 Pulse/Analog Modulation Generator. This error message is turned on if the signal generator is in phase modulation mode and there is a problem with the 10 MHz digital signal to the in phase clock.

1. Set the signal generator to phase modulation mode.
2. Measure pin P131-91. The waveform is not a sine wave, but more like a distorted pulse waveform  $>2 V_{p-p}$ .
3. If the waveform is present, replace the A11 Pulse/Analog Modulation Generator.
4. If the signal is not present, replace the A7 Reference.

---

## Troubleshooting Unlevels

A leveled output power is obtained comparing a detected voltage with a reference voltage. The reference voltage is generated using DACs on the A10 ALC and the detected voltage is generated by coupling off a portion of the RF output signal and converting it to dc using detector diodes. When the reference and detected levels are the same the integrated output level remains constant. When the detected and reference levels are not the same, the integrator output ramps either up or down to increase or decrease the detected level. If the integrator can not get the detected voltage and the reference voltage to match, an unlevelled annunciator is displayed.

The Automatic Leveling Circuit (ALC) uses two detectors and two modulator diodes. The A23 Low Band Coupler/Detector is used for frequencies 2 GHz and below. The A25 Highband Coupler/Detector is used for all frequencies above 2 GHz. The modulator in the A23 Low Band Coupler/Detector is used to control the RF amplitude for frequencies 3.2 GHz and below. The modulator in the A30 Modulation Filter is used to control the amplitude for frequencies above 3.2 GHz.

The RF path must provide a minimum power level to the ALC loop for the ALC loop to work properly. The minimum power required is slightly higher than the maximum leveled power. The first step to troubleshooting a leveling problem is to verify the RF path power level.

### **Troubleshoot and correct any unlock problems before troubleshooting unlevelled problems.**

If the unlevelled annunciator is on:

1. Verify the signal generator's amplitude is not set higher than the maximum level specified on the data sheet. Verify that the signal generator's RF output is terminated into 50 ohms. If the unlevelled indication turns off after resetting the amplitude or terminating the RF output into 50 ohms, the signal generator is operating correctly. If the unlevelled indicator remains on, proceed to step 2.
2. Using a spectrum analyzer check the RF signal level at the RF output connector.

a. Signal generator and spectrum analyzer setup:

Signal Generator:

- Turn ALC Off
- Set Amplitude to 30 dBm
- Turn Modulation Off
- Turn RF On
- Set Sweep to Frequency
- Set Sweep Type to Step
- Set Start Frequency to 250 kHz
- Set Stop Frequency to 3.2 GHz
- Set Number of Points to 500

Spectrum Analyzer:

- Set Start Frequency to 225 kHz

- Set Stop Frequency to 3.25 GHz
  - Set Reference Level to +30 dBm
  - Set Display to Max Hold
- b. Connect the RF output of the signal generator to the spectrum analyzer. Measure and record the minimum power level.
  - c. Set the signal generator and spectrum analyzer start/stop frequencies to the next start/stop frequencies in [Table 1-32](#). Repeat step b above.

**Table 1-32**

Signal Generator		Spectrum Analyzer	
Start	Stop	Start	Stop
3.2 GHz	20 GHz	3.15 GHz	20 GHz
20 GHz	19.5 GHz	40 GHz	40 GHz

- d. If any of the frequency ranges do not produce power levels  $\geq$  the maximum leveled power shown in the [Table 1-33](#), set the signal generator to the frequency with the lowest power level and measure the power with a power meter. If the power level is low, troubleshoot the RF path before proceeding.

**Table 1-33**

20 GHz Models	Standard	Option 1EA	Option 1E1	Option 1E1 with 1EA
250 kHz to 3.2 GHz	+13 dBm	+16 dBm	+11 dBm	+15 dBm
3.2 GHz to 20 GHz	+13 dBm	+20 dBm	+11 dBm	+18 dBm
40 GHz Models				
250 kHz to 3.2 GHz	+9 dBm	+15 dBm	+7 dBm	+14 dBm
3.2 GHz to 20 GHz	+9 dBm	+18 dBm	+7 dBm	+16 dBm
20 GHz to 40 GHz	+9 dBm	+14 dBm	+7 dBm	+12 dBm

3. If the RF signal levels are good, most likely the problem is either a detector, ALC, or modulator. Before proceeding, turn ALC On and set the signal generator to maximum leveled power for the model and options you have and note the frequencies where the unlevelled condition occur. Later, when troubleshooting in ALC Off mode the unlevelled indication is turned off.

4. For each of the failed conditions listed, always start with the signal generator set to the following settings.
  - ALC Mode ALC Off
  - Amplitude +30 dBm
  - Attenuator Hold Mod On
  - RF On
  - Modulation Off

**Conditions:**

5. Unleveled only between 250 kHz and 2 GHz.  
If the unleveled problem only occurs between 250 kHz and 2 GHz, the problem is most likely the A23 Low Band Coupler/Detector.
  - a. Checking the A23 Low Band Coupler/Detector:
    - Set the signal generator to 1.9 GHz or a frequency where the signal generator is unleveled.
    - Connect a power meter or spectrum analyzer to the A23 Low Band Coupler/Detector output.
    - Set the signal generator to 1 GHz. Using the RPG adjust the amplitude level so the detected voltage on cable J5 of A10 ALC (W14) is -.117 Vdc. Using a power meter, measure the signal level at the end of the cable going to J3 of A30 Modulation Filter (W27). The power level should read 2.3 dBm .5 dB. If the voltage can not be adjusted to this level, troubleshoot the RF path.
    - If the problem is at some frequency other than 1 GHz, repeat the above step using the problem frequency. The dB p-p variation from 250 kHz to 2 GHz should be <2 dB.
    - If the dc level is bad, replace the A23 Low Band Coupler/Detector.
    - If the signal is good, replace the A10 ALC.
6. Unleveled only between 250 kHz and 3.2 GHz. If the unleveled problem only occurs between 250 kHz and 3.2 GHz, the problem is most likely the A8 Output or A10 ALC.
  - a. Checking Lowband Modulator Drive signal.
    - Set the signal generator to a frequency between 250 kHz and 3.2 GHz. Set the amplitude so the power meter reads +21 dBm on cable W27 going to J3 on A30 Modulation Filter.
    - Measure the voltage on the center pin on A31 Motherboard connector J1122. The voltage should be around +2.0 Vdc.
    - Reduce the amplitude setting to 0 dBm and the voltage on J1122 should move towards +.15 Vdc.
    - If the voltages are not correct or do not change as power is changed, replace the A10 ALC.
    - If the voltage changes, replace the A8 Output.
7. Unleveled only between 2 GHz and 20 GHz or 40 GHz. If the unleveled condition occurs only for frequencies >2 GHz to 20 GHz or 40 GHz, the problem is most likely the A25 Highband Coupler/Detector.
  - a. Checking the A25 Highband Coupler/Detector
    - Set the signal generator frequency to 19 GHz or a frequency where the signal generator is unleveled.
    - Connect a power meter or spectrum analyzer to the RF output connector.
    - Using the RPG adjust the power until the measured power level is +9 dBm. If the power can not be

adjusted to this level, troubleshoot the RF path.

- Remove the cable from J3 on the A10 ALC and measure the dc voltage on the center pin of the cable. The dc voltage should be  $-0.150 \text{ mVdc}$   $-0.05 \text{ Vdc}$
- Set the power level to 0 dBm and repeat the center pin measurement. The voltage should be  $-30 \text{ mVdc}$   $10 \text{ mVdc}$
- If the voltages are good, go to step 8.
- If the voltages are the same, replace the A25 Highband Coupler/Detector.

8. Unleveled only between 3.2 GHz and 20 GHz or 40 GHz.

If the unleveled condition occurs between 3.2 GHz and 20 GHz or 40 GHz, the problem is most likely the A30 Modulation Filter.

a. Checking the A30 Modulation Filter.

- Set the signal generator to 20 GHz or a frequency where the signal generator is unleveled and measured RF output level is +7 dBm. If the power can not be set to +7 dBm, troubleshoot the RF path.
- Remove the cable going to J4 on the A30 Modulation Filter and measure the voltage on the center pin. The voltage should be approximately +4.7 Vdc.
- Set the amplitude to -15 dBm. The voltage on the center pin should decrease a few mVdc.
- If the voltages are good, replace the A30 Modulation Filter.
- If the voltages are bad, go to step 7.

9. Unleveled only between 20 GHz and 40 GHz.

If the unleveled condition occurs between 20 GHz and 40 GHz, the problem is either with the A27 40 GHz Doubler or the A25 Highband Coupler/Detector.

a. Checking the A25 Highband Coupler/Detector

- Using a spectrum analyzer, check at the RF output signal level to the level shown in the Maximum Leveled Power table. The RF output level must be greater than the maximum specified power level.
- If the maximum power level is not greater than the maximum power level specified, troubleshoot the RF path starting with the signals out of the A30 Modulation Filter to the A27 40 GHz Doubler.
- If the signal is greater than the maximum specified power level, replace the A25 Highband Coupler/Detector.

10. Unleveled at all frequencies.

If the signal generator is unleveled at all frequencies, the problem is most likely the A10 ALC.

a. Checking the A10 ALC.

- Run a complete self-test and troubleshoot the reported failure.



## Troubleshooting Adjustment Problems

When an adjustment does not work or fails to resolve a problem and all self-tests have passed, use the following table to locate the most likely failure.

**Table 1-34 Troubleshooting Help for Failed Adjustments**

<b>Adjustment that is failing...</b>	<b>Assemblies most likely causing failure...</b>
ADC Calibration	A18 CPU
YIG-Driver Pre-Tune Calibration	A9 YIG Driver A28 YIG Oscillator A5 Sampler A6 Frac-N
VCO Bias Frac-N Calibration	A6 Frac-N
Internal Source Calibration	A11 Pulse/Analog Modulation Generator
AM Audio Path Offset Calibration	A11 Pulse/Analog Modulation Generator
KV vs. Frequency Calibration	A6 Frac-N
Timebase Calibration	A7 Reference
FM Scale Offset Calibration	A11 Pulse/Analog Modulation Generator
FM Path Offset Calibration	A11 Pulse/Analog Modulation Generator A6 Frac-N
FM In-band Offset Calibration	A6 Frac-N
FM Inverting Amplifier Offset Calibration	A6 Frac-N
FM 1/2 Path Ratio Gain Calibration	A11 Pulse/Analog Modulation Generator
Mod Source Relative Gain Calibration	A11 Pulse/Analog Modulation Generator
FM/PM Out-of- Band Calibration	A6 Frac-N
FM/PM YO Frequency Compensation Calibration	A9 YIG Driver A28 YIG Oscillator
DC FM Calibration	A6 Frac-N A11 Pulse/Analog Modulation Generator
Low Frequency Output Calibration	A11 Pulse/Analog Modulation Generator
External Input Peak Detector Calibration	A11 Pulse/Analog Modulation Generator
ALC Dynamic Calibration	A10 ALC A30 Modulation Filter A8 Output
Power Flatness Calibration	A10 ALC RF Path
Attenuator Calibration-Low Band and High Band Power	AT1 RF Path
Attenuator Calibration-High Band and High Power	AT1 RF Path
Attenuator Calibration-Low Band and Low Power	AT1 RF Path

**Table 1-34 Troubleshooting Help for Failed Adjustments**

<b>Adjustment that is failing...</b>	<b>Assemblies most likely causing failure...</b>
Attenuator Calibration-High Band and Low Power	AT1 RF Path
ALC Modulator Calibration	A30 Modulation Filter A8 Output
AM Gain Calibration	A11 Pulse Modulation Generator
Gain Adjustment Bypass Calibration (Frequencies $\leq$ 3.2 GHz)	A8 Output A6 Frac-N
Pulse Width Calibration	A11 Pulse/Analog Modulation Generator A30 Modulation Filter A8 Output

## Troubleshooting ADC Adjustment Failures

The ADC adjustment adjusts the ADC reference voltage to match the A18 CPU +10 Vdc reference. There are three reasons the adjustment could fail:

- problems with the +10 Vdc reference
- A18 CPU problems
- analog mux on another assembly is starting to fail

### **Procedure:**

1. Run self-test 1100. If self-test 1100 passes, the +10 Vdc reference is good; proceed to step 2.
2. To see if an analog mux is failing and loading the supply, turn power off and remove the A5 Sampler, A6 Frac-N, and A7 Reference.
3. Run the adjustment. If the adjustment passes, turn power off, reinstall one assembly at a time and run the adjustment until the problem assembly is located.
4. If self-test fails, turn power off, reinstall the assemblies and remove the A8 Output, A9 YIG Driver, and A10 ALC.
5. Run the adjustment. If the adjustment passes, turn power off, reinstall one assembly at a time and run the adjustment until the problem assembly is located.
6. If self-test fails, turn power off, reinstall the assemblies and remove the ribbon cable from J10 on the A26 MID (W35).
7. If self-test passes, replace the A26 MID.
8. If self-test fails, replace A18 CPU.

## Troubleshooting Performance Test Problems

When a performance test fails and all self-tests have passed, use the following table to locate the most likely failure.

**Table 1-35 Troubleshooting Performance Test Problems**

Performance test that is failing...	Action to perform...
Maximum Leveled Output Power	Refer to “ <a href="#">Troubleshooting the RF Path</a> ” on page 1-58.
Power Level Accuracy	Perform Power Flatness Calibration, Attenuator Calibration-Low Band and High Band Power, Attenuator Calibration-High Band and High Power, Attenuator Calibration-Low Band and Low Power, and Attenuator Calibration-High Band and Low Power.
Internal Pulse Modulation Level Accuracy Internal Pulse Modulation Rise/Fall Time Internal Pulse Modulation Minimum Pulse Width	If the frequency $\leq 3.2$ GHz, check the A11 Pulse/Analog Modulation Generator or the A8 Output.  If the frequency is $> 3.2$ GHz, check A11 Pulse/Analog Modulation Generator and the A10 ALC.  If the Internal Pulse Modulation Minimum Pulse Width test fails a Pulse Width Calibration should be performed prior to replacing any assembly.
DC FM Carrier Offset	Perform DC FM Calibration.  If still failing, check A11 Pulse/Analog Modulation Generator and A6 Frac-N.
External AM Frequency Response	If the frequency is $\leq 3.2$ GHz, check the A11 Pulse/Analog Modulation Generator or the A8 Output.  If the frequency is $> 3.2$ GHz, check the A11 Pulse/Analog Modulation Generator and the A10 ALC.
Internal FM Frequency Response	Perform FM adjustments.  If still failing check A11 Pulse/Analog Modulation Generator and A6 Frac-N.
External Phase Modulation Frequency Response	Perform FM adjustments.  If still failing check A11 Pulse/Analog Modulation Generator and A6 Frac-N.
Internal FM Distortion	Perform FM adjustments.  If still failing check A11 Pulse/Analog Modulation Generator and A6 Frac-N.
Internal Phase Modulation Distortion	Perform FM adjustments.  If still failing check A11 Pulse/Analog Modulation Generator and A6 Frac-N.
External FM Deviation Accuracy	Perform FM adjustments.  If still failing check A11 Pulse/Analog Modulation Generator and A6 Frac-N.

**Table 1-35 Troubleshooting Performance Test Problems**

<b>Performance test that is failing...</b>	<b>Action to perform...</b>
External Phase Modulation Deviation Accuracy	Perform FM adjustments.  If still failing check A11 Pulse/Analog Modulation Generator and A6 Frac-N.
External Pulse Modulation ON/OFF Ratio	If the frequency is $\leq 3.2$ GHz, check the A11 Pulse/Analog Modulation Generator or the A8 Output.  If the frequency is $> 3.2$ GHz, check the A11 Pulse/Analog Modulation Generator and the A10 ALC.
Harmonic Spurious	Refer to <a href="#">“Troubleshooting Harmonic Spurious”</a> on page 1-62.
Sub-Harmonic Spurious	Refer to <a href="#">“Troubleshooting Harmonic Spurious”</a> on page 1-62.
Non-Harmonic Spurious	Refer to <a href="#">“Troubleshooting Non-Harmonic Spurious”</a> on page 1-65.
Single-Sideband Phase Noise	Refer to <a href="#">“Troubleshooting the RF Path”</a> on page 1-58.

## Troubleshooting the RF Path

Troubleshooting RF Path procedure:

- preset the signal generator
- set a frequency
- open ALC loop (ALC Off)
- set signal generator to maximum power
- check power levels in the RF path (power levels are included on the RF block diagram)

### ALC and RF problems

1. Run a full self-test and troubleshoot any reported failures before proceeding.
2. From [Table 1-36](#) determine the frequencies where the problem occurs.

**Table 1-36**

<b>Frequencies</b>	<b>Assemblies</b>
All frequencies	A27 40 GHz Doubler (40 GHz models only) A28 YIG Oscillator A29 20 GHz Doubler A30 Modulation Filter AT1 (Option 1E1) RF Output Connector
250 kHz to 2 GHz	A6 Frac-N A8 Output A27 40 GHz Doubler A29 20 GHz Doubler A30 Modulation Filter A25 Highband Coupler/Detector AT1 (Option 1E1) RF Output Connector
250 kHz to 20 GHz	A23 Low Band Coupler/Detector A8 Output
3.2 GHz to 20 GHz/40 GHz	A27 40 GHz Doubler (40 GHz models only) A29 20 GHz Doubler A30 Modulation Filter AT1 (Option 1E1) RF Output Connector
20 GHz to 40 GHz	A25 Highband Coupler/Detector A27 40 GHz Doubler A30 Modulation Filter AT1 (Option 1E1) RF Output Connector

3. Perform the following steps:

- press Preset

- press Frequency - set signal generator to frequency in problem area
  - press Amplitude - set to +25 dBm
  - press RF ON/OFF - turn RF On
  - turn ALC Off
  - Power Search Manual
  - Do Power Search
4. Using the RF Path Block Diagram, check the power levels at the points shown.
  5. Once the problem is located, verify any cable between assemblies is good before replacing the assembly.
  6. To measure the A6 Frac-N output level, with the signal generator on, remove the A8 Output and probe the right hand mmx connector's center pin. The power level should be  $\geq +5$  dBm.

---

**WARNING** Always turn the signal generator off before installing any assembly.

---

7. If power levels look good through the path in ALC Off mode, the problem is most likely in the ALC loop. Go to troubleshooting the ALC loop.

### Troubleshooting Pulse Modulation

1. Run a full self-test and troubleshoot any reported failures before proceeding.
2. Determine the frequency of the pulse modulation problem.
3. Configure the signal generator to the pulse modulation setting that produces the problem.
4. Connect an oscilloscope to the LF OUTPUT connector. The waveform should be present on the oscilloscope.
5. If the waveform is present, continue to step 7.
6. If the waveform is not present or the signal is not the correct amplitude or type, replace the A11 Pulse/Analog Modulation Generator.
7. Turn ALC Off. If in ALC On mode, the ALC bandwidth causes a reduction in pulse amplitude at pulse widths  $< 1\mu\text{s}$ . If turning ALC Off corrects the problem, then verify the user has set up pulse modulating in either ALC Off or Power Search Modes.

### Troubleshooting Problems <3.2 GHz

8. If the pulse modulation problem occurs at <3.2 GHz, check P52-23 on the A31 Motherboard. Compare the results with [Table 1-37](#).

**Table 1-37**

Pulse On	Pulse Off
+5 Vdc	0 to +5 Vdc (pulses at modulation rate)

9. If signal levels are good, replace the A8 Output.
10. If the signals are bad, replace the A11 Pulse/Analog Modulation Generator.

**Troubleshooting Problems >3.2 GHz**

11. If the pulse modulation problem occurs >3.2 GHz, remove the cable A30 Modulation Filter J7 (W17). Probe the end of the cable. Compare the results with [Table1-38](#).

**Table 1-38**

<b>Pulse On</b>	<b>Pulse Off</b>
+5 Vdc	0 to +5 Vdc (pulses at modulation rate)

12. If the signal levels are good, replace the A30 Modulation Filter.

13. if the signal levels are bad, replace the A11 Pulse/Analog Modulation Generator.



### Troubleshooting AT1 Attenuator

Starting from +25 dBm, the attenuator steps when the power is changed from between +5.1 dBm and +5.0 dBm. Continuing to lower the power level, the next switch occurs between -4.99 dBm and -5.0 dBm. The next change is between -14.99 dBm and -15.0 dBm and so on. The last change occurs between -104.99 dBm and -105.0 dBm.

1. If the attenuator switches at the switch points but the power does not change or the power changes more or less than expected, replace the attenuator.
2. If the attenuator does not switch, press: Utility > more 1 of 2 > Instrument Info > Options Info  
An Option 1E1 should be listed.
3. If Option 1E1 is not listed, the option is either not installed or the configuration file is bad. The signal generator will need to be returned to Agilent for service.
4. If Option 1E1 is listed, turn the signal generator off and remove W36 from J13 on the A26 MID.
5. Turn the signal generator on and probe the following pins on J13.
  - Pin 1 +15 Vdc  $\pm$ .75 Vdc
  - Pin 2 +5.2 Vdc .5 Vdc

Table 1-39 shows the amplitude ranges and the corresponding attenuator switch control line voltages. Attenuation is switched in at +3 Vdc .75 Vdc and switched out at 0 Vdc.

**Table 1-39**

Amplitude Levels	Pin Numbers and Voltages				
	J13-5 40B dB Atten. Step	J13-6 20 dB Atten. Step	J13-7 40C dB Atten. Step	J13-9 10 dB Atten. Step	J13-10 5 dB Atten. Step
+25 to +5.1 dBm	0	0	0	0	0
+5.0 to -4.99 dBm	0	0	0	0	+3
-5.0 to -14.99 dBm	0	0	0	+3	+3
-15.0 to -24.99 dBm	0	+3	0	0	+3
-25.0 to -34.99 dBm	0	+3	0	+3	+3
-35.0 to -44.99 dBm	+3	0	0	0	+3
-45.0 to -54.99 dBm	+3	0	0	+3	+3
-55.0 to -64.99 dBm	+3	+3	0	0	+3
-65.0 to -74.99 dBm	+3	+3	0	+3	+3
-75.0 to -84.99 dBm	+3	0	+3	0	+3
-85.0 to -94.99 dBm	+3	0	+3	+3	+3
-95.0 to -104.99 dBm	+3	+3	+3	0	+3
>-105.0 dBm	+3	+3	+3	+3	+3

6. If the voltages are correct, replace the attenuator.
7. If the voltages are not correct, replace the A26 MID.

---

## Troubleshooting Harmonic Spurious

Harmonics are multiples of the output frequency. The second harmonic is two times the output frequency at an x dBc down. If the harmonic falls beyond the frequency range of the signal generator, the harmonic is not specified or measured.

To measure harmonics that fall within the signal generator frequency range, set the signal generator and spectrum analyzer to the harmonic frequency and set the signal generator to a specified power level. Measure the output signals peak power level on the spectrum analyzer. This peak power level is the reference level for the harmonic measurement. Turn on Marker Delta, set the signal generator to the fundamental frequency, and measure the power level of the fundamental frequency. The dBc value is the difference between the fundamental peak power level and the harmonic frequency power level.

### 20 GHz Models

Harmonic problems with a fundamental frequency between 500 kHz and 3.2 GHz.

1. Set the signal generator as follows:
  - Frequency - set to harmonic frequency to be measured
  - Amplitude +10 dBm
  - ALC Off
  - Amplitude Power Search (softkey)
2. Remove the cable on A30 Modulation Filter J3 (W27). Connect the spectrum analyzer to the cable.
3. Set the spectrum analyzer to the harmonic frequency, then press peak search and marker delta.
4. Set the signal generator to the fundamental frequency of the harmonic.
5. Using the delta marker, read the harmonic power level on the spectrum analyzer. Compare the spectrum analyzer reading to the specifications in [Table 1-40](#).

**Table 1-40**

<b>Harmonic Specifications</b>	
<-30 dBc	1 MHz to 2 GHz
-55 dBc	2 GHz to 3.2 GHz

6. If the harmonics do not meet specifications, replace the A8 Output.
7. If harmonic meet specifications reconnect the cable to the A30 Modulation Filter J3 and remove the cable going to A30 Modulation Filter J2 (W31). Connect the spectrum analyzer to the A30 Modulation Filter J2.
8. Set the signal generator and spectrum analyzer to the harmonic frequency, then on the spectrum analyzer, press marker peak search and then delta marker.
9. Set the signal generator to the fundamental frequency of the harmonic.
10. Using the delta marker, read the harmonic power level on the spectrum analyzer. Harmonic level should be  $\leq -55$  dBc.
11. If the harmonic level is  $> -55$  dBc, replace the A30 Modulation Filter.

## 20 GHz Models

Harmonic problems with a fundamental frequency between 3.2 GHz and 20 GHz

1. Set the signal generator as follows:
  - Frequency - set to harmonic frequency to be measured
  - Amplitude +10 dBm
  - ALC Off
  - Amplitude Power Search (softkey)
2. Remove the cable from the A29 20 GHz Doubler J2. Connect the spectrum analyzer to A29 20 GHz Doubler J2.
3. Set the spectrum analyzer to the harmonic frequency, press marker peak search and then delta marker.
4. Set the signal generator to the fundamental frequency of the harmonic.
5. Using the delta marker, read the harmonic power level on the spectrum analyzer.

**Table 1-41**

<b>Harmonic Specifications</b>	
2nd harmonic	≤-15 dBc
3rd harmonic	≤-10 dBc

6. If harmonics do not meet specification, replace the A29 20 GHz Doubler.
7. If harmonics meet or exceed specification, reconnect the cable to the A29 20 GHz Doubler J2 and remove the cable going to the A30 Modulation Filter J2 (W31). Connect the spectrum analyzer to the A30 Modulation Filter J2.
8. Set the signal generator and spectrum analyzer to the harmonic frequency. On the spectrum analyzer, press marker peak search and delta marker.
9. Set the signal generator to the fundamental frequency of the harmonic.
10. Using the delta marker, read the harmonic power level on the spectrum analyzer. Harmonics should be ≤-55 dBc.
11. If the harmonics do not meet specification, replace the A30 Modulation Filter.

## 40 GHz Models Only

Harmonic problems with a fundamental frequency between 2 GHz and 20 GHz

1. Set the signal generator as follows:
  - Frequency - set to harmonic frequency to be measured
  - Amplitude +10 dBm
  - ALC Off
  - Amplitude Power Search (softkey)
2. Remove the cable from the A30 Modulation Filter J2 (W31). Connect the spectrum analyzer to A30 Modulation Filter J2.

3. Set the spectrum analyzer to the harmonic frequency and press marker peak search and delta marker.
4. Set the signal generator frequency to the fundamental frequency of the harmonic.
5. Using the delta marker, read the harmonic power level on the spectrum analyzer. The harmonic level should be  $\leq -55$  dBc.
6. If the harmonics do not meet specification, replace the A30 Modulation Filter.
7. If the harmonics meet or exceed specification, reconnect the cable to the A30 Modulation Filter J2 and remove the cable going to A27 40 GHz Doubler output (W30). Connect the spectrum analyzer to the A27 40 GHz Doubler J2.
8. Set the signal generator and spectrum analyzer to the harmonic frequency. Press marker peak search and delta marker.
9. Set the signal generator to the fundamental frequency of the harmonic.
10. Using delta marker, read the harmonic power level on the spectrum analyzer. The harmonics should be  $< -45$  dBc the signal generator's specification.
11. If the harmonics do not meet specification, replace the A27 40 GHz Doubler.

## Troubleshooting Non-Harmonic Spurious

There are nine different groupings a spur can fall into. The grouping determines what assembly is most likely generating the spur. The procedure for troubleshooting spurs is to identify the grouping based on failing a performance test, checking for loose or broken cables or castings, and replacing the assembly.

**Table 1-42**

Mixing Spurs	These spurs are generated by the mixing products of the RF and IF signals on the A8 Output. The instrument is tuned to a frequency in the Heterodyne-Band (250 kHz to 250 MHz) to measure these spurs.
Power Supply Spurs	These spurs are generated by the power supply switching at a 100 kHz rate. If the test fails for these spurs, change A19 Power Supply.
Offset Reference Spurs	These spurs are generated by the 10 MHz frequency reference on the A7 Reference.
Clock Spurs	Two clocks on the A11 Pulse/Analog Modulation Generator generate these spurs. The first clock is 33.554432 MHz and is used by the numeric synthesizer. The second clock is 100 MHz and is used by the internal pulse generator.
RF and LO Feedthrough Spurs	When the instrument is tuned to a Heterodyne Band (250 kHz to 250 MHz) frequency, the RF and LO feeds through from the mixer on the A8 Output generates spurs on the RF output.
Frac-N Feedthrough	These spurs are generated by the Frac-N frequency coupling onto the low-band signal as it leaves the A6 Frac-N. The spurs then appear at the Frac-N frequency at the RF output.
Sampler Spurs	These spurs are generated on the A5 Sampler by the sampler LO and IF frequencies.
Frac-N 250 MHz Crossing Spurs	These spurs are generated by either the A5 Sampler, A6 Frac-N, or A7 Reference. They occur when a harmonic of the Frac-N frequency equals a harmonic of 250 MHz. The spurs are measured in highband at 133 kHz offset from the CW frequency.
IF 250 MHz Crossing Spurs	These spurs are generated on the A5 Sampler. They are caused by harmonics of the A5 Sampler IF. The spurs are measured in highband at 133 kHz offset from the CW frequency.

## Troubleshooting Option UNJ Phase Noise

Poor grounds or shielding problems in either the test environment or the measurement system can cause the phase noise measurement to fail. Physical vibration is another common cause of phase noise. Before performing a phase noise measurement make sure all covers are installed, the work surface is free of physical vibrations, and the phase noise system is working properly.

Phase noise failures at specific offsets are fairly predictable. After making sure the measurement accurately reflects a failure, use [Table 1-43](#) to troubleshoot phase noise problems. The troubleshooting procedure consists of assembly substitution.

**Table 1-43**

Frequency Offset	Most Likely Assembly
0 to 100 Hz	A32 High Stability Time Base
100 Hz to 10 kHz	A7 Reference
10 kHz to 100 kHz	A5 Sampler
>100 kHz to 1 MHz	A28 YIG Oscillator or A9 YIG Driver
Frequencies <3.2 GHz	A8 Output
Frequencies >3.2 GHz	A29 20 GHz Doubler or A30 Modulation Filter
Frequencies >20 GHz	A27 40 GHz Doubler

**NOTE** In non-Option UNJ signal generators, the most likely assemblies and frequency offset are the same except for <100 Hz. In non-Option UNJ signal generators the most likely assembly for <100 Hz offset is the A7 Reference.

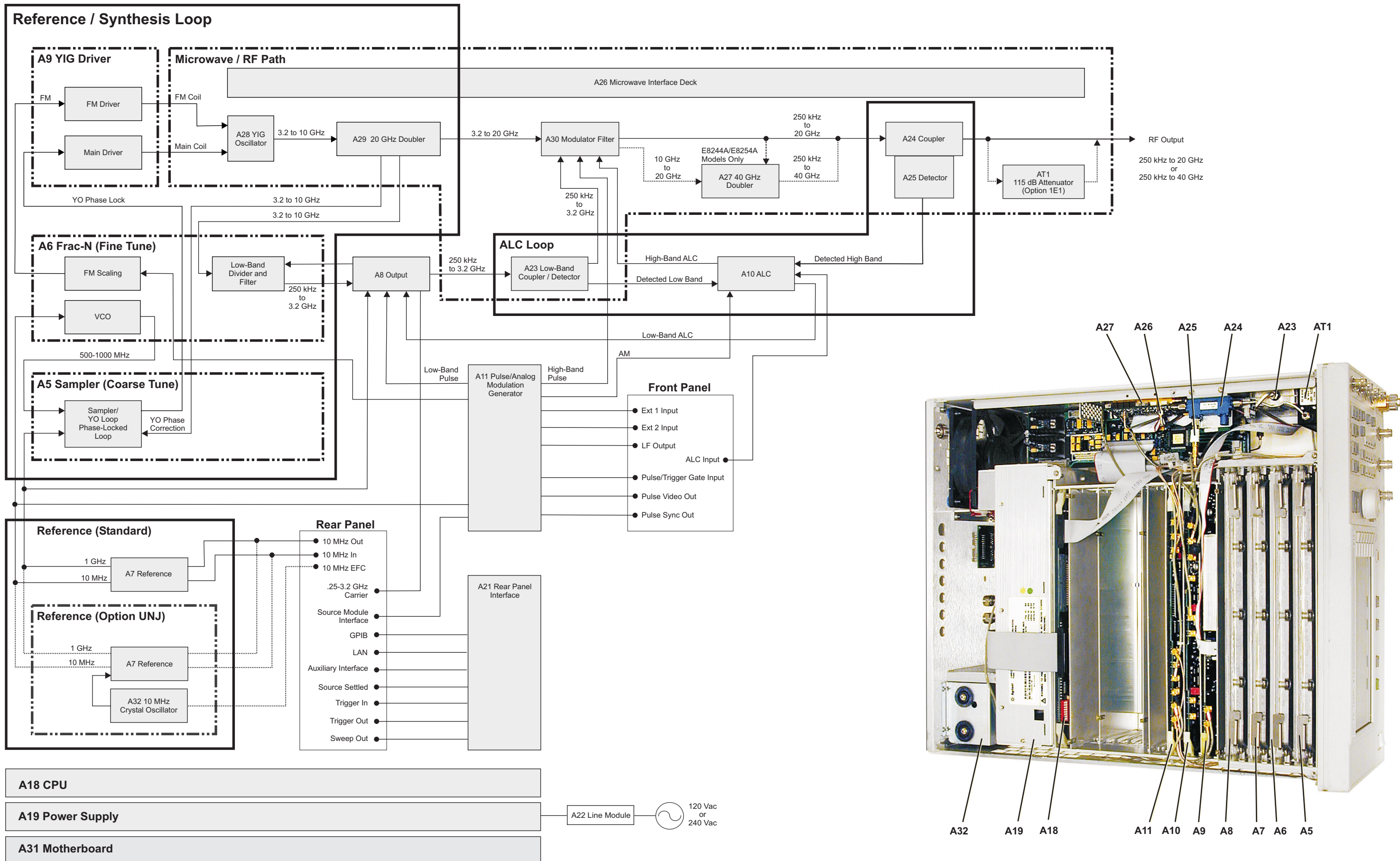





## Overall Block Description

The objective of the overall block description is to provide a functional overview of the Performance Signal Generator (PSG). Some of the functional blocks discussed are common to many types of instruments while others are more specific to signal generators.

### Common functions:

- Power Supply
- A18 CPU
- Input/Output Interface

### Specific signal generator functions:

- Frequency Generation
- Output Power Level Control
- Modulation

## A19 Power Supply

### Voltages

The main power supply converts line voltage (120 Vac or 240 Vac) to regulated dc voltages. Some of the required dc voltages are not directly provided by the main power supply and are generated by converting the main power supply voltages. Converting is done on different assemblies and the adjusted voltages are routed to the required assemblies.

### Line Module

The line voltage is connected to the power supply through the A22 Line Module. The power supply automatically detects and adjusts to different line voltages. Line voltage selection is not required. The power supply has an internal line fuse. If the fuse opens, the power supply must be replaced.

### Power supply thermal sensors

Two thermal sensors are used to prevent over heating of the signal generator. One sensor is internal to the A19 Power Supply and the other is on the A8 Output. The amber and green LEDs on the front panel will blink on and off when the signal generator goes into thermal shutdown.

## A18 CPU

The A18 CPU controls all activities in the signal generator. The A18 CPU translates information entered from the front panel keys, LAN, GPIB, or Auxiliary Interface (RS-232) into machine level instructions and communicates the instructions on the internal buses. The A18 CPU also monitors critical circuits for unlevelled and unlocked conditions and reports problems on the display.

## Input/Output Interface

Located on the front panel are the A1 Keyboard, A2 Display, and A3 Power Switch. Input to the signal generator is done through the front panel keypad and the display softkeys. Output from the signal generator is done through the front panel display and the RF output connector. Above the power switch is an amber and

green Light Emitting Diodes (LED). When lit the amber LED indicates that line voltage is present and the signal generator is in standby mode. When lit the green LED indicates the signal generator is in the power-on mode.

#### Front panel hardkeys/softkeys

Some front panel keys are labeled Hardkeys and are dedicated to specific functions. Dedicated hardkeys are used to select the most commonly used features, entered values, and control the display's contrast and intensity. Keys along the display are labeled Softkeys and are used to select the function shown to the left of the softkey on the display. As softkeys are pressed the softkey functions change. The front panel keypad uses a row and column configuration. Pressing a key makes a connection between a row and column. The row and column information is routed to the A18 CPU where it is interpreted and the appropriate action is taken.

#### A2 Display

An LCD provides information about the instrument's settings and condition. The LCD requires a power supply, lighting, and data. The light bulb for the back-light is powered by the A4 Inverter that converts a dc voltage to the required ac voltage. Data is generated on the A18 CPU and routed to the LCD through the A3 Power Switch.

#### Rear Panel

The power line module, LAN, GPIB, RS-232, and A20 SMI connections are located on the rear panel.

#### RF output connectors

The RF output connector is an APC 3.5 male or Type-N (Option 1ED) on the E8241A and E8251A models and a 2.4 mm male on the E8244A and E8254A models. The signal generator's model and options determine what additional connectors are installed and if the connectors are located on the front or rear panels.

## Frequency Generation

The YIG oscillator generates frequencies from 3.2 GHz to 10 GHz. For desired frequencies above 3.2 GHz, the output of the YIG oscillator is multiplied by two (10-20 GHz), or multiplied by four (20-40 GHz). These frequencies follow the high frequency path. For frequencies up to 3.2 GHz, the YIG oscillator is tuned in the 4-8 GHz range and the output is divided by 2/4/8/16. If the desired frequency is below 250 MHz, an additional mixer is used. These frequencies follow the low frequency path.

### Highband Path - Frequencies 3.2 GHz and Above

The output of the YIG oscillator is routed to the A29 20 GHz Doubler microcircuit. Depending on the desired frequency, the signal is routed through a frequency doubler circuitry or bypasses the doubler circuitry. The signal is then amplified and filtered. The output of this microcircuit is routed to the A30 Modulation Filter, which contains modulator, additional amplifiers, and filtering. If the signal generator is a 20 GHz model, the output of the A30 Modulation Filter is routed to the A24 High Band Coupler and A25 High Band Detector, through the optional AT1 attenuator and to the front panel RF output connector. If the signal generator is a 40 GHz model, the A30 Modulation Filter routes the signal to either the input of the A27 40 GHz Doubler (for frequencies above 20 GHz) or to a bypass switch contained in the A27 40 GHz Doubler near its output (frequencies up to 20 GHz). The output of the A27 40 GHz Doubler is connected to the A24 High Band Coupler and A25 High Band Detector and routes through the optional AT1 attenuator and to the front panel RF output connector.

### Lowband Path - Frequencies Below 3.2 GHz

The output of the YIG oscillator is routed to the A29 20 GHz Doubler microcircuit. In the A29 20 GHz Doubler a portion of the signal is coupled off and routed to the A6 Frac-N. A divider on the A6 Frac-N reduces the YIG frequencies of 4-8 GHz to frequencies of 250 MHz to 3.2 GHz. These frequencies are passed to the A8 Output where amplification, filtering and modulation takes place. Frequencies below 250 MHz are generated

on the A8 Output by mixing down 1000-750 MHz with a 1 GHz LO from the A7 Reference. The signal (100 kHz - 3.2 GHz) is then routed to the A23 Low Band Coupler/Detector and then is merged into the high band path by a switch in the A30 Modulation Filter microcircuit. The signal path to the front panel is dictated by model of signal generators as detailed above in the highband description.

### **Frequency Control**

Frequency accuracy and stability are established with the A9 YIG Driver, A18 CPU, A7 Reference, A5 Sampler, and A6 Frac-N. This process is commonly referred to as a Phase Lock Loop or PLL. The A18 CPU instructs the A9 YIG Driver to coarsely tune the YIG with a voltage provided by the pre-tune DAC. The A5 Sampler compares the signal from the YIG to a reference signal and generates an error voltage proportional to the frequency error. This voltage is summed with the pre-tune DAC voltage and corrects (fine tunes) the YIG's output signal.

The reference signal is provided by the A6 Frac-N VCO (Voltage Controlled Oscillator) and may be controlled by an external 10 MHz signal, an internal standard 10 MHz OCXO (Oven Controlled Crystal Oscillator) on the A7 Reference, or an optional high-stability 10 MHz OCXO. The A5 Sampler must convert the GHz range YIG frequencies to MHz range IF frequencies to make the comparison with the reference. The comparison is done by a phase detector which generates an output voltage proportional to the difference in frequency/phase. This voltage is to tune the YIG to a frequency so there is no difference in frequency/phase. When the A18 CPU coarse tunes the YIG, it also sets the A5 Sampler VCO frequency and the A6 Frac-N frequency. These VCO frequencies are not fixed and vary according to the frequency of the YIG. The A6 Frac-N's VCO is further divided by the A5 Sampler.

### **Output Power Level/Automatic Leveling Control**

Output power control circuitry consists of two detectors, an ALC assembly, and two ALC modulators. This circuitry is commonly referred to as the ALC loop. The two detectors are the A23 Low Band Coupler/Detector and the A24 High Band Coupler and A25 High Band Detector. The A23 Low Band Coupler/Detector is used for frequencies up to 2 GHz and the A24 High Band Coupler and A25 High Band Detector for frequencies above 2 GHz. Note that this is not the same frequency breakpoints as defined by the Lowband and Highband paths. The couplers provide a small portion of the RF signal to the detectors. The detectors convert the RF signal to a dc voltage that is fed to the A10 ALC. In closed loop operation, a comparison is made between a reference voltage and the detected voltage. If the detected and reference voltage levels agree, the modulator drive current remains constant. If the detected and reference levels do not agree, the modulator drive current changes causing the RF output power to increase or decrease until the reference and detected voltages agree. In open loop operation or ALC OFF mode, only the reference voltage is used to control the modulation drive current. The reference voltage is determined by the desired power setting and includes the stored calibration data used to make up for any losses that occur after the coupler/detector. The reference voltage is generated on the A10 ALC by a DAC and is controlled by the A18 CPU.

### **Analog Modulation**

The A11 Pulse/Analog Modulation Generator includes a pulse generator and a numeric synthesizer to provide AM, FM, PM, and pulse modulation capabilities. The numeric synthesizer can also be used to provide LF output signals up to 1 MHz. Modulation signals are either externally generated or internally generated using an internal waveform generator. The internal generator is tied to the 10 MHz from the A7 Reference for better phase modulation control. There is also a feature that allows internally generated signals to be switched to the LF Output BNC on the front panel. Modulation signals are provided to the A10 ALC (AM), A30 Modulation Filter and A8 Output (pulse), and Frac-N (FM and PM).



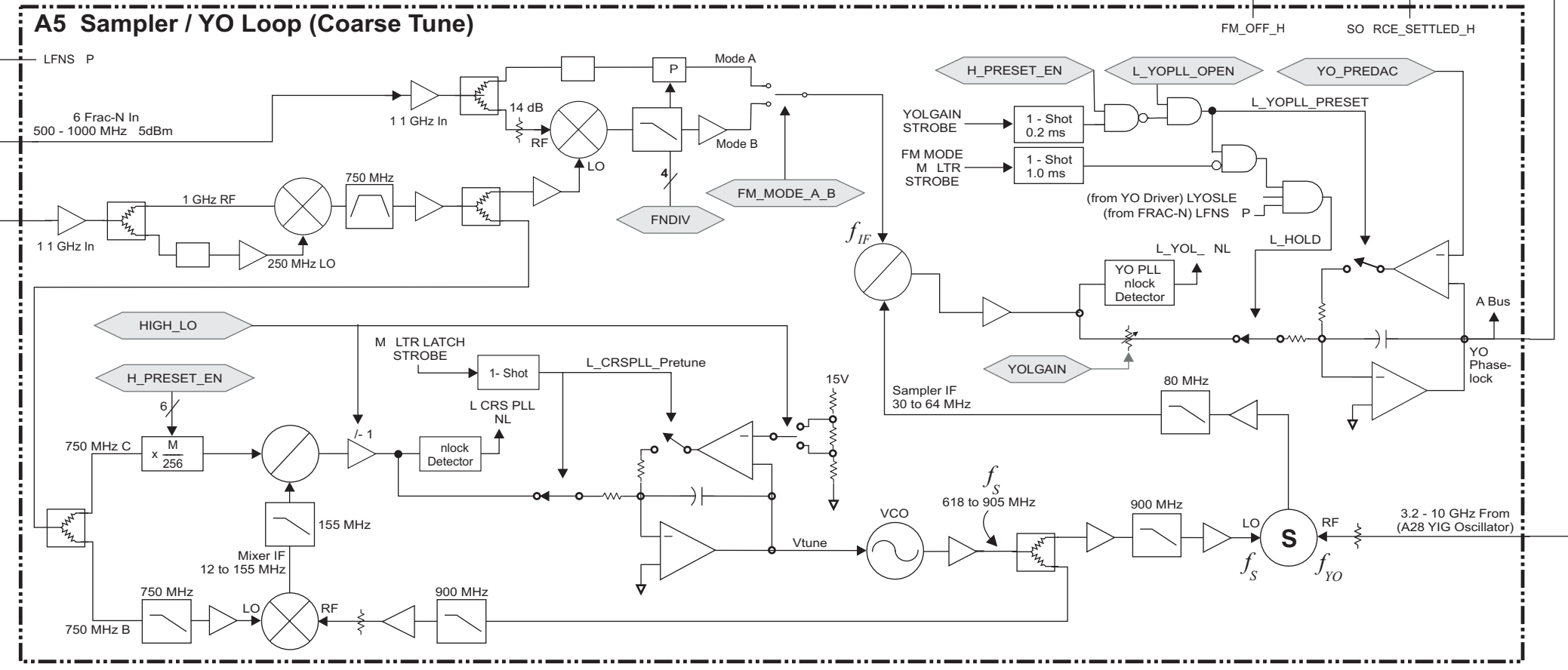
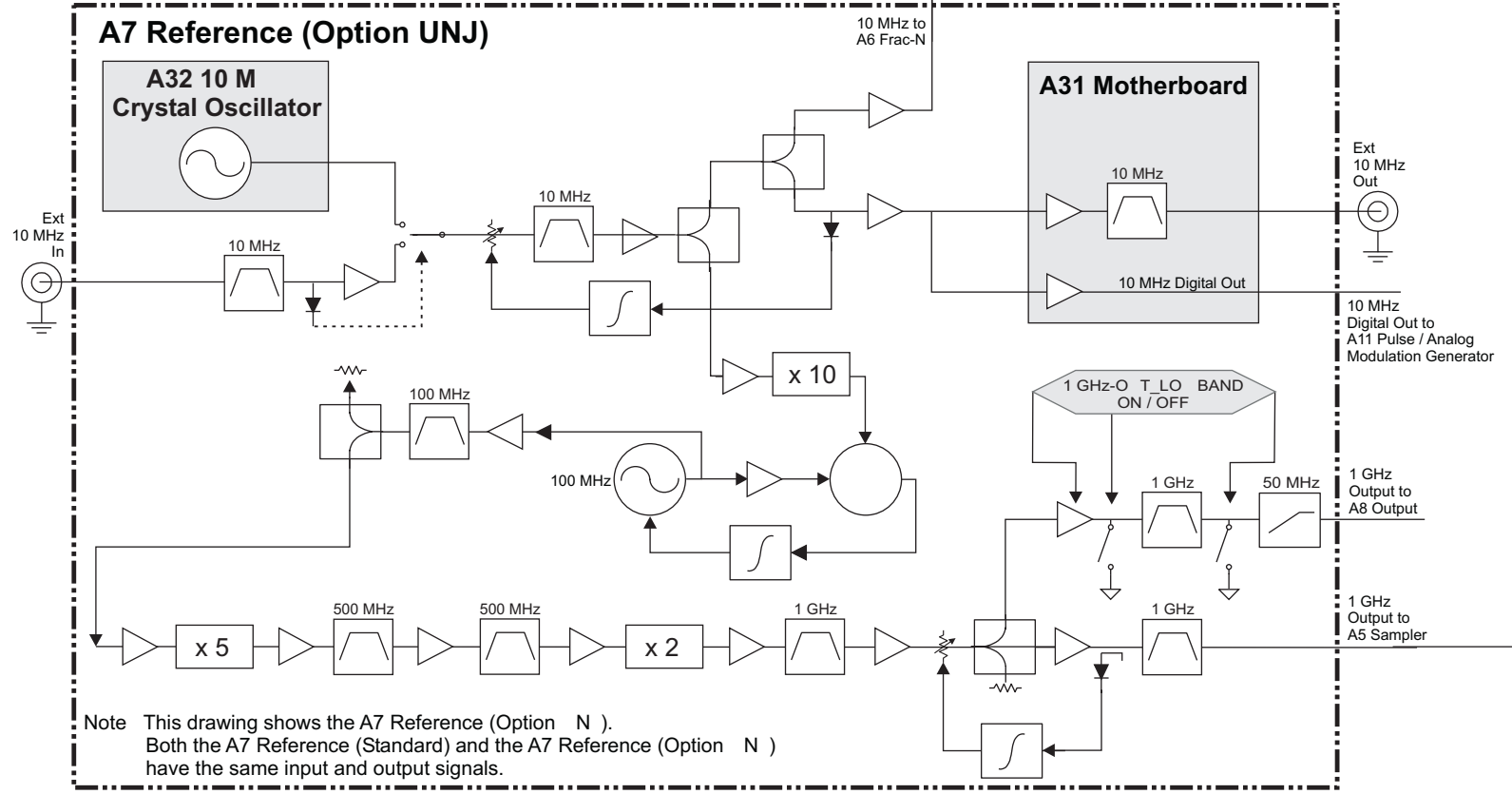
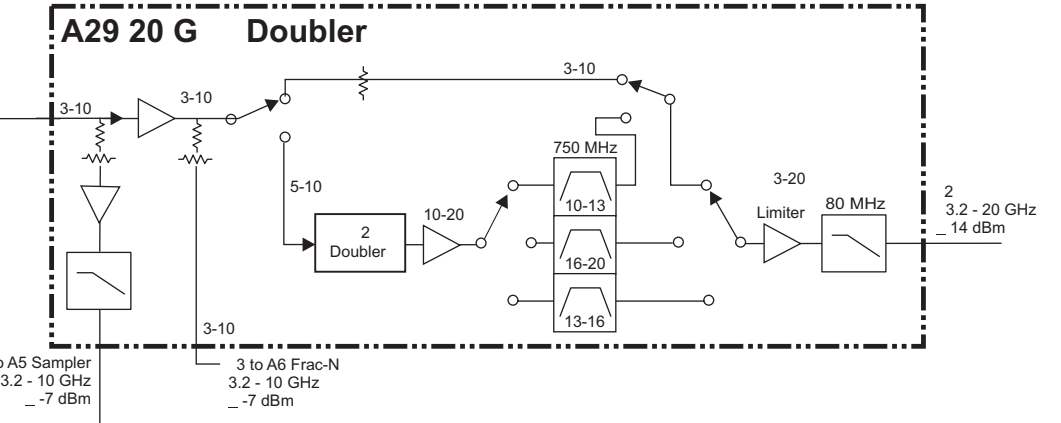
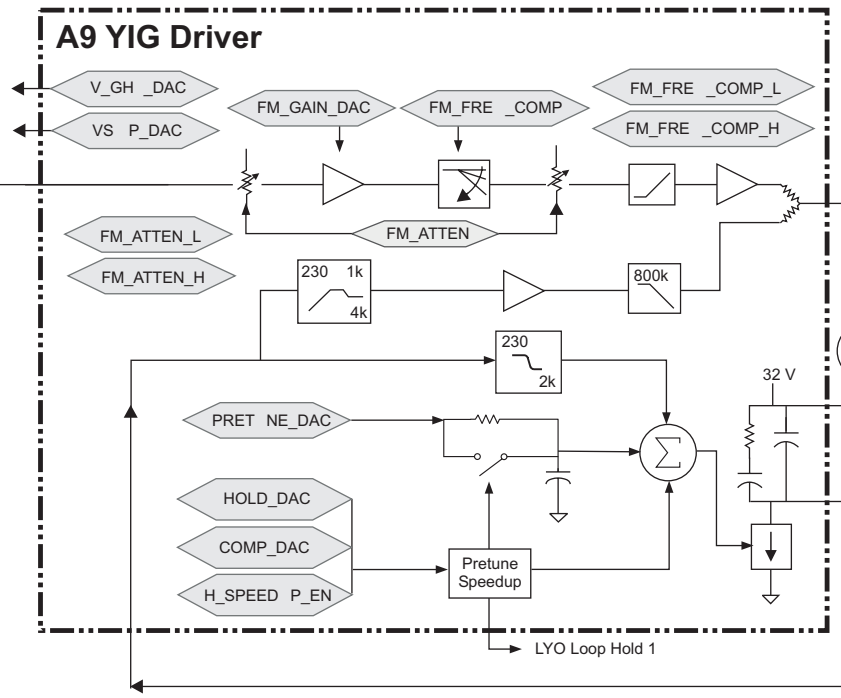
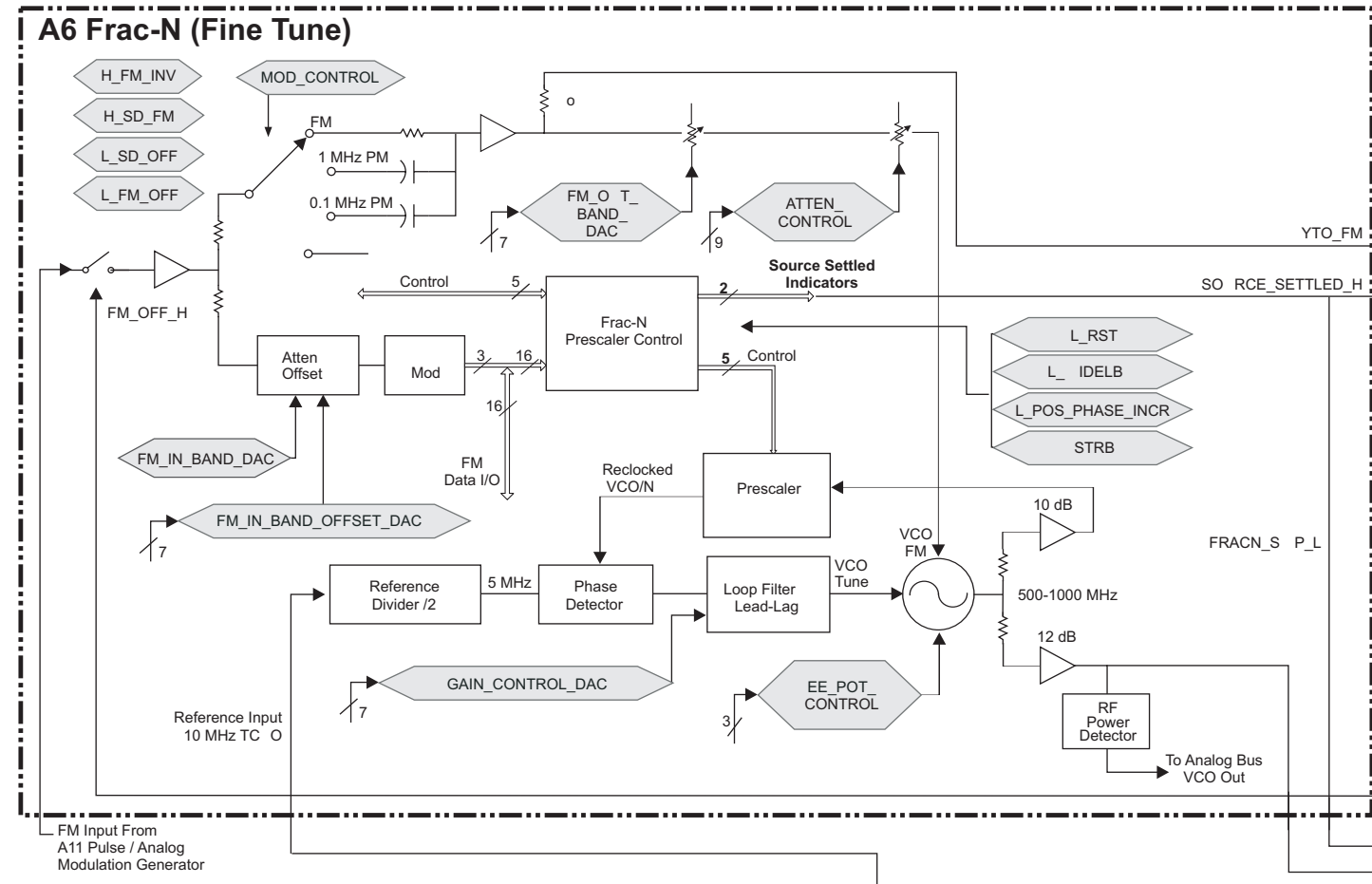

Block Diagram for the Reference / Synthesis Loop



---

## Reference/Synthesis Loop Block Description

The function of the Reference/Synthesis Loop is to establish the frequency characteristics of the signal generator. These frequency characteristics are the fundamental frequency range, phase noise, and frequency accuracy. The Reference/Synthesis loop consists of the A7 Reference, A5 Sampler, A6 Frac-N, A9 YIG Driver, YIG Oscillator (YO), and A29 20 GHz Doubler. The Reference/Synthesis Loop description covers the generation of 3.2 to 10 GHz signals and the RF Path description covers frequency generation of frequencies other than 3.2 GHz to 10 GHz.

The basic functions required to generate an accurate frequency are coarse tuning, fine tuning, and output frequency monitoring or feedback. Coarse tuning is achieved using the Pretune DACs on the A9 YIG Driver. Fine tuning is achieved using the A5 Sampler and A6 Frac-N. To help explain the operation of the Reference/Synthesis loop, the following paragraph describes what happens when a signal generator is set to a frequency of 5 GHz.

When the user enters the frequency, the A18 CPU sets the A9 YIG Driver Pretune DAC to a value that results in the YO being coarsely tuned to 5 GHz (within ~ 3 MHz). At the same time, the CPU sets the Sampler VCO and the A6 Frac-N VCO to the frequencies necessary to generate an exact 5 GHz YO output. The output of the YO is connected to the A29 20 GHz Doubler where a portion of the signal is coupled off and routed to the A5 Sampler. On the A5 Sampler, the coarsely tuned 5 GHz is converted to an IF frequency and then filtered. The A6 Frac-N VCO is divided down on the A5 Sampler to approximately the same frequency as the IF from the coarsely tuned YO signal and is used as the reference signal in the phase comparator. The output of the phase comparator is proportional to the phase (frequency) error between the two signals. This error voltage is integrated and summed with the pretune voltage, fine tuning the YO to exactly 5 GHz.

### A7 Reference

Essential to frequency accuracy and low phase noise are clean and stable reference signals. In this case, there are two reference signals required: the 1 GHz signal used by the A5 Sampler and A8 Output, and the 10 MHz signal used by the A6 Frac-N. The A7 Reference (Standard) uses a 1 GHz STW Oscillator and 10 MHz OCXO. The low phase noise A7 Reference (Option UNJ) uses a 100 MHz VCXO that is multiplied by 10 to achieve 1 GHz and a high performance 10 MHz OCXO. The A6 Frac-N uses the 10 MHz reference to maintain the A6 Frac-N's VCO phase coherency.

### A5 Sampler

The A5 Sample contains a microwave sampler, used to convert the YO output to lower frequencies for phase comparison. A portion of the YO's output is coupled to the A5 Sampler to use as the RF input to the sampler. The VCO on the A5 Sampler is used as the LO input to the sampler. The VCO output is a frequency between 618 to 905 MHz. The LO and RF signals generate an IF signal between 30 and 64 MHz. The IF signal passes through an 80 MHz low pass filter eliminating all signals above 80 MHz that may pass through the sampler. The IF signal is an input to a phase comparator. The other phase comparator input is the 10 to 80 MHz signal that is the result of dividing down or mixing the 500 to 1000 MHz signal from the A6 Frac-N VCO. The phase comparator's output is integrated and the integrated output summed with the pretune voltage on the A9 YIG Driver to fine tune the YO output to the desired frequency.

In FM OFF mode, the phase noise level is improved on the A5 Sampler by dividing down the A6 Frac-N VCO signal to get the desired frequency between 10 and 80 MHz. In FM ON mode and rates above 230 Hz, phase noise performance is not as good as in FM OFF mode because the A6 Frac-N VCO uses a mixer to get the desired frequency between 10 and 80 MHz. The mixer circuit is needed to allow for higher FM rates.

## **A6 Frac-N**

One function of the A6 Frac-N is to provide a means to set the YIG Oscillator to any frequency. This is accomplished on the A6 Frac-N by using a dividing technique that can set the A6 Frac-N VCO signal to any frequency. The A6 Frac-N VCO output is used as the phase reference for the comparator on the A5 Sampler. Small changes in the divide number result in small changes in the A6 Frac-N VCO output frequency and small changes in the YIG Oscillator frequency.

In FM mode, rates 230 Hz and below, FM is accomplished by combining the FM signal and the VCO tune signal and driving the main coil. For rates above 230 Hz, FM is accomplished using the FM coil circuit on the A9 YIG Driver and the FM coil in the YIG Oscillator.

## **A9 YIG Driver**

The function of the A9 YIG Driver is to provide the YIG oscillator with the correct power supply and turn voltages. Coarse tuning is achieved by the A18 CPU setting the pretune DACs to the value needed to tune the YIG oscillator close to the desired frequency. Correction voltage from the A5 Sampler is summed with the pretune voltage on the A9 YIG Driver to fine tune the YIG oscillator. For higher rate FM operation, the FM signal is scaled and the gain calibrated on the A9 YIG Driver before being used to drive the FM coil in the YIG oscillator.

## **A28 YIG Oscillator (YO)**

The YIG oscillator (YO) output frequency is controlled by the amount of current through the main and FM coils. The main coil is used for setting CW frequencies and for FM rates 230 Hz and below. The FM coil is used for rates greater than 230 Hz. The YO operates over a frequency range of 3.2 GHz to 10 GHz.

## **A29 20 GHz Doubler**

Internal to the A29 20 GHz Doubler are two couplers used to pick off some of the 3.2 to 10 GHz signal. One coupled output is routed to the A6 Frac-N and the other coupled output is routed to the A5 Sampler. The signal to the A5 Sampler provides the feedback needed to generate the fine tune correction voltage used to control the accuracy of the YIG oscillator frequency.



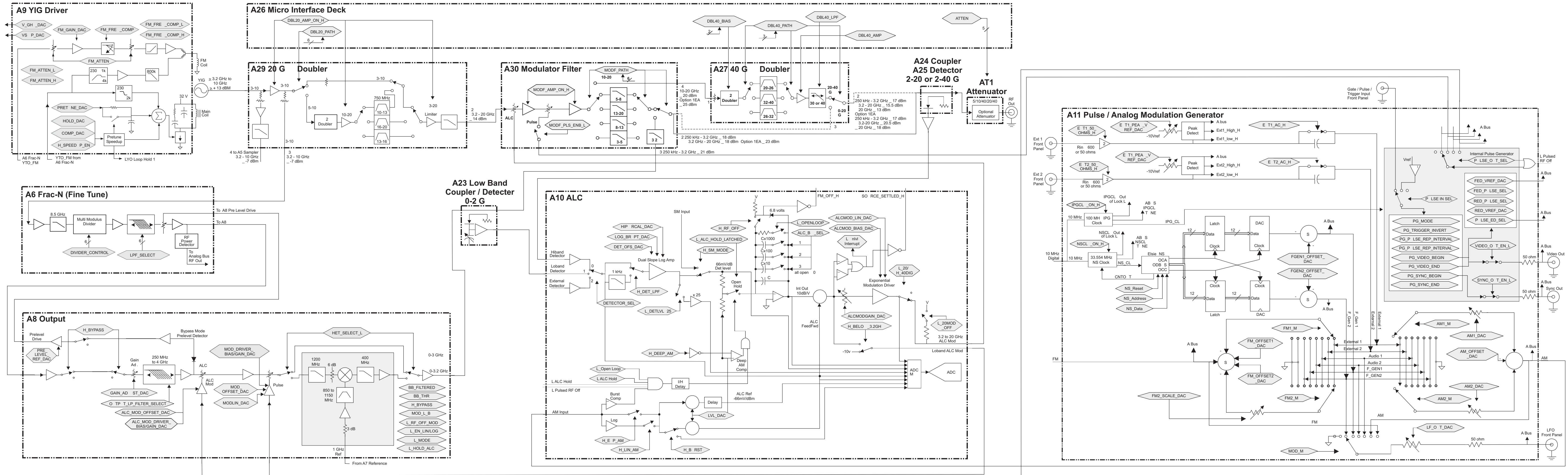

Block Diagram for the RF Path



---

## RF Path Block Description (Frequency Generation, Level Control, and Modulation)

### Frequency Generation

The RF is used to generate, modulate and control the level of the output frequencies. The Synthesis Loop Block Description describes how the fundamental frequencies of 3.2 GHz to 10 GHz are generated using the YO, Sampler, and Frac-N. Frequencies below 3.2 GHz are generated by dividing down the fundamental frequency. Output frequencies between 3.2 and 10 GHz are the RF fundamental frequencies generated by the YIG Oscillator. Output frequencies of 10 and 20 GHz are generated by doubling the 5 to 10 GHz fundamental frequency. Output frequencies above 20 GHz are generated by doubling the 10 to 20 GHz frequencies. The RF Path consists of the A29 20 GHz Doubler, A6 Frac-N, A8 Output, A30 Modulation Filter, and A27 40 GHz Doubler.

### A29 20 GHz Doubler

Besides providing signal to the A5 Sampler as discussed in Synthesis Loop overview, the A29 20 GHz Doubler is a key part of the RF path. For output frequencies below 3.2 GHz, the A29 20 GHz Doubler provides RF input to the A6 Frac-N. For output frequencies 3.2 to 10 GHz, the A29 20 GHz Doubler passes through the YIG Oscillator frequencies. For output frequencies of 10 to 20 GHz, the A29 20 GHz Doubler doubles the 5 to 10 GHz fundamental. For frequencies 3.2 GHz and above, the A29 20 GHz Doubler output is routed to the A30 Modulation Filter.

### A6 Frac-N

The A6 Frac-N is part of the Synthesis Loop and the RF path. Frequencies below 3.2 GHz are generated on the A6 Frac-N by dividing down the fundamental frequency. Frequencies above 3.2 GHz do not go through the A6 Frac-N. On the A6 Frac-N, the RF signal from the A29 20 GHz Doubler is amplified, filtered, divided, and then amplified again before being routed to the A8 Output.

A pre-level bias voltage from the A8 Output is fed back to the A6 Frac-N to maintain the desired RF output level from the A6 Frac-N to the A8 Output. If the A8 Output is removed from the signal generator while the signal generator is powered on, the correct bias is maintained and the RF power level to the A8 Output can be checked.

### A8 Output

The A8 Output provides pre-level bias voltage to the A6 Frac-N, RF output leveling control, pulse modulation, and amplitude modulation, and frequency under range circuitry. The ALC diode is used to control the RF output power for frequencies up to 3.2 GHz. With no bias applied to the ALC diode output power goes to the minimum level the circuit can provide. In closed loop operation, the A10 ALC uses a negative voltage from the detectors to maintain the bias on the ALC diode. Pulse modulation (RF pulsed on) is achieved by applying a +5 Vdc to the pulse circuitry on the A8 Output. Under range frequencies below 250 MHz are generated on the A8 Output by mixing the RF signal with a 1 GHz signal from the A7 Reference. The A8 Output signals pass through the A23 Low Band Coupler/Detector before going to the A30 Modulation Filter.

## A30 Modulation Filter

The A30 Modulation Filter's frequency output is from 100 kHz to 20 GHz. Frequencies below 3.2 GHz are switched through the A30 Modulation Filter and are not filtered or modulated in the assembly. The A30 Modulation Filter provides level control, pulse modulation, amplitude modulation, and filtering for frequencies 3.2 GHz and above. The ALC diode is used to maintain level control. With not bias applied to the ALC diode, output goes to the maximum power level the circuit can produce. In pulse operation, the pulse diode is biased on for an RF signal to pass through. If an A11 Pulse/Analog Modulation Generator is installed and a bias is not applied to the pulse diode, no RF signal will pass through. Since the same A30 Modulation Filter is used in all models, if an A11 Pulse/Analog Modulation Generator is not installed, circuitry on the A30 Modulation Filter biases the pulse diode on.

In a 20 GHz signal generator the A30 Modulation Filter output is routed to the A24 High Band Coupler and A25 High Band Detector. If a 40 GHz Doubler is installed, two A30 Modulation Filter outputs are routed to the A27 40 GHz Doubler.

## A27 40 GHz Doubler

The 40 GHz Doubler is used to produce frequencies between 20 and 40 GHz. The 40 GHz Doubler has two inputs from the A30 Modulation Filter. One input is used for frequencies below 20 GHz and one for frequencies above 20 GHz. Frequencies below 20 GHz pass through the A27 40 GHz Doubler. Frequencies 20 GHz and above are generated by doubling the A30 Modulation Filter's 10 to 20 GHz input. After being doubled, band pass filters are used to eliminate unwanted harmonics. The 40 GHz output is routed to the A24 High Band Coupler and A25 Detector.

## A23 Low Band Coupler/Detector, A24 High Band Coupler, and A25 High Band Detector

The function of the coupler is to couple off a portion of the RF signal. The detector is used to convert the RF signal to a dc voltage. The dc voltage is then routed to the A10 ALC. The RF signal out of the A23 Low Band Coupler/Detector is routed to the A30 Modulation Filter. The RF signal out of the A24 High Band Coupler and A25 High Band Detector is routed to either the optional attenuator or the RF output connector. The A23 Low Band Coupler/Detector is a single unit and the coupler and detector must be changed together. The A24 High Band Coupler and A25 High Band Detector are two separate units and can be changed independently. The A23 Low Band Coupler/Detector is used for frequencies 2 GHz and below. The A24 High Band Coupler and A25 High Band Detector are used for frequencies above 2 GHz.

## ALC Loop

The function of the ALC loop is to maintain power level accuracy by measuring the output power and compensating for deviations from the set power level. The A23 Low Band Coupler/Detector and the A24 High Band Coupler and A25 High Band Detector detect the output power level, compare the detected voltage to a reference, and adjust the modulator diodes (located on the A8 Output and A30 Modulation Filter) to achieve the desired power level.

## A10 ALC

In ALC ON operation, the A10 ALC integrates the detected and reference voltages and adjusts the drive to the modulator diodes until both the reference and detected voltages agree. The low and high band detectors provide the detected voltage to the A10 ALC. The reference voltage is determined by the A18 CPU setting DACs on the A10 ALC. The detected and reference voltages are the input to an integrator. When the inputs to the integrator are equal the output ramps in either direction changing the modulator diode drive level. Once the detected voltage equals the reference voltage the output of the integrator remains at a constant level.

ALC ON operation is referred to as a closed loop operation because the output signal level is continually monitored and used to adjust the modulator drive resulting unlevelled output power.

In ALC OFF mode, the feedback path, the detected voltage path is opened and only the reference voltage is used to set the output power level. Because the feedback path is open, ALC OFF mode is referred to as open loop operation. With the modulator level is set to a fixed drive level and without the output level being monitored, the RF output level will vary.

In external leveling operation, internal detector voltages are replaced with an external detector voltages. The external detector must be a negative detector to provide the correct signal to the A10 ALC. Leveling accuracy is a function of the detector and instrument calibration. Since the instrument is calibrated with internal detectors, leveling accuracy in external mode is dependent on the detector being used.

The ALC circuit is temperature compensated to provide leveled performance over a specified temperature range, The high band diode temperature sensing circuit is located on the RF deck on the A24 High Band Coupler and A25 High Band Detector. A resistor pack is used to calibrate the high band detector performance over temperature. If the A25 Detector is replaced, the resistor pack provided with the detector must also be installed to maintain maximum performance. The low band detector can not be replace independently of the coupler, so temperature compensation is contained within the assembly. Although rare, unstable level performance can be the result of problems with poorly soldered resistors on the resistor pack or with other components in the temperature compensation circuit.

## **Modulation (AM, FM, PM, and Pulse)**

Modulation features apply only to analog versions of signal generators. The A11 Pulse/Analog Modulation Generator provides modulation signals for AM, FM, pulse, and phase. A dual function generator is built onto the A11 Pulse/Analog Modulation Generator and tied to the 10 MHz reference from A7 Reference for phase synchronization. Pulse Input, EXT1, and EXT2 provide external modulation input connections. A low frequency output (LF Output) connector located on the front panel can be selected to output the signal generated by the A11 Pulse/Analog Modulation Generator to drive other instruments. SYNC OUT and VIDEO OUT signals are also generated on the A11 Pulse/Analog Modulation Generator.

EXT 1 and EXT 2 inputs have modulation drive level detection circuits and generate error messages if too small or too large of a signal is applied to the input. EXT 1 and EXT 2 can be set for 50 or 600 ohms input impedance and can be configured for dc or ac coupling. The FM/PM modulation signal is routed to the A6 Frac-N. FM rates of less than 4 kHz are applied to both prescale circuit for the A6 Frac-N VCO and to the A6 Frac-N VAC's tune voltage to achieve FM. The prescale circuit modifies the VCO feedback signal to the VCO phase detector causing a change in the VCO frequency. FM rates of 4 kHz to 100 kHz are applied to the A6 Frac-N VCO. FM rates above 100 kHz are routed from the A6 Frac-N to the A9 YIG Driver and applied to the FM coil in the YIG Oscillator. Phase modulation is achieved by applying the same signal used for FM to the A6 Frac-N, where the signal goes through an added LCR circuit for PM. The modulation signal is then routed in the same manner as when FM is used.

The AM signal is routed to the ALC where it is summed with the ALC reference voltage and applied to the Modulation Filter and Output ALC diodes. Pulse modulation signals are routed directly to the Output and the Modulation Filter pulse diodes. Pulse diodes must be biased on for RF to pass through. Because the ALC bandwidth is limited, the ALC cannot properly level the RF output with pulse widths of <1 microsecond. To compensate for leveling limitations at faster pulse rates, Search Mode operation has been added. In Search Mode, the signal generator turns off all modulation, levels the power using closed loop operation (feedback), then opens the loop and levels using the leveling voltage determined during closed loop operation. Changes in power level, frequency, or pulse settings will cause the signal generator to turn modulation off, level the power with the new settings, then open the loop and turn modulation back on. Because drift in level circuits with out feedback control can occur over time, it is not recommended to leave Search mode on for extended periods without closing the loop and resetting the leveling voltage.

## Self-Test Overview

### Philosophy

The philosophy of self-test is, "It is better to pass a defective signal generator than to fail a good signal generator. Self-tests are designed as a diagnostic tool used to check signal generator hardware. Self-tests do not require the signal generator to be calibrated before self-tests will pass. This philosophy implies that some failures will not be detected and reported as bad, but will pass. If the signal generator powers on and self-tests can be run, troubleshooting should always start by running self-tests and resolving reported problems first.

### Overview

Embedded in the signal generator's firmware is a group of tests (self-tests) that can be used to evaluate the condition of the circuitry on many of the assemblies. Self-tests check hardware performance under controlled conditions and compare test results to predetermine limits. If the results fall within the limits the signal generator passes. If one or more test results fall outside the limits, the self-test routine evaluates the failures and reports the most independent failure.

### How self-test works:

1. When the signal generator is tested at the factory, self-test limits are loaded into the A18 CPU memory from devices on each assembly or from fixed files. Most assemblies contain limit information while microcircuit limits must be loaded.
2. When the program runs, latches and DACs are set to a known state.
3. An analog mux routes the detected dc signal from the selected rest node to the A18 CPU.
4. The A18 CPU compares the detected dc level to the test limit. If the detected value is within the limits, the A18 CPU reports a pass.
5. If one or more detected values fall outside the limits, the most independent failure is determined and reported.

### Independent failures

Independent failures can best be understood by using an example. There are three assemblies in a series. A1 is the first assembly, A2 the second assembly, and A3 the third assembly. A1 output is the input for A2 and A2 output is the input for A3. If A1 output is bad, A2 and A3 outputs are also bad. If A2 output is bad, A3 output is bad. A file in the signal generator contains this dependency knowledge for the signal generator to use to identify the most independent failure. If A1, A2, and A3 self-tests all fail, the signal generator reports A1 as the most independent failure. If A1 passes but A2 and A3 fail, self-test reports A2 as the most independent failure. If A2 passes and A3 fails, self-test reports A3 as the most independent failure. If two independent failures occur, self-test reports only one failure at a time and reports the second failure after the first reported failure is repaired.

The troubleshooting procedure is based on the most independent failure and no lower level information is needed. Although not needed for troubleshooting the signal generator, the self-test overhead provides features to view lower level detailed information about the subroutines and select specific routines to run. These features include:

- Select/Deselect Test
- Select/Deselect All
- View Details
- Run Highlighted Tests

- Run Selected Tests
- When View Details is selected, the measured value, lower, and upper limits are displayed on the highlighted test.

## Contacting Agilent Technologies

If you should have a problem with your signal generator, contact your nearest sales and service offices. Before calling, please be prepared to provide the following information:

- a complete description of the failure
- is there a reported failure (Y or N) and what is the failure being reported
- was the failure dead on arrival (DOA) or did the instrument work before use
- the model number, all options, and serial number of the instrument
- the firmware revision date
- has self-test been run (Y or N)

### Review the Warranty

If there is still a problem, read the warranty printed in Chapter 5. If your signal generator is covered by a separate maintenance agreement, be familiar with its terms.

Agilent Technologies offers several maintenance plans to service your signal generator after warranty expiration. Call your Agilent Technologies sales and service office for full details.



## Contacting Agilent Sales and Service Offices

Before contacting Agilent, read the warranty printed in Chapter 5. If your signal generator is covered under a main ten ace agreement, be familiar with its terms.

Sales and service offices are located around the world to provide complete support for your signal generator. To obtain servicing information, contact the nearest Agilent Sales and Service office listed in [Table 1-44](#). For information on ordering parts refer to Chapter 3.

By internet, phone, or fax, get assistance with all your test and measurement needs.

**Table 1-44 Contacting Agilent**

**Online assistance:** [www.agilent.com/find/assist](http://www.agilent.com/find/assist)

<b>United States</b> (tel) 1 800 452 4844	<b>Latin America</b> (tel) (305) 269 7500 (fax) (305) 269 7599	<b>Canada</b> (tel) 1 877 894 4414 (fax) (905) 282-6495	<b>Europe</b> (tel) (+31) 20 547 2323 (fax) (+31) 20 547 2390
<b>New Zealand</b> (tel) 0 800 738 378 (fax) (+64) 4 495 8950	<b>Japan</b> (tel) (+81) 426 56 7832 (fax) (+81) 426 56 7840	<b>Australia</b> (tel) 1 800 629 485 (fax) (+61) 3 9210 5947	

### Asia Call Center Numbers

Country	Phone Number	Fax Number
Singapore	1-800-375-8100	(65) 836-0252
Malaysia	1-800-828-848	1-800-801664
Philippines	(632) 8426802 1-800-16510170 (PLDT Subscriber Only)	(632) 8426809 1-800-16510288 (PLDT Subscriber Only)
Thailand	(088) 226-008 (outside Bangkok) (662) 661-3999 (within Bangkok)	(66) 1-661-3714
Hong Kong	800-930-871	(852) 2506 9233
Taiwan	0800-047-866	(886) 2 25456723
People's Republic of China	800-810-0189 (preferred) 10800-650-0021	10800-650-0121
India	1-600-11-2929	000-800-650-1101

In any correspondence or telephone conversation, refer to the signal generator by its model number and full serial number. With this information, the Agilent representative can determine whether your unit is still within its warranty period.

### Important Information Needed by an Agilent Service Representative

Be as specific as possible about the nature of the problem and include information such as:

- any error messages that appeared on the signal generator
- a complete performance test record from the calibration guide for your signal generator
- any other specific data on the performance of the signal generator

## Returning Your Signal Generator for Service

Use the information in this section if you need to return the signal generator to Agilent Technologies.

### Packaging the Signal Generator

1. Use the original packaging materials or a strong shipping container that is made of double-walled, corrugated cardboard with 159 kg (350 lb.) bursting strength. The carton must be both large enough and strong enough to accommodate the signal generator and allow at least 3 to 4 inches on all sides of the signal generator for packing material.

---

**CAUTION** Signal generator damage can result from using packaging materials other than those specified. Never use styrene pellets, in any shape, as packaging materials. They do not adequately cushion the instrument or prevent it from shifting in the carton. Styrene pellets cause equipment damage by generating static electricity and by lodging in the signal generator fan.

---

2. Surround the instrument with at least 3 to 4 inches of packing material, or enough to prevent the instrument from moving in the carton. If packing foam is not available, the best alternative is SD-240 Air Cap™ from Sealed Air Corporation (Hayward, CA 94545). Air Cap looks like a pink plastic sheet covered with 1-1/4 inch air-filled bubbles. Use the Air Cap to reduce static electricity. Wrap the instrument several times in the material to both protect the instrument and prevent it from moving in the carton.
3. Seal the shipping container securely with strong, nylon adhesive tape.
4. Mark the shipping container “FRAGILE, HANDLE WITH CARE” to ensure careful handling.
5. Retain copies of all shipping papers.

---

## **2 Assembly Replacement**

## Before You Replace an Assembly

---

**CAUTION** Many of the assemblies in this instrument are very susceptible to damage from electrostatic discharge (ESD). Perform service procedures only at a static-safe workstation and wear a grounding strap.

---

Be sure to review the warning and caution statements described in [Chapter 55, "Safety and Regulatory," on page 5-1](#), prior to replacing an assembly in your signal generator.

## After Replacing or Repairing an Assembly

After you have replaced or repaired an assembly, certain performance tests and adjustments may have to be performed. Please refer to [Chapter 54, "Post-Repair Procedures," on page 5-1](#), for the list of performance tests and adjustments required for each assembly.

## Assemblies That You Can Replace

- "Outer Instrument Cover" on page 2-4
- "Inner Instrument Cover" on page 2-6
- "Front Panel" on page 2-8
- "A1 Keyboard" on page 2-10
- "A2 Display" on page 2-12
- "A2DS1 Display Backlight" on page 2-14
- "A3 Power Switch" on page 2-16
- "A4 Inverter" on page 2-18
- "A5 Sampler" on page 2-20
- "A6 Frac-N" on page 2-22
- "A7 Reference (Standard and Option UNJ)" on page 2-24
- "A8 Output" on page 2-26
- "A9 YIG Driver" on page 2-28
- "A10 ALC" on page 2-30
- "A11 Pulse/Analog Modulation Generator" on page 2-32
- "A18 CPU" on page 2-34
- "A18BT1" on page 2-36
- "A19 Power Supply" on page 2-38
- "Rear Panel" on page 2-40
- "A20 SMI (Source Module Interface)" on page 2-42
- "A21 Rear-Panel Interface" on page 2-44
- "A22 Line Module" on page 2-46
- "AT1 115 dB Attenuator (Option 1E1)" on page 2-48
- "A23 Low Band Coupler/Detector" on page 2-50
- "A24 20 GHz High Band Coupler (E8241A and E8251A Models Only)" on page 2-52
- "A24 40 GHz High Band Coupler (E8244A and E8254A Models Only)" on page 2-54
- "A25 20 GHz High Band Detector with A25B Detector Bias Board (E8241A and E8251A Models Only)" on page 2-56
- "A25 40 GHz High Band Detector with A25B Detector Bias Board (E8244A and E8254A Models Only)" on page 2-58
- "A26 MID (Microcircuit Interface Deck)" on page 2-60
- "A27 40 GHz Doubler (E8244A and E8254A Models Only)" on page 2-62
- "A28 YIG Oscillator" on page 2-64
- "A29 20 GHz Doubler" on page 2-66
- "A30 Modulation Filter (Standard and Option 1EA)" on page 2-68
- "A31 Motherboard" on page 2-70
- "A32 10 MHz Crystal Oscillator (Option UNJ)" on page 2-72
- "B1 Fan" on page 2-74

## Outer Instrument Cover

### Tools Required

- T-15 driver
- T-20 driver

### Removal Procedure

Refer to Figure 2-1 for this procedure.

1. Disconnect the power cord.
2. Using the T-20 driver, loosen and remove the two screws (1) and remove the strap handle (2).
3. Using the T-15 driver, remove the center screws (3) from the four rear-panel feet (4).
4. Remove the four bottom feet (5) from the cover by lifting the tab and sliding the foot toward the tab.
5. Place the signal generator on its side.
6. Tilt the signal generator forward (6) and slide (7) the outer cover (8) back to remove it from the frame.

### Replacement Procedure

- Reverse the order of the removal procedures.
- Torque all T-15 screws to 21 in-lbs.
- Torque all T-20 screws to 21 in-lbs.

Figure 2-1 Outer Instrument Cover Removal

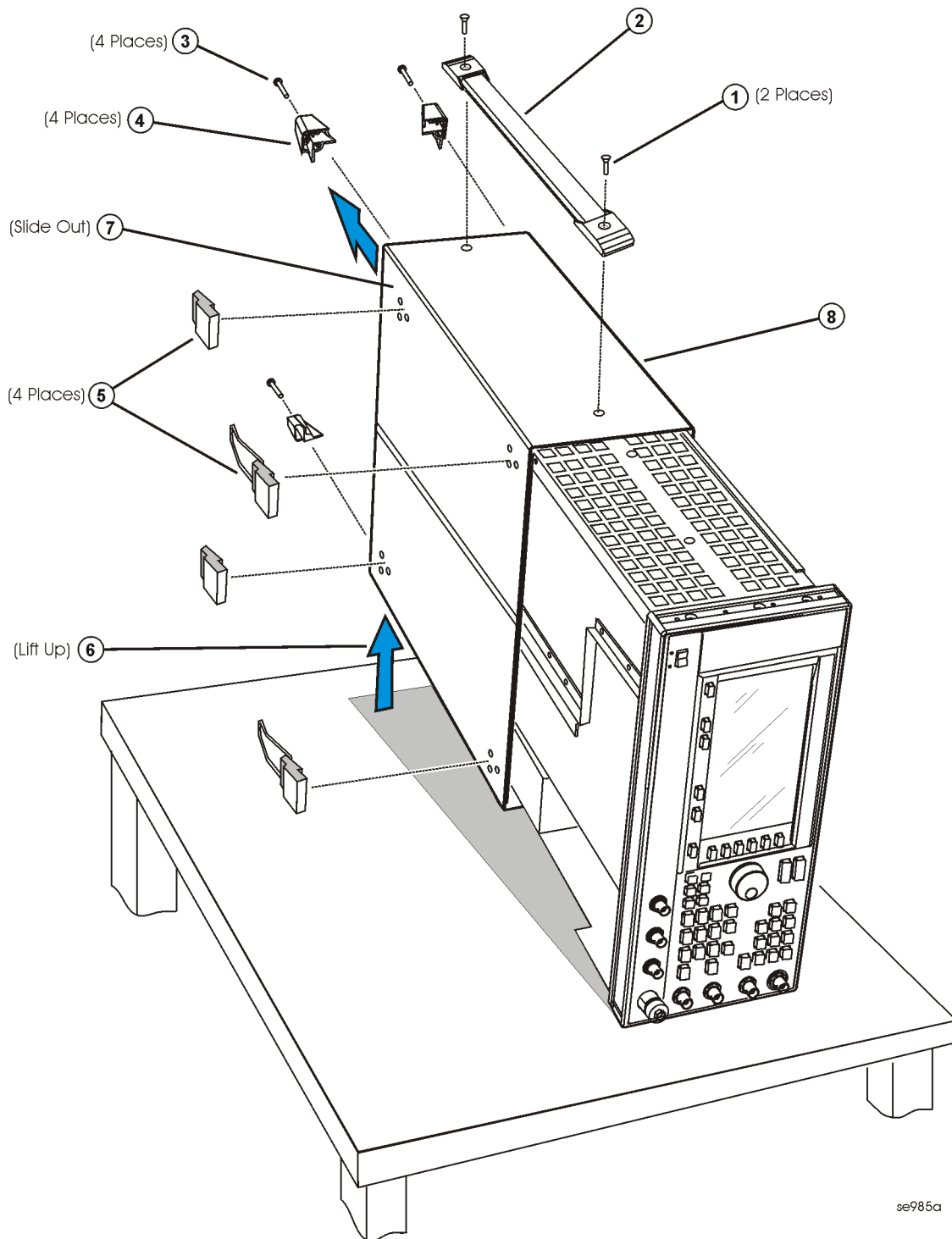

## Inner Instrument Cover

### Tools Required

- T-10 driver

### Removal Procedure

Refer to Figure 2-2 for this procedure.

1. Disconnect the power cord.
2. Remove the outer-cover from the signal generator. Refer to "[Outer Instrument Cover](#)" on page 2-4.
3. Place the signal generator flat and upright with the front panel facing you.
4. Using the T-10 driver, remove the twelve screws (1) from the inner cover (2).
5. Remove the inner cover.

### Replacement Procedure

- Reverse the order of the removal procedures.
- Torque all T-10 screws to 9 in-lbs.



Figure 2-2 Inner Instrument Cover Removal

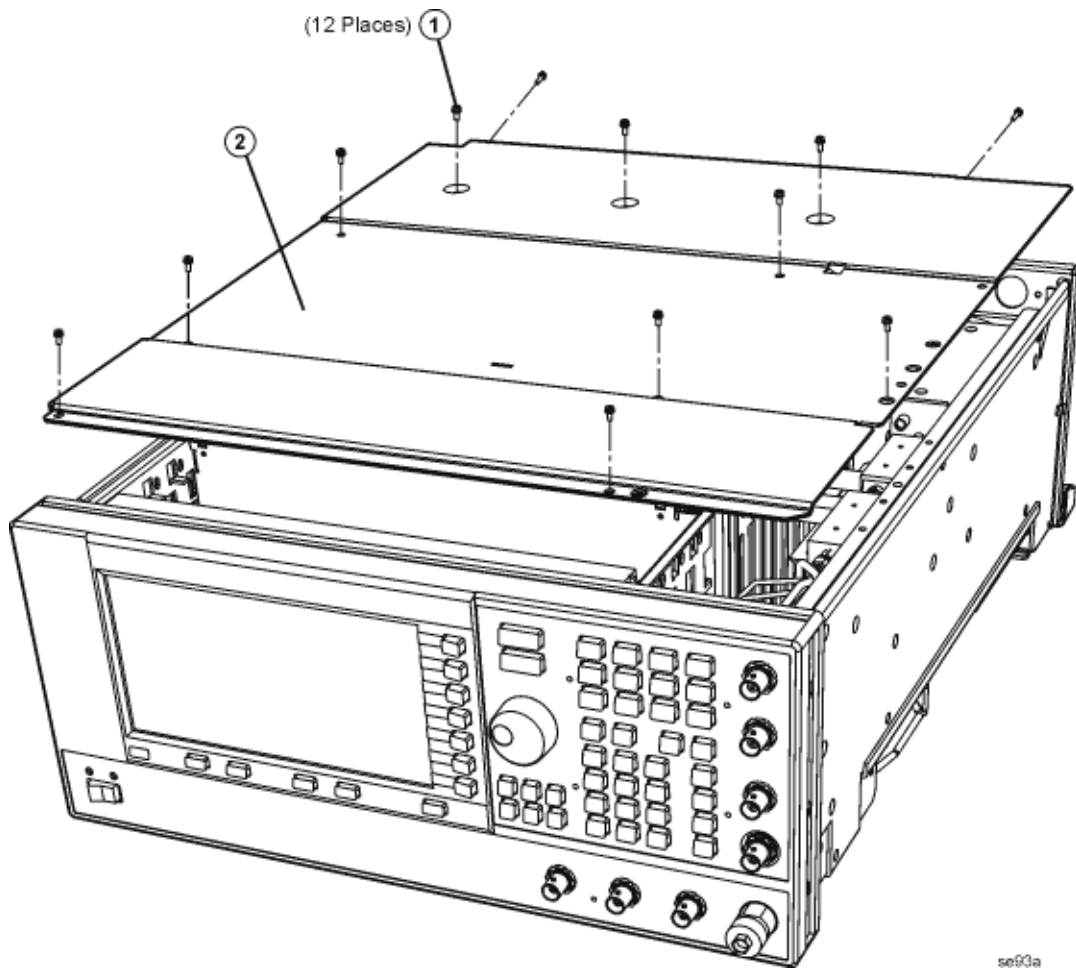

se93a

## Front Panel

### Tools Required

- T-10 driver
- T-15 driver
- needle-nose pliers

### Removal Procedure

Refer to Figure 2-3 for this procedure.

1. Disconnect the power cord.
2. Remove the covers from the signal generator. Refer to ["Outer Instrument Cover" on page 2-4](#) and ["Inner Instrument Cover" on page 2-6](#).
3. Remove the side trims that cover the six screws (1).
4. Using the T-15 driver, remove the six screws (1) from the sides of the frame.
5. Using the T-10 driver, remove one screw on the top (2) and bottom (3) frame.

---

**CAUTION** Before removing the front panel from the signal generator, lift and support the front of the signal generator's frame.

---

6. Slide the front panel over the RF output connector.
7. Disconnect the A1W1 display cable from the A31 Motherboard P13.
8. Disconnect the A4W1 inverter cable from the A31 Motherboard P12.
9. Disconnect the W9 ribbon cable from the A31 Motherboard P11.
10. Using the needle-nose pliers, disconnect the W1 cable (EXT 1 INPUT) from the A11 Pulse/Analog Modulation Generator J401.
11. Using the needle-nose pliers, disconnect the W2 cable (EXT 2 INPUT) from the A11 Pulse/Analog Modulation Generator J402.
12. Using the needle-nose pliers, disconnect the W3 cable (LF OUTPUT) from the A11 Pulse/Analog Modulation Generator J403.
13. Using the needle-nose pliers, disconnect the W4 cable (ALC INPUT) from the A10 ALC J4.
14. Using the needle-nose pliers, disconnect the W5 cable (PULSE/TRIGGER GATE INPUT) from the A11 Pulse/Analog Modulation Generator J201.
15. Using the needle-nose pliers, disconnect the W6 cable (PULSE VIDEO OUTPUT) from the A11 Pulse/Analog Modulation Generator J203.
16. Using the needle-nose pliers, disconnect the W7 cable (PULSE SYNC OUTPUT) from the A11J202.
17. Remove the front panel.

## Replacement Procedure

- Reverse the order of the removal procedure.
- Torque all T-10 screws to 9 in-lbs.
- Torque all T-15 screws to 21 in-lbs.
- Perform the post-repair adjustments and performance tests that pertain to this removal procedure.

Figure 2-3 Front Panel Removal

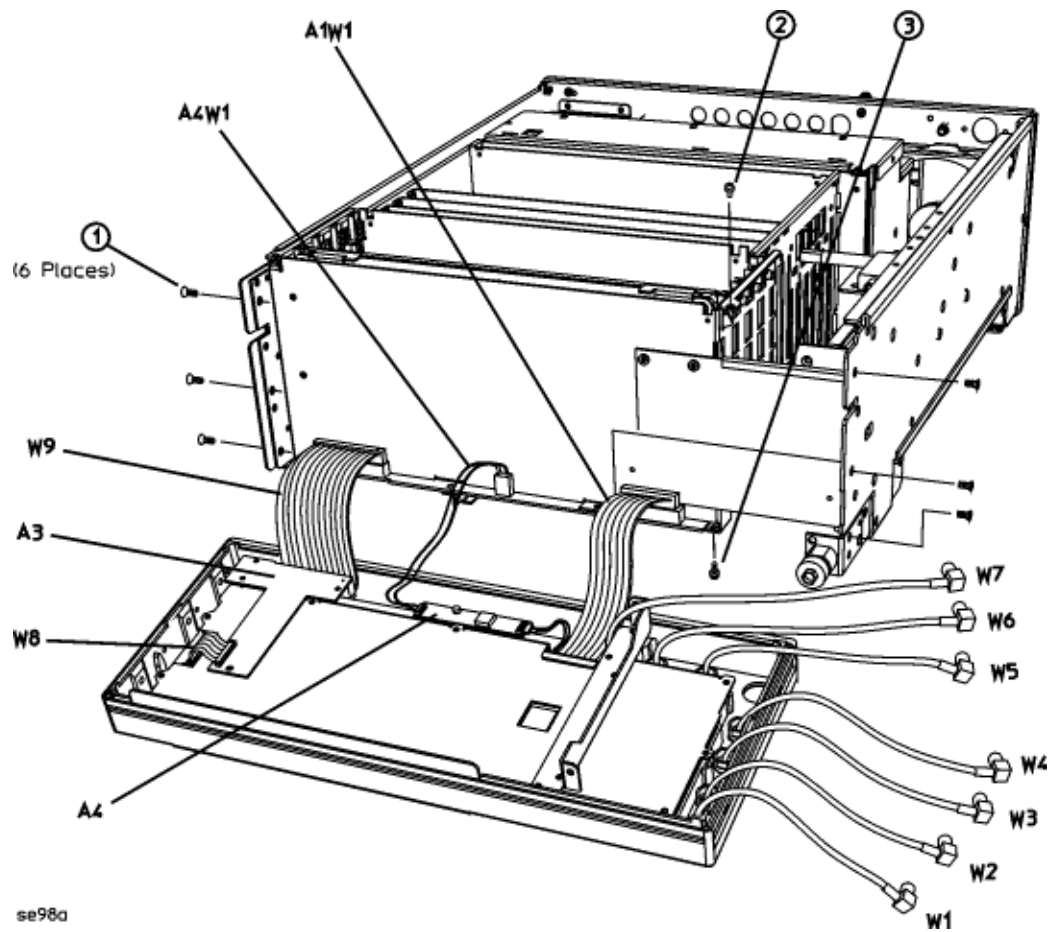

## A1 Keyboard

### Tools Required

- T-10 driver

### Removal Procedure

Refer to Figure 2-4 for this procedure.

1. Disconnect the power cord.
2. Remove the front panel. Refer to ["Front Panel" on page 2-8](#).
3. Disconnect the A2DS1W1 cable from the A4 Inverter.
4. Disconnect the W8 ribbon cable from the A3 Power Switch by lifting the white tabs on the connector.
5. Using the T-10 driver, remove the four screws (12) from the A3 Power Switch.
6. Remove the A3 Power Switch.
7. Using the T-10 driver, remove the ten screws (11) that secure the RFI shielding (10) to the front panel.
8. Remove the metal shielding.
9. Using the T-10 driver, remove the four screws (9) that secure the A2 Display to the front panel.
10. Remove the A2 Display.
11. Using the T-10 driver, remove the nine screws (8) that secure the A1 Keyboard to the front panel.
12. Remove the A1 Keyboard.

### Replacement Procedure

- Reverse the order of the removal procedures.
- Torque all T-10 screws to 9 in-lbs.
- Perform the post-repair adjustments and performance tests that pertain to this removal procedure.

Figure 2-4 A1 Keyboard Removal

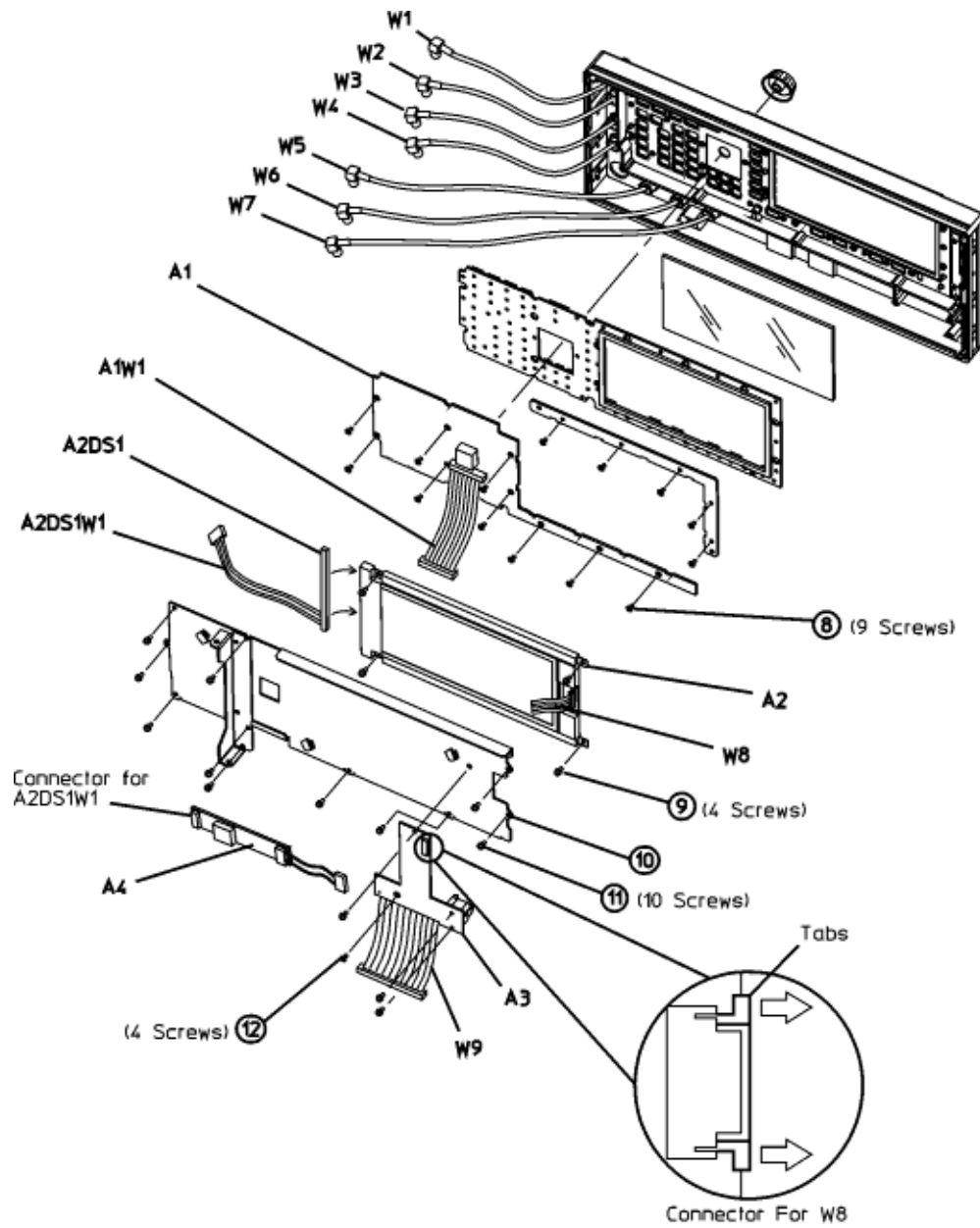

se97a

## A2 Display

### Tools Required

- T-10 driver

### Removal Procedure

Refer to Figure 2-5 for this procedure.

1. Disconnect the power cord.
2. Remove the front panel. Refer to ["Front Panel" on page 2-8](#).
3. Disconnect the A2DS1W1 cable from the A4 Inverter.
4. Disconnect the W8 ribbon cable from the A3 Power Switch by lifting the white tabs on the connector.
5. Using the T-10 driver, remove the four screws (12) from the A3 Power Switch.
6. Remove the A3 Power Switch.
7. Using the T-10 driver, remove the ten screws (11) that secure the RFI shielding (10) to the front panel.
8. Remove the metal shielding.
9. Using the T-10 driver, remove the four screws (9) that secure the A2 Display to the front panel.
10. Remove the A2 Display.

### Replacement Procedure

- Reverse the order of the removal procedure.
- Torque all T-10 screws to 9 in-lbs.
- Perform the post-repair adjustments and performance tests that pertain to this removal procedure.

Figure 2-5 A2 Display Removal

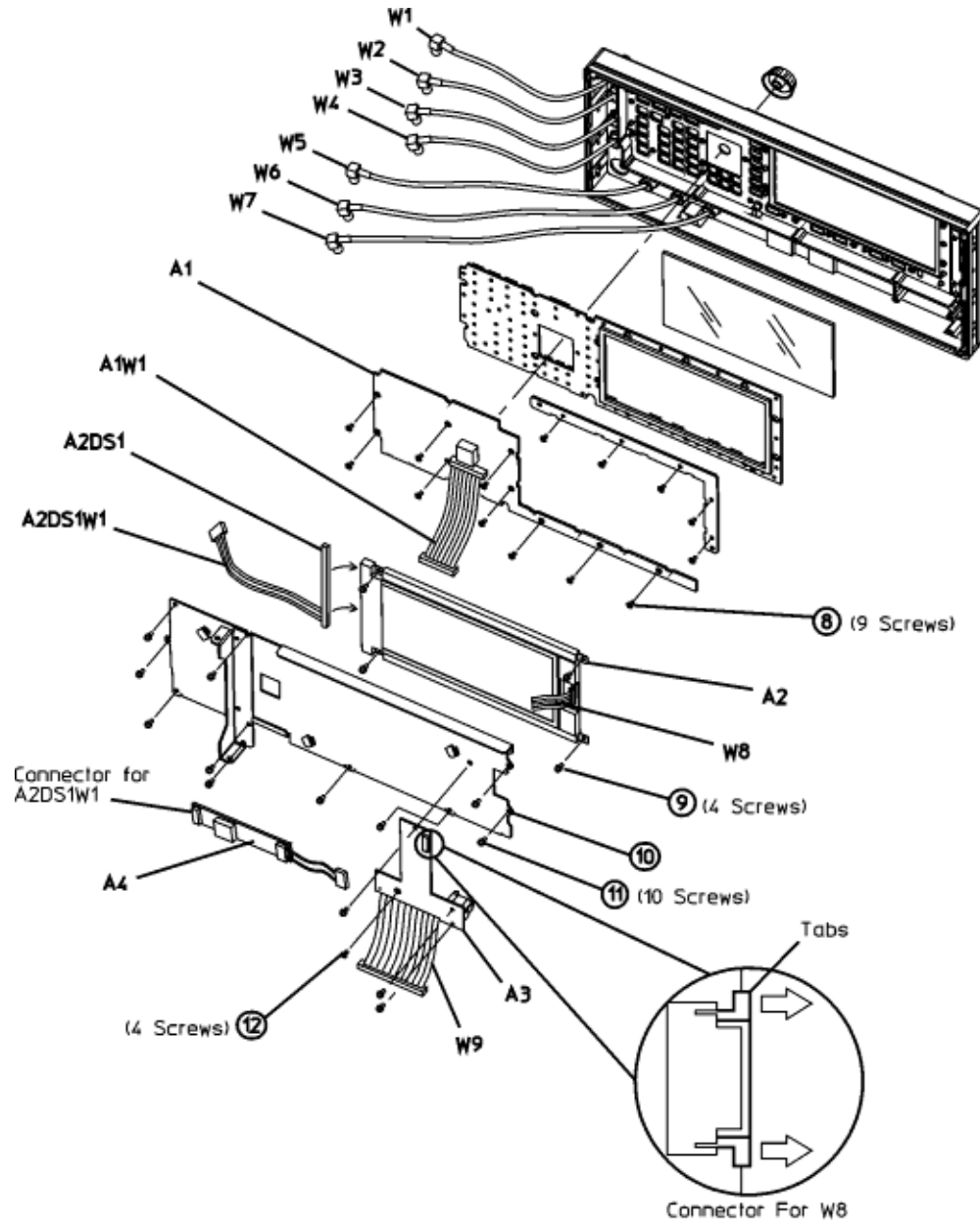

se97a

## A2DS1 Display Backlight

### Tools Required

- T-10 driver
- small phillips screw driver

### Removal Procedure

Refer to Figure 2-6.

1. Disconnect the power cord.
2. Remove the front panel. Refer to "[Front Panel](#)" on page 2-8.
3. Disconnect the A2DSW1 cable from the A4 Inverter.
4. Disconnect the W8 ribbon cable from the A3 Power Switch by lifting the white tabs on the connector.
5. Using the T-10 driver, remove the four screws (12) from the A3 Power Switch.
6. Remove the A3 Power Switch.
7. Using the T-10 driver, remove the ten screws (11) that secure the RFI shielding (10) to the front panel.
8. Remove the metal shielding.
9. Using the T-10 driver, remove the four screws (9) that secure the A2 Display to the front panel.
10. Remove the A2 Display.
11. Using a small phillips screw driver, remove the screw (1) that secures the cover (2) over the A2DS1 Display Backlight.
12. Remove the A2DS1 Display Backlight.

### Replacement Procedure

---

**NOTE** When replacing the A2DS1 Display Backlight make sure the reflective paper is behind the light.

---

- Reverse the order of the removal procedure.
- Torque all T-10 screws to 9 in-lbs.
- Perform the post-repair adjustments and performance tests that pertain to this removal procedure.



Figure 2-6 A2DS1 Display Backlight Removal

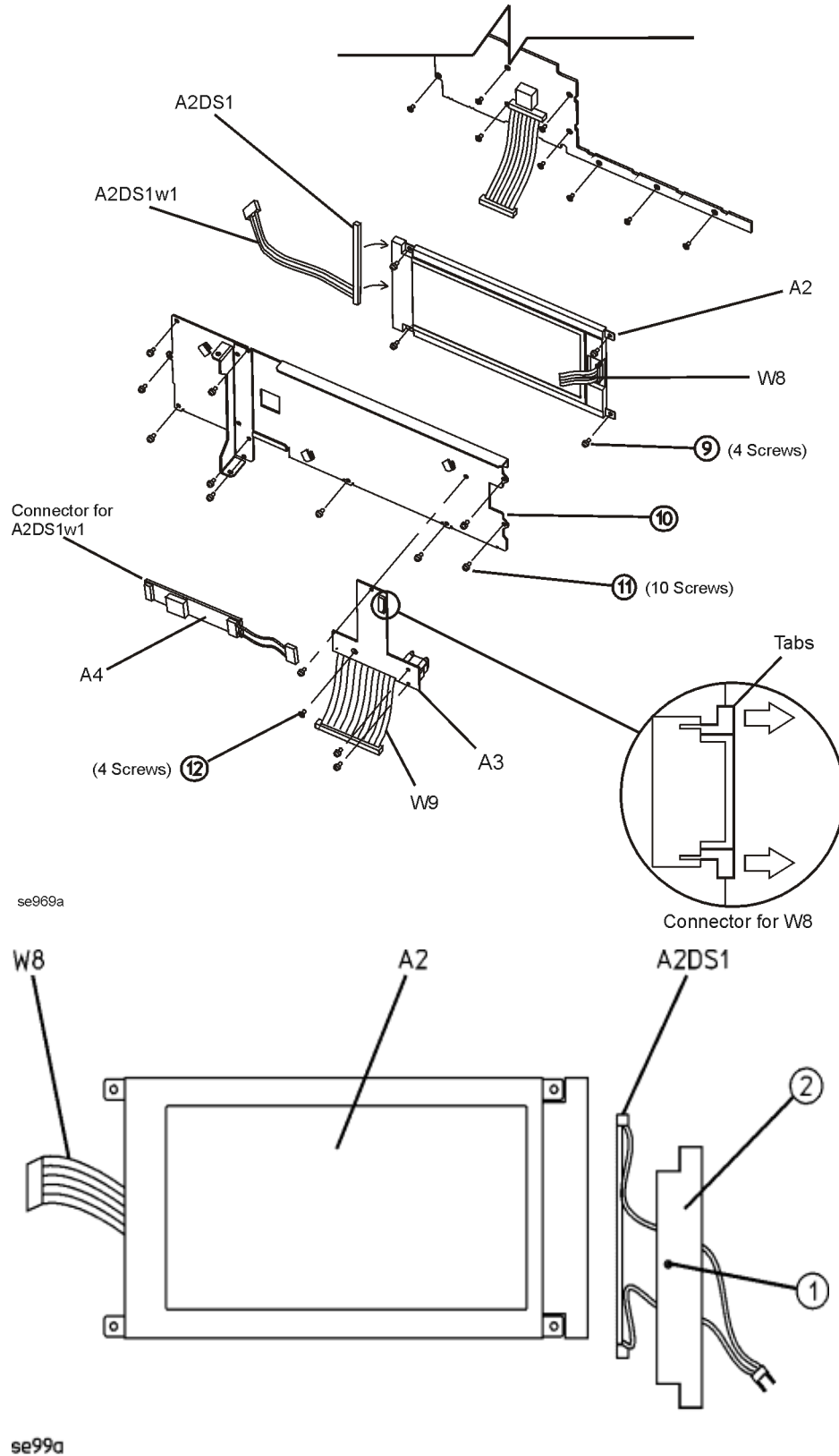

## A3 Power Switch

### Tools Required

- T-10 driver

### Removal Procedure

Refer to Figure 2-7 for this procedure.

1. Disconnect the power cord.
2. Remove the front panel. Refer to "[Front Panel](#)" on page 2-8.
3. Disconnect the W8 ribbon cable from the A3 Power Switch by lifting the white tabs on the connector.
4. Using the T-10 driver, remove the four screws (12) from the A3 Power Switch.
5. Remove the A3 Power Switch.

### Replacement Procedure

- Reverse the order of the removal procedure.
- Torque all T-10 screws to 9 in-lbs.
- Perform the post-repair adjustments and performance tests that pertain to this removal procedure.

Figure 2-7 A3 Power Switch Removal

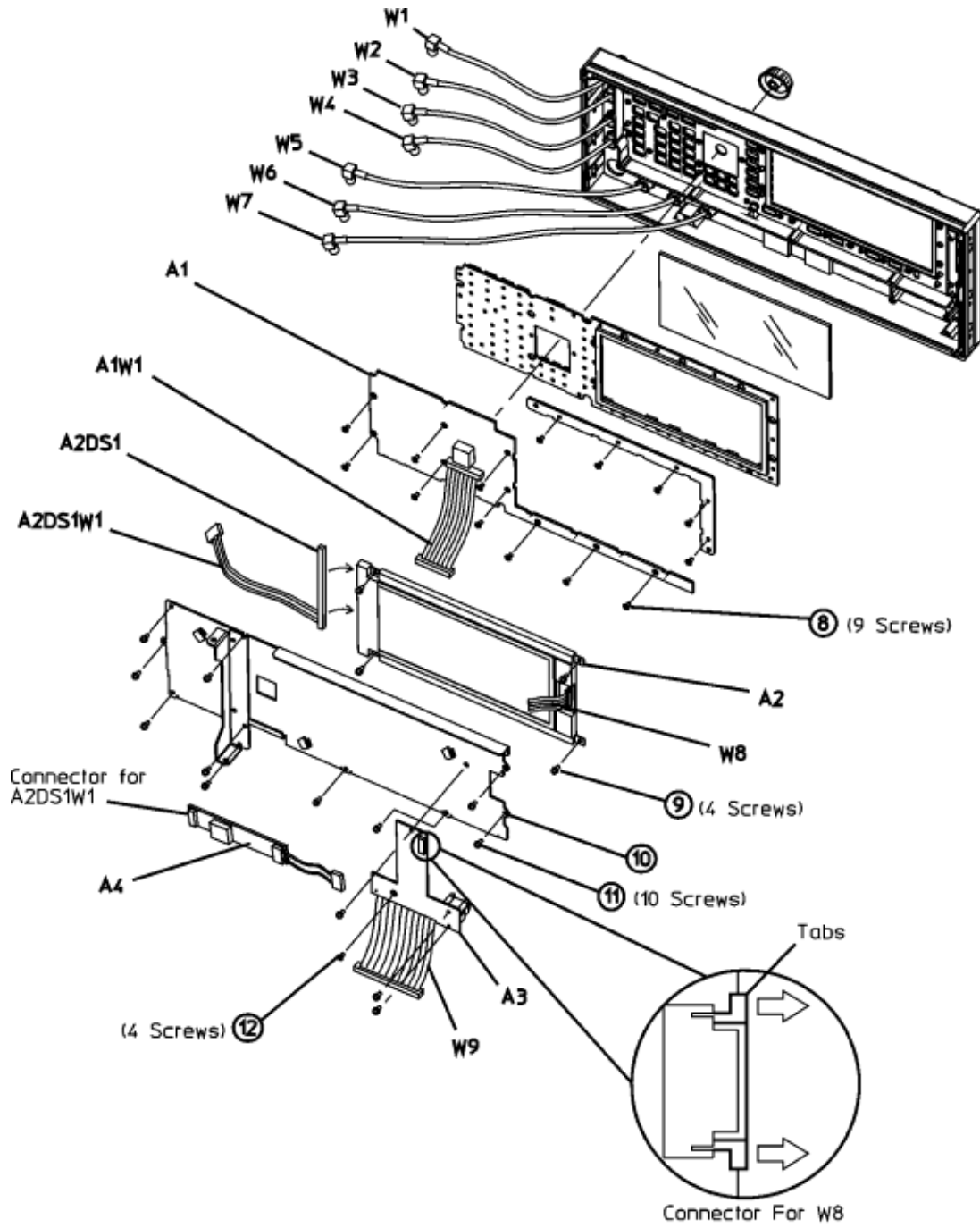

se97a

## A4 Inverter

### Tools Required

- none

### Removal Procedure

Refer to Figure 2-8 for this procedure.

1. Disconnect the power cord.
2. Remove the front panel. Refer to ["Front Panel" on page 2-8](#).
3. Disconnect the A4W1 cable from the A31 Motherboard P12.
4. Disconnect the A2DSW1 cable from the A4 Inverter.

---

**CAUTION** The A4 Inverter is fragile and can be damaged when pulled away from the velcro attachment.

---

5. Remove the A4 Inverter by pulling it away from the front panel.

### Replacement Procedure

- Reverse the order of the removal procedure.
- Perform the post-repair adjustments and performance tests that pertain to this removal procedure.

Figure 2-8 A4 Inverter Removal

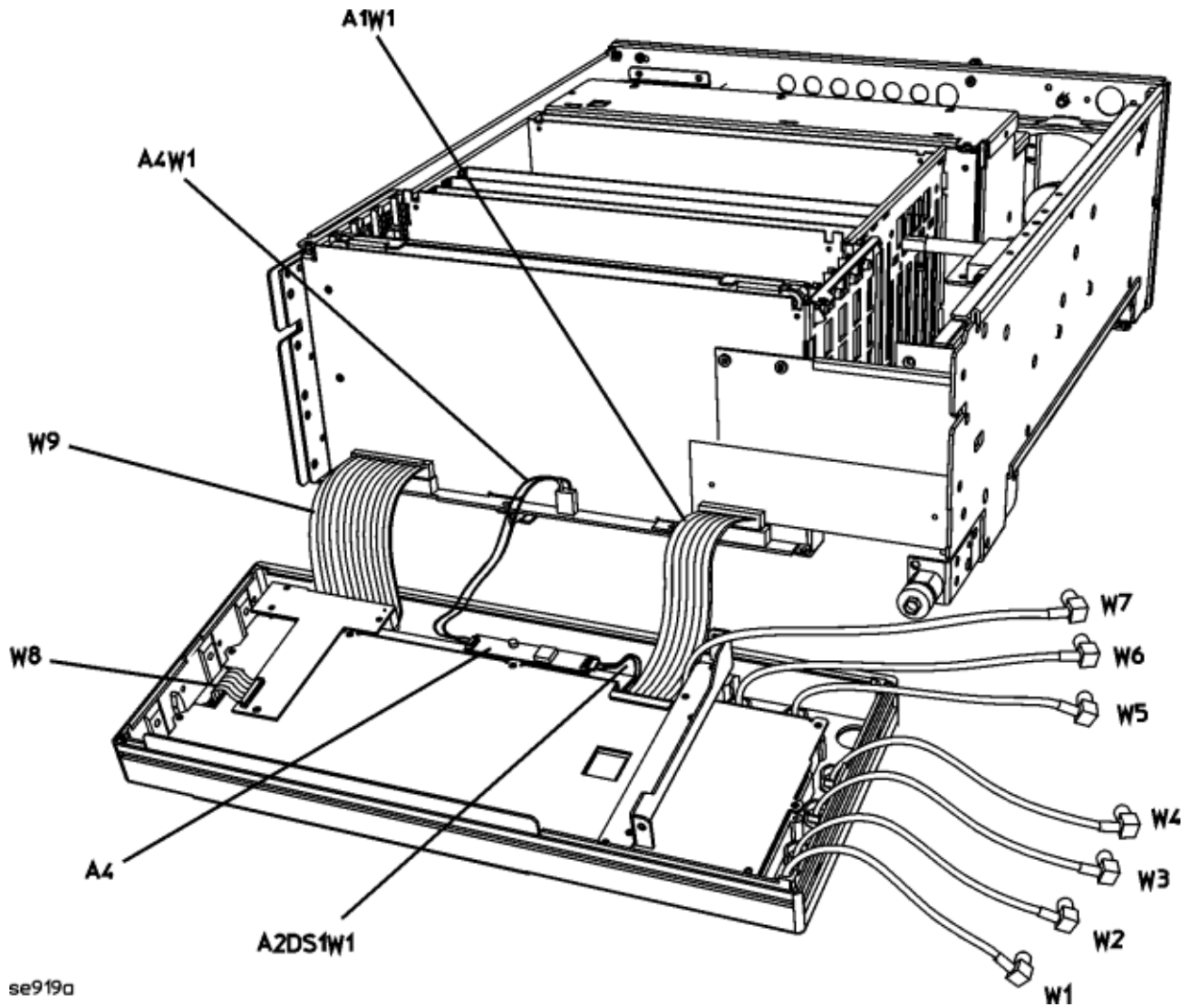

se919a

## A5 Sampler

### Tools Required

- none

### Removal Procedure

Refer to Figure 2-9 for this procedure.

1. Disconnect the power cord.
2. Remove the covers from the signal generator. Refer to ["Outer Instrument Cover" on page 2-4](#) and ["Inner Instrument Cover" on page 2-6](#).
3. Position the signal generator with the front panel facing you.
4. Lift the retention levers and disconnect the A5 Sampler from the A31 Motherboard.
5. Lift the A5 Sampler out of the slot.

### Replacement Procedure

- Reverse the order of the removal procedure.
- Perform the post-repair adjustments and performance tests that pertain to this removal procedure.

Figure 2-9 A5 Sampler

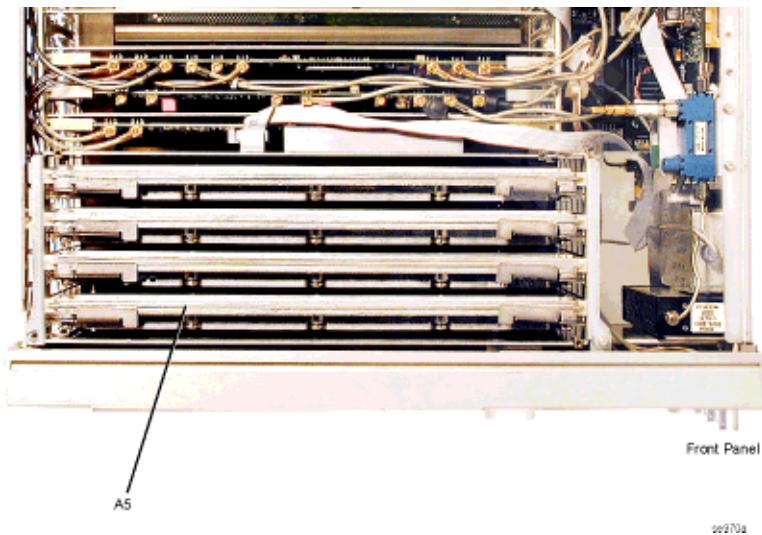

00970a

## A6 Frac-N

### Tools Required

- none

### Removal Procedure

Refer to Figure 2-10 for this procedure.

1. Disconnect the power cord.
2. Remove the covers from the signal generator. Refer to ["Outer Instrument Cover" on page 2-4](#) and ["Inner Instrument Cover" on page 2-6](#).
3. Position the signal generator with the front panel facing you.
4. Lift the retention levers and disconnect the A6 Frac-N from the A31 Motherboard.
5. Lift the A6 Frac-N out of the slot.

### Replacement Procedure

- Reverse the order of the removal procedure.
- Perform the post-repair adjustments and performance tests that pertain to this removal procedure.



Figure 2-10 A6 Frac-N

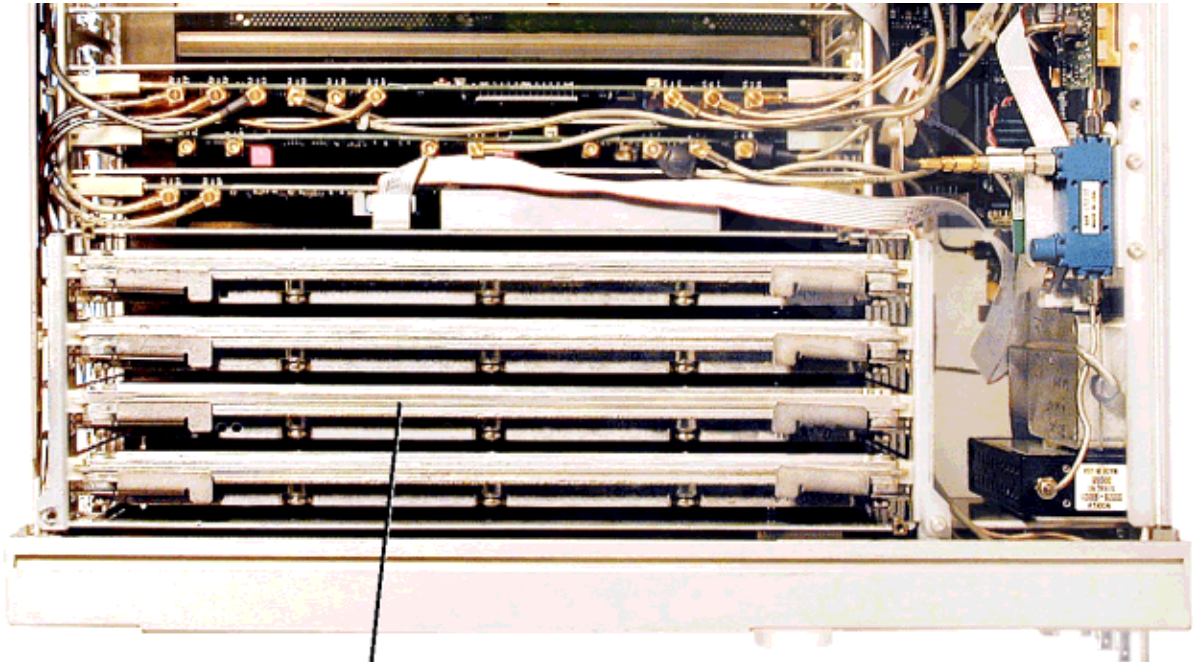

Front Panel

A6

se971a

## A7 Reference (Standard and Option UNJ)

### Tools Required

- none

### Removal Procedure

Refer to Figure 2-11 for this procedure.

1. Disconnect the power cord.
2. Remove the covers from the signal generator. Refer to ["Outer Instrument Cover" on page 2-4](#) and ["Inner Instrument Cover" on page 2-6](#).
3. Position the signal generator with the front panel facing you.
4. Lift the retention levers and disconnect the A7 Reference from the A31 Motherboard.
5. Lift the A7 Reference out of the slot.

### Replacement Procedure

- Reverse the order of the removal procedure.
- Perform the post-repair adjustments and performance tests that pertain to this removal procedure.

Figure 2-11 A7 Reference

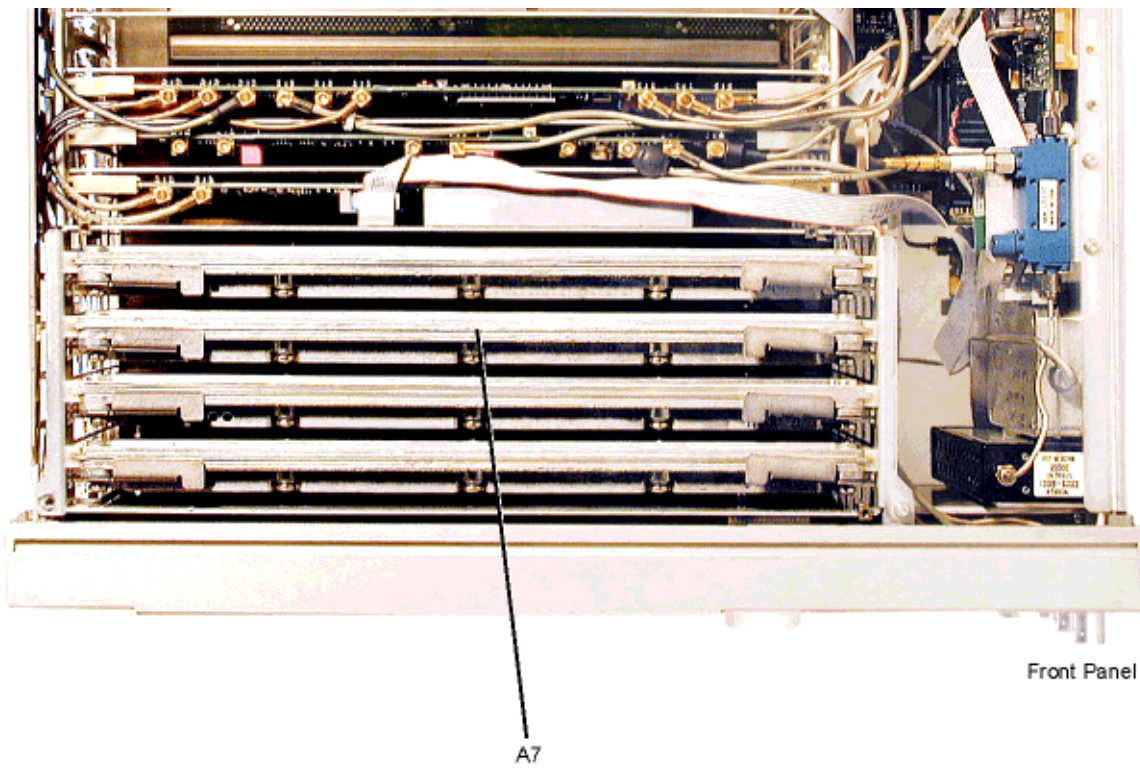

se972a

## A8 Output

### Tools Required

- none

### Removal Procedure

Refer to Figure 2-12 for this procedure.

1. Disconnect the power cord.
2. Remove the covers from the signal generator. Refer to ["Outer Instrument Cover" on page 2-4](#) and ["Inner Instrument Cover" on page 2-6](#).
3. Position the signal generator with the front panel facing you.
4. Lift the retention levers and disconnect the A8 Output from the A31 Motherboard.
5. Lift the A8 Output out of the slot.

### Replacement Procedure

- Reverse the order of the removal procedure.
- Perform the post-repair adjustments and performance tests that pertain to this removal procedure.

Figure 2-12      A8 Output

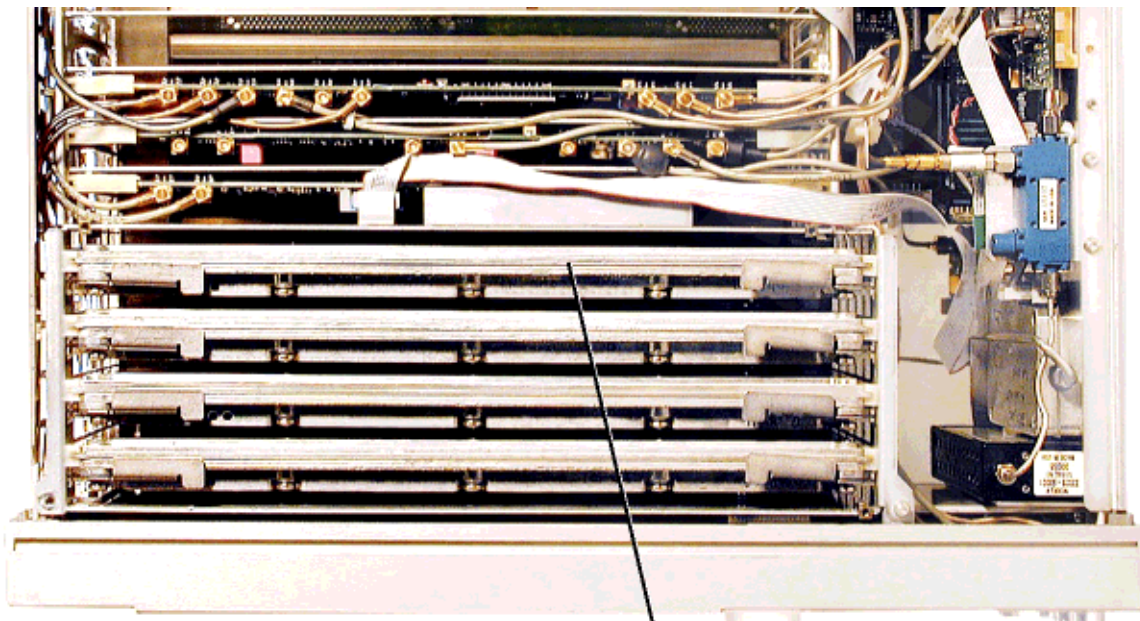

Front Panel

A8

se073a

## A9 YIG Driver

### Tools Required

- needle-nose pliers

### Removal Procedure

Refer to Figure 2-13 for this procedure.

1. Disconnect the power cord.
2. Remove the covers from the signal generator. Refer to ["Outer Instrument Cover" on page 2-4](#) and ["Inner Instrument Cover" on page 2-6](#).
3. Position the signal generator with the front panel facing you.
4. Using the needle-nose pliers, disconnect the W10 flexible cable from the A9J3.
5. Using the needle-nose pliers, disconnect the W11 A9J4 flexible cable from the A9J4.
6. Disconnect the W12 ribbon cable from the A9J5.
7. Lift the retention levers and disconnect the A9 YIG Driver from the A31 Motherboard.
8. Lift the A9 YIG Driver out of the slot.

### Replacement Procedure

- Reverse the order of the removal procedure.
- Perform the post-repair adjustments and performance tests that pertain to this removal procedure.

Figure 2-13 A9 YIG Driver

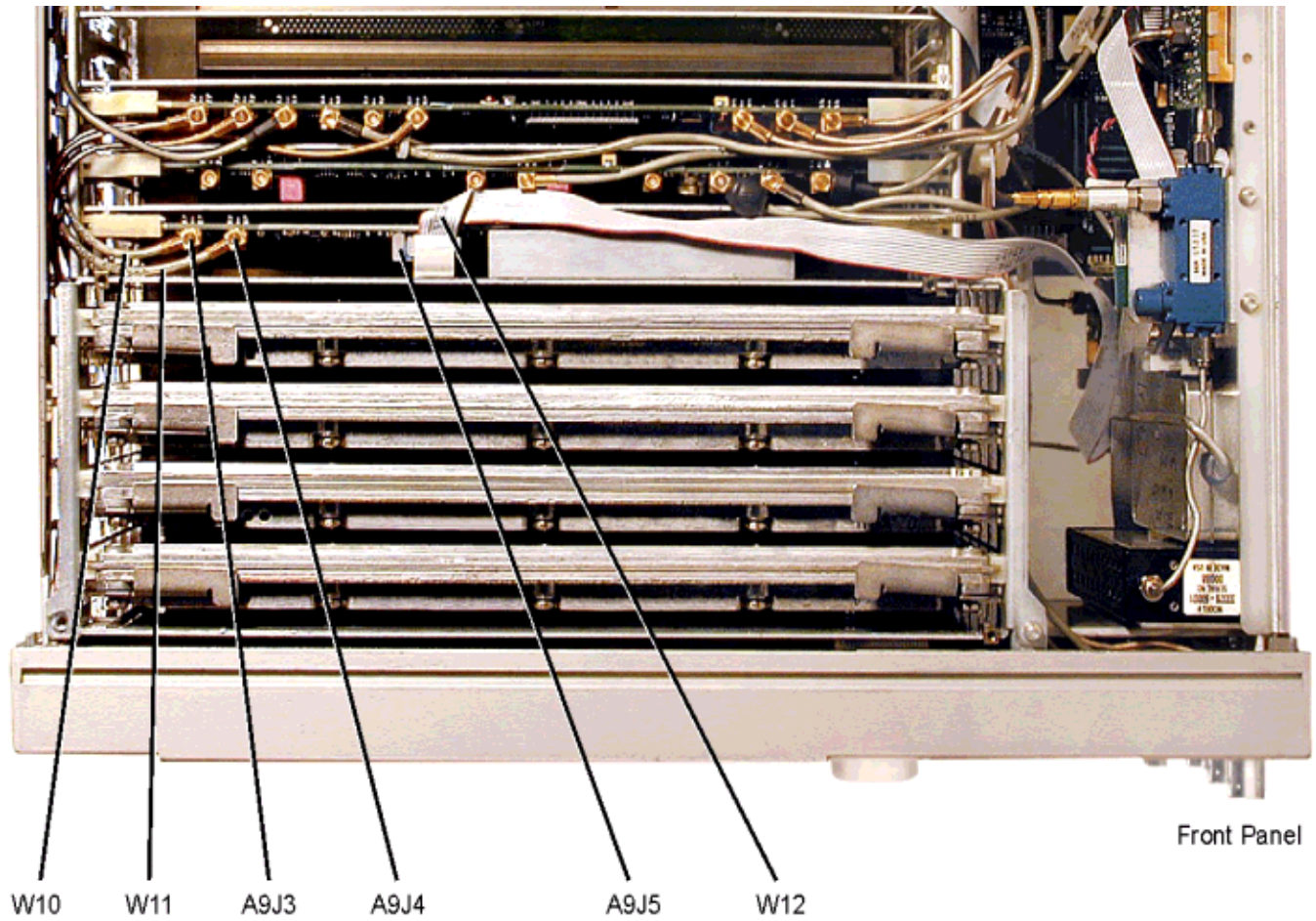

se926a

## A10 ALC

### Tools Required

- needle-nose pliers

### Removal Procedure

Refer to Figure 2-14 for this procedure.

1. Disconnect the power cord.
2. Remove the covers from the signal generator. Refer to ["Outer Instrument Cover" on page 2-4](#) and ["Inner Instrument Cover" on page 2-6](#).
3. Position the signal generator with the front panel facing you.
4. Using the needle-nose pliers, disconnect the W4 flexible cable from A10J4.
5. Using the needle-nose pliers, disconnect the W13 flexible cable from A10J201.
6. Using the needle-nose pliers, disconnect the W14 flexible cable from A10J5.
7. Using the needle-nose pliers, disconnect the W15 flexible cable from A10J3.
8. Lift the retention levers and disconnect the A10 ALC from the A31 Motherboard.
9. Lift the A10 ALC out of the slot.

### Replacement Procedure

- Reverse the order of the removal procedure.
- Perform the post-repair adjustments and performance tests that pertain to this removal procedure.



Figure 2-14 A10 ALC

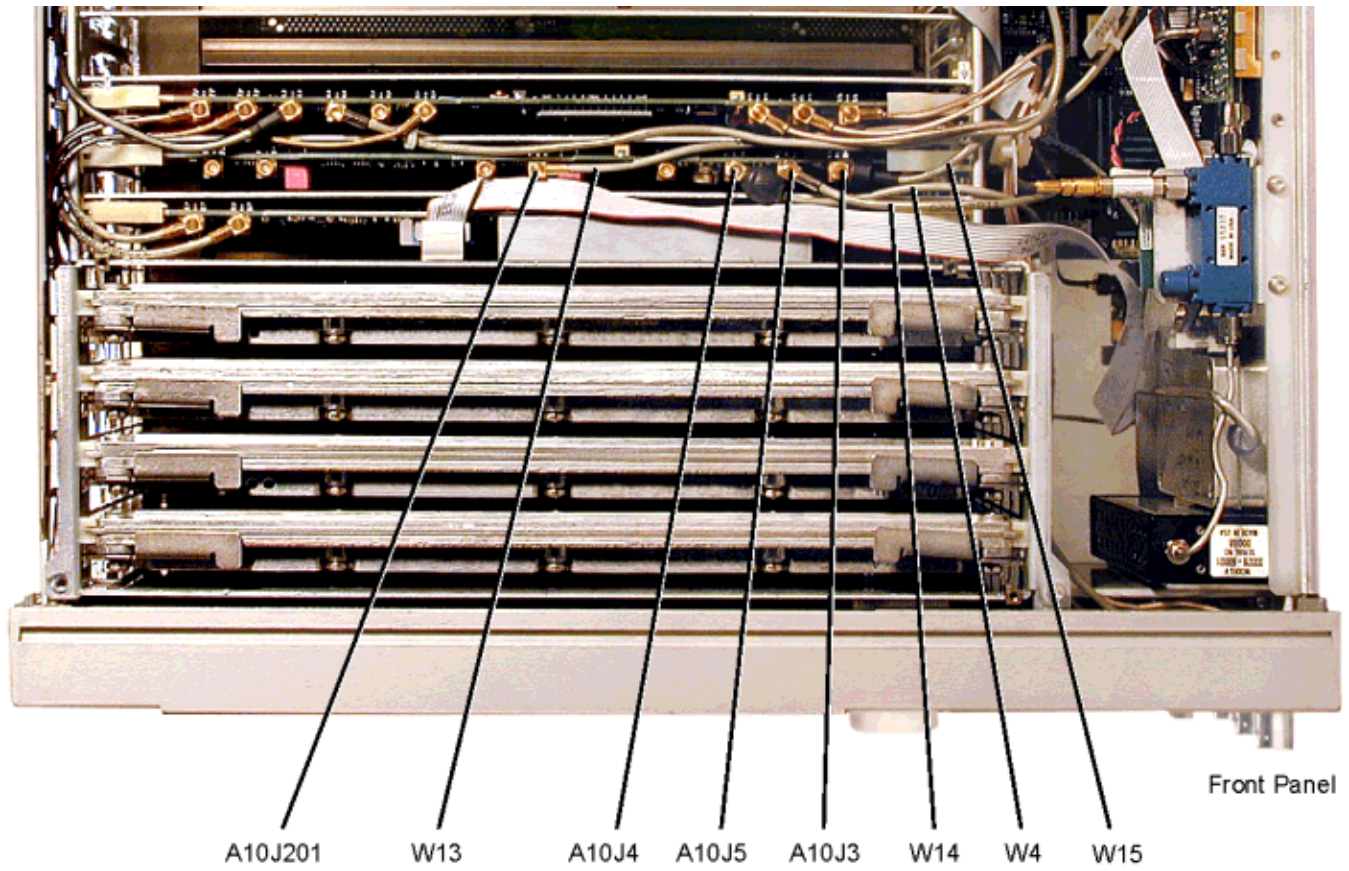

se927a

## A11 Pulse/Analog Modulation Generator

### Tools Required

- needle-nose pliers

### Removal Procedure

Refer to Figure 2-15 for this procedure.

1. Disconnect the power cord.
2. Remove the covers from the signal generator. Refer to ["Outer Instrument Cover" on page 2-4](#) and ["Inner Instrument Cover" on page 2-6](#).
3. Position the signal generator with the front panel facing you.
4. Using the needle-nose pliers, disconnect the W1 flexible cable from A11J401.
5. Using the needle-nose pliers, disconnect the W2 flexible cable from A11J402.
6. Using the needle-nose pliers, disconnect the W3 flexible cable from A11J403.
7. Using the needle-nose pliers, disconnect the W5 flexible cable from A11J201.
8. Using the needle-nose pliers, disconnect the W6 flexible cable from A11J203.
9. Using the needle-nose pliers, disconnect the W7 flexible cable from A11J202.
10. Using the needle-nose pliers, disconnect the W16 flexible cable from A11J204.
11. Using the needle-nose pliers, disconnect the W17 flexible cable from A11J205.
12. Lift the retention levers and disconnect the A11 Pulse/Analog Modulation Generator from the A31 Motherboard.
13. Lift the A11 Pulse/Analog Modulation Generator out of the slot.

### Replacement Procedure

- Reverse the order of the removal procedure.
- Perform the post-repair adjustments and performance tests that pertain to this removal procedure.

Figure 2-15 A11 Pulse/Analog Modulation Generator

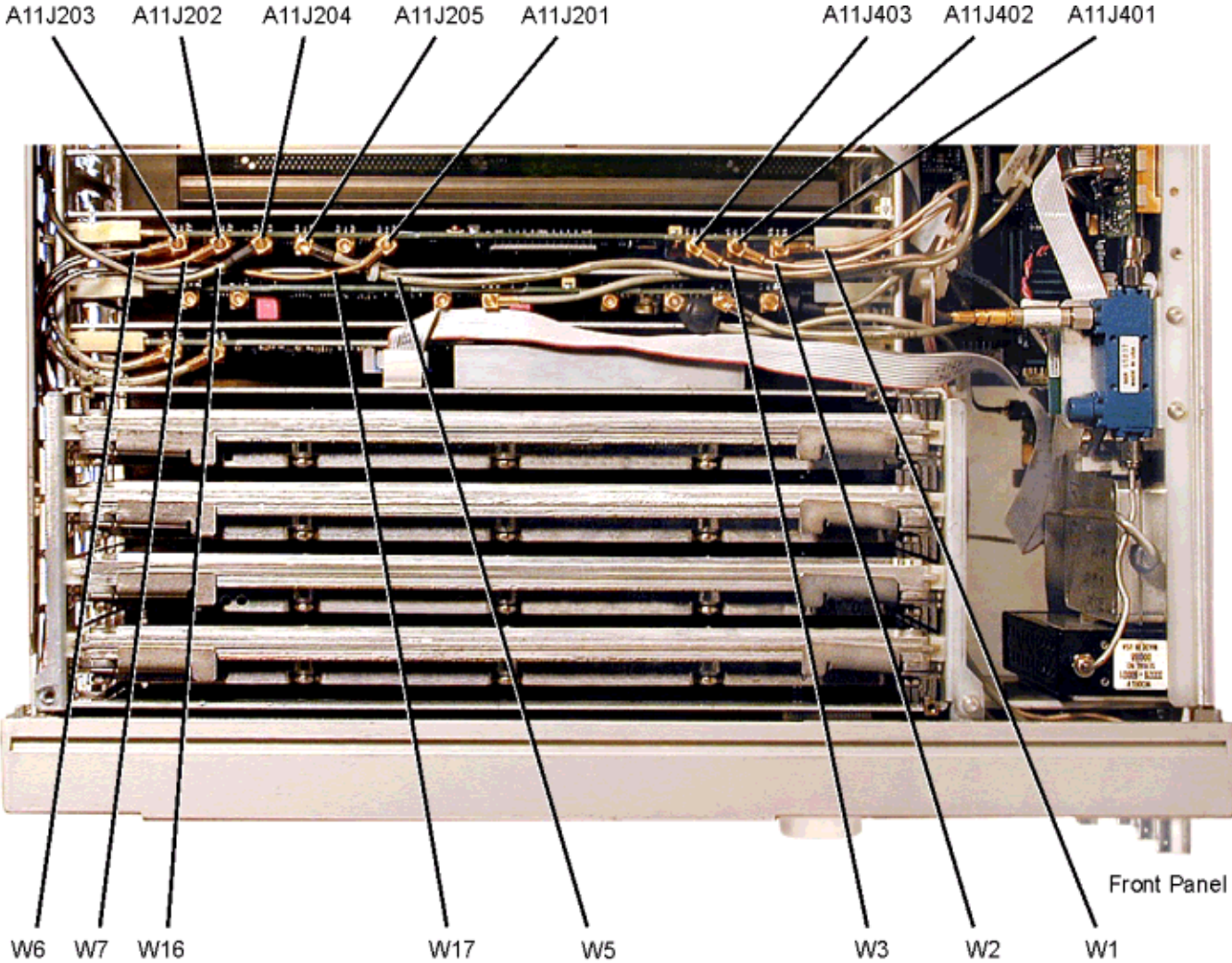

se928a

## A18 CPU

### Tools Required

- none

### Removal Procedure

Refer to Figure 2-16 for this procedure.

1. Disconnect the power cord.
2. Remove the covers from the signal generator. Refer to ["Outer Instrument Cover" on page 2-4](#) and ["Inner Instrument Cover" on page 2-6](#).
3. Position the signal generator with the front panel facing you.
4. Disconnect the W18 ribbon cable from A18J1.
5. Disconnect the W19 ribbon cable from A18J2.
6. Lift the retention levers and disconnect the A18 CPU from the A31 Motherboard.
7. Lift the A18 CPU out of the slot.

### Replacement Procedure

- Reverse the order of the removal procedure.
- Perform the post-repair adjustments and performance tests that pertain to this removal procedure.

Figure 2-16 A18 CPU

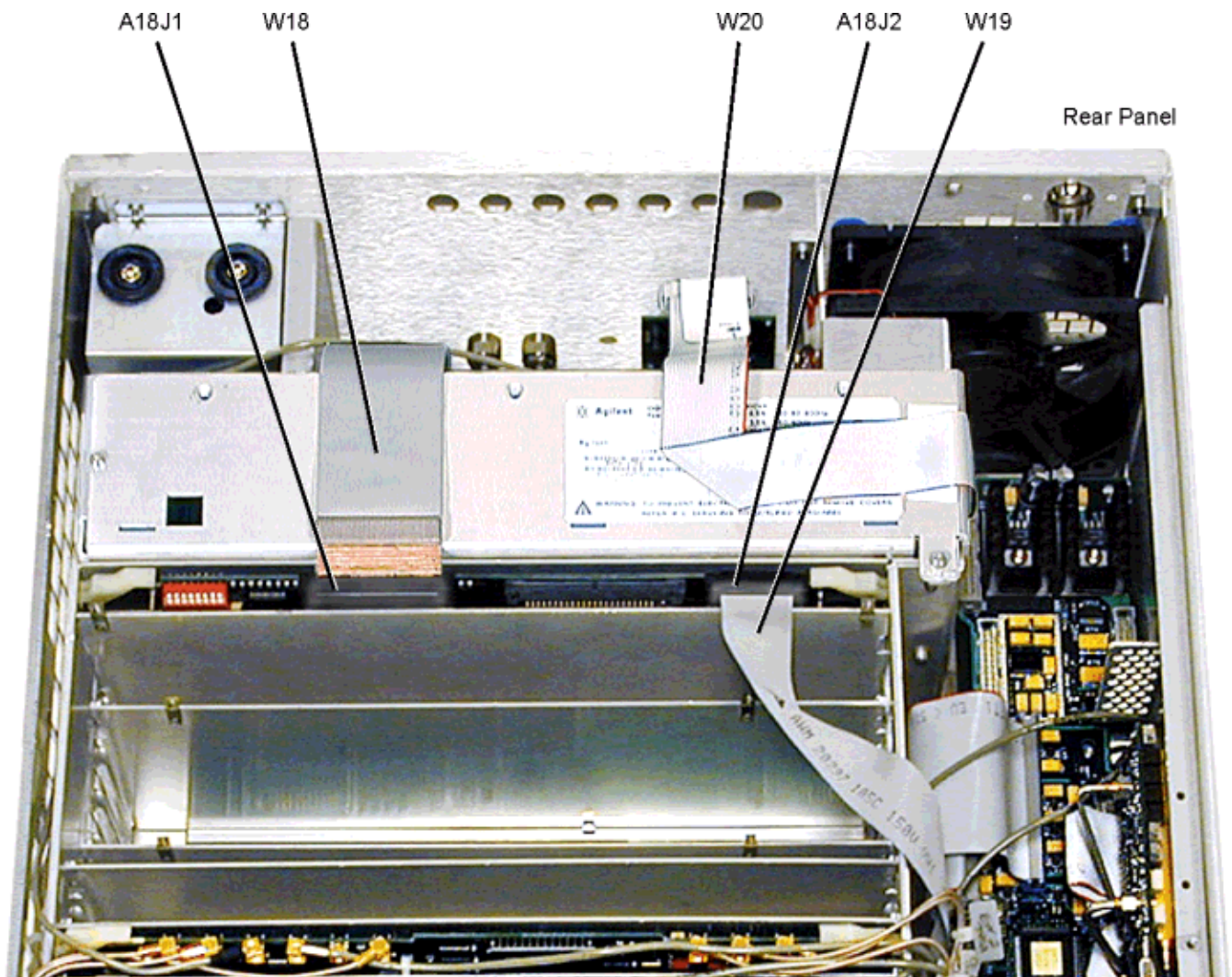

se929a

## A18BT1

---

**WARNING** This battery contains lithium. Do not incinerate or puncture this battery. Do not install this battery backwards. To dispose of the battery in a safe manner, refer to [Chapter 5, "Lithium Battery Disposal,"](#) on page 5-4.

---

### Tools Required

- flat head screw driver

### Removal Procedure

Refer to Figure 2-16 for this procedure.

1. Disconnect the power cord.
2. Remove the covers from the signal generator. Refer to ["Outer Instrument Cover"](#) on page 2-4 and ["Inner Instrument Cover"](#) on page 2-6.
3. Position the signal generator with the front panel facing you.
4. Disconnect the W18 ribbon cable A18J1.
5. Disconnect the W19 ribbon cable from A18J2.
6. Lift the retention levers and disconnect the A18 CPU from the A31 Motherboard.
7. Lift the A18 CPU out of the slot.
8. Using the flat head screw driver, remove the A18BT1 by leveraging the battery out of the battery's socket.

### Replacement Procedure

- To install the battery, the positive side is aligned with the positive sign on the A18's battery clip.
- Reverse the remaining steps of the removal procedure.
- Perform the post-repair adjustments and performance tests that pertain to this removal procedure.

Figure 2-17

A18BT1

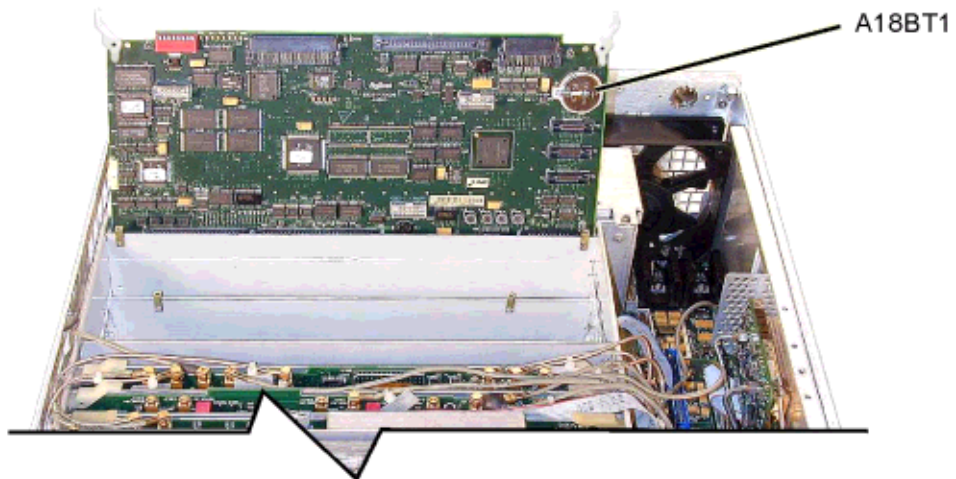
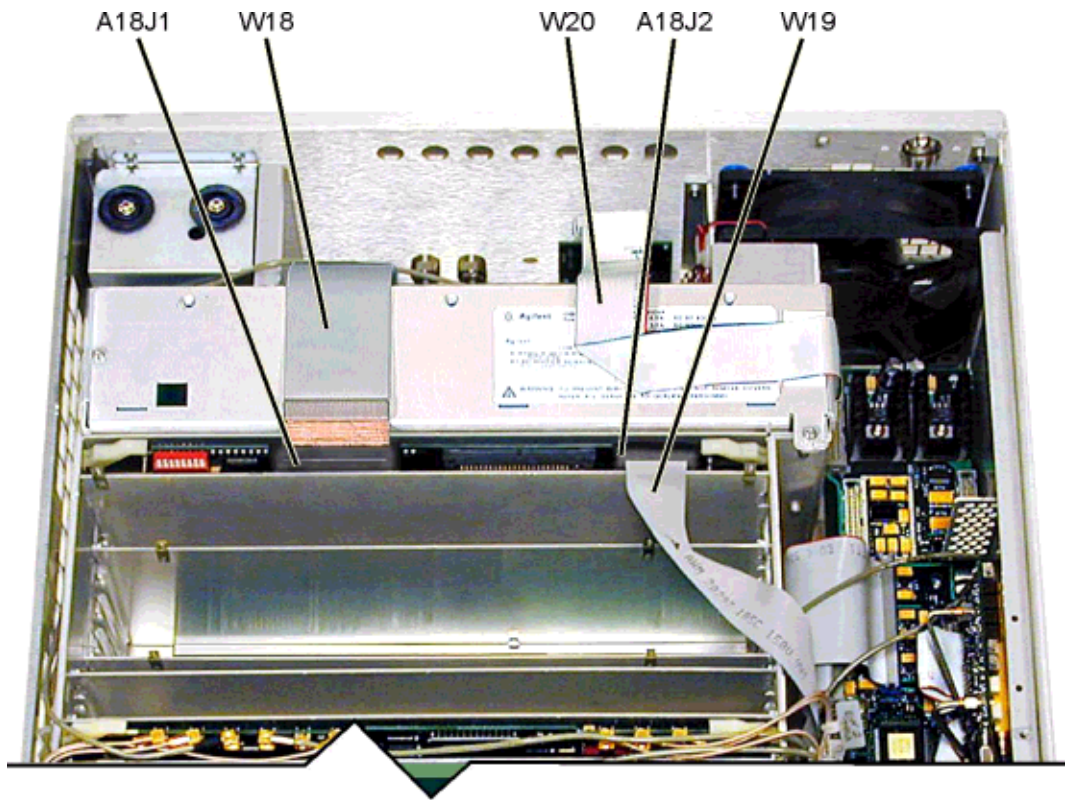

se992a

## A19 Power Supply

### Tools Required

- T-10 driver
- needle-nose pliers

### Removal Procedure

Refer to Figure 2-18 for this procedure.

1. Disconnect the power cord.
2. Remove the covers from the signal generator. Refer to "[Outer Instrument Cover](#)" on page 2-4 and "[Inner Instrument Cover](#)" on page 2-6.
3. Position the signal generator with the A31 Motherboard facing you.
4. Using the needle-nose pliers, disconnect the W16 flexible cable (refer to [Figure 2-15 on page 2-33](#)) from the A11 Pulse/Analog Modulation Generator J204.
5. Disconnect the W20 ribbon cable from the A20 SMI.
6. Using the T-10 driver, remove the two screws (1) that secure the A19 Power Supply to the struts located on the bottom.
7. Using the T-10 driver, remove the two additional screws (2) that are attached to the bottom frame.
8. Position the signal generator with the A31 Motherboard flat on the work surface and the rear panel facing you.
9. Remove the W18 ribbon cable from the A18 CPU J1.
10. Using the T-10 driver, remove the two screws (3) that secure the A19 Power Supply to the struts located on the top and an additional screw (4) located on the top frame.
11. If you have Option UNJ refer to "[A32 10 MHz Crystal Oscillator \(Option UNJ\)](#)" on page 2-72. You must remove this assembly before continuing to the next step.
12. Using the needle-nose pliers, disconnect A22W1 from the power supply.
13. Pull the power supply out of the chassis while guiding the A22 Line Module cable through the opening of the power supply.
14. Remove the power supply from the signal generator's chassis.

### Replacement Procedure

- Reverse the order of the removal procedure.
- Torque all T-10 screws to 9 in-lbs.
- Perform the post-repair adjustments and performance tests that pertain to this removal procedure.



Figure 2-18 A19 Power Supply Removal

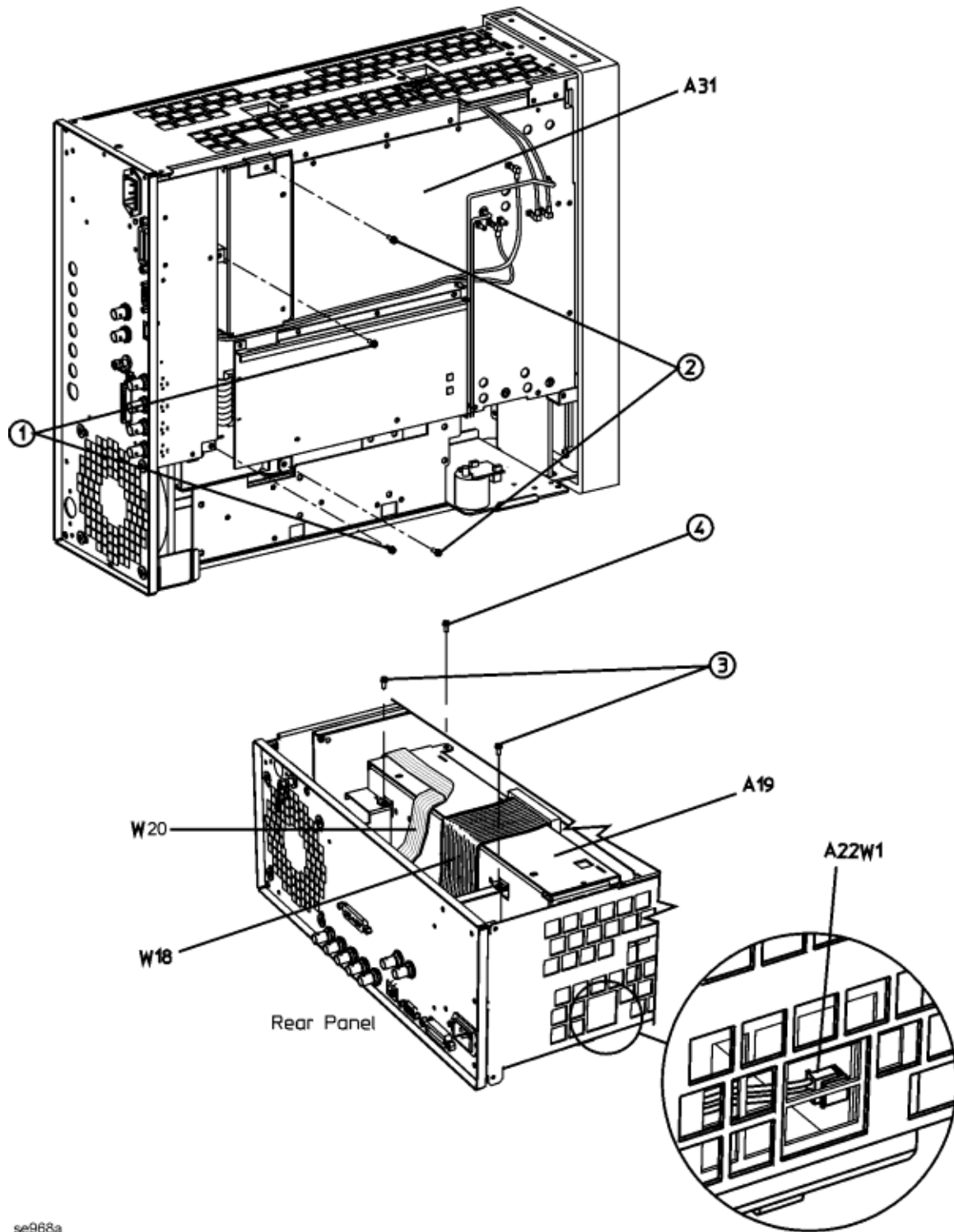

se968a

## Rear Panel

### Tools Required

- T-10 driver
- needle-nose pliers

### Removal Procedure

Refer to Figure 2-19 for this procedure.

1. Disconnect the power cord.
2. Remove the covers from the signal generator. Refer to ["Outer Instrument Cover" on page 2-4](#) and ["Inner Instrument Cover" on page 2-6](#).
3. Position the signal generator with the A31 Motherboard panel facing you.
4. Using the needle-nose pliers, disconnect the W16 flexible cable (refer to [Figure 2-15 on page 2-33](#)) from the A11 Pulse/Analog Modulation Generator J204.
5. Disconnect the W20 ribbon cable from the A20 SMI.
6. Disconnect the W22 flexible cable (10 MHz input) from the A31 Motherboard J1042.
7. Disconnect the W21 flexible cable (10 MHz output) from the A31 Motherboard J1043.
8. Using the T-10 driver, remove the two screws (1) that secure the A21 Rear-Panel Interface to the A19 Power Supply.
9. Disconnect the W18 ribbon cable that connects A21 Rear-Panel Interface J3 to the A18 CPU J1.
10. Disconnect the W23 ribbon cable that connects A21 Rear-Panel Interface J2 to A31 Motherboard P241.
11. Using the T-10 driver, remove the four screws (3) that attach the rear panel to the frame.
12. Using the T-10 driver, remove the two screws (4) that secure the A19 Power Supply to the top rear panel's left and right struts.
13. Using the needle-nose pliers, disconnect the A22W1 cable from the A19 Power Supply.
14. If you have Option UNJ, disconnect the W47 flexible cable from A32J1 using the needle-nose pliers. Refer to figure ["A32 10 MHz Crystal Oscillator \(Option UNJ\)" on page 2-72](#).
15. Pull the rear panel away from the signal generator's chassis while guiding the A22W1 through the opening of the power supply.

### Replacement Procedure

- Reverse the order of the removal procedure.
- Torque all T-10 screws to 9 in-lbs.
- Perform the post-repair adjustments and performance tests that pertain to this removal procedure.

Figure 2-19 Rear Panel Removal

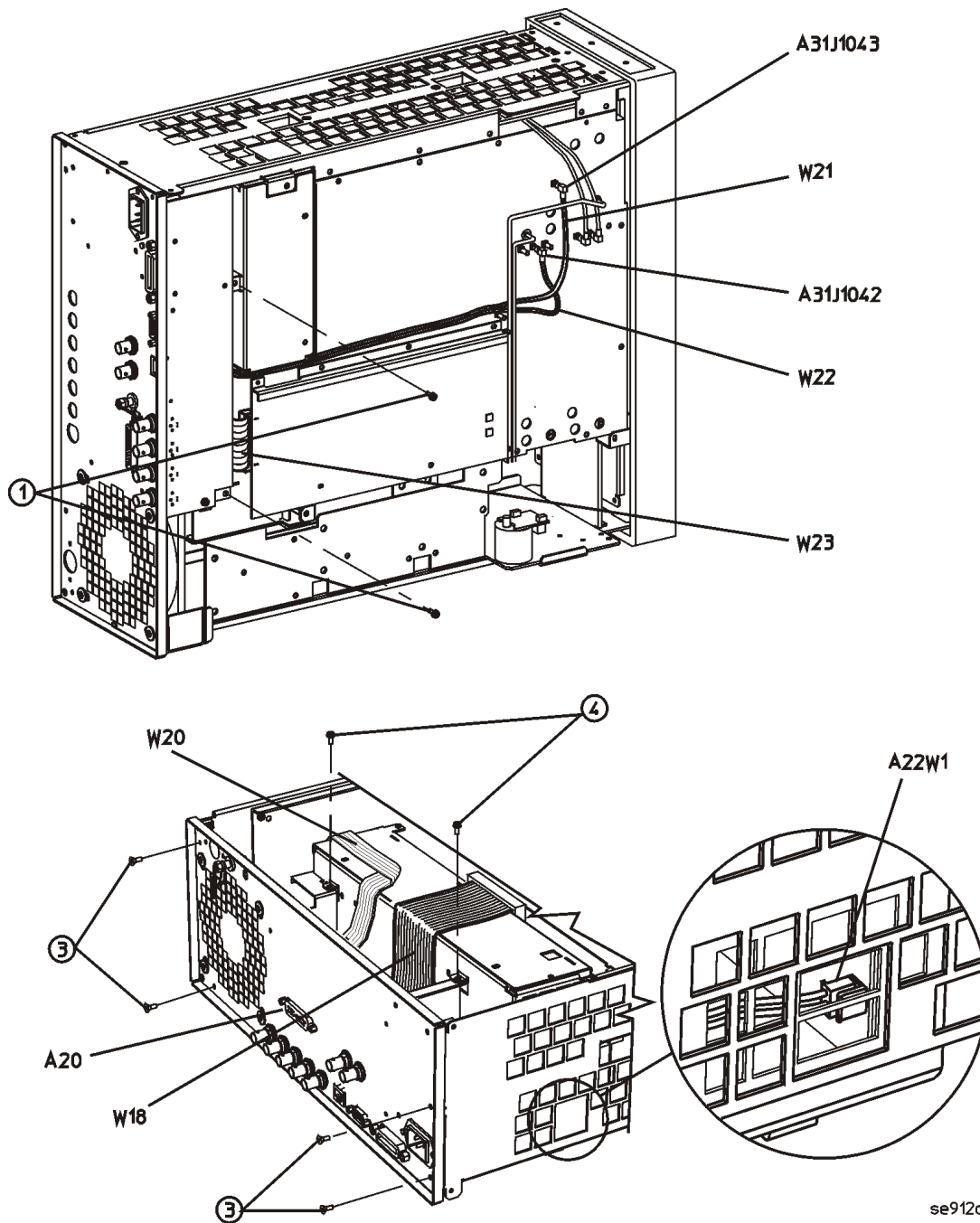

se912a

## A20 SMI (Source Module Interface)

### Tools Required

- 5.0 mm hex-nut driver
- needle-nose pliers

### Removal Procedure

Refer to Figure 2-20 for this procedure.

1. Disconnect the power cord.
2. Remove the covers from the signal generator. Refer to ["Outer Instrument Cover" on page 2-4](#) and ["Inner Instrument Cover" on page 2-6](#).
3. Using the needle-nose pliers, disconnect the W16 flexible cable from the A11 Pulse/Analog Modulation Generator J204.
4. Disconnect the W20 ribbon cable from the A26 MID J20.
5. Using the 5.0 mm driver, remove the hex screws (1) and washers that secure the A20 SMI to the rear panel.
6. Remove the A20 SMI.

### Replacement Procedure

- Reverse the order of the removal procedure.
- Torque all hex screws to 9 in-lbs.
- Perform the post-repair adjustments and performance tests that pertain to this removal procedure.

Figure 2-20 A20 SMI

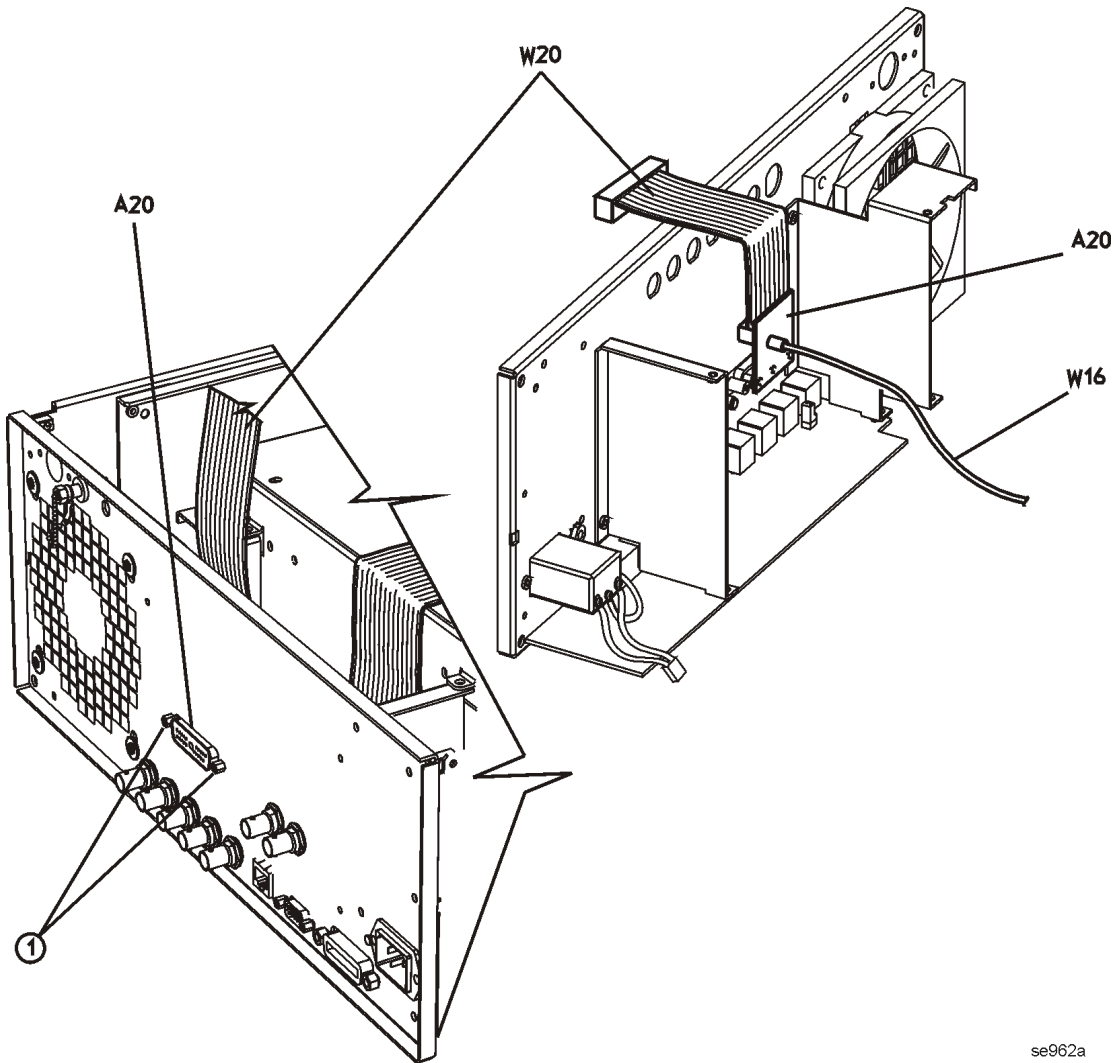

se962a

## A21 Rear-Panel Interface

### Tools Required

- T-10 driver
- 9/16" hex-nut driver
- 5.0 mm hex-nut driver
- 7.0 mm hex-nut driver
- needle-nose pliers

### Removal Procedure

Refer to Figure 2-21 for this procedure.

1. Disconnect the power cord.
2. Remove the covers from the signal generator. Refer to ["Outer Instrument Cover" on page 2-4](#) and ["Inner Instrument Cover" on page 2-6](#).
3. Remove the rear panel. Refer to ["Rear Panel" on page 2-40](#).
4. Using the 9/16" hex-nut driver, remove the nuts and washers securing the four BNC connectors (1) at the base of the rear panel.
5. Using the 5.0 mm hex-nut driver, remove the screws (2) from the RS-232 port.
6. Using the 7.0 mm hex-nut driver, remove the screws (3) from the GPIB port.
7. Using the T-10 driver, remove the two screws (4) from the bottom of the A21 Rear-Panel Interface.
8. Disconnect the B1 Fan cable (6) from A21P6.

### Replacement Procedure

- Reverse the order of the removal procedure.
- Torque all T-10 screws to 9 in-lbs.
- Torque all hex-nuts to 9 in-lbs.
- Torque all BNC nuts to 21 in-lbs.
- Perform the post-repair adjustments and performance tests that pertain to this removal procedure.

Figure 2-21 A21 Rear-Panel Interface

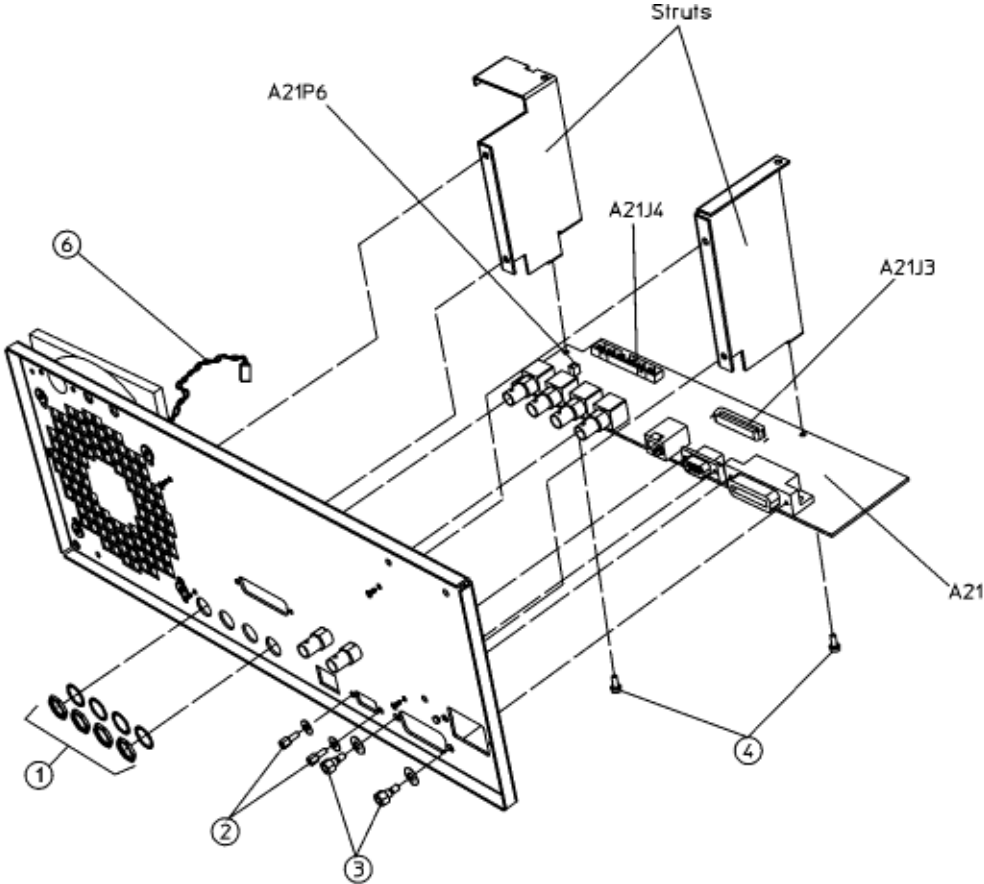

se913a

## A22 Line Module

### Tools Required

- T-10 driver
- 5.0 mm wrench
- needle-nose pliers

### Removal Procedure

Refer to Figure 2-22 for this procedure.

1. Disconnect the power cord.
2. Remove the covers from the signal generator. Refer to ["Outer Instrument Cover" on page 2-4](#) and ["Inner Instrument Cover" on page 2-6](#).
3. Position the signal generator with the rear panel facing you.
4. If you have Option UNJ, refer to ["A32 10 MHz Crystal Oscillator \(Option UNJ\)" on page 2-72](#) to remove the assembly.
5. Using the T-10 driver, remove the two screws (1) that attach the A22 Line Module to the rear panel.
6. Using the 5.0 mm wrench, remove the nut (2) and washer from the grounding screw to disconnect A22W2.
7. Using the needle-nose pliers, disconnect the A22W1 from the A19 Power Supply through the side panel of the signal generator.
8. While pulling out the A22 Line Module from the rear panel, guide out the A22W1 from the A19's shielding.
9. Remove the A22 Line Module

### Replacement Procedure

- Reverse the order of the removal procedure.
- Torque all T-10 screws to 9 in-lbs.
- Torque all nuts to 9 in-lbs.
- Perform the post-repair adjustments and performance tests that pertain to this removal procedure.



Figure 2-22 A22 Line Module Removal

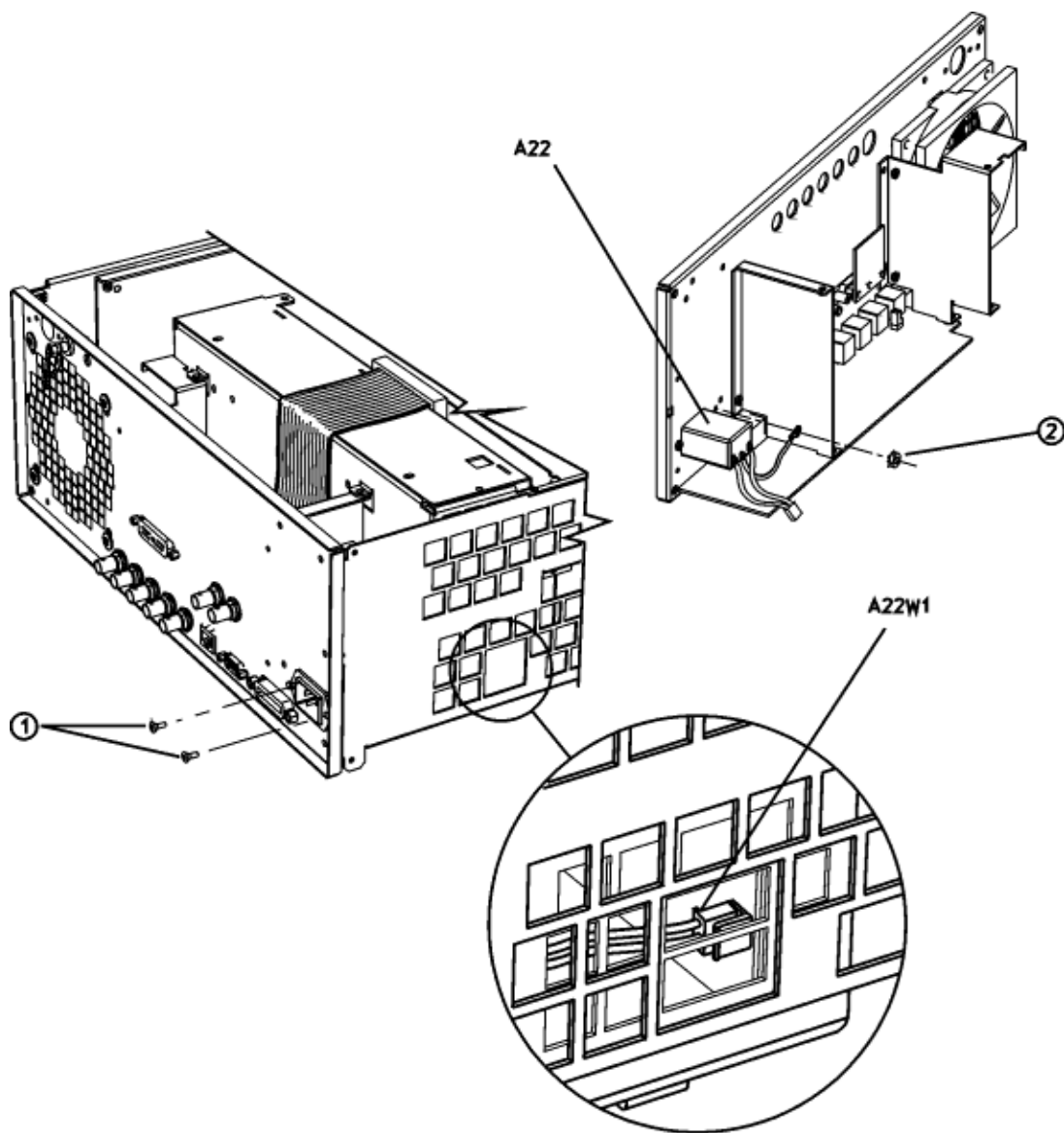

se963a

## AT1 115 dB Attenuator (Option 1E1)

### Tools Required

- T-10 driver
- 5/16" open ended wrench

### Removal Procedure

Refer to Figure 2-23 for this procedure.

1. Disconnect the power cord.
2. Remove the covers from the signal generator. Refer to ["Outer Instrument Cover" on page 2-4](#) and ["Inner Instrument Cover" on page 2-6](#).
3. Position the signal generator with the A31 Motherboard facing you so that the RF deck is on top.
4. Disconnect the AT1W1 ribbon cable from A26J13.
5. Using the 5/16" open ended wrench, disconnect the W24 and W25 RF cables from the AT1 115 dB Attenuator.
6. Using the T-10 driver, remove the two screws (1) that attach the AT1 115 dB Attenuator to the side panel.
7. Remove the attenuator from the A26 MID bracket.
8. Using the T-10 driver, remove the sheet metal from the attenuator.

### Replacement Procedure

- Reverse the order of the removal procedure.
- Torque all T-10 screws to 9 in-lbs.
- Torque all RF connectors to 8 in-lbs.
- Perform the post-repair adjustments and performance tests that pertain to this removal procedure.

Figure 2-23 AT1 115 dB Attenuator (Option 1E1)

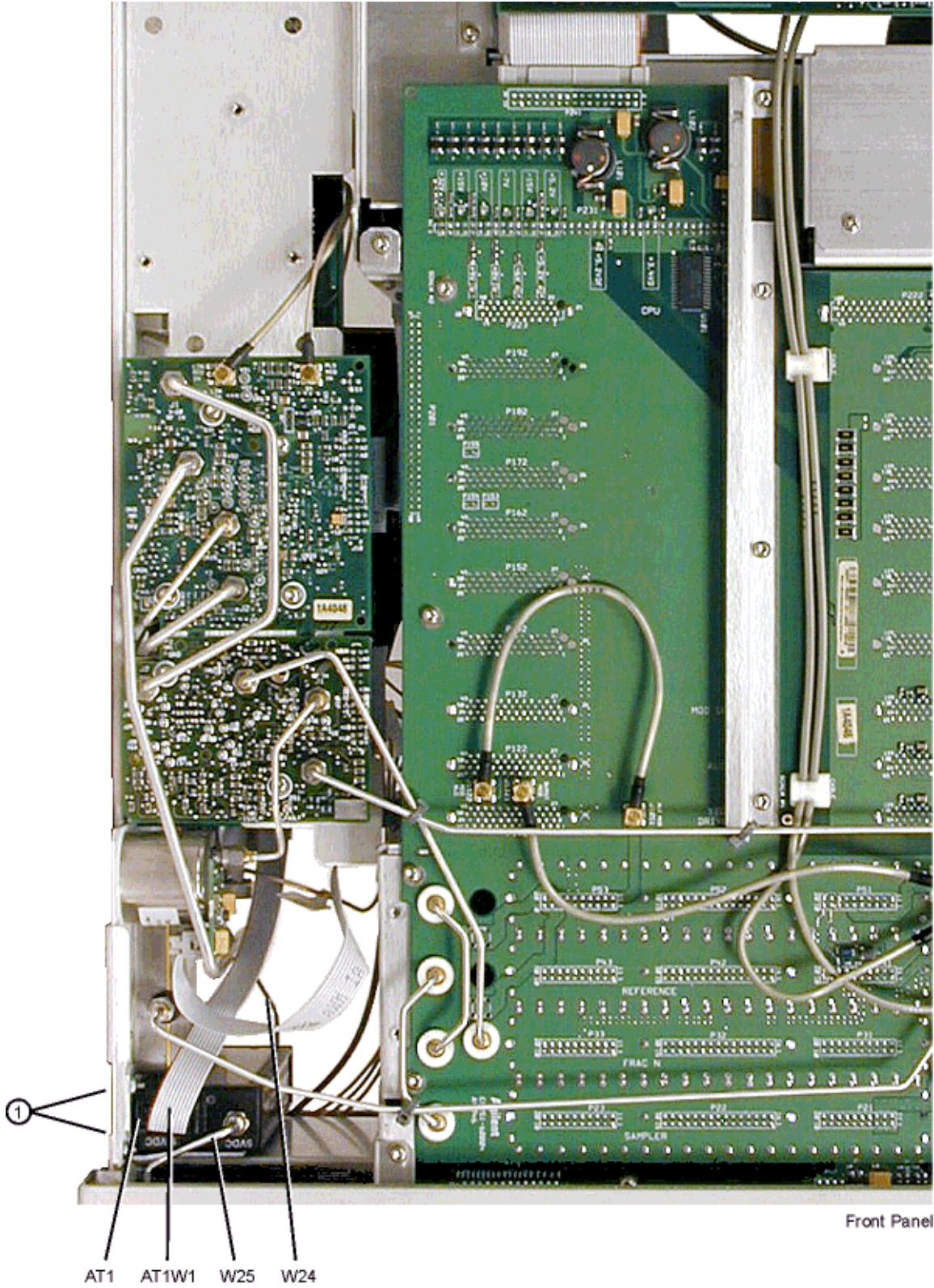

se960a

## A23 Low Band Coupler/Detector

### Tools Required

- T-10 driver
- 5/16" open ended wrench
- wire cutters

### Removal Procedure

Refer to Figure 2-24 for this procedure.

1. Disconnect the power cord.
2. Remove the covers from the signal generator. Refer to ["Outer Instrument Cover" on page 2-4](#) and ["Inner Instrument Cover" on page 2-6](#).
3. Position the signal generator so that the A31 Motherboard is facing you and the RF deck is on top.
4. Using the 5/16" open ended wrench, disconnect the W27 RF cable from the A23 Low Band Coupler/Detector.
5. Using the wire cutters, cut the tie wrap that secures the W27 RF cable to the A23 Low Band Coupler/Detector.
6. Using the 5/16" open ended wrench, disconnect the W37 RF cable from the A23 Low Band Coupler/Detector.
7. Using the T-10 driver, remove the two screws that attach the A23 Low Band Coupler/Detector to the side panel.
8. Disconnect the W33 ribbon cable from the A23 Low Band Coupler/Detector.
9. Disconnect the W14 flexible cable from the A23 Low Band Coupler/Detector.
10. Remove the A23 Low Band Coupler/Detector.

### Replacement Procedure

- Reverse the order of the removal procedure.
- Torque all T-10 screws to 9 in-lbs.
- Torque all RF connectors to 8 in-lbs.
- Perform the post-repair adjustments and performance tests that pertain to this removal procedure.

Figure 2-24 A23 Low Band Coupler/Detector

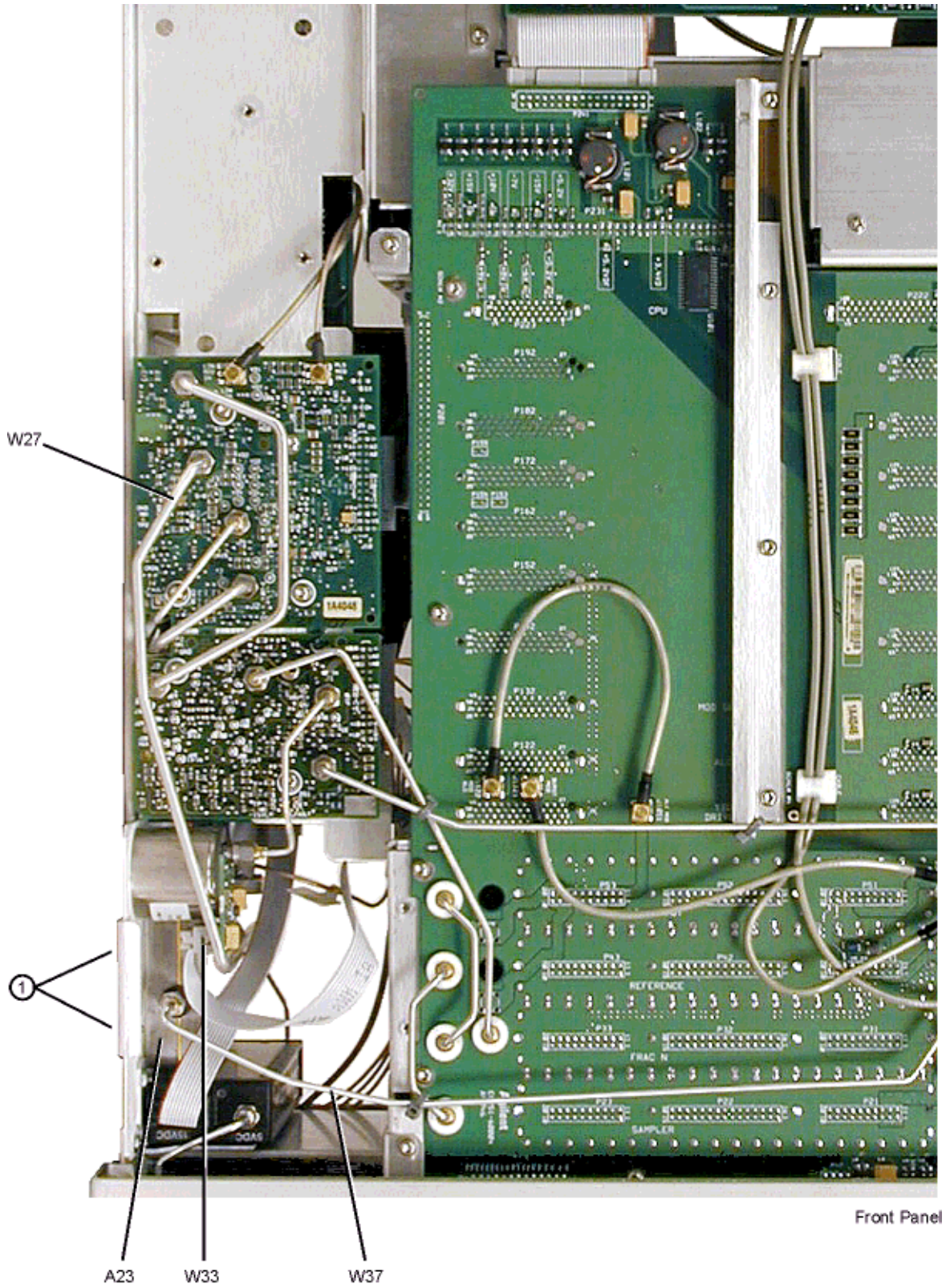

se958a

## **A24 20 GHz High Band Coupler (E8241A and E8251A Models Only)**

### **Tools Required**

- T-10 driver
- 5/16" open ended wrench

### **Removal Procedure**

Refer to Figure 2-25 for this procedure.

1. Disconnect the power cord.
2. Remove the covers from the signal generator. Refer to ["Outer Instrument Cover" on page 2-4](#) and ["Inner Instrument Cover" on page 2-6](#).
3. Position the signal generator with the A31 Motherboard facing away from you and the RF deck on top.
4. Using the 5/16" open ended wrench, disconnect the A24 High Band Detector from the A24 20 GHz High Band Coupler.
5. Using the 5/16" open ended wrench, disconnect the W30 and W24 RF cables from the A24 20 GHz High Band Coupler's input and output.
6. Disconnect the A25BW1 bias board power cable from the A26 MID J12.
7. Using the T-10 driver, remove the two screws (refer to [Figure 2-24 on page 2-51](#), item 1) that attach the coupler to the side panel.
8. Remove the A24 20 GHz High Band Coupler.

### **Replacement Procedure**

- Reverse the order of the removal procedure.
- Torque all T-10 screws to 9 in-lbs.
- Torque all RF connectors to 8 in-lbs.
- Perform the post-repair adjustments and performance tests that pertain to this removal procedure.

Figure 2-25

A24 20 GHz High Band Coupler

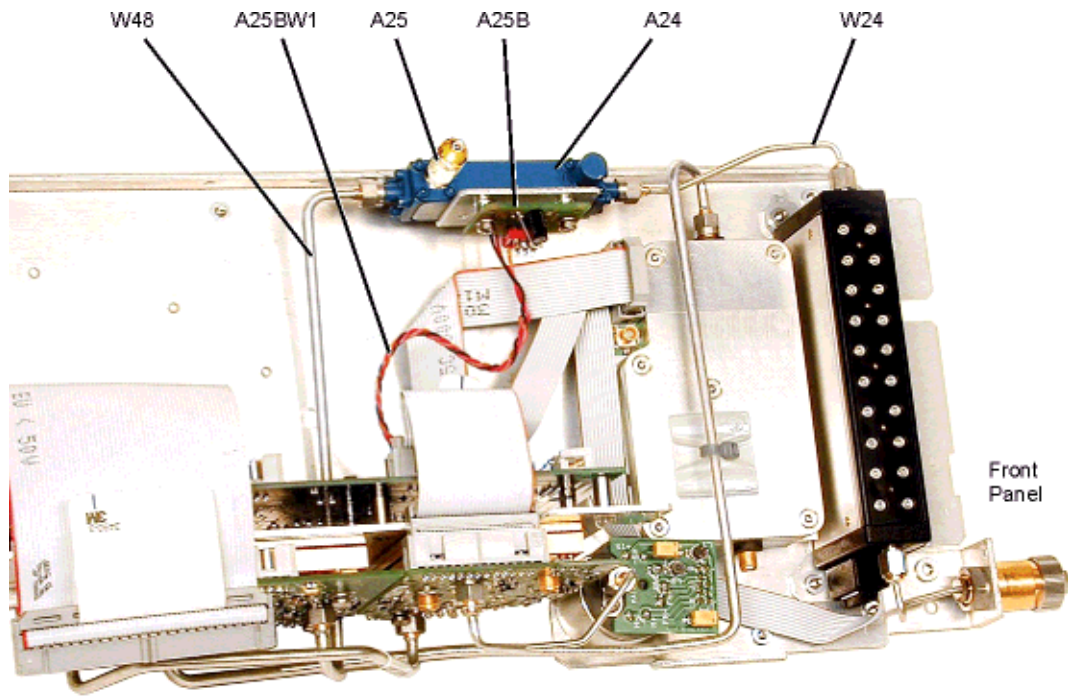

se974a

## A24 40 GHz High Band Coupler (E8244A and E8254A Models Only)

### Tools Required

- T-10 driver
- 5/16" open ended wrench

### Removal Procedure

Refer to Figure 2-26 for this procedure.

1. Disconnect the power cord.
2. Remove the covers from the signal generator. Refer to ["Outer Instrument Cover" on page 2-4](#) and ["Inner Instrument Cover" on page 2-6](#).
3. Position the signal generator with the A31 Motherboard facing away from you and the RF deck on top.
4. Using the 5/16" open ended wrench, disconnect the A24 High Band Detector from the A24 40 GHz High Band Coupler.
5. Using the 5/16" open ended wrench, disconnect the W30 and W24 RF cables from the A24 40 GHz High Band Coupler's input and output.
6. Disconnect the A25BW1 bias board power cable from the A26 MID J12.
7. Using the T-10 driver, remove the two screws (1) that attach the coupler to the top panel.
8. Remove the A24 40 GHz High Band Coupler.

### Replacement Procedure

- Reverse the order of the removal procedure.
- Torque all T-10 screws to 9 in-lbs.
- Torque all RF connectors to 8 in-lbs.
- Perform the post-repair adjustments and performance tests that pertain to this removal procedure.



Figure 2-26 A24 40 GHz High Band Coupler

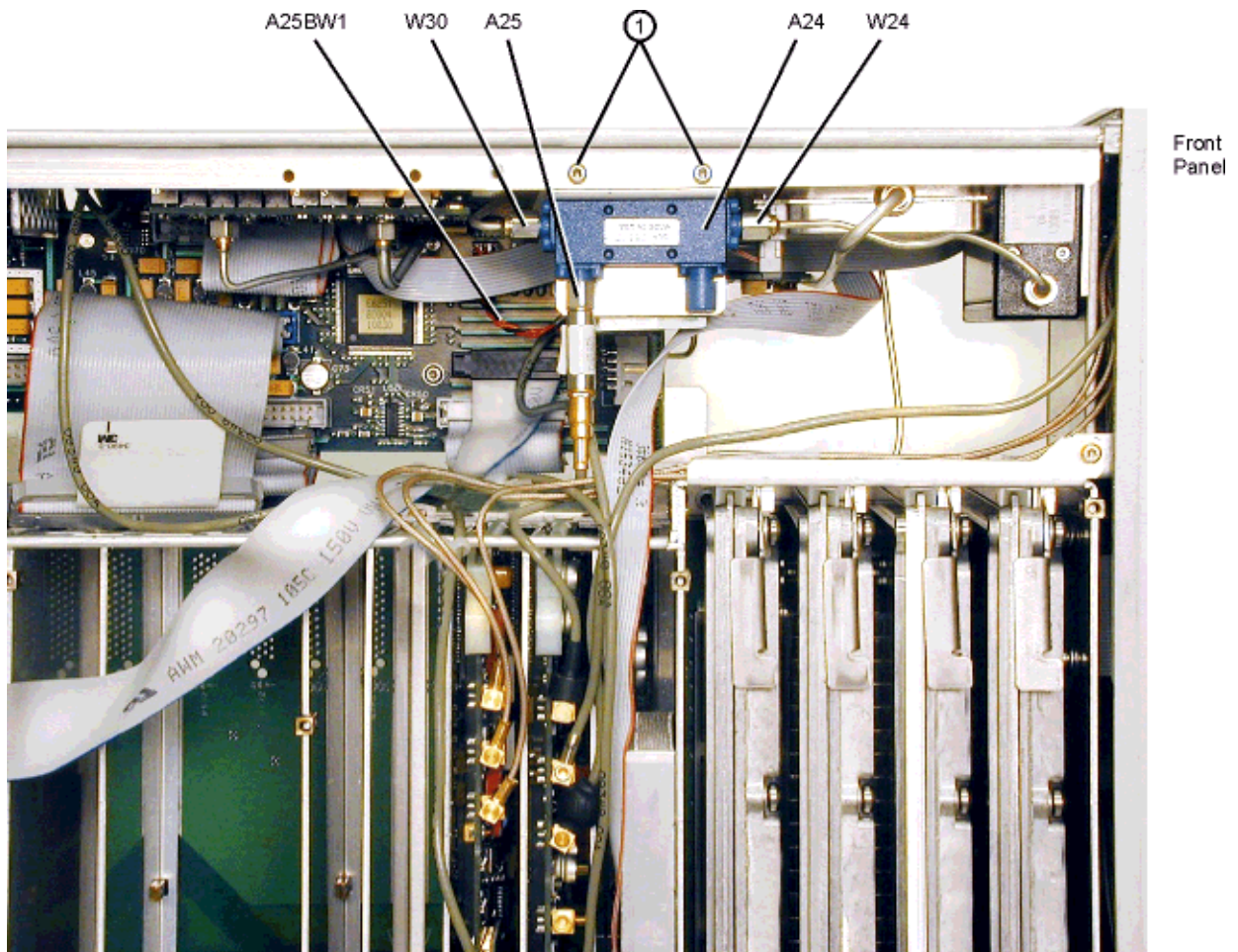

00050a

## **A25 20 GHz High Band Detector with A25B Detector Bias Board (E8241A and E8251A Models Only)**

### **Tools Required**

- T-8 driver
- T-10 driver
- 5/16" open ended wrench

### **Removal Procedure**

Refer to Figure 2-27 for this procedure.

1. Disconnect the power cord.
2. Remove the covers from the signal generator. Refer to "[Outer Instrument Cover](#)" on page 2-4 and "[Inner Instrument Cover](#)" on page 2-6.
3. Position the signal generator with the A31 Motherboard facing away from you and the RF deck on top.
4. Using the 5/16" open ended wrench, disconnect the A25 High Band Detector from the A25 20 GHz High Band Coupler.
5. Disconnect the W30 and W24 RF cables from the A25 20 GHz High Band Coupler.
6. Disconnect the A25BW1 bias board power cable.
7. Using the T-10 driver, remove the two screws that attach the coupler to the side panel.
8. Remove the coupler with the bias board from the chassis.
9. Using the T-8 driver, remove the two screws that attach the bias board to the sheet metal.
10. Remove the bias board.

### **Replacement Procedure**

- Reverse the order of the removal procedure.
- Torque all T-8 screws to 9 in-lbs.
- Torque all T-10 screws to 9 in-lbs.
- Torque all RF connectors to 8 in-lbs.
- Perform the post-repair adjustments and performance tests that pertain to this removal procedure.

Figure 2-27 A25 20 GHz High Band Detector with Bias Board

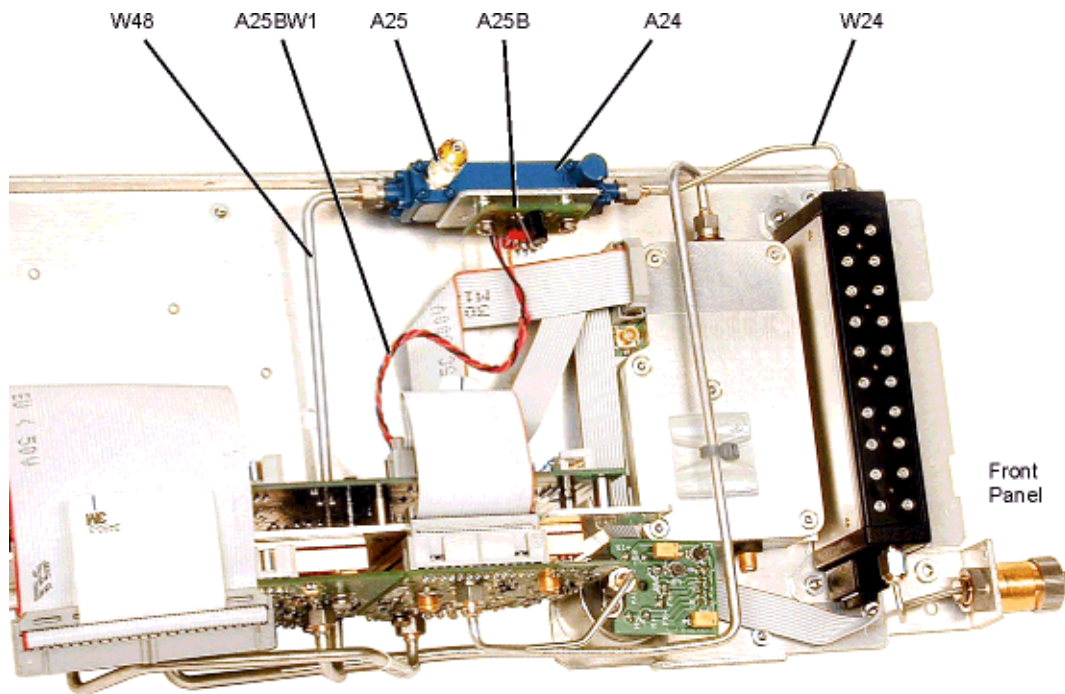

se074a

## **A25 40 GHz High Band Detector with A25B Detector Bias Board (E8244A and E8254A Models Only)**

### **Tools Required**

- T-8 driver
- T-10 driver
- 5/16" open ended wrench

### **Removal Procedure**

Refer to Figure 2-28 for this procedure.

1. Disconnect the power cord.
2. Remove the covers from the signal generator. Refer to ["Outer Instrument Cover" on page 2-4](#) and ["Inner Instrument Cover" on page 2-6](#).
3. Position the signal generator with the A31 Motherboard facing away from you and the RF deck on top.
4. Using the 5/16" open ended wrench, disconnect the A25 High Band Detector from the A25 High Band Coupler.
5. Disconnect the W30 and W24 RF cables from the A25 40 GHz High Band Coupler.
6. Disconnect the A25BW1 bias board power cable.
7. Using the T-10 driver, remove the two screws that attach the coupler to the side panel.
8. Remove the coupler with the bias board from the chassis.
9. Using the T-8 driver, remove the two screws that attach the bias board to the sheet metal.
10. Remove the bias board.

### **Replacement Procedure**

- Reverse the order of the removal procedure.
- Torque all T-8 screws to 9 in-lbs.
- Torque all T-10 screws to 9 in-lbs.
- Torque all RF connectors to 8 in-lbs.
- Perform the post-repair adjustments and performance tests that pertain to this removal procedure.

Figure 2-28 A25 40 GHz High Band Detector with Bias Board

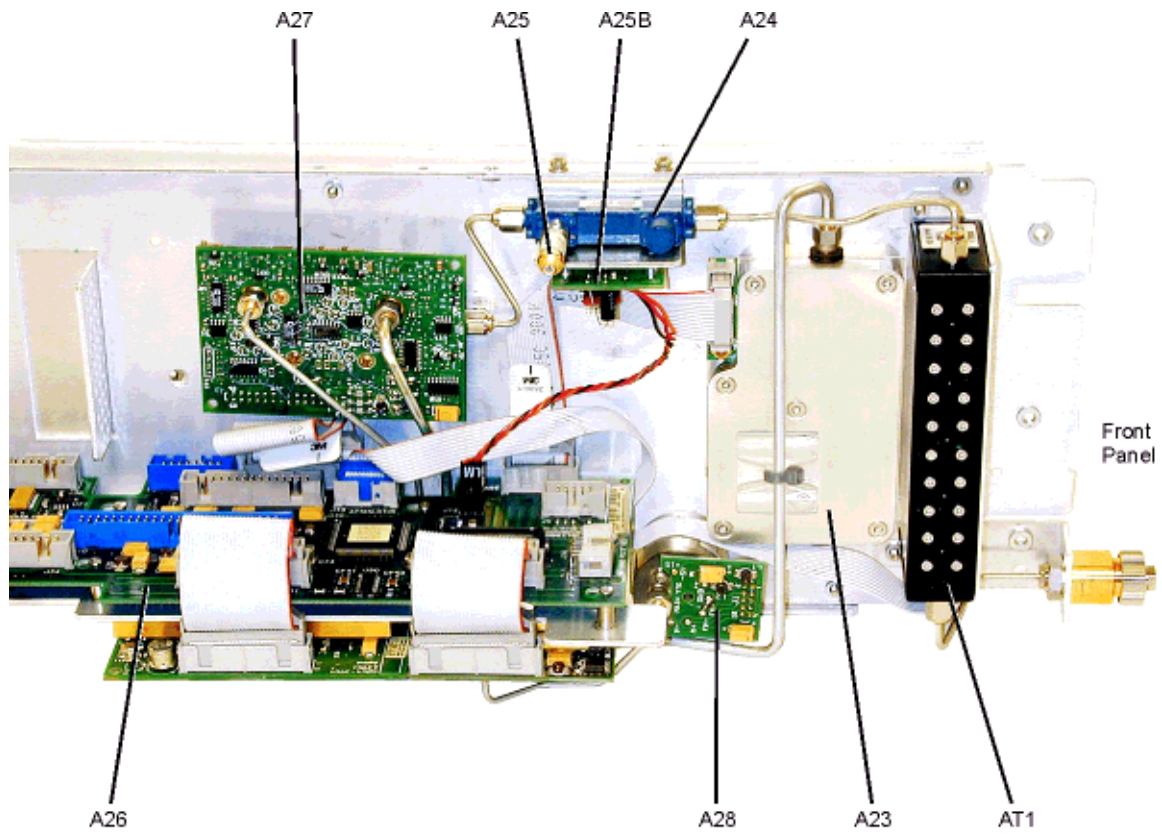

se947a

## A26 MID (Microcircuit Interface Deck)

### Tools Required

- T-10 driver

### Removal Procedure

Refer to Figure 2-29 for this procedure.

1. Disconnect the power cord.
2. Remove the covers from the signal generator. Refer to "Outer Instrument Cover" on page 2-4 and "Inner Instrument Cover" on page 2-6.
3. Position the signal generator with the A31 Motherboard facing you and the RF deck on top.
4. Disconnect the W28 ribbon cable from A26J15.
5. If you have a 40 GHz signal generator, disconnect the W29 ribbon cable from A23J33.
6. Disconnect the W20 ribbon cable from A26J20.
7. Disconnect the W33 ribbon cable from A26J32.
8. Disconnect the W34 ribbon cable from A26J31.
9. Disconnect the W35 ribbon cable from A26J10.
10. Disconnect the W36 ribbon cable from A26J13.
11. Disconnect the A25BW1 power cable from A26J12.
12. Disconnect the W19 ribbon cable from A26J30.
13. Using the T-10 driver, loosen the screw that secures the A26 MID to the RF deck.
14. Slide the A26 MID towards the front panel until the locking standoffs are free.
15. Remove the A26 MID from the RF bracket.

### Replacement Procedure

- Reverse the order of the removal procedure.
- Torque all T-10 screws to 9 in-lbs.
- Perform the post-repair adjustments and performance tests that pertain to this removal procedure.

Figure 2-29 A26 MID

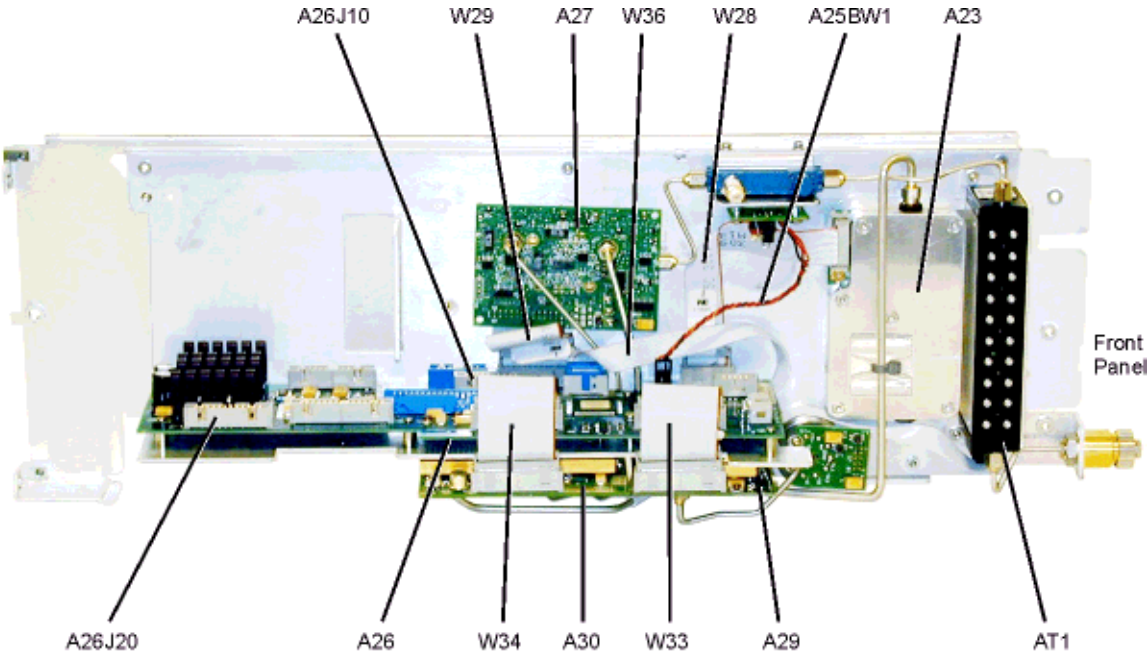

se966a

## A27 40 GHz Doubler (E8244A and E8254A Models Only)

### Tools Required

- T-10 driver
- 5/16" open ended wrench

### Removal Procedure

Refer to Figure 2-30 for this procedure.

1. Disconnect the power cord.
2. Remove the covers from the signal generator. Refer to ["Outer Instrument Cover" on page 2-4](#) and ["Inner Instrument Cover" on page 2-6](#).
3. Position the signal generator with the A31 Motherboard facing away from you and the RF deck on top.
4. Using the 5/16" open ended wrench, disconnect the W30 RF cable from the A27 40 GHz Coupler.
5. Using the 5/16" open ended wrench, disconnect the W31 RF cable from A27J3.
6. Using the 5/16" open ended wrench, disconnect the W32 RF cable from A27J1.
7. Using the T-10 driver, remove the two screws that attach the A27 40 GHz Doubler to the side panel.
8. Disconnect the W29 ribbon cable from the A27 40 GHz Doubler's board.
9. Remove the A27 40 GHz Doubler from the RF deck.

### Replacement Procedure

- Reverse the order of the removal procedure.
- Torque all T-10 screws to 9 in-lbs.
- Torque all RF connectors to 8 in-lbs.
- Perform the post-repair adjustments and performance tests that pertain to this removal procedure.



Figure 2-30

A27 40 GHz Doubler

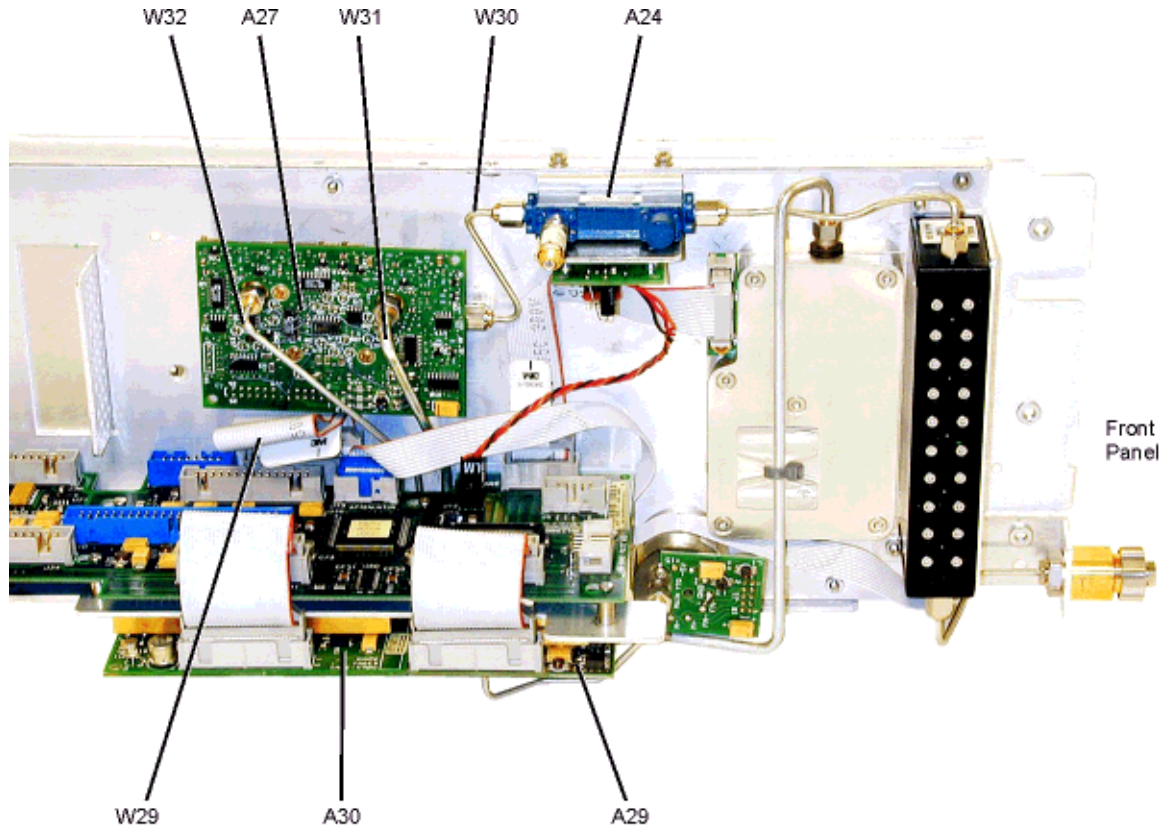

se967a

## A28 YIG Oscillator

### Tools Required

- T-10 driver
- 5/16" open ended wrench

### Removal Procedure

Refer to Figure 2-31 for this procedure.

1. Disconnect the power cord.
2. Remove the covers from the signal generator. Refer to ["Outer Instrument Cover" on page 2-4](#) and ["Inner Instrument Cover" on page 2-6](#).
3. Position the signal generator with the A31 Motherboard facing you and the RF deck on top.
4. Disconnect the W12 ribbon cable from the A28 YIG Oscillator's driver board.
5. Using the 5/16" open ended wrench, disconnect the W38 RF cable from the A28 YIG Oscillator.
6. Using the T-10 driver, remove the two screws (1) that attach the A28 YIG Oscillator to the side panel.
7. Remove the A28 YIG Oscillator.

### Replacement Procedure

- Reverse the order of the removal procedure.
- Torque all T-10 screws to 9 in-lbs.
- Torque all RF connectors to 8 in-lbs.
- Perform the post-repair adjustments and performance tests that pertain to this removal procedure.

Figure 2-31 A28 YIG Oscillator

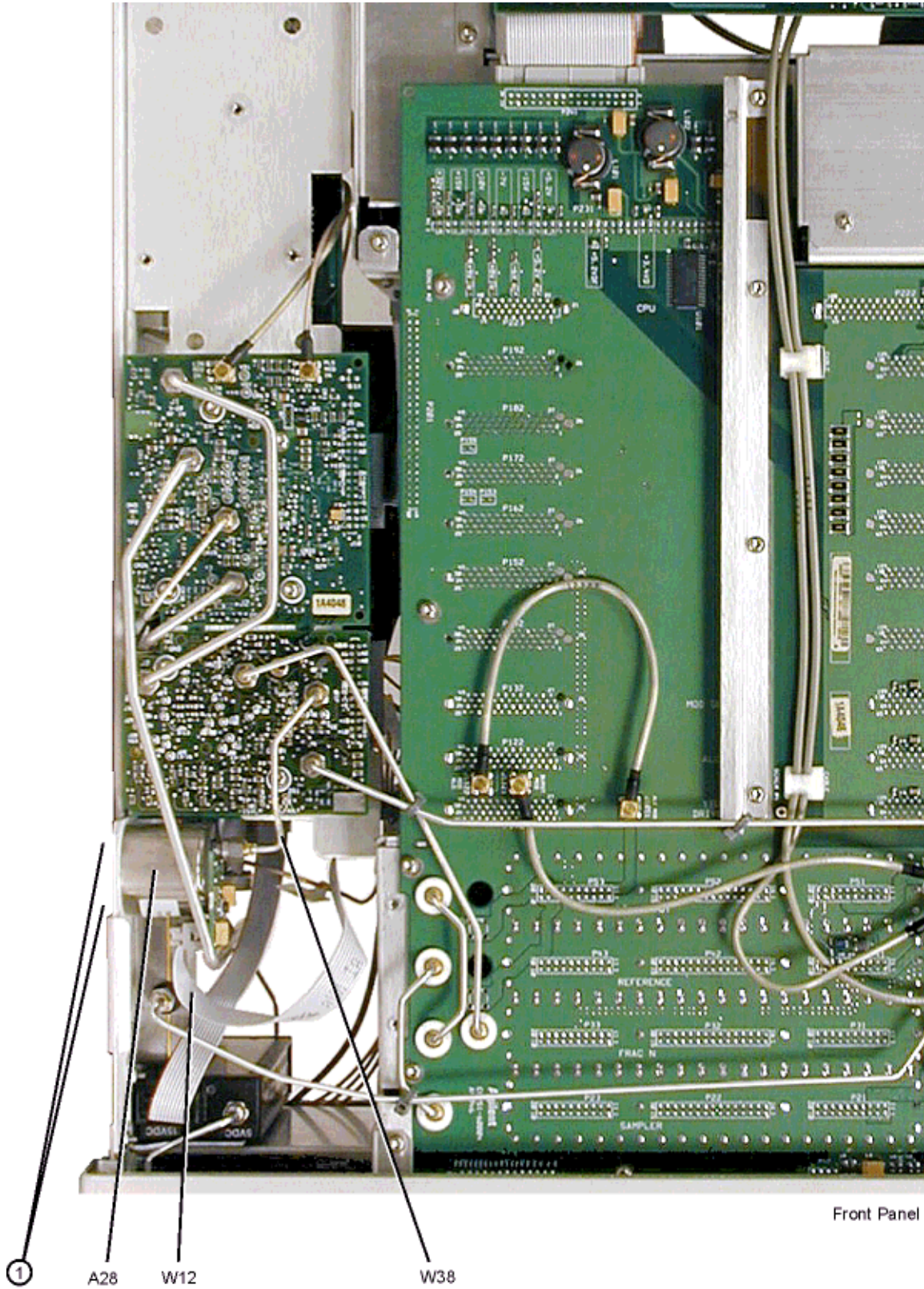

se937a

## A29 20 GHz Doubler

### Tools Required

- T-10 driver
- 5/16" open ended wrench

### Removal Procedure

Refer to Figure 2-32 for this procedure.

1. Disconnect the power cord.
2. Remove the covers from the signal generator. Refer to ["Outer Instrument Cover" on page 2-4](#) and ["Inner Instrument Cover" on page 2-6](#).
3. Position the signal generator with the A31 Motherboard facing you and the RF deck on top.
4. Disconnect the W32 ribbon cable from the A29 20 GHz Doubler.
5. Disconnect the W38, W39, W40 and W41 RF cables from the A29 20 GHz Doubler.
6. Using the T-10 driver, remove the two screws (1) that attach the A29 20 GHz Doubler to the RF deck.
7. Remove the A29 20 GHz Doubler from the RF deck.

### Replacement Procedure

- Reverse the order of the removal procedure.
- Torque all T-10 screws to 9 in-lbs.
- Torque all RF connectors to 8 in-lbs.
- Perform the post-repair adjustments and performance tests that pertain to this removal procedure.

Figure 2-32 A29 20 GHz Doubler

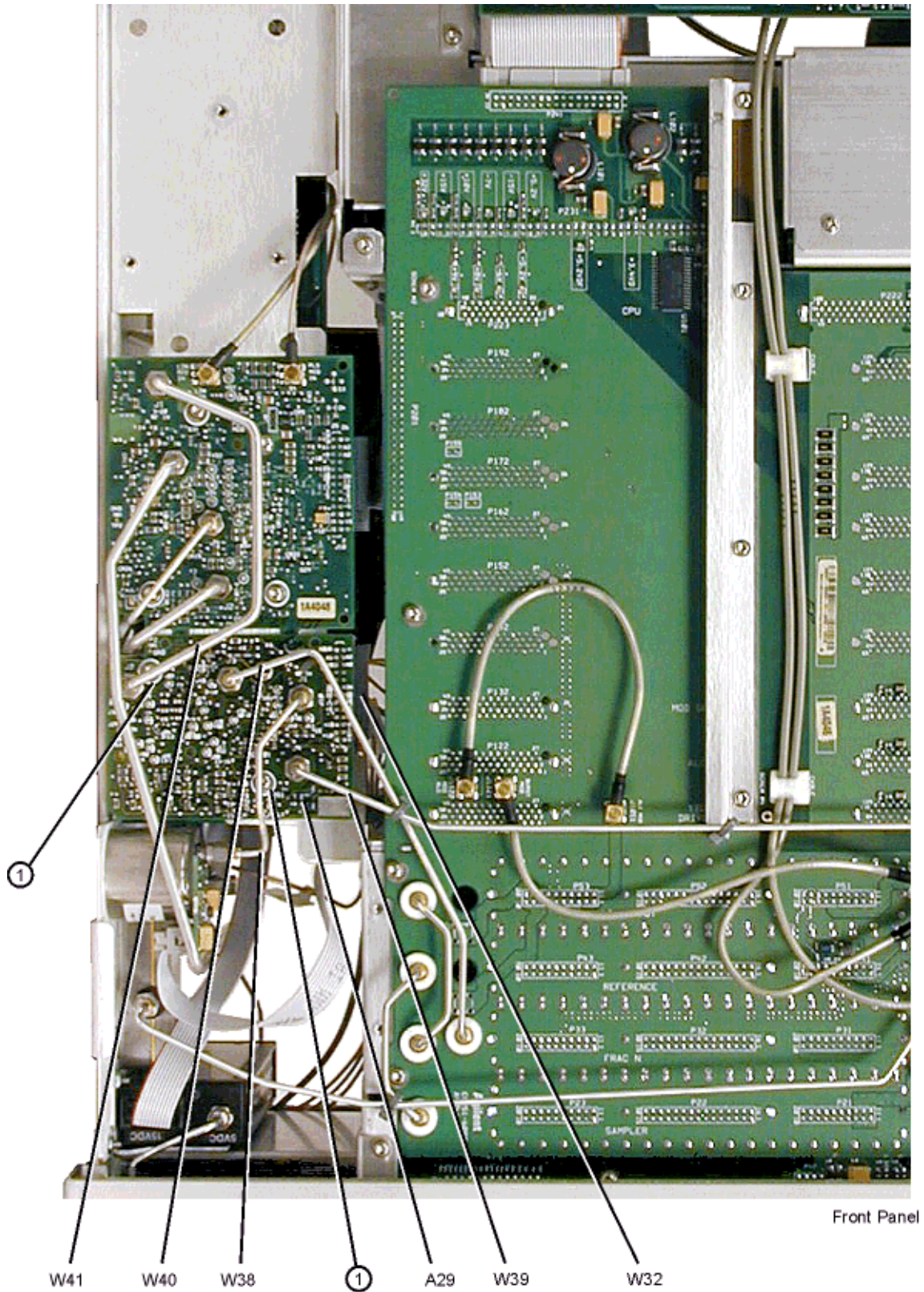

se936a

## A30 Modulation Filter (Standard and Option 1EA)

### Tools Required

- T-10 driver
- 5/16" open ended wrench

### Removal Procedure

Refer to Figure 2-33 for this procedure.

1. Disconnect the power cord.
2. Remove the covers from the signal generator. Refer to ["Outer Instrument Cover" on page 2-4](#) and ["Inner Instrument Cover" on page 2-6](#).
3. Position the signal generator with the A31 Motherboard facing away from you and the RF deck on top.
4. Disconnect the W33 ribbon cable from the A30 Modulator Filter.
5. Using the 5/16" open ended wrench, disconnect the W48 RF cable from A30J2.
6. Using the 5/16" open ended wrench, disconnect the W32 RF cable from A30J4.
7. Using the 5/16" open ended wrench, disconnect the W27 RF cable from A30J3.
8. Using the 5/16" open ended wrench, disconnect the W41 RF cable from A30J1.
9. Disconnect the W13 flexible cable from A30J6.
10. Disconnect the W17 flexible cable from A30J7.
11. Using the T-10 driver, remove the three screws (1) that attach the A30 Modulator Filter to the RF bracket.
12. Remove the A30 Modulator Filter from the RF deck.

### Replacement Procedure

- Reverse the order of the removal procedure.
- Torque all T-10 screws to 9 in-lbs.
- Torque all RF connectors to 8 in-lbs.
- Perform the post-repair adjustments and performance tests that pertain to this removal procedure.

Figure 2-33 A30 Modulator Filter

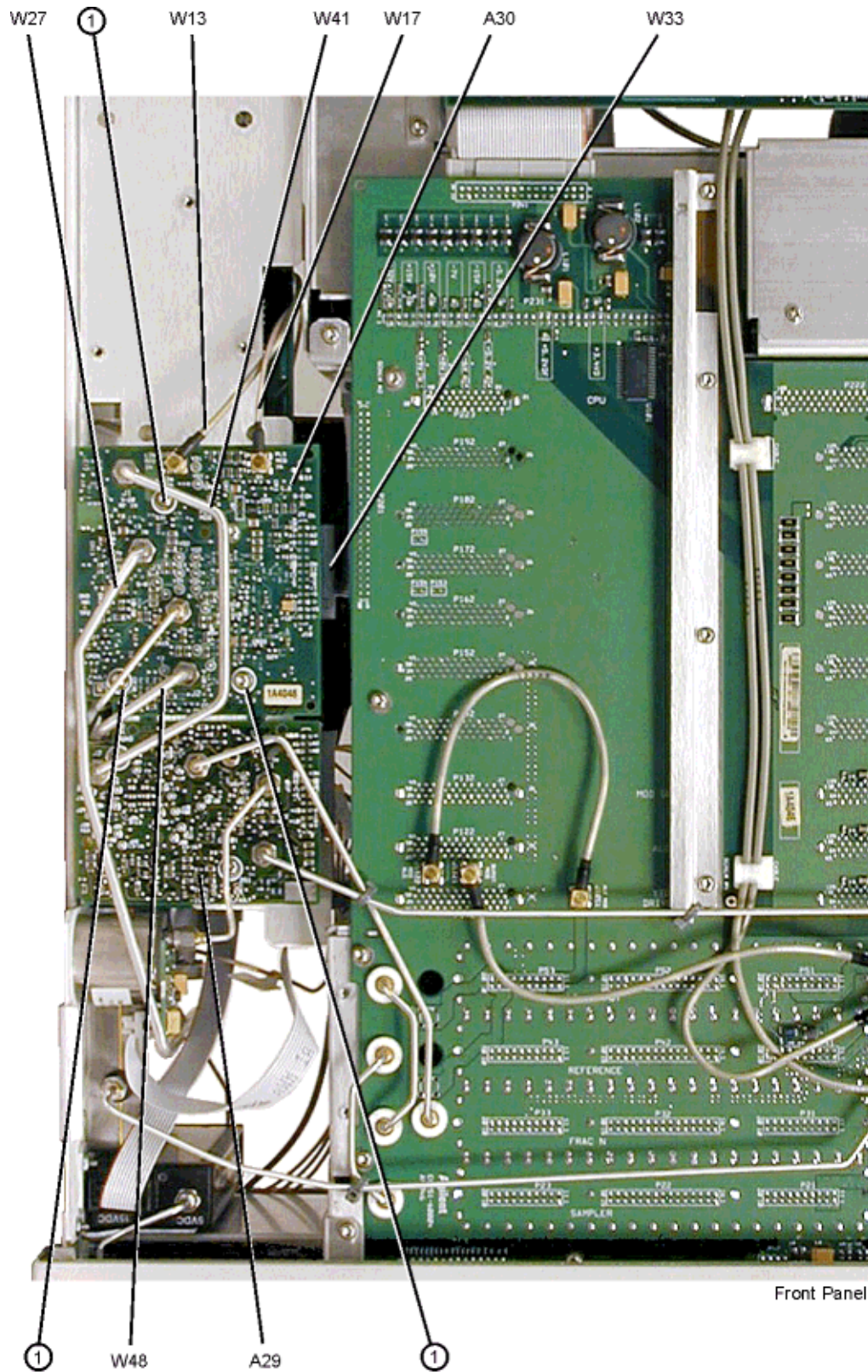

## A31 Motherboard

### Tools Required

- T-10 driver
- 5/16" open ended wrench
- needle-nose plier

### Removal Procedure

Refer to Figure 2-34 for this procedure.

1. Disconnect the power cord.
2. Remove the covers from the signal generator. Refer to ["Outer Instrument Cover" on page 2-4](#) and ["Inner Instrument Cover" on page 2-6](#).
3. Position the signal generator with the A31 Motherboard facing you and the RF deck on top.
4. Remove the front panel. Refer to ["Front Panel" on page 2-8](#).
5. Remove the assemblies that are inserted into the A31 Motherboard. Refer to ["A5 Sampler" on page 2-20](#), ["A9 YIG Driver" on page 2-28](#), ["A10 ALC" on page 2-31](#), ["A11 Pulse/Analog Modulation Generator" on page 2-33](#), and ["A18 CPU" on page 2-35](#).
6. Disconnect the W37 RF cable from the A23 Low Band Coupler/Detector.
7. Disconnect the W39 and W40 RF cables from the A29 20 GHz Doubler J4 and J3.
8. Disconnect the W10, W11, W21, and W22 flexible cables from the A31 Motherboard J1031, J1021, J1043, and J1042.
9. Using the T-10 driver, remove the 15 screws (1) that hold the A31 Motherboard to the chassis.
10. Disconnect the W35 ribbon cable from the A26 MID.
11. Disconnect the W23 ribbon cable from the A21 Rear Panel Interface while removing the A31 Motherboard from the chassis.

### Replacement Procedure

- Reverse the order of the removal procedure.
- Torque all T-10 screws to 9 in-lbs.
- Torque all RF connectors to 8 in-lbs.
- Perform the post-repair adjustments and performance tests that pertain to this removal procedure.



Figure 2-34

A31 Motherboard

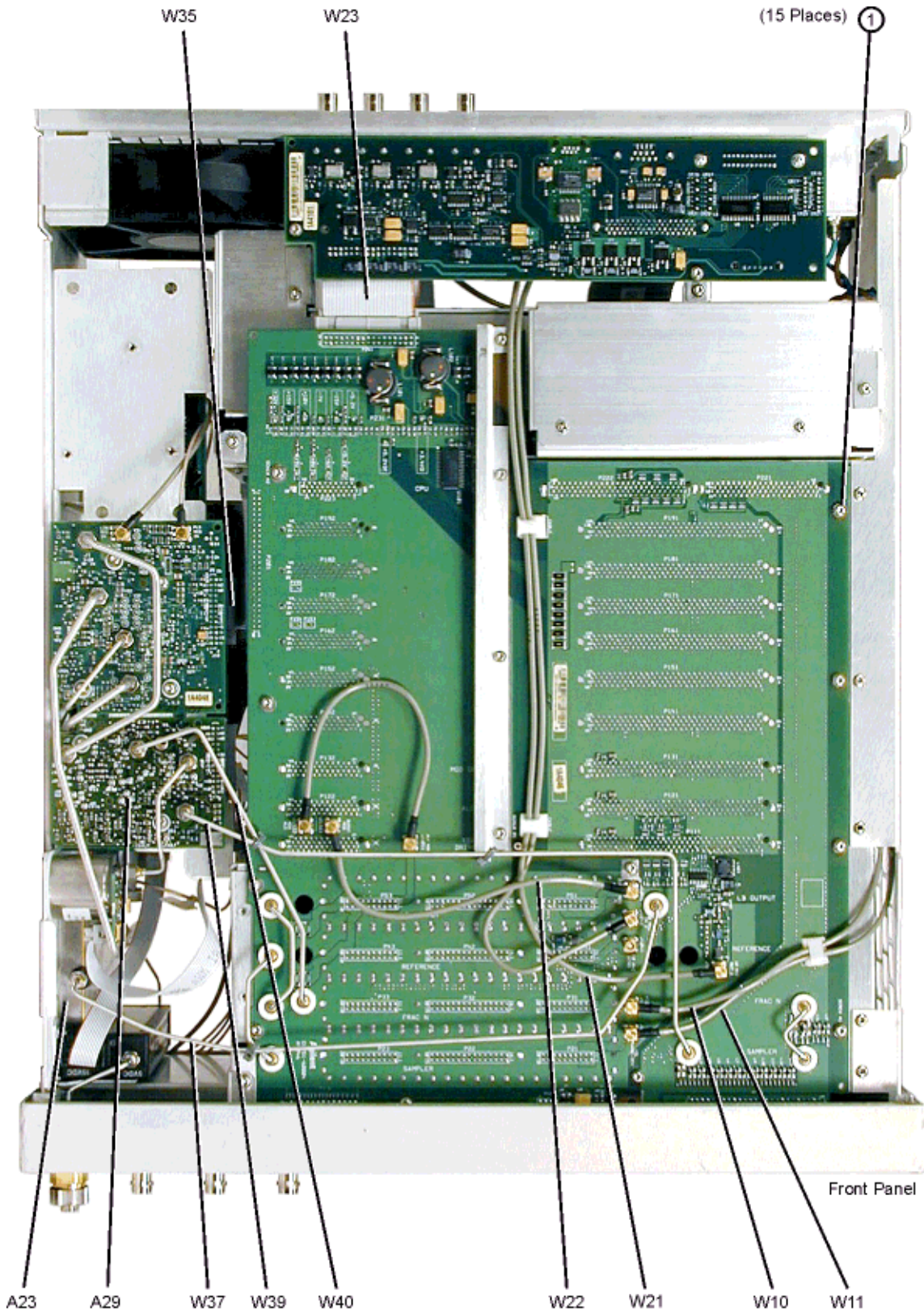

ca QR 1a

## A32 10 MHz Crystal Oscillator (Option UNJ)

### Tools Required

- T-10 driver
- needle-nose plier

### Removal Procedure

Refer to Figure 2-35 for this procedure.

1. Disconnect the power cord.
2. Remove the covers from the signal generator. Refer to ["Outer Instrument Cover" on page 2-4](#) and ["Inner Instrument Cover" on page 2-6](#).
3. Position the signal generator with the A21 Rear Panel facing you.
4. Using the needle-nose plier, disconnect the W47 flexible cable (A31 Motherboard J1041) from A32J2.
5. Using the needle-nose plier, disconnect the W48 flexible cable (Rear Panel 10 MHz EFC) from A32J1.
6. Disconnect the A32W1 bias cable from the A21 Rear Panel Interface P2.
7. Using the T-10 driver, remove the three screws (1) that attach the A32 10 MHz Crystal Oscillator to the rear panel.
8. Remove the A32 10 MHz Crystal Oscillator.

### Replacement Procedure

- Reverse the order of the removal procedure.
- Torque all T-10 screws to 9 in-lbs.
- Perform the post-repair adjustments and performance tests that pertain to this removal procedure.

Figure 2-35 A32 Crystal Oscillator

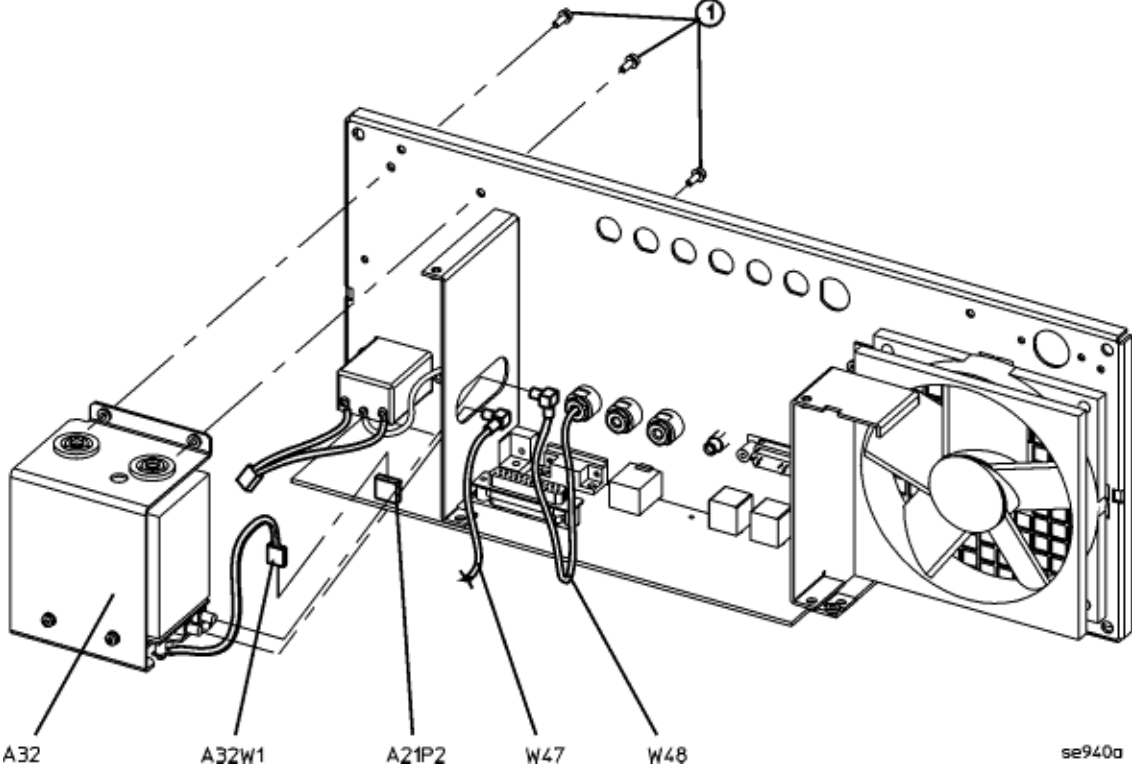

## **B1 Fan**

### **Tools Required**

- T-10 driver

### **Removal Procedure**

Refer to Figure 2-36 for this procedure.

1. Disconnect the power cord.
2. Remove the covers from the signal generator. Refer to ["Outer Instrument Cover" on page 2-4](#) and ["Inner Instrument Cover" on page 2-6](#).
3. Position the signal generator with the rear panel facing you.
4. Using the T-10 driver, remove the four screws (1) that attach the B1 Fan to the rear panel.
5. Disconnect the fan cable (2) from the A21 Rear-Panel Interface P6.
6. Remove the B1 Fan by tilting it at an angle.

### **Replacement Procedure**

- Reverse the order of the removal procedure.
- Torque all T-10 screws to 9 in-lbs.
- Perform the post-repair adjustments and performance tests that pertain to this removal procedure.

Figure 2-36 B1 Fan

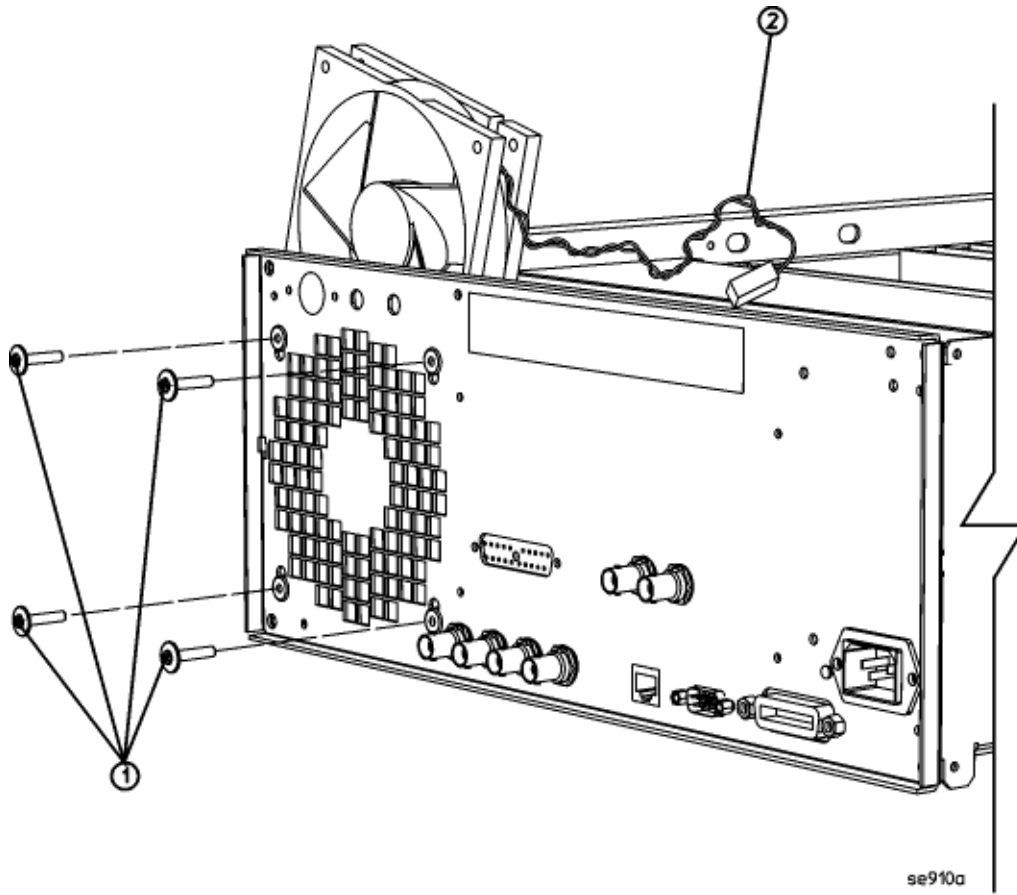



---

## **3 Replaceable Parts**

## Ordering Information

To order a part, do the following:

1. Determine the part number.
2. Determine the quantity required.
3. Mail this information to the nearest Agilent Technologies office or, in the U.S., call the hotline number listed in the following section.

To order a part not listed in the replaceable parts lists, mail the following information to the nearest Agilent Technologies office or, in the United States, call the hotline number listed in the following section.

- the instrument model number
- the serial number and options, if any (see rear panel)
- a description of the part
- a description of the part's function
- the quantity required

### Call (800) 227-8164 to Order Parts Fast (U.S. Only)

When you have gathered the information required to place an order, contact Agilent Technologies' direct ordering team by calling the toll-free hotline number shown above. Orders may be placed Monday through Friday, 6 AM to 5 PM (Pacific Standard Time).

The parts specialists have direct on-line access to replacement parts inventory corresponding to the replaceable parts lists in this manual. Four day delivery time is standard; there is a charge for hotline one-day delivery.

This information applies to the United States only. Outside the United States, you must contact the nearest Agilent Technologies sales and service office.



---

## Save Money with Rebuilt-Exchange Assemblies

Under the rebuilt-exchange assembly program, certain factory-repaired and tested assemblies are available on a trade-in basis. These assemblies cost less than a new assembly, and meet all factory specifications required of a new assembly.

To find out which parts are available through this program, check the Agilent Parts data base when ordering.

The defective assembly must be returned for credit under the terms of the rebuilt-exchange assembly program. The figure below illustrates the assembly exchange procedure in flowchart format.

### Assembly Exchange Procedure

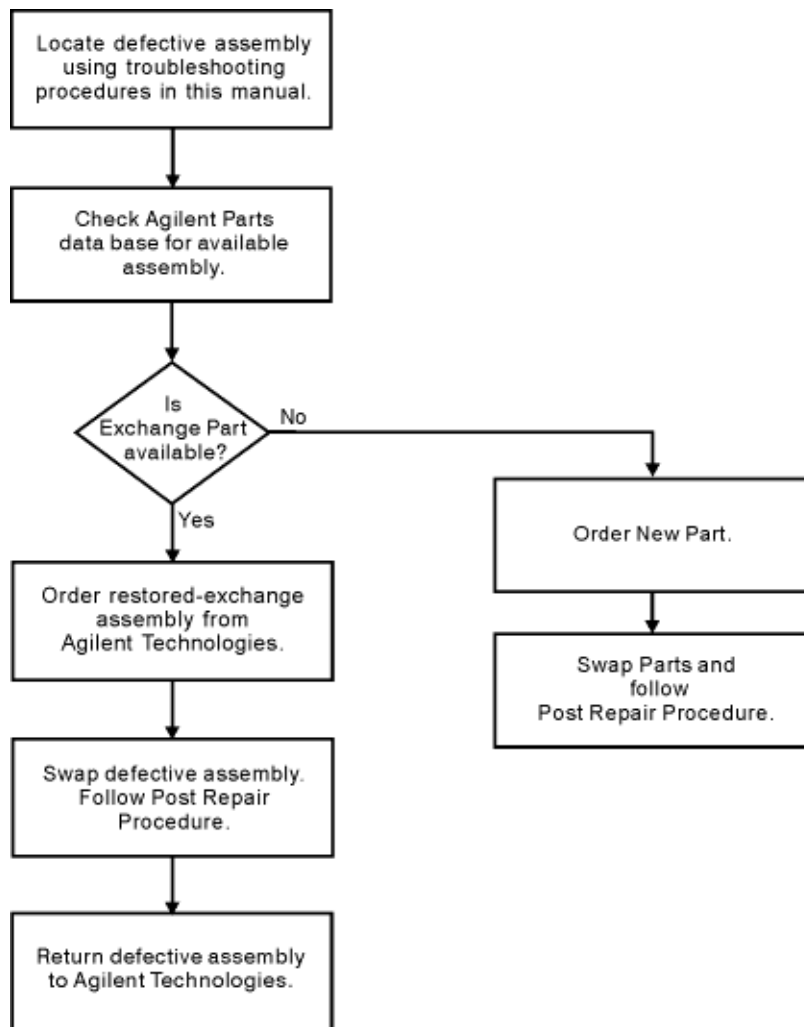

sk770a

## Shipping the Defective Assembly Back to Agilent Technologies

1. When you receive the rebuilt assembly, be careful not to damage the box in which it was shipped. You will use that box to return the defective assembly. The box you receive should contain the following:
  - the rebuilt assembly
  - an exchange assembly failure report
  - a return address label
2. Complete the failure report.
3. Place the failure report and the defective assembly in the box. Be sure to remove the enclosed return address label.
4. Seal the box with tape.

If you are inside the United States, stick the pre-printed return address label over the label that is already on the box and return the box to Agilent Technologies. (Agilent Technologies pays postage on boxes mailed within the United States.)

If you are outside the United States, do not use the return address label; instead, address the box to the nearest Agilent Technologies sales and service office.

## Abbreviations Used in Part Descriptions

This section defines the reference designators, and abbreviations, and option numbers that are used in the part descriptions throughout this chapter.

Reference Designator	Description
A	assembly
AT	attenuator
B	fan
BT	battery
CPU	central processing unit
CW	conical washer (screws)
DS	lamp
FL	flathead (screws)
GPIB	general purpose interface bus
Hex	hexagonal
J	electrical connector; jack
MID	microcircuit interface deck
P	electrical connector; plug
PN	panhead (screws)
Qty	quantity
RPG	rotary pulse generator
SMI	source module interface
TX	TORX recess (screws)
W	cable; transmission path; wire

Options	Description
1E1	Adds output step attenuator for extended range to -135 dBm
1EA	High RF output power +20 dBm at 20 GHz, +14 dBm at 40 GHz
1ED	Type-N RF output connector (20 GHz only)
UNJ	Improved close-in phase noise

## Major Assemblies

This section lists the major assemblies in the signal generator.

- A1 Keyboard [page 3-10](#)
- A2 Display [page 3-10](#)
- A2DS1 Backlight [page 3-10](#)
- A3 Power Switch [page 3-10](#)
- A4 Inverter [page 3-10](#)
- A5 Sampler [page 3-12](#)
- A6 Frac-N [page 3-12](#)
- A7 Reference (Standard) [page 3-12](#)
- A7 Reference (Option UNJ) [page 3-12](#)
- A8 Output [page 3-12](#)
- A9 YIG Driver [page 3-12](#)
- A10 ALC [page 3-12](#)
- A11 Pulse/Analog Modulation Generator (E8251A and E8254A Models Only) [page 3-12](#)
- A18 CPU [page 3-12](#)
- A18BT1 [page 3-20](#)
- A19 Power Supply [page 3-12](#)
- A20 SMI (Source Module Interface) [page 3-16](#)
- A21 Rear Panel Interface [page 3-16](#)
- A22 Line Module [page 3-16](#)
- AT1 115 dB Attenuator (Option 1E1) [page 3-17](#)
- A23 Low Band Coupler/Detector [page 3-17](#)
- A24 20 GHz High Band Coupler (E8241A and E8251A Models Only) [page 3-17](#)
- A24 40 GHz High Band Coupler (E8244A and E8254A Models Only) [page 3-17](#)
- A25 20 GHz High Band Detector (E8241A and E8251A Models Only) [page 3-17](#)
- A25 40 GHz High Band Detector (E8244A and E8254A Models Only) [page 3-17](#)
- A25B High Band Detector Bias Board [page 3-17](#)
- A26 MID (Microcircuit Interface Deck) [page 3-17](#)
- A27 40 GHz Doubler (E8244A and E8254A Models Only) [page 3-17](#)
- A28 YIG Oscillator [page 3-18](#)
- A29 20 GHz Doubler [page 3-18](#)
- A30 Modulation Filter with Standard Power [page 3-18](#)
- A30 Modulation Filter with High Power (Option 1EA) [page 3-18](#)
- A31 Motherboard [page 3-14](#)
- A32 10 MHz Crystal Oscillator (Option UNJ) [page 3-16](#)
- B1 Fan [page 3-16](#)
- RF Output Connector [page 3-51](#)
- Front Panel [page 3-38](#)
- Outer and Inner Instrument Covers [page 3-55](#)

### Major Assemblies Top View

This section shows the major assemblies of the signal generator from the top view.

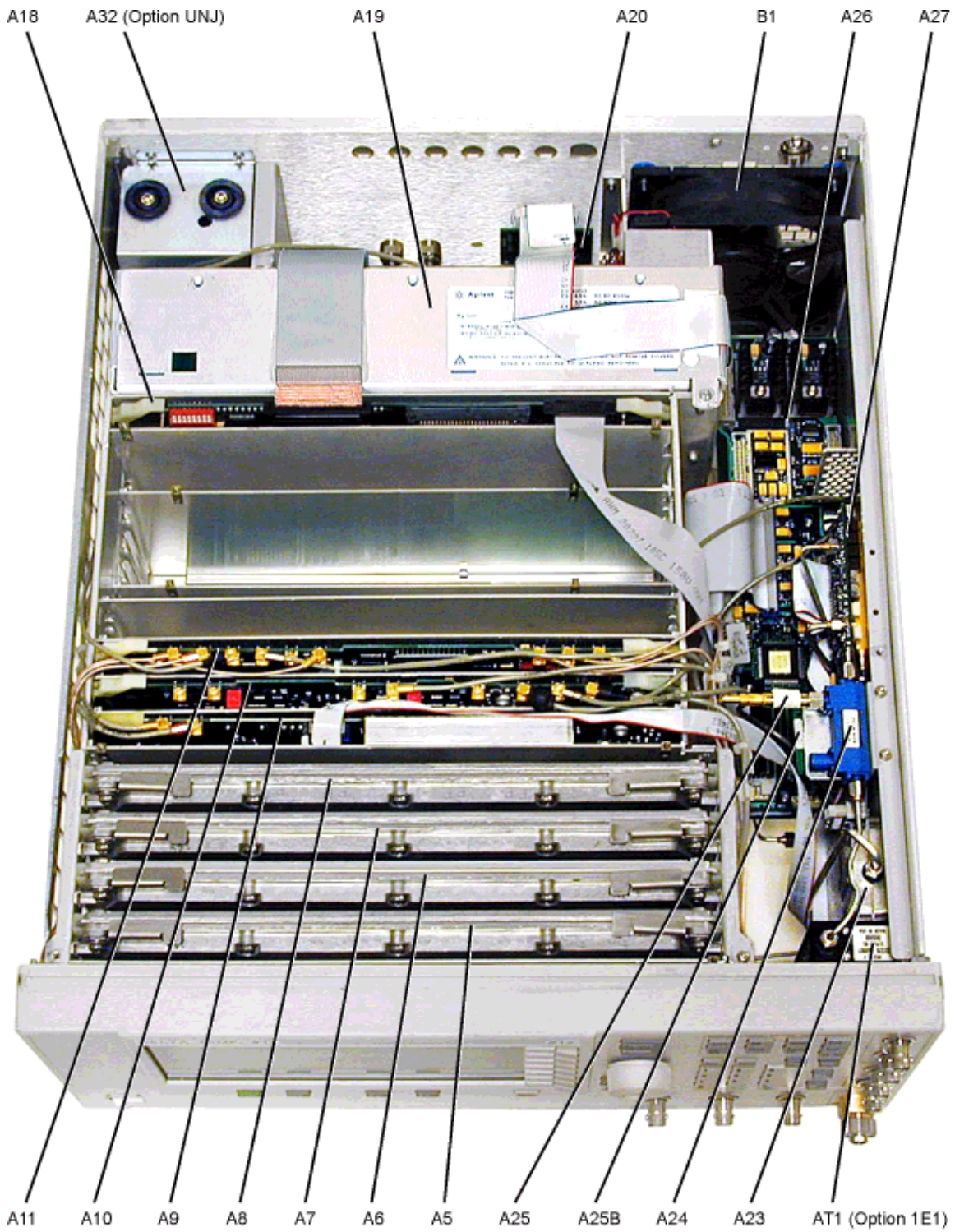

se932a

### Major Assemblies Bottom View

This section shows the major assemblies of the signal generator from the bottom view.

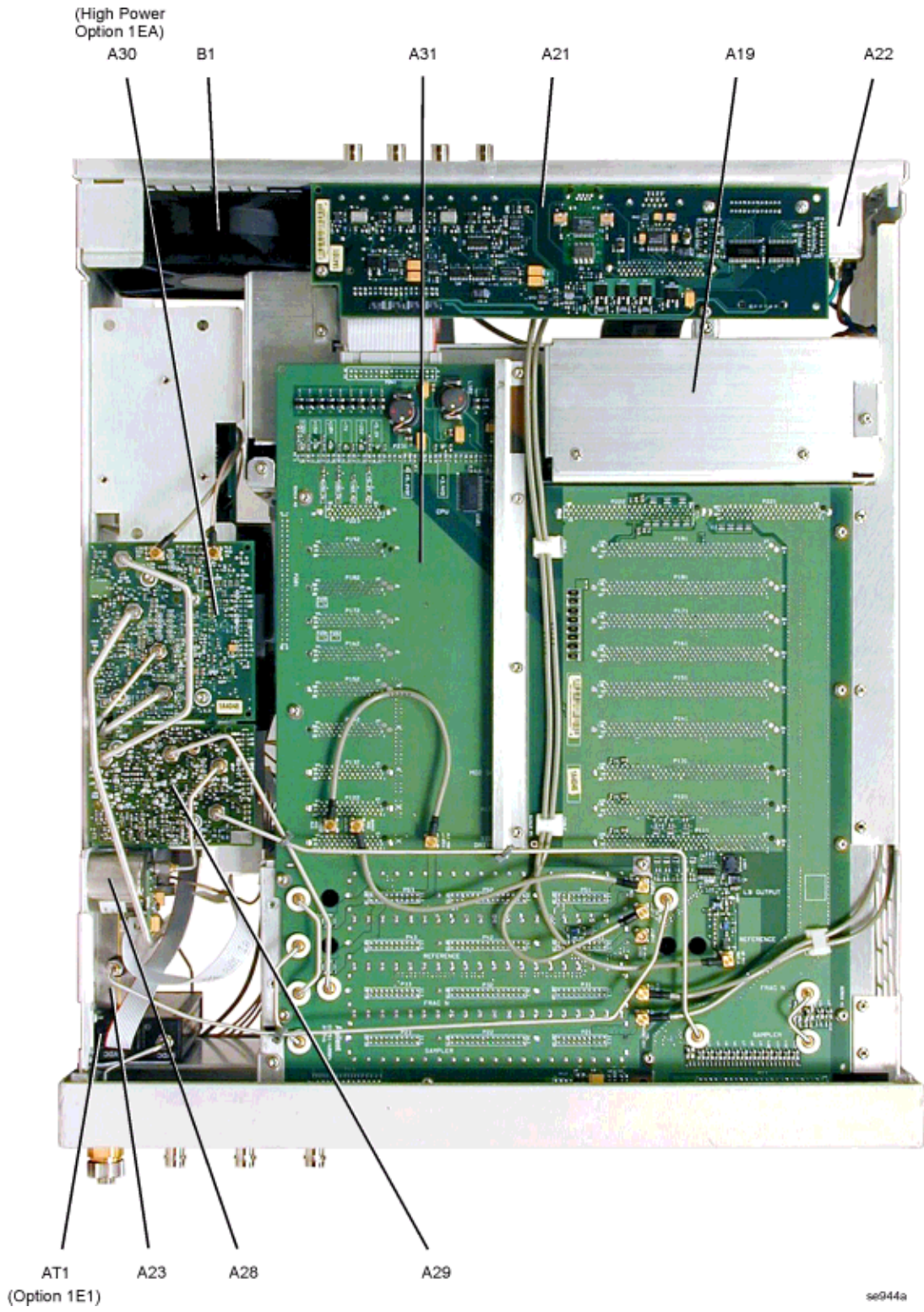

## Major Assemblies Microcircuit Deck View

This section shows the major assemblies of the signal generator's microcircuit deck.

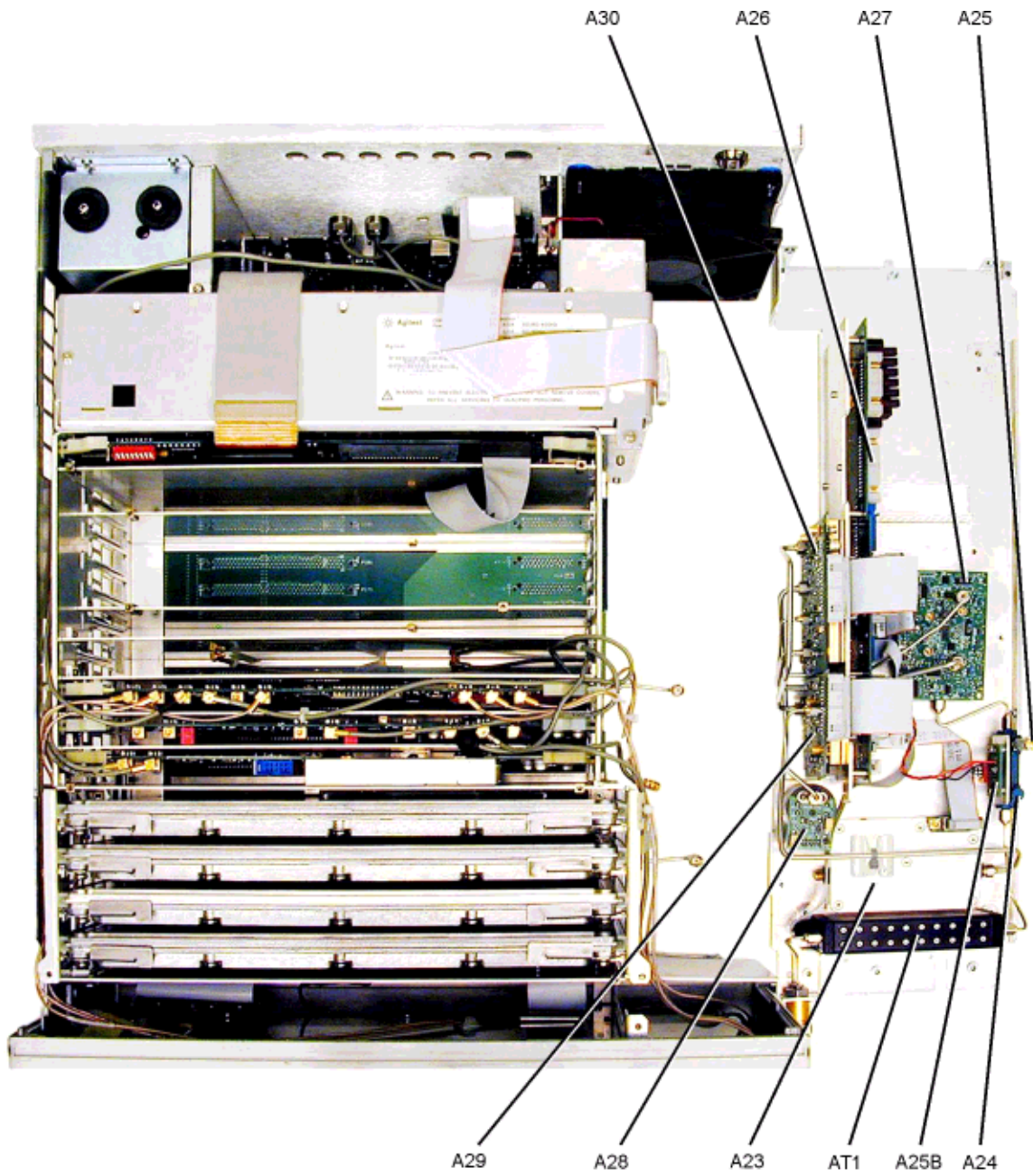

se943a

### Inside Front Panel View

**Table 3-1**                    **Inside Front Panel View**

<b>Reference Designator</b>	<b>Description</b>	<b>Qty</b>	<b>Part Number</b>
A1	Keyboard	1	E8251-60058
A2	Display	1	2090-0375
A2DS1	Backlight	1	1513-5204
A3	Power Switch	1	E8251-60042
A4	Inverter	1	0950-3757



Figure 3-1 Inside Front Panel View

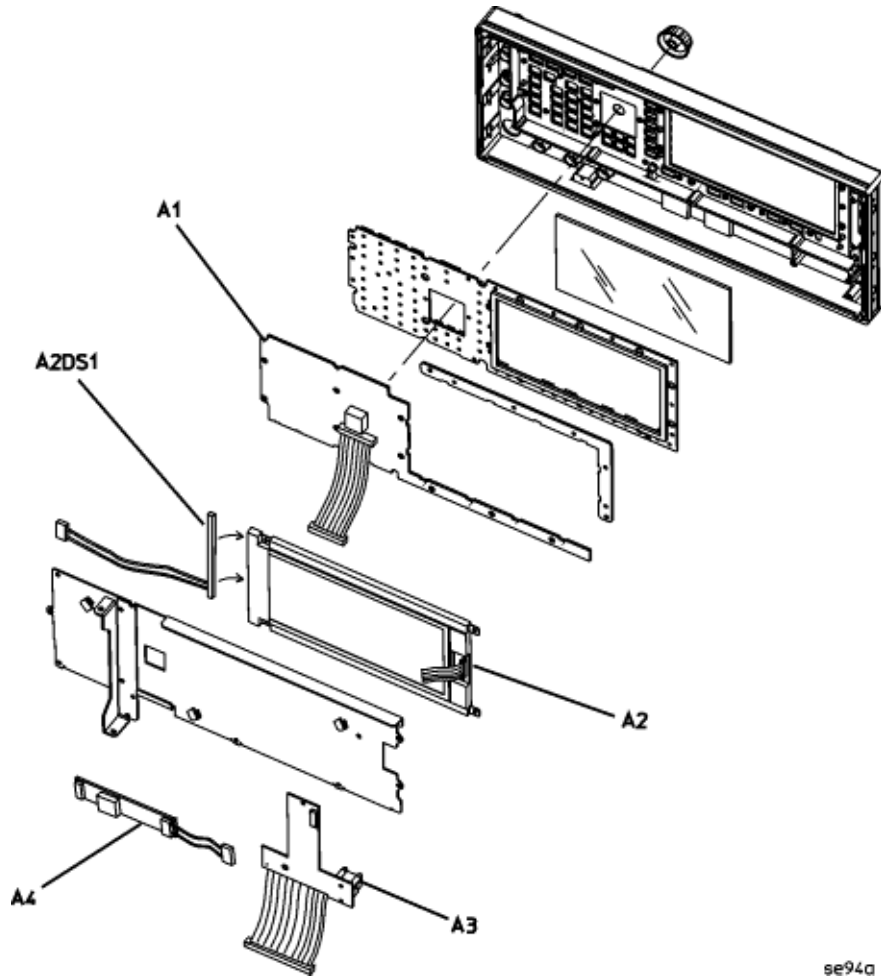

se94a

## Main Chassis Top View

**Table 3-2 Main Chassis Top View**

Reference Designator	Description	Qty	Part Number
A5	Sampler	1	E8251-60043
A6	Frac-N	1	E8251-60044
A7	Reference	1	E4423-60018
	Reference (Option UNJ)	1	E8251-60048
A8	Output	1	E8251-60046
A9	YIG Driver	1	E8251-60007
A10	ALC	1	E8251-60005
A11	Pulse/Analog Modulation Generator (E8251A and E8254A Models Only)	1	E8251-60011
A12	N/A		N/A
A13	N/A		N/A
A14	N/A		N/A
A15	N/A		N/A
A16	N/A		N/A
A17	N/A		N/A
A18	CPU	1	E8251-60006
A19	Power Supply	1	0950-3700

Figure 3-2 Main Chassis Top View

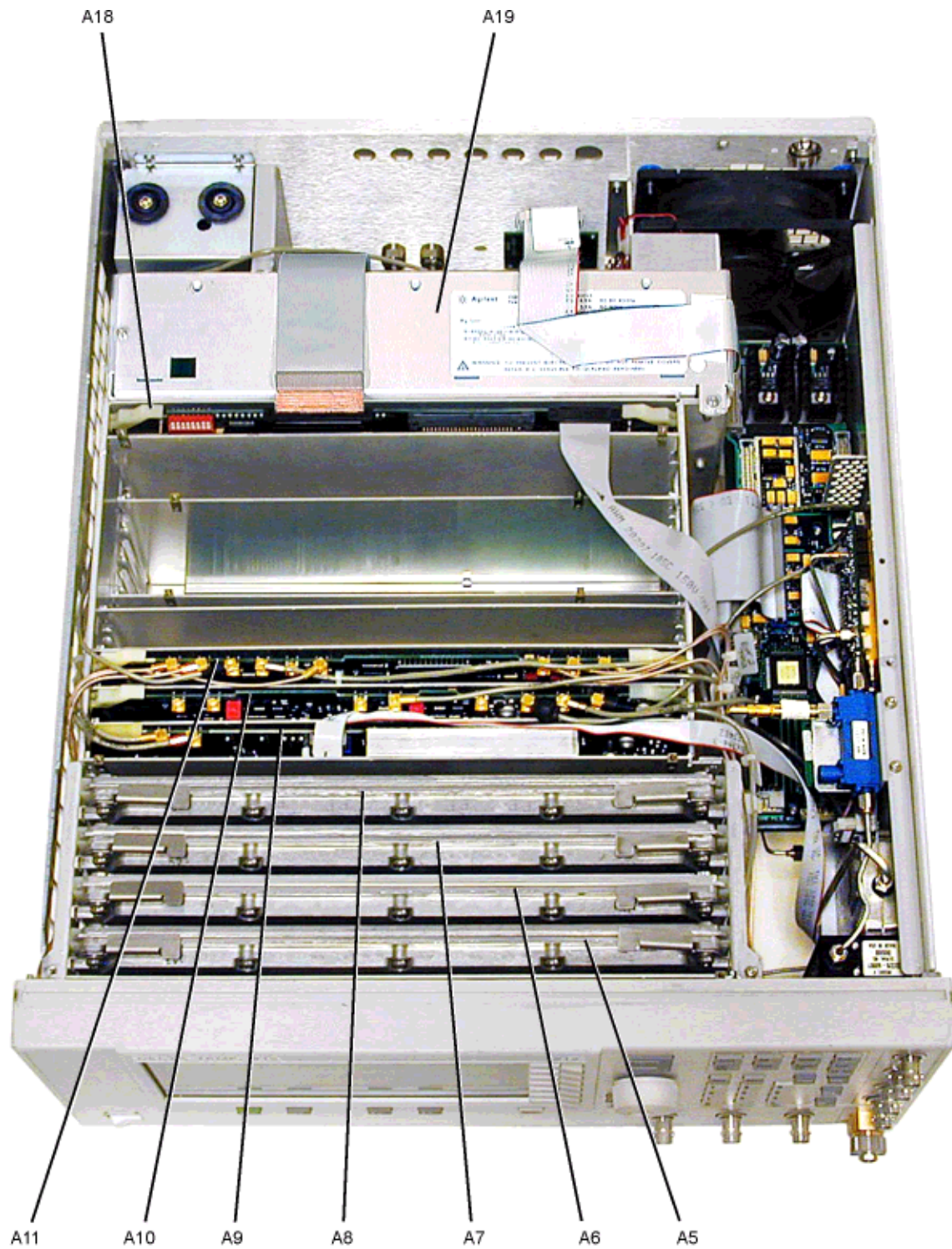

se945a

### Main Chassis Bottom View

**Table 3-3**                      **Main Chassis Bottom View**

<b>Reference Designator</b>	<b>Description</b>	<b>Qty</b>	<b>Part Number</b>
A31	Motherboard	1	E8251-60004

Figure 3-3 Main Chassis Bottom View

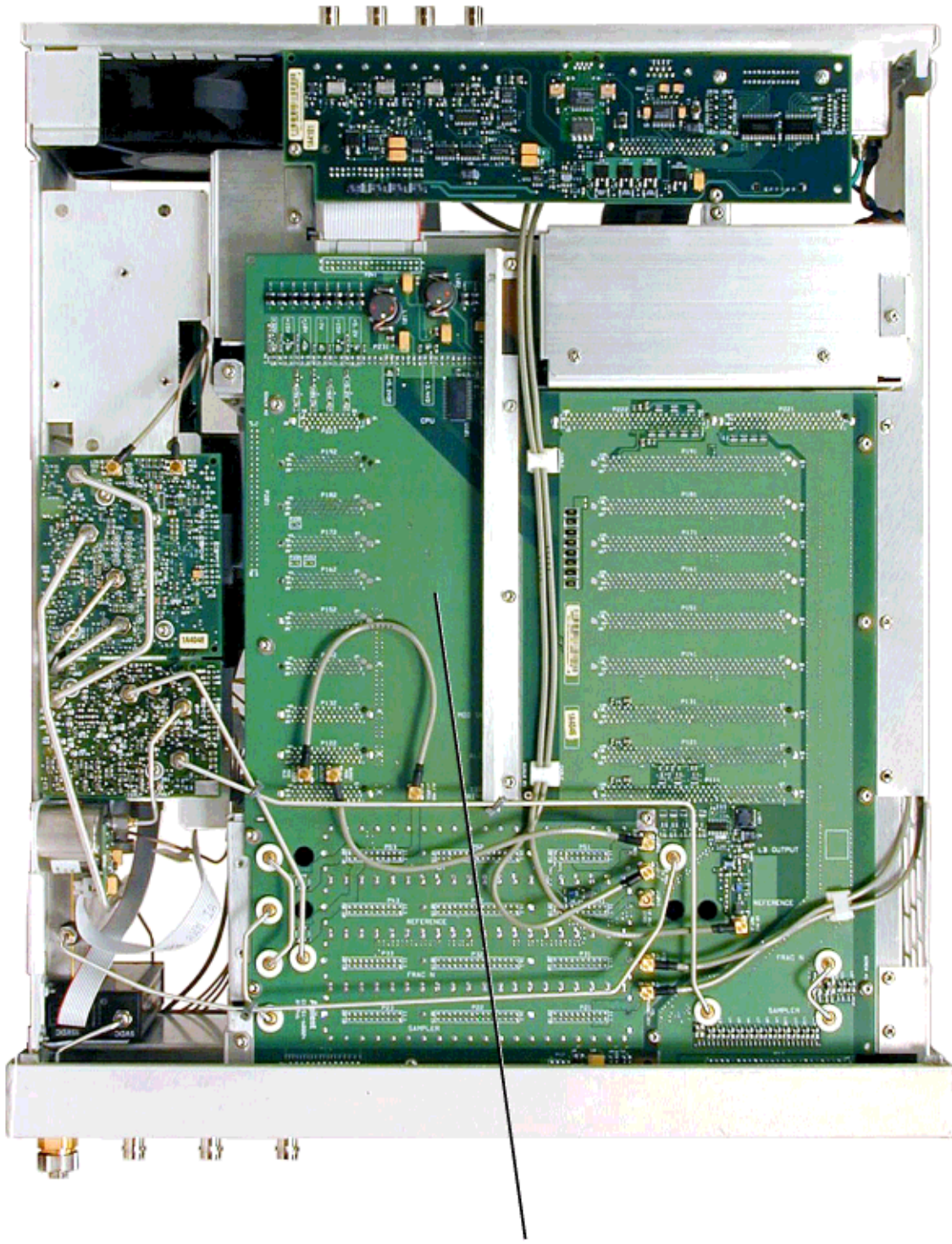

A31

se046a

### Inside Rear Panel View

**Table 3-4** Inside Rear Panel View

Reference Designator	Description	Qty	Part Number
B1	Fan	1	3160-4121
A20	SMI (Source Module Interface)	1	E8251-60072
A21	Rear-Panel Interface	1	E8251-60013
A22	Line Module	1	5064-5053
A32	10 MHz Crystal Oscillator (Option UNJ)	1	E8251-60071

**Figure 3-4** Inside Rear Panel View

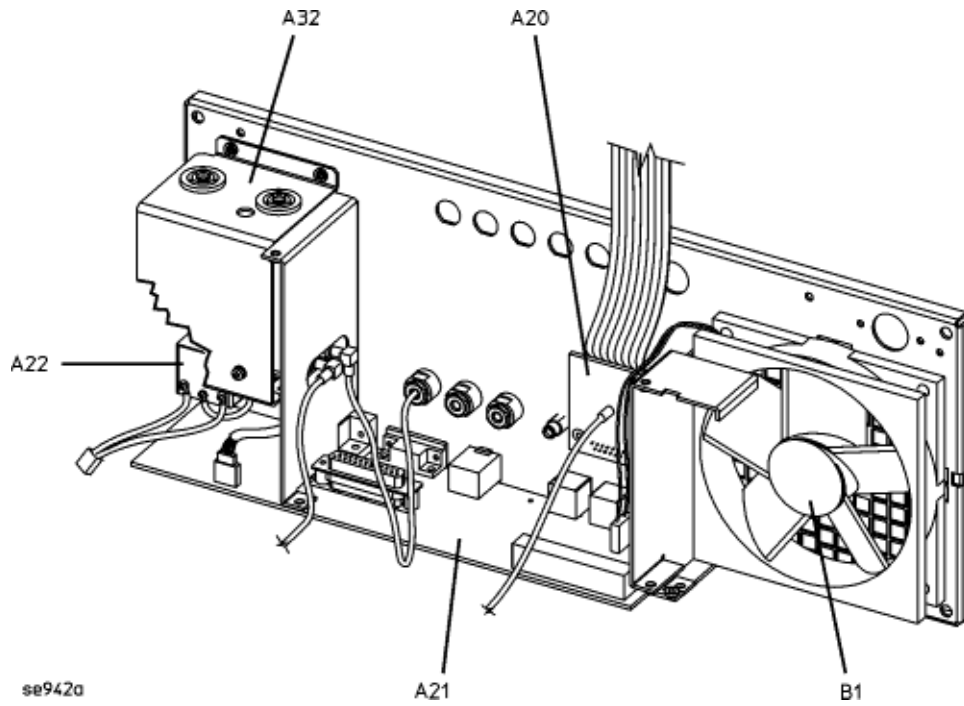

### Microcircuit Interface Deck Top View

**Table 3-5 Microcircuit Interface Deck Top View**

Reference Designator	Description	Qty	Part Number
AT1	115 dB Attenuator (Option 1E1)	1	E8251-60070
A23	Low Band Coupler/Detector	1	E8251-60021
A24	40 GHz High Band Coupler (E8244A and E8254A 250 kHz to 40 GHz Models Only)	1	0955-1136
	20 GHz High Band Coupler (E8241A and E8251A 250 kHz to 20 GHz Models Only) not shown	1	0955-0148
A25	40 GHz High Band Detector (E8244A and E8254A 250 kHz to 40 GHz Models Only)	1	08360-60059
	20 GHz High Band Detector (E8241A and E8251A 250 kHz to 20 GHz Models Only) not shown	1	08360-60058
A25B	High Band Detector Bias Board	1	08360-60091
A26	MID (Microcircuit Interface Deck)	1	E8251-60009
A27	40 GHz Doubler with Standard Power	1	5087-7063
	40 GHz Doubler with High Power (Option 1EA)	1	5087-7064

**Figure 3-5 Microcircuit Interface Deck Top View**

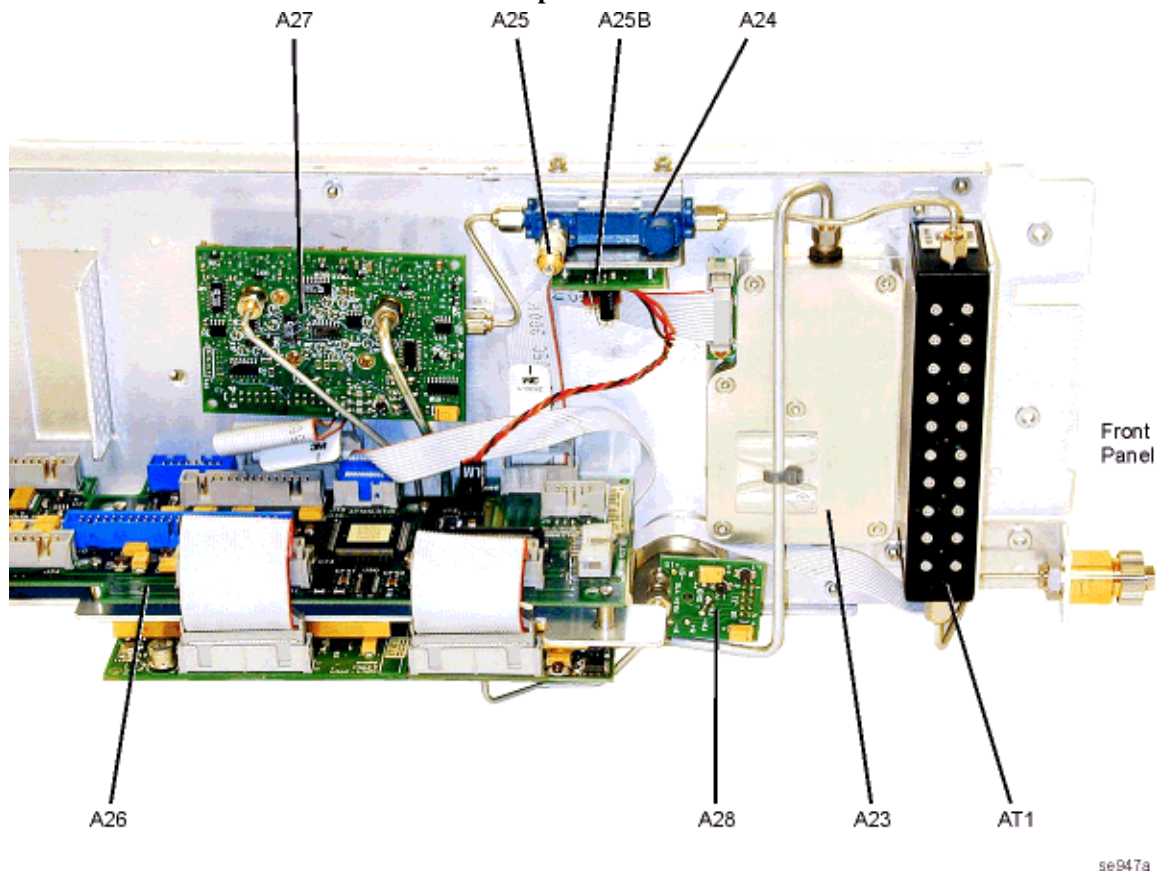

### MID Bottom View

**Table 3-6**                      **MID Bottom View**

<b>Reference Designator</b>	<b>Description</b>	<b>Qty</b>	<b>Part Number</b>
A28	YIG Oscillator	1	5087-7113
A29	20 GHz Doubler	1	5087-7058
A30	Modulator Filter with Standard Power	1	5087-7060
	Modulator Filter with High Power (Option 1EA)	1	5087-7061



Figure 3-6 MID Bottom View

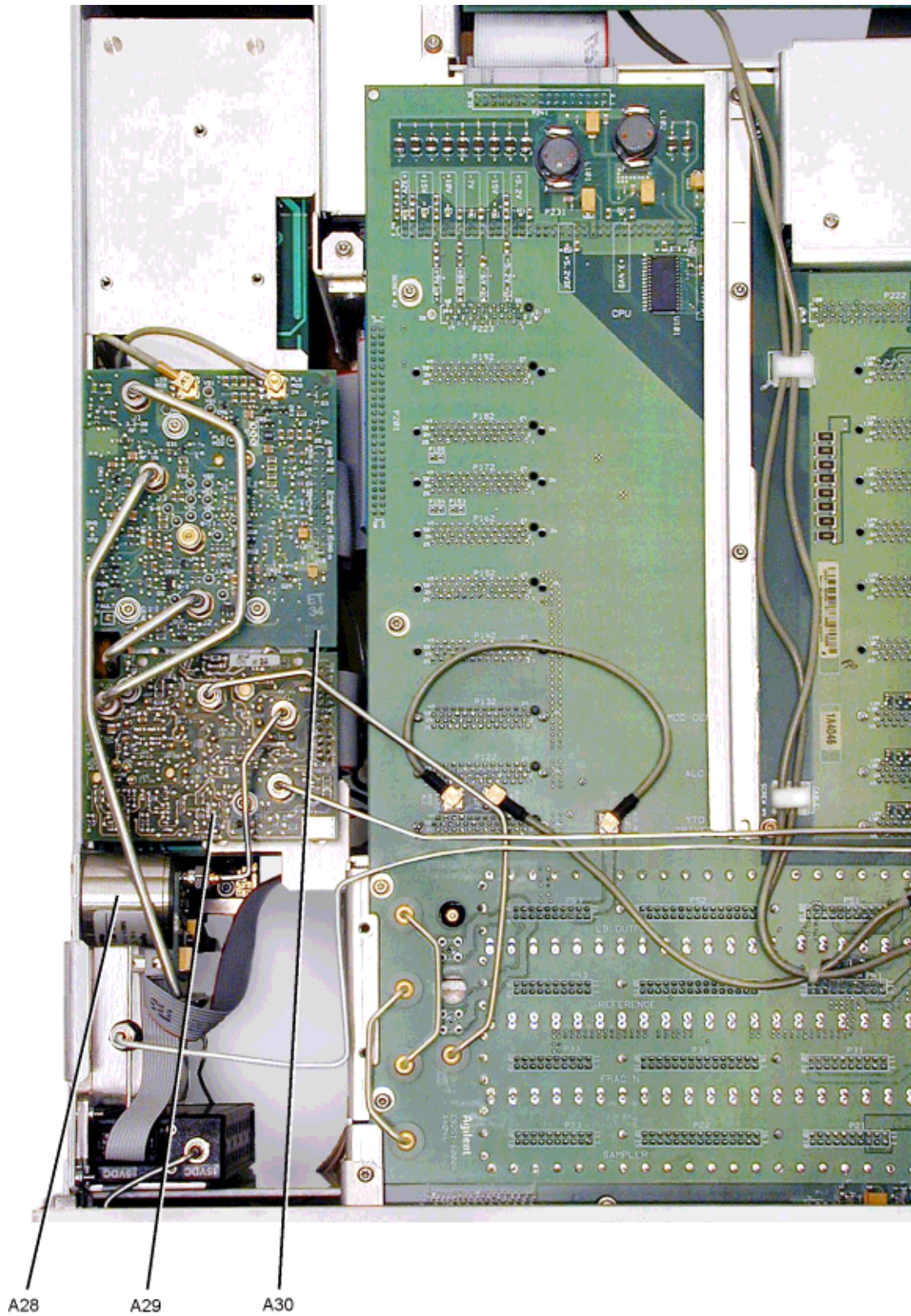

## Battery-Lithium

Table 3-7 Battery-Lithium

Reference Designator	Description	Qty	Part Number
A18BT1	Battery-Lithium	1	1420-0314

Figure 3-7 Battery-Lithium

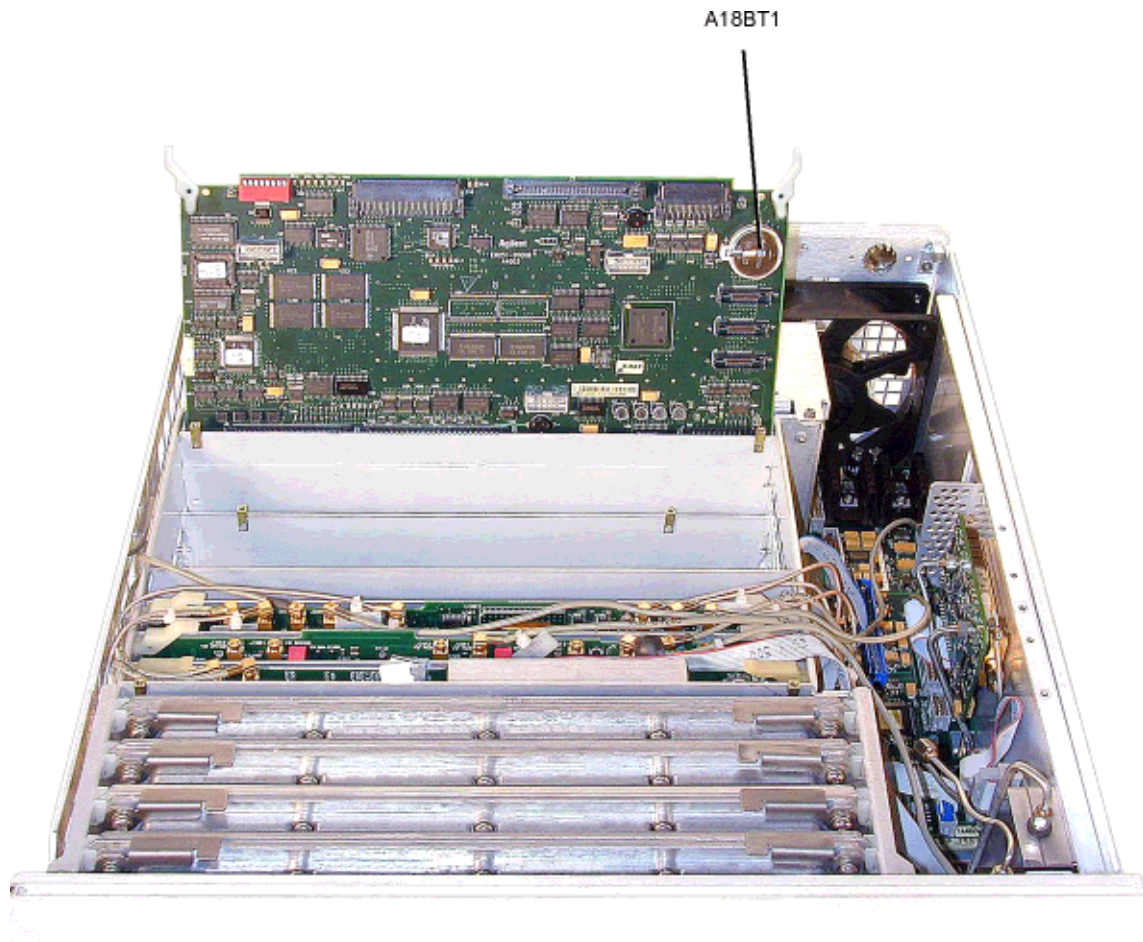

se057a

## Cables

This section lists part numbers for the cables in your signal generator.

- “Inside Front Panel View” on page 3-22
- “Main Chassis Top View” on page 3-24
- “Rear Panel View” on page 3-26
- “MID Top View (E8244A and E8254A Models Only)” on page 3-28
- “MID Top View (E8241A and E8251A Models Only)” on page 3-30
- “MID Bottom View” on page 3-32
- “Main Chassis Bottom View” on page 3-34

## Inside Front Panel View

**Table 3-8**                      **Inside Front Panel View**

Reference Designator	Description	Qty	Part Number
A4W1*	Wire Cable, A4 Inverter to P12 of A31 Motherboard	1	(part of A4)
A2DS1W1*	Wire Cable, A2DS1 to A4 Inverter	1	(part of A2)
A1W1*	Ribbon Cable, A1 Keyboard to P13 of A31 Motherboard	1	(part of A1)
W1	Flexible Cable, EXT 1 to J401 of A11 Pulse/Analog Modulation Generator	1	8121-0628
W2	Flexible Cable, EXT 2 to J402 of A11 Pulse/Analog Modulation Generator	1	8121-0628
W3	Flexible Cable, LF OUTPUT to J403 of A11 Pulse/Analog Modulation Generator	1	8121-0628
W4	Flexible Cable, ALC INPUT to J4 of A10 ALC	1	8121-0609
W5	Flexible Cable, PULSE/TRIGGER GATE INPUT to J201 of A11 Pulse/Analog Modulation Generator	1	8121-0625
W6	Flexible Cable, PULSE VIDEO OUT to J203 of A11 Pulse/Analog Modulation Generator	1	8121-0625
W7	Flexible Cable, PULSE SYNC OUT to J202 of A11 Pulse/Analog Modulation Generator	1	8121-0625
W8	Ribbon Cable, A3 Power Switch (DATA CABLE) to A2 Display	1	8121-0165
W9	Ribbon Cable, P1 of A3 Power Switch to P11 of A31 Motherboard	1	8121-0614

\*. This cable is not replaceable by itself. You must order the corresponding assembly.

Figure 3-8 Inside Front Panel View

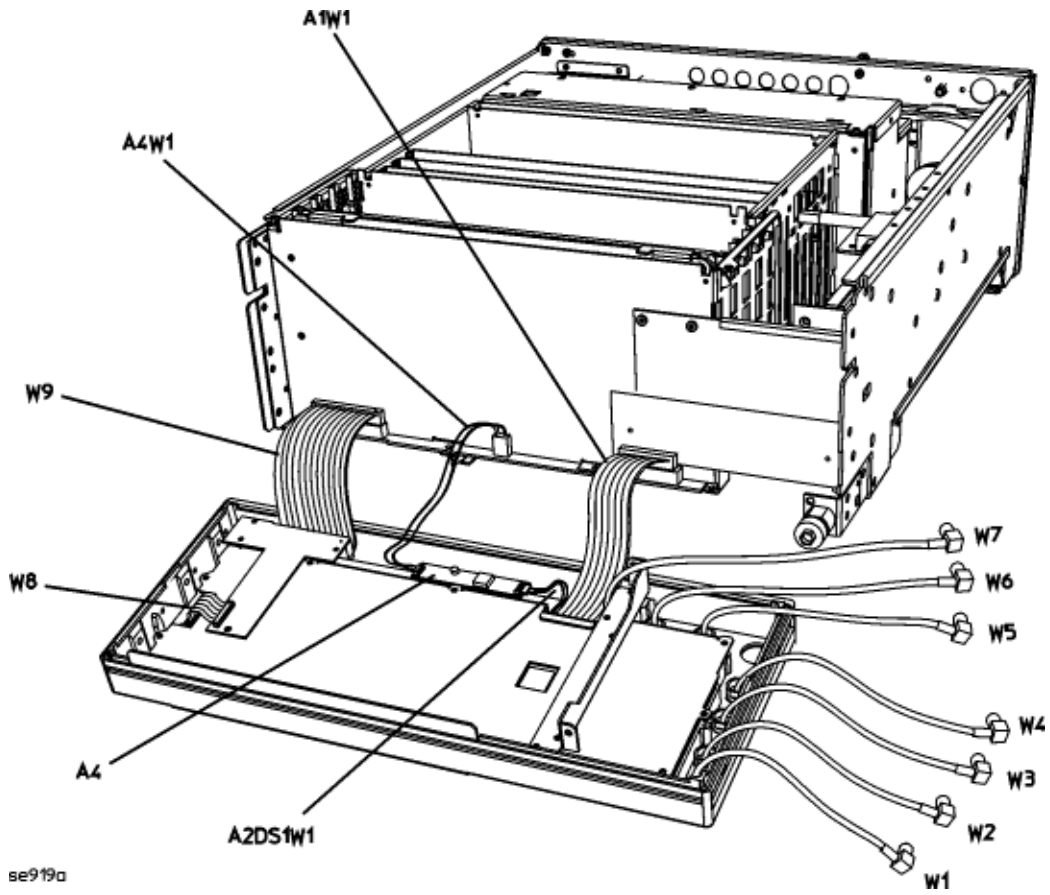

## Main Chassis Top View

**Table 3-9 Main Chassis Top View**

Reference Designator	Description	Qty	Part Number
W1	Flexible Cable, EXT 1 to J401 of A11 Pulse/Analog Modulation Generator	1	8121-0628
W2	Flexible Cable, EXT 2 to J402 of A11 Pulse/Analog Modulation Generator	1	8121-0628
W3	Flexible Cable, LF OUTPUT to J403 of A11 Pulse/Analog Modulation Generator	1	8121-0628
W4	Flexible Cable, ALC INPUT to J4 of A10 ALC	1	8121-0609
W5	Flexible Cable, PULSE/TRIGGER GATE INPUT to J201 of A11 Pulse/Analog Modulation Generator	1	8121-0625
W6	Flexible Cable, PULSE VIDEO OUT to J203 of A11 Pulse/Analog Modulation Generator	1	8121-0625
W7	Flexible Cable, PULSE SYNC OUT to J202 of A11 Pulse/Analog Modulation Generator	1	8121-0625
W10	Flexible Cable, J3 of A9 YIG Driver to J1031 of A31 Motherboard	1	8121-0621
W11	Flexible Cable, J4 of A9 YIG Driver to J1021 of A31 Motherboard	1	8121-0625
W12	Ribbon Cable, J5 of A9 YIG Driver to J1 of A28 YIG Oscillator	1	8121-0608
W13	Flexible Cable, J201 of A10 ALC to J6 of A30 Modulator Filter with Standard or High Power	1	8121-0624
W14	Flexible Cable, J5 of A10 ALC to A23 Low Band Coupler/Detector	1	8121-0627
W15	Flexible Cable, J3 of A10 ALC to A25 High Band Detector	1	8121-0607
W16	Flexible Cable, J204 of A11 Pulse/Analog Modulation Generator to A20 SMI	1	8121-0625
W17	Flexible Cable, J205 of A11 Pulse/Analog Modulation Generator to J7 of A30 Modulator Filter with Standard or High Power	1	8121-0626
W18	Ribbon Cable, J1 of A18 CPU to J3 of A21 Rear Panel	1	8121-0617
W19	Ribbon Cable, J2 of A18 CPU to J30 of A26 MID [Microcircuit Interface Deck]	1	8121-0619

Figure 3-9

Main Chassis Top View

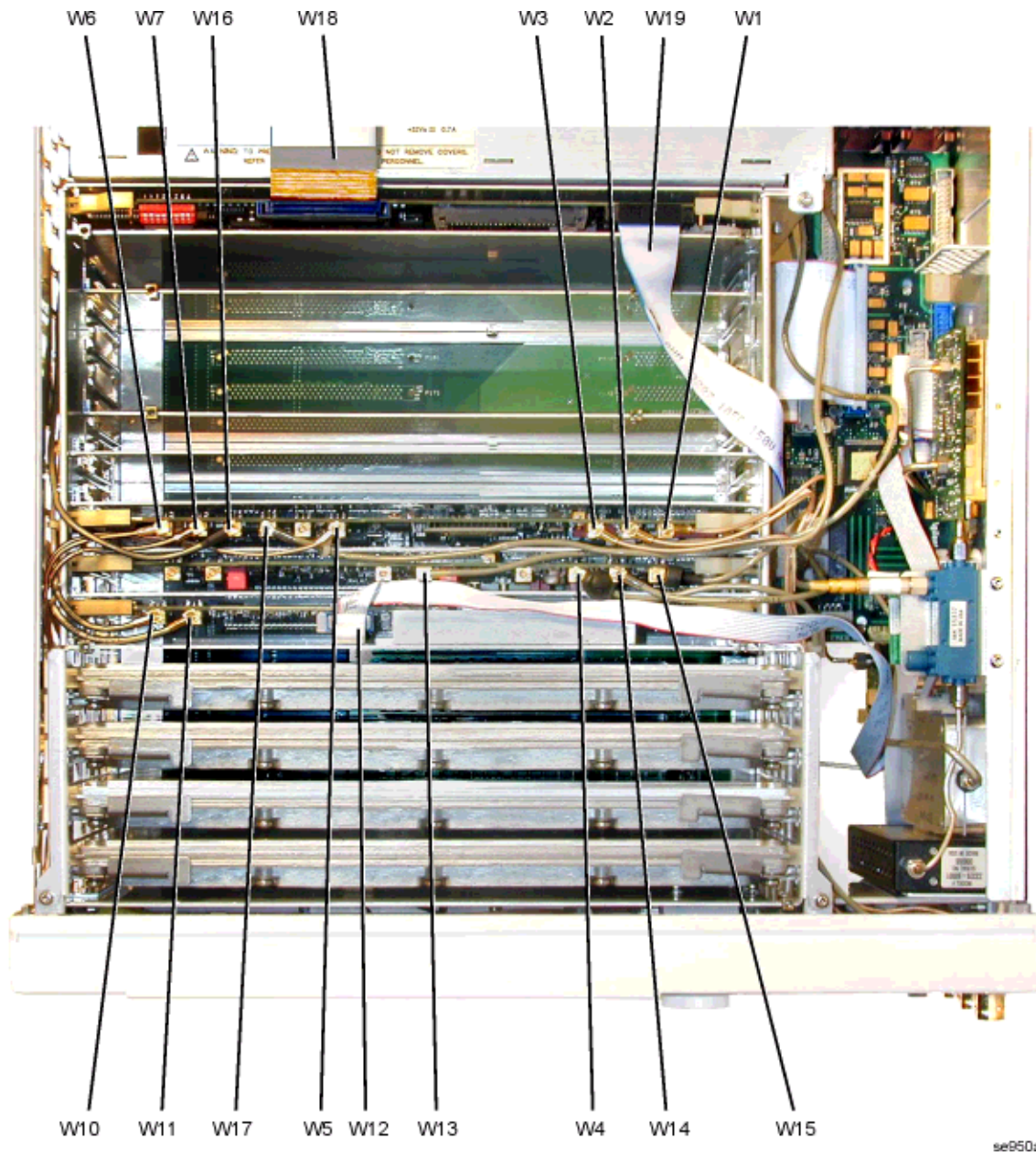

se950a

**Rear Panel View**

**Table 3-10 Rear Panel View**

Reference Designator	Description	Qty	Part Number
A22W1*	A22 Line Module to A19 Power Supply	1	(part of A22)
A22W2*	A22 Line Module to chassis ground post on rear-panel	1	(part of A22)
A32W1*	Wire Cable, A32 Crystal Oscillator to P2 of A21 Rear-Panel Interface Option UNJ	1	(part of A32)
B1W1*	Wire Cable, B1 Fan to P6 of A21 Rear-Panel Interface	1	(part of B1)
W20	Ribbon Cable, J1 of A20 SMI to J20 of A26 MID	1	8121-0677
W21	Flexible Cable, J1043 of A31 Motherboard to rear-panel (10 MHz OUT)	1	8121-0622
W22	Flexible Cable, J1042 of A31 Motherboard to rear-panel (10 MHz IN)	1	8121-0622
W23	Ribbon Cable, J2 of A21 Rear-Panel Interface to P241 of A31 Motherboard	1	8121-0611
W47	Flexible Cable, J2 of A32 Crystal Oscillator to Rear-Panel (10 MHz EFC) Option UNJ	1	8121-6839
W48	Flexible Cable, J1 of A32 Crystal Oscillator to J1041 of A31 Motherboard Option UNJ	1	8121-0621

\*. This cable is not replaceable by itself. You must order the corresponding assembly.



Figure 3-10

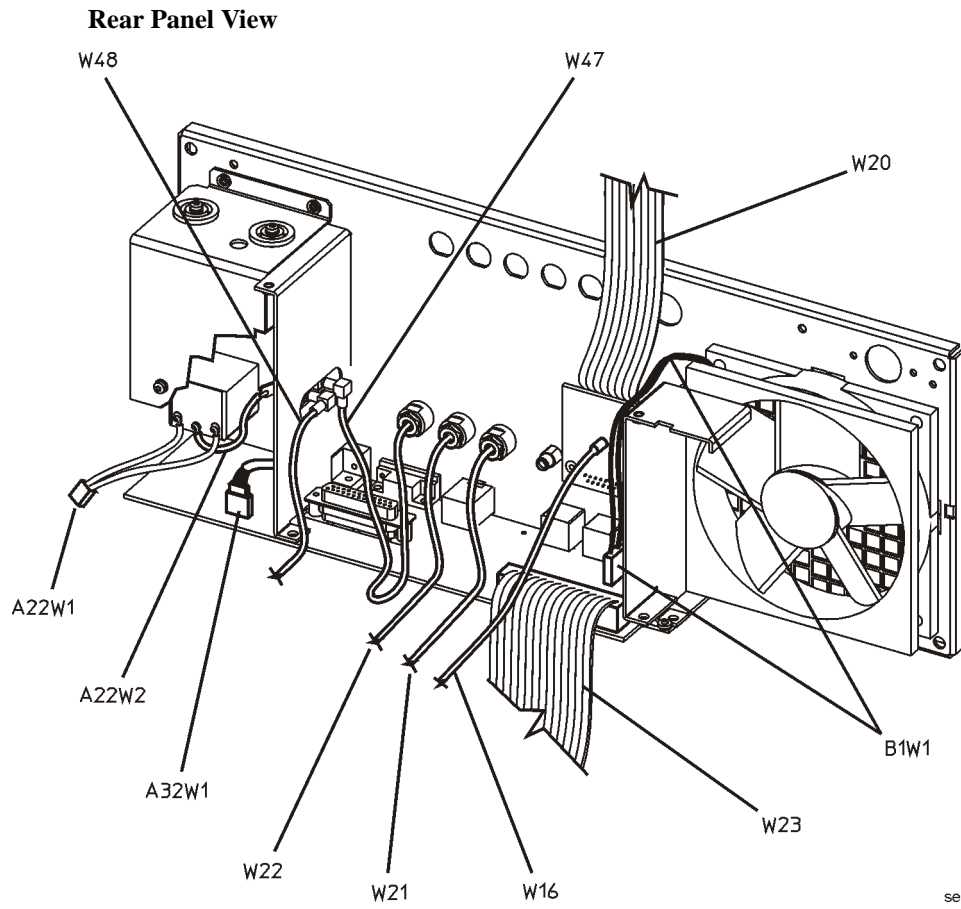

se943a

**MID Top View (E8244A and E8254A Models Only)**

**Table 3-11 MID Top View (E8244A and E8254A Models Only)**

Reference Designator	Description	Qty	Part Number
A25BW1*	Wire Cable, A25B High Band Detector Bias board to J12 of A26 MID	1	(part of A25)
W24	Semi-Rigid Cable, A24 High Band Coupler output to AT1 input Option 1E1	1	E8251-20025
W25	Semi-Rigid Cable, AT1 output to 2.4 mm RF Output adapter Option 1E1	1	E8251-20028
W26	Semi-Rigid Cable, A24 High Band Coupler output to 2.4mm RF Output adapter (models without Option 1E1) not shown	1	E8251-20035
W27	Semi-Rigid Cable, J2 of A23 Low Band Coupler/Detector to J3 of A30 Modulator Filter with Standard or High Power	1	E8251-20031
W28	Ribbon Cable, J100 of A23 Low Band Coupler/Detector to J15 of A26 MID	1	8121-0616
W29	Ribbon Cable, J10 of A27 40 GHz Doubler to J33 of A26 MID	1	8121-0613
W30	Semi-Rigid Cable, J2 of A27 40 GHz Doubler output to A24 High Band Coupler input	1	E8251-20024
W31	Semi-Rigid Cable, J3 of A27 40 GHz Doubler to J2 of A30 Modulator Filter with Standard or High Power	1	E8251-20023
W32	Semi-Rigid Cable, J1 of A27 40 GHz Doubler to J4 of A30 Modulator Filter with Standard or High Power	1	E8251-20022
W33	Ribbon Cable, J32 of A26 MID to J10 of A29 20 GHz Doubler	1	8121-0613
W34	Ribbon Cable, J31 of A26 MID to J10 of A30 Modulator Filter with Standard or High Power	1	8121-0613
W35	Ribbon Cable, J10 of A26 MID to P201 of A31 Motherboard	1	8121-0615

\*. This cable is not replaceable by itself. You must order the corresponding assembly.

Figure 3-11 MID Top View (E8244A and E8254A Models Only)

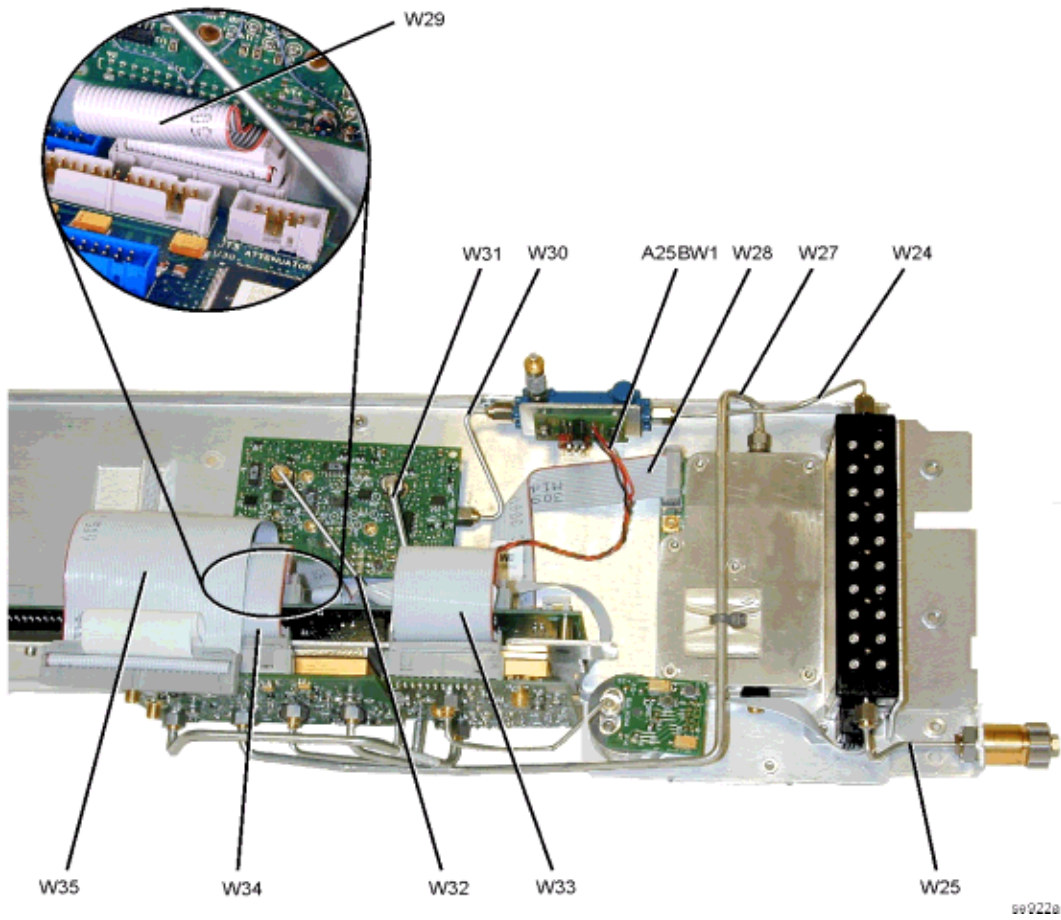

**MID Top View (E8241A and E8251A Models Only)**

**Table 3-12 MID Top View (E8241A and E8251A Models Only)**

Reference Designator	Description	Qty	Part Number
A25BW1*	Wire Cable, A25B High Band Detector Bias Board to J12 of A26 MID	1	(part of A25)
W24	Semi-Rigid Cable, A24 20 GHz High Band Coupler Output to AT1 Input Option 1E1	1	E8251-20026
W25	Semi-Rigid Cable, AT1 output to APC 3.5 RF Output Adapter Option 1E1	1	E8251-20027
W26	Semi-Rigid Cable, A24 20 GHz High Band Coupler Output to APC 3.5 RF Output Adapter (models without Option 1E1) not shown	1	E8251-20034
W27	Semi-Rigid Cable, A23 Low Band Coupler/Detector Input to J3 of A30 Modulator Filter with Standard or High Power	1	E8251-20031
W28	Ribbon Cable, J100 of A23 Low Band Coupler/Detector to J15 of A26 MID	1	8121-0616
W48	Semi rigid Cable, A24 20 GHz High Band Coupler to J2 of A30 Modulator Filter with Standard or High Power	1	E8251-20021
W33	Ribbon Cable, J32 of A26 MID to J10 of A29 20 GHz Doubler	1	8121-0613
W34	Ribbon Cable, J31 of A26 MID to J10 of A30 Modulator Filter with Standard or High Power	1	8121-0613
W35	Ribbon Cable, J10 of A26 MID to P201 of A31 Motherboard	1	8121-0615
W36	Ribbon Cable, AT1 to J13 of MID Option 1E1	1	5062-6646
Load	Load 50 ohm, J4 of A30 Modulation Filter	1	1810-0118

\*. This cable is not replaceable by itself. You must order the corresponding assembly.

Figure 3-12 MID Top View (E8241A and E8251A Models Only)

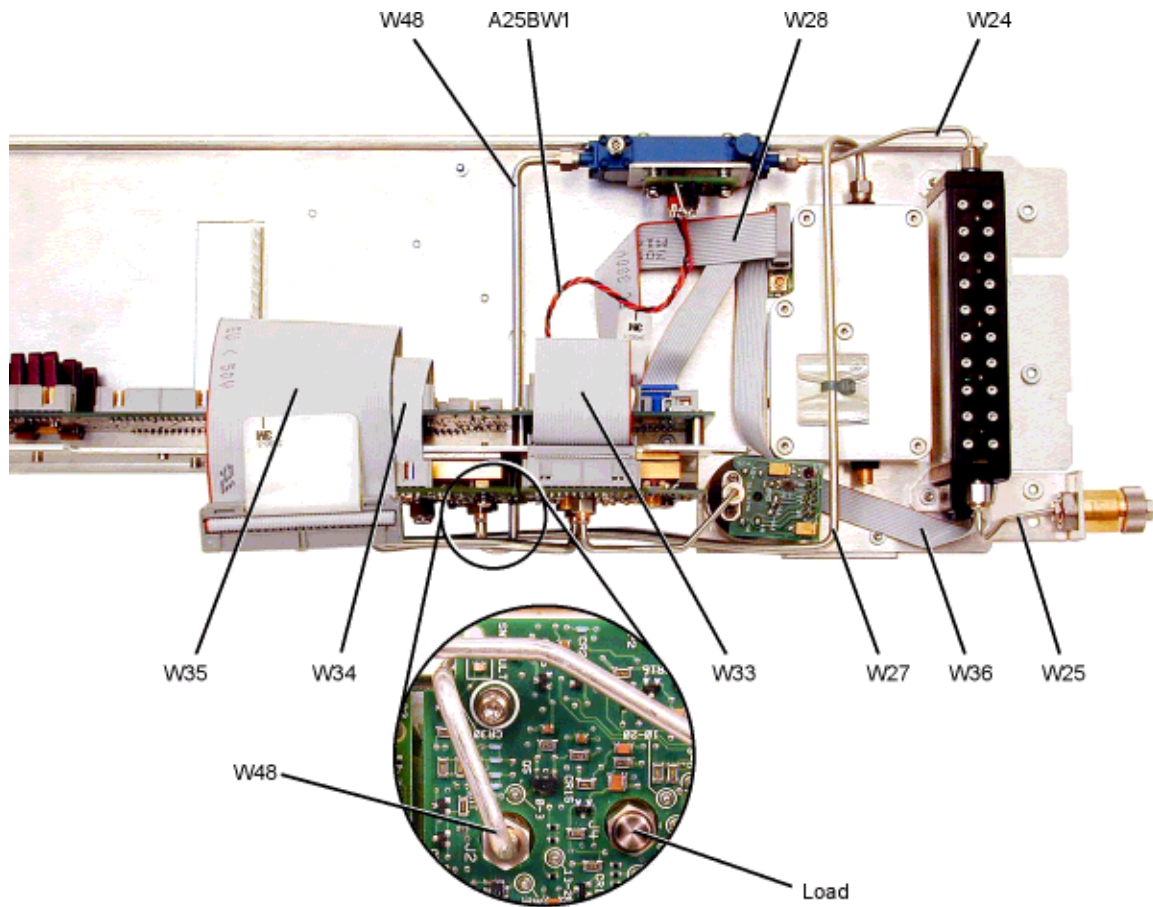

se951a

## MID Bottom View

**Table 3-13**                    **MID Bottom View**

<b>Reference Designator</b>	<b>Description</b>	<b>Qty</b>	<b>Part Number</b>
W36	Ribbon Cable, AT1 to J13 of A26 MID Option 1E1	1	5062-6646
W37	Semi-Rigid Cable, A23 Low Band Coupler/Detector to A31 Motherboard (Output)	1	E8251-20020
W38	Semi-Rigid Cable, A28 YIG Oscillator to J1 of A29 20 GHz Doubler	1	E8251-20014
W39	Semi-Rigid Cable, J4 of A29 20 GHz Doubler to A31 Motherboard (Sampler)	1	E8251-20015
W40	Semi-Rigid Cable, J3 of A29 20 GHz Doubler to A31 Motherboard (Frac-N)	1	E8251-20016
W41	Semi-Rigid Cable, J2 of A29 20 GHz Doubler to J1 of A30 Modulation Filter	1	E8251-20017

Figure 3-13 MID Bottom View

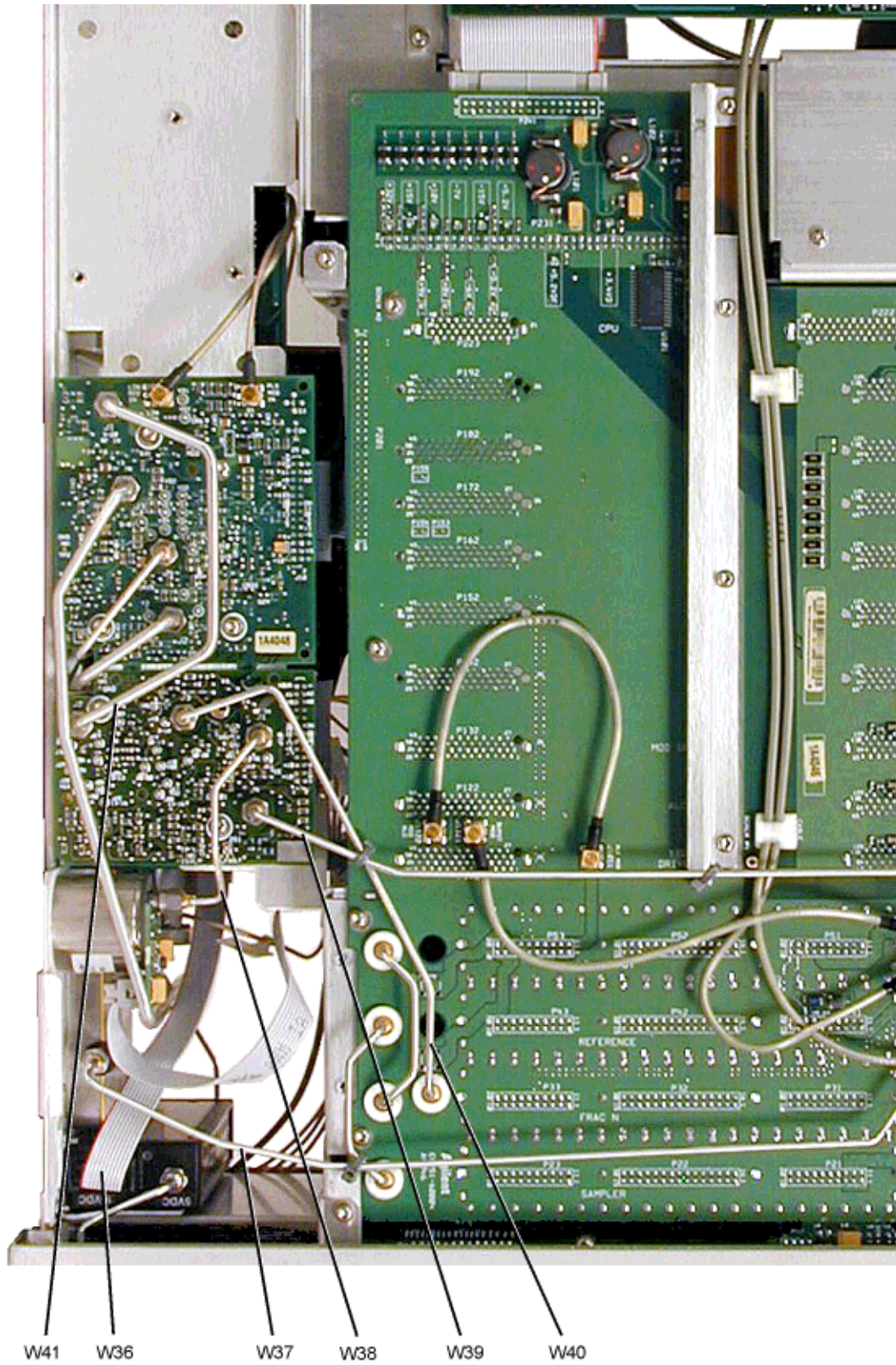

se952a

## Main Chassis Bottom View

**Table 3-14**                      **Main Chassis Bottom View**

<b>Reference Designator</b>	<b>Description</b>	<b>Qty</b>	<b>Part Number</b>
W42	Semi-Rigid Cable, A31 Motherboard (Sampler) to Motherboard (Reference)	1	E8251-20030
W43	Semi-Rigid Cable, A31 Motherboard (Frac-N) to A31 Motherboard (Output)	1	E8251-20030
W44	Flexible Cable, J1051 of A31 Motherboard to J1122 of A31 Motherboard	1	8121-0620
W45	Flexible Cable, J1055 of A31 Motherboard to J1121 of A31 Motherboard	1	8121-0620
W46	Semi-Rigid Cable, A31 Motherboard (Sampler) to A31 Motherboard (Frac-N)	1	E8251-20029



Figure 3-14 Main Chassis Bottom View

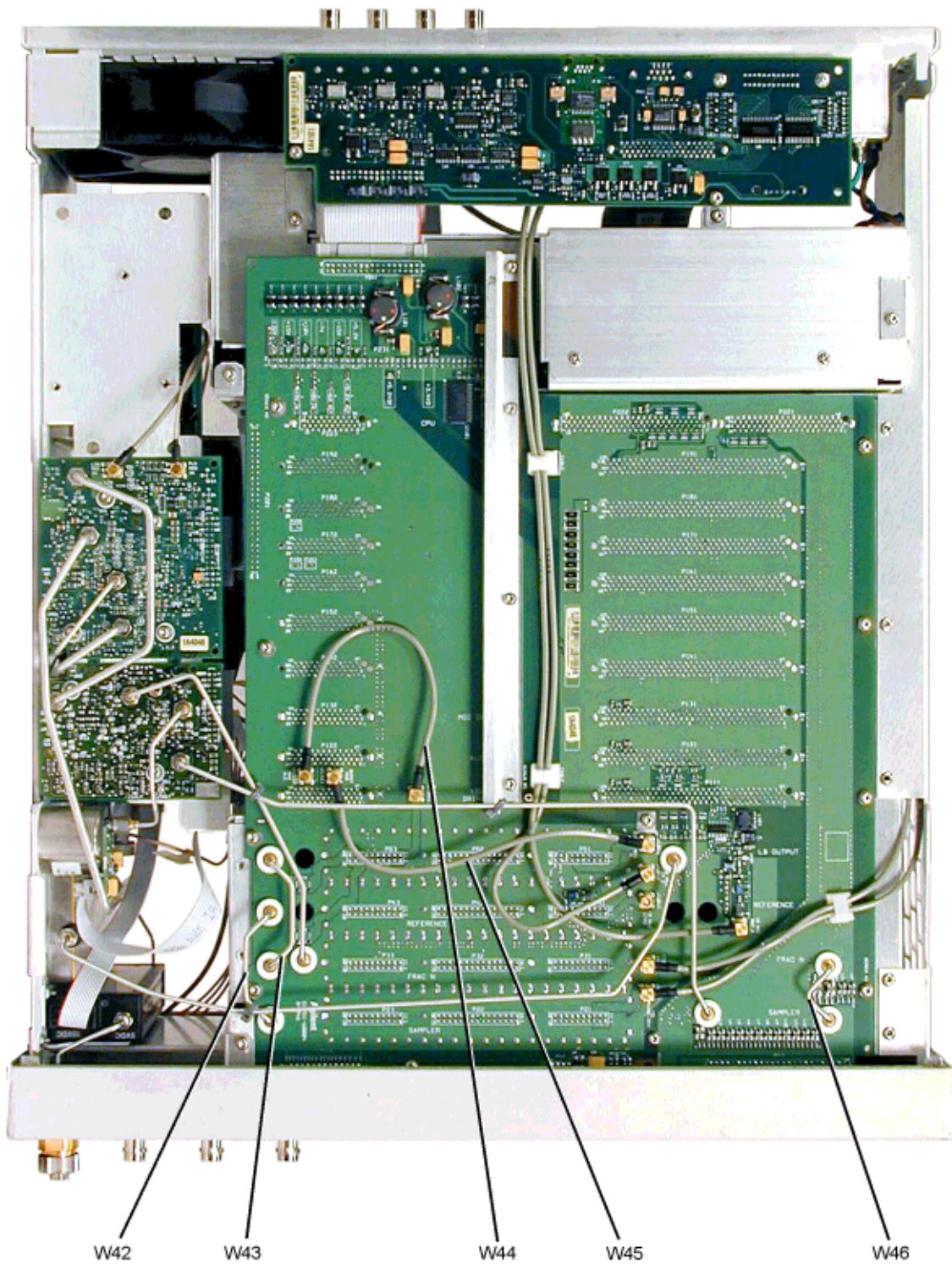

se953a

## Hardware and Other Instrument Parts

This section lists part numbers for hardware and other instrument parts in your signal generator.

- “Front Panel View” on page 3-37
- “Disassembled Front Panel View” on page 3-38
- “Disassembled Rear Panel View” on page 3-41
- “Disassembled A32 10 MHz Crystal Oscillator (Option UNJ)” on page 3-43
- “Disassembled Rear Panel View” on page 3-41
- “Disassembled AT1 115 dB Attenuator View (Option 1E1)” on page 3-44
- “Disassembled A29 20 GHz Coupler/Detector (E8241A and E8251A Models Only)” on page 3-45
- “Disassembled A24 High Band Coupler and A25 High Band Detector (E8244A and E8254A Models Only)” on page 3-46
- “Microcircuit Interface Deck Top View” on page 3-47
- “Main Chassis and MID Bottom View” on page 3-49
- “2.4 mm RF Output Connector (E8244A and E8254A Models Only)” on page 3-51
- “APC 3.5 RF Output Connector (E8241A and E8251A Models Only)” on page 3-52
- “Type-N RF Output Connector (E8241A and E8251A with Option 1ED Models Only)” on page 3-53
- “Main Chassis with Inside Cover and Right-Side Support Wall” on page 3-54
- “Outer and Inner Instrument Covers and Associated Parts” on page 3-55

## Front Panel View

**Table 3-15 Front Panel View**

Item No.	Description	Qty	Part Number
1	Small Overlay	1	E8251-80011
2	Nameplate - E8241A 250 kHz - 20 GHz CW	1	E8251-80010
	Nameplate - E8244A 250 kHz - 20 GHz Analog	1	E8251-80011
	Nameplate - E8251A 250 kHz - 40 GHz CW	1	E8251-80012
	Nameplate - E8254A 250 kHz - 40 GHz Analog	1	E8251-80013
3	RPG Knob	1	E4400-40003
4	Large Keypad Overlay (E8251A and E8254A Analog Models Only)	1	E8251-80001
	Large Keypad Overlay (E8241A and E8244A CW Models Only)	1	E8251-80008
5	Nut-Hex 15/32-32	7	2950-0035
6	Washer-Wavy .490ID	7	3050-1919
7	Washer-Shoulder	2	00310-48801
8	Bottom Overlay (E8251A and E8254A Analog Models Only)	1	E8251-80003
	Bottom Overlay (E8241A and E8244A CW Models Only)	1	E8251-80009

**Figure 3-15 Front Panel View**

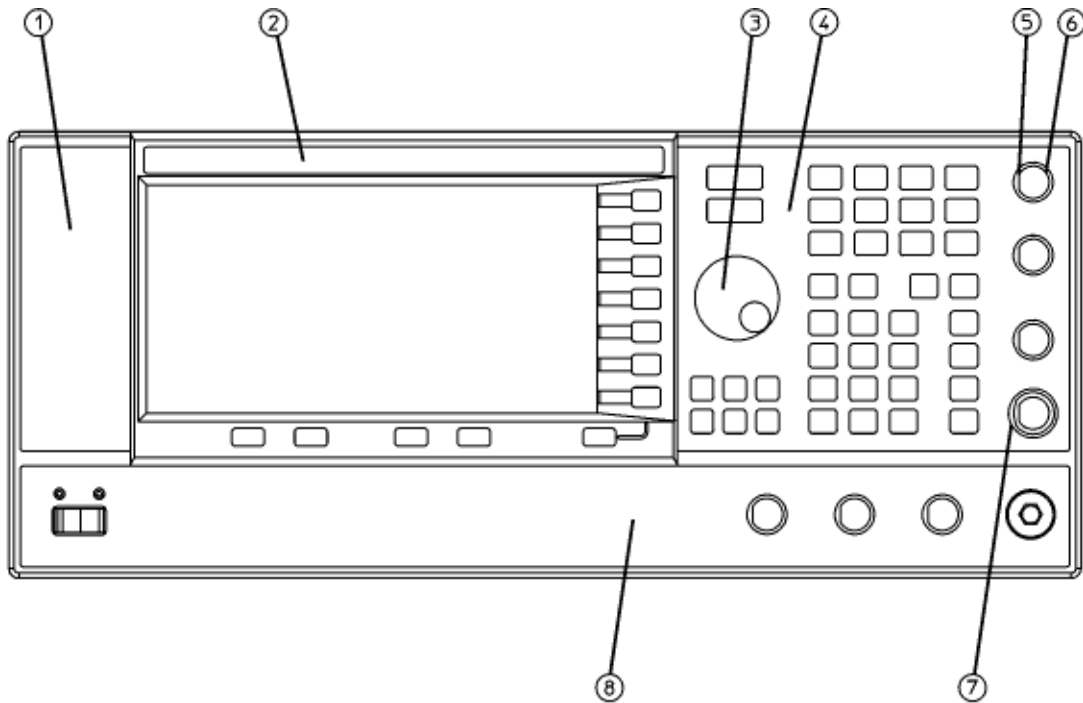

se939a

**Disassembled Front Panel View**

**Table 3-16 Disassembled Front Panel View**

Item No.	Description	Qty	Part Number
1	Front Panel Frame	1	E8251-20102
2	Gasket RFI Round Mesh .125 inch	1	8160-0660
3	Gasket RFI Round Mesh .062 inch	1	8160-0723
4	Velcro Attachment	1	0510-1303
5	Glass Filter 70% Xmt	1	4330-1711
6	Rubber Keypad CW (E8241A and E8244A Models Only)	1	E8251-40009
	Rubber Keypad Analog (E8251A and E8254A Models Only)	1	E8251-40006
7	Bracket Filter	1	E4400-00009
8	Screw-Machine M3.0 x 08 FL-TX	14	0515-1227
9	Cable Retainer Clip	3	1400-2293
10	Sub Panel	1	E8251-00009
11	Screw-Machine M3.0 x 06 CW-PN-TX	17	0515-0372
12	Screw-Machine M3.0 x 08 FL-TX	1	0515-1035

Figure 3-16 Disassembled Front Panel View

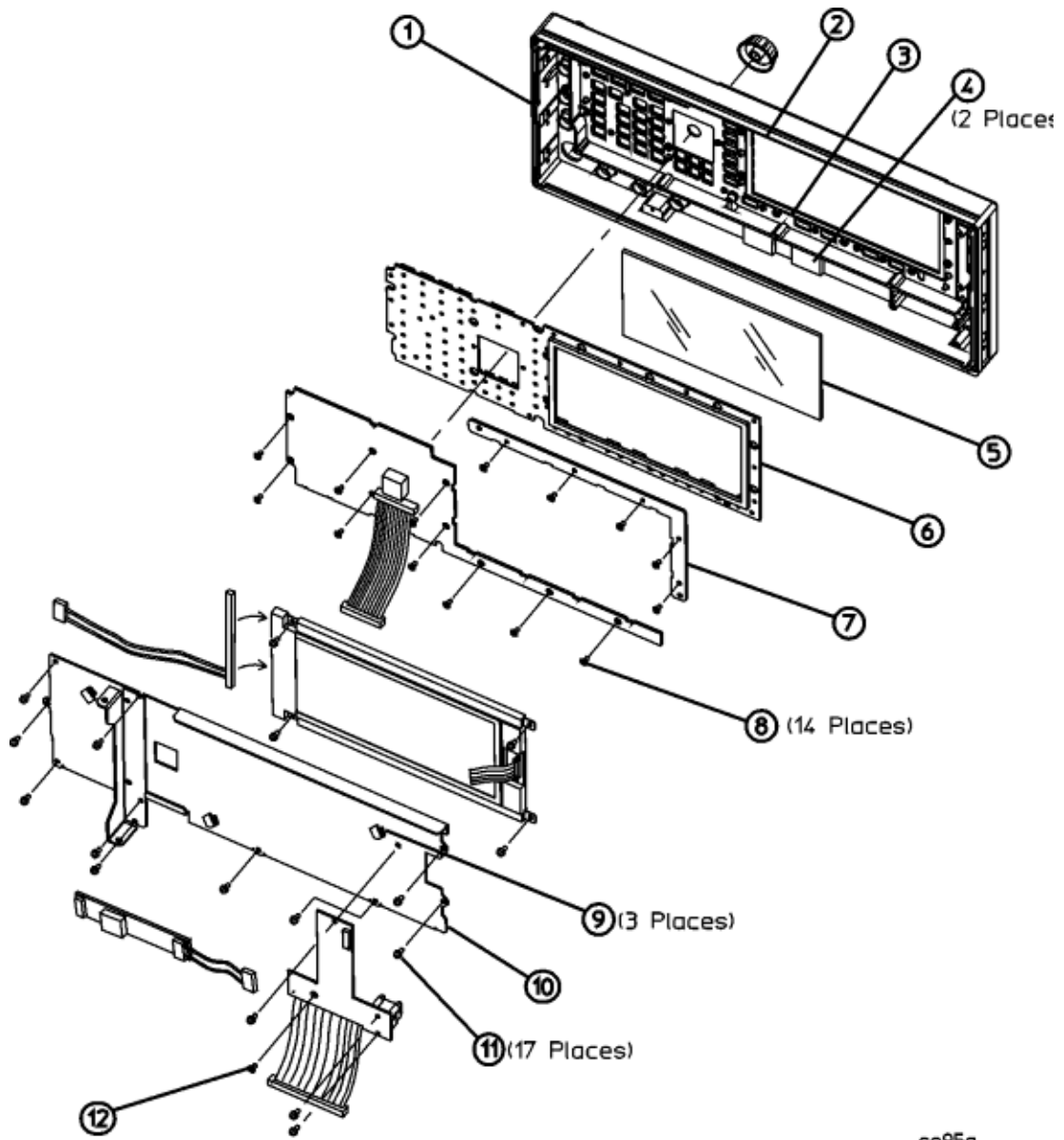

se95a

**Disassembled Rear Panel View**

**Table 3-17 Disassembled Rear Panel View**

Item No.	Description	Qty	Part Number
1	Rear Panel	1	E8251-00005
2	Screw-Machine M3.0 8 CW-PN-TX (mounting screws for rear-panel and rear struts)	10	0515-0372
3	Screw-Machine M3.0 14CW-PN-TX (screw to mount B1 fan to rear-panel)	4	0515-0665
4	Beveled Washer (fan)	4	3050-1628
5	Grommet (fan)	4	0400-0356
6	Nut-Hex 1/2-28 (4 BNC connectors on rear-panel board)	4	2950-0054
7	Washer Lock .505ID (4 BNC connectors on rear-panel)	4	2190-0068
8	Nut-Hex 15/32-32 (10 MHz In/Out BNC connectors)	2	2950-0035
9	Washer .490ID (10 MHz In/Out BNC connectors)	2	3050-1919
10	Rear-Panel RF Output Hole Plug (models without Option 1EM)	1	6960-0003
11	Standoff Screw-Hex .321I 4-40ss (Auxiliary Interface and SMI)	2	0380-2079
12	Split Lock Washer .115ID 4 (Auxiliary Interface and SMI)	2	2190-0003
13	Standoff Screw-Hex .327 6-32 (GPIB interface)	4	0380-0644
14	Split Lock Washer .194ID 10 (GPIB interface)	2	2190-0577
15	Screw-Machine M3.0 8 FL-TX (line module)	2	0515-1035
16	Right Rear Strut	1	E8251-00006
17	Left Rear Strut	1	E8251-00015

Figure 3-17 Disassembled Rear Panel View

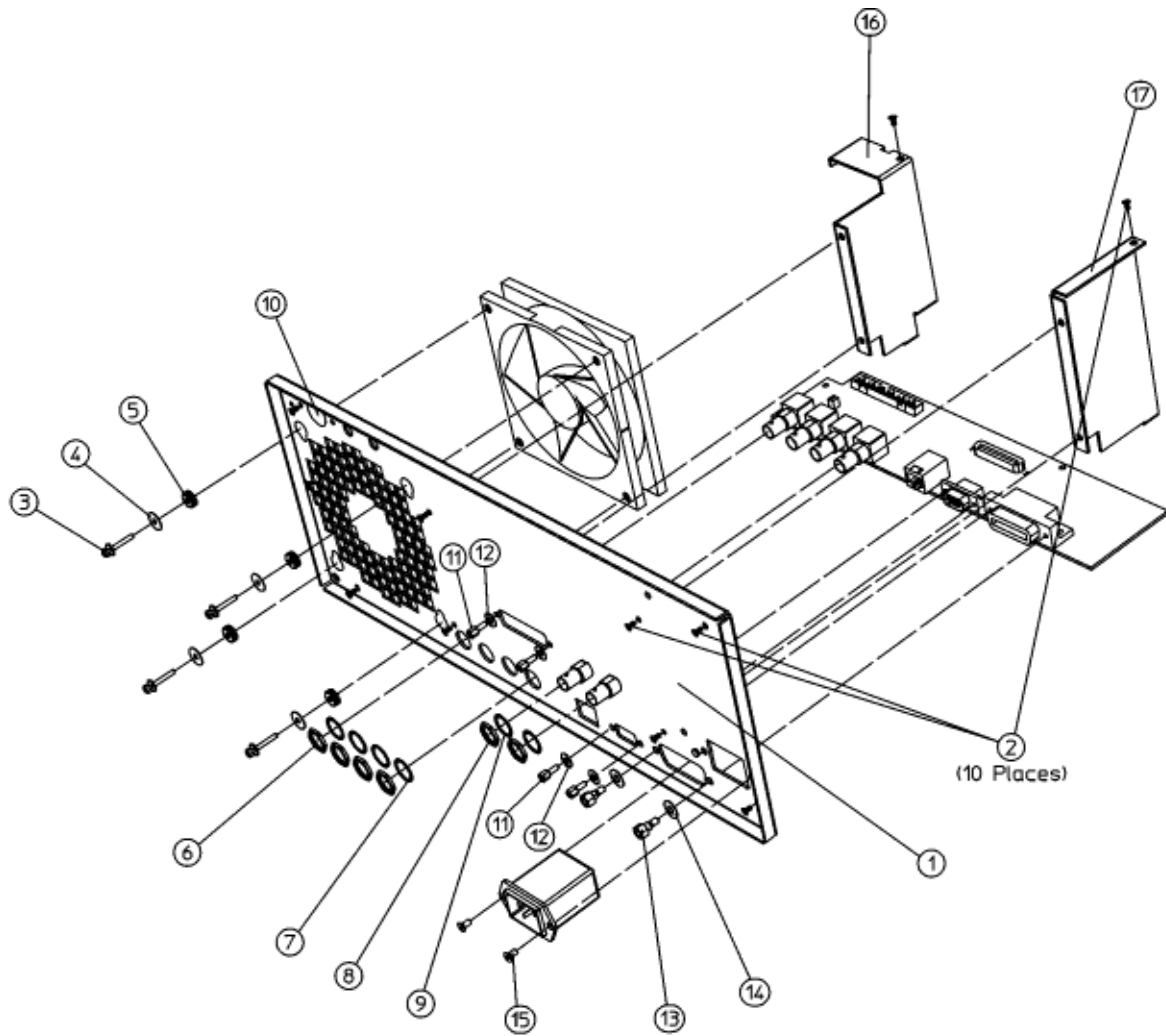

se915a

**Disassembled A32 10 MHz Crystal Oscillator (Option UNJ)**

**Table 3-18 Disassembled A32 10 MHz Crystal Oscillator (Option UNJ)**

Item No.	Description	Qty	Part Number
1	C-Bracket	1	E8251-00040
2	Shock Mount	3	1520-0205
3	Flathead Washer	3	3050-0105
4	Screw-Machine 4.0 x 40 .250	3	2200-0103
5	L-Bracket	1	E8251-00041
6	Screw-Machine M3.0 x 8 CW-PN-TX	2	0515-0372
7	Nut-Hex M3.0 (line module ground)	1	0535-0031
8	Screw-Machine M3.0 x 8 CW-PN-TX	3	0515-0372

**Figure 3-18 Disassembled A32 10 MHz Crystal Oscillator (Option UNJ)**

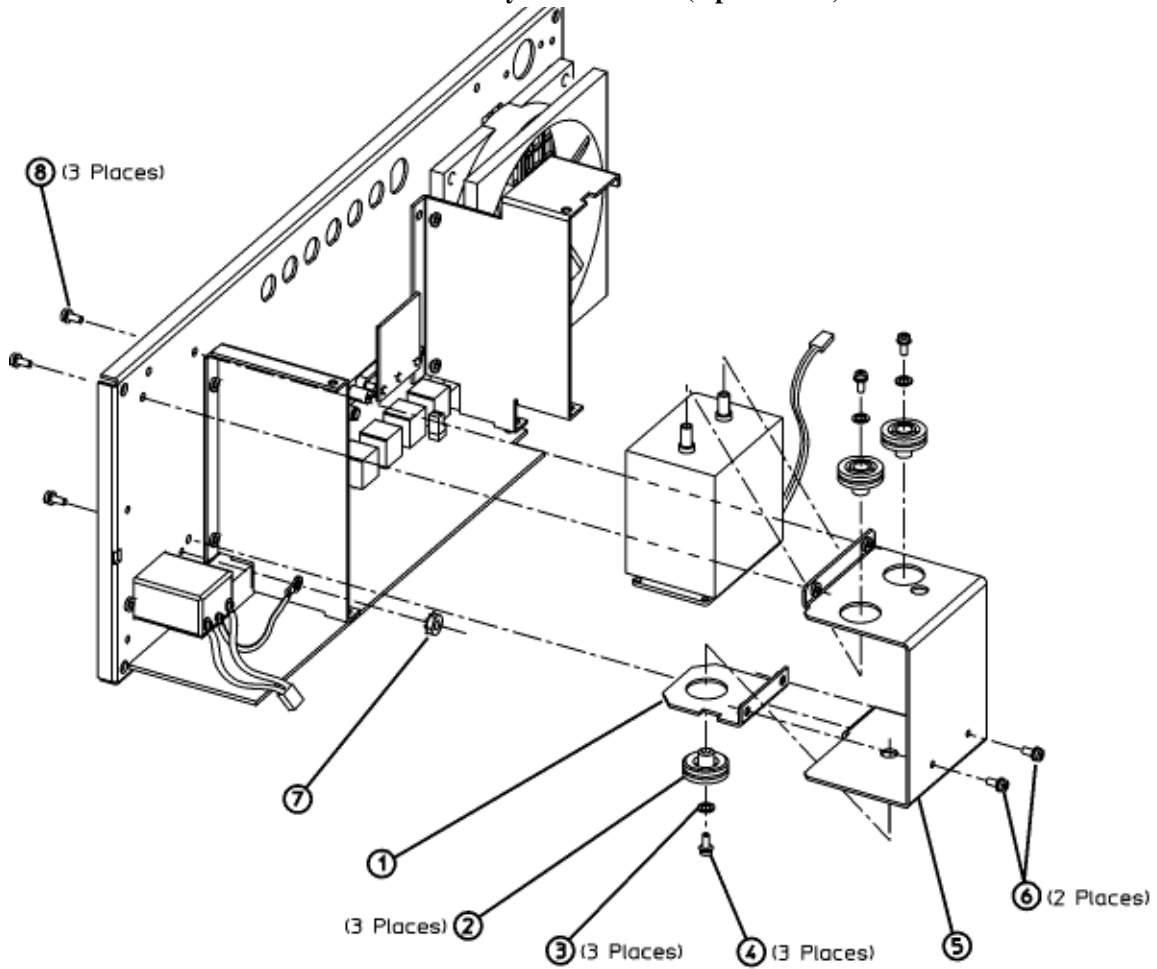



**Disassembled AT1 115 dB Attenuator View (Option 1E1)**

**Table 3-19 Disassembled AT1 115 dB Attenuator View (Option 1E1)**

Reference Designator	Description	Qty	Part Number
1	Bracket	1	E8251-00038
2	Screw-Machine M3.0 x 8 FL-TX	4	0515-1035

**Figure 3-19 Disassembled AT1 115 dB Attenuator View (Option 1E1)**

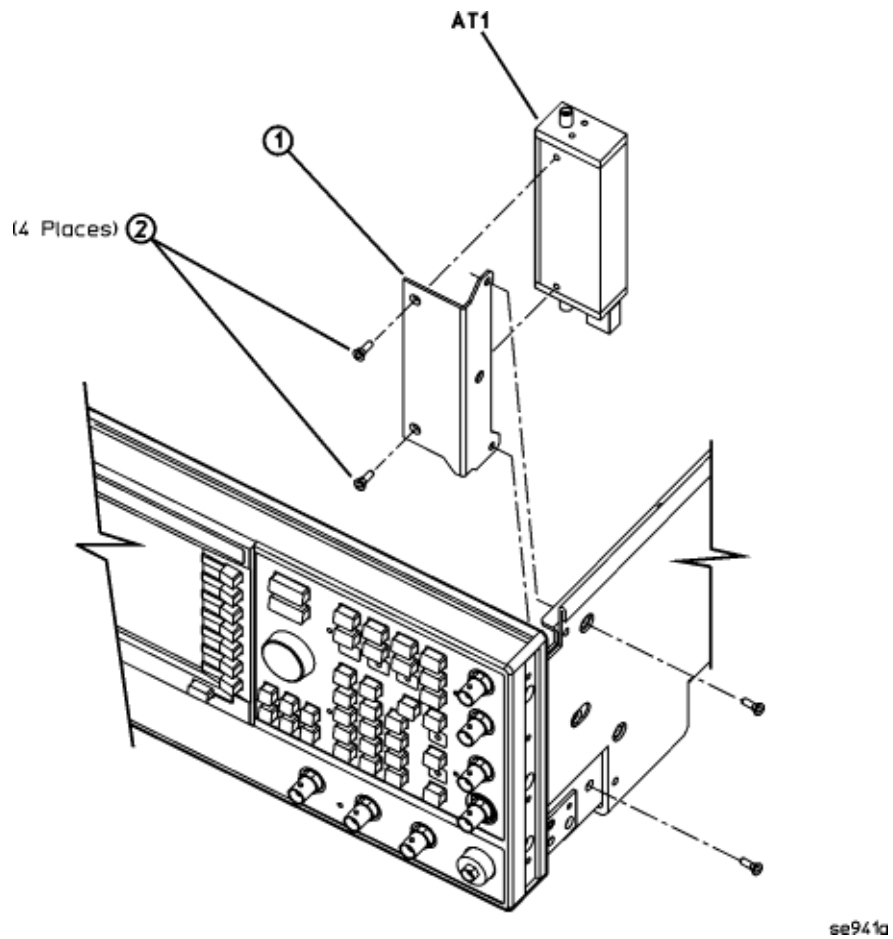

**Disassembled A29 20 GHz Coupler/Detector (E8241A and E8251A Models Only)**

**Table 3-20 Disassembled A29 20 GHz Coupler/Detector (E8241A and E82541 Models Only)**

Item No.	Description	Qty	Part Number
1	Coupler Bracket	1	E8251-00039
2	Washer Lock M2.0	2	2190-0654
3	Screw-Machine SM 256 .250 PN-PN	2	0520-0128
4	Screw-Machine M3.0 x 8 FL-TX	2	0510-1035
5	Screw-Machine M3.0 x 8 CW-PN-TX	2	0515-0372

**Figure 3-20 Disassembled A29 20 GHz Coupler/Detector (E8241A and E82541 Models Only)**

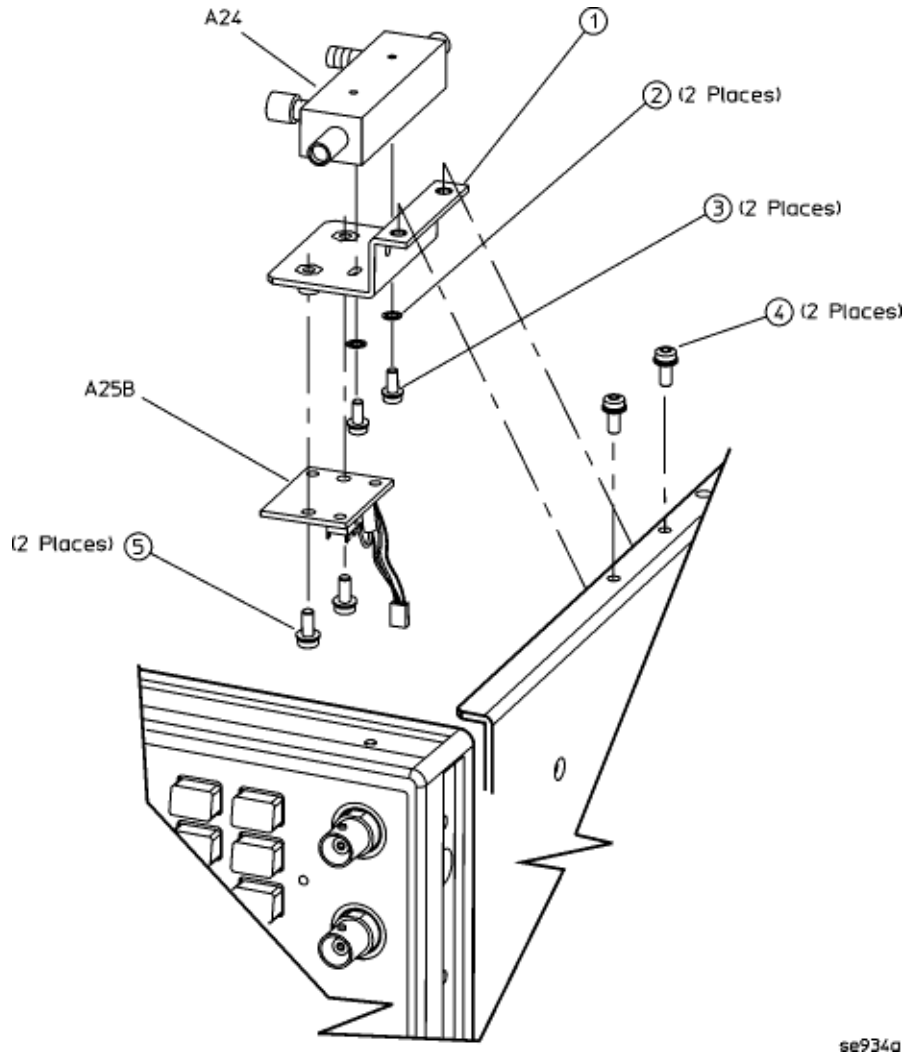

se934a

**Disassembled A24 High Band Coupler and A25 High Band Detector  
(E8244A and E8254A Models Only)**

**Table 3-21 Disassembled A24 High Band Coupler and A25 High Band Detector  
(E8244A and E8254A Models Only)**

Item No.	Description	Qty	Part Number
1	Coupler Bracket	1	E8251-00039
2	Washer Lock M2.5	2	2190-0583
3	Screw-Machine M4.0 x .312 PN-PN (E8244A and E8254A Models Only)	2	2200-0141
4	Screw-Machine M3.0 x 8 FL-TX	2	0510-1035
5	Screw-Machine M3.0 x 8 CW-PN-TX	2	0515-0372

**Figure 3-21 Disassembled A24 High Band Coupler and A25 High Band Detector  
(E8244A and E8254A Models Only)**

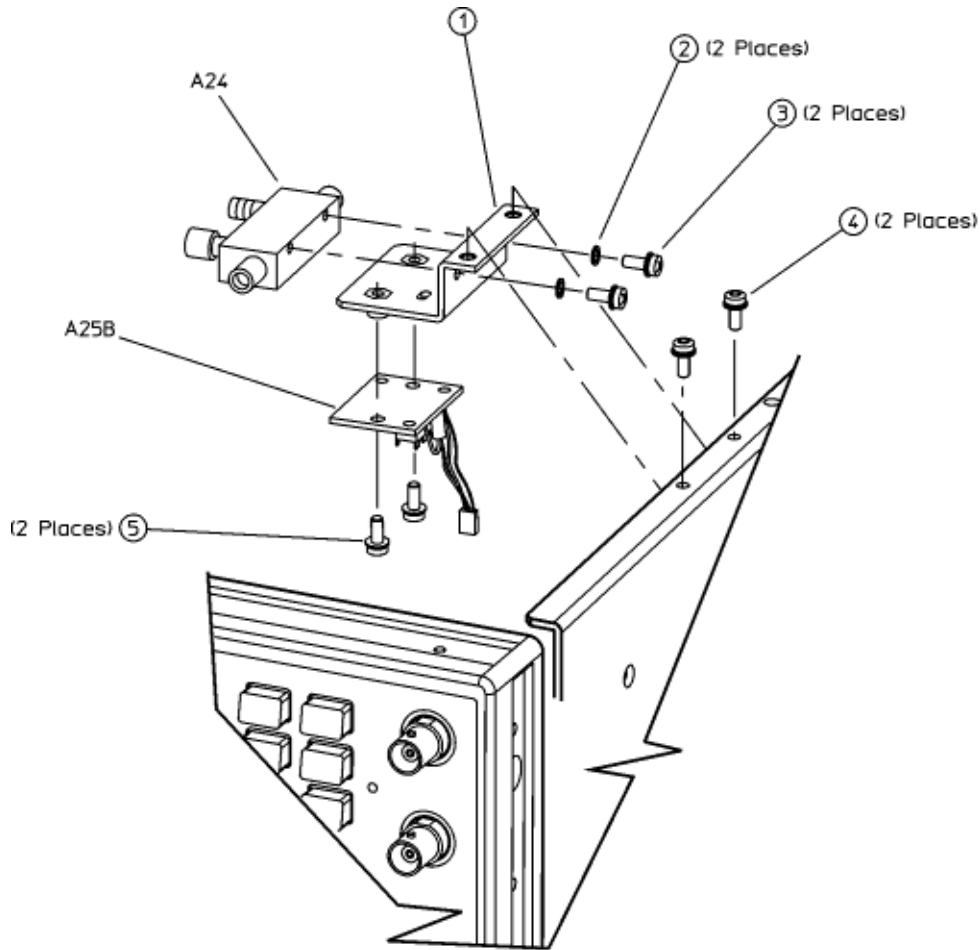

se923a

### Microcircuit Interface Deck Top View

**Table 3-22**                    **Microcircuit Interface Deck Top View**

Item No.	Description	Qty	Part Number
1	Screw-Machine M3.0 x 14 CW-PN-TX	1	0515-0665

Figure 3-22 Microcircuit Interface Deck Top View

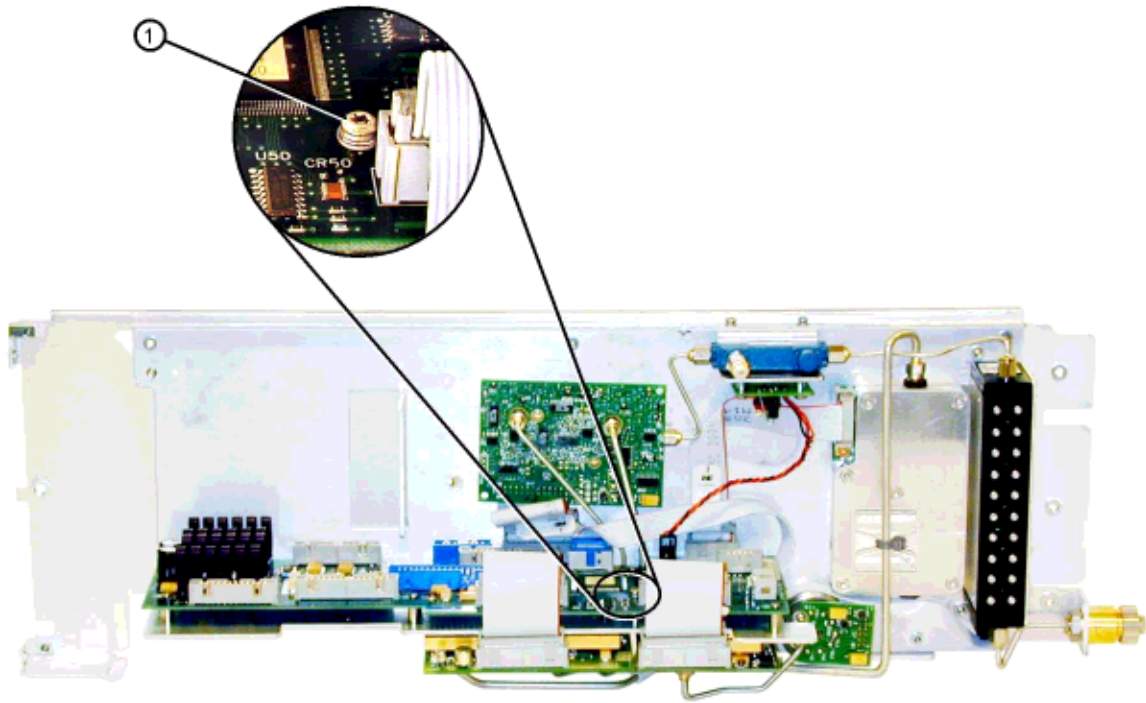

se955a

**Main Chassis and MID Bottom View**

**Table 3-23 Main Chassis and MID Bottom View**

Item No.	Description	Qty	Part Number
1	Rib Bracket	1	E8251-00008
2	Cable Retainer Clip	3	E8251-40001
3	Screw-Machine M30. x 8 CW-PN-TX (A31 Motherboard to main chassis)	15	0515-0372
4	Screw-Machine M30. x 8 CW-PN-TX (A28 YIG Oscillator to MID)	2	0515-0372
5	Screw-Machine M30. x 20 CW-PN-TX (A30 Modulator Filter with Standard or High Power to MID)	3	0515-1410
6	Screw-Machine M30. x 20 CW-PN-TX (A29 20 GHz Doubler to MID)	2	0515-1410

Figure 3-23

Main Chassis and MID Bottom View

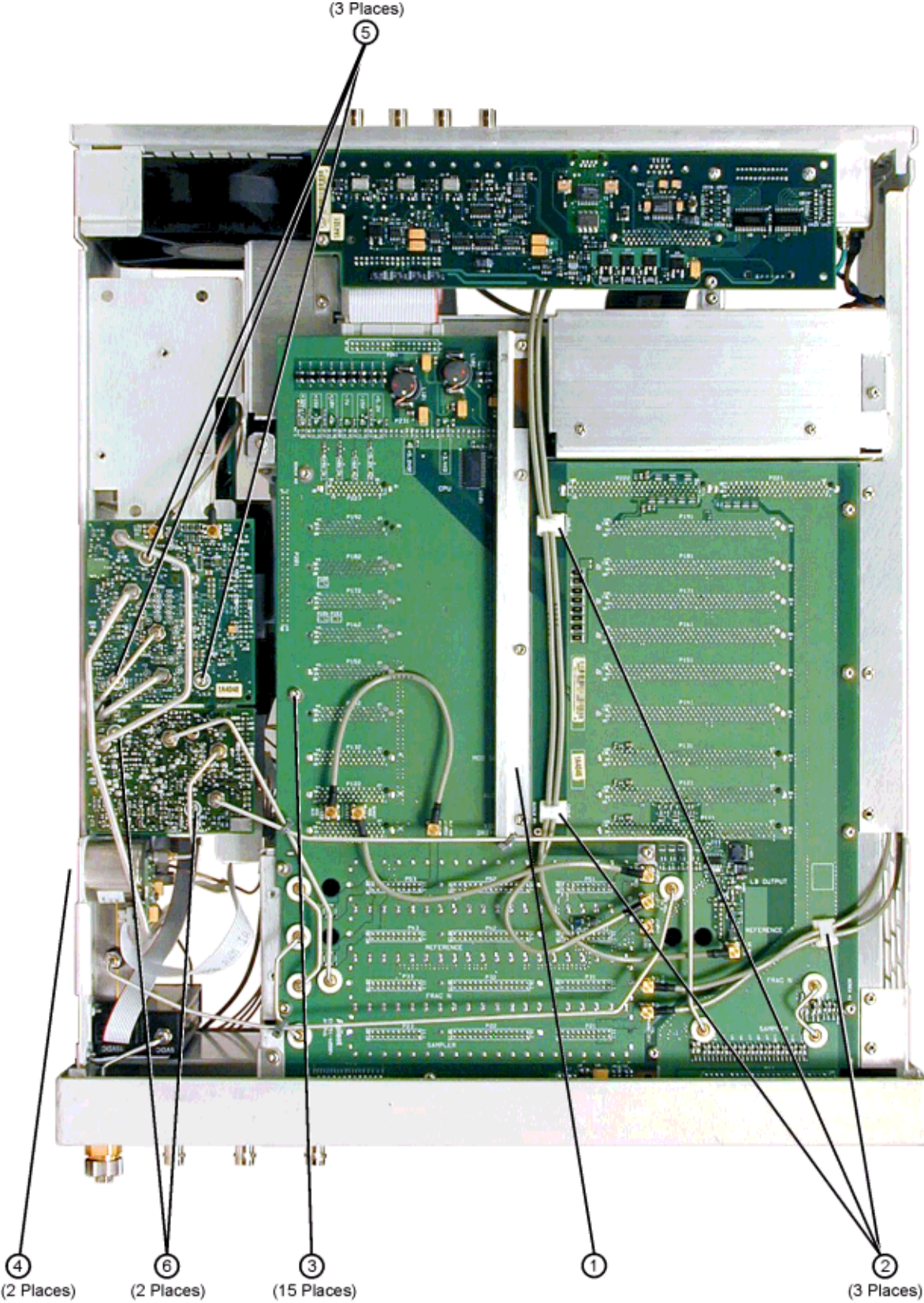

**2.4 mm RF Output Connector (E8244A and E8254A Models Only)**

**Table 3-24 2.4 mm RF Output Connector (E8244A and E8254A Model Only)**

Item No.	Description	Qty	Part Number
1	Adapter-Male 2.4 mm	1	5063-1700
2	Adapter Bracket	1	E8251-00018
3	Screw-Machine M4.0 x 10 FL-TX (front frame to adapter bracket)	1	0515-1269
4	Washer lock .377ID	1	2190-0016
5	Nut-Hex	1	E8251-20067
	W25 Semi-Rigid Cable (refer to <a href="#">Table 3-11 on page 3-28.</a> )		

**Figure 3-24 2.4 mm RF Output Connector (E8244A and E8254A Models Only)**

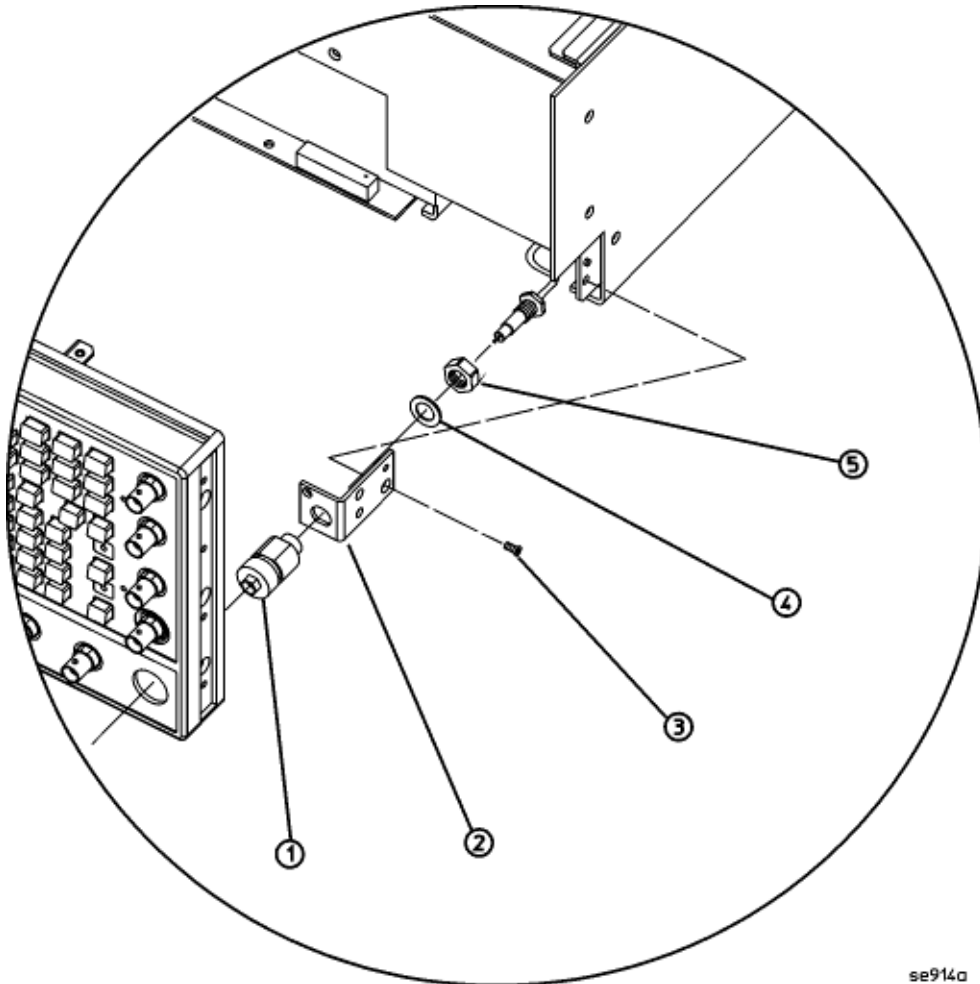

se914a



**APC 3.5 RF Output Connector (E8241A and E8251A Models Only)**

**Table 3-25 APC 3.5 RF Output Connector (E8241A and E8251A Models Only)**

Item No.	Description	Qty	Part Number
1	Adapter-Male APC 3.5	1	08673-60040
2	Spacer APC 3.5	1	E8251-20068
3	Adapter Bracket	1	E8251-00016
4	Screw-Machine M4.0 x 10 FL-TX	1	0515-1269
5	Washer lock .377ID	1	2190-0016
6	Nut-Hex	1	2950-0001
	W25 Semi-Rigid Cable (refer to <a href="#">Table 3-12 on page 3-30.</a> )		

**Figure 3-25 APC 3.5 RF Output Connector (E8241A and E8251A Models Only)**

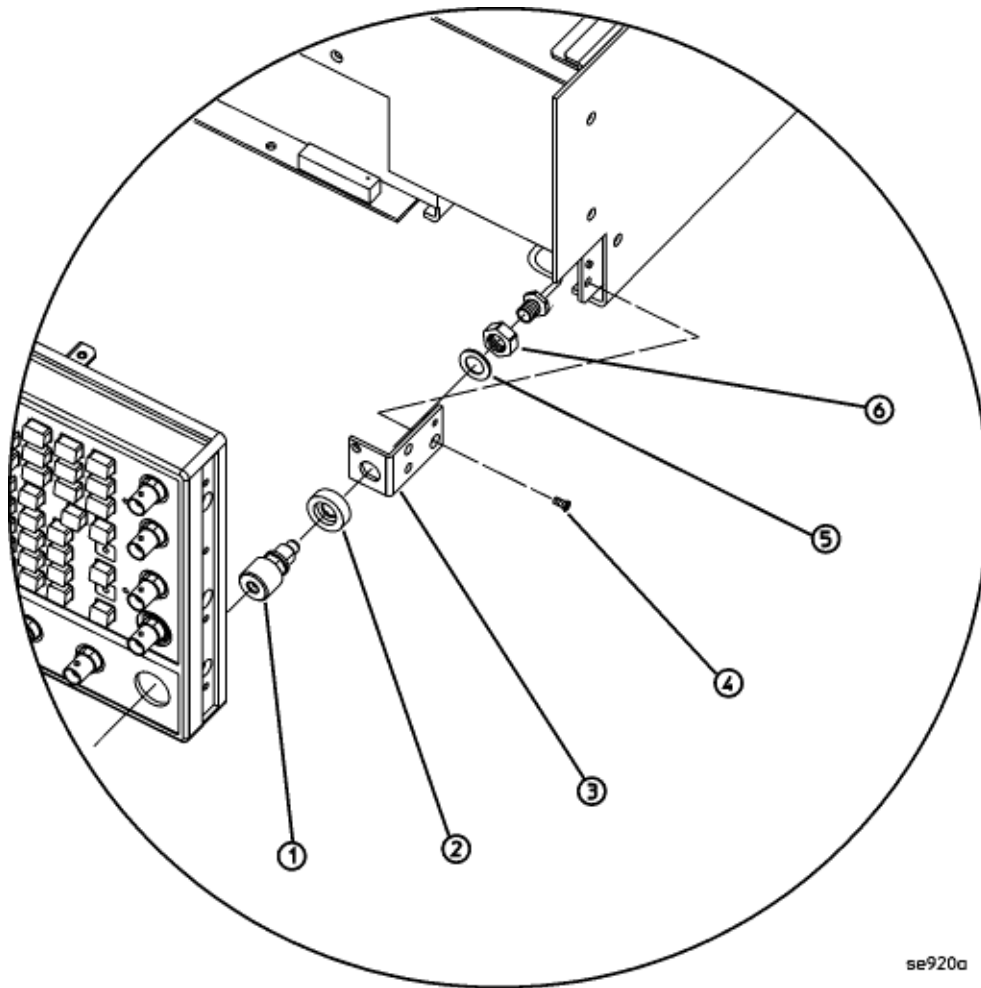

se920a

**Type-N RF Output Connector (E8241A and E8251A with Option 1ED Models Only)**

**Table 3-26**                    **Type-N RF Output Connector**  
**(E8241A and E8251A with Option 1ED Models Only)**

Item No.	Description	Qty	Part Number
1	Adapter-Type-N (f)	1	08559-60002
2	Spacer	1	E8251-20067
3	Adapter Bracket	1	E8251-00018
4	Screw-Machine M4.0 x 10 FL-TX	1	0515-1035
5	Washer lock	1	2190-0102
6	Nut-Hex	1	2950-0132
	W25 Semi-Rigid Cable (refer to <a href="#">Table 3-12 on page 3-30.</a> )		

**Figure 3-26**                    **Type-N RF Output Connector**  
**(E8241A and E8251A with Option 1ED Models Only)**

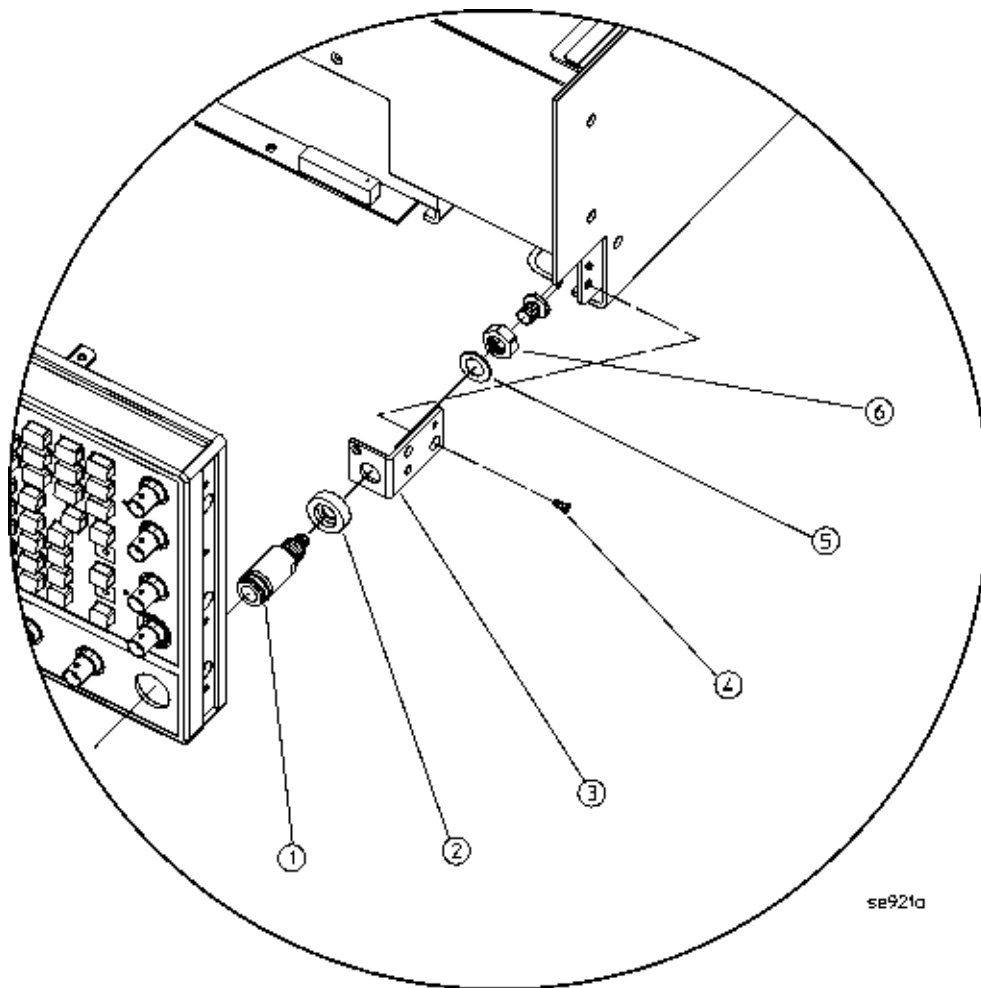

## Main Chassis with Inside Cover and Right-Side Support Wall

**Table 3-27** Main Chassis with Inside Cover and Right-Side Support Wall

Item No.	Description	Qty	Part Number
1	Main Chassis Inside Top Cover	1	E8251-00010
2	Screw-Machine M3.0 x 08 FL-TX (inside top cover to main chassis and rear panel)	9	0515-0431
3	Screw-Machine M3.0 x 08 CW-PN-TX (rear panel to right-side support wall)	3	0515-0372
4	Screw-Machine M3.0 x 08 FL-TX (microcircuit interface deck to right-side support wall)	8	0515-1035
5	Right-Side Support Wall	1	E8251-00014
6	Microcircuit Interface Deck	1	E8251-00004
7	Main Chassis	1	E8251-60030

**Figure 3-27** Main Chassis with Inside Cover and Right-Side Support Wall

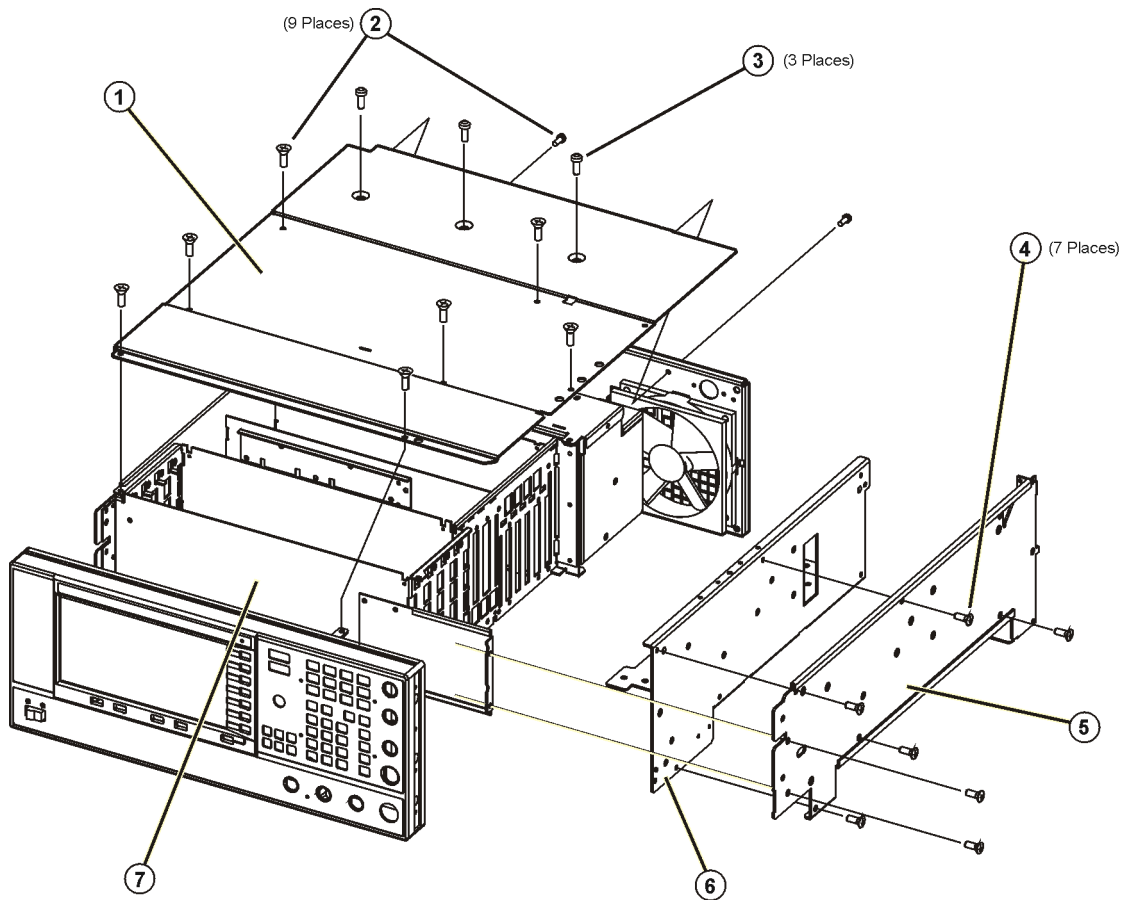

se931a

### Outer and Inner Instrument Covers and Associated Parts

**Table 3-28** Outer and Inner Instrument Covers and Associated Parts

Item No.	Description	Qty	Part Number
1	Assy-Strap Handle - includes the following parts:	1	E8251-60067
	Strap Assembly	1	
	Ground Spring	2	
	Handle Retainer	2	
	End Cap	2	
	Screw-Machine M5 x 18 FL-TX	2	
2	Rear Feet Screws	4	0515-0636
3	Rear-Panel Feet	4	5041-9611
4	Feet-Bottom	4	5041-9167
5	Tilt Stand	2	1460-1345
6	Outside Instrument Cover	1	E8251-00012

**Figure 3-28** Outer and Inner Instrument Covers and Associated Parts

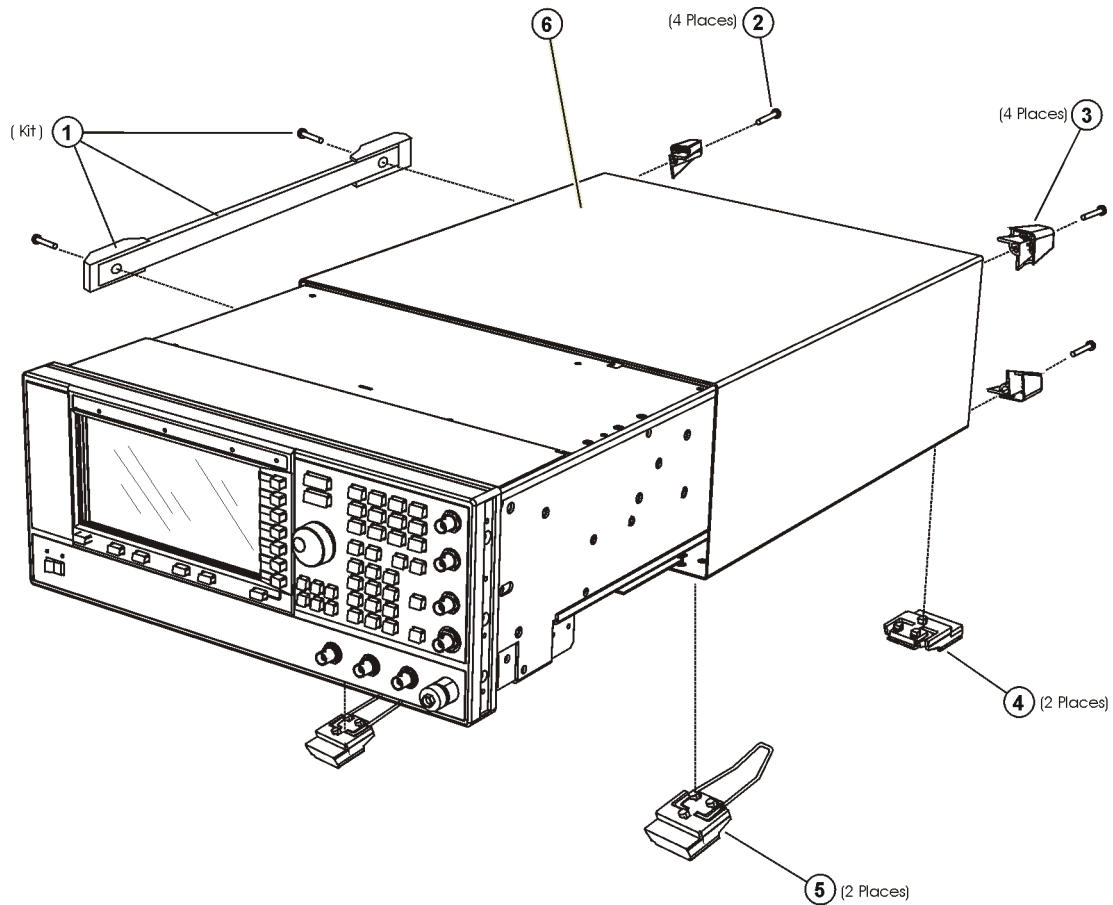

se92a

---

## Miscellaneous

This section lists part numbers for miscellaneous items that can be used with your signal generator.

**Accessories**

**Table 3-29 Accessories**

Description	Part Number
Test Cable	E8251-20088

**Documentation**

**Table 3-30 Available PSG Documentation**

Document Type	Description	Part Number
PSG Document Set	<ul style="list-style-type: none"> <li>• user’s, programming, calibration, and service guides</li> <li>• error messages</li> </ul>	E8251-90020
Documentation CD-ROM	<ul style="list-style-type: none"> <li>• PDF files of PSG Documentation Set</li> <li>• Intuilink software</li> <li>• programming examples</li> </ul>	E8251-90021
Installation Guide	<ul style="list-style-type: none"> <li>• installation instructions and requirements</li> <li>• operation verification procedure</li> <li>• warranty, safety, and regulatory information</li> </ul>	E8251-90022
User’s Guide	<ul style="list-style-type: none"> <li>• description of features and functions</li> <li>• fundamental signal generator operation tutorials</li> <li>• optimization procedures</li> <li>• basic troubleshooting</li> <li>• key descriptions and softkey menu maps</li> </ul>	E8251-90023
Programming Guide	<ul style="list-style-type: none"> <li>• SCPI command reference</li> <li>• programming examples</li> <li>• command compatibility tables</li> </ul>	E8251-90025
Error Messages	<ul style="list-style-type: none"> <li>• error message definitions</li> </ul>	E8251-90027
Data Sheet	<ul style="list-style-type: none"> <li>• available options</li> <li>• warranted specifications and typical performance</li> </ul>	5988-2412EN
Calibration Guide	<ul style="list-style-type: none"> <li>• service software instructions</li> <li>• performance tests and adjustment procedures</li> </ul>	E8251-90035
Service Guide	<ul style="list-style-type: none"> <li>• assembly level documentation</li> <li>• troubleshooting procedures</li> </ul>	E8251-90030

**Electrostatic Discharge (ESD) Protective Supplies**

**Table 3-31 Electrostatic Discharge (ESD) Protective Supplies**

Description	Part Number
ESD connector end cap front-panel RF output	1401-0247
ESD connector end cap rear panel SMI	1252-4690
ESD connector end cap-GPIB	1252-5007

**Table 3-31            Electrostatic Discharge (ESD) Protective Supplies**

Description	Part Number
ESD connector end cap coherent carrier cut	1252-4696
2 X 4 Ft. Antistatic Table Mat with 15 FT. Ground Wire	9300-0797
5 Ft. Grounding Cord (for wrist strap)	9300-0980
Adjustable Antistatic Wrist Strap	9300-1367





---

## **4 Post-Repair Procedures**

## Post-Repair Procedures Matrix

Table 4-1 Adjustments for Assemblies A1 through A20

Adjustments	Replaced Assembly															
	A1 Keyboard	A2 Display	A2DS1 Backlight	A3 Power Switch	A4 Inverter	A5 Sampler	A6 Frac-N	A7 Reference	A8 Output	A9 YIG Driver	A10 ALC	A11 Pulse/Analog Mod Gen	A18 CPU	A19 Power Supply	A20 SMI [Source Module Interface]	RF Output Connector
The following adjustments are listed in the order that they should be performed for proper calibration.																
ADC Calibration						✓	✓	✓	✓	✓	✓	✓	✓			
YIG-Driver Pre-Tune Calibration										✓						
VCO Bias Frac-N Calibration							✓									
Internal Source Calibration												✓				
AM Audio Path Offset Calibration											✓	✓				
KV vs. Frequency Calibration							✓									
Timebase Calibration								✓								
FM Scale Offset Calibration							✓			✓		✓				
FM Path Offset Calibration							✓			✓		✓				
FM In-band Offset Calibration							✓			✓		✓				
FM Inverting Amplifier Offset Calibration												✓				
FM 1/2 Path Ratio Gain Calibration							✓			✓		✓				
Mod Source Relative Gain Calibration							✓			✓		✓				
FM/PM Out-of-Band Calibration							✓			✓		✓				
FM/PM YO Frequency Compensation Calibration							✓			✓		✓				
DC FM Calibration							✓			✓		✓				
Low Frequency Output Calibration												✓				
External Input Peak Detector Calibration												✓				
ALC Dynamic Calibration									✓		✓					
Power Flatness Calibration									✓		✓					✓
Attenuator Calibration, Low Band and High Band Power																
Attenuator Calibration, High Band and High Power																
Attenuator Calibration, Low Band and Low Power																
Attenuator Calibration, High Band and Low Power																
ALC Modulator Calibration									✓		✓					
AM Gain Calibration									✓		✓	✓				
Gain Adjustment Bypass Calibration (Frequencies <= 3.2 GHz)							✓			✓						
Pulse Width Calibration									✓			✓				

**Table 4-2 Adjustments for Assemblies A21 through A32, B1, and RF Output Connector**

Adjustments	Replaced Assembly																			
	A21 Rear Panel	A22 Line Module	A23 115 dB Attenuator	A23 Lowband Coupler/Detector	A24 20 GHz Coupler	A24 40 GHz Coupler	A25 20 GHz Detector	A25 40 GHz Detector	A25B Detector Bias Board	A26 MID	A27 40 GHz Doubler	A28 YIG Oscillator	A29 20 GHz Doubler	A30 Mod Filter with High Power (Option 1EA)	A30 Mod Filter with Standard Power	A31 Motherboard	A32 10 MHz Crystal Oscillator	B1 Fan	RF Output Connector	
ADC Calibration										✓										
YIG-Driver Pre-Tune Calibration												✓								
VCO Bias Frac-N Calibration																				
Internal Source Calibration																				
AM Audio Path Offset Calibration																				
KV vs. Frequency Calibration																				
Timebase Calibration																		✓		
FM Scale Offset Calibration												✓								
FM Path Offset Calibration												✓								
FM In-band Offset Calibration												✓								
FM Inverting Amplifier Offset Calibration												✓								
FM 1/2 Path Ratio Gain Calibration												✓								
Mod Source Relative Gain Calibration												✓								
FM/PM Out-of-Band Calibration												✓								
FM/PM YO Frequency Compensation Calibration												✓								
DC FM Calibration												✓								
Low Frequency Output Calibration												✓								
External Input Peak Detector Calibration												✓								
ALC Dynamic Calibration				✓	✓	✓	✓	✓	✓					✓	✓					
Power Flatness Calibration				✓	✓	✓	✓	✓	✓					✓	✓					
Attenuator Calibration, Low Band and High Band Power			✓																	
Attenuator Calibration, High Band and High Power			✓																	
Attenuator Calibration, Low Band and Low Power			✓																	
Attenuator Calibration, High Band and Low Power			✓																	
ALC Modulator Calibration														✓	✓					
AM Gain Calibration														✓	✓					
Gain Adjustment Bypass Calibration (Frequencies <= 3.2 GHz)																				
Pulse Width Calibration														✓	✓					

**Table 4-3 Performance Tests for Assemblies A1 through A20**

Performance Tests	Replaced Assembly														
	A1 Keyboard	A2 Display	A2DS1 Backlight	A3 Power Switch	A4 Inverter	A5 Sampler	A6 Frac-N	A7 Reference	A8 Output	A9 YIG Driver	A10 ALC	A11 Pulse/Analog Mod Gen	A18 BT1	A19 Power Supply	A20 SMI [Source Module Interface]
The following performance tests are listed in the order that they should be performed to minimize changes in test equipment configurations.															
Self Tests	✓	✓	✓	✓	✓	✓	✓	✓	✓	✓	✓	✓	✓	✓	✓
Maximum Leveled Output Power							✓		✓		✓				
Power Level Accuracy									✓		✓				
Internal Pulse Modulation Level Accuracy									✓			✓			
Internal Pulse Modulation Rise/Fall Time									✓			✓			
Internal Pulse Modulation Minimum Pulse Width									✓		✓	✓			
DC FM Carrier Offset							✓					✓			
External AM Frequency Response									✓		✓	✓			
Internal FM Frequency Response							✓			✓		✓			
External Phase Modulation Frequency Response							✓			✓		✓			
Internal FM Distortion							✓					✓			
Internal Phase Modulation Distortion							✓					✓			
External FM Deviation Accuracy							✓			✓		✓			
Internal Phase Modulation Deviation Accuracy							✓			✓		✓			
External Pulse Modulation ON/OFF Ratio									✓			✓			
Harmonic Spurious							✓		✓						
Sub-Harmonic Spurious							✓								
Non-Harmonic Spurious						✓	✓	✓	✓						
Single-Sideband Phase Noise						✓	✓	✓	✓	✓					

Table 4-4 Performance Tests for Assemblies A21 through A32, B1, and RF Output Connector

Performance Tests	Replaced Assembly																		
	A21 Rear Panel Interface	A22 Line Module	AT1 115 dB Attenuator	A23 Lowband Coupler/Detector	A24 20 GHz Coupler	A24 40 GHz Coupler	A25 20 GHz Detector	A25 40 GHz Detector	A25B Detector Bias Board	A26 MID [Microcircuit Interface Deck]	A27 40 GHz Doubler	A28 YIG Oscillator	A29 20 GHz Doubler	A30 Mod Filter with High Power (Option 1EA)	A30 Mod Filter with Standard Power	A31 Motherboard	A32 10 MHz Crystal Oscillator	B1 Fan	RF Output Connector
Self Tests	✓	✓	✓	✓	✓	✓	✓	✓	✓	✓	✓	✓	✓	✓	✓	✓	✓	✓	✓
Maximum Leveled Output Power			✓	✓	✓	✓	✓	✓		✓	✓	✓	✓	✓	✓				✓
Power Level Accuracy			✓	✓	✓	✓	✓	✓	✓	✓			✓	✓	✓	✓			✓
Internal Pulse Modulation Level Accuracy														✓	✓				
Internal Pulse Modulation Rise/Fall Time														✓	✓				
Internal Pulse Modulation Minimum Pulse Width														✓	✓				
DC FM Carrier Offset																			
External AM Frequency Response																			
Internal FM Frequency Response												✓							
External Phase Modulation Frequency Response												✓							
Internal FM Distortion																			
Internal Phase Modulation Distortion																			
External FM Deviation Accuracy												✓							
Internal Phase Modulation Deviation Accuracy												✓							
External Pulse Modulation ON/OFF Ratio														✓	✓				
Harmonic Spurious									✓	✓	✓	✓	✓	✓	✓				
Sub-Harmonic Spurious										✓	✓	✓							
Non-Harmonic Spurious																✓	✓	✓	
Single-Sideband Phase Noise											✓						✓		



---

## **5 Safety and Regulatory**

## Safety and Regulatory

This chapter provides information on the following:

- Safety Notes
- General Safety Information
- Lithium Battery Disposal
- Warranty and Legal Information

The following safety notes are used throughout this manual. Familiarize yourself with each of the notes and its meaning before operating this instrument.

---

**CAUTION** Caution denotes a hazard. It calls attention to a procedure that, if not correctly performed or adhered to, would result in damage to or destruction of the product. Do not proceed beyond a caution sign until the indicated conditions are fully understood and met.

---

---

**WARNING** Warning denotes a hazard. It calls attention to a procedure which, if not correctly performed or adhered to, could result in injury or loss of life. Do not proceed beyond a warning note until the indicated conditions are fully understood and met.

---



---

## General Safety Considerations

The following safety notes apply specifically to signal generators. These notes also appear in other chapters of this service guide as required.

---

**WARNING**    **These servicing instructions are for use by qualified personal only. To avoid electrical shock, do not perform any servicing unless you are qualified to do so.**

---

---

**WARNING**    **The opening of covers or removal of parts is likely to expose dangerous voltages. Disconnect the product from all voltage sources before starting to open.**

---

---

**WARNING**    **The detachable power cord is the instrument disconnecting device. It disconnects the mains circuits from the mains supply before other parts of the instrument. The front panel switch is only a standby switch and is not a LINE switch (disconnecting device).**

---

---

**WARNING**    **The power cord is connected to internal capacitors that may remain live for 5 seconds after disconnecting the plug from its power supply.**

---

---

**WARNING**    **This is a Safety Class 1 Product (provided with a protective earthing ground incorporated in the power cord). The mains plug shall only be inserted in a socket outlet provided with a protective earth contact. Any interruption of the protective conductor inside or outside of the product is likely to make the product dangerous. Intentional interruption is prohibited.**

---

---

**WARNING**    **Replace battery only with the same or equivalent type recommended. Discard used batteries according to manufacturer's instructions.**

---

---

**CAUTION**    Many of the assemblies in this instrument are very susceptible to damage from electrostatic discharge (ESD). Perform service procedures only at a static-safe workstation and wear a grounding strap.

---

## Lithium Battery Disposal

When the battery on the A14 CPU is exhausted and/or ready for disposal, dispose of it according to your country's requirements. You can return the battery to your nearest Agilent Technologies Sales and Service office for disposal, if required.

**Figure 5-1**



DO NOT THROW BATTERIES AWAY BUT  
COLLECT AS SMALL CHEMICAL WASTE.

sk780a

## **Warranty**

This Agilent Technologies product is warranted against defects in material and workmanship for a period of three years from date of shipment. During the warranty period, Agilent Technologies will, at its option, either repair or replace products which prove to be defective.

For warranty service or repair, this product must be returned to a service facility designated by Agilent Technologies. Buyer shall prepay shipping charges to Agilent Technologies and Agilent Technologies shall pay shipping charges to return the product to Buyer. However, Buyer shall pay all shipping charges, duties, and taxes for products returned to Agilent Technologies from another country.

Agilent Technologies warrants that its software and firmware designated by Agilent Technologies for use with an instrument will execute its programming instructions when properly installed on that instrument. Agilent Technologies does not warrant that the operation of the instrument, or software, or firmware will be uninterrupted or error-free.

### **Limitation of Warranty**

The foregoing warranty shall not apply to defects resulting from improper or inadequate maintenance by Buyer, Buyer-supplied software or interfacing, unauthorized modification or misuse, operation outside of the environmental specifications for the product, or improper site preparation or maintenance.

**NO OTHER WARRANTY IS EXPRESSED OR IMPLIED. AGILENT TECHNOLOGIES SPECIFICALLY DISCLAIMS THE IMPLIED WARRANTIES OF MERCHANTABILITY AND FITNESS FOR A PARTICULAR PURPOSE.**

### **Exclusive Remedies**

**THE REMEDIES PROVIDED HEREIN ARE BUYER'S SOLE AND EXCLUSIVE REMEDIES. AGILENT TECHNOLOGIES SHALL NOT BE LIABLE FOR ANY DIRECT, INDIRECT, SPECIAL, INCIDENTAL, OR CONSEQUENTIAL DAMAGES, WHETHER BASED ON CONTRACT, TORT, OR ANY OTHER LEGAL THEORY.**

## **Assistance**

Product maintenance agreements and other customer assistance agreements are available for Agilent Technologies products. For any assistance, contact your nearest Agilent Technologies sales and service office.

## **Notice**

The information contained in this document is subject to change without notice.

Agilent Technologies makes no warranty of any kind with regard to this material, including but not limited to, the implied warranties of merchantability and fitness for a particular purpose. Agilent Technologies shall not be liable for errors contained herein or for incidental or consequential damages in connection with the furnishing, performance, or use of this material.

## **Certification**

Agilent Technologies Company certifies that this product met its published specifications at the time of shipment from the factory. Agilent Technologies further certifies that its calibration measurements are traceable to the United States National Institute of Standards and Technology, to the extent allowed by the Institute's calibration facility, and to the calibration facilities of other International Standards Organization members.

**A**

- A1 keyboard
  - part number, [3-10](#)
  - removal replacement, [2-10](#)
- A10 ALC
  - part number, [3-12](#)
  - removal replacement, [2-30](#)
- A11 pulse/analog modulation generator
  - part number, [3-12](#)
  - removal replacement, [2-32](#)
- A18 CPU
  - part number, [3-12](#)
  - removal replacement, [2-34](#)
- A18BT1
  - part number, [3-20](#)
  - removal replacement, [2-36](#)
- A19 power supply
  - part number, [3-12](#)
  - removal replacement, [2-38](#)
- A2 display
  - part number, [3-10](#)
  - removal replacement, [2-12](#)
- A20 SMI (Option 1EE)
  - part number, [3-16](#)
  - removal replacement, [2-42](#)
- A21 rear-panel
  - part number, [3-16](#)
  - removal replacement, [2-44](#)
- A22 line module
  - part number, [3-16](#)
  - removal replacement, [2-46](#)
- A23 lowband coupler/detector
  - part number, [3-17](#)
  - removal replacement, [2-50](#)
- A24 20 GHz coupler (E8241A/E8251A models only)
  - part number, [3-17](#)
  - removal replacement, [2-52](#)
- A24 40 GHz coupler (E8244A/E8254A models only)
  - part number, [3-17](#)
  - removal replacement, [2-54](#)
- A25 20 GHz detector with bias board (E8241A/E8251A models only)
  - part number, [3-17](#)
  - removal replacement, [2-56](#)
- A25 40 GHz detector with bias board (E8244A/E8254A models only)
  - part number, [3-17](#)
  - removal replacement, [2-58](#)
- A25B detector bias board
  - part number, [3-17](#)
- A26 microcircuit interface deck (MID)
  - part number, [3-17](#)
  - removal replacement, [2-60](#)
- A27 40 GHz doubler
  - Option 1EA, [3-17](#)
  - removal replacement, [2-62](#)
  - standard power, [3-17](#)
- A28 YIG oscillator
  - part number, [3-18](#)
  - removal and replacement, [2-64](#)
- A29 20 GHz doubler
  - part number, [3-18](#)
  - removal and replacement, [2-66](#)
- A2DS1 display backlight
  - part number, [3-10](#)
  - removal replacement, [2-14](#)
- A3 power switch
  - part number, [3-10](#)
  - removal replacement, [2-16](#)
- A30 modulator filter
  - Option 1EA, [3-18](#)
  - removal and replacement, [2-68](#)
  - standard power, [3-18](#)
- A31 motherboard
  - part number, [3-14](#)
  - removal and replacement, [2-70](#)
- A32 10 MHz crystal oscillator (Option UNJ)
  - part number, [3-16](#)
  - removal and replacement, [2-72](#)
- A4 inverter
  - part number, [3-10](#)
  - removal replacement, [2-18](#)
- A5 sampler
  - part number, [3-12](#)
  - removal replacement, [2-20](#)
- A6 Frac-N
  - part number, [3-12](#)
  - removal replacement, [2-22](#)
- A7 reference
  - part number, [3-12](#)
  - removal replacement, [2-24](#)
- A8 output
  - part number, [3-12](#)
  - removal replacement, [2-26](#)
- A9 YIG driver
  - part number, [3-12](#)
  - removal replacement, [2-28](#)
- accessories
  - test cable, [3-56](#)
- antistatic materials, [3-56](#)

## assembly replacement

- A1 keyboard, [2-10](#)
- A10 ALC, [2-30](#)
- A11 pulse/analog modulation generator, [2-32](#)
- A18 CPU, [2-34](#)
- A18BT1, [2-36](#)
- A19 power supply, [2-38](#)
- A2 display, [2-12](#)
- A20 SMI (Option 1EE), [2-42](#)
- A21 rear-panel interface, [2-44](#)
- A22 line module, [2-46](#)
- A23 lowband coupler/detector, [2-50](#)
- A24 20 GHz coupler (E8241A/E8251A models only), [2-52](#)
- A24 40 GHz coupler (E8244A/E8254A models only), [2-54](#)
- A25 20 GHz detector with bias board (E8241A/E8251A models only), [2-56](#)
- A25 40 GHz detector with bias board (E8244A/E8254A models only), [2-58](#)
- A26 microcircuit interface deck (MID), [2-60](#)
- A27 40 GHz doubler, [2-62](#)
- A28 YIG oscillator, [2-64](#)
- A29 20 GHz doubler, [2-66](#)
- A2DS1 display backlight, [2-14](#)
- A3 power switch, [2-16](#)
- A30 modulator filter, [2-68](#)
- A31 motherboard, [2-70](#)
- A32 10 MHz crystal oscillator (Option UNJ), [2-72](#)
- A4 inverter, [2-18](#)
- A5 sampler, [2-20](#)
- A6 Frac-N, [2-22](#)
- A7 reference, [2-24](#)
- A8 output, [2-26](#)
- A9 YIG driver, [2-28](#)
- AT1 115 dB attenuator (Option 1E1), [2-48](#)
- B1 fan, [2-74](#)
- before replacing an assembly, [2-2](#)
- front panel, [2-8](#)
- inner instrument cover, [2-6](#)
- list of replaceable assemblies, [2-3](#)
- outer instrument cover, [2-4](#)
- rear panel, [2-40](#)
- safety, [2-2](#)
- AT1 115 dB attenuator (Option 1E1)
  - part number, [3-17](#)
  - removal replacement, [2-48](#)

## B

- B1 fan
  - part number, [3-16](#)
  - removal and replacement, [2-74](#)
- battery
  - part number, [3-20](#)

## C

- cables, [3-21](#)
- contacting agilent
  - packaging your signal generator, [1-85](#)
- contacting Agilent Technologies
  - returning your signal generator, [1-86](#)
  - servicing your signal generator, [1-86](#)

## D

- defective assemblies, [3-4](#)
- documentation, [3-56](#)

## E

- electrostatic discharge
  - supplies, [3-56](#)
- exchange assemblies, [3-4](#)

## F

- front panel
  - inside view, [3-22](#)
  - removal and replacement, [2-8](#)
- front panel subassemblies
  - removal and replacement
    - illustrated, [2-13](#), [2-15](#), [2-17](#), [2-19](#)

## H

- hardware and other instrument parts, [3-36](#)

## I

- inner instrument cover
  - removal and replacement, [2-6](#)

## O

- ordering information, [3-2](#)
- outer instrument cover
  - removal and replacement, [2-4](#)



---

**R**

- rear panel
  - removal replacement, [2-40](#)
- replaceable assemblies, [2-3](#)
- replaceable parts
  - cables, [3-21](#)
  - hardware and other instrument parts, [3-36](#)
  - list of major assemblies, [3-6](#)
  - major assemblies bottom view, [3-8](#)
  - major assemblies microcircuit interface deck view, [3-9](#)
  - major assemblies top view, [3-7](#)
  - ordering information, [3-2](#)
- replacement
  - front panel subassemblies
    - illustrated, [2-13](#), [2-15](#), [2-17](#), [2-19](#)
- returning your signal generator, [1-86](#)

**S**

- servicing your signal generator, [1-86](#)

**T**

- troubleshooting
  - A18 CPU self-test, [1-6](#)
  - A28 YIG oscillator, [1-76](#)
  - A29 20 GHz doubler, [1-76](#)
  - A5 sampler, [1-75](#)
  - A6 frac-n, [1-76](#)
  - A9 YIG driver, [1-76](#)
  - assembly level, [1-17](#)
  - B1 fan, [1-21](#)
  - frequency generation description, [1-79](#)
  - overall block description, [1-69](#)
  - power supply vs. assembly matrix, [1-17](#)
  - power supply,instrument level, [1-4](#)
  - power-on LED, [1-21](#)
  - reference/synthesis loop, [1-75](#)
  - rf path description, [1-79](#)
  - self-tests 10xx, [1-36](#)
  - self-tests 2xx, [1-24](#)
  - self-tests 3xx, [1-26](#)
  - self-tests 4xx, [1-27](#)
  - self-tests 6xx, [1-29](#)
  - self-tests 7xx, [1-31](#)
  - self-tests 9xx, [1-34](#)
  - standby LED, [1-21](#)

