

Quick Start Guide
Agilent Technologies
ESG Family Signal Generators

Serial Number Prefixes:

(Affix Label Here)



Part No. E4400-90326

Printed in USA
October 2000

Supersedes April 2000

© Copyright 1999, 2000 Agilent Technologies

Contents

1. Getting Started

The Signal Generator at a Glance	1-2
Creating an FM Signal	1-3
Setting the Carrier Frequency	1-3
Setting the Power Level	1-3
Setting the FM Deviation	1-4
Setting the FM Rate	1-4
Turning On Frequency Modulation	1-4
Creating a Step Sweep and a List Sweep	1-5
Configuring a Step Sweep	1-5
Turning On Continuous Step Sweep	1-6
Configuring a List Sweep Using Step Sweep Data	1-7
Turning On List Sweep for a Single Sweep	1-8
Saving and Recalling an Instrument State	1-9
Creating an Instrument State	1-9
Saving an Instrument State	1-10
Recalling an Instrument State	1-10
Setting Up a Digital Modulation in the GSM Format	1-11
Setting the Carrier Frequency	1-11
Setting the Power Level	1-11
Selecting the Data Format	1-12
Setting Up Timeslot 0	1-12
Setting Up Timeslot 7	1-13
Turning On the GSM Format and the Modulation	1-14

2. Exploring the User Interface

Front Panel	2-2
Display	2-7
Rear Panel	2-11

1 Getting Started

This chapter will help you learn how to do the following with your signal generator:

- create an FM signal
- generate step and list sweeps
- use the save and recall functions
- set up a digital modulation in GSM format (Option UN8 only)

The Signal Generator at a Glance

Refer to the figure and descriptions below as you use the procedures in this chapter. For detailed front and rear panel information, refer to [Chapter 2, “Exploring the User Interface.”](#)

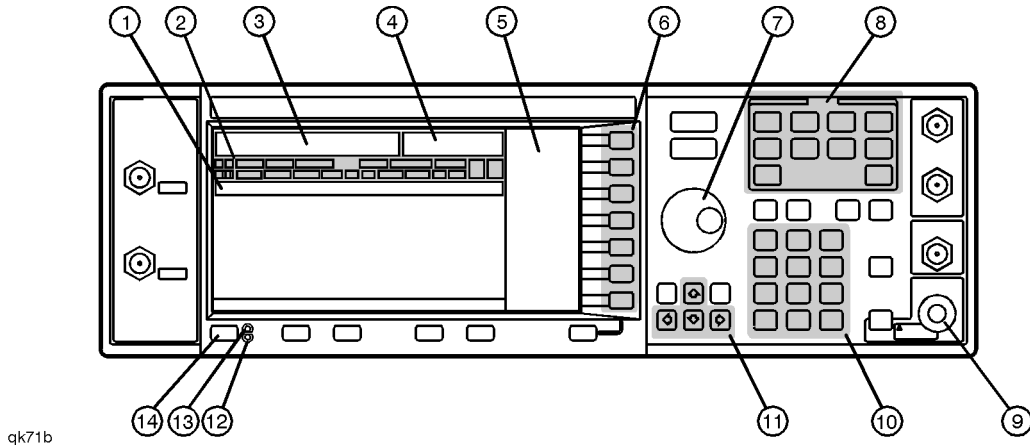

1. **Active Entry Area.** The current active function is shown in this area.
2. **Annunciators.** These display annunciators show the status of various signal generator functions.
3. **Frequency Area.** The current CW frequency is shown in this portion of the display.
4. **Amplitude Area.** The current output power level is shown in this portion of the display.
5. **Softkey Labels.** The softkey labels define the functions of the corresponding softkeys immediately to the right of the labels.
6. **Softkeys.** Pressing a softkey activates the function indicated by the label on the display directly to the left of the softkey.
7. **Knob.** The knob is used to increase or decrease a numeric value.
8. **Menu Keys.** These hardkeys provide access to the signal generator's primary functionality.
9. **RF Output Connector.** This female Type-N connector is the output connector for RF signals.
10. **Numeric Keypad.** The numeric keypad consists of digit, decimal point, and backspace keys. The backspace key can also be used to change the sign of a numeric value.
11. **Arrow Keys.** The up and down arrow keys increase or decrease numeric values. The left and right arrow keys move the cursor.
12. **Standby LED.** This yellow LED lights when the instrument is in standby mode.
13. **Line Power LED.** This green LED lights when power is cycled on.
14. **Power Switch.** Pressing this hardkey toggles the power between on and standby.

Creating an FM Signal

This procedure will show you how to configure the signal generator to output a frequency-modulated signal with the following characteristics:

- carrier frequency set to 104.9 MHz
- power level set to 0 dBm
- FM deviation set to 75 kHz
- FM rate set to 10 kHz

Setting the Carrier Frequency

- 1. Press Preset.** This sets the signal generator to its factory-defined instrument state.
- 2. Press Frequency.** Frequency becomes the active function and the preset value for frequency is displayed in the active entry area.
- 3. Enter 104.9 using the numeric keypad and press the MHz softkey.** The new carrier frequency (104.900 000 00 MHz) is shown in both the FREQUENCY area and the active entry area of the display.

Setting the Power Level

- 1. Press Amplitude.** Amplitude becomes the active function and the preset value for amplitude is displayed in the active entry area.
- 2. Enter 0 using the numeric keypad and press the dBm softkey.** The new power level (0.00 dBm) is shown in both the AMPLITUDE area and the active entry area of the display.

Setting the FM Deviation

1. Press **FM/φM**.
The first level menu of FM softkeys is displayed.
2. Press the **FM Dev** softkey.
FM deviation becomes the active function and the preset value for FM deviation is displayed in the active entry area.
3. Enter **75** using the numeric keypad and press the **kHz** softkey.
The new FM deviation is displayed below the **FM Dev** softkey. You should see 75 . 0000 kHz in the second line of the softkey label.

Setting the FM Rate

1. Press the **FM Rate** softkey.
FM rate becomes the active function and the preset value for FM rate is displayed in the active entry area.
2. Enter **10** using the numeric keypad and press the **kHz** softkey.
The new FM rate is displayed below the **FM Rate** softkey. You should see 10 . 0000 kHz in the second line of the softkey label.

Turning On Frequency Modulation

The signal generator is now configured to output a 0 dBm, frequency-modulated carrier at 104.9 MHz with the FM deviation set to 75 kHz and the FM rate set to 10 kHz. The shape of the waveform is a sinewave.

NOTE *Sine* is the default selection for the **FM Waveform** softkey. Press **More (1 of 2)** to see the softkey.

Follow these remaining steps to output the frequency-modulated signal:

1. Press the **FM Off On** softkey.
FM toggles from **Off** to **On**. Notice, also, that the FM display annunciator is turned on, indicating that you have enabled frequency modulation.
2. Press **RF On/Off**.
Notice that the display annunciator changes from **RF OFF** to **RF ON**. The modulated signal is now available at the **RF OUTPUT** connector.

Creating a Step Sweep and a List Sweep

This section will show you two ways to set up the signal generator to sweep a defined set of points. You will create a ten-point step sweep with the settings listed below, then use these points as the basis for a new list sweep.

- frequency range from 525 MHz to 600 MHz
- power level from -20 dBm to 0 dBm
- dwell time 500 ms at each point

Configuring a Step Sweep

- 1. Press Preset.** This sets the signal generator to its factory-defined instrument state.
- 2. Press Sweep/List.** The first level of sweep softkeys is displayed.
- 3. Press the Sweep Type List Step softkey.** This toggles the **Sweep Type List Step** softkey from **List** to **Step**.
- 4. Press the Configure Step Sweep softkey.** Another menu is displayed with softkeys that you will use to create the sweep points.
- 5. Press the Freq Start softkey.** Enter **525** using the numeric keypad and press the **MHz** softkey. This sets the new start frequency for the step sweep to 525 MHz.
- 6. Press the Freq Stop softkey.** Enter **600** using the numeric keypad and press the **MHz** softkey. This sets the new stop frequency for the step sweep to 600 MHz.
- 7. Press the Ampl Start softkey.** Enter **-20** using the numeric keypad and press the **dBm** softkey. This sets the power level for the start of the step sweep to -20 dBm.

Creating a Step Sweep and a List Sweep

- 8.** Press the **Ampl Stop** softkey. Enter **0** using the numeric keypad and press the **dBm** softkey.

This sets the new power level for the end of the step sweep to 0 dBm.
- 9.** Press the **# Points** softkey. Enter **10** by rotating the front panel knob until the number **10** is displayed.

This sets the number of points in the step sweep.
- 10.** Press the **Step Dwell** softkey. Enter **500** using the numeric keypad and pressing the **msec** softkey.

This sets the dwell time for each point in the step sweep.

Turning On Continuous Step Sweep

- 1.** Press **Return**.

This moves the softkey menu up one level.
- 2.** Press the **Sweep** softkey.

Another menu is displayed, showing you choices for sweeping either the frequency, amplitude, or frequency and amplitude data.
- 3.** Press the **Freq & Ampl** softkey.

Selecting this softkey returns you to the previous menu and turns the sweep function on.
- 4.** Press the **Sweep Repeat Single Cont** softkey.

This toggles the **Sweep Repeat Single Cont** softkey from **Single** to **Cont** (Continuous). Notice that the **SWEEP** display annunciator is turned on, indicating that the signal generator is sweeping.
- 5.** Press **RF On/Off**.

Notice that the display annunciator changes from **RF OFF** to **RF ON**. The swept RF signal is now available at the **RF OUTPUT** connector.

Configuring a List Sweep Using Step Sweep Data

1. Press the **Sweep Type List Step** softkey.

This toggles the **Sweep Type List Step** softkey from **Step** to **List**.
2. Press the **Configure List Sweep** softkey.

Another menu is displayed with softkeys that you will use to create the sweep points. Notice that the display shows the current list data. (When no list has been previously created, the default is one point set to the signal generator's maximum frequency, -135 dBm, with a dwell time of 2 ms.)
3. Press the following softkeys:
More (1 of 2) >
Load List From Step Sweep >
Confirm Load From Step Sweep.

The points you defined in the step sweep are automatically loaded into the list.
4. Press the **More (2 of 2)** softkey.

This softkey menu along with the numeric keypad, arrow keys, and front panel knob can be used to edit the sweep points in the list. For more information about editing sweep points, refer to Chapter 2, "Using Functions," of the *ESG Family Signal Generators User's Guide*.

Turning On List Sweep for a Single Sweep

- 1. Press Return.** This moves the softkey menu up one level. Notice that the **Sweep** softkey is still set to sweep both frequency and amplitude data.
- 2. Press the Sweep Repeat Single Cont softkey.** This toggles the **Sweep Repeat Single Cont** softkey from **Cont** to **Single**. Notice that the *SWEEP* display annunciator is turned off.
- 3. Press the Single Sweep softkey.** The signal generator sweeps the points in your list once. Notice that the *SWEEP* display annunciator is turned on during the sweep.
- 4. Press the More (1 of 2) and Sweep Trigger softkeys.** A menu is displayed showing you choices for triggering a sweep. Notice that you had used the default setting, **Immediate**, when you triggered the single sweep in the previous step.
- 5. Press the Trigger Key softkey.** This sets **Sweep Trigger** to **Trigger Key** and returns you to the previous softkey menu.
- 6. Press the More (2 of 2) and Single Sweep softkeys.** This arms the sweep so that it is ready for triggering. Notice that the *ARMED* display annunciator is now turned on.
- 7. Press Trigger.** The signal generator sweeps the points in your list once and the *SWEEP* display annunciator appears during the sweep.

Saving and Recalling an Instrument State

Using this procedure, you will learn how to save instrument settings to a memory register and to recall the settings.

Creating an Instrument State

- 1. Press Preset.** This sets the signal generator to its factory-defined instrument state.
- 2. Press Frequency.** Frequency becomes the active function and the preset value for frequency is displayed in the active entry area.
- 3. Enter 800 using the numeric keypad and press the MHz softkey.** The new carrier frequency (800.000 000 00 MHz) is shown in both the FREQUENCY area and the active entry area of the display.
- 4. Press Amplitude.** Amplitude becomes the active function, and the preset value for amplitude is displayed in the active entry area.
- 5. Enter 0 using the numeric keypad and press the dBm softkey.** The new power level (0.00 dBm) is shown in both the AMPLITUDE area and the active entry area of the display.
- 6. Press AM followed by the AM Off On softkey.** AM toggles from **Off** to **On**. Notice also that the AM display annunciator is turned on, indicating that you have enabled amplitude modulation. You have now created an example instrument state that you will save and recall.

Saving an Instrument State

- 1. Press **Save** followed by the **Select Seq** softkey.**

The sequence number becomes the active function. The signal generator displays the last sequence that you have used.
- 2. Enter 1 using the numeric keypad and press the **Enter** softkey.**

This sets the sequence number to 1. (You can also use the arrow keys to enter the sequence number.)
- 3. Press the **Select Reg** softkey.**

The register number in sequence 1 becomes the active function. The signal generator either displays the last register used [accompanied by the text: (in use)] or, if no registers are in use, displays register 00 [accompanied by the text: (available)].
- 4. Enter 1 using the numeric keypad and press the **Select Reg** softkey.**

This selects register 01. (You can also use the arrow keys to select the register number.)
- 5. Press the **SAVE Seq[1] Reg[01]** softkey.**

The current instrument settings, including the frequency, amplitude, and modulation changes you made, have been stored in the signal generator memory.

Recalling an Instrument State

- 1. Press **Preset**.**

This sets the signal generator to its factory-defined instrument state.
- 2. Press **Recall**.**

Notice that the **Select Seq** softkey shows sequence 1. (This is the last sequence that you used.) You do not need to change the sequence.
- 3. Press the **RECALL Reg** softkey.**

The register to be recalled in sequence 1 becomes the active function.
- 4. Enter 1 using the numeric keypad and press the **Enter** softkey.**

Notice that your stored instrument settings have been immediately recalled. (You can also use the arrow keys to select the register number.)

Setting Up a Digital Modulation in the GSM Format

NOTE You must have an ESG-D or ESG-DP Series Signal Generator with Option UN8 to perform this procedure.

Using this procedure you will set up the signal generator to output a GMSK digitally modulated signal in the GSM format with the following characteristics:

- carrier frequency set to 891 MHz
- power level set to -5 dBm
- timeslot 0 activated and configured as a Custom channel
- a fixed 4-bit repeating sequence selected as the data pattern for timeslot 0
- timeslot 7 activated and configured as a Normal channel
- 4 ones and 4 zeros selected as the data pattern for timeslot 7

Setting the Carrier Frequency

- 1. Press Preset.** This sets the signal generator to its factory-defined instrument state.
- 2. Press Frequency.** Frequency becomes the active function and the preset value for frequency is displayed in the active entry area.
- 3. Enter 891 using the numeric keypad and press the MHz softkey.** The new carrier frequency (891.000 000 00 MHz) is shown in both the FREQUENCY area and the active entry area of the display.

Setting the Power Level

- 1. Press Amplitude.** Amplitude becomes the active function and the preset value for amplitude is displayed in the active entry area.
- 2. Enter -5 using the numeric keypad and press the dBm softkey.** The new power level (-5.00 dBm) is shown in both the AMPLITUDE area and the active entry area of the display.

Setting Up a Digital Modulation in the GSM Format

Selecting the Data Format

1. Press **Mode**. Then press the following softkeys:
Real Time I/Q Baseband (if it appears) > **TDMA** > **GSM**.

This selects the GSM communications standard.
2. Press the **Data Format Pattern Framed** softkey.

This toggles the **Data Format Pattern Framed** softkey from **Pattern** to **Framed**. When you select **Framed** for bursting the frame envelope, you will be transmitting framed data. This means that you will be bursting the timeslots that you have activated and there will be no RF carrier during the off timeslots. Notice that **Configure Timeslots** has become an active softkey.

Setting Up Timeslot 0

1. Observe the **GSM Timeslot Pattern** on the display.

Notice that the preset condition for timeslot #0 has the timeslot turned on and configured as a Normal channel.
2. Press the **Configure Timeslots** softkey and observe the softkey menu.

The **Timeslot #** softkey shows that timeslot #0 is selected as the active timeslot. The **Timeslot Off On** softkey shows that timeslot #0 is turned on. Finally, the **Timeslot Type** softkey shows that timeslot #0 is configured as a Normal channel.
3. Press the **Timeslot Type** softkey.

Another menu of softkeys is displayed.
4. Press the **Custom** softkey.

This changes the timeslot type to Custom timeslot and automatically returns you to the previous softkey menu. Notice that the **Timeslot Type** softkey has changed from **Normal** to **Custom**. Also notice that the display shows timeslot #0 configured as a Custom timeslot.
5. Press the **Configure Custom** softkey.

Another menu is displayed showing you data choices for the timeslot's transmission. Notice that the display has changed, showing you a visual representation of the timeslot. Directly below the visual representation of the timeslot, you should see **Data: PN9**. PN9 is the default timeslot transmission data.

6. Press the **FIX4** softkey. This changes the transmitted data to a fixed 4-bit repeating sequence. The default 4-bit repeating sequence of 0000 is shown in the active entry area of the display.
7. Enter **1010** using the numeric keypad and press the **Enter** softkey. This changes the pattern from 0000 to 1010. Directly below the visual representation of the timeslot, you should see `Data: 1010`.

Setting Up Timeslot 7

1. Press **Return**. This moves the softkey menu up one level.
2. Press the **Timeslot #** softkey. Then enter **7** using the numeric keypad and press the **Enter** softkey. This selects timeslot #7 as the active timeslot. (You can also use the arrow keys to select the timeslots.) The current active timeslot (#7) is displayed in the active entry area.
3. Press the **Timeslot Off On** softkey. This toggles the **Timeslot Off On** softkey from **Off** to **On**. Notice that the display now shows that timeslot #7 is turned on.
4. Press the **Timeslot Type** softkey. Another menu of softkeys is displayed.
5. Press the **Normal** softkey. This changes the timeslot type to a Normal timeslot and automatically returns you to the previous softkey menu. Notice that the **Timeslot Type** softkey has changed from **Custom** to **Normal**. Also notice that the display shows timeslot #7 configured as a Normal timeslot.
6. Press the **Configure Normal** softkey. Another menu of softkeys is displayed, allowing you to change the E, S, and TS fields for the Normal timeslot.
7. Press the following softkeys:
E > Other Patterns > 4 1's & 4 0's. This fills the E field with a repeating sequence of four 1's followed by four 0's. Directly below the visual representation of the timeslot, you should see `E: P4`.

Setting Up a Digital Modulation in the GSM Format

Turning On the GSM Format and the Modulation

The signal generator is now configured to burst two uplink timeslots with a -5.0 dBm, GMSK digitally modulated carrier at 891 MHz. Follow these remaining steps to output the framed data.

1. Press **Return** twice.

This moves the softkey menu up two levels. The first GSM softkey menu should be displayed. (The first softkey in this menu is **GSM Off On**.)

2. Press the **GSM Off On** softkey.

This toggles the **GSM Off On** softkey from **Off** to **On**. At this time the internal baseband generator generates the internal data patterns that you have configured for timeslots 0 and 7. A message is displayed while this process is taking place. Notice also that the following display annunciators are turned on:

- **GSM** indicates that you have enabled the GSM standard.
- **I/Q** indicates that I/Q modulation is being generated.
- **ENVLP** indicates that burst is activated for transmitting framed data.

3. Press **RF On/Off**.

Notice that the display annunciator changes from **RF OFF** to **RF ON**. The modulated signal is now available at the **RF OUTPUT** connector.

2 Exploring the User Interface

This chapter provides you with an overview of your signal generator's user interfaces:

- front panel hardkeys and connectors
- display fields and annotations
- rear panel connectors

Front Panel

The following pages describe the numbered items shown in the figure below.

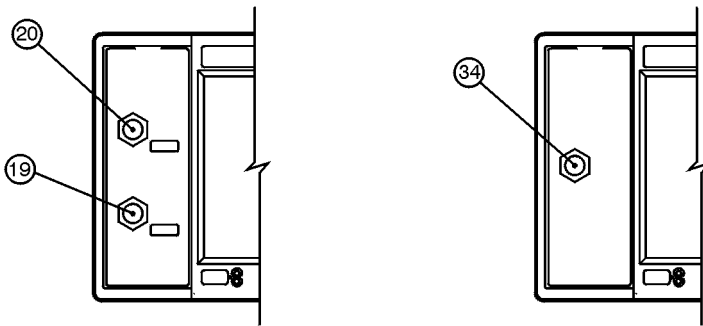
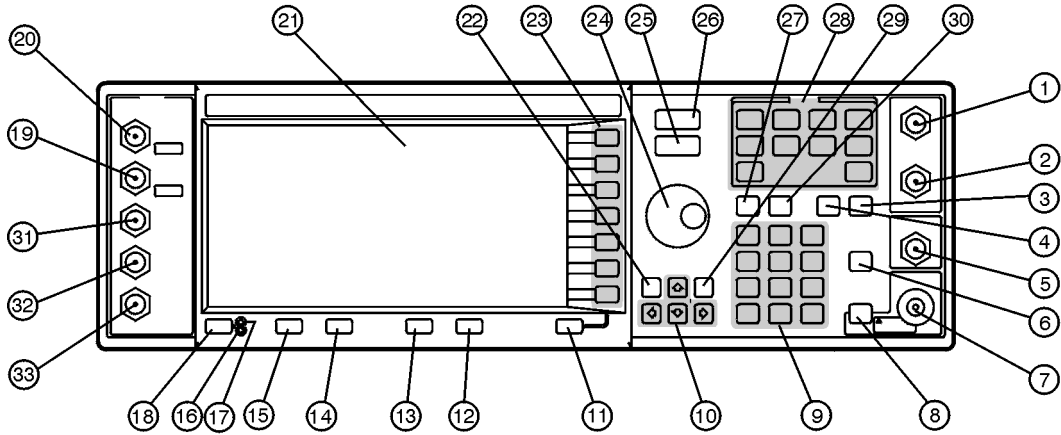

qk78b

1. **EXT 1 INPUT** This female BNC input connector accepts a $1-V_{pk}$ signal for FM, Φ M, and AM.
2. **EXT 2 INPUT** This female BNC input connector accepts a $1-V_{pk}$ signal for FM, Φ M, AM, and pulse modulation.
3. **Help** Press this hardkey for a short textual description of the function of the front panel hardkeys and softkeys. Press this key again and you will be returned to normal instrument operation.
4. **Trigger** Press this hardkey to begin an event (such as a step or list sweep). This key must first be selected as the method for activating an event by pressing the **Trigger Key** softkey, located in the softkey menus associated with the event.
5. **LF OUTPUT** This female BNC connector is the output connector for modulation signals generated by the LF (low frequency) source function generator.
6. **Mod On/Off** This hardkey toggles all modulation signals on and off.
7. **RF OUTPUT** This female Type-N connector is the output connector for RF signals.
8. **RF On/Off** This hardkey toggles the RF signal on and off at the RF OUTPUT connector.
9. **Numeric Keypad** The numeric keypad consists of the digit keys (0 through 9), a decimal point key, and a backspace key. The backspace key has dual functions for both backspacing and changing the sign of a value between positive and negative. Use these keys whenever the active function requires a value input.
10. **Arrow Keys** The up and down arrow keys increase or decrease a numeric value. You can also use these keys to scroll through displayed lists to select items. The left and right arrow keys choose the highlighted digit in the active entry area of the display; that digit can be modified by the up and down arrow keys or the knob. You can also use these keys in a list to select items in a row.

- 11. Return** The **Return** key cancels the current active function and moves you from your current softkey menu to the softkey menu that precedes it.

- 12. Display Contrast Decrease** Press this key and hold it down to cause the display background to darken in comparison to the text on the display.

- 13. Display Contrast Increase** Press this key and hold it down to cause the display background to brighten in comparison to the text on the display.

- 14. Local** Press this key to return the signal generator to local (front panel) control from remote operation.

- 15. Preset** Press this key to set the signal generator to a known state (either the factory-defined state or a user-defined state).

- 16. Standby LED** This yellow LED lights when the instrument is in standby condition. In standby, the power switch is off but the instrument is still connected to the main power circuit by way of the power cord.

- 17. Line Power LED** This green LED lights when power is cycled on to the signal generator.

- 18. Power Switch** Press this hardkey to turn power to the signal generator either on (green LED on) or to standby (yellow LED on).

- 19. Q INPUT** This connector accepts an externally supplied, analog, quadrature-phase component of I/Q modulation. This female BNC connector is provided only on ESG-D and ESG-DP Series Signal Generators.

- 20. I INPUT** This connector accepts an externally supplied, analog, in-phase component of I/Q modulation. This female BNC connector is provided only on ESG-D and ESG-DP Series Signal Generators.

- 21. Display** The LCD display provides information on the current instrument state such as modulation status, frequency and amplitude settings, status indicators, and error messages. Softkey labels corresponding to their adjacent keys are located on the right-hand side of the display.
- 22. Hold** Press this hardkey to deactivate the currently active function and blank the softkey menu. Once Hold is pressed, the front panel knob, the arrow keys, and the numeric keypad have no effect. To return to normal operation, press a function or menu hardkey.
- 23. Softkeys** Press a softkey to activate the function indicated by the corresponding label on the display.
- 24. Knob** The knob increases or decreases a numeric value. Any of the values that can be set through the numeric keypad or the step keys can also be set with the knob.
- 25. Amplitude** Press this hardkey to activate the power level amplitude function so that you can change the amplitude of the RF output.
- 26. Frequency** Press this hardkey to activate the frequency function so that you can change the frequency of the RF output.
- 27. Save** This hardkey lets you save up to 100 different instrument states in a combination of 100 memory registers and 10 register sequences. The number of states you can save, however, is limited by the size of whatever else is stored in the file system.
- 28. Menu Keys** These hardkeys provide access to the signal generator's primary functionality. Press these keys for access to softkey menus where you can configure modulations, step and list sweeps, and various frequency and power capabilities.
- 29. Incr Set** Press this hardkey to toggle between the current active function and the increment size for that function. With increment size selected, you can change the current increment value.

- 30. Recall** This hardkey lets you restore any instrument state that you previously saved in a memory register. You can save up to 100 different instrument states in a combination of 100 memory registers and 10 register sequences. The number of states you can save, however, is limited by the size of whatever else is stored in the file system.
- 31. DATA Input** The TTL/CMOS-compatible DATA connector accepts an externally supplied data input for digital modulation applications. This female BNC connector is provided only on instruments with Option UN8.
- 32. DATA CLOCK Input** The TTL/CMOS-compatible DATA CLOCK connector accepts an externally supplied data-clock input for digital modulation applications. This female BNC connector is provided only on instruments with Option UN8.
- 33. SYMBOL SYNC Input** The CMOS-compatible SYMBOL SYNC connector accepts the digital-modulation symbol synchronization signal from an external source. This female BNC connector is provided only on instruments with Option UN8.
- 34. PULSE IN** This connector accepts an externally supplied TTL-compatible pulse signal. The pulse signal is activated with the **Fast Pulse Off On** softkey or via SCPI command. The maximum input for this connector is ± 15 volts. This female BNC connector is provided only on instruments with Option 1E6.

Display

The following pages describe the numbered items shown in the figure below.

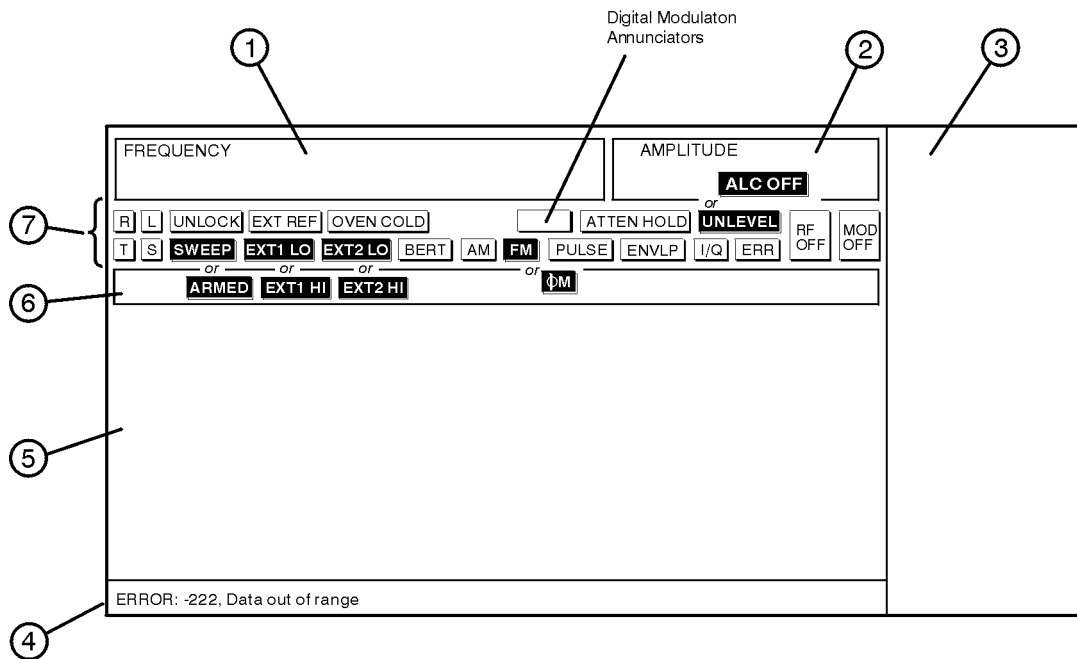

qk79b

- | | |
|--|--|
| <ol style="list-style-type: none"> 1. Frequency Area 2. Amplitude Area 3. Softkey Labels | <p>The current CW frequency setting is shown in this portion of the display.</p> <p>The current output power level setting is shown in this portion of the display.</p> <p>These labels define the function of the corresponding softkeys immediately to the right of the label.</p> |
|--|--|

- 4. Error Messages Area** Abbreviated error messages are reported in this space. When multiple error messages occur, only the most recent message remains displayed. All of the reported error messages with details can be viewed by pressing **Utility > Error Info > View Next Error Message**.
- 5. Text Area** This area is used to display status information about the signal generator such as the modulation status, to enter information such as creating sweep lists, and to manage information such as displaying the catalog of files and deleting unwanted files.
- 6. Active Entry Area** The current active function is shown in this area. For example, if frequency is the active function, the current setting will be displayed in the active entry area and that setting will change as you enter a new value.
- 7. Annunciators** The display annunciators show the status of some of the signal generator functions and indicate error conditions of the instrument. The following annunciators are available:

 - ϕ M This annunciator appears when phase modulation is turned on.
 - ALC OFF This annunciator appears when the automatic leveling control (ALC) circuit is disabled.
 - AM This annunciator appears when amplitude modulation is turned on.
 - ARMED This annunciator appears when a sweep has been initiated and the signal generator is waiting for the sweep trigger event.
 - ATTEN HOLD This annunciator appears when the attenuator hold function is turned on. When this function is on, the attenuator is frozen at its current setting.
 - BERT This annunciator appears whenever the Option UN7, bit error rate test (BERT), or Option 300, base station BERT extension, functions are turned on.
 - Digital Modulation Annunciators** An annunciator appears here when a digital modulation is on. The exact annunciator depends on the modulation type, and is documented in the manual that addresses that modulation. Only one modulation can be on at a time, so sharing an annunciator location is not a problem.

ENVLP	This annunciator appears if the burst envelope modulation is turned on. This annunciator is present only on ESG-D and ESG-DP Series Signal Generators.
ERR	This annunciator appears when an error message is placed in the error queue. This annunciator will not turn off until you have either viewed all of the error messages or cleared the error queue. You can view and delete error messages using the Utility menu.
EXT1 LO/HI	This annunciator toggles between EXT1 LO and EXT1 HI. This annunciator appears if the AC-coupled signal to the EXT 1 input is less than $0.97 V_{pk}$ or greater than $1.03 V_{pk}$.
EXT2 LO/HI	This annunciator toggles between EXT2 LO and EXT2 HI. This annunciator appears if the AC-coupled signal to the EXT 2 input is less than $0.97 V_{pk}$ or greater than $1.03 V_{pk}$.
EXT REF	This annunciator appears when an external 1, 2, 5, or 10 MHz frequency reference is in use.
FM	This annunciator appears when frequency modulation is turned on.
I/Q	This annunciator appears when I/Q modulation is turned on. This annunciator is present only on ESG-D and ESG-DP Series Signal Generators.
L	The L annunciator is turned on when the signal generator is in the listen mode and is receiving information or commands over the GPIB or RS-232.
MOD OFF	This annunciator toggles between MOD OFF and MOD ON and is always visible in the display. This annunciator indicates whether the modulations that you have enabled are modulating the RF carrier.
OVEN COLD	This annunciator appears when the temperature of the internal ovenized reference oscillator (ESG-AP, ESG-DP, and Option 1E5) has dropped below an acceptable level.
PULSE	This annunciator appears when pulse modulation is turned on.
R	The R annunciator appears when the signal generator is in remote GPIB operation.

RF OFF	This annunciator toggles between RF OFF and RF ON and is always visible in the display. This annunciator indicates whether the RF signal is present at the RF OUTPUT connector.
S	The S annunciator appears when the signal generator has generated a service request (SRQ) over the GPIB.
SWEEP	This annunciator appears when the signal generator is sweeping in list or step mode.
T	The T annunciator appears when the signal generator is in the talk mode and is transmitting information over the GPIB or RS-232.

Rear Panel

The following pages describe the numbered items shown in the figure below.

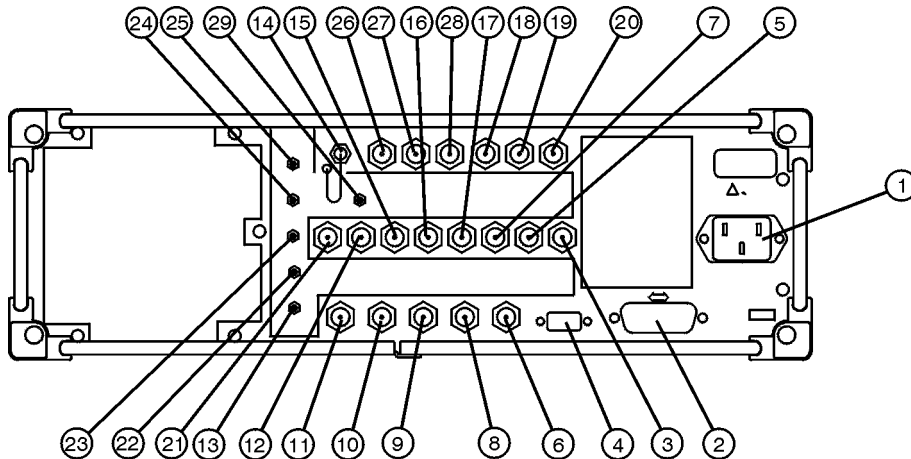

qk76b

- 1. AC Power Receptacle** The power cord receptacle accepts a three-pronged cable that is shipped with the instrument. The line voltage is connected here.
- 2. GPIB** The GPIB connector allows communications with compatible devices such as external controllers. It is functionally equivalent to the AUXILIARY INTERFACE connector.
- 3. SYMBOL SYNC OUT** The TTL/CMOS-compatible SYMBOL SYNC OUT connector outputs a symbol synchronization pulse, one data-clock period wide, for use in digital modulation applications. This female BNC connector is present only on instruments with Options UND or UN8. With Option 201 you can select from several different output signals for this connector.

- 4. AUXILIARY INTERFACE** This male DB-9 connector is an RS-232 serial port that can be used for controlling the signal generator remotely. It is functionally equivalent to the GPIB connector.
- 5. DATA CLK OUT** The TTL/CMOS-compatible DATA CLK OUT connector outputs a clock signal for digital modulation data. This female BNC connector is present only on instruments with Options UND or UN8. With Option 201 you can select from several different output signals for this connector
- 6. SWEEP OUT** This female BNC connector provides a voltage range of 0 to +10 V. When the signal generator is sweeping, the SWEEP OUT signal ranges from 0 V at the beginning of the sweep to +10 V at the end of the sweep regardless of the sweep width.
- 7. DATA OUT** The TTL/CMOS-compatible DATA OUT connector outputs digital modulation data sourced from an externally supplied signal at the DATA input or from the internal pattern generator. This female BNC connector is present only on instruments with Options UND or UN8. With Option 201 you can select from several different output signals for this connector.
- 8. TRIGGER OUT** This female BNC connector outputs a TTL signal that is asserted high at the start of a dwell sequence, or at the start of waiting for the point trigger in manual sweep mode, and low when the dwell is over, or when the point trigger is received, or once per sweep during an LF sweep.
- 9. TRIGGER IN** This female BNC connector accepts a TTL signal for triggering, such as point-to-point in manual sweep mode or an LF sweep in external sweep mode.
- 10. 10 MHz IN** This female BNC connector accepts a -3.5 to +20 dBm signal from an external timebase reference that is within 10 ppm (standard timebase) or 1 ppm (high stability timebase).
- 11. 10 MHz OUT** This female BNC connector provides a nominal signal level of +7 dBm \pm 2 dB, and an output impedance of 50 Ω . The accuracy is determined by the timebase used.

- 12. PATTERN TRIG IN** This input can accept either a TTL/CMOS low to TTL/CMOS high or TTL/CMOS high to TTL/CMOS low edge trigger. With Option UN8 this input triggers the internal digital modulation pattern generator to start a single pattern output or to stop and re-synchronize a pattern that is being continuously output. With Option UND this input is the external trigger source for all ARB waveform generator triggers. With Option 201 this connector is used for system reset trigger input.
- 13. BURST GATE IN** The BURST GATE IN connector accepts a TTL or CMOS signal for gating burst power in digital modulation applications. This female BNC connector is present only on instruments with Options UND or UN8. With Option 201 this connector is used for even second synchronization input.
- 14. COHERENT CARRIER OUT** This connector outputs RF that is not modulated with AM, pulse, or I/Q modulation, but that is modulated with FM or Φ M. This SMA connector is present only on ESG-D and ESG-DP Series Signal Generators.
- 15. ALT PWR IN** This BNC connector accepts a CMOS signal for synchronization of external data and alternate power signal timing. This connector is active only with Options UNA or 201. With Option 201 this connector is used for Long Code State Latch strobe input.
- 16. EVENT 1** With Option UN8 turned on, this TTL/CMOS-compatible connector outputs a pulse that can be used to trigger the start of a data pattern, frame, or timeslot. With Option UN5 turned on, an even second output is generated every two seconds indicating the beginning of each short code sequence. With Option UND turned on, a marker is output whenever a Marker 1 is turned on in the waveform. With Option 201 you can select from several different output signals for this connector.
- 17. EVENT 2** This TTL/CMOS-compatible connector outputs a data enable signal for gating external equipment. With Option UN5 turned on, a marker is output every 26.67 ms, corresponding to the start of each short code. With Option UND turned on, a marker is output whenever a Marker 2 is turned on in the waveform. With Option 201 this connector is used for system reset output.

- 18. BASEBAND GEN REF IN** With Option UN8 enabled, the BASEBAND GEN REF IN connector accepts a 0 to +20 dBm sinewave or TTL squarewave signal from an external 13-MHz timebase reference. This female BNC connector is present only on instruments with Options UND or UN8.
- 19. I OUT** The I OUT connector outputs the analog, in-phase component of I/Q modulation from the internal baseband generator. This female BNC connector is present only on instruments with Options UND or UN8.
- 20. Q OUT** The Q OUT connector outputs the analog, quadrature-phase component of I/Q modulation from the internal baseband generator. This female BNC connector is present only on instruments with Options UND or UN8.
- 21. BER MEAS END** The BER MEAS END connector outputs a signal that indicates the status of the bit-error-rate (BER) measurements. This female SMB connector is present only on instruments with Option UN7.
- 22. BER TEST OUT** The BER TEST OUT connector outputs a signal that indicates the test result of the pass/fail judgement of the bit-error-rate measurements. This female SMB connector is present only on instruments with Option UN7.
- 23. BER ERR OUT** The output of the BER ERR OUT connector is normally low. When the maximum data rate mode is set to 2 Mbps, the BER ERR OUT connector outputs pulse signals that indicate errors. This female SMB connector is present only on instruments with Option UN7.
- 24. BER NO DATA** The BER NO DATA connector outputs a signal that indicates the “no data” status. The no data status is reported when there has been no clock input for more than 3 seconds or there has been no data change for more than 200 bits. This female SMB connector is present only on instruments with Option UN7.
- 25. BER SYNC LOSS** The BER SYNC LOSS connector outputs a signal that indicates the synchronization loss state. This female SMB connector is present only on instruments with Option UN7.

- 26. BER DATA IN** Use this connector to input the data streams for the bit-error-rate measurements. This female BNC connector is present only on instruments with Option UN7.
- 27. BER CLK IN** Use this connector to input the clock signal for the bit-error-rate measurements. This female BNC connector is present only on instruments with Option UN7.
- 28. BER GATE IN** Use this connector to input the clock gate signal for the bit-error-rate measurements. The connector can be enabled or disabled by a softkey or an GPIB command. This female BNC connector is present only on instruments with Option UN7.
- 29. 321.4 MHz IN** Use this connector to input a downconverted 321.4 MHz GSM signal for base transceiver station (BTS) loopback measurements. This female SMB connector is present only on instruments with Option 300.