

Agilent Technologies

8481A/8482A/8483A Power Sensor

Operating and Service Manual

Serial Numbers:

This manual applies directly to instruments with serial number prefixes:

8481A: 3318A, US3729 and above

8482A: 3318A, US3729 and above

8483A: 3318A, US3729 and above

With the changes described in Appendix A, this manual also applies to instruments with serial numbers prefixed:

8481A: 1550A, 1926A, 2237A, 2349A, 2552A, 2702A

8482A: 1551A, 1925A, 2237A, 2349A, 2607A, 2652A

8483A: 1602A, 1925A, 2243A, 2329A, 2351A, 2405A, 2623A, 2701A

For additional important information about serial numbers, see "Instruments Covered By Manual."



Part No. 08481-90049

Printed in USA

August 2001

Supersedes August 1997

Notice

The information contained in this document is subject to change without notice.

Agilent Technologies makes no warranty of any kind with regard to this material, including but not limited to, the implied warranties of merchantability and fitness for a particular purpose. Agilent Technologies shall not be liable for errors contained herein or for incidental or consequential damages in connection with the furnishing, performance, or use of this material.

© Copyright Agilent Technologies 1975, 1979, 1986, 1990, 1993, 1997, 2001

All Rights Reserved. Reproduction, adaptation, or translation without prior written permission is prohibited, except as allowed under the copyright laws.

1400 Fountaingrove Parkway, Santa Rosa CA, 95403-1799, USA

Warranty

A copy of the specific warranty terms applicable to your Agilent Technologies product and replacement parts can be obtained from your local Sales and Service Office.

Herstellerbescheinigung

Hiermit wird bescheinigt, daß dieses Gerät/System in Übereinstimmung mit den Bestimmungen von Postverfügung 1046/84 funktentstört ist.

Der Deutschen Bundespost wurde das Inverkehrbringen dieses Gerätes/System angezeigt und die Berechtigung zur Überprüfung der Serie auf Einhaltung der Bestimmungen eingeräumt.

Zusatzinformation für Meß- und Testgeräte:

Werden Meß- und Testgeräte mit ungeschirmten Kabeln und/oder in offenen Meßaufbauten verwendet so ist vom Betreiber sicherzustellen, daß die Funkentstörtbedingungen unter Betriebsbedingungen an seiner Grundstücksgrenze eingehalten werden.

Manufacturer's Declaration

This is to certify that this equipment is in accordance with the Radio Interference Requirements of Directive FTZ 1046/1984. The German Bundespost was notified that this equipment was put into circulation, and has been granted the right to check the equipment type for compliance with these requirements.

Note: If test and measurement equipment is operated with unshielded cables and/or used for measurements in open setups, the user must ensure that under these operating conditions, the radio frequency interference limits are met at the border of his premises.

Contents

1. General Information	
General Information	1-1
Instruments Covered by Manual	1-1
Description	1-2
Option 001 (8481A Only)	1-2
Accessories Supplied	1-2
Recommended Calibration Interval	1-3
Recommended Test Equipment	1-6
Installation	1-6
Initial Inspection	1-6
Storage and Shipment	1-6
Environment	1-6
Original Packaging	1-6
Interconnections	1-7
Operation	1-7
Environment	1-7
Operating Precautions	1-7
Operating Procedures	1-7
SWR (Reflection Coefficient) Performance Test	1-8
FET Balance Adjustment	1-8
Equipment	1-8
Replaceable Parts	1-10
Service	1-16
Principles of Operation	1-16
Troubleshooting	1-17
Power Meter	1-17
Power Sensor	1-18
A2 Input Amplifier Assembly	1-18
Repair	1-18
Repair Strategy	1-18
Bulkhead	1-18
A2 Input Amplifier Assembly Printed Circuit	1-19
Bulkhead Replacement	1-19
Procedure	1-19
Bulkhead Repair	1-19
Equipment	1-19
Rebuilding the Bulkhead	1-19
Cartridge Replacement	1-21
Connector Cleaning	1-23
Disassembly Procedure	1-25
Reassembly Procedures	1-26

A. MANUAL CHANGES	
CHANGE INSTRUCTIONS	A-2
CHANGE A	A-2
CHANGE B	A-2
CHANGE D	A-3
CHANGE E	A-3
CHANGE F	A-3
CHANGE G	A-3
CHANGE H	A-3
CHANGE I	A-3

General Information

General Information

This Operating and Service Manual contains information about initial inspection, performance tests, adjustments, operation, troubleshooting and repair of the Agilent 8481A, 8482A, and 8483A Power Sensors.

Instruments Covered by Manual

A serial number label is attached to the rear of the power sensor. This label has two instrument identification entries: the first provides the instrument's serial number and the second provides the identification number for each option built into the instrument.

The serial number has two parts: the prefix (two letters and the first four numbers), and the suffix (the last four numbers). Refer to Example Serial Number below.



sz155e

Example Serial Number

The two letters identify the country in which the unit was manufactured. “US” represents the USA and “MY” represents Malaysia. The four numbers of the prefix are a code identifying the date of the last major design change incorporated in your power sensor. The four digit suffix is a sequential number and, coupled with the prefix, provides a unique identification for each unit produced. Whenever you list the serial number or refer to it in obtaining information about your power sensor, be sure to use the complete number, including the full prefix and the suffix.

For information concerning a serial number prefix not listed on the title page, contact your nearest Agilent Technologies Sales and Service office.

Description The Power Sensors are used for measuring the average power supplied by an RF source. In use, the Power Sensor is connected to the RF source and to a compatible power meter. (Suitable meters are the 435B, 436A, 437B, 438A, E4416A, E4417A, E4418A/B, or E4419A/B Power Meter.) The 8481A and 8482A Power Sensors place a 50Ω load on the RF source (8483A has a 75Ω load). The power meter indicates the power dissipated in this load in μW (or mW) and dBm.

The Power Sensors measure power levels from -30 dBm to $+20$ dBm ($1 \mu\text{W}$ to 100 mW), at frequencies from 10 MHz to 18 GHz (8481A), or 100 kHz to 4.2 GHz (8482A), or 100 kHz to 2 GHz (8483A).

The physical configuration of all sensors is the same. However, because of the different frequency ranges covered, there are some changes in part numbers and component values.

CAL FACTOR data is provided on a label attached to the Power Sensor's cover. Maximum uncertainties of the CAL FACTOR data are listed in table 1.

Specifications for the Power Sensor are provided in table 2.

**Option 001
(8481A Only)**

A precision 7 mm RF connector (APC-7) is substituted for the type-N connector.

Accessories Supplied

The 8483A is supplied with an adapter (1250-0597, shown in figure 1) for joining the Power Sensor's 75Ω type N connector to the 50Ω power reference connector on the power meter. This accessory is a mechanical adapter only, not an impedance transformer. Therefore, an impedance mismatch exists that must be taken into consideration when calibrating the power meter and power sensor. The REF CAL FACTOR, on the power sensor label, has been adjusted for the impedance mismatch. This REF CAL FACTOR, when used to calibrate any power meter, will allow calibration to 1.000 mW. The CAL FACTOR, from the data on the power sensor label, should be used for any power measurements in a 75Ω system at 50 MHz.

Caution

Remove mechanical adapter from the Power Sensor before connecting the sensor to a 75Ω source.

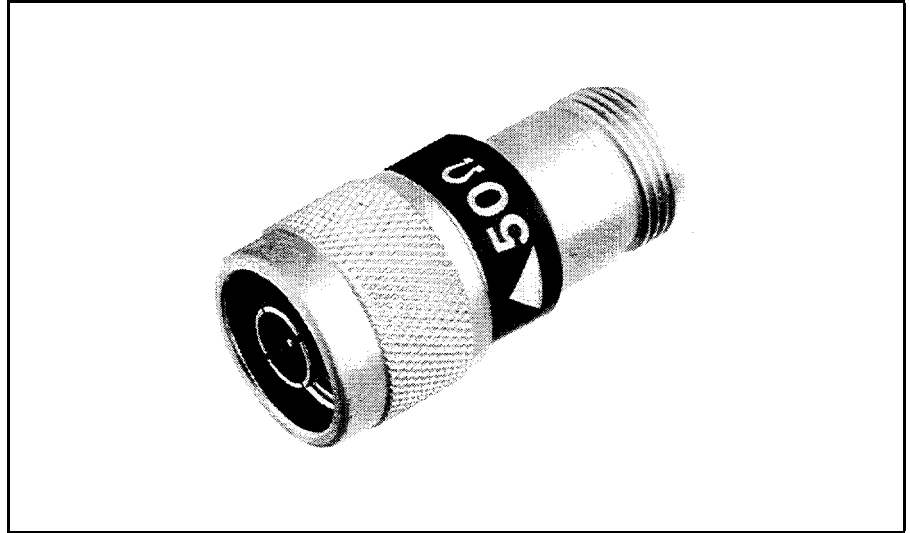

Figure 1. Mechanical Adapter (8483A Only)

**Recommended
Calibration Interval**

Agilent Technologies recommends a one year calibration cycle for the 8481A/82A/83A power sensors.

Table 1. Uncertainty of Calibration Factor Data³

Frequency (MHz)	Sum of Uncertainties $\pm(\%)^1$	Probable Uncertainties $\pm(\%)^2$	Frequency (MHz)	Sum of Uncertainties $\pm(\%)^1$	Probable Uncertainties $\pm(\%)^2$
8481A			8482A (cont.)		
10.0	2.5	1.3	3.0	2.2	1.2
30.0	2.6	1.4	10.0	2.5	1.3
100.0	3.1	1.6	30.0	2.6	1.4
300.0	3.1	1.6	100.0	3.1	1.6
(GHz)			300.0	3.1	1.6
1.0	2.7	1.4	1000.0	2.7	1.4
2.0	2.7	1.4	2000.0	2.7	1.4
4.0	2.8	1.5	4000.0	2.8	1.5
6.0	2.8	1.5	8483A		
8.0	3.2	1.7	(MHz)		
10.0	3.6	1.9	0.1	2.6	1.5
12.4	4.4	2.3	0.3	2.5	1.4
14.0	4.8	2.6	1.0	2.5	1.4
16.0	5.2	2.9	3.0	2.5	1.4
18.0	5.8	3.2	10.0	3.0	1.3
8482A			30.0	3.1	1.6
(MHz)			100.0	3.9	2.0
0.1	2.3	1.3	300.0	3.9	2.0
0.3	2.2	1.2	1000.0	3.7	2.0
1.0	2.2	1.2	2000.0	3.7	2.0

1 Includes uncertainty of reference standard and transfer uncertainty. Directly traceable to NIST (National Institute of Standards Technology).

2 Square root of the sum of the individual uncertainties squared (RSS).

3 Uncertainties are for sensors with type N connectors. Values will be slightly less for sensors with APC-7 connectors.

Table 2. Specifications

8481A	
Power Range: -30 dBm to +20 dBm (1 μ W — 100 mW)	
Frequency Range: 10 MHz — 18 GHz	
Nominal Impedance: 50 Ω	
Maximum SWR (Reflection Coefficient):	10 MHz to 30 MHz <1.4 (0.166) 30 MHz to 50 MHz <1.18 (0.083) 50 MHz to 2 GHz <1.10 (0.048) 2 GHz to 12.4 GHz <1.18 to 0.083) 12.4 GHz to 18 GHz <1.28 (0.123)
Maximum Power: 300 mW Average	
Maximum Peak Power: 15W Peak	
Maximum Energy/Pulse: 30W \cdot μ s	
RF Connector: Type N Male	
8482A	
Power Range: -30 dBm to +20 dBm (1 μ W — 100 mW)	
Frequency Range: 100 kHz — 4.2 GHz	
Nominal Impedance: 50 Ω	
Maximum SWR (Reflection Coefficient):	100 kHz to 300 kHz <1.60 (0.231) 300 kHz to 1 MHz <1.20 (0.091) 1 MHz to 2 GHz <1.10 (0.048) 2 GHz to 4.2 GHz <1.30 to 0.130)
Maximum Power: 300 mW Average	
Maximum Peak Power: 15W Peak	
Maximum Energy/Pulse: 30W \cdot μ s	
RF Connector: Type N Male	
8483A	
Power Range: -30 dBm to +20 dBm (1 μ W — 100 mW)	
Frequency Range: 100 kHz — 2 GHz	
Nominal Impedance: 75 Ω	
Maximum SWR (Reflection Coefficient):	100 kHz to 600 kHz <1.80 (0.286) 600 kHz to 2 GHz <1.18 (0.083)
Maximum Power: 300 mW Average	
Maximum Peak Power: 10W Peak	
Maximum Energy/Pulse: 30W \cdot μ s	
RF Connector: Type N Male (75 Ω)	
Dimensions, Including RF Connector: 30 mm wide, 38 mm high, 105 mm long (1 3/16 in. x 1 1/2 in. x 5 7/8 in.)	
Weight: Net, 0.2 kg (8 oz)	

Note

When operating in the top 10 dB input power range (e.g. +10 to +20 dBm), an error due to deviation from square law operation may occur. This possible error, which applies to the 8481A, 8482A, and 8483A, is expressed as follows:

Worst Case Power Linearity:

+2/-4% (+10 to +20 dBm input range)

+/-3% for EPM Power Meters (+10 to +20 dBm input)

Negligible (-30 to +10 dBm input range)

Recommended Test Equipment

Table 3 lists the test equipment recommended to check, adjust, and troubleshoot the Power Sensor. If substitute equipment is used, it must meet or exceed the critical specifications.

Table 3. Recommended Test Equipment

Instrument Type	Critical Specifications	Suggested Model	Use ¹
Digital Voltmeter	Range: 100 mVdc to 100 Vdc Input Impedance: 100 mΩ Resolution: 4-digit Accuracy: ±0.05% ±1 digit	3466A or 34401A	T
Oscilloscope	Bandwidth: dc to 50 MHz Sensitivity: Vertical, 0.2 V/div Horizontal, 1 ms/div	1741A, 1980B or 54622A	A,T
Ohmmeter	Range: 1 — 100,000Ω Accuracy: ±5%	3466A or 34401A	T
DC Power Supply	Range: 5 to 15 Vdc	6214B or E3610A	T

¹ A = Adjustment, T = Troubleshooting

Installation

Initial Inspection

Inspect the shipping container. If the container or packing material is damaged, it should be kept until the contents of the shipment have been checked mechanically and electrically. If there is mechanical damage or if the instrument does not pass the performance tests, notify the nearest Agilent Technologies office. Keep the damaged shipping materials (if any) for inspection by the carrier and an Agilent Technologies representative.

Storage and Shipment

Environment

The instrument should be stored in a clean, dry environment. The following limitations apply to both storage and shipment:

- Temperature -40 to +75°C
- Relative humidity <95%
- Altitude < 7,600 metres (25 000 ft)

Original Packaging

Containers and materials identical to those used in factory packaging are available through Agilent Technologies' offices. If the instrument is being returned to Agilent Technologies for servicing, attach a tag indicating the type of service required, return address, model number, and serial number. Also, mark the container FRAGILE

to assure careful handling. In any correspondence, refer to the instrument by model number and serial number.

Interconnections

Refer to the power meter operating and service manual for interconnecting instructions.

Operation Environment

The operating environment for the Power Sensor should be as follows:

Temperature	0 to +55°C
Relative humidity	<95%
Altitude	< 4,572 metres (15 000 ft)

Operating Precautions

Before the Power Sensor is connected, the following precautions must be observed.

Warning

BEFORE CONNECTING THE POWER SENSOR TO ANOTHER INSTRUMENT, ensure that the instrument and power meter are connected to the protective (earth) ground.

Caution

Exceeding the following energy and power levels may result in damage to the power meter system.

Maximum Average Power	300 mW
Maximum Peak Power	15W (10W 8483A Only)
Maximum Energy Per Pulse	30W · μ s

Do not apply torque to the Power Sensor's body while connecting or disconnecting the Type N RF connector.

Note

When using the Power Sensor with the 435 series Power Meter make sure the correct scale is mounted on the Power Meter RANGE switch. Refer to Section II of the Agilent Technologies 435 series Power Meter Operating and Service Manual.

Operating Procedures

Instructions for use of the Power Sensor are provided in the power meter manual. During operation, the precautions described under "Operating Precautions" must be observed.

SWR (Reflection Coefficient) Performance Test

The maximum SWR and reflection coefficient for each Power Sensor are listed in table 4. For making these measurements, use equipment which has measurement uncertainties not exceeding those shown in the table.

Table 4. SWR and Reflection Coefficient

Frequency	System SWR Uncertainty	Actual Measurement	Maximum SWR (Reflection Coefficient)
8481A			
10 to 30 MHz	±0.030	_____	< 1.40 (0.166)
30 to 50 MHz	±0.020	_____	< 1.18 (0.083)
50 MHz to 2 GHz	±0.020	_____	< 1.10 (0.048)
2 to 12.4 GHz	±0.020	_____	< 1.18 (0.083)
12.4 to 18 GHz	±0.025	_____	< 1.28 (0.123)
8482A			
100 kHz to 300 kHz	±0.08	_____	< 1.60 (0.231)
300 kHz to 1 MHz	±0.04	_____	< 1.20 (0.091)
1 MHz to 2 GHz	±0.02	_____	< 1.10 (0.048)
2 to 4.2 GHz	±0.02	_____	< 1.30 (0.130)
8483A			
100 kHz to 600 kHz	±0.08	_____	< 1.80 (0.286)
600 kHz to 2 GHz	±0.02	_____	< 1.18 (0.083)

FET Balance Adjustment

The FET balance adjustment should be performed if the wires connecting J1 to the A2 printed circuit have been moved. If you have replaced A2 or moved the wires during troubleshooting you will need to perform this adjustment. You do not need to perform a FET balance adjustment after an A1 bulkhead assembly replacement if the wires between J1 and A2 have not been disturbed.

Warning

The following procedure exposes high voltage areas within the power meter. Use extreme care while working around these areas or personal injury could occur.

Equipment

- Oscilloscope 54200A
- Power Meter 435B
- Multimeter 3478A

The sampling gate balance is affected by the relative positions of the wires in the Power Sensor, which connect to pins G and H of

connector J1. One wire is black and white; and the other is brown and white. Moving the black and white wire will adjust the switching transient amplitude (spike). Moving the brown and white will change the offset. Once positioned, care must be used not to displace these wires. To correctly position these wires, after replacement of the printed circuit board or if the wires have been moved so as to affect the sampling gate balance, perform the following procedure:

1. Set the multimeter controls as follows:

FUNCTION	dc Voltage
RANGE	20 mV, full scale

2. Set oscilloscope controls as follows:

SENSITIVITY	0.2 V/DIV
SWEEP	1 ms/DIV
TRIGGER	INT
DISPLAY	A

3. Set the Power Meter CAL FACTOR to 100%. Set the Power Meter RANGE to 1 mW (0 dBm).
4. Open the Power Sensor (see “Disassembly Procedure”, steps 1 through 3). Zero and calibrate the Power Meter. Leave the opened Power Sensor connected to the Power Meter POWER REF output. Heat can affect the adjustments so handle the sensor as little as possible.
5. Turn OFF the POWER REF switch on the rear panel of the Power Meter.
6. Remove the 435B bottom panel. This will expose the circuit side of the A5 printed circuit board. On A5 you will see a long double row of soldered terminals numbered 1 to 44.

Note

Opening the 435B meter may void the current calibration and/or warranty.

7. Connect a probe from pin 40 (the number “902” is printed on the board next to pin 40) to the multimeter input.
8. Lay the 435B on its left side and remove the right panel. This will expose the A4 assembly.
9. Connect a 1:1 probe from TP4 to channel A on the oscilloscope.
10. **Offset.** Read the multimeter and adjust the position of the brown and white wire until the reading is between -3.0 mV and $+2.0$ mV. *Helpful hint:* the relative position of the brown and white wire to C4 will adjust the offset.
11. **Switching transients.** Read the oscilloscope and adjust the position of the black and white wire until the switching transients are less than 0.8V peak to peak. *Helpful hint:* the relative position of the black and white wire to the collector of Q1 will adjust the switching transients.

You will find that positioning the wire for switching transients affects the offset. Go back and forth between the two wires, positioning and repositioning, until both adjustments are within specifications.

Replaceable Parts

Table 5 is a list of replaceable parts. Figure 2 illustrates the major parts. To order a part listed in the “Replaceable Parts” table, quote the part number with Check Digit (CD), indicate the quantity required, and address the order to the nearest Agilent Technologies office.

Note

Within the USA, it is better to order directly from the Agilent Technologies Parts Center. Ask your nearest Agilent Technologies office for additional information. Also, your nearest Agilent Technologies office can supply toll free telephone numbers for ordering parts and supplies.

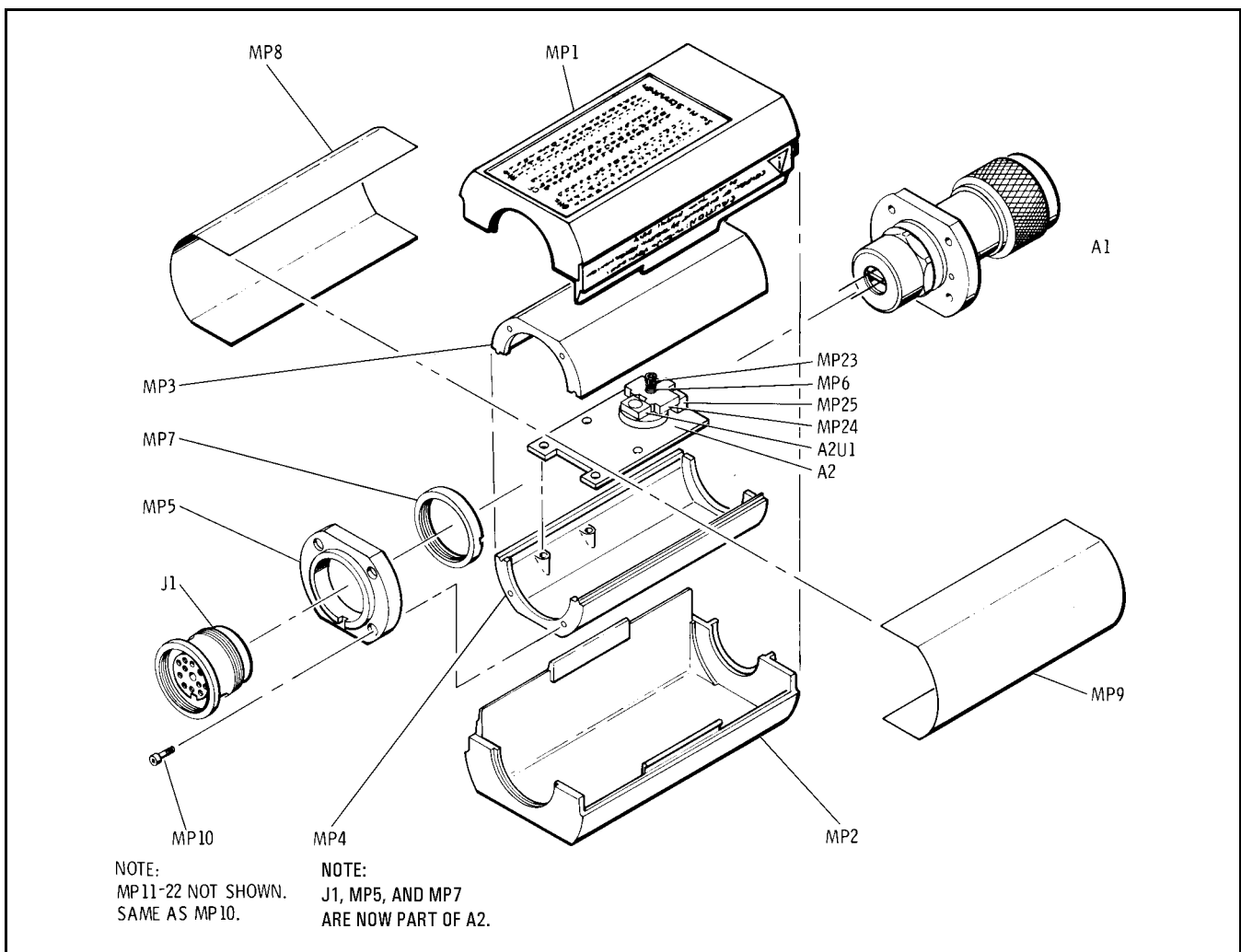

Figure 2. Illustrated Parts Breakdown

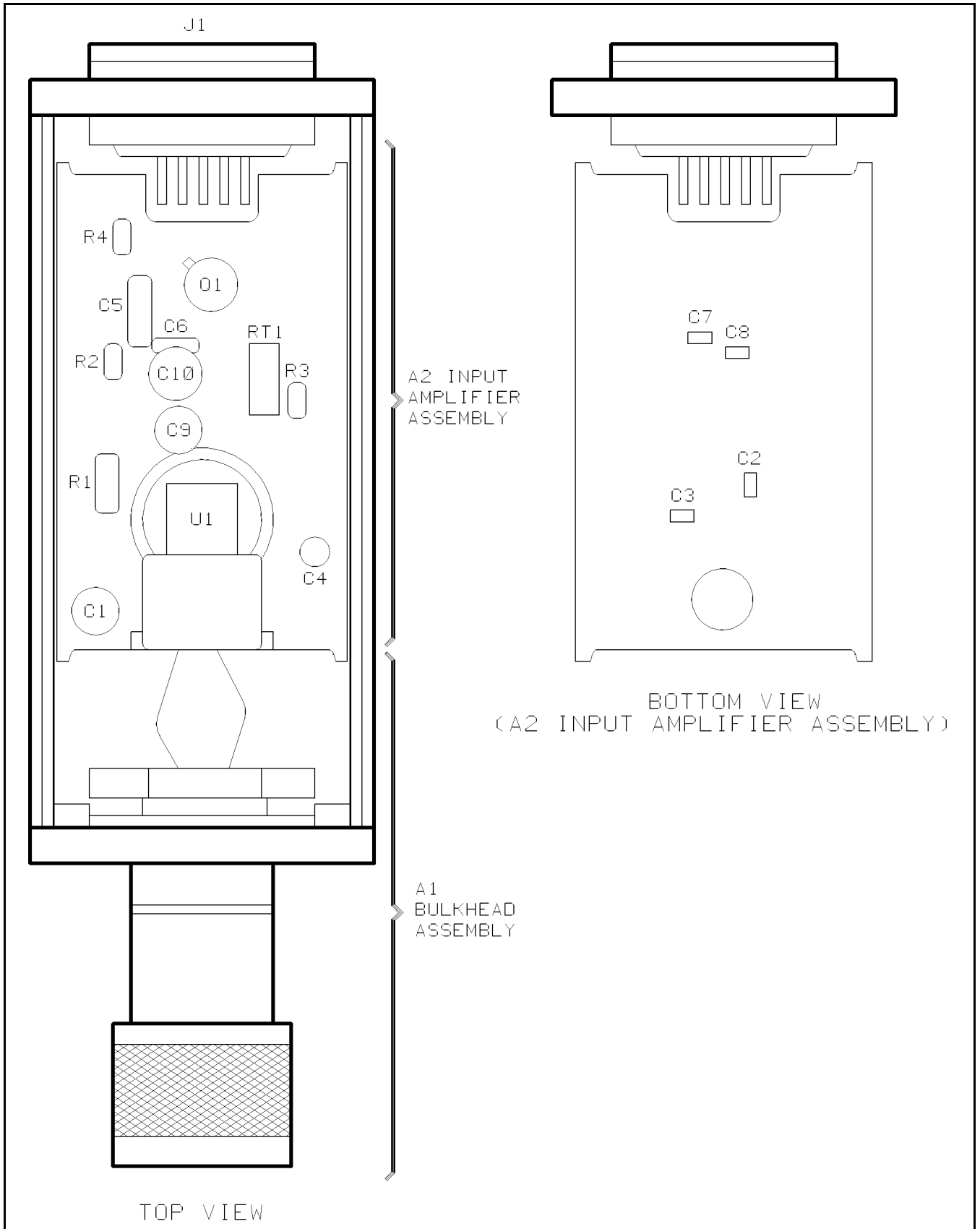

Figure 3. Component and Assembly Locations

Table 5. Replacement Parts

Reference Designation	Part Number	CD	Qty	Description	Mfr Code	Manufacturer Part Number
A1	08481-60004	3	1	BULKHEAD, TYPE N (FOR 8481A ONLY)	28480	08481-60004
A1	08481-60005	4	1	BULKHEAD, APC-7 (FOR 8481A OPT 001 ONLY)	28480	08481-60005
A1	08482-60003	3	1	BULKHEAD, TYPE N (FOR 8482A ONLY)	28480	08482-60003
A1	08483-60003	4	1	BULKHEAD, TYPE N (FOR 8483A ONLY)	28480	08483-60003
A1MP1	1250-0918	0	1	NUT-CONN RF		
A1MP1	1250-1466	6	1	7MM RF CONNECTION ASSY (OPT 001 ONLY)		
A1MP2	1250-0016	0	1	RING, RF CONN		
A1MP3	1250-0916	9	1	BODY, RF CONN		
A1MP4	1250-0917	0	1	CONNECTOR, RF CONTACT		
A1MP4	1250-0816	8	1	7MM CONTACT (OPT 001 ONLY)		
A1MP5	1460-0977	7	1	SPRING, COMPR		
A1MP6	5020-3296	1	1	CENTER CONDUCTOR		
A1MP7	5020-3297	2	1	SLIDING CONTACT		
A1MP8	5040-0306	0	1	INSULATOR		
A1MP9	0470-0013	2	1	SEALANT-THD RED		
A1MP10	08481-20015	2	1	BULKHEAD		
A1MP11	08481-20016	3	1	CAP NUT		
A1MP12	08481-40006	3	1	POLYIRON SLUG (8481A ONLY)		
A1MP13	08481-60009	8	1	CARTRIDGE ASSY (8481A ONLY)		
A1MP13	08481-69009	6	1	RESTORED CARTRIDGE ASSY (8481A ONLY)		
A1MP13	08482-60004	4	1	CARTRIDGE ASSY (8482A ONLY)		
A1MP13	08483-60006	7	1	CARTRIDGE ASSY (8483A ONLY)		
A1MP14	2190-0831	0	1	.010 WASHER-FLAT		
A2	5061-0982	8	1	BD AY PWR SENSOR (8481A, 8482A, 8483A)	28480	
A2C1	0180-2515	8	1	CAP-FXD 47uF 6 V TA	28480	0180-2515
A2C2	0160-5947	2	4	CAP-FXD 1000pF		
A2C3	0160-5947	2	1	CAP-FXD 1000pF	95275	VJ0805Y102MF
A2C4	0180-0594	9	1	CAP-FXD 3.3uF 15 V TA		202L1602-335-M4
A2C5	0160-3094	8	1	CAP-FXD 0.1uF 100 V	04222	SR301C104KAAH
A2C6	0160-3879	7	1	CAP-FXD 0.01uF 100 V	04222	SR201C103MAAH
A2C7	0160-5947	2	1	CAP-FXD 1000pF	95275	VJ0805Y102MF
A2C8	0160-5947	2	4	CAP-FXD 1000pF		
A2C9	0180-2515	8	1	CAP-FXD 47uF 6 V TA		202L6301-476-M7-552
A2C10	0180-2545	4	1	CAP-FXD 100uF 4 V TA		202L6301-107-M6-552
A2MP1	08481-20008	3	1	END BELL	28480	08481-20008
A2MP2	1251-3363	8	1	NUT-AUDIO CONN	28480	1251-3363

Table 5. Replacement Parts (continued)

Reference Designation	Part Number	CD	Qty	Description	Mfr Code	Manufacturer Part Number
A2Q1	1854-1179	0	1	X-N MP5A18 TO-92	04713	
A2R1	0698-3260	9	1	RESISTOR 464K +.1% .125W TF TC=0+-100	28480	0698-3260
A2U1	1813-0060	8	1	IC MISC TO-8 PKG MISCELLANEOUS PARTS	28480	1813-0060
A2MP5	0590-1040	1	1	NUT-PRESS IN	28480	0590-1040
A2MP6	5040-6938	6	1	SPACER	28480	5040-6938
A2J1	08481-60024	7	1	CONNECTOR ASSEMBLY, 12-PIN	28480	08481-60024
CHASSIS PARTS						
MP1	5040-6998	9	2	SHELL, PLASTIC	28480	5040-6998
MP2	5040-6998	9		SHELL, PLASTIC	28480	5040-6998
MP3	08481-20011	8	2	CHASSIS	28480	08481-20011
MP4	08481-20011	8		CHASSIS	28480	08481-20011
MP6	1460-1978	0	1	SPRING-CPRSN .088-IN-OD .188-IN-OA-KG	28480	1460-1978
MP8	08481-00002	5	2	SHIELD	28480	08481-00002
MP9	08481-00002	5		SHIELD	28480	08481-00002
MP10	0515-0879	1	9	SCREW-SMM 1.6 5 SHHX	28480	0515-0879
MP11	0515-0879	1		SCREW-SMM 1.6 5 SHHX	28480	0515-0879
MP12	0515-0879	1		SCREW-SMM 1.6 5 SHHX	28480	0515-0879
MP13	0515-0879	1		SCREW-SMM 1.6 5 SHHX	28480	0515-0879
MP14	0515-0879	1		SCREW-SMM 1.6 5 SHHX	28480	0515-0879
MP15	0515-0879	1		SCREW-SMM 1.6 5 SHHX	28480	0515-0879
MP16	0515-0879	1		SCREW-SMM 1.6 5 SHHX	28480	0515-0879
MP17	0515-0879	1		SCREW-SMM 1.6 5 SHHX	28480	0515-0879
MP18	0515-0879	1		SCREW-SMM 1.6 5 SHHX	28480	0515-0879
MP19	0515-0879	8	4	SCREW-SMM 1.6 5 SHHX	00000	0515-0879
MP20	0515-0879	8		SCREW-SMM 1.6 5 SHHX (USED TO MOUNT THE PRINTED CIRCUIT BOARD)	00000	0515-0879
MP21	0515-0879	8		SCREW-SMM 1.6 5 SHHX (USED TO MOUNT THE PRINTED CIRCUIT BOARD)	00000	0515-0879
MP22	0515-0879	8		SCREW-SMM 1.6 5 SHHX (USED TO MOUNT THE PRINTED CIRCUIT BOARD)	00000	0515-0879
MP23	3030-0436	4	1	SCREW-SKT HD CAP 0-80 .5-IN-LG SST-300	00000	ORDER BY DESCRIPTION
MP24	5040-6939	7	1	CLAMP	28480	5040-6939
MP25	5040-6940	0	1	BLOCK	28480	5040-6940
MP26	1250-0597	2	1	ADAPTER COAX STR M-N F-N		
MP27	08481-80002	3	1	8481A ID LABEL	28480	08481-80002
MP28	08482-80002	4	1	8482A ID LABEL	28480	08482-80002

Table 5. Replacement Parts (continued)

Reference Designation	Part Number	CD	Qty	Description	Mfr Code	Manufacturer Part Number
MP29	08483-80001	6	1	8483A ID LABEL	28480	08483-80001
MP30 ¹	08481-80115	7	1	CAL LABEL (BLANK) - ZEBRA	28480	
MP32	08486-80005	1	1	INFO LABEL (SIDE)	26480	08486-80005
MP33	7121-2422	7	1	LABEL - CAUTION	26480	7121-2422

1 For MP30, the zebra blank label is to be used with Zebra brand printers. No mylar overlay is necessary. For generating labels using an older track feed "impact" printer, please order 08486-80006 label blank and 08481-80005 mylar tape, to be installed as an overlay on top of the 08486-80006, after it is printed.

Table 6. Code List of Manufacturers

Mfr Code	Manufacturer Name	Address		Zip Code
00000	ANY SATISFACTORY SUPPLIER			
04213	CADDELL-BURNS MFG CO INC	MINEOLA	NY	11501
14140	EDISON ELEK DIV MCGRAW-EDISON	MANCHESTER	NH	03130
24546	CORNING GLASS WORKS BRADFORD)	BRADFORD	PA	16701
28480	AGILENT TECHNOLOGIES CORPORATE HQ	PALO ALTO	CA	94304
51959	VICLAN INC	SAN DIEGO	CA	92138

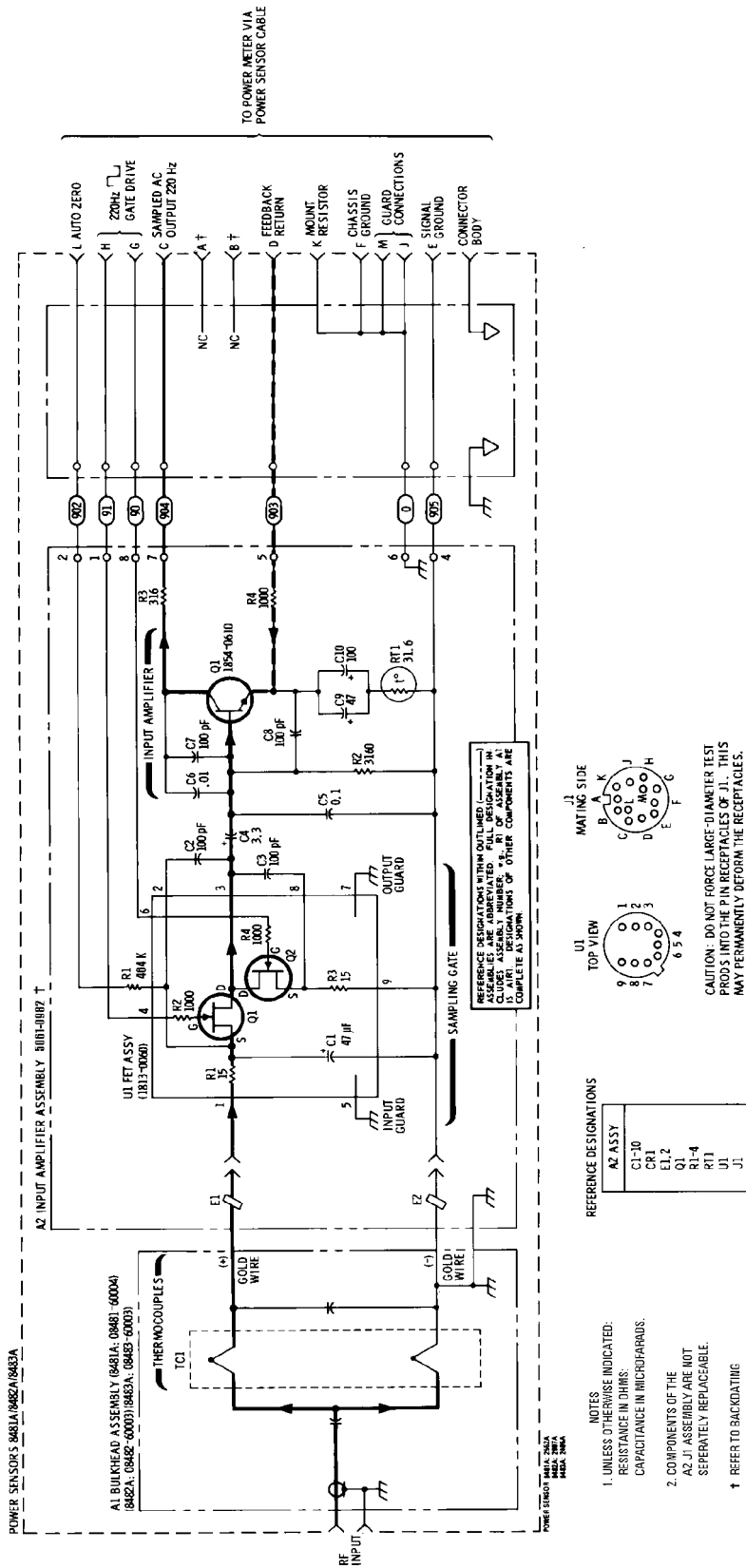

Figure 4. Schematic Diagram

Service

Service instructions consist of principles of operation, troubleshooting, and repairs. Test equipment which meets or exceeds the critical specifications in table 3 may be used in place of the recommended instruments for troubleshooting the Power Sensor.

Note

Check your warranty. Opening the Power Sensor will void warranty.

Principles of Operation

For the following discussion, refer to figure 4 Schematic Diagram and figure 5 Operational Amplifier. The operational amplifier is made up of the Power Sensor input amplifier, A2Q1, and the first amplifier stage in the power meter.

For additional information on thermocouple sensors, refer to Agilent Technologies Application Note 64-1C, "Fundamentals of RF and Microwave Power Measurements".

The A1 Bulkhead Assembly provides a 50 ohm load (8481A and 8482A) or a 75 ohm load (8483A) to the RF signal applied at the RF INPUT. The rf signal is coupled through a dc blocking capacitor and absorbed by the thermocouples which generate a dc voltage proportional to the rf input power. The dc voltage is routed from the thermocouples to the input amplifier on gold wires to reduce undesired thermocouple effects. The gold wires pass through ferrite beads A2E1 and A2E2 which are located in the black plastic block. (See figure 2.) The ferrite beads increase the self inductance of the gold wires causing this portion of the wires to provide the properties of an rf choke. The result is to minimize rf feedthrough to the A2 Input Amplifier Assembly.

The dc output from the bulkhead assembly is applied to the two field effect transistors (FETs) in A2U1. These transistors function as a sampling gate or chopper. The sampling rate is controlled by a 220 Hz square wave supplied by the power meter. The amplitude of the sampling gate output (at pin 3 of A2U1) is a 220 Hz square wave proportional to the power input. The sampled 220 Hz ac output is applied to the input amplifier A2Q1 which is the input stage for an operational amplifier (figure 5). The ac gain of the operational amplifier is approximately 700.

A dc feedback voltage from the power meter Auto Zero circuit is coupled to the input of FET A2U1Q1 to set the zero level. The voltage is developed across the voltage divider consisting of A2R1 and the series resistance of the thermocouple A1TC1.

When the Power Sensor is used with a Power Meter, the short to ground at J1-K (Mount Resistor) causes the power meter to automatically select the proper measurement range of -30 to $+20$ dBm. With the 435 series Power Meter this short serves no function.

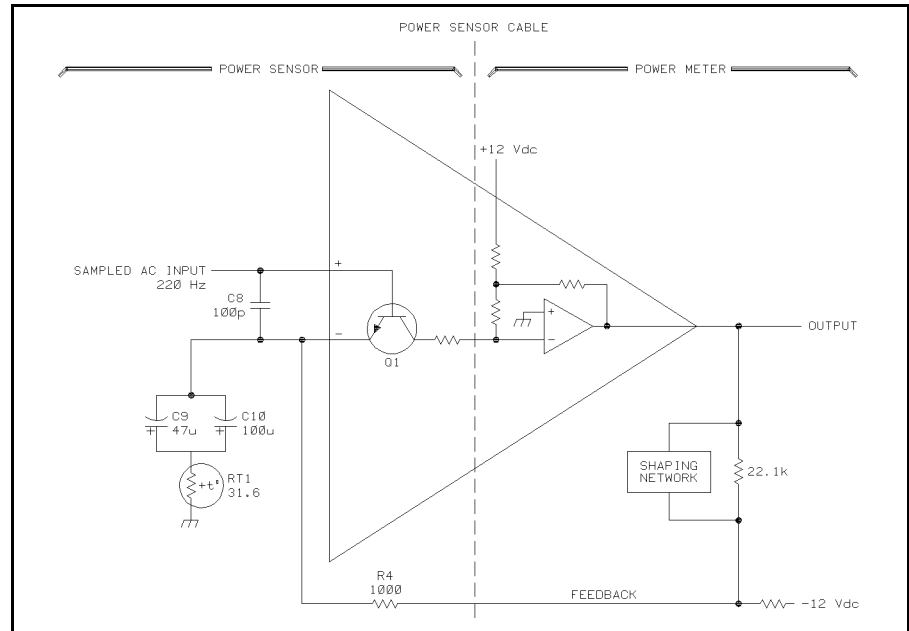

Figure 5. Operational Amplifier

Troubleshooting

The troubleshooting information is intended to first isolate the Power Sensor or power meter as the defective component. When the Power Sensor is isolated, troubleshooting information is intended to identify A1 Bulkhead Assembly or A2 Input Amplifier Assembly as the defective component.

Before you open the Power Sensor to continue with the troubleshooting procedures, try the substitution method of elimination. Use another power meter, known to be in good operating condition, with the suspected power sensor and cable. If the same problem occurs with the “known good” power meter, substitute a “known good” power sensor cable.

Troubleshooting should be performed with the Power Sensor opened, the printed circuit board exposed. See “Disassembly” close to the end of this manual.

When a failed assembly has been identified, go to “Repair” directly following “Troubleshooting”.

Caution

Excessive power will damage the thermocouples.

Power Meter

To ensure the power meter is providing the correct 220 Hz signal, check the following levels of the square wave with an oscilloscope.

- At the white-black wire: -0.05 ± 0.05 Vdc (top of square wave).
- At the white-brown wire: -9.0 Vdc (bottom of square wave).

If the levels are correct the Power Sensor is at fault. Continue troubleshooting A1 Bulkhead Assembly. If the levels are incorrect,

the power meter is at fault. Refer to the power meter service manual for troubleshooting information.

Power Sensor

The most common cause of Power Sensor failure is the application of power levels beyond the specified tolerance. The second most common cause of failure is applying torque to the body of the Power Sensor. Either of these common causes will damage the bulkhead cartridge unit (which holds the thermocouples). If this happens, the fault will cause a short or an open between the two gold wires.

Caution

Be extremely careful when measuring across the gold wires. They are delicate and can be damaged easily.

1. Disconnect all cables from the power sensor.
2. Remove the clamp holding the two gold wires.
3. Resistance measured between the two gold wires from the A1 Bulkhead Assembly should be 200 ± 10 ohms (8481A), 245 ± 12.5 ohms (8482A), or 375 ± 17.5 ohms (8483A). If you cannot obtain the proper resistance (failure is usually indicated by an open circuit) the A1 Bulkhead Assembly is defective. If the resistance is correct continue to “A2 Input Amplifier”.

A2 Input Amplifier Assembly

It is extremely rare for the A2 Assembly to fail. Eliminate the power meter, the bulkhead assembly and the connectors before suspecting the A2 Assembly.

In most cases, the operational amplifier (made up of A2Q1 and the first amplifier of the power meter, figure 5) is operating correctly if the dc voltage on the metal cover of A2Q1 (collector) is -70 ± 30 mV dc. Refer to the schematic to troubleshoot further.

Repair

Power Sensor repair consists of A1 Bulkhead replacement or repair and A2 Input Amplifier replacement.

Repair Strategy

Bulkhead. You can choose to either replace your A1 Bulkhead Assembly, or repair it yourself. We recommend replacing the A1 Bulkhead with a new or restored bulkhead over attempting to rebuild it. A restored Bulkhead is rebuilt and calibrated at the factory. It comes with a calibration report and new calibration sticker for your sensor.

If you decide to repair the bulkhead yourself, you should have an 11760S, 85127A E01 or equivalent automated power sensor calibration system and, when repairs are finished, the appropriate SWR test setup. (See table 4 for system specifications.)

Note

If you repair power sensors often and have the proper calibration systems, bulkhead repair can be more economical than replacement.

A2 Input Amplifier Assembly Printed Circuit. If the A2 Input Amplifier Assembly is at fault, replace it. Replacing the A2 Assembly is usually less costly than the time it takes to troubleshoot and replace faulty components. For those who wish to troubleshoot, use figure 4, “Power Sensor Schematic Diagram”.

Bulkhead Replacement

Read repair strategy, above. Bulkhead replacement differs from repair in that no special tools or skills are required other than those needed to do the FET balance adjustment.

Procedure

1. Order your new or restored A1 Bulkhead Assembly from table 5, “Replaceable Parts”.
2. Follow the disassembly and reassembly procedure for bulkhead removal and replacement located near the end of this manual.
3. Check the FET balance using the procedure that precedes the parts list. If you did not disturb the wires, it is likely that no adjustment will be necessary.
4. Place the new calibration sticker on the power sensor cover.

Bulkhead Repair

Read the repair strategy, above. Before beginning repair, inspect the center conductor and outer conductor with a magnifying glass. If you have any burrs or scratches visible on the connecting surfaces you should complete the entire procedure below or replace the bulkhead. If your connecting surfaces are acceptable, repair your bulkhead by replacing cartridge (A1MP16) starting with step 9. *Do not attempt repair without the following equipment.*

Equipment

Power Sensor Calibration System ..	11760S or 85127A E01
Type N Connector Gage	85054-60024 or equivalent
Precision 7mm Connector Gage (for Option 001)	1250-1875 or 85050-80012
SWR Test Set	See table 4 for specifications.

Rebuilding the Bulkhead.

1. Refer to the parts list and figures 6, 7, and 8. Order the internal type N bulkhead parts A1MP1 through A1MP12. (8482A and 8483A do not use A1MP12 polyiron slug. The precision 7mm connector A1MP1 comes assembled, so A1MP2 and MP3 are unnecessary.)

2. Set up the necessary equipment for your SWR test. See table 4 in this manual for system specifications.
3. Remove the bulkhead assembly from the Power Sensor. See the disassembly procedure near the end of this manual.
4. Using a 5/8 in (16mm) wrench remove the cap nut and disassemble the bulkhead. Save the cap nut A1MP11, and polyiron slug A1MP12. Discard the old parts.
5. Build the RF Connector Assembly A1MP1, MP2, and MP3. If you have an 8481A Option 001, ignore this step.
 - a. Slip the C-ring into the groove on the RF connector body (A1MP3).
 - b. Place the nut face down (knurled end up) on a flat surface.
 - c. While squeezing the C-ring with a long nose pliers, slide the connector body into the nut until the ring snaps into place.

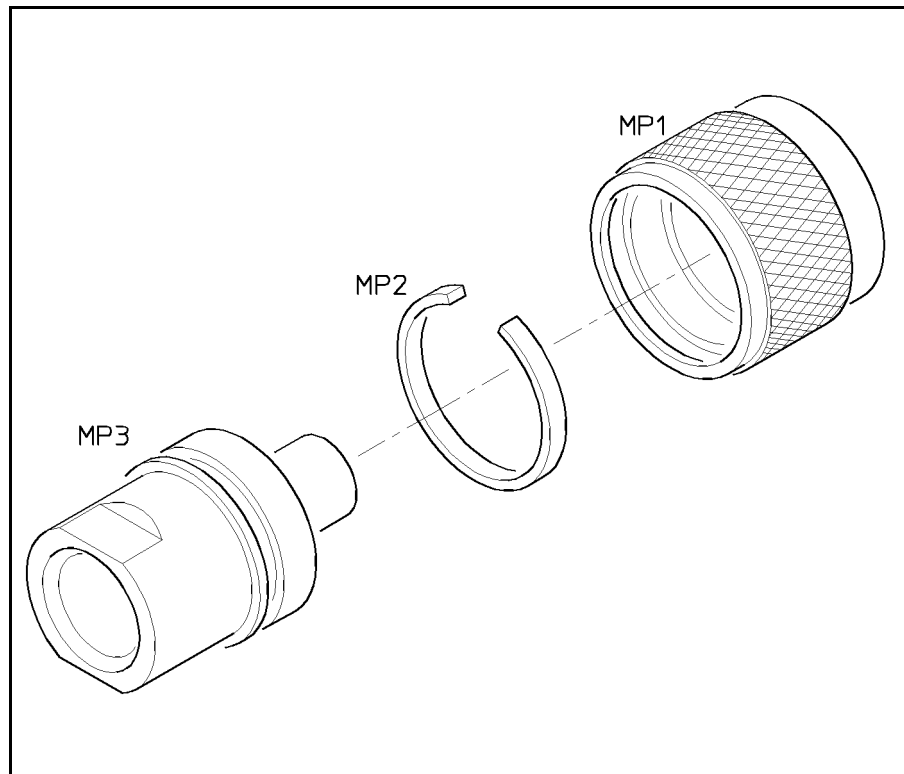

Figure 6. P/O A1 Bulkhead Assembly

6. Build the Center Pin Assembly A1MP4, 5, 6, 7, 8, and 9.
 - a. Insert the threaded end of center contact A1MP4, through the insulator A1MP8.
 - b. Place a very small amount (use the point of a wooden toothpick) of red anaerobic sealant A1MP9, on the threads of A1MP4. Be careful not to get any sealant near the insulator.

- c. Use your fingers to screw the center contact A1MP4 into the center conductor A1MP6 until tight. The round insulator should be squeezed tight enough so that it will not rotate. *Do not scratch or burr the two shafts.*
- d. Place the spring A1MP5 into A1MP6.
- e. Patiently place the sliding contact (snowflake) A1MP7 so that the snowflake fingers (without being damaged) surround the spring and press against the inner surface of center conductor A1MP6. The snowflake should spring back when pressed.

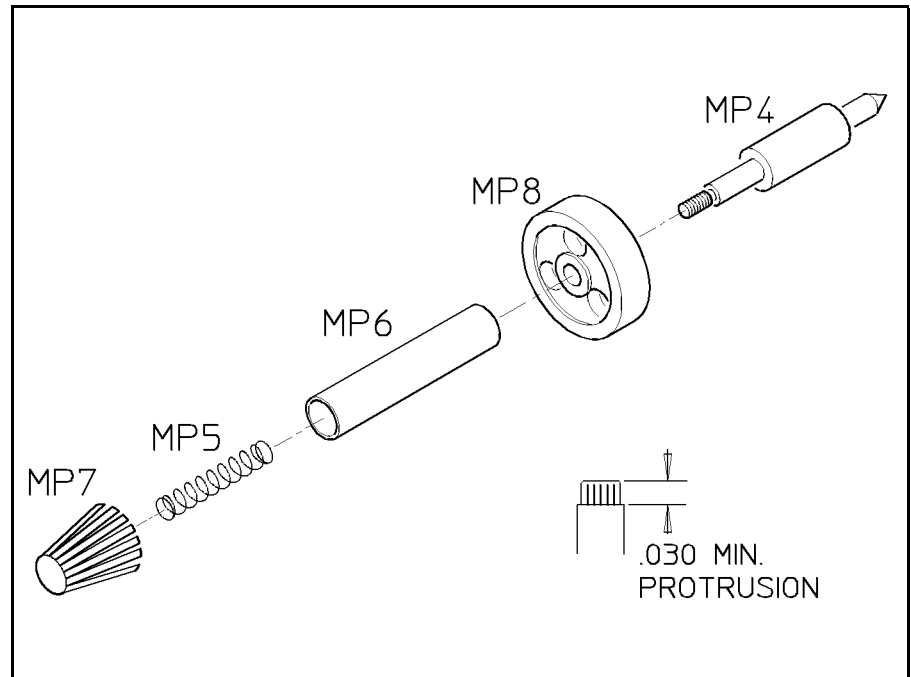

Figure 7. A1 Bulkhead Center Contact Assembly

7. Screw the bulkhead into the center pin assembly as shown in figure 8. Tighten in place to 50 ± 5 in-lbs (565 N·cm)
8. Use the appropriate gage to verify pin depth. When pin depth is correct go to next step, "Cartridge Replacement".

Cartridge Replacement. If you do not need to replace the inner and outer conductors of your bulkhead, start here. The procedure assumes the bulkhead assembly is removed from the Power Sensor.

9. Order one cartridge replacement A1MP13 from the replaceable parts list.
10. Place the bulkhead on its face, connector side down with the gold wires pointing up. Using a 5/8 in (16 mm) open end wrench, remove the cap nut A1MP11.
11. Turn the bulkhead assembly upside down and shake out the old parts. Watch where the polyiron slug A1MP12 rolls to and keep it for the new cartridge unit.

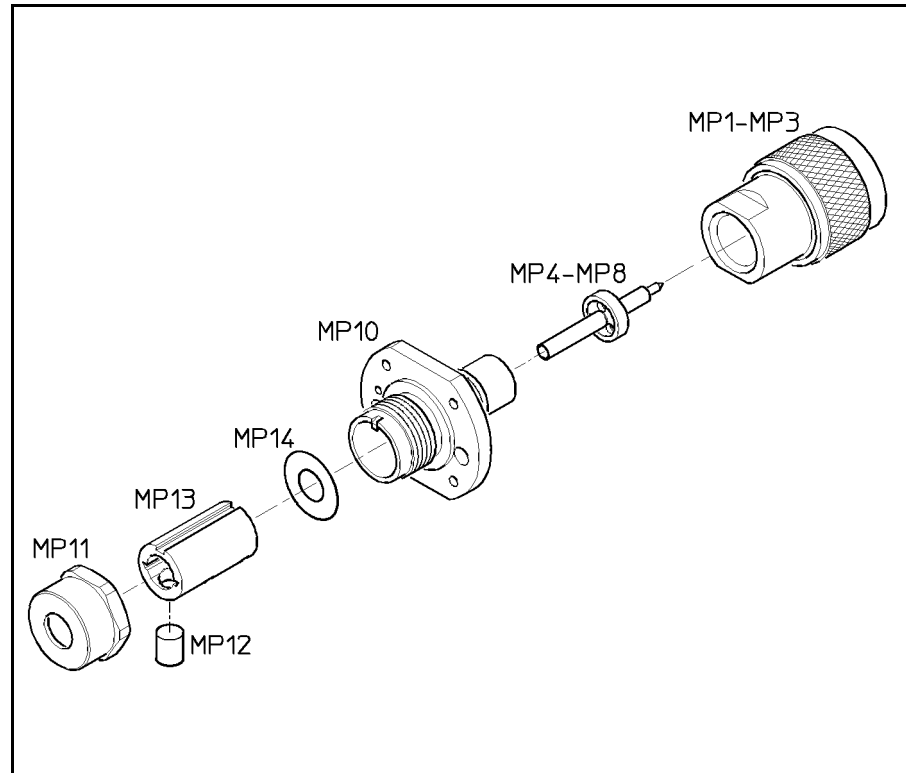

Figure 8. A1 Bulkhead Illustrated Parts Breakdown

Caution

The gold wires on the new cartridge unit are easily damaged and cannot be repaired.

12. Slip washer A1MP14 inside the bulkhead A1MP10 (for 8481A only). Now load in the new cartridge unit with the gold wires pointing out, holding the polyiron slug inside the unit until everything is in place.
13. Press the top of the bulkhead. A slight springlike action indicates the cartridge is properly seated. If the cartridge unit does not spring a little when pressed, carefully remove the cartridge unit (so you do not damage the gold wires) and use a thinner washer, A1MP15. If it still does not spring, you should rebuild the center conductor (step 6) with new parts.

Caution

Damage can occur to both the cartridge and center conductor if they are not properly mated. If no springlike action (or “give”) is present remove the cartridge assembly and rebuild the center conductor with new parts.

14. Tighten the cap nut to finger tight then torque the cap nut to to 35 ± 5 in-lbs (395 N·cm).
15. Reassemble the power sensor using the reassembly procedure at the end of this manual.

16. Test for SWR.
17. Check the FET balance using the procedure prior to Replaceable Parts. (If you were careful not to disturb the wires above the PC board (A2) this step may not be necessary.)
18. Calibrate the Sensor using your Automated Power Sensor Calibration System. Place the new sticker on the Power Sensor cover.

Connector Cleaning

Keeping in mind its flammable nature, a solution of pure isopropyl or ethyl alcohol can be used to clean connectors.

Caution

The RF connector bead deteriorates when contacted by any chlorinated or aromatic hydrocarbon such as acetone, trichlorethane, carbon tetrachloride, and benzene.

Do not attempt to clean connectors with anything metallic such as pins or paper clips.

Clean the connector face by first using a blast of compressed air. If the compressed air fails to remove contaminants use a cotton swab dipped in isopropyl or ethyl alcohol. If the swab is too big, use a round wooden toothpick wrapped in a lint free cloth dipped in isopropyl or ethyl alcohol.

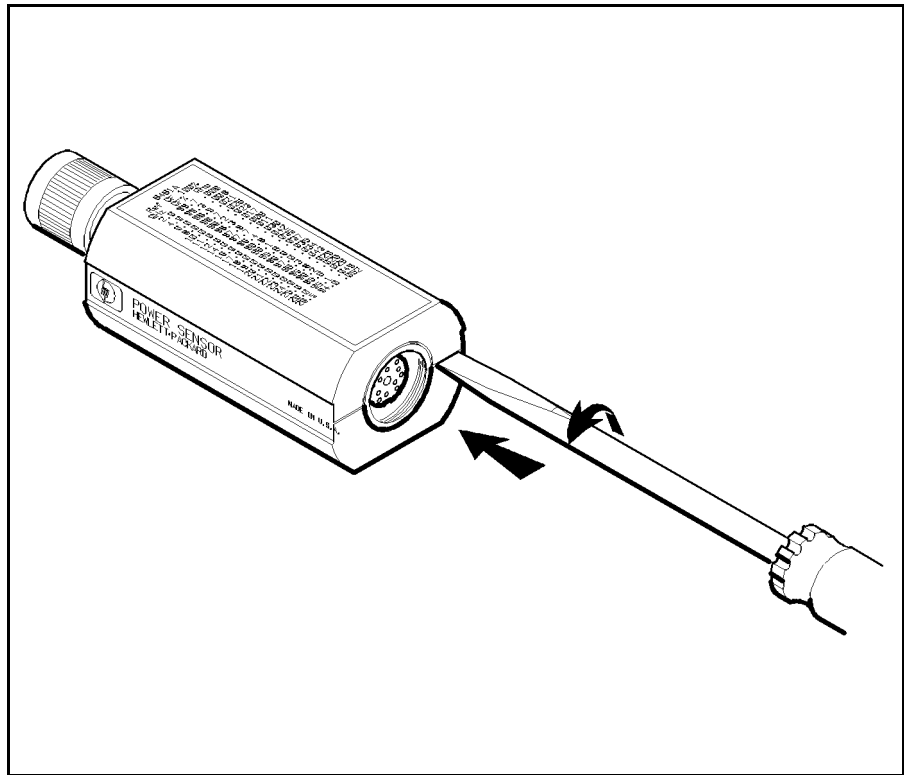

Figure 9. Removing the Power Sensor's Cover

Disassembly Procedure

Disassemble the Power Sensor by performing the following steps:

Caution

Disassembly must be performed in sequence described below, otherwise damage may be caused to the two gold wires between the bulkhead assembly and the input amplifier assembly. If these wires are damaged, the A1 Bulkhead Assembly must be repaired or returned to the factory for repair.

Note

Every Power Sensor has an individually prepared label on the housing. If more than one power sensor is disassembled at a time, be sure to mate the correct Power Sensor and housing when reassembling.

1. Insert the blade of a large screwdriver between the two-piece plastic shell at the rear of the Power Sensor. Gently pry the sections apart. (See figure 9.)
2. Proceed to the other side of the connector and again pry the cover sections apart. Remove the shells and magnetic shields.
3. Position the Power Sensor as shown in figure 8 (top). The small hole **5** should be on the left side of the RF input connector. Remove the allen cap screws **1**, **2**, **10**, and **13**. Loosen **11** and **12**. Remove the upper chassis from the Power Sensor.
4. Remove the spring clamp cap screw **7** to free the gold leads which come from the Bulkhead Assembly.
5. Remove cap screws **3**, **4**, and **5**.
6. Slide the Bulkhead Assembly straight out from the chassis.
7. Remove cap screws **8**, **9**, **11**, **12**, **14**, and **15**.
8. Lift the A2 Input Amplifier and J1 connector out of the chassis.

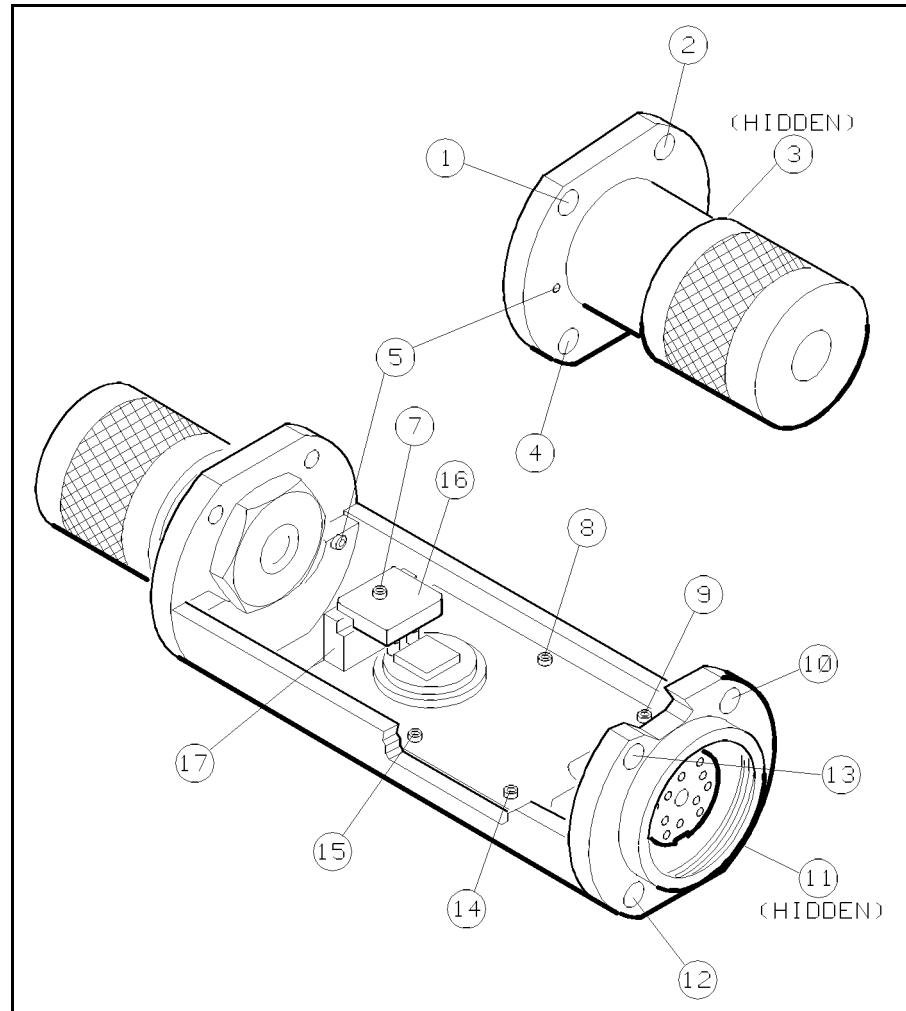

Figure 10. Power Sensor Hardware Locations

Reassembly Procedures

Caution

The gold wires connecting the A1 Bulkhead Assembly and the A2 Input Amplifier Assembly are extremely delicate and may be easily broken. Be careful when working around them.

1. Set the printed circuit board and connector into place as shown in figure 10, bottom view.
2. Insert cap screws **8**, **9**, **11**, **12**, **14**, and **15** but do not tighten.
3. Center the circuit board so there is equal air gap between each side and the chassis. Tighten **8**, **9**, **14**, and **15**.
4. With small hole **5** to the left, carefully insert the gold leads on A1 bulkhead assembly through the holes in the black plastic guide on A2 input amplifier.
5. Insert screw **3**, **4**, and **5**. Tighten only screw **5**.

6. Using tweezers, position the ends of the gold wires over the electrical pads.

Caution

DO NOT tighten clamp screw **6** excessively or the FET circuit may be broken.

7. Place and hold plastic clamp 16 over the gold wires. As you tighten the clamp screw, watch the compression spring. Tighten the clamp screw **7** only until the spring coils touch. Any further tightening could damage the FET circuit.
8. Place the upper chassis in position and insert cap screws **1**, **2**, **10**, and **13**.
9. Tighten **1**, **2**, **3**, and **4**.
10. Tighten **10**, **11**, **12**, and **13**.
11. Place the plastic shells, magnetic shields, and the chassis together as shown in figure 1. Snap the plastic shells together.

MANUAL CHANGES

This Appendix contains information for adapting this manual to instruments for which the content does not apply directly.

To adapt this manual to your instrument, refer to Table I-1 and make the changes listed opposite your instrument serial number.

Table I-1. Manual Changes by Serial Number

Agilent Instrument	Serial Prefix or Number	Make Manual Changes
8481A	1550A	I,H,F,D,B,A
	1926A	I,H,F,D,B
	2237A	I,H,F,D
	2349A	I,H,G,F
	2552A	I,H
	2702A	I
	8482A	1551A
1925A		I,H,G,D,B
2237A		I,H,G,D
2349A		I,H,G
2607A		I,H
2652A		I
8483A	1602A	I,H,G,E,D,C,B,A
	1925A	I,H,G,E,D,C,B
	2243A	I,H,G,E,D,C
	2329A	I,H,G,E,D
	2351A	I,H,G,E
	2405A	I,H,G,
	2623A	I,H
	2701A	I

CHANGE INSTRUCTIONS

CHANGE A Page 1-13, Table 5:
Change A2 part numbers as follows:

- 08481-60025 to 08481-60017
- 08482-60013 to 08482-60005
- 08483-60007 to 08483-60004

Change J1 to 1251-3228 CONNECTOR, 12 PIN FEMALE MULTICONTACT 90949 91T-3638.

Page 1-12, Figure 4:
Replace Figure 4 with Figure I-1.

CHANGE B Page 1-14, Table 5:
MP6. The part number for MP6 was originally 1460-1224, however, 1460-1978 is the recommended replacement.

Page 1-12, Figure 4:
Replace the area to the right of the A2 Input Amplifier Assembly with Figure I-1.

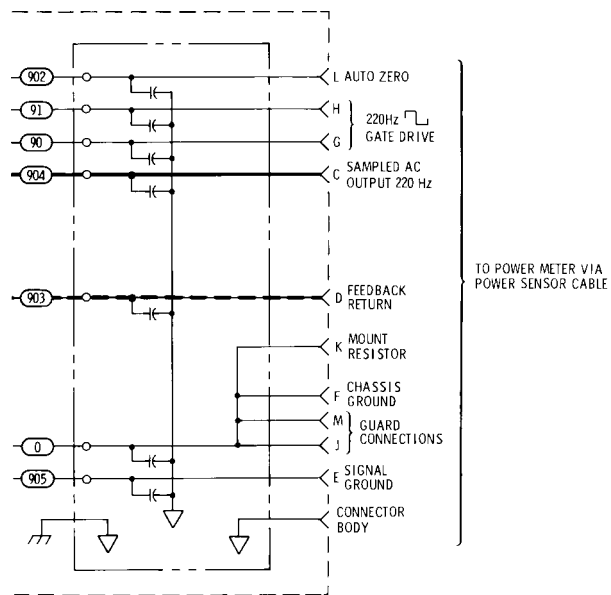

Figure I-1. J-1 Partial Schematic Diagram (P/O Change 2)

Page 1-14, Table 5:
MP 30. Change the part number and description of MP30 to: MP30 08483-00002 CD7 LABEL-CAL INSTRUCTIONS.

- CHANGE D** Page 1-12, Figure 4:
In the shaded area to the right of the schematic, connect pin A to the junction of pins F, M, and J.
- CHANGE E** Page 1-2:
Replace the sentence which reads:
“The REF CAL FACTOR, on the power sensor label, has been adjusted for the impedance mismatch.”
with:
“The CAL FACTOR at 50 MHz must be multiplied by 0.96 to determine the REF CAL FACTOR.”
- Page 1-14, Table 5:
MP10–MP18. The part number for MP10—MP18 was originally 3030-0422, however, 3030-0954 is the recommended replacement.
- Page 1-14, Table 5:
MP 30. Change the part number and description of MP30 to:
08483-00006 CD1 LABEL-CAL INSTRUCTIONS.
- CHANGE F** Page 1-14, Table 5:
MP27. Replace MP27 with the following:
7120-3118 CD0 LABEL, ID-LEFT (8481A ONLY)
- CHANGE G** Page 1-14 Table 5:
MP28. Replace MP28 with the following:
7120-4199 CD9 NAMEPLATE .315-IN-WD 2.745-IN-LG AL.
MP29. Replace MP29 with the following:
7120-4204 NAMEPLATE .315-IN-WD 2.745-IN-LG AL.
- CHANGE H** Page 1-11, Figure 3:
Replace figure 3, “Component and Assembly Locations”, with figure I-3.
- CHANGE I** Page 1, “Instruments Covered by Manual”:
This instrument has a two-part serial number. The first four digits and the letter comprise the serial number prefix. The last five digits form a sequential suffix which is unique to each instrument. The contents of this manual apply directly to instruments having the serial number prefix listed under “Serial Numbers” on the title page.

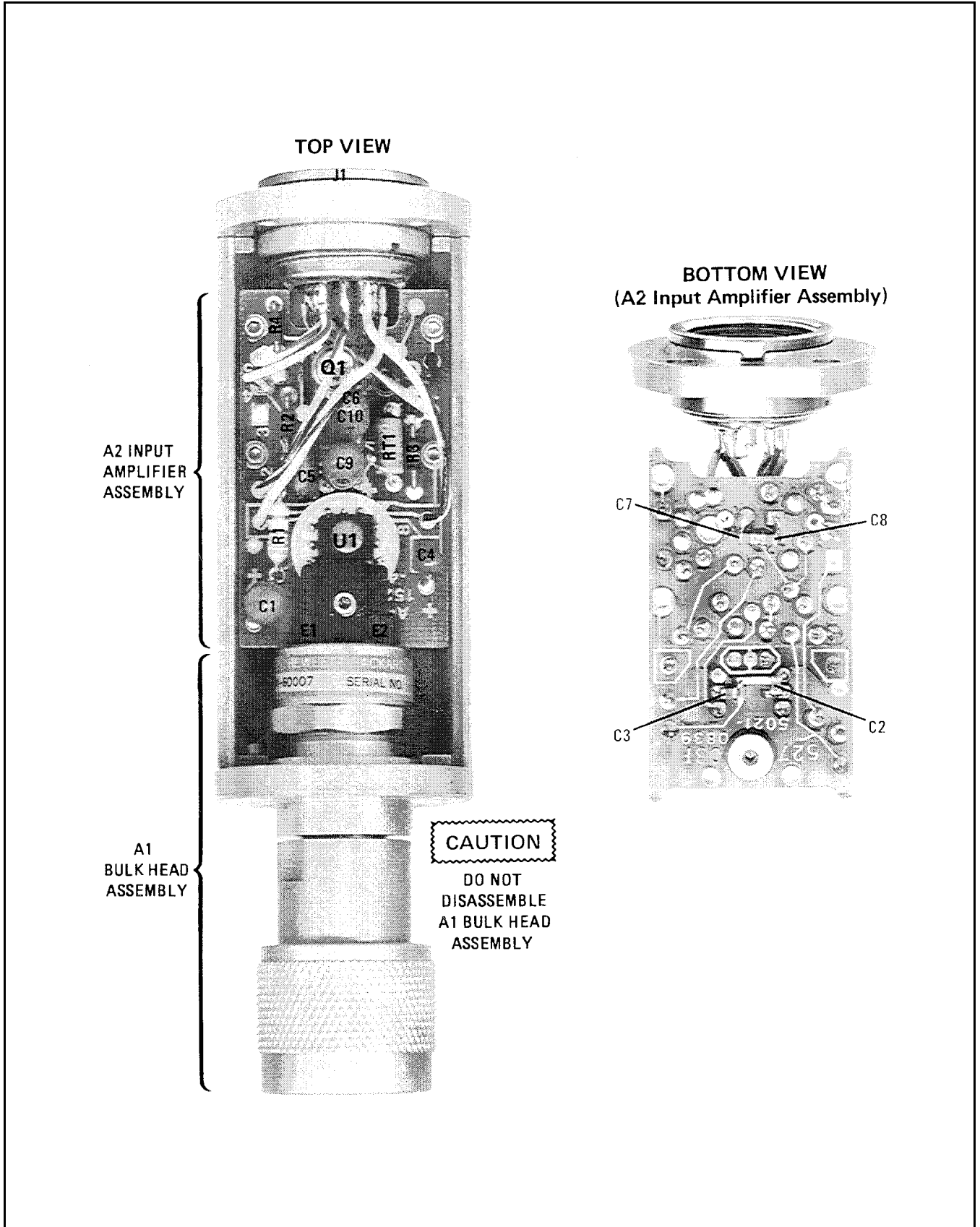

Figure I-3. Component and Assembly Locations

By internet, phone, or fax, get assistance with all your test & measurement needs.

Table A-1. Contacting Agilent

Online Assistance: www.agilent.com/find/assist

United States (tel) 1 800 452 4844	Japan (tel) (81) 426 56 7832 (fax) (81) 426 56 7840	New Zealand (tel) 0 800 738 378 (fax) 64 4 495 8950
Canada (tel) 1 877 894 4414 (fax) (905) 206 4120	Latin America (tel) (305) 269 7500 (fax) (305) 269 7599	Asia Pacific (tel) (852) 3197 7777 (fax) (852) 2506 9284
Europe (tel) (31 20) 547 2323 (fax) (31 20) 547 2390	Australia (tel) 1 800 629 485 (fax) (61 3) 9210 5947	