

Keysight M8195A Arbitrary Waveform Generator

User's Guide



NOTICE: This document contains references to Agilent Technologies. Agilent's former Test and Measurement business has become Keysight Technologies. For more information, go to www.keysight.com.



Notices

© Keysight Technologies, Inc. 2014

No part of this manual may be reproduced in any form or by any means (including electronic storage and retrieval or translation into a foreign language) without prior agreement and written consent from Keysight Technologies, Inc. as governed by United States and international copyright laws.

Manual Part Number

M8195-91020

Edition

Second edition, October 2014

Keysight Technologies,
Deutschland GmbH
Herrenberger Str. 130
71034 Böblingen, Germany

For Assistance and Support

<http://www.keysight.com/find/assist>

Limitation of Warranty

The foregoing warranty shall not apply to defects resulting from improper or inadequate maintenance by Buyer, Buyer-supplied software or interfacing, unauthorized modification or misuse, operation outside of the environmental specifications for the product, or improper site preparation or maintenance. No other warranty is expressed or implied. Keysight Technologies specifically disclaims the implied warranties of Merchantability and Fitness for a Particular Purpose.

ESD sensitive device

All front-panel connectors of the M8195A are sensitive to Electrostatic discharge (ESD). We recommend to operate the instrument in an electrostatic safe environment.

There is a risk of instrument malfunction when touching a connector.

Please follow this instruction:

Before touching the front-panel connectors, discharge yourself by touching the properly grounded mainframe.

Warranty

THE MATERIAL CONTAINED IN THIS DOCUMENT IS PROVIDED "AS IS," AND IS SUBJECT TO BEING CHANGED, WITHOUT NOTICE, IN FUTURE EDITIONS. FURTHER, TO THE MAXIMUM EXTENT PERMITTED BY APPLICABLE LAW, KEYSIGHT DISCLAIMS ALL WARRANTIES, EITHER EXPRESS OR IMPLIED, WITH REGARD TO THIS MANUAL AND ANY INFORMATION CONTAINED HEREIN, INCLUDING BUT NOT LIMITED TO THE IMPLIED WARRANTIES OF MERCHANTABILITY AND FITNESS FOR A PARTICULAR PURPOSE. KEYSIGHT SHALL NOT BE LIABLE FOR ERRORS OR FOR INCIDENTAL OR CONSEQUENTIAL DAMAGES IN CONNECTION WITH THE FURNISHING, USE, OR PERFORMANCE OF THIS DOCUMENT OR OF ANY INFORMATION CONTAINED HEREIN. SHOULD KEYSIGHT AND THE USER HAVE A SEPARATE WRITTEN AGREEMENT WITH WARRANTY TERMS COVERING THE MATERIAL IN THIS DOCUMENT THAT CONFLICT WITH THESE TERMS, THE WARRANTY TERMS IN THE SEPARATE AGREEMENT SHALL CONTROL.

Technology Licenses

The hardware and/or software described in this document are furnished under a license and may be used or copied only in accordance with the terms of such license.

Restricted Rights Legend

If software is for use in the performance of a U.S. Government prime contract or subcontract,

Software is delivered and licensed as "Commercial computer software" as defined in DFAR 252.227-7014 (June 1995), or as a "commercial item" as defined in FAR 2.101(a) or as "Restricted computer software" as defined in FAR 52.227-19 (June 1987) or any equivalent agency regulation or contract clause. Use, duplication or disclosure of Software is subject to Keysight Technologies' standard commercial license terms, and non-DOD Departments and Agencies of the U.S. Government will receive no greater than Restricted Rights as defined in FAR 52.227-19(c)(1-2) (June 1987). U.S. Government users will receive no greater than Limited Rights as defined in FAR 52.227-14 (June 1987) or DFAR 252.227-7015 (b)(2) (November 1995), as applicable in any technical data.

Safety Notices

CAUTION

A **CAUTION** notice denotes a hazard. It calls attention to an operating procedure, practice, or the like that, if not correctly performed or adhered to, could result in damage to the product or loss of important data. Do not proceed beyond a **CAUTION** notice until the indicated conditions are fully understood and met.

WARNING

A **WARNING** notice denotes a hazard. It calls attention to an operating procedure, practice, or the like that, if not correctly performed or adhered to, could result in personal injury or death. Do not proceed beyond a **WARNING** notice until the indicated conditions are fully understood and met.

Safety Summary

General Safety Precautions	<p>The following general safety precautions must be observed during all phases of operation of this instrument. Failure to comply with these precautions or with specific warnings elsewhere in this manual violates safety standards of design, manufacture, and intended use of the instrument. For safe operation the general safety precautions for the M9502A and M9505A AXIe chassis, must be followed. See: http://www.keysight.com/find/M9505A Keysight Technologies Inc. assumes no liability for the customer's failure to comply with these requirements. Before operation, review the instrument and manual for safety markings and instructions. You must follow these to ensure safe operation and to maintain the instrument in safe condition.</p>
Initial Inspection	<p>Inspect the shipping container for damage. If there is damage to the container or cushioning, keep them until you have checked the contents of the shipment for completeness and verified the instrument both mechanically and electrically. The Performance Tests give procedures for checking the operation of the instrument. If the contents are incomplete, mechanical damage or defect is apparent, or if an instrument does not pass the operator's checks, notify the nearest Keysight Technologies Sales/Service Office.</p> <p>WARNING To avoid hazardous electrical shock, do not perform electrical tests when there are signs of shipping damage to any portion of the outer enclosure (covers, panels, etc.).</p>
General	<p>This product is a Safety Class 3 instrument. The protective features of this product may be impaired if it is used in a manner not specified in the operation instructions.</p>
Environment Conditions	<p>This instrument is intended for indoor use in an installation category II, pollution degree 2 environment. It is designed to operate within a temperature range of 0 °C – 40 °C (32 °F – 105 °F) at a maximum relative humidity of 80% and at altitudes of up to 2000 meters.</p> <p>This module can be stored or shipped at temperatures between -40 °C and +70 °C. Protect the module from temperature extremes that may cause condensation within it.</p>
Before Applying Power	<p>Verify that all safety precautions are taken including those defined for the mainframe.</p>
Line Power Requirements	<p>The Keysight M8190A operates when installed in an Keysight AXIe mainframe.</p>
Do Not Operate in an Explosive Atmosphere	<p>Do not operate the instrument in the presence of flammable gases or fumes.</p>
Do Not Remove the Instrument Cover	<p>Operating personnel must not remove instrument covers. Component replacement and internal adjustments must be made only by qualified personnel. Instruments that appear damaged or defective should be made inoperative and secured against unintended operation until they can be repaired by qualified service personnel.</p>

Safety Symbols

Table 1 Safety Symbol







Symbol	Description
	Indicates warning or caution. If you see this symbol on a product, you must refer to the manuals for specific Warning or Caution information to avoid personal injury or damage to the product.
	C-Tick Conformity Mark of the Australian ACA for EMC compliance.
	CE Marking to state compliance within the European Community: This product is in conformity with the relevant European Directives.
	General Recycling Mark

Table 2 Compliance and Environmental Information

Symbol	Description
	This product complies with the WEEE Directive (2002/96/EC) marketing requirements. The affixed label indicates that you must not discard this electrical/electronic product in domestic household waste. Product category: With reference to the equipment types in the WEEE Directive Annexure I, this product is classed as a "Monitoring and Control instrumentation" product.
	Do not dispose in domestic household waste.
	To return unwanted products, contact your local Keysight office, or see www.keysight.com/environment/product/ for more information.

Contents

1	Introduction	
1.1	Document History	13
1.2	Options	14
1.3	The Front Panel of the M8195A Rev 001	16
2	M8195A User Interface	
2.1	Introduction	17
2.2	Launching the M8195A Soft Front Panel	18
2.3	M8195A User Interface Overview	20
2.3.1	Title Bar	20
2.3.2	Menu Bar	20
2.3.3	Status Bar	22
2.3.4	Clock/Output/Standard Waveform/ Multi-Tone Waveform/Complex Modulated Waveform/Import Waveform/Status/Control Tabs	22
2.3.5	Numeric Control Usage	22
2.4	Driver Call Log	24
2.5	Errors Window	25
2.6	Clock Tab	26
2.7	Output Tab	27
2.8	Standard Waveform Tab	29
2.9	Multi-Tone Waveform Tab	36
2.10	Complex Modulated Waveform Tab	41
2.11	Import Waveform Tab	50
2.12	Correction File Format	55
3	General Programming	
3.1	Introduction	57
3.2	IVI-COM Programming	58
3.3	SCPI Programming	59
3.3.1	AgM8195SFP.exe	60
3.4	Programming Recommendations	62
3.5	System Related Commands (SYSTEM Subsystem)	63
3.5.1	:SYSTEM:ERRor[:NEXT]?	63
3.5.2	:SYSTEM:HELP:HEADers?	63
3.5.3	:SYSTEM:LIcense:EXTended:LIST?	65
3.5.4	:SYSTEM:SET[?]	65
3.5.5	:SYSTEM:VERSion?	65
3.5.6	:SYSTEM:COMMunicate:*	66

3.6	Common Command List	69
3.6.1	*IDN?	69
3.6.2	*CLS	69
3.6.3	*ESE	69
3.6.4	ESR?	70
3.6.5	*OPC	70
3.6.6	*OPC?	70
3.6.7	*OPT?	70
3.6.8	*RST	70
3.6.9	*SRE[?]	71
3.6.10	*STB?	71
3.6.11	*TST?	71
3.6.12	*LRN?	71
3.6.13	*WAI?	71
3.7	Status Model	72
3.7.1	:STATus:PRESet	74
3.7.2	Status Byte Register	74
3.7.3	Questionable Data Register Command Subsystem	75
3.7.4	Operation Status Subsystem	77
3.7.5	Voltage Status Subsystem	79
3.7.6	Connection Status Subsystem	80
3.7.7	Run Status Subsystem	81
3.8	:ARM/TRIGger Subsystem	82
3.8.1	:ABORt[1 2 3 4]	82
3.8.2	:INITiate:IMMediate[1 2 3 4]	82
3.9	:INSTrument Subsystem	82
3.9.1	:INSTrument:SLOT[:NUMBer]?	82
3.9.2	:INSTrument:IDENtify [<seconds>]	83
3.9.3	:INSTrument:IDENtify:STOP	84
3.9.4	:INSTrument:DACMode[?] [DUALchannel FOURchannel]	84
3.10	:MMEMory Subsystem	84
3.10.1	:MMEMory:CATalog? [<directory_name>]	85
3.10.2	:MMEMory:CDIRectory [<directory_name>]	85
3.10.3	:MMEMory:COPY <string>,<string>[,<string>,<string>]	86
3.10.4	:MMEMory:DELeTe <file_name>[,<directory_name>]	87
3.10.5	:MMEMory:DATA <file_name>,<data>	87
3.10.6	:MMEMory:DATA? <file_name>	88
3.10.7	:MMEMory:MDIRectory <directory_name>	88
3.10.8	:MMEMory:MOVE <string>,<string>[,<string>,<string>]	88
3.10.9	:MMEMory:RDIRectory <directory_name>	90
3.10.10	:MMEMory:LOAD:CState <file_name>	90
3.10.11	:MMEMory:STORe:CState <file_name>	90
3.11	:OUTPut Subsystem	91
3.11.1	:OUTPut[1 2 3 4][:STATe][?] OFF ON 0 1	91
3.12	Sampling Frequency Commands	92

	3.12.1	[[:SOURce]:FREQuency:RASTer[?] <frequency> MINimum MAXimum	92
	3.13	:VOLTage Subsystem	93
	3.13.1	[[:SOURce]:VOLTage[1 2 3 4]::LEVel[:IMMediate]::AMPLitude][?] <level>	93
	3.13.2	[[:SOURce]:VOLTage[1 2 3 4]::LEVel[:IMMediate]::OFFSet[?] <level>	94
	3.13.3	[[:SOURce]:VOLTage[1 2 3 4]::LEVel[:IMMediate]::HIGH[?] <level>	94
	3.13.4	[[:SOURce]:VOLTage[1 2 3 4]::LEVel[:IMMediate]::LOW[?] <level>	94
	3.14	Frequency and Phase Response Data Access	95
	3.14.1	[[:SOURce]: CHARacterist[1 2 3 4]::VALue]?	95
	3.15	:TRACe Subsystem	95
	3.15.1	Waveform Memory Capacity	96
	3.15.2	Waveform Length Granularity and Size	96
	3.15.3	Waveform Data Format	96
	3.15.4	Arbitrary Waveform Generation	97
	3.15.5	:TRAC[1 2 3 4]:DEF	98
	3.15.6	:TRAC[1 2 3 4]:DEF:NEW?	99
	3.15.7	:TRAC[1 2 3 4]:DEF:WONL	100
	3.15.8	:TRAC[1 2 3 4]:DEF:WONL:NEW?	101
	3.15.9	:TRAC[1 2 3 4]:DATA[?]	102
	3.15.10	:TRAC[1 2 3 4]:IMP	103
	3.15.11	:TRAC[1 2 3 4]:DEL	110
	3.15.12	:TRAC[1 2 3 4]:DEL:ALL	110
	3.15.13	:TRAC[1 2 3 4]:CAT?	110
	3.15.14	:TRAC[1 2 3 4]:FREE?	110
	3.15.15	:TRAC[1 2 3 4]:NAME[?]	111
	3.15.16	:TRAC[1 2 3 4]:COMM[?]	112
	3.16	:TEST Subsystem	113
	3.16.1	:TEST:PON?	113
	3.16.2	:TEST:TST?	113
4		Examples	
	4.1	Introduction	115
	4.2	Remote Programming Examples	115
	4.3	Example Files for Import	115
	4.4	Example Correction Files	115
	4.5	Example Custom Modulation Files	116
5		Appendix	
	5.1	Resampling Algorithms for Waveform Import	117
	5.1.1	Resampling Requirements	117
	5.1.2	Resampling Methodology	118

1 Introduction

1.1 [Document History](#) / 13

1.2 [Options](#) / 14

1.3 [The Front Panel of the M8195A Rev 001](#) / 16

Introduction

The Keysight M8195A is a 65 GSa/s Arbitrary Waveform Generator with highest bandwidth and channel density. It offers up to 16 GSa waveform memory. The M8195A is ideally suited to address following key applications:

- Coherent optical – a single M8195A module can generate 2 independent I/Q baseband signals (dual polarization = 4 channels) at up to 32 Gbaud and beyond.
- Multi-level / Multi-channel digital signals – generate NRZ, PAM4, PAM8, DMT, etc. signals at up to 32 Gbaud. Embed/De-embed channels, add Jitter, ISI, noise and other distortions.
- Physics, chemistry, and electronics research – generate any mathematically defined arbitrary waveforms, ultra-short yet precise pulses and extremely wideband chirps.

Wideband RF/ μ W – generate extremely wideband RF signals with an instantaneous bandwidth of DC to 20 GHz for aerospace/defense/communication applications.

- Features and Benefits** The M8195A is an arbitrary waveform generator with highest sample rate, bandwidth, and channel density:
- Sample rate up to 65 GSa/s (on each channel)
 - Analog bandwidth: 20 GHz
 - Vertical resolution: 8 bits
 - 1, 2, or 4 differential channels per 1-slot high AXIe module (number of channels is software upgradable)
 - Built-in frequency and phase response calibration
 - Amplitude up to 1 Vpp (single ended) (2 Vpp (differential))
 - $V_{T_{\text{Rise}},20\% \dots 80\%} T_{\text{Fall},20\% \dots 80\%}$: 18 ps (typ.)
 - Ultra low intrinsic Random Jitter $RJ_{\text{rms}} < 200$ fs
 - Form factor: 1-slot AXIe module controlled via external PC or embedded AXIe system controller M9536A

- Supporting Operating System** The Keysight M8195A supports the following operating systems:
- Windows 8.1 (32 bit or 64 bit)
 - Windows 8 (32 bit or 64 bit)
 - Windows 7 (32 bit or 64 bit)

- Additional Documents** Additional documentation can be found at:
- <http://www.keysight.com/find/M9514A> for 13-slot chassis related documentation.
 - <http://www.keysight.com/find/M9505A> for 5-slot chassis related documentation.
 - <http://www.keysight.com/find/M9502A> for 2-slot chassis related documentation.
 - <http://www.keysight.com/find/M9045A> for PCIe laptop adapter card related documentation.
 - <http://www.keysight.com/find/M9047A> for PCIe desktop adapter card related documentation.
 - <http://www.keysight.com/find/M9536A> for embedded AXIe controller related documentation.
 - <http://www.keysight.com/find/M8195A> for AXIe based AWG module related documentation.

1.1 Document History

First Edition (September, 2014)	The first edition of the User's Guide describes the functionality of the M8195A Version 1.0 .
Second Edition (October, 2014)	The second edition of the User's Guide describes the functionality of the M8195A Version 1.1.

1.2 Options

For the M8195A Rev001, following product options are available.

Table 3: Options provided by M8195A

Product Number	Description	Comment
M8195A-R12	2 channel, 65 GSa/s AWG, 256 kSa per channel	Must order either -R12 or -R14
M8195A-R14	4 channel, 65 GSa/s AWG, 256 kSa per channel	Must order either -R12 or -R14
M8195A-U12	Upgrade from Rev 1 to Rev 2 for M8195A-R12	Hardware exchange
M8195A-U14	Upgrade from Rev 1 to Rev 2 for M8195A-R14	Hardware exchange

- Option -R12 or -R14** With this option the number of channels is selected. The M8195A is available as a two channel (-R12) or 4 channel (-R14) instrument. There is no upgrade possible from option -R12 to option -R14.
- Option -U12 or -U14** These options can be ordered to get an upgrade from M8195A Rev001 to the M8195A Rev 002. This upgrade is offered as a hardware exchange.

1.3 The Front Panel of the M8195A Rev 001

The Front Panel of the M8195A Rev 001 is shown in the figure below.



Figure 1: Front panel of M8195A

Outputs

The M8195A offers two or four differential analog outputs of the Digital to Analog Converters (DAC).

Note: The 2-channel version (-R12) and the 4-channel version (-R14) are both equipped with four differential outputs. The 2-channel version uses channel 1 and channel 4. Channels 2 and 3 are always disabled.

Note: The Data Outputs can be used differentially or single-ended. In case the output is used single-ended, the unused output must be terminated with 50 Ohm to GND to achieve optimum signal quality.

Status LED

Following LEDs are available at the front panel to indicate the status of the AWG module:

- The green '**Access**' LED:
 - It indicates that the controlling PC exchanges data with the AWG module.
- The red '**Fail**' LED has following functionality:
 - It is 'ON' for about 30 seconds after powering the AXIe chassis.
 - After about 30 seconds the LED is switched 'OFF'. If an external PC is used to control the AXIe chassis, this PC can be powered after this LED has switched OFF.
 - During normal operation of the module this LED is 'OFF'. In case of an error condition such as e.g. a self-test error, the LED is switch 'ON'.
- Four '**Channel**' LEDs:
 - It is 'OFF' when the channel is disabled and no overload condition at this channel has been detected.
 - It is 'GREEN' if the channel is enabled and no overload condition at this channel has been detected.
 - It is 'RED' if the internal protection circuit of that channel has detected an overload condition. Potential overload conditions are e.g. an external short to GND or 50 Ohm termination to a wrong externally applied termination voltage V_{Term} . In case an overload condition is detected, remove the overload condition of the test set-up and enable the channel.

2 M8195A User Interface

- 2.1 Introduction / 17
- 2.2 Launching the M8195A Soft Front Panel / 18
- 2.3 M8195A User Interface Overview / 20
- 2.4 Driver Call Log / 24
- 2.5 Errors Window / 25
- 2.6 Clock Tab / 26
- 2.7 Output Tab / 27
- 2.8 Standard Waveform Tab / 29
- 2.9 Multi-Tone Waveform Tab / 36
- 2.10 Complex Modulated Waveform Tab / 41
- 2.11 Import Waveform Tab / 50
- 2.12 Correction File Format / 55

2.1 Introduction

This chapter describes the M8195A Soft Front Panel.

2.2 Launching the M8195A Soft Front Panel

There are three ways to launch the M8195A Soft Front Panel:

1. Select **Start > All Programs > Keysight M8195 > Keysight M8195 Soft Front Panel** from the Start Menu.
2. From the Keysight Connection Expert select the discovered M8195 module, press the right mouse key to open the context menu and select “Send Commands To This Instrument”.
3. From the Keysight Connection Expert select the discovered M8195 module, select the “Installed Software” tab and press the “Start SFP” button.

The following screen will appear:

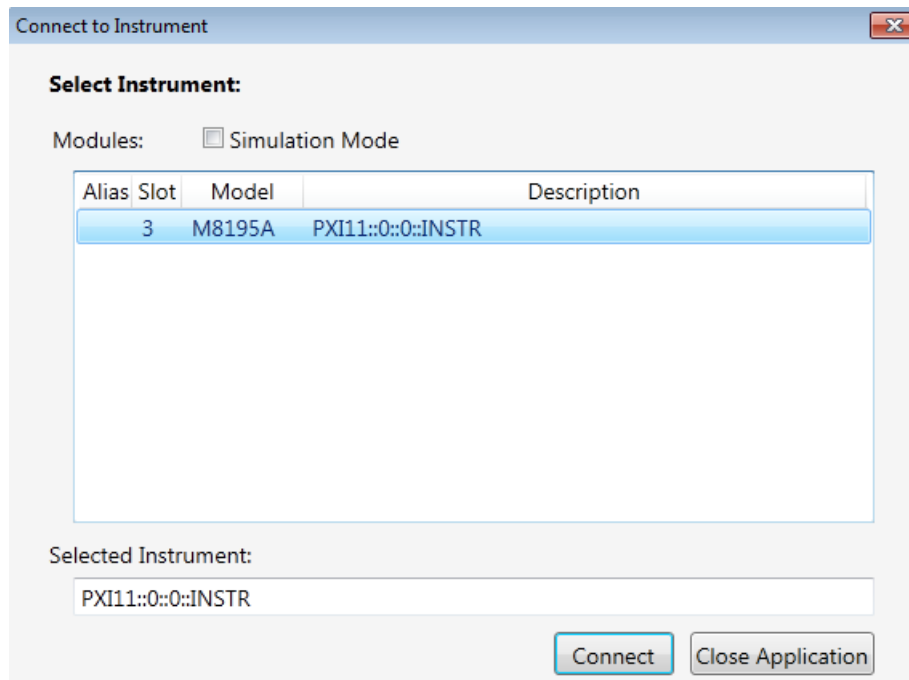

Figure 2: M8195A connected to PC

The instrument selection dialog shows the addresses of the discovered M8195A modules. Select a module from the list and press “Connect”.

If no M8195A module is connected to your PC, you can check “Simulation Mode” to simulate an M8195A module.

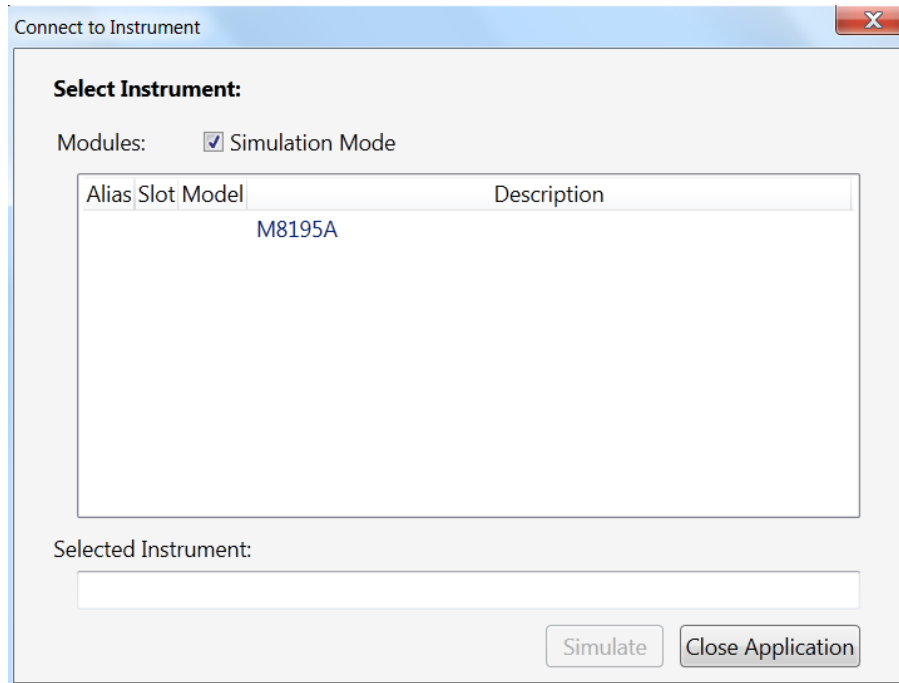

Figure 3: M8195A connected in simulation mode

2.3 M8195A User Interface Overview

The M8195A user interface includes the following GUI items:

- Title Bar
- Menu Bar
- Status Bar
- Tabs (Clock, Output, Standard Waveform, Multi-Tone Waveform, Complex Modulated Waveform, and Import Waveform)

The detailed information on these GUI items is described in the sections that follow.

2.3.1 Title Bar

The title bar contains the standard Microsoft Windows elements such as the window title and the icons for minimizing, maximizing, or closing the window.

2.3.2 Menu Bar

The menu bar consists of various pull down menus that provide access to the different functions and launch interactive GUI tools.

The menu bar includes the following pull down menu:

- File
- View
- Utilities
- Tools
- Help

Each menu and its options are described in the following sections.

2.3.2.1 File Menu

The File menu includes the following selections:

- File – Connect...
Opens the instrument selection dialog.
- File – Save Configuration As...
Saves configuration as a text file.
- File – Load Configuration...
Load the previously saved configuration file.
- File – Exit
Exits the user interface.

2.3.2.2 View Menu

The View menu includes the following selections:

- View – Refresh
Reads the instrument state and updates all fields.

2.3.2.3 Utilities Menu

The Utility menu includes the following selections:

- Utility – Reset
Resets the instrument, reads the state and updates all fields.
- Utility – Errors...
Opens the **Errors Window** to display the errors reported by the instrument.
- Utility – Self Test...
Opens a window to start the self-test and display the result after completion.

2.3.2.4 Tools Menu

The Tools menu includes the following selections:

- Tools – Monitor Driver Calls
Opens the **Driver Call Log** window.

2.3.2.5 Help Menu

The Help menu includes the following selections:

- Help – Online Support
Opens the instrument's product support web page.
- Help – About
Displays revision information for hardware, software and firmware. Displays the serial number of the connected module.

2.3.3 Status Bar

The Status Bar contains three fields from left to right:

- Connection state
 “Not Connected” – No instrument is connected.
 “Connected: <Instrument resource string>” – An instrument is connected. The resource string, for example PXI36::0:0::INSTR is displayed.
 “Simulation Mode” – No real instrument is connected. The user interface is in simulation mode.
 Click this field to open the Instrument Selection Dialog.
- Instrument status
 Displays the instrument status, for example “Reset complete” after issuing a reset command. In case of error it displays additional error information.
- Error status
 “Error” – The connected instrument reported an error.
 “No Error” – No errors occurred.
 Click this field to open the Report Error Window.

2.3.4 Clock/Output/Standard Waveform/ Multi-Tone Waveform/Complex Modulated Waveform/Import Waveform Tabs

These tabs are used to configure the most important parameters of the M8195A module. They are described in detail in the sections that follow.

2.3.5 Numeric Control Usage

The numeric control is used to adjust the value and units. Whenever you bring the mouse pointer over the numeric control, a tooltip appears which shows the possible values in that range.

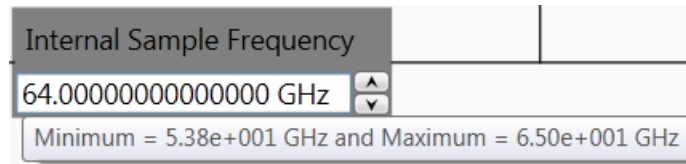

Figure 4: Tooltip showing possible values in the range

The numeric controls can be used in the following ways:

- Use the up/down arrows to change the value. The control automatically stops at the maximum/minimum allowed value.
- You can increase or decrease the value starting at a specific portion of the value. To do this, place the cursor to the right of the targeted digit and use the up/down arrows. This is especially useful when changing a signal characteristic that is immediately implemented, and observing the result in another instrument. For example, you can change the signal generator’s frequency by increments of 10 MHz and observe the measured result in a signal analyzer:

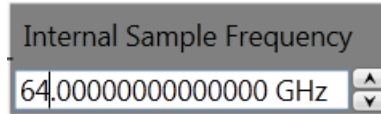

Figure 5: : Typing directly into the field

- Type directly into the field and press the Enter key. If you enter a value outside the allowed range, the control automatically limits the entered value to the maximum or minimum allowed value.
- When you type the value, you can type the first letter of the allowed unit of measure to set the units. For example, in the Frequency control you can use "H", "K", "M", or "G" to specify hertz, kilohertz, megahertz, or gigahertz, respectively. (The control is not case sensitive.)

The controls allow scientific notation if it is appropriate to the allowed range. Type the first decimal number, enter an "E", and omit any trailing zeroes. For example, in the Frequency control you can type 2.5e+9 and press Enter to set the frequency to 2.5 GHz. (The plus sign is automatically inserted if it is omitted.)

2.4 Driver Call Log

Use this window to inspect the sequence of IVI driver calls and SCPI commands used to configure the M8195A module.

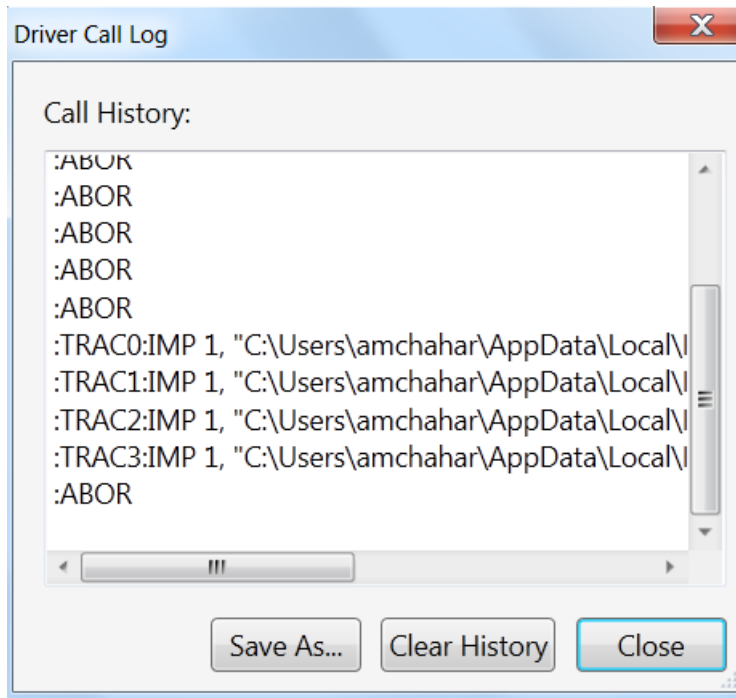

Figure 6: : Driver call log window

It has the following buttons:

- Save As...
Saves the Driver Call Log as a text file.
- Clear History
Clears the Driver Call Log.
- Close
Exits the window.

2.5 Errors Window

Use this window to read out and display the error queue of the M8195A module.

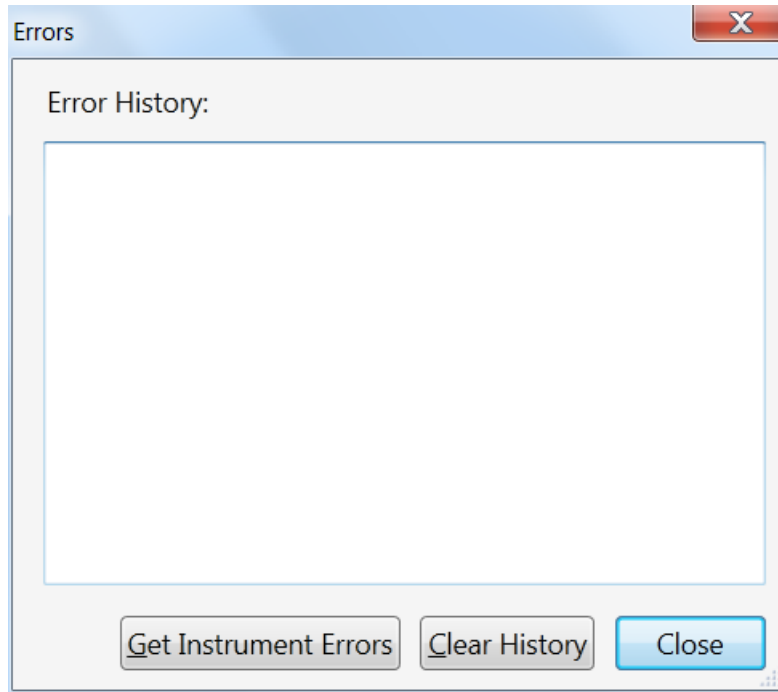

Figure 7: : Errors window

It has the following buttons:

- Get Instrument Errors
Queries the instruments error queue and displays the errors, if any.
- Clear History
Clears the error history.
- Close
Exits the window.

2.6 Clock Tab

Use this tab to configure the sample clock of the M8195A module. The sample clock for all four Digital to Analog Converters (DAC) of the four channels is identical. The Internal Sample Frequency is derived from a fix Internal Reference clock.

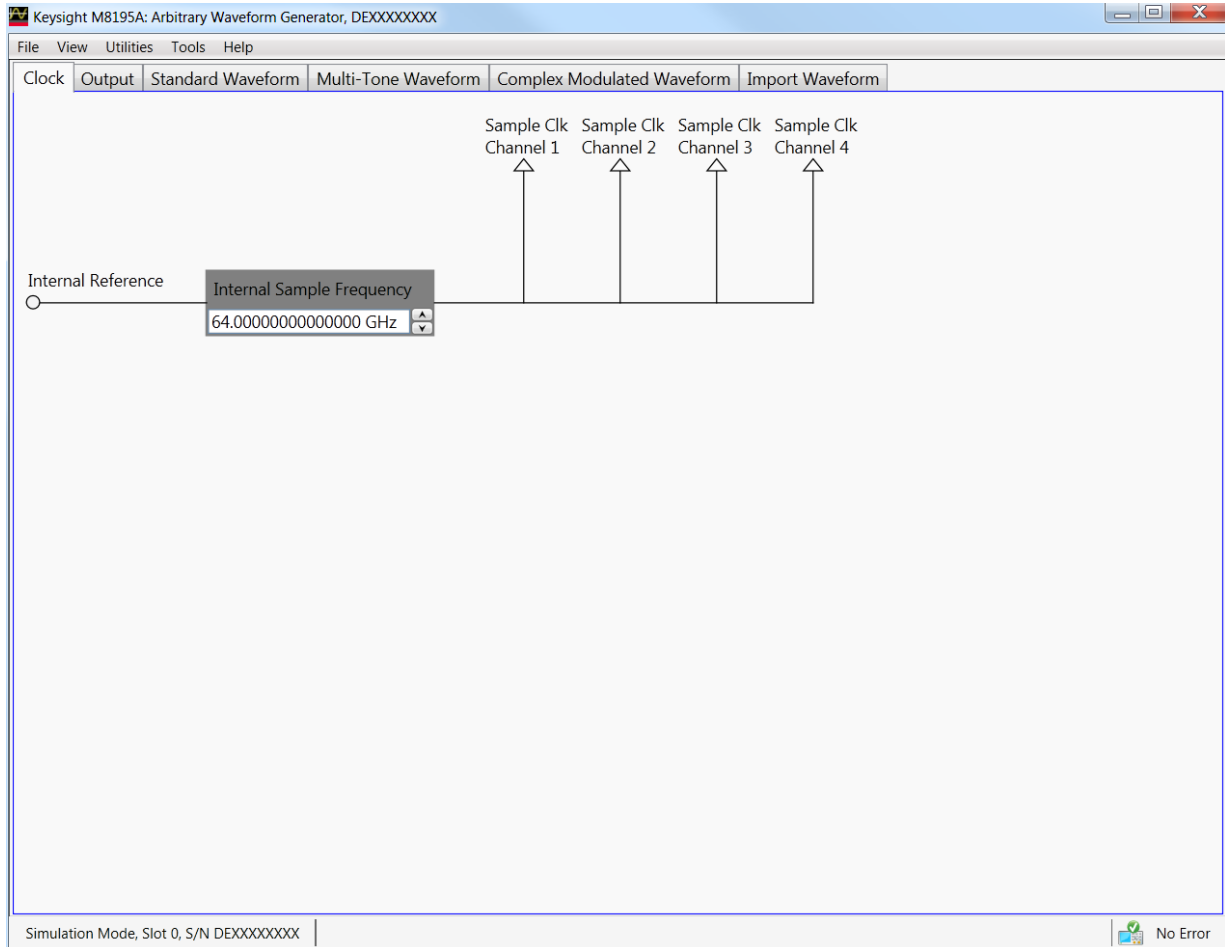

Figure 8: Clock tab

2.7 Output Tab

Use this tab to configure the Data Outputs (Channel 1, Channel 2, Channel 3 and Channel 4) of the M8195A AWG module.

The M8195A has two different Modes of operation:

- Mode: 2 Channel. This mode is always available. If this mode is selected, Channel 1 and Channel 4 are used to generate data. Channel 2 and Channel 3 are powered down and can not be enabled.
- Mode: 4 Channel: This mode is only selectable, if option -R14 is installed. If this mode is selected, all four channels can be used to generate data.

The Run/Stop button is used to switch between Run and Program mode.

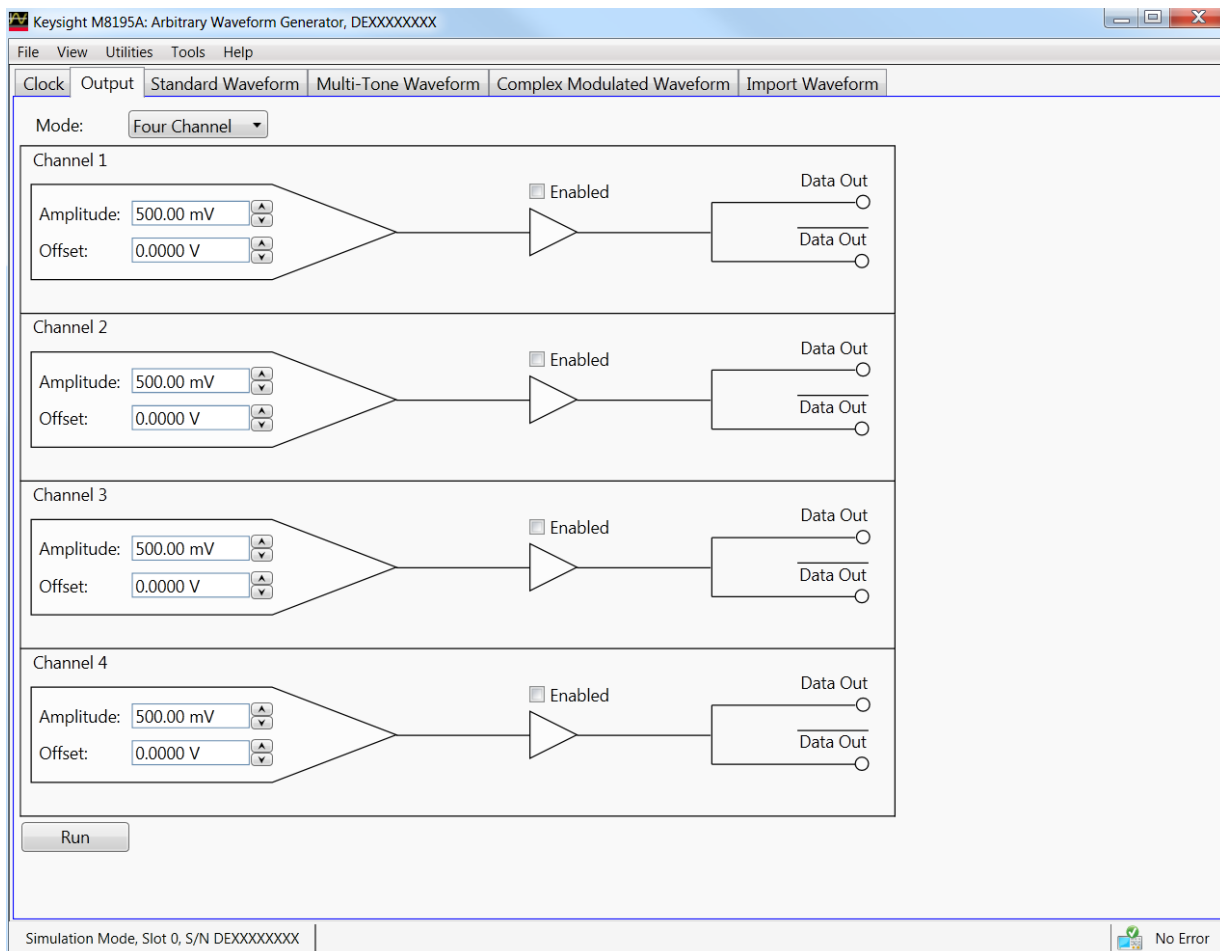

Figure 9: Output tab

Each channel has the following input fields:

- Amplitude
Specifies the amplitude of the output signal.
- Offset
Specifies the offset of the output signal.
- Output status indicator. This indicator reflects the color of the **'Channel'** LED on the front panel:
 - It is 'OFF' when the channel is disabled and no overload condition at this channel has been detected.
 - It is 'GREEN' if the channel is enabled and no overload condition at this channel has been detected.
 - It is 'RED' if the internal protection circuit of that channel has detected an overload condition. Potential overload conditions are e.g. an external short to GND or 50 Ohm termination to a wrong externally applied termination voltage V_{Term} . In case an overload condition is detected, remove the overload condition of the test set-up and enable the channel.
- Output enable switch
If set to enabled position, the generated signal is present at the output.

2.8 Standard Waveform Tab

Use this tab to create a variety of standard waveform types. It provides the controls which allow the complete definition of signal generation parameters for the following waveform shapes:

- Sinusoidal
- Square with linear transitions
- Square with cosine-shaped transitions
- Triangle
- Sinc ($\text{Sin } x/x$)
- Bandwidth-limited Gaussian noise

The standard waveform tab allows you to generate signals for both direct and I/Q data generation modes. It also provides a graphic waveform preview functionality, which can be used to validate created signals before sending them to the instrument. The created signals can also be stored in a file for later use. The application takes care of handling the requirements and limits of the target hardware in aspects such as maximum and minimum record lengths and sampling rate and record length granularity. As a result, the signals designed in this tab will be always feasible to be generated by the instrument and free of distortions such as wrap-around or timing artifacts, even if the signal is generated in looped mode.

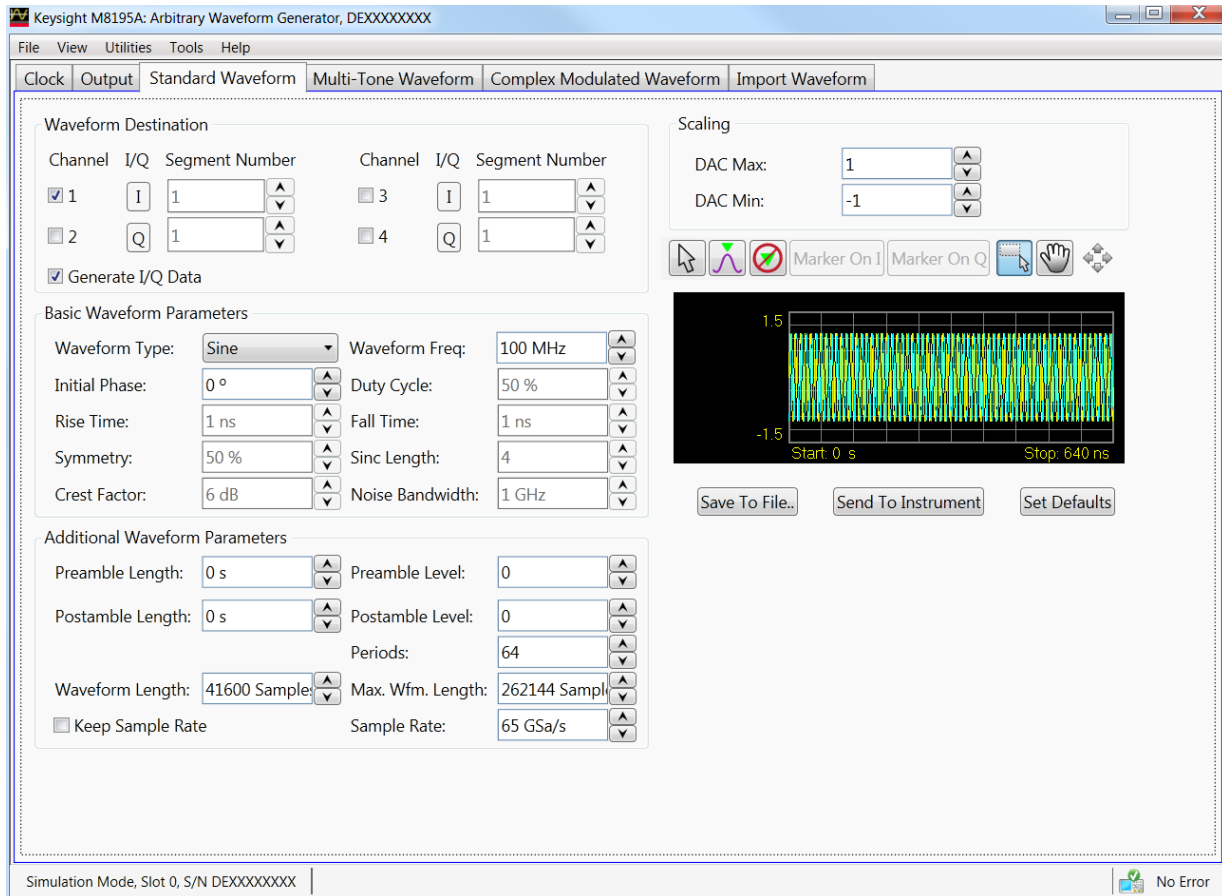

Figure 10: Standard waveform tab

This tab has the following controls:

Waveform Destination Section

- Channel
Independent checkboxes allow the definition of standard waveforms for Channel 1, Channel 2, Channel 3 or Channel 4. One of the boxes is always checked. When pressing the 'Send To Instrument' button, the waveform is sent to all channels that are checked.
- Generate I/Q Data
If checked, baseband (I/Q) signals will be generated. The effect of this control depends on the selected signal type. For Sinusoidal waves, the resulting complex signal will be a single spectral line located at positive or negative frequencies. This implies that users can type negative numbers into the "Waveform Freq." field. For noise, the resulting complex signal will be a limited-bandwidth Gaussian noise with uncorrelated positive and negative frequency components. All the other waveform types result in the same signal being generated by both I and Q assigned channels.
- I/Q Toggle buttons
I/Q selection toggle buttons for each channel will be shown when the Generate I/Q Data checkbox is checked. In-Phase (I) and Quadrature (Q) components can be independently assigned to each channel.
- Segment Number
Target segment for each channel can be defined independently. The segment number is for future use. It is always set to Segment 1.

Basic Waveform Parameters Section

- Waveform Type:

The following waveform types are available:

- Sine: Sinusoidal waveform. Frequency and Initial Phase parameters can be defined for this waveform type using the corresponding controls. If the Generate I/Q checkbox is checked, two sine waves with a 90° phase difference will be assigned to the I and Q components.
- Square_Linear: Square signal with linear transitions. Frequency, Rise Time, Fall Time, Duty Cycle, and Initial Phase parameters can be defined for this waveform type using the corresponding controls.
- Square_Cos: Square signal with cosine shaped transitions. Frequency, Rise Time, Fall Time, Duty Cycle, and Initial Phase parameters can be defined for this waveform type using the corresponding controls.
- Triangle: Triangular waveform with linear transitions. Frequency, Symmetry, and Initial Phase parameters can be defined for this waveform type using the corresponding controls.
- Sinc: Sin x/x waveform. Frequency, Symmetry, Sinc Length, and Initial Phase parameters can be defined for this waveform type using the corresponding controls.
- Noise: Gaussian noise with limited bandwidth. Frequency, Crest Factor, and Noise Bandwidth parameters can be defined for this waveform type using the corresponding controls. If the Generate I/Q checkbox is checked, two uncorrelated noise waveforms will be assigned to the I and Q components.

- Waveform Frequency

Repetition rate for one cycle of the standard waveform. It is always a positive number except when Signal Type is set to Sine and the Generate I/Q Data checkbox is checked. In this case, frequency may be negative so the resulting SSB (Single-Side Band) will be located over or below the carrier frequency.

- Initial Phase

The phase within a normalized cycle of the standard waveform for the first sample in the segment.

- Duty Cycle

The relative width as a percentage of the mark and the space sections of square waves.

- Rise Time
The transition time (10%-90%) for the rising edge in square waveforms.
- Fall Time
The transition time (10%-90%) for the falling edge in square waveforms.
- Symmetry
For both triangular and sinc waveforms, it marks the location as a percentage of the positive highest peak within a period of the basic signal.
- Sinc Length
The number of zero crossings in a single period for the sinc waveform type.
- Crest Factor
The peak-to-average power ratio in dBs for Noise samples before low-pass filtering. Actual crest factor in the final signal after filtering will be higher.
- Noise Bandwidth
Baseband noise bandwidth for Noise waveforms. For IQ modes, noise bandwidth around the carrier frequency will be twice this parameter.

Additional Waveform Parameters Section

- Preamble Length
The duration of a DC section before the defined Standard waveform starts.
- Preamble Level
The level for the DC section before the defined Standard waveform starts. Acceptable range for this parameter is $-1/+1$, being the full dynamic range of the instrument's DAC.
- Postamble Length
The duration of a DC section after the defined Standard waveform stops.
- Postamble Level
The level for the DC section after the defined Standard waveform stops. Acceptable range for this parameter is $-1/+1$, being the full dynamic range of the instrument's DAC.
- Keep Periods
This checkbox is only available when "Keep Sample Rate" is selected. When this option is selected, the waveform calculation algorithm preserves the user-defined number of periods.
- Set WL to Max
This checkbox is only available when "Keep Sample Rate" is selected. When this option is selected, the waveform calculation algorithm always takes the maximum waveform length as defined in the "Max. Wfm. Length". As the waveform length must always be identical for all four channels, it is recommended to check the "Set WL to Max" box in case different waveforms shall be downloaded to different channels.
- Periods
The number of repetition of single periods of the standard waveform within the target segment. This parameter is set automatically when Frequency is changed and preamble and postamble lengths are set to zero in order to

obtain the best timing accuracy and meet the record length granularity requirements.

- **Waveform Length**
The length in samples of the resulting segment. It may be set within acceptable limits and it may be calculated automatically to properly implement other signal and instrument parameters such as sampling rate.
- **Max. Wfm. Length**
Maximum waveform length must be used to force the resulting waveform to be shorter than or equal to a user-set limit.
- **Keep Sample Rate**
This check box preserves the sampling rate to a user-defined value no matter how any other signal parameters may be defined. Keeping the sampling rate to a fixed value may be necessary when multiple waveforms are created to be used in a sequence or scenario. The “Set WL to Max” check box gets activated when this check box is checked.
- **Set WL to Max**
This check box forces the usage of the number of samples defined in the “Max. Wfm. Length” numeric entry field. Some waveform parameters may be adjusted to make sure that continuous play-back of the waveform is seamless.









Scaling Section

- **DAC Max**
Standard waveforms may occupy a limited range of the DAC’s full scale. This parameter sets the maximum level. If set to a lower level than DAC Min, this will be automatically set to the same level. Acceptable range for this parameter is -1/+1, being the full dynamic range of the instrument’s DAC.
- **DAC Min**
Standard waveforms may occupy a limited range of the DAC’s full scale. This parameter sets the minimum level. If set to a higher level than DAC Max, this will be automatically set to the same level. Acceptable range for this parameter is -1/+1, being the full dynamic range of the instrument’s DAC.

Preview Section

- Waveform Preview Toolbar

The waveform preview toolbar includes the icons to preview the waveform. The following icons are available:

	Uses the mouse to control the marker. The respective position of marker at X and Y axis are displayed on the top of waveform.
	Takes the marker to the peak position
	Sets the marker on the I data part of the waveform
	Sets the marker on the Q data part of the waveform
	Turns off the marker
	Provides zoom functionality. Use the mouse pointer to select the area on waveform that you want to zoom. Once done, you can click Auto scale icon to zoom out the waveform.
	Uses the mouse pointer to move the waveform around. You can also use the pan tool when the waveform is zoomed in.
	Auto scale the waveform

- Save To File...

Signals can be stored in files in whether BIN (for non IQ modes) or IQBIN (for IQ modes) formats. These files may be reused within the Import Waveform tab.

- Send To Instrument

Signal will be transferred to the selected segments of the selected channels. The previous running status for the target instrument will be preserved but sampling rate may be modified depending on the waveform requirements.

- Set Default

All the standard waveform parameters are set automatically to their corresponding default values.

2.9 Multi-Tone Waveform Tab

Use this tab to create signals made-up of multiple tones, either equally or arbitrarily spaced. It also allows for the definition of a frequency interval without tones (or notch) for NPR (Noise Power Ratio) testing. Amplitudes and phases of the individual tones can be corrected through correction factor files defined by the user. The Multi-Tone tab allows you to generate both RF and baseband (I/Q Data) signals. It also provides a graphic waveform preview functionality, which can be used to validate the location and amplitudes of the tones in the signal before sending it to the instrument or be stored in a file for later use. The signal's crest factor or Peak-to-Average Power Ratio (PAPR) is also shown. The application handles requirements and limits of the target hardware in aspects such as maximum and minimum record lengths, sampling rate, and record length granularity. As a result, generation of signals designed in this tab will always be feasible through the instrument, and they will be free of distortions such as wrap-around or timing artifacts, even if they are generated in looped mode.

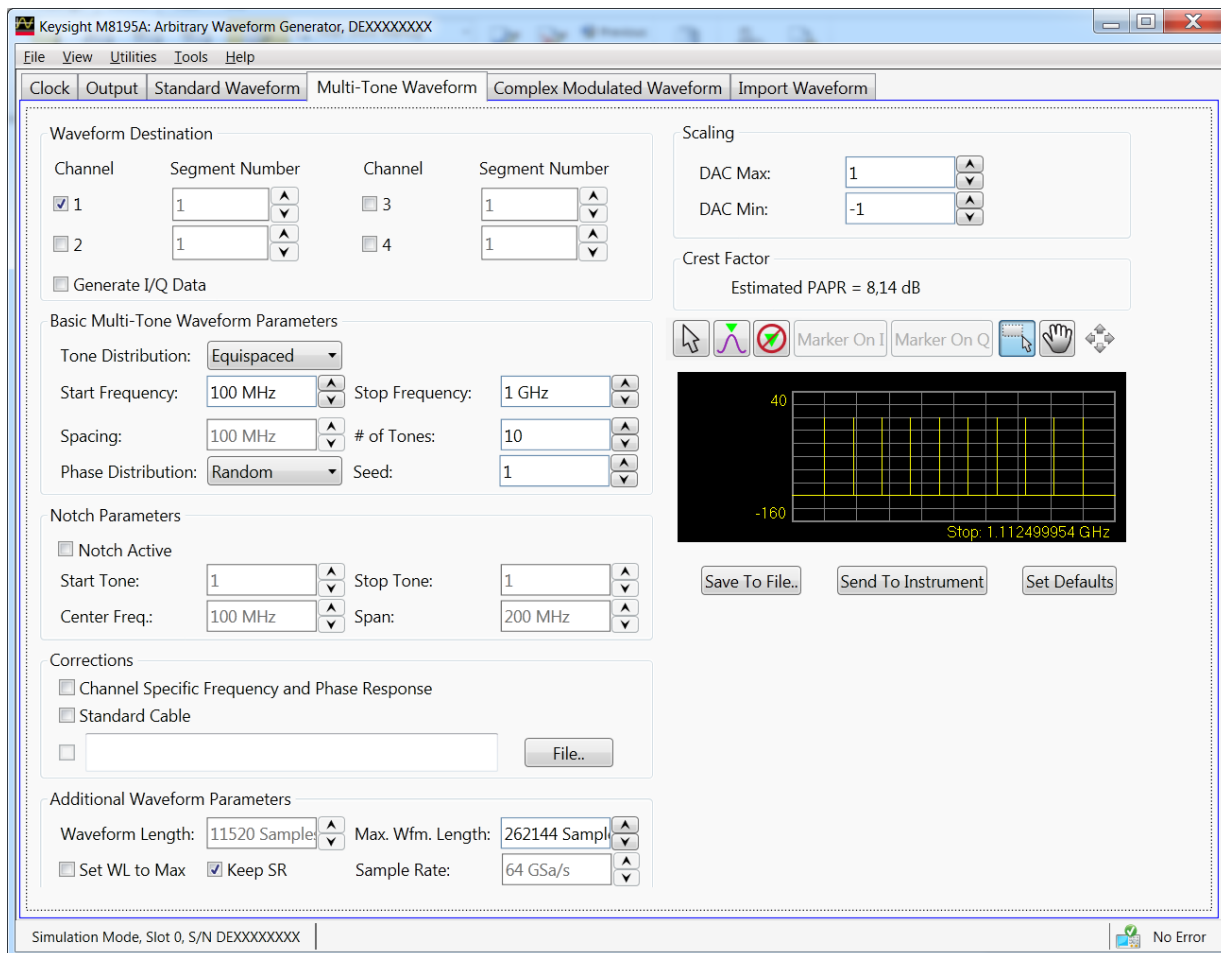

Figure 11: Multi-Tone waveform tab

There are two basic operation modes for the definition of equally spaced or arbitrarily distributed tones respectively. The selection between the two modes is made through the “Tone Distribution” drop-down list. This control affects the contents of the “Basic Multi-Tone Waveform Parameters” section of the user interface and the presence of the “Notch Parameter” section, which only makes sense in case of equally spaced tones.

However, controls in the other control groups are valid and operative for both operating modes. Equally spaced tones are defined on the basis of their common parameters such as start and stop frequencies, and tone spacing or number of tones or both. Arbitrarily distributed tones are defined through a table. In order to simplify the creation of complex scenarios, the tones defined in the equally spaced mode are loaded into the tone table every time the user switches to the arbitrary mode and the tone table is empty. In this way, any number of tones may be easily defined in the equally spaced mode, and then the resulting table may be edited for frequency, amplitude, or phase for each individual tone. Tones may also be deleted or added.

This tab has the following controls:

Waveform Destination Section

- **Generate I/Q Data**
If checked, baseband (I/Q) signals will be generated. The resulting complex signal will be a series of tones located at positive and/or negative frequencies. As a consequence, negative values can be typed into any waveform frequency edition field in this panel when this checkbox is checked.
- **I/Q Toggle buttons**
I/Q selection toggle buttons for each channel will be shown when the Generate I/Q Data checkbox is checked. In-Phase (I) and Quadrature (Q) components can be independently assigned to each channel.
- **Channel Independent checkboxes** allow the definition of Multi-Tone waveforms for Channel 1, Channel 2, Channel 3 or Channel 4. One of the boxes is always checked. When pressing the 'Send To Instrument' button, the waveform is sent to all channels that are checked.
- **Segment Number**
Target segment for each channel can be defined independently. The segment number is for future use. It is always set to Segment 1.

Corrections Section

- **File...**
Open a correction file selection dialog box. Default file extensions match the File Format selection. The name of the successfully loaded correction factors file is shown in the field located at the left of this button. The accepted format for correction files may be found in the [Correction File Format](#) section.
- **Channel Specific Frequency and Phase Response**
This checkbox activates the application of corrections based on frequency-domain calibration data stored in the target instrument in an internal non-volatile memory. It improves flatness and linear phase distortion.
- **Standard Cable**
This checkbox activates the application of correction factors based on a typical high-quality, high-bandwidth 0.85m microwave cable (Huber+Suhner type M8041-61616).

Additional Waveform Parameters Section

- **Waveform Length**
It is indicator only. The length is in samples of the resulting segment.
- **Max. Wfm. Length**
Maximum waveform length must be used to force the resulting waveform to be

shorter than or equal to the limit set by the user.

- **Keep Sample Rate**
This check box preserves the sampling rate to a user-defined value irrespective of the manner in which other signal parameters may be defined. Keeping the sampling rate to a fixed value may be necessary when multiple waveforms are created for usage in a sequence or scenario. The “Set WL to Max” checkbox shows up when this check box is checked.
- **Set WL to Max**
This checkbox is only available when “Keep Sample Rate” is selected. When this option is selected, the waveform calculation algorithm always takes the maximum waveform length as defined in the “Max. Wfm. Length”. As the waveform length must always be identical for all four channels, it is recommended to check the “Set WL to Max” box in case different waveforms shall be downloaded to different channels.
- **Sample Rate**
Final DAC conversion rate for the resulting signal. It may be set by the user or automatically calculated depending on other signal parameters.

Scaling Section

- **DAC Max**
Multi-Tone waveforms may occupy a limited range of the DAC’s full scale. This parameter sets the maximum level. If set to a lower level than DAC Min, this will be automatically set to the same level. Acceptable range for this parameter is $-1/+1$, being the full dynamic range of the instrument’s DAC.
- **DAC Min**
Multi-Tone waveforms may occupy a limited range of the DAC’s full scale. This parameter sets the minimum level. If set to a higher level than DAC Max, this will be automatically set to the same level. Acceptable range for this parameter is $-1/+1$, being the full dynamic range of the instrument’s DAC.

Crest Factor Section

- It is an indicator only.
It shows the estimated PAPR for the current waveform in dB. Although the definition of the PAPR parameter is always the ratio between the peak and the average power for a signal, results change depending on the working mode. For the I/Q Data Generation mode, the result reflects the PAPR of the envelope of the resulting signal while for direct generation it reflects the overall signal. The difference between the former and the latter values is close to +3dBs in most cases.

Preview Section

- **Multi-Tone Preview Toolbar**
The waveform preview toolbar includes the icons that provide different functionality to preview the waveform. For details, see [Preview Section](#)
Waveform Preview ToolbarPreview Toolbar.

Compilation and Panel Control Section

- **Save To File...**
Signals can be stored in files either in BIN (for non IQ modes) or IQBIN (for IQ modes) formats. These files may be reused within the Import Waveform tab.

- **Send To Instrument**
Signal will be transferred to the selected segments of the selected channels. The previous running status for the target instrument will be preserved but sampling rate may be modified depending on the waveform requirements.
- **Set Default**
All the Multi-Tone waveform parameters are set automatically to their corresponding default values. Entries in the Arbitrary Tone table are not modified by this button.

Two control sections show-up for equally spaced tone definition (“Equispaced” selected in the Tone Distribution drop-down list): “Basic Multi-Tone Waveform Parameters” and “Notch Parameters”.

Basic Multi-Tone Waveform Parameters Section

- **Start Frequency**
It is the frequency of the first tone. If it is set to a value higher than the one in the Stop Frequency field, this is changed back to the previous Start Frequency.
- **Stop Frequency**
It is the frequency of the last tone. If it is set to a value lower than the one in the Stop Frequency field, this is changed back to the previous Stop Frequency.
- **Spacing**
It is an indicator only.
$$\text{Spacing} = (\text{Stop Frequency} - \text{Start Frequency}) / (\# \text{ of Tones} - 1).$$
- **# of Tones**
It is the total number of tones in the Multi-Tone signal including the ones in the notch, if any.
- **Phase Distribution**
Phase for each tone can be set in the three different modes: constant, random, and parabolic. While constant phase Multi-Tone signals show a high crest factor, a random phase distribution results in a much lower value for this parameter while a parabolic distribution results in a close to optimal (or minimum) crest factor.
- **Seed**
This parameter is associated to the random phase distribution and allows generating the same or different random sequences for the phases of each tone. It is also useful to look for a distribution resulting in a desired crest factor value.

Notch Parameters Section

- **Notch Active**
This check box activates or deactivates the generation of a notch in the equally spaced Multi-Tone signal.
- **Start Tone**
It is the index of the first tone to be removed in a notch. Acceptable indexes start with 1.
- **Stop Tone**
It is the index of the last tone to be removed in a notch. Acceptable indexes start with 1.
- **Center Frequency**
It is an indicator only. The central frequency for the notch is computed and shown in this field.

- Span
It is an indicator only. The tone-free frequency span for the notch is computed and shown in this field.

Arbitrary Tones Section

Alternatively, an edition table shows-up for arbitrarily spaced tones definition (“Arbitrary” selected in the Tone Distribution drop-down list). When not previously edited (or empty), the table is automatically loaded with the parameters of the tones defined in the equally spaced tone section. This allows for easy edition of individual tones or the creation of multiple notches, or both. Parameters for each tone include its frequency (in Hz), its relative amplitude (in dB), and phase (in degrees). Entries in the table may be added, edited, and deleted. Entries in the table may be also sorted in ascending or descending order of any parameter by clicking in the corresponding field name.

Addition of a new entry in the table must be done by editing the empty edition field located at the bottom of the table. Deletion of any number of entries can be performed by selecting the ones to be deleted and then hitting the key of the keyboard. Meaningful numeric values must be typed into the edition fields. Otherwise an error condition is triggered. While a valid frequency entry must be always entered, any of the amplitude and phase edition fields may kept empty so they take the default values (0.0 dB for Amplitude and 0.0 degrees for Phase).

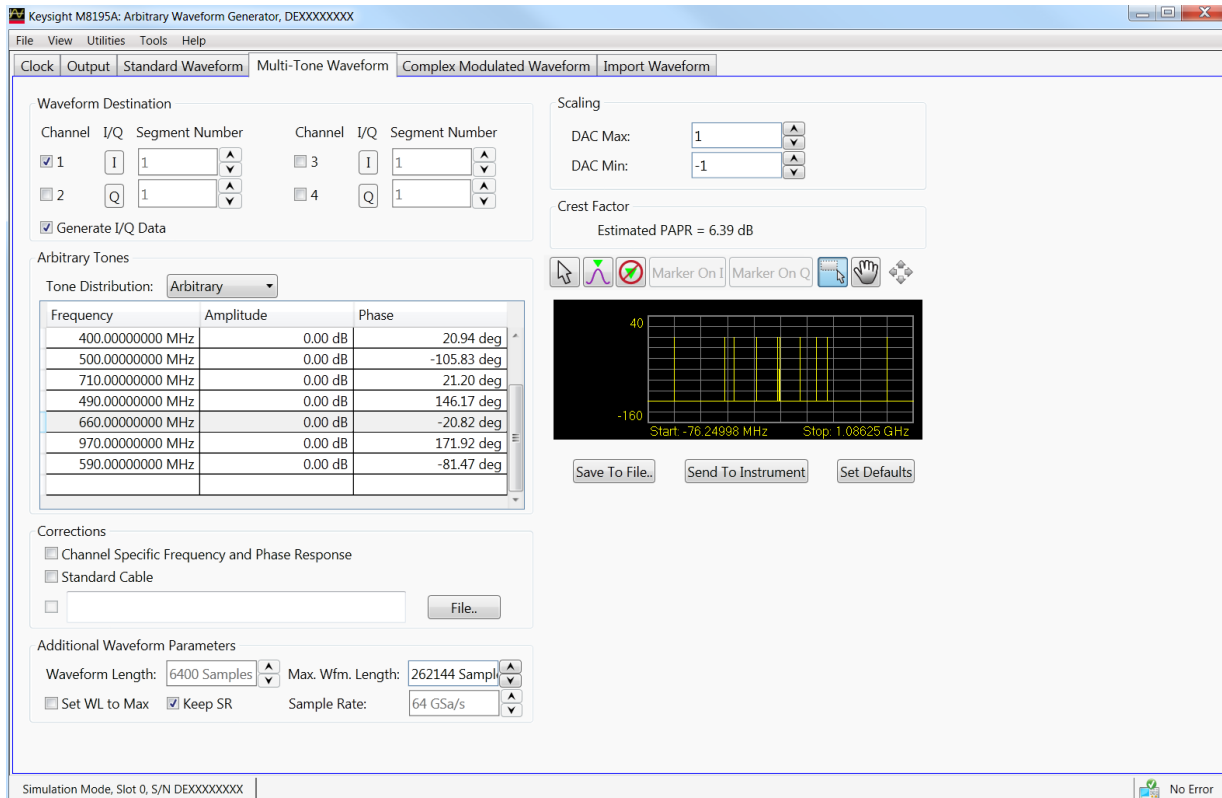

Figure 12: Multi-Tone waveform tab, arbitrary tone distribution

2.10 Complex Modulated Waveform Tab

Use this tab to create baseband and IF/RF digitally modulated signals. User-defined corrections may be applied to signals to compensate for (or emulate) instrument, interconnections and channel linear distortions. The complex modulation tab allows you to generate both RF and Baseband (I/Q) signals. It directly supports a large variety of single-carrier modulation schemes. This is a list of the currently supported standards, modulation orders and modulation parameters:

- ASK (Amplitude Shift Keying): Modulation Index (0%-100%).
- PSK (Phase Shift Keying): BPSK, QPSK, $\pi/4$ -DQPSK, Offset-QPSK (OQPSK), 8PSK, and $3\pi/8$ 8PSK (EDGE).
- QAM (Quadrature Amplitude Modulation): 8QAM, 16QAM, 32QAM, 64QAM, 128QAM, 256QAM, 512QAM, AND 1024QAM.
- MSK (Minimum Shift Keying)
- APSK (Amplitude-Phase Shift Keying): 16APSK and 32 APSK. R2/R1 and R3/R1 can be set by the user to any desired value.
- STAR: STAR16 and STAR32. The R2/R1 parameter may be set for the STAR16 modulation scheme.
- VSB (Vestigial Side Band): 8VSB and 16VSB.
- FSK (Frequency Shift Keying): 2FSK, 4FSK, 8FSK, and 16FSK. Peak deviation frequency may be set by the user to any desired value.
- Custom: Users may define arbitrary constellations through simple ASCII files that may be read by the SFP application. Modulations with offset (Q delayed by half a symbol time) and rotating constellations may be also defined. (Refer to the section [Custom Modulation File Format](#))

Baseband filter type, characteristics, and different data options may be selected by the user. The panel provides a constellation preview functionality, which can be used to validate the selected modulation scheme and the corresponding modulation parameters. The application takes care of handling the requirements and limits of the target hardware with respect to maximum and minimum record lengths, sampling rate, and record length granularity. As a result, generation of the signals designed in this tab will always be feasible by the instrument and free of distortions such as wrap-around or timing artifacts at any signal domain (time, frequency, and modulation), even if the signal is generated in looped mode.

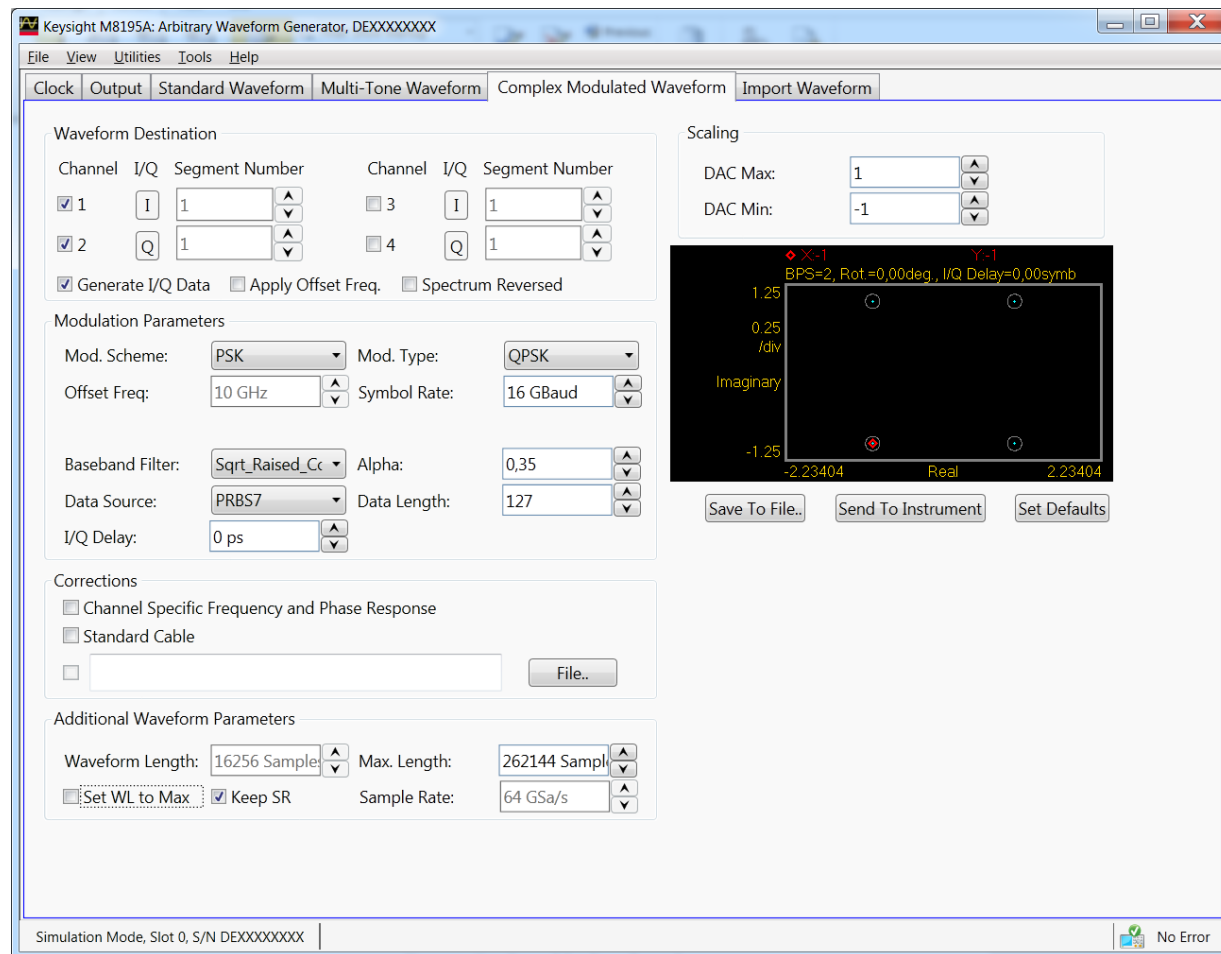

Figure 13: Complex modulated waveform tab

Only relevant parameters and edition fields are shown in the GUI at any time depending on the selected generation mode (RF or I/Q) and modulation scheme.

Waveform Destination Section

- **Generate I/Q Data**
If checked baseband (I/Q) signals will be generated.
- **I/Q Toggle buttons**
I/Q selection toggle buttons for each channel will be shown when the Generate I/Q Data checkbox is checked. In-Phase (I) and Quadrature (Q) components can be independently assigned to each channel.
- **Apply Offset Freq.**
This checkbox is only active for the I/Q Data Generation mode and it applies a frequency shift to the signal according to the 'Offset Freq.' edition field. Frequency shift, unlike carrier frequency, may be positive or negative.
- **Spectrum Reversed**
This checkbox must be selected for generation of signals in the second Nyquist band ($FS/2 - FS$). Its effect is the reversion of the fundamental signal (in the 1st Nyquist Band) in the frequency domain. It also reverses the effect of any correction

so correction factors obtained for the second Nyquist band will be applied appropriately.

- Channel

Independent checkboxes allow the definition of waveforms for Channel 1, Channel 2, Channel 3 or Channel 4.. One of the boxes will be always checked. When pressing the 'Send To Instrument' button, the waveform is sent to all channels that are checked.
- Segment Number

Target segment for each channel can be defined independently. The segment number is for future use. It is always set to Segment 1.

Modulation Parameters Section

- Mod. Scheme

This drop-down list selects the different modulation scheme categories that are supported (see list above).
- Mod. Type/Mod. Order

This drop-down list selects the different modulation orders or modulation scheme sub-types for the selected modulation scheme category.
- Carrier Freq. / Offset Freq.

The purpose and labeling of this edition field changes depending on the generation mode. For the direct RF generation mode, it handles the carrier frequency while for the I/Q Data Generation mode it deals with the offset frequency (see the [Apply Offset Freq.](#) control). Units in both cases are in Hz.
- Symbol Rate

This edition field must be used to enter the signaling speed (or baud rate) for the modulated signal expressed in Bauds (1 Baud = 1 Symbol/s).
- Mod. Index(%)

This edition field only shows up when the ASK modulation scheme is selected. It sets the modulation index as a percentage for the signal.
- R2/R1 Ratio

This edition field only shows up when the 16APSK, 32APSK, and 16STAR modulation schemes are selected. It sets the ratio between the radius of the two inner symbol rings in the constellation.
- R3/R1 Ratio

This edition field only shows up when the 32APSK modulation scheme is selected. It sets the ratio between the radius of the outer and the most internal symbol rings in the constellation.
- Freq. Dev.

This edition field only shows up when the FSK modulation schemes are selected. It sets the peak frequency deviation in Hz.
- Mod. File..

This button only shows up when 'Custom' modulation scheme is selected. It opens a file selection window where modulation definition files may be selected. If a valid file is selected, its name will show up in the text field located at the left of this button. Otherwise a "File Loading Error" message is shown.
- Baseband Filter

This drop-down list can select different baseband filters to be applied to the baseband symbols. Choices are 'None', 'Raised_Cosine', 'Sqrt_Raised_Cosine', 'Gaussian_Dirac', 'Gaussian_Pulse', 'EDGE', and 'Half_Sine'.
- Alpha / BT

The meaning and labeling of this edition field depends on the selected baseband filter. For “Nyquist” filters (Raised Cosine and Square Root of Raised Cosine) it is the ‘Alpha’ parameter (or roll-off factor) of the filter. For Gaussian filters it is the BT (Bandwidth/symbol period product) parameter. Some filter types do not require an additional filter parameter.

- **Data Source**
This drop-down list allows the selection of different pseudo random binary sequences as data sources for modulation. Choices are PRBS7 (Polynomial x^7+x^6+1), PRBS10 (Polynomial $x^{10}+x^7+1$), PRBS11 (Polynomial $x^{11}+x^9+1$), PRBS15 (Polynomial $x^{15}+x^{14}+1$), PRBS23 (Polynomial $x^{23}+x^{18}+1$), PRBS23p (Polynomial $x^{23}+x^{21}+x^{18}+x^{15}+x^7+x^2+1$), and PRBS31 (Polynomial $x^{31}+x^{28}+1$).
- **Data Length**
This edition field may be used to set a given data length to be implemented by the modulated signal. This field defaults to the maximum non-repeating length of the selected PRBS. It also defaults to this value if the user types ‘0’ (Zero). Otherwise the sequence will be truncated when the number of bits set by this control is reached. If this number is longer than the PRBS maximum length, the sequence will be re-started as many times as necessary.
- **I/Q Delay**
This numeric edition field allows for the definition of the time skew between the I and the Q baseband components. It can be used to compensate or emulate timing misalignments caused by cabling, external modulators and other devices. This control is activated only when the Generate I/Q Data checkbox is selected. Delay is applied differentially to both components.
- **Gray Coding**
This checkbox enables gray coding for the applicable modulation modes.

Corrections Section

- **File...**
Opens a correction file selection dialog box. Default file extension is CSV (Comma-Separated Values). The name of the successfully loaded correction factors file is shown in the field located at the left of this button. The accepted format for correction files may be found in the [Correction File Format](#) section.
- **Channel Specific Frequency and Phase Response**
This checkbox activates the application of corrections based on frequency-domain calibration data stored in the target instrument in non-volatile memory. It improves flatness and linear phase distortions.
- **Standard Cable**
This checkbox activates the application of correction factors based on a typical high-quality, high-bandwidth 0.85m cable (Huber+Suhner type M8041-61616)..

Additional Waveform Parameters Section

- **Waveform Length**
It is an indicator only. The length is in samples of the resulting segment.
- **Max. Length**
Maximum waveform length must be used to force the resulting waveform to be shorter or equal to a limit set by the user.
- **Keep Sample Rate**
This check box preserves the sampling rate to a user-defined value irrespective of any other defined signal parameter. Keeping the sampling rate to a fixed value may

be necessary when multiple waveforms are created for usage in a sequence or scenario. The “Set WL to Max” check box gets activated when this check box is checked

- Set WL to Max
This checkbox is only available when “Keep Sample Rate” is selected. When this option is selected, the waveform calculation algorithm always takes the maximum waveform length as defined in the “Max. Wfm. Length”. As the waveform length must always be identical for all four channels, it is recommended to check the “Set WL to Max” box in case different waveforms shall be downloaded to different channels.
- Sample Rate
It is the final DAC conversion rate for the resulting signal. It may be set by the user or automatically calculated depending on other signal parameters.

Scaling Section

- DAC Max
Standard waveforms may occupy a limited range of the DAC’s full scale. This parameter sets the maximum level. If set to a lower level than DAC Min, this will be automatically set to the same level. Acceptable range for this parameter is -1/+1, being the full dynamic range of the instrument’s DAC.
- DAC Min
Standard waveforms may occupy a limited range of the DAC’s full scale. This parameter sets the minimum level. If set to a higher level than DAC Max, this will be automatically set to the same level. Acceptable range for this parameter is -1/+1, being the full dynamic range of the instrument’s DAC.

Constellation Diagram Section

The constellation diagram section shows a graphic representation of the ideal constellation corresponding to the selected modulation scheme and modulation parameters. It also shows the location of symbols from valid modulation definition files for validation. The line above the constellation diagram shows the following modulation parameters:

- BPS (Bits Per Symbol)
- Per symbol rotation angle (in degrees)
- I/Q delay (in symbol times)

Compilation and Panel Control Section

- Save To File...
Signals can be stored in files in whether BIN (for non IQ modes) or IQBIN (for IQ modes) formats. These files may be reused within the Import Waveform tab.
- Send To Instrument
Signal will be transferred to the selected segments of the selected channels. The previous running status for the target instrument will be preserved but sampling rate may be modified depending on the waveform requirements.
- Set Default
All the waveform parameters are set automatically to their corresponding default values.
- Abort
This button allows canceling signal calculation at any moment. It only shows up during signal compilation.

Custom Modulation File Format

A custom modulation file is an ASCII delimited file including all the information required to define a single carrier modulated signal based in quadrature (IQ) modulation. The file must be composed of a header including a series of lines with identifiers and parameters, and a list of numerical correction factors. For lines including more than one item (i.e. one identifier and one parameter), those must be separated using commas. Identifiers and parameters are not case sensitive. These are the significant fields for the header:

- #N: This is a mandatory field and it must be the first in the file. The N parameter is the bits per symbol parameter. $0 < N < 11$.
- Offset: It indicates if the Q component must be delayed by half a symbol time respect to the I component. Accepted parameters are 'yes' or 'no'. This parameter is optional. It defaults to 'no' if not included in the file.
- Rotation: It sets the rotation of the constellation for each consecutive symbol in degrees. This parameter is optional. It defaults to 0.0 if not included in the file.
- RotMode: Rotation mode. Parameter may be 'cont' (continuous) or 'alt' (alternate). This parameter is optional. It defaults to 'cont' if not included in the file.
- Vsb: It indicates that vestigial side band baseband filtering must be applied. Accepted parameters are 'yes' or 'no'. This parameter is optional. It defaults to 'no' if not included in the file.

The order of the above entries is not relevant except for the '#N' field that must be placed first in the file. The symbol location section starts with a line including the 'IQ' characters (not case-sensitive). Entries in this section are made by IQ pairs separated by commas. The number of entries must be at least 2^N although additional entries will be ignored. Data to symbol mapping depends on the order of the symbols in the file so its position expressed in binary format corresponds to the binary code assigned to that symbol. Comments must start with the '/' character sequence and may use a complete line or be located at the end of any valid line (including the first line). Empty lines are also valid.

The following example illustrates a simple example of a 3 bit per symbol QAM8 modulation with a particular constellation.

```
#3 // MyModulationFile
lq
// Inner symbols
2.0, 0.0
0.0, -2.0
-2.0, 0.0
0.0, 2.0
// Outer symbols
3.0, 3.0
-3.0, 3.0
-3.0, -3.0
3.0, -3.0 // Final symbol
```

The above file does not include any unnecessary line in the header as it defines a non-rotating, non-offset modulation so default values for these fields are used instead. The resulting constellation after loading this file is shown as following:

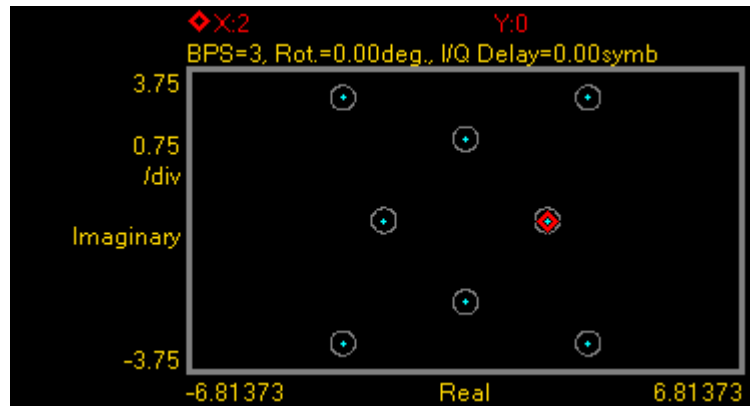

The following example illustrates another possible use of custom modulation to define a distorted constellation. In this particular case, a O-QPSK modulation with a quadrature error (non-perpendicular I and Q axis) is defined:

```
#2
Offset, yes
iq
1.05, 1.05
-0.95, 0.95
-1.05, -1.05
0.95, -0.95
```

The above file includes a line to indicate that this is an offset modulation. The resulting constellation after loading this file is shown as following:



The following is a more complex example:

```
#3
Offset, no
Rotation, 10.0
RotMODE, cont
iq
1.0, 0.0
2.0, 0.0
0.0, 1.0
0.0, 2.0
-1.0, 0.0
-2.0, 0.0
0.0, -1.0
0.0, -2.0
```

The above file is composed of a header with relevant information. In this particular case, the file contains 8 (2^3) IQ pairs. The 'IQ' characters indicate the starting point for the symbol location list composed by 8 lines with I/Q pairs separated by commas. I and Q will not be delayed ('Offset, no') and constellation will rotate by 10.0 degrees ('Rotation, 10.0') in a continuous fashion ('RotMODE, cont'). In fact, the 'Offset' and 'RotMode' fields could be removed without any effect on the final signal as these fields take the default values. The resulting constellation after loading this file is shown as following:

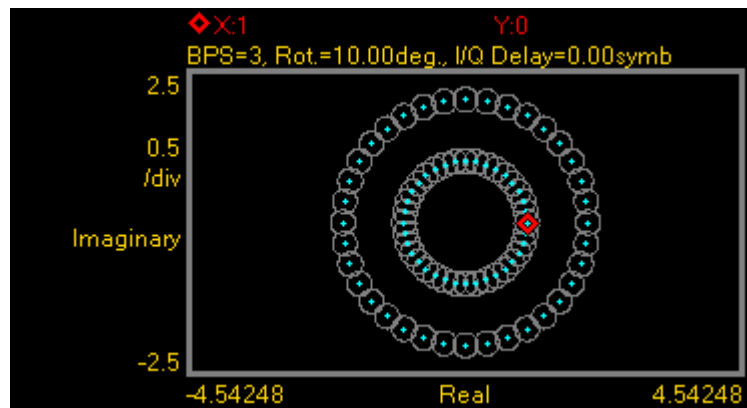

2.11 Import Waveform Tab

Use this tab to perform the functions such as importing, scaling, and resampling waveform files in a variety of formats for their generation by the M8195A arbitrary waveform generator. It provides the controls which allow the complete definition of signal processing parameters for the waveform file format (see [File Format](#)).

Depending on the file format and contents, marker information can be extracted and exported to the M8195A generator. Up to two markers can be supported and assigned to the AWG Sample and Sync markers. Also depending on the file format and contents, information regarding the original sampling rate and/or carrier frequency of the input waveforms can be extracted and re-used within the import tool. Resampling is performed so no images or aliases show up in the resampled waveform.

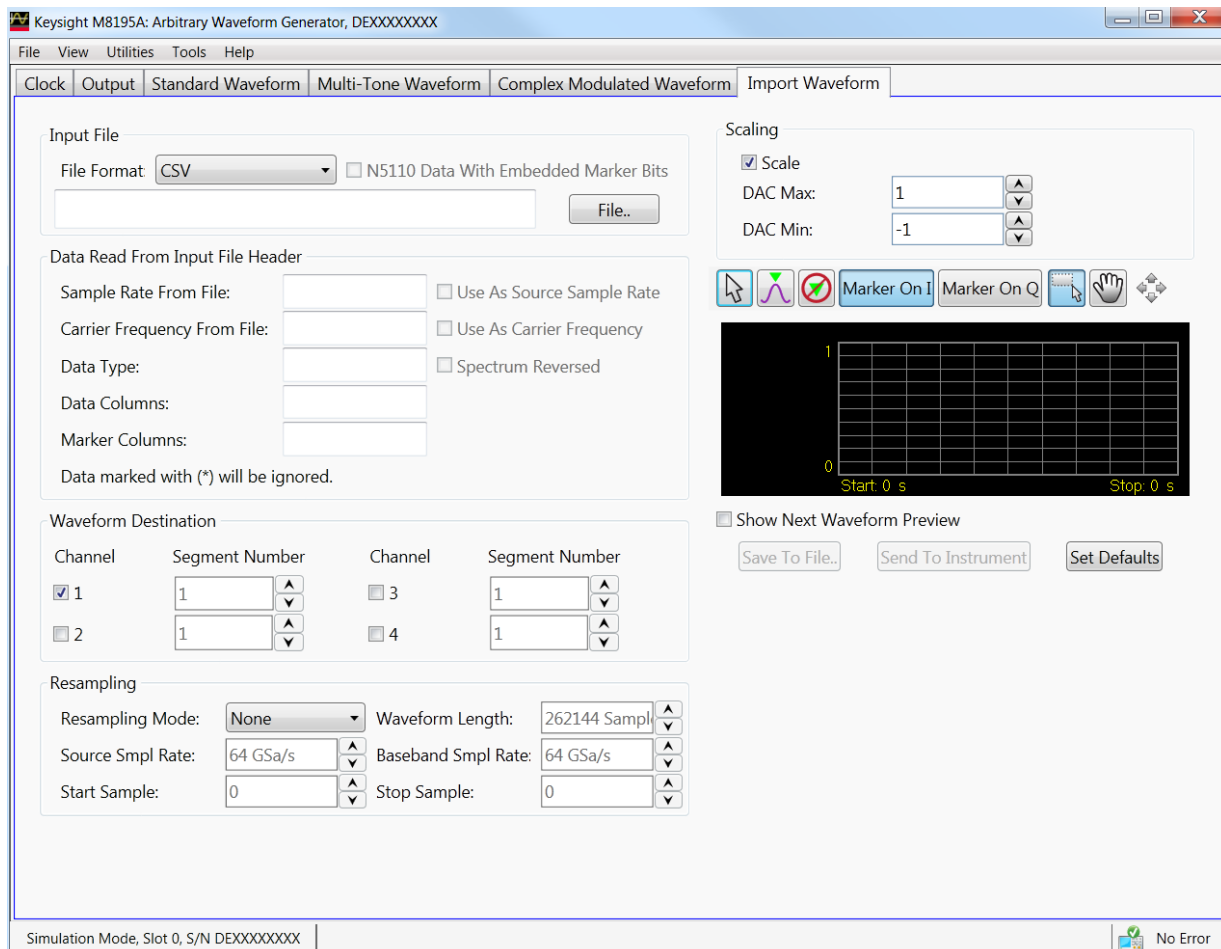

Figure 14: Import waveform tab

This tab has the following controls and indicators:

Input File Section

- File Format

For details on the available file format, see [File Format](#).

Sample waveform data files are available in different formats as listed in the [Table 4](#). The files can be simply imported using the Input File section and can be sent to

the instrument to view the waveform preview. The sample waveform data can be found at the location: **Start > All Programs > Keysight M8195 > Keysight M8195 Examples**

Steps to view the sample data file waveform preview:

- 1 Select the **Show Next Waveform Preview** check box.
- 2 Select the required **File Format** from the drop-down list.
- 3 Click **File...**
- 4 In the **Open** dialog box, select the sample waveform file (as per selected file format)
- 5 Click **Open**.
- 6 Click **Send to Instrument**.

Table 4: Sample waveform data files

File Format	Waveform Data File
TXT	Sin10MHzAt64GHz.txt
BIN	Sin10MHzAt64GHz.bin
BIN8	Sin10MHzAt64GHz.bin8
BIN6030	Sin10MHzAt64GHz.bin6030
BIN5110	SinDelta10MHzIQ.bin5110
IQBIN	SinDelta10MHzIQ.iqbin
MAT89600	Sin10MHzAt64GHz.mat89600
CSV	Sin10MHzAt64GHz.csv
DSA90000	Sin10MHzAt64GHz.dsa90000

- **N5110 Data With Embedded Marker Bits**
This checkbox is only enabled, if the File Format is BIN5110. If checked, the BIN5110 format with 14-bit data for I and Q and embedded marker bits is used. If unchecked, the BIN5110 format with 16-bit data for I and Q and no marker bits is used.
- **File...**
Open a file selection dialog. Default file extensions match the File Format selection. Successful loading of a waveform updates multiple information fields through the panel reflecting the waveform settings and a graph of the waveform is shown in the preview display.

Data Read From Input File Header Section

- **Sample Rate From File**
Indicator only. It shows the input waveform sample rate, if any, contained in the loaded file. If no sample rate is specified “n.a.” (not available) is shown.
- **Use As Source Sample Rate**
This checkbox assigns the sample rate specified in the file as the Source Sample Rate used for resampling.
- **Carrier Frequency From File**
Indicator only. It shows the input waveform carrier frequency, if any, contained in the loaded file. If no carrier frequency is specified “n.a.” (not available) is shown.
- **Data Type**
This is the organization of samples within the file. It may be Single (real-only waveform) or IQ (complex waveforms).
- **Spectrum Reversed**

This checkbox is only active for complex (IQ) waveforms. It results in an imported signal which is the complex conjugate of the input signal, thus its spectrum will be reversed.

- Data Columns
It shows the internal organization of the file regarding waveforms. It can show from one column (Y1) up to 4 (Y1, Y2, Y3*, Y4*).
- Marker Columns
It shows the internal organization of the file regarding markers. It can show from one column (M1) up to 4 (M1, M2, M3*, M4*).

Waveform Destination Section

- Channel
Independent checkboxes allow for the definition of Multi-Tone waveforms for Channel 1, Channel 2, Channel 3 or Channel 4. One of the boxes is always checked. When pressing the 'Send To Instrument' button, the waveform is sent to all channels that are checked.
- I/Q Toggle buttons
I/Q selection toggle buttons for each channel will be shown when the a file containing an I/Q waveform is selected for import. In-Phase (I) and Quadrature (Q) components can be independently assigned to each channel.
- Segment Number
Target segment for each channel can be defined independently. The segment number is for future use. It is always set to Segment 1.

Resampling Section

- Resampling Mode
It controls the way waveforms are imported and resampled. Please refer to the description of the [Resampling Methodology](#) in the Appendix chapter. The following modes are available:
 - None: Baseband Sample Rate will be the same as the Source Sampling Rate. The output waveform will use the same number of samples as the selected portion of the input waveform. Granularity requirements will be met by repeating the basic waveform the minimum number of times so the combined length is a multiple of the granularity for the current DAC mode.
 - Timing: The time window of the input signal (Waveform Length / Sample Rate) will be used to calculate the best value for the output record length being a multiple of the granularity for the current DAC mode according to the output sampling rate defined by the user. Final output sampling rate will be slightly adjusted to accurately keep the timing of the original signal.

- Output_SR: The user-defined output sampling rate will be used to calculate the best value for the output record length being a multiple of the granularity for the current DAC mode according to the time window of the input signal. Final time window will be slightly adjusted to keep the selected output sampling rate. This change is reflected in the Source Sampling Rate numeric entry field value.
 - Output_RL: The user-defined output Waveform Length will be used to calculate the best value for the output Sample Rate according to the time window of the input signal. Waveform Length will be adjusted to the nearest multiple of the granularity for the current DAC mode according to the time window of the input signal.
 - Zero_Padding: Output Waveform Length is calculated based on the input waveform time window and the user-defined output sampling rate. The resulting waveform length will not be, in general, a multiple of the granularity. To meet the granularity conditions, a number of zero samples are added until the combined number of samples is a multiple of the granularity. Output Sample Rate will be slightly adjusted to keep the input waveform time window.
 - Truncate: Output Waveform Length is calculated based on the input waveform time window and the user-defined output sampling rate. The resulting waveform length will not be, in general, a multiple of the granularity. To meet the granularity conditions, a number of samples is removed until the resulting number of samples is a multiple of the granularity. Output Sample Rate will be slightly adjusted to keep the input waveform time window.
 - Repeat: Output Waveform Length is calculated based on the input waveform time window and the user-defined output sampling rate. The resulting waveform length will not be, in general, a multiple of the granularity. To meet the granularity conditions, the base waveform is repeated the minimum number of times so the overall number of samples is a multiple of the granularity. Output Sample Rate will be slightly adjusted to keep the input waveform time window. The Waveform Length field will show the length of the combined waveform.
- Waveform Length
It shows the number of samples of the resampled output waveform. It can be set when Resampling Mode is Output_RL. Otherwise, this field is an indicator.
 - Source Sample Rate
The speed at which samples in the input waveform are sampled. It can be set by typing a valid value unless the "Use As Source Sample Rate" checkbox is checked. In this particular case, the sampling rate information contained in the input waveform file will be always used.
 - Baseband Sample Rate
The speed at which samples in the output waveform will be converted. It can be set in all Resampling Modes except for the Output_RL mode.
 - Start Sample
This field can be used to select the starting sample of the section of the input waveform to be imported. It cannot be set to a value higher than the Stop Sample.
 - Stop Sample
This field can be used to select the final sample of the section of the input waveform to be imported. It cannot be set to a value lower than the Start Sample.
 - Scale
This checkbox controls the way the input output waveform will be scaled after resampling. If unchecked, the output waveform samples will not be re-scaled.

Sample levels over +1.0 or under -1.0 will be clipped.

Scaling Section

- **DAC Max**
Imported waveforms may occupy a limited range of the DAC's full scale. This parameter sets the maximum level. If set to a lower level than DAC Min, this will be automatically set to the same level. Acceptable range for this parameter is -1/+1, being the full dynamic range of the instrument's DAC.
- **DAC Min**
DAC Max: Imported waveforms may occupy a limited range of the DAC's full scale. This parameter sets the minimum level. If set to a higher level than DAC Max, this will be automatically set to the same level. Acceptable range for this parameter is -1/+1, being the full dynamic range of the instrument's DAC.

Preview Section

- **Waveform Preview Toolbar**
The waveform preview toolbar includes the icons which provide different functionality to preview the waveform. For details, see [Preview Section Waveform Preview Toolbar](#).
- **Show Next Waveform Preview**
This checkbox affects the behavior of the preview for the next waveform. If selected, a preview of the imported waveform is displayed. Leave this checkbox unselected to speed up the import of large waveforms.
- **Save To File...**
Signals can be stored in files in whether BIN (for non IQ modes) or IQBIN (for IQ modes) formats. These files may be reused within the Import Waveform tab.
- **Send To Instrument**
Signal will be transferred to the selected segments of the selected channels. The previous running status for the target instrument will be preserved but sampling rate may be modified depending on the waveform requirements.
- **Set Default**
All the imported waveform parameters are set automatically to their corresponding default values.

2.12 Correction File Format

A correction file is an ASCII delimited file carrying all the information required to compensate or embed a given frequency response in the multi-tone or complex modulation signal. The file must be composed of a header including a series of lines with identifiers and parameters, and a list of numerical correction factors. In lines including more than one item (i.e., one identifier and one parameter), the items must be separated using commas. Identifiers and parameters are not case sensitive.

These are the significant fields for the header:

- **InputBlockSize:** It states the number of valid correction factors in the file. It is a mandatory field.
- **XStart:** It is frequency in Hz corresponding to the first entry in the correction factor section of the file. It is a mandatory field for multi-tone generation in direct mode and optional for multitone in upconverter mode and complex modulation.
- **XDelta:** It is frequency distance in Hz between consecutive entries in the correction factor section of the file. It is a mandatory field.
- **YUnit:** Units for the amplitude values in the correction factor section of the file. Parameter associated to it may be 'dB' (for logarithmic relative amplitudes) or 'lin' (for dimensionless linear relative amplitude). This parameter is optional and its default value is 'lin'. Phase unit must be always stated in radians.

The order of the above entries is not relevant. The correction factor section starts with a line including a single 'y' or 'Y' character. Entries in this section are made by Amp1(Fi), Phase1(Fi) pairs. In particular, this format is compatible with adaptive equalizer files exported in comma-separated value (CSV) format from the Keysight 89600 VSA software package. These files reflect the channel response corrected by the equalizer so they should be applied through the selection of the 'Channel_Response' option in the corresponding 'CorrectionMode' drop-down list in the 'Corrections' section of the 'Multi-Tone' or 'Complex Modulation' panel, respectively. Comments must start with the '/' character sequence and may use a complete line or be located at the end of any valid line. Empty lines are also valid.

This is an example correction file:

```
// MyCorrectionFile
InputBlockSize, 1024
XStart, 1.0E+09 // 1.0GHz
XDelta, 1.0E+06
YUnit, lin
Y
0.987, -0.2343
0.995, 0.5674
...
...
1.269, -0.765
```

The above files are composed of a header with relevant information. In these particular cases, the files contain 1024 linear correction factors spaced by 1 MHz and starting at 1 GHz. The 'Y' character indicates the starting point for the correction factor list composed of 1024 lines with amplitude/phase pairs separated by commas. For one-channel files there is a amplitude/phase pair per line while for two channel files there are two pairs (Amp1, Phase1, Amp2, Phase2).

The way this information is applied by the Soft Front Panel software depends on the signal generation mode and the signal category. For direct conversion multi-tone RF generation modes ('Generate IQ Data' unchecked), corrections are applied directly to the tones based on their absolute frequency. For up-converted multi-tone baseband generation (I/Q) modes ('Generate IQ Data' checked), corrections are applied to the complex baseband signals. So, the internal or external carrier frequency is represented by the central entry in the list (i.e., entry #512 in the 1024 entries example shown above) regardless of the 'XStart' parameter. For Complex Modulated waveforms, corrections are always applied to the complex baseband signals regardless of the 'Generate IQ Data' checkbox setting so, as it happens with the correction of multi-tone baseband signals, the internal or external carrier frequency is represented by the central entry in the list.

3 General Programming

- 3.1 Introduction / 57
- 3.2 IVI-COM Programming / 58
- 3.3 SCPI Programming / 59
- 3.4 Programming Recommendations / 62
- 3.5 System Related Commands (SYSTEM Subsystem) / 63
- 3.6 Common Command List / 69
- 3.7 Status Model / 72
- 3.8 :ARM/TRIGger Subsystem / 82
- 3.9 :INSTrument Subsystem / 82
- 3.10 :MMEMory Subsystem / 84
- 3.11 :OUTPut Subsystem / 91
- 3.12 Sampling Frequency Commands / 92
- 3.13 :VOLTage Subsystem / 93
- 3.14 Frequency and Phase Response Data Access / 95
- 3.15 :TRACe Subsystem / 95
- 3.16 :TEST Subsystem / 113

3.1 Introduction

Introduction

The M8195A can be programmed like other modular instruments using IVI-COM driver. In addition classic instrument programming using SCPI commands is supported.

The following picture gives an overview about how things work together:

NOTE

Programming using IVI-COM driver is not supported in revision 1.

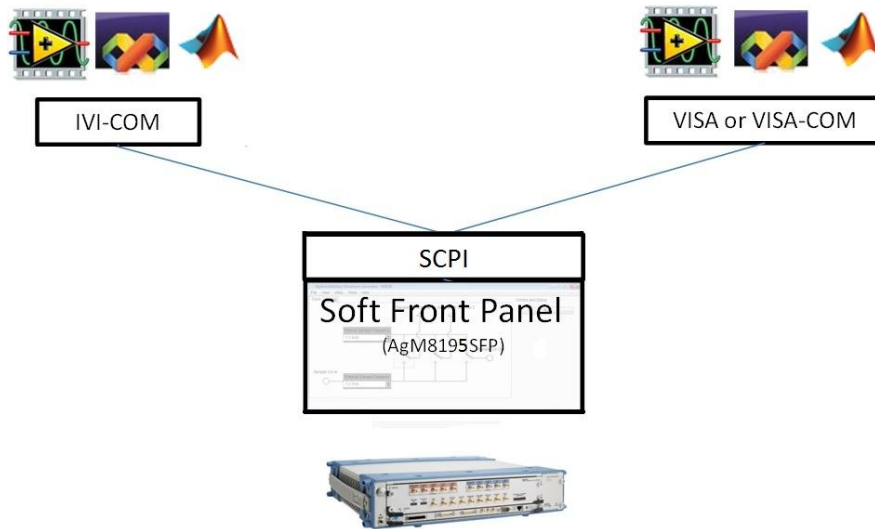

Figure 15: M8195A programming

The Soft Front Panel talks to the actual M8195A module using a PCI express or USB connection. I/O to the module is done using VISA library of Keysight I/O library. Addressing is done with PXI resource strings, e.g. "PXI36::0::0::INSTR" or USB resource strings, e.g. "USB-PXI0::5564::4819::DE00000001::INSTR". The purpose of the Soft Front Panel is to provide a classic instrument like SCPI interface that is exposed via LAN.

IVI-COM wraps the SCPI commands into an API based programming model. To select what module is programmed, the resource string of the module is used. The IVI-driver will automatically locate an already running Soft Front Panel that is handling the module. If no such Soft Front Panel exists, it is started automatically. This way it is completely hidden that the IVI driver actually needs the Soft Front Panel for programming the M8195A module.

VISA or VISA-COM are libraries from an installed I/O library such as the Keysight I/O library to program the instrument using SCPI command strings. The Soft Front Panel must be already running to connect to it.

The Soft Front Panel is also providing the user interface. It is used for interactively changing settings. In addition, it can log what IVI or SCPI calls need to be done when changing a setting. This can be activated with *Tools* → *Monitor Driver calls...* In addition, you can verify changes done from a remote program.

3.2 IVI-COM Programming

The recommended way to program the M8195A module is to use the IVI drivers. See documentation of the IVI drivers how to program using IVI drivers. The connection between the IVI-COM driver and the Soft Front Panel is hidden. To address a module therefore the PXI or USB resource string of the module is used. The IVI driver will connect to an already running Soft Front Panel. If the Soft Front Panel is not running, it will automatically start it.

3.3 SCPI Programming

Introduction

In addition to IVI programming SCPI programming using a LAN connection is also supported. Three LAN protocols are supported. The correct resource strings are shown in the Soft Front Panel's About window. A context menu is provided to copy the resource strings.

- **VXI-11:** The Visa resource string is e.g. "TCPIP0::localhost::inst0::INSTR".
- **HiSLIP:** This protocol is recommended. It offers the functionality of VXI-11 protocol with better performance that is near socket performance. Visa resource strings look like "TCPIP0::localhost::hislip0::INSTR". To use the HiSlip protocol an I/O library such as the Keysight I/O Libraries Suite must be installed. Since the protocol is new it might not be supported by the installed I/O library. The Keysight I/O Libraries Suite 16.3 and above supports it. However, the Keysight I/O Libraries Suite might be installed as secondary I/O library. In this case, check if the primary I/O library supports HiSLIP. If it does not, the socket protocol must be used.
- **Socket:** This protocol can be used with any I/O library or using standard operating system socket functionality connecting to port 5025. This protocol must be used if the used I/O library is not supporting HiSLIP protocol. Visa resource string looks like "TCPIP0::localhost::5025::SOCKET", the exact resource string can be seen in the Ag8195 Soft Front Panel main window.

NOTE

AgM8195SFP.exe must be started prior to sending SCPI to the instrument. (See [AgM8195SFP.exe](#))

3.3.1 AgM8195SFP.exe

Before sending SCPI commands to the instrument, the Soft Front Panel (AgM8195SFP.exe) must be started. This can be done in the Windows Start menu (Start > All Programs > Keysight M8195 > Keysight M8195 Soft Front Panel).

3.3.1.1 Command Line Arguments

(See [Communication](#) for details about /Socket, /Telnet, /Inst, /AutoID, /NoAutoID, /Fallback).

Table 5: Command line arguments

Option	Description
/Socket socketPort	Set the socket port at which the Soft Front Panel waits for SCPI commands
/Telnet telnetPort	Set the telnet port at which the Soft Front Panel waits for SCPI commands
/Inst instrumentNumber	Set the instrument number (instN, hislipN) at which the Soft Front Panel waits for SCPI commands
/AutoID	Automatically select ports and number for the connections (default behavior).
/NoAutoID	Disable the default behavior; i.e. do not automatically select ports and number for the connections.
/Fallback	Try to find unused ports and number if starting a server fails.
/NoSplash	Don't show the splash screen.
/r resourceName	Visa PXI resource string of the module to connect to, e.g. PXI12::0::0::INSTR

3.3.1.2 Communication

Depending on the command line arguments `/Socket`, `/Telnet`, `/Inst`, `/AutoID`, `/NoAutoID`, `/Fallback`, the Soft Front Panel starts several servers to handle SCPI commands. (Refer to the table above.)

`/Socket`, `/Telnet`, `/Inst`: If -1, don't start the respective servers

- Defaults:
 - Socket port: 5025 (e.g. TCPIP0::localhost::5025::SOCKET)
 - Telnet port: 5024

HiSLIP, VXI-11.3: 0 (e.g. TCPIP0::localhost::hislip0::INSTR,
TCPIP0::localhost::inst0::INSTR)

`/Fallback` : If starting a server fails because of a conflict, try using another port or number

- HiSLIP, VXI-11.3: increase the index until a server can be started successfully
- Socket, Telnet: start with port 60000, then increase it until the servers can be started successfully. If neither socket nor telnet is disabled the Soft Front Panel tries to start the servers on two consecutive ports (socket port = telnet port + 1)

`/AutoID` : Automatically select ports and number for the connections, which are unique per instrument.

- This is the default behavior; it is not necessary to specify this argument on the command line.
- If only one AXIe module is connected to this PC and it is an M8195 module, first try to use the command line arguments `/Socket`, `/Telnet`, `/Inst`, or their respective default values if they are not specified. If starting the servers fails, proceed with the steps below.
- `/Socket`, `/Telnet`, `/Inst` are ignored (unless they are -1 and a server is disabled)
- If the Soft Front Panel detects more than one AXIe module, use a special mechanism to obtain a number for the HiSLIP and VXI-11.3 servers, which makes sure that the Soft Front Panel uses always the same VISA resource string per module
- The socket and telnet port are then calculated from the HiSLIP index:
 - telnet port = 60000 + 2 * <HiSLIP index>
 - socket port = 60000 + 2 * <HiSLIP index> + 1

Note: Ports may already be in use by Windows or other applications, so they are not available for M8195A.

`/NoAutoID` : Do not automatically select ports and number for the connections, use the values specified with `/Socket`, `/Telnet`, `/Inst` or their respective default values instead.

If both `/NoAutoID` and `/AutoID` are specified, `/AutoID` overrides `/NoAutoID`.

NOTE

The first port not assigned by IANA is 49152 (IANA, Internet Assigned Numbers Authority, <http://www.iana.org>)

3.4 Programming Recommendations

This section lists some recommendations for programming the instrument. Start programming from the default setting. The common command for setting the default setting is:

```
*RST
```

Use the binary data format when transferring waveform data.

The SCPI standard defines a long and a short form of the commands. For fast programming speed, it is recommended to use the short forms. The short forms of the commands are represented by upper case letters. For example the short form of the command to set 10mV offset is:

```
:VOLT:OFFS 0.01
```

To improve programming speed it is also allowed to skip optional subsystem command parts. Optional subsystem command parts are depicted in square brackets, e.g.: Set amplitude `[:SOURCE] :VOLTage [1 | 2] [:LEVel] [:IMMediate] [:AMPLitude]`

Sufficient to use:

```
:VOLT
```

M8195A is a 4 channel instrument. Parameters have to be specified for output 1, 2, 3, and 4. If there is no output specified the command will set the default output 1. So, for setting an offset of 10mV for output 1 and output 2 the commands are:

```
:VOLT:OFFS 0.01 # sets offset of 10mV at output 1
```

```
:VOLT1:OFFS 0.01 # sets offset of 10mV at output 1
```

```
:VOLT2:OFFS 0.01 # sets offset of 10mV at output 2
```

If it is important to know whether the last command is completed then send the common query:

```
*OPC?
```

It is recommended to test the new setting which will be programmed on the instrument by setting it up manually. When you have found the correct setting, then use this to create the program.

In the program it is recommended to send the command for starting data generation (:INIT:IMM) as the last command. This way intermediate stop/restarts (e.g. when changing sample rate or loading a waveform) are avoided and optimum execution performance is achieved.

```
*RST          # set default settings
...           # other commands to set modes
...           # and parameters
:OUTP1 ON    # enable the output 1
:INIT:IMM    # start data generation.
```

3.5 System Related Commands (SYSTEM Subsystem)

3.5.1 :SYSTEM:ERRor[:NEXT]?

Command	:SYST:ERR?
Long	:SYSTEM:ERRor?
Parameters	None
Parameter Suffix	None
Description	<p>Read and clear one error from the instrument's error queue.</p> <p>A record of up to 30 command syntax or hardware errors can be stored in the error queue. Errors are retrieved in first-in-first-out (FIFO) order. The first error returned is the first error that was stored. Errors are cleared as you read them.</p> <p>If more than 30 errors have occurred, the last error stored in the queue (the most recent error) is replaced with "Queue overflow". No additional errors are stored until you remove errors from the queue.</p> <p>If no errors have occurred when you read the error queue, the instrument responds with 0, "No error".</p> <p>The error queue is cleared by the <i>*CLS</i> command, when the power is cycled, or when the Soft Front Panel is re-started.</p> <p>The error queue is not cleared by a reset (<i>*RST</i>) command.</p> <p>The error messages have the following format (the error string may contain up to 255 characters):</p> <p>error number,"Description", e.g.</p> <p>-113,"Undefined header".</p>
Example	<p>Query</p> <p>:SYST:ERR?</p>

3.5.2 :SYSTEM:HELP:HEADers?

Command	:SYST:HELP:HEAD?
Long	:SYSTEM:HELP:HEADers?
Parameters	None
Parameter Suffix	None

Description

The HEADers? query returns all SCPI commands and queries and IEEE 488.2 common commands and common queries implemented by the instrument. The response is a <DEFINITE LENGTH ARBITRARY BLOCK RESPONSE DATA> element. The full path for every command and query is returned separated by linefeeds. The syntax of the response is defined as: The <nonzero digit> and sequence of <digit> follow the rules in IEEE 488.2, Section 8.7.9. A <SCPI header> is defined as: It contains all the nodes from the root. The <SCPI program mnemonic> contains the node in standard SCPI format. The short form uses uppercase characters while the additional characters for the long form are in lowercase characters. Default nodes are surrounded by square brackets ([]).

Example

Query
:SYST:HELP:HEAD?

3.5.3 :SYSTem:LiCense:EXTEnded:LIST?

Command	:SYST:LiC:EXt:LIST?
Long	:SYSTem:LiCense:EXTEnded:LIST?
Parameters	None
Parameter Suffix	None
Description	This query lists the licenses installed.
Example	Query :SYST:LiC:EXt:LIST?

3.5.4 :SYSTem:SET[?]

Command	:SYST:SET[?]
Long	:SYSTem:SET[?]
Parameters	<binary block data>
Parameter Suffix	None
Description	In query form, the command reads a block of data containing the instrument's complete set-up. The set-up information includes all parameter and mode settings, but does not include the contents of the instrument setting memories or the status group registers. The data is in a binary format, not ASCII, and cannot be edited. In set form, the block data must be a complete instrument set-up read using the query form of the command. This command has the same functionality as the *LRN command.
Example	Command :SYST:SET <binary block data> Query :SYST:SET?

3.5.5 :SYSTem:VERSiOn?

Command	:SYST:VERS?
Long	:SYSTem:VERSiOn?
Parameters	None

Parameter Suffix	None
Description	This query returns a formatted numeric value corresponding to the SCPI version number for which the instrument complies.
Example	Query :SYST:VERS?

3.5.6 :SYSTEM:COMMunicate:*?

Command	:SYST:COMM:*?
Long	:SYSTEM:COMMunicate:*?
Parameters	None
Parameter Suffix	None
Description	<p>These queries return information about the instrument Soft Front Panel's available connections. If a connection is not available, the returned value is -1.</p> <p>This is only useful if there is more than one Keysight module connected to a PC, otherwise one would normally use the default connections (HiSLIP and VXI-11 instrument number 0, socket port 5025, telnet port 5024)</p> <p>One can never be sure if a socket port is already in use, so one could e.g. specify a HiSLIP number on the command line (<i>AgM8195SFP.exe /AutoID /Inst5 /Fallback /r ...</i>) and let the Soft Front Panel find an unused socket port. Then this socket port can be queried using the HiSLIP connection.</p>
Example	Query :SYST:COMM:*?

3.5.6.1 :SYSTem:COMMunicate:INSTr[:NUMBer]?

Command	:SYST:COMM:INST?
Long	:SYSTem:COMMunicate:INSTr?
Parameters	None
Parameter Suffix	None
Description	This query returns the VXI-11 instrument number used by the Soft Front Panel.
Example	Query :SYST:COMM:INST?

3.5.6.2 :SYSTem:COMMunicate:HISLip[:NUMBer]?

Command	:SYST:COMM:HISL?
Long	:SYSTem:COMMunicate:HISLip?
Parameters	None
Parameter Suffix	None
Description	This query returns the HiSLIP number used by the Soft Front Panel.
Example	Query :SYST:COMM:HISL?

3.5.6.3 :SYSTem:COMMunicate:SOCKet[:PORT]?

Command	:SYST:COMM:SOCK?
Long	:SYSTem:COMMunicate:SOCKet?
Parameters	None
Parameter Suffix	None
Description	This query returns the socket port used by the Soft Front Panel.
Example	Query :SYST:COMM:SOCK?

3.5.6.4 :SYSTem:COMMunicate:TELNet[:PORT]?

Command	:SYST:COMM:TELN?
Long	:SYSTem:COMMunicate:TELNet?
Parameters	None
Parameter Suffix	None
Description	This query returns the telnet port used by the Soft Front Panel.
Example	Query :SYST:COMM:TELN?

3.5.6.5 :SYSTem:COMMunicate:TCPIP:CONTRol?

Command	:SYST:COMM:TCP:CONT?
Long	:SYSTem:COMMunicate:TCPIP:CONTRol?
Parameters	None
Parameter Suffix	None
Description	This query returns the port number of the control connection. You can use the control port to send control commands (for example "Device Clear") to the instrument.
Example	Query :SYST:COMM:TCP:CONT?

3.6 Common Command List

3.6.1 *IDN?

Read the instrument's identification string which contains four fields separated by commas. The first field is the manufacturer's name, the second field is the model number, the third field is the serial number, and the fourth field is a revision code which contains four numbers separated dots and a fifth number separated by a dash:
Keysight Technologies, M8195A,<serial number>, x.x.x.x-h
x.x.x.x= Soft Front Panel revision number, e.g. 2.0.0.0
h= Hardware revision number

3.6.2 *CLS

Clear the event register in all register groups. This command also clears the error queue and cancels a *OPC operation. It doesn't clear the enable register.

3.6.3 *ESE

Enable bits in the Standard Event Status Register to be reported in the Status Byte. The selected bits are summarized in the "Standard Event" bit (bit 5) of the Status Byte Register. The *ESE? query returns a value which corresponds to the binary-weighted sum of all bits enabled decimal by the *ESE command. These bits are not cleared by a *CLS command. Value Range: 0-255.

3.6.4 ESR?

Query the Standard Event Status Register. Once a bit is set, it remains set until cleared by a *CLS (clear status) command or queried by this command. A query of this register returns a decimal value which corresponds to the binary-weighted sum of all bits set in the register.

3.6.5 *OPC

Set the "Operation Complete" bit (bit 0) in the Standard Event register after the previous commands have been completed.

3.6.6 *OPC?

Return "1" to the output buffer after the previous commands have been completed. Other commands cannot be executed until this command completes.

3.6.7 *OPT?

Read the installed options. The response consists of any number of fields separated by commas.

3.6.8 *RST

Reset instrument to its factory default state.

3.6.9 *SRE[?]

Enable bits in the Status Byte to generate a Service Request. To enable specific bits, you must write a decimal value which corresponds to the binary-weighted sum of the bits in the register. The selected bits are summarized in the “Master Summary” bit (bit 6) of the Status Byte Register. If any of the selected bits change from “0” to “1”, a Service Request signal is generated. The **SRE?* query returns a decimal value which corresponds to the binary-weighted sum of all bits enabled by the **SRE* command.

3.6.10 *STB?

Query the summary (status byte condition) register in this register group. This command is similar to a Serial Poll but it is processed like any other instrument command. This command returns the same result as a Serial Poll but the “Master Summary” bit (bit 6) is not cleared by the **STB?* command.

3.6.11 *TST?

Execute Self Tests. If self-tests pass, a 0 is returned. A number larger than 0 indicates the number of failed tests.

To get actual messages, use *:TEST:TST?*

3.6.12 *LRN?

Query the instrument and return a binary block of data containing the current settings (learn string). You can then send the string back to the instrument to restore this state later. For proper operation, do not modify the returned string before sending it to the instrument. Use *:SYST:SET* to send the learn string. See [:SYSTem:SET\[?\]](#).

3.6.13 *WAI?

Prevents the instrument from executing any further commands until the current command has finished executing.

3.7 Status Model

Introduction

This section describes the structure of the SCPI status system used by the M8195A. The status system records various conditions and states of the instrument in several register groups as shown on the following pages. Each of the register groups is made up of several low level registers called Condition registers, Event registers, and Enable registers which control the action of specific bits within the register group.

These groups are explained below:

- A condition register continuously monitors the state of the instrument. The bits in the condition register are updated in real time and the bits are not latched or buffered. This is a read-only register and bits are not cleared when you read the register. A query of a condition register returns a decimal value which corresponds to the binary-weighted sum of all bits set in that register.
- An event register latches the various events from changes in the condition register. There is no buffering in this register; while an event bit is set, subsequent events corresponding to that bit are ignored. This is a read only register. Once a bit is set, it remains set until cleared by query command (such as *STAT:QUES:EVEN?*) or a **CLS* (clear status) command. A query of this register returns a decimal value which corresponds to the binary-weighted sum of all bits set in that register.
- An enable register defines which bits in the event register will be reported to the Status Byte register group. You can write to or read from an enable register. A **CLS* (clear status) command will not clear the enable register but it does clear all bits in the event register. A *STAT:PRES* command clears all bits in the enable register. To enable bits in the enable register to be reported to the Status Byte register, you must write a decimal value which corresponds to the binary weighted sum of the corresponding bits.
- Transition Filters are used to detect changes of the state in the condition register and set the corresponding bit in the event register. You can set transition filter bits to detect positive transitions (PTR), negative transitions (NTR) or both. Transition filters are read/write registers. They are not affected by **CLS*.

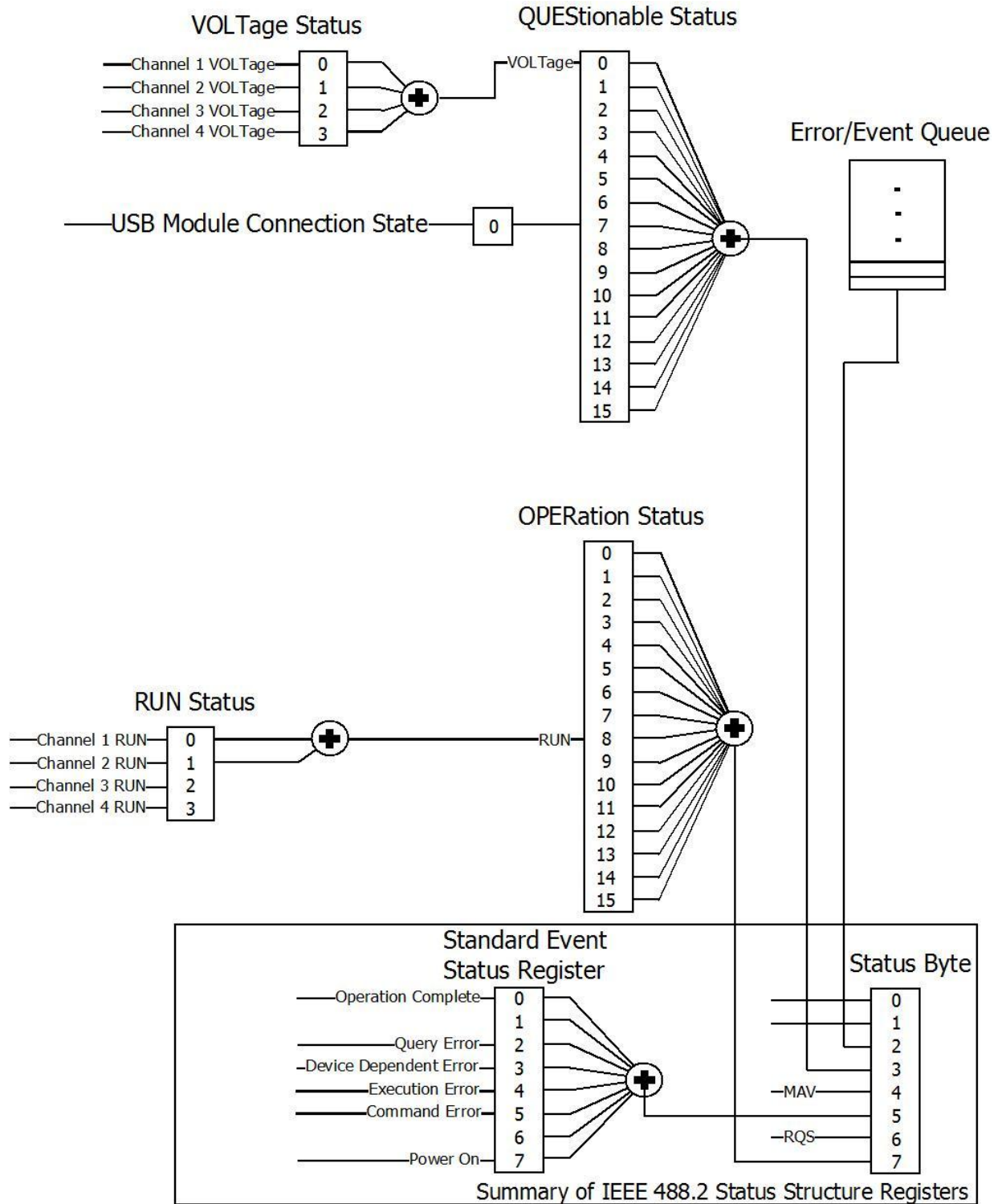

Figure 16: Status register structure

3.7.1 :STATus:PRESet

Clears all status group event registers. Presets the status group enables PTR and NTR registers as follows:

ENABLE = 0x0000, PTR = 0xffff, NTR = 0x0000

3.7.2 Status Byte Register

The Status Byte summary register reports conditions from the other status registers. Data that is waiting in the instrument's output buffer is immediately reported on the "Message Available" bit (bit 4) for example. Clearing an event register from one of the other register groups will clear the corresponding bits in the Status Byte condition register. Reading all messages from the output buffer, including any pending queries, will clear the "Message Available" bit. To set the enable register mask and generate an SRQ (service request), you must write a decimal value to the register using the **SRE* command.

Table 6: Status byte register

Bit Number		Decimal Value	Definition
0	Not used	1	Not Used. Returns "0"
1	Not used	2	Not Used. Returns "0"
2	Error Queue	4	One or more error are stored in the Error Queue
3	Questionable Data	8	One or more bits are set in the Questionable Data Register (bits must be enabled)
4	Message Available	16	Data is available in the instrument's output buffer
5	Standard Event	32	One or more bits are set in the Standard Event Register
6	Master Summary	64	One or more bits are set in the Status Byte Register
7	Operational Data	128	One or more bits set in the Operation Data Register (bits must be enabled)

3.7.3 Questionable Data Register Command Subsystem

The Questionable Data register group provides information about the quality or integrity of the instrument. Any or all of these conditions can be reported to the Questionable Data summary bit through the enable register.

Table 7: Questionable data register

Bit Number		Decimal Value	Definition
0	Voltage warning	1	Output has been switched off (to protect itself)
1	Not used	2	Returns "0"
2	Not used	4	Returns "0"
3	Not used	8	Returns "0"
4	Not used	16	Returns "0"
5	Not used	32	Returns "0"
6	Not used	64	Returns "0"
7	USB disconnected	128	USB module connection state
8	Not used	256	Returns "0"
9	Not used	512	Returns "0"
10	Not used	1024	Returns "0"
11	Not used	2048	Returns "0"
12	Not used	4096	Returns "0"
13	Not used	8192	Returns "0"
14	Not used	16384	Returns "0"
15	Not used	32768	Returns "0"

The following commands access the questionable status group.

3.7.3.1 :STATus:QUEStionable[:EVENT]?

Reads the event register in the questionable status group. It's a read-only register. Once a bit is set, it remains set until cleared by this command or the **CLS* command. A query of the register returns a decimal value which corresponds to the binary-weighted sum of all bits set in the register.

3.7.3.2 :STATus:QUEStionable:CONDition?

Reads the condition register in the questionable status group. It's a read-only register and bits are not cleared when you read the register. A query of the register returns a decimal value which corresponds to the binary-weighted sum of all bits set in the register.

3.7.3.3 :STATus:QUEStionable:ENABle[?]

Sets or queries the enable register in the questionable status group. The selected bits are then reported to the Status Byte. A **CLS* will not clear the enable register but it does clear all bits in the event register. To enable bits in the enable register, you must write a decimal value which corresponds to the binary-weighted sum of the bits you wish to enable in the register.

3.7.3.4 :STATus:QUEStionable:NTRansition[?]

Sets or queries the negative-transition register in the questionable status group. A negative transition filter allows an event to be reported when a condition changes from true to false. Setting both positive/negative filters true allows an event to be reported anytime the condition changes. Clearing both filters disable event reporting. The contents of transition filters are unchanged by **CLS* and **RST*.

3.7.3.5 :STATus:QUEStionable:PTRAnsiOn[?]

Set or queries the positive-transition register in the questionable status group. A positive transition filter allows an event to be reported when a condition changes from false to true. Setting both positive/negative filters true allows an event to be reported anytime the condition changes. Clearing both filters disable event reporting. The contents of transition filters are unchanged by **CLS* and **RST*.

3.7.4 Operation Status Subsystem

The Operation Status register contains conditions which are part of the instrument's normal operation.

Table 8: Operation status register

Bit Number	Decimal Value	Definition
0 Not used	1	Returns "0"
1 Not used	2	Returns "0"
2 Not used	4	Returns "0"
3 Not used	8	Returns "0"
4 Not used	16	Returns "0"
5 Not used	32	Returns "0"
6 Not used	64	Returns "0"
7 Not used	128	Returns "0"
8 Run Status	256	Indicates if system is running
9 Not used	512	Returns "0"
10 Not used	1024	Returns "0"
11 Not used	2048	Returns "0"
12 Not used	4096	Returns "0"
13 Not used	8192	Returns "0"
14 Not used	16384	Returns "0"
15 Not used	32768	Returns "0"

The following commands access the operation status group.

3.7.4.1 :STATus:OPERation[:EVENT]?

Reads the event register in the operation status group. It's a read-only register. Once a bit is set, it remains set until cleared by this command or **CLS* command. A query of the register returns a decimal value which corresponds to the binary-weighted sum of all bits set in the register.

3.7.4.2 :STATus:OPERation:CONDition?

Reads the condition register in the operation status group. It's a read-only register and bits are not cleared when you read the register. A query of the register returns a decimal value which corresponds to the binary-weighted sum of all bits set in the register.

3.7.4.3 :STATus:OPERation:ENABLE[?]

Sets or queries the enable register in the operation status group. The selected bits are then reported to the Status Byte. A **CLS* will not clear the enable register but it does clear all bits in the event register. To enable bits in the enable register, you must write a decimal value which corresponds to the binary-weighted sum of the bits you wish to enable in the register.

3.7.4.4 :STATus:OPERation:NTRansition[?]

Sets or queries the negative-transition register in the operation status group. A negative transition filter allows an event to be reported when a condition changes from true to false. Setting both positive/negative filters true allows an event to be reported anytime the condition changes. Clearing both filters disable event reporting. The contents of transition filters are unchanged by **CLS* and **RST*.

3.7.4.5 :STATus:OPERation:PTRansition[?]

Set or queries the positive-transition register in the operation status group. A positive transition filter allows an event to be reported when a condition changes from false to true. Setting both positive/negative filters true allows an event to be reported anytime the condition changes. Clearing both filters disable event reporting. The contents of transition filters are unchanged by **CLS* and **RST*.

3.7.5 Voltage Status Subsystem

The Voltage Status register contains the voltage conditions of the individual channels.

The following SCPI commands and queries are supported:

```
:STATus:QUEStionable:VOLTagE[:EVENT]?
:STATus:QUEStionable:VOLTagE:CONDition?
:STATus:QUEStionable:VOLTagE:ENABle[?]
:STATus:QUEStionable:VOLTagE:NTRansition[?]
:STATus:QUEStionable:VOLTagE:PTRansition[?]
```

Table 9: Voltage status register

Bit Number	Decimal Value	Definition
0	1	Output 1 has been switched off (to protect itself)
1	2	Output 2 has been switched off (to protect itself)
2	4	Output 3 has been switched off (to protect itself)
3	8	Output 4 has been switched off (to protect itself)

3.7.6 Connection Status Subsystem

The Connection Status register contains the state of the USB connection to the M8195A module.

The following SCPI commands and queries are supported:

:STATus:QUEStionable:CONNection[:EVENt]?

:STATus:QUEStionable:CONNection:CONDection?

:STATus:QUEStionable:CONNection:ENABle[?]

:STATus:QUEStionable:CONNection:NTRansition[?]

:STATus:QUEStionable:CONNection:PTRansition[?]

Table 10: Connection status register

Bit Number	Decimal Value	Definition
0	USB disconnected	1
		USB module connection state

3.7.7 Run Status Subsystem

The Run Status register contains the run status conditions of the individual channels. The following SCPI commands and queries are supported:

```
:STATus:OPERation:RUN[:EVENT]?
:STATus:OPERation:RUN:CONDition?
:STATus:OPERation:RUN:ENABle[?]
:STATus:OPERation:RUN:NTRansition[?]
:STATus:OPERation:RUN:PTRansition[?]
```

Table 11: Run status register

Bit Number		Decimal Value	Definition
0	Run Status	1	Indicates if channel 1 is running
1	Run Status	2	Indicates if channel 2 is running
2	Run Status	4	Indicates if channel 3 is running
3	Run Status	8	Indicates if channel 4 is running

3.8 :ARM/TRIGger Subsystem

3.8.1 :ABORt[1|2|3|4]

Command	:ABOR[1 2 3 4]
Long	:ABORt[1 2 3 4]
Parameters	None
Parameter Suffix	None
Description	Stop signal generation on all channels. The channel suffix is ignored.
Example	Command :ABOR1

3.8.2 :INITiate:IMMediate[1|2|3|4]

Command	:INIT:IMM[1 2 3 4]
Long	:INITiate:IMMediate[1 2 3 4]
Parameters	None
Parameter Suffix	None
Description	Start signal generation on all channels. The channel suffix is ignored
Example	Command :INIT:IMM

3.9 :INSTrument Subsystem

3.9.1 :INSTrument:SLOT[:NUMBer]?

Command	:INST:SLOT?
Long	:INSTrument:SLOT?
Parameters	None

Parameter Suffix	None
Description	Query the instrument's slot number in its AXIe frame.
Example	Query :INST:SLOT?

3.9.2 :INSTrument:IDENtify [<seconds>]

Command	:INST:IDEN
Long	:INSTrument:IDENtify
Parameters	<seconds>
Parameter Suffix	None
Description	Identify the instrument by flashing the green "Access" LED on the front panel for a certain time. <seconds> optional length of the flashing interval, default is 10 seconds.

Example	Command :INST:IDEN 5
----------------	-------------------------

3.9.3 :INSTrument:IDENTify:STOP

Command	:INST:IDEN:STOP
Long	:INSTrument:IDENTify:STOP
Parameters	None
Parameter Suffix	None
Description	Stop the flashing of the green “Access” LED before the flashing interval has elapsed.
Example	Command :INST:IDEN:STOP

3.9.4 :INSTrument:DACMode[?] [DUALchannel|FOURchannel]

Command	:INST:DACM[?]
Long	:INSTrument:DACMode[?]
Parameters	DUALchannel FOURchannel <ul style="list-style-type: none"> • DUALchannel – Channels 1 and 4 can generate a signal, channels 2 and 3 are unused • FOURchannel – Channel 1, 2, 3 and 4 can generate a signal
Parameter Suffix	None
Description	Use this command or query to set or get the operation mode of the DAC.
Example	Command :INST:DACM DUAL

3.10 :MMEMory Subsystem

NOTE

MMEM commands requiring <directory_name> assume the current directory if a relative path or no path is provided. If an absolute path is provided, then it is ignored.

3.10.1 :MMEemory:CATalog? [<directory_name>]

Command	:MMEEM:CAT?
Long	:MMEemory:CATalog?
Parameters	None
Parameter Suffix	None
Description	<p>Query disk usage information (drive capacity, free space available) and obtain a list of files and directories in a specified directory in the following format: <numeric_value>,<numeric_value>,<file_entry>}</p> <p>This command returns two numeric parameters and as many strings as there are files and directories. The first parameter indicates the total amount of storage currently used in bytes. The second parameter indicates the total amount of storage available, also in bytes. The <file_entry> is a string. Each <file_entry> indicates the name, type, and size of one file in the directory list: <file_name>,<file_type>,<file_size></p> <p>As the Windows file system has an extension that indicates file type, <file_type> is always empty. <file_size> provides the size of the file in bytes. In case of directories, <file_entry> is surrounded by square brackets and both <file_type> and <file_size> are empty.</p>
Example	<p>Query</p> <pre>:MMEEM:CAT?</pre>

3.10.2 :MMEemory:CDIRectory [<directory_name>]

Command	:MMEEM:CDIR
Long	:MMEemory:CDIRectory
Parameters	None
Parameter Suffix	None
Description	<p>Changes the default directory for a mass memory file system. The <directory_name> parameter is a string. If no parameter is specified, the directory is set to the <i>*RST</i> value. At <i>*RST</i>, this value is set to the default user data storage area, that is defined as System.Environment.SpecialFolder.Personal e.g. C:\Users\Name\Documents</p> <p><i>MMEemory:CDIRectory?</i> — Query returns full path of the default directory.</p>
Example	<p>Command</p> <pre>:MMEEM:CDIR "C:\Users\Name\Documents"</pre> <p>Query</p> <pre>:MMEEM:CDIR?</pre>

3.10.3 :MMEMory:COPY <string>,<string>[,<string>,<string>]

Command	:MMEM:COPY
Long	:MMEMory:COPY
Parameters	<string>,<string>
Parameter Suffix	None
Description	<p>Copies an existing file to a new file or an existing directory to a new directory. Two forms of parameters are allowed. The first form has two parameters. In this form, the first parameter specifies the source, and the second parameter specifies the destination.</p> <p>The second form has four parameters. In this form, the first and third parameters specify the file names. The second and fourth parameters specify the directories. The first pair of parameters specifies the source. The second pair specifies the destination. An error is generated if the source doesn't exist or the destination file already exists.</p>
Example	<p>Command</p> <pre>:MMEM:COPY "C:\data.txt", "C:\data_new.txt"</pre>

3.10.4 :MMEMory:DELeTe <file_name>[,<directory_name>]

Command	:MMEM:DEL
Long	:MMEMory:DELeTe
Parameters	<file_name>
Parameter Suffix	None
Description	Removes a file from the specified directory. The <file_name> parameter specifies the file to be removed.
Example	Command :MMEM:DEL "C:\data.txt"

3.10.5 :MMEMory:DATA <file_name>, <data>

Command	:MMEM:DATA
Long	:MMEMory:DATA
Parameters	<file_name>, <data>
Parameter Suffix	None
Description	The command form is <i>MMEMory:DATA <file_name>, <data></i> . It loads <data> into the file <file_name>. <data> is in 488.2 block format. <file_name> is string data.

Example	Command :MMEM:DATA "C:\data.txt", #14test
----------------	--

3.10.6 :MMEMory:DATA? <file_name>

Command	:MMEM:DATA?
Long	:MMEMory:DATA?
Parameters	<file_name>
Parameter Suffix	None
Description	The query form is <i>MMEMory:DATA? <file_name></i> with the response being the associated <data> in block format.
Example	Query :MMEM:DATA? "C:\data.txt"

3.10.7 :MMEMory:MDIRectory <directory_name>

Command	:MMEM:MDIR
Long	:MMEMory:MDIRectory
Parameters	<directory_name>
Parameter Suffix	None
Description	Creates a new directory. The <directory_name> parameter specifies the name to be created.
Example	Command :MMEM:MDIR "C:\data_dir"

3.10.8 :MMEMory:MOVE <string>,<string>[,<string>,<string>]

Command	:MMEM:MOVE
Long	:MMEMory:MOVE
Parameters	<string>,<string>
Parameter Suffix	None
Description	Moves an existing file to a new file or an existing directory to a new directory. Two forms of parameters are allowed. The first form has two parameters. In this form, the first parameter specifies the source, and the second parameter specifies the destination. The second form has four parameters. In this form, the first and third parameters specify the file names. The second and fourth parameters specify the directories. The first pair of parameters specifies the source. The second pair specifies the destination. An error is generated if the source doesn't exist or the destination file already exists.

Example

Command

```
:MMEM:MOVE "C:\data_dir","C:\newdata_dir"
```

3.10.9 :MMEMory:RDIRectory <directory_name>

Command	:MMEM:RDIR
Long	:MMEMory:RDIRectory
Parameters	<directory_name >
Parameter Suffix	None
Description	Removes a directory. The <directory_name> parameter specifies the directory name to be removed. All files and directories under the specified directory are also removed.
Example	Command :MMEM:RDIR "C:\newdata_dir"

3.10.10 :MMEMory:LOAD:CState <file_name>

Command	:MMEM:LOAD:CST
Long	:MMEMory:LOAD:CState
Parameters	<file_name >
Parameter Suffix	None
Description	Current state of instrument is loaded from a file.
Example	Command :MMEM:LOAD:CST "C:\data.txt"

3.10.11 :MMEMory:STORe:CState <file_name>

Command	:MMEM:STOR:CST
Long	:MMEMory:STORe:CState
Parameters	<file_name >
Parameter Suffix	None
Description	Current state of instrument is stored to a file.
Example	Command :MMEM:STOR:CST "C:\data.txt"

3.11 :OUTPut Subsystem

3.11.1 :OUTPut[1|2|3|4][:STATe][?] OFF|ON|0|1

Command	:OUTP[?]
Long	:OUTPut[?]
Parameters	OFF ON 0 1
Parameter Suffix	None
Description	Switch the amplifier of the output path for a channel on or off.
Example	Command :OUTP ON
	Query :OUTP?

3.12 Sampling Frequency Commands

3.12.1 [:SOURce]:FREQuency:RASTer[?] <frequency>|MINimum|MAXimum

Command	:FREQ:RAST[?]
Long	:FREQuency:RASTer[?]
Parameters	<frequency> MINimum MAXimum
Parameter Suffix	None
Description	Set or query the sample frequency of the output DAC.
Example	Command :FREQ:RAST MIN
	Query :FREQ:RAST?

3.13 :VOLTage Subsystem

Set the output voltages for a channel.

3.13.1 [:SOURce]:VOLTage[1|2|3|4][:LEVel][:IMMediate][:AMPLitude][?] <level>

Command	:VOLT[?]
Long	:VOLTage[?]
Parameters	<level>
Parameter Suffix	None
Description	Set or query the output amplitude.
Example	Command :VOLT 0.685
	Query :VOLT?

3.13.2 [:SOURce]:VOLTage[1|2|3|4][:LEVel][:IMMediate]:OFFSet[?] <level>

Command	:VOLT:OFFS[?]
Long	:VOLTage:OFFSet[?]
Parameters	<level>
Parameter Suffix	None
Description	Set or query the output offset.
Example	Command :VOLT:OFFS 0.02
	Query :VOLT:OFFS?

3.13.3 [:SOURce]:VOLTage[1|2|3|4][:LEVel][:IMMediate]:HIGH[?] <level>

Command	:VOLT:HIGH[?]
Long	:VOLTage:HIGH[?]
Parameters	<level>
Parameter Suffix	None
Description	Set or query the output high level.
Example	Command :VOLT:HIGH 3e-1
	Query :VOLT:HIGH?

3.13.4 [:SOURce]:VOLTage[1|2|3|4][:LEVel][:IMMediate]:LOW[?] <level>

Command	:VOLT:LOW[?]
Long	:VOLTage:LOW[?]
Parameters	<level>
Parameter Suffix	None
Description	Set or query the output low level.
Example	Command :VOLT:LOW -0.3
	Query :VOLT:LOW?

3.14 Frequency and Phase Response Data Access

3.14.1 [:SOURce]: CHARacterist[1|2|3|4][:VALue]?

Command	:CHAR?
Long	:CHARacterist?
Parameters	None
Parameter Suffix	None
Description	<p>Query the frequency and phase response data for a channel. The query returns the data for the currently configured AWG sample frequency and output amplitude as a string of comma-separated values.</p> <p>The frequency and phase response includes the sin x/ x roll-off of the currently configured AWG sample frequency. As a result the query delivers different results when performed at e.g. 60GSa/s or 65 GSa/s.</p> <p>To achieve optimum frequency and phase compensation results, the frequency and phase response has been characterized individually per channel and for different output amplitudes. As a result, the query delivers different results when performed at e.g. 500 mV or 800 mV.</p> <p>The frequency and phase response refers to the 2.92 mm connector. In case external cables from the 2.92 mm connector to the Device Under Test (DUT) shall be mathematically compensated for as well, the corresponding S-Parameter of that cable must be taken into account separately.</p> <p>Format: The first three values are output frequency 1 in Hz, corresponding relative magnitude in linear scale, corresponding phase in radians. The next three values are output frequency 2, corresponding relative magnitude, corresponding phase, and so on.</p>
Example	<pre> Query :CHAR2? "0,1.01068,0, 1e+008,1.00135,-6.11215e-005, 2e+008,0.993992,-0.000179762, ... 3.19e+010,0.0705237,-3.82659, 3.2e+010,0.0665947,-3.85028" </pre>

3.15 :TRACe Subsystem

Use the :TRACe subsystem to control the arbitrary waveforms and their respective parameters:

- Create waveform segments of arbitrary size with optional initialization.
- Download waveform data into the segments.
- Delete one or all waveform segments from the waveform memory.

3.15.1 Waveform Memory Capacity

The available waveform memory is 256K (262144) samples per channel.

3.15.2 Waveform Length Granularity and Size

The waveform length granularity is 128. The minimum waveform size is 128 samples. The maximum size is equal the complete size of the waveform memory.

3.15.3 Waveform Data Format

In the data formats shown below the fields have the following meanings:
DB7...DB0 - Sample as signed 8-bit value, valid range is -128 to +127.

Samples Format

7	6	5	4	3	2	1	0
DB7	DB6	DB5	DB4	DB3	DB2	DB1	DB0

3.15.4 Arbitrary Waveform Generation

To prepare your module for arbitrary waveform generation follow these steps:

Define a segment using the various forms of the

:TRAC[1|2|3|4]:DEF command.

Fill the segment with sample values using

:TRAC[1|2|3|4]:DATA.

Signal generation starts after calling INIT:IMM.

The waveforms in different channels must have the same lengths. If two or more channels contain differing waveform lengths, an error is returned when trying to start signal generation.

Use the :TRAC[1|2|3|4]:CAT? query to read the length of a waveform loaded into the memory of a channel. Use the :TRAC[1|2|3|4]:DEL:ALL command to delete a waveform from the memory of a channel.

3.15.5 :TRAC[1|2|3|4]:DEF

Command	:TRAC[1 2 3 4]:DEF
Long	:TRACe[1 2 3 4]:DEFine
Parameters	<p><segment_id>,<length>[,<init_value>]</p> <ul style="list-style-type: none"> • <segment_id > – id of the segment, must be 1 • <length> – length of the segment in samples • <init_value> – optional initialization DAC value
Parameter Suffix	None
Description	Use this command to define the size of a waveform memory segment. If <init_value> is specified, all values in the segment are initialized. If not specified, memory is only allocated but not initialized.
Example	<p>Commands</p> <p>Define a segment with id 1 and length 1280 samples on channel 1. Initialize all samples to 0.</p> <pre>TRAC1:DEF 1,1280,0</pre>

3.15.6 :TRAC[1|2|3|4]:DEF:NEW?

Command	:TRAC[1 2 3 4]:DEF:NEW?
Long	:TRACe[1 2 3 4]:DEFine:NEW?
Parameters	<length> [,<init_value>] <ul style="list-style-type: none"> • <length> – length of the segment in samples • <init_value> – optional initialization DAC value
Parameter Suffix	None
Description	Use this query to define the size of a waveform memory segment. If <init_value> is specified, all values in the segment are initialized. If not specified, memory is only allocated but not initialized. If the query was successful, a new <segment_id> will be returned.
Example	Query Define a segment of length 1280 samples on channel 1. Returns the segment id. TRAC1:DEF:NEW? 1280

3.15.7 :TRAC[1|2|3|4]:DEF:WONL

Command	:TRAC[1 2 3 4]:DEF:WONL
Long	:TRACe[1 2 3 4]:DEFine:WONLy
Parameters	<p><segment_id>,<length>[,<init_value>]</p> <ul style="list-style-type: none"> • <segment_id> – id of the segment, must be 1 • <length> – length of the segment in samples • <init_value> – optional initialization DAC value.
Parameter Suffix	None
Description	Use this command to define the size of a waveform memory segment. If <init_value> is specified, all values in the segment are initialized. If not specified, memory is only allocated but not initialized. The segment will be flagged write-only, so it cannot be read back or stored.
Example	<p>Command</p> <p>Define a write-only segment with id 1 and length 1280 samples on channel 1.</p> <pre>:TRAC1:DEF:WONL 1,1280</pre>

3.15.8 :TRAC[1|2|3|4]:DEF:WONL:NEW?

Command	:TRAC[1 2 3 4]:DEF:WONL:NEW?
Long	:TRACe[1 2 3 4]:DEFine:WONLy:NEW?
Parameters	<length>,<init_value> <ul style="list-style-type: none"> • <length> – length of the segment in samples • <init_value> – optional initialization DAC value
Parameter Suffix	None
Description	Use this query to define the size of a waveform memory segment. If <init_value> is specified, all sample values in the segment are initialized. If not specified, memory is only allocated but not initialized. If the query was successful, a new <segment_id> will be returned. The segment will be flagged write-only, so it cannot be read back or stored.
Example	<p>Query</p> <p>Define a write-only segment with length 1280 samples on channel 1.</p> <p>Returns the segment Id.</p> <pre>:TRAC1:DEF:WONL:NEW? 1280</pre>

3.15.9 :TRAC[1|2|3|4]:DATA[?]

Command	:TRAC [1 2 3 4] :DATA [?]
Long	:TRACe [1 2 3 4] :DATA [?]
Parameters	<p><segment_id>,<offset>,<length> <block> <numeric_values></p> <ul style="list-style-type: none"> • <segment_id> – id of the segment, must be 1 • <offset> offset from segment start in samples to allow splitting the transfer in smaller portions • <block> waveform data samples in the data format described above in IEEE binary block format • <numeric_values> waveform data samples in the data format described above in comma separated list format
Parameter Suffix	None
Description	<p>Use this command to load waveform data into the module memory. If <segment_id> is already filled with data, the new values overwrite the current values. If length is exceeded error -223 (too much data) is reported.</p> <p>This SCPI has the following syntax for command/query:</p> <p>Command</p> <pre>:TRACe [1 2 3 4] [:DATA] <segment_id>,<offset>,<block> <numeric_values></pre> <p>Query</p> <pre>:TRACe [1 2 3 4] [:DATA] [?] <segment_id>,<offset>,<length></pre>
Example	<p>Command</p> <p>Load data consisting of 1280 samples as comma-separated list into previously defined segment 1 starting at sample offset 0.</p> <pre>:TRAC1:DATA 1,0,0,1,2,...,1279</pre> <p>Query</p> <pre>:TRAC:DATA? 1,0,1280</pre>

3.15.10 :TRAC[1|2|3|4]:IMP

Command	:TRAC[1 2 3 4]:IMP
Long	:TRACe[1 2 3 4]:IMPoRt
Parameters	<segment_id>, <file_name>, TXT BIN BIN8 IQBIN BIN6030 BIN5110 MAT89600 DSA90000 CSV, IONLY QONLY, ON OFF 1 0, [, ALENgth FI LL[, <init_valueI>[, <init_valueQ>[, <ignore_header_parameters>]]
File Format	<p>Import segment data from a file. Different file formats are supported. An already existing segment can be filled, or a new segment can be created. This can be used to import real waveform data as well as complex I/Q data.</p> <p><segment_id> must be 1</p> <p><file_name> the complete path of the file.</p> <p>TXT BIN BIN8 IQBIN BIN6030 BIN5110 MAT89600 DSA90000 CSV. (See File Type)</p> <p><data_type> IONLY QONLY</p> <p><marker_flag> ON OFF 1 0 (See Marker Flag)</p> <p><padding> ALENgth FILL (See Padding)</p> <p><init_valueI> – optional initialization value. For non-I/Q format this is a DAC value. For I/Q file format this is the I-part of an I/Q sample pair in binary format (int8). Defaults to 0 if not specified.</p> <p><init_valueQ> – optional initialization value, only applicable for I/Q file formats. This is the Q-part of an I/Q sample pair in binary format (int8). Defaults to 0 if not specified.</p> <p><ignore_header_parameters> ON OFF 1 0 (See Ignore Header Parameters)</p>

NOTE

The supported file formats can contain marker bits. These are not available in revision 1.

File Type

TXT

Compatibility: Keysight M8190A, Tek AWG 7000

One file contains waveform samples for one M8195A channel as normalized values (-1.0 .. +1.0) and (optionally marker values) separated by ';' or ',' or '\t'. Not given marker values are just set to 0. Space ' ' and '\t' are ignored. Line end can be \r or \r\n. The waveform samples can be imported to any of the four M8195A channels.

Example (US locale)

0.7,0,1
0.9,1

Example (German locale):

0,7;0;1
0,9;1

NOTE

In German locale it is recommended (but not required) to use ';' or '\t' as separator. But it must then be ensured that the double really has a decimal point (',') or there is some space inserted to ensure correct parsing:

0,7,0,1
0 ,0,1

BIN

Compatibility: Keysight M8190A.

One file contains waveform samples for one channel. The waveform samples can be imported to any of the four M8195A channels. Samples consist of binary int16 values (in little endian byte order).

15	14	13	12	11	10	9	8	7	6	5	4	3	2	1	0
DB13	DB12	DB11	DB10	DB9	DB8	DB7	DB6	DB5	DB4	DB3	DB2	DB1	DB0	SYNM	SMPM

When imported the MSBs DB13 to DB6 are used as 8-bit sample values. All other bits including marker bits SYNM and SMPM are ignored.

BIN8

BIN8 is the most memory efficient file format for the M8195A without digital markers. As a result, the fastest file download can be achieved

One file contains waveform samples for one channel. The waveform samples can be imported to any of the four M8195A channels. Samples consist of binary int8 values:

7	6	5	4	3	2	1	0
DB7	DB6	DB5	DB4	DB3	DB2	DB1	DB0

IQBIN

Compatibility: Keysight M8195A.

One file contains waveform samples for two M8190A channels plus optionally digital marker information.

Channel mapping

I is mapped to channel 1

Q mapped to channel 2

Sample Marker 1 is ignored

Sample Marker 2 is ignored

BIN6030

Compatibility: Keysight N6030

Binary int16 values (in little endian byte order). The Keysight N6030 has 15 bits and uses the most significant digits, ignoring the LSB. While importing, the 8 LSBs are used as sample values, all other bits are ignored.

15	14	13	12	11	10	9	8	7	6	5	4	3	2	1	0
DB13	DB12	DB11	DB10	DB9	DB8	DB7	DB6	DB5	DB4	DB3	DB2	DB1	DB0	X	X

BIN5110

Compatibility: Keysight 5110A

Binary int16 I/Q sample pairs (in little endian byte order). May contain full 16 bit DAC values without the marker bits or 14 bit value plus two markers.

When importing 16 bit values without markers the marker flag should be set to 'OFF' so that 8 LSB are ignored.

For option -R14 there are two possibilities how to map I and Q to the M8195A channels:

- 1 I mapped to channel 1. Q mapped to channel 2
- 2 I mapped to channel 3. Q mapped to channel 4

When importing 14 bit value with markers, the mapping is the following:

- 1 I mapped to channel 1.
- 2 Q mapped to channel 2.
- 3 Marker SMPM ignored.

Marker SYNM ignored.

15	14	13	12	11	10	9	8	7	6	5	4	3	2	1	0
I13	I12	I11	I10	I9	I8	I7	I6	I5	I4	I3	I2	I1	I0	X	SMPM
Q13	Q12	Q11	Q10	Q9	Q8	Q7	Q6	Q5	Q4	Q3	Q2	Q1	Q0	X	SYNM

MAT89600

Compatibility: Keysight 89600 VSA

One file contains waveform samples for one or two or three or four M8195A channels. It is a 89600 VSA recording file in MATLAB binary format (.mat) containing floating point values (without markers). Only MATLAB level 4.0 and 5.0 files are supported.

MATLAB binary files with one, two, three or four columns are supported. If the MATLAB file consists of one column, the data can be imported to channel 1 or channel 2 or channel 3 or channel 4.

Number of columns in MATLAB file for real values	Import and download to M8195A
1	Ch 1 or Ch 2 or Ch 3 or Ch4
2	Ch 1 and Ch 2
3	Ch 1 and Ch 2 and Ch 3
4	Ch 1 and Ch 2 and Ch 3 and Ch4

Note: Unused columns are ignored. Example, in case a four columns file is imported to 2-channel M8195A, columns three and four are ignored.

Both real and complex I/Q data formats are supported. For I/Q format the values are stored as array of complex numbers with the real part corresponding to I value and the imaginary part corresponding to Q value. The header variable 'XDelta' (1/XDelta) is used to set the currently selected sample frequency.

For option -R14 there are two possibilities how to map I and Q to the M8195A channels

1. I mapped to channel 1. Q mapped to channel 2
2. I mapped to channel 3. Q mapped to channel 4

DSA90000

Compatibility: Keysight DSA90000 Oscilloscope

One file contains waveform samples for one M8195A channel. The waveform samples can be imported to any of the four M8195A channels.

DSA90000 waveform file in binary format (.bin) containing header and floating point data (without markers). Only waveform type 'Normal' is supported. If the file contains more than one waveform only the first waveform will be imported.

CSV

Compatibility: M8190A

One file contains waveform samples for one or two or three or four M8195A channels.

Normalized values (-1.0 .. +1.0) and markers in comma delimited format. Without header information, the columns are pre-defined in the following way:

- 1 column: waveform data for channel 1
- 2 columns: waveform data for channel 1 & 2
- 3 columns: waveform data for channel 1 & 2 & 3
- 4 columns: waveform data for channel 1 & 2 & 3 & 4

Examples:

1 channel (without markers):

0.7

0.9

...

2 channel (without markers):

0.7,0.7

0.9,1.0

...

3 channels (without markers):

0.7,0,65,0.36

0.8,0,66,0.35

0.9,0,67,0.34

...

4 channels (without markers):

0.7,0,65,0.36,-0.1

0.8,0,66,0.35;-0.2

0.9,0,67,0.34;-0.33

...

The CSV format may contain optional header information as follows:

Parameter Header

The parameter header contains optional header parameters as name and value pairs separated by '='. Each parameter should be specified in a single line. This header is optional. There are following header parameters:

SampleRate

The sample rate.

SetConfig

Flag to indicate if the header parameters need to be set. This can be set to either 'true' or 'false'. If this flag is 'false' header parameters will not be set. If this flag is omitted header parameters are set.

Data Header

The data header contains the names of the data columns separated by ','. The waveform data are specified after the data header. This header is optional. If this header is not specified the data need to be defined similar to CSV files without the header (see above). The data columns are as follows:

Y1

Waveform data for channel 1.

Y2

Waveform data for channel 2.

Y3

Waveform data for channel 3.

Y4

Waveform data for channel 4.

SampleMarker1

Sample Marker for channel 1.

SampleMarker2

Sample Marker for channel 2.

Notes: If any of the marker columns (SampleMarker1 or Sample Marker2) is present for a channel the data header must contain the waveform data column (Y1 or Y2). It is possible to have only the data columns (Y1 , Y2, Y3, Y4 or any combination) without the marker columns though.

Examples:

SampleRate = 7.2 GHz

Y1, Y2, SampleMarker1, SampleMarker2

0.7,0.7,0,0

0.9,1.0,0,1

0.3,-0.3,1,1

...

Y1, SampleMarker1

0.7,0

0.9,1

0.3,0

...

Y1, SampleMarker1, SampleMarker2

0.7,0,0

0.9,0,1

0.3,1,1

...

Y1, Y2, Y4

0.7,0,65,0.36

0.8,0,66,0.35

0.9,0,67,0.34

...

Marker Flag

This flag is used to specify if the marker data need to be downloaded or not. If this flag is 'OFF' marker data will not be downloaded. Default value is 'ON'. This flag is applicable to BIN5110 format only . If BIN5110 format consists of full 16 bit DAC values (without markers) this flag should be set to 'OFF' so that 2 LSB's are ignored.

Padding	<p>ALENgth: Automatic LENgth : <segment_id> may or may not exist. After execution <segment_id> has exactly the length of the pattern in file or a multiple of this length to fulfill granularity and minimum segment length requirements. Formula: length = granularity * max(5 , # samples in file). This behavior is default if <padding> is omitted.</p> <p>FILL: <segment_id> must exist. If pattern in file is larger than the defined segment length, just ignore excessive samples. If pattern in file is smaller than defined segment length, fill remaining samples with <init_value>. <init_value> defaults to 0 if it is not specified.</p>
Ignore Header Parameters Flag	<p>This flag is used to specify if the header parameters need to be set. If this flag is 'ON' header parameters will not be set. This flag is optional and the default value is 'OFF' i.e. by default the header parameters are set . This flag is applicable to formats (CSV, LICensed and MAT89600) that contain header parameters.</p>
Example	<p>Command</p> <pre data-bbox="532 646 1226 728">:TRAC1:IMP 1, "C:\Program Files (x86)\Keysight\M8195\Examples\WaveformDataFiles\ Sin10MHzAt64GHz.bin", BIN, IONLY, ON, ALEN</pre>

3.15.11 :TRAC[1|2|3|4]:DEL

Command	:TRAC[1 2 3 4]:DEL
Long	:TRACe[1 2 3 4]:DELeTe
Parameters	<segment_id>- id of the segment, must be 1
Parameter Suffix	None
Description	Delete a segment. The command can only be used in program mode.
Example	Command :TRAC:DEL 1

3.15.12 :TRAC[1|2|3|4]:DEL:ALL

Command	:TRAC[1 2 3 4]:DEL:ALL
Long	:TRACe[1 2 3 4]:DELeTe:ALL
Parameters	None
Parameter Suffix	None
Description	Delete all segments. The command can only be used in program mode.
Example	Command :TRAC:DEL:ALL

3.15.13 :TRAC[1|2|3|4]:CAT?

Command	:TRAC[1 2 3 4]:CAT?
Long	:TRACe[1 2 3 4]:CATalog?
Parameters	None
Parameter Suffix	None
Description	The query returns a comma-separated list of segment-ids that are defined and the length of each segment. So first number is a segment id, next length ... If no segment is defined, "0, 0" is returned.
Example	Query :TRAC1:CAT?

3.15.14 :TRAC[1|2|3|4]:FREE?

Command	:TRAC[1 2 3 4]:FREE?
Long	:TRACe[1 2 3 4]:FREE?
Parameters	None
Parameter Suffix	None
Description	The query returns the amount of memory space available for waveform data in the following form: <bytes available>, <bytes in use>, < contiguous bytes available>.
Example	Query :TRAC:FREE?

3.15.15 :TRAC[1|2|3|4]:NAME[?]

Command	:TRAC[1 2 3 4]:NAME[?]
Long	:TRACe[1 2 3 4]:NAME[?]
Parameters	<segment_id>,<name>
Parameter Suffix	None
Description	<p>This command associates a name to a segment. The query gets the name for a segment.</p> <p><segment_id> – must be 1</p> <p><name> – string of at most 32 characters</p>
Example	<p>Command</p> <pre>:TRAC:NAME 1, "ADY"</pre> <p>Query</p> <pre>:TRAC:NAME? 1</pre>

3.15.16 :TRAC[1|2|3|4]:COMM[?]

Command	:TRAC[1 2 3 4]:COMM[?]
Long	:TRACe[1 2 3 4]:COMMe[nT][?]
Parameters	<segment_id>,<comment>
Parameter Suffix	None
Description	<p>This command associates a comment to a segment. The query gets the comment for a segment.</p> <p><segment_id> – must be 1</p> <p><comment> – string of at most 256 characters</p>
Example	<p>Command</p> <pre>:TRAC:COMM 1, "Comment"</pre> <p>Query</p> <pre>:TRAC:COMM? 1</pre>

3.16 :TEST Subsystem

3.16.1 :TEST:PON?

Command	:TEST:PON?
Long	:TEST:PON?
Parameters	None
Parameter Suffix	None
Description	Return the results of the power on self-tests.
Example	Query :TEST:PON?

3.16.2 :TEST:TST?

Command	:TEST:TST?
Long	:TEST:TST?
Parameters	None
Parameter Suffix	None
Description	Same as <i>*TST?</i> , but the actual test messages are returned.
Example	Query :TEST:TST?

NOTE

Currently same as :TEST:PON?

4 Examples

- 4.1 [Introduction](#) / 115
- 4.2 [Remote Programming Examples](#) / 115
- 4.3 [Example Files for Import](#) / 115
- 4.4 [Example Correction Files](#) / 115
- 4.5 [Example Custom Modulation Files](#) / 116

4.1 Introduction

In a standard installation the examples can be found in the folder “C:\Program Files (x86)\Keysight\M8195\Examples”.

4.2 Remote Programming Examples

The MATLAB IQtools are described in file “README.docx” in subfolder “MATLAB\iqtools”. The C++, C# and VB programs are provided as Visual Studio 2008 solutions. But they can be easily converted to more recent Visual Studio versions. They show how to connect to the AWG, write a sine wave into the memory and start signal generation. They use the VISA or VISA-COM libraries.

4.3 Example Files for Import

The subfolder “WaveformDataFiles” contains examples for all supported import file formats. To import them use either the SFP Import Waveform panel or the SCPI command TRAC[1|2|3|4]:IMP.

4.4 Example Correction Files

The subfolder “CorrectionFiles” contains examples to be used in the SFP Multi-Tone and Complex Modulation panels.

4.5 Example Custom Modulation Files

The subfolder “CustomModulationFiles” contains examples to be used in the SFP Complex Modulation panel.

5 Appendix

5.1 Resampling Algorithms for Waveform Import / 117

5.1 Resampling Algorithms for Waveform Import

5.1.1 Resampling Requirements

Resampling is typically associated to a series of processes applied to a waveform sampled at a given sampling frequency to generate a new waveform with a different sampling rate while preserving all the original information contained in the signal within the Nyquist bandwidth corresponding to the output sampling rate. Processes involved in resampling may vary depending on the output to input sampling rate ratio (or resampling factor) and the integer nature of the ratio itself. Resampling calculations, when applied to arbitrary waveform generation, must meet additional constraints such as available record length boundaries, record length granularity requirements, or acceptable sampling rate range.

Typically the characteristics of the input waveform (sampling rate, record length) are externally defined (i.e. by the horizontal settings of an oscilloscope used to capture the waveform). Users may be interested in resampling the signal to adapt the input waveform to the AWG requirements or the user desires. In some cases it may be necessary to reduce the sampling rate if it has been captured at a higher sampling rate than the one allowed by the AWG or to reduce the record length required to generate it. The opposite is also true as oversampling may help to “smooth” the signal as increasing sampling rate will shift the images created by the DAC to a higher frequency. Finally, resampling may be also necessary to adapt the record length of the input waveform to a legal record length that can be applied to a real AWG (i.e. to meet the record length granularities) without applying truncation or “zero padding” to the input waveform.

5.1.2 Resampling Methodology

Generally speaking, resampling factors do not have to be an integer or a simple fractional ratio. Because of that, traditional methods based in upsampling/filtering/decimation techniques may not be suitable given the amount of calculations resulting from the typical input waveform sizes involved. Instead of this, a more straight forward approach has been chosen. This approach is based in the following principles:

- Only output samples will be calculated so there is not any up-sampling and/or down-sampling operations involved.
- Filtering calculations will be kept to a minimum by using a filter with a fast enough roll-off and sufficient stop band attenuation according to the target AWG dynamic range.
- Interpolation filter and anti-alias filters are exactly the same although the filter parameters will depend on the resampling parameters.
- The implemented algorithm does perform filtering and interpolation simultaneously so the number of calculations is greatly reduced. Additionally, filters are implemented as look-up tables so those are calculated only once during the process.
- Timing parameters are based in double precision floating-point numbers while amplitude related parameters are single precision numbers. Most calculations consist in multiplication/addition operations required by convolution processes and only involve amplitude related variables (input samples and filter coefficients). Single precision numbers will minimize calculation time while offering more than enough dynamic range.

Interpolators and anti-aliasing filters share most characteristics as they are required to be low-pass with good flatness, linear phase, fast roll-off, and high stop-band rejection ratio. Ideal interpolator filters show a “brick-wall” response. However, such filters require a very long “sinc-like” impulse response to obtain good-enough performance. Impulse response length has a direct effect on calculation times resulting of applying the filter. Roll-off characteristics are especially important when applying the filter as the anti-alias filter required for down-sampling. The filter implemented in these algorithms has been designed with the following objectives:

- Pass band flatness better than 0.01 dB
- Stop band attenuation better than 80 dB
- F80dB/F3dB ratio better than 1.15

The final filter consists in a sinc signal with a 41 sample periods length after applying a Blackman-Harris time-domain window.

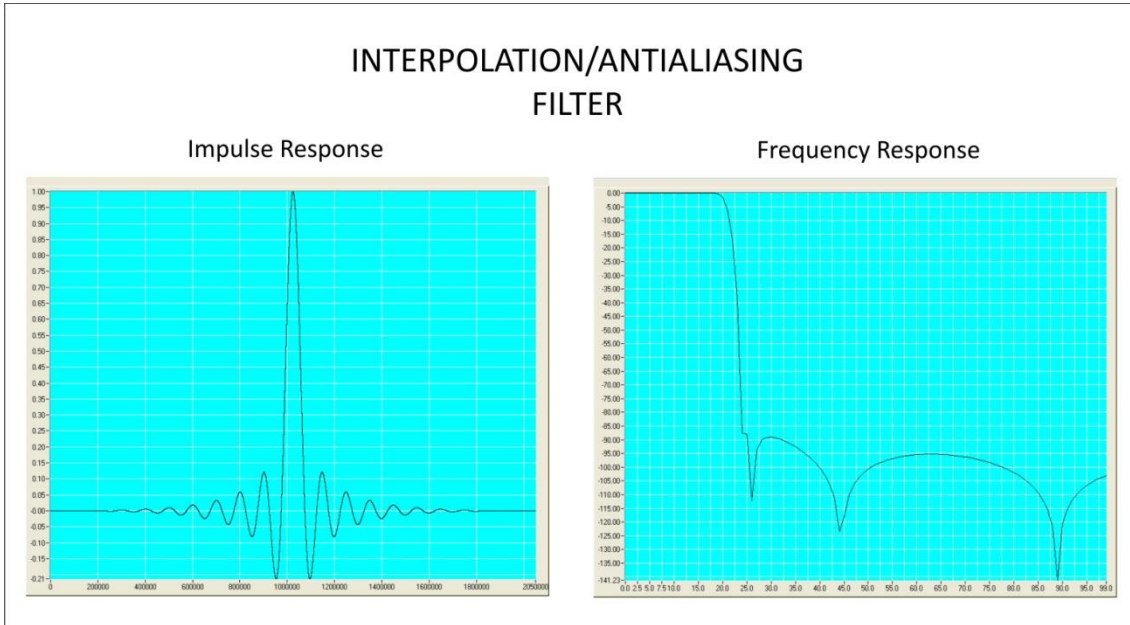

Figure 17: Interpolation/Antialiasing filter

The filter shape remains the same no matter the resampling characteristics. For resampling ratios greater than 1.0, filter will implement an interpolator so nulls in the impulse response must be located at multiples of the sampling period of the input signal. For ratios lower than 1.0 the filter will implement an antialiasing filter. In this case, distance between nulls will have to be longer than the output waveform sampling period so the filter reach the required attenuation (>80dB) at the output signal Nyquist frequency. For the implemented filter this is accomplished by choosing 0.89 ratio between the output sampling period and the distance between consecutive nulls in the filter's impulse response.



This information is subject to change without notice.
© Keysight Technologies 2014
Edition 2.0, October 2014



M8195-91020

www.keysight.com