

Agilent N4968A

**Clock and Data Demultiplexer
44 Gb/s**

User Guide

Notices

© Agilent Technologies, Inc. 2012

No part of this manual may be reproduced in any form or by any means (including electronic storage and retrieval or translation into a foreign language) without prior agreement and written consent from Agilent Technologies, Inc. as governed by United States and international copyright laws.

Manual Part Number

N4968-91021

Edition

Third edition, April 2014

Agilent Technologies, Deutschland GmbH

Herrenberger Str. 130

71034 Böblingen, Germany

For Assistance and Support

<http://www.agilent.com/find/assist>

Limitation of Warranty

The foregoing warranty shall not apply to defects resulting from improper or inadequate maintenance by Buyer, Buyer-supplied software or interfacing, unauthorized modification or misuse, operation outside of the environmental specifications for the product, or improper site preparation or maintenance. No other warranty is expressed or implied. Agilent Technologies specifically disclaims the implied warranties of Merchantability and Fitness for a Particular Purpose.

Warranty

The material contained in this document is provided “as is,” and is subject to being changed, without notice, in future editions. Further, to the maximum extent permitted by applicable law, Agilent disclaims all warranties, either express or implied, with regard to this manual and any information contained herein, including but not limited to the implied warranties of merchantability and fitness for a particular purpose. Agilent shall not be liable for errors or for incidental or consequential damages in connection with the furnishing, use, or performance of this document or of any information contained herein. Should Agilent and the user have a separate written agreement with warranty terms covering the material in this document that conflict with these terms, the warranty terms in the separate agreement shall control.

Technology Licenses

The hardware and/or software described in this document are furnished under a license and may be used or copied only in accordance with the terms of such license.

Restricted Rights Legend

If software is for use in the performance of a U.S. Government prime contract or subcontract, Software is delivered and licensed as “Commercial computer software” as defined in DFAR 252.227-7014 (June 1995), or as a “commercial item” as defined in FAR 2.101(a) or as “Restricted computer software” as defined in FAR 52.227-19 (June 1987) or any equivalent agency regulation or contract clause. Use, duplication or disclosure of Software is subject to Agilent Technologies’ standard commercial license terms, and non-DOD Departments and Agencies of the U.S. Government will receive no greater than Restricted Rights as defined in FAR 52.227-19(c)(1-2) (June 1987). U.S. Government users will receive no greater than Limited Rights as defined in FAR 52.227-14 (June 1987) or DFAR 252.227-7015 (b)(2) (November 1995), as applicable in any technical data.

Safety Notices

CAUTION

A **CAUTION** notice denotes a hazard. It calls attention to an operating procedure, practice, or the like that, if not correctly performed or adhered to, could result in damage to the product or loss of important data. Do not proceed beyond a **CAUTION** notice until the indicated conditions are fully understood and met.

WARNING

A **WARNING** notice denotes a hazard. It calls attention to an operating procedure, practice, or the like that, if not correctly performed or adhered to, could result in personal injury or death. Do not proceed beyond a **WARNING** notice until the indicated conditions are fully understood and met.

NOTE

A **NOTE** provides important or special information.

Safety Summary

General Safety Precautions

The following general safety precautions must be observed during all phases of operation of this instrument. Failure to comply with these precautions or with specific warnings elsewhere in this manual violates safety standards of design, manufacture, and intended use of the instrument.

Agilent Technologies Inc. assumes no liability for the customer's failure to comply with these requirements.

Before operation, review the instrument and manual for safety markings and instructions. You must follow these to ensure safe operation and to maintain the instrument in safe condition.

Initial Inspection

Inspect the shipping container for damage. If there is damage to the container or cushioning, keep them until you have checked the contents of the shipment for completeness and verified the instrument both mechanically and electrically. The Performance Tests give procedures for checking the operation of the instrument. If the contents are incomplete, mechanical damage or defect is apparent, or if an instrument does not pass the operator's checks, notify the nearest Agilent Technologies Sales/Service Office.

WARNING To avoid hazardous electrical shock, do not perform electrical tests when there are signs of shipping damage to any portion of the outer enclosure (covers, panels, etc.).

General

This product is a Safety Class 1 product (provided with a protective earthing ground incorporated in the power cord). The mains plug shall only be inserted in a socket outlet provided with a protective earth contact. Any interruption of the protective conductor, inside or outside of the instrument, will make the instrument dangerous. Intentional interruption is prohibited.

Environment Conditions

This instrument is intended for indoor use in an installation category II, pollution degree 2 environment per IEC 61010 Second Edition and 664 respectively. It is designed to operate within a temperature range of 10 to 40 °C at a maximum relative humidity of 80% for temperatures up to 31 °C, decreasing linearly to 50% relative humidity at 40 °C at an altitude of 2000 meters.

This module can be stored or shipped at temperatures between -40°C and +70°C. Protect the module from temperature extremes that may cause condensation within it.

Before Applying Power

Verify that all safety precautions are taken. The power cable inlet of the instrument serves as a device to disconnect from the mains in case of hazard. The instrument must be positioned so that the operator can easily access the power cable inlet. When the instrument is rack mounted the rack must be provided with an easily accessible mains switch.

Ground the Instrument

Install the instrument so that the ON / OFF switch is readily identifiable and is easily reached by the operator. The ON / OFF switch is the instrument disconnecting device. It disconnects the mains circuits from the mains supply before other parts of the instrument. Or the detachable power cord can be removed from the electrical supply. Alternately, an externally installed switch or circuit breaker which is readily identifiable and is easily reached by the operator may be used as a disconnecting device.

Do Not Operate in an Explosive Atmosphere

Do not operate the instrument in the presence of flammable gases or fumes.

Do Not Remove the Instrument Cover

Operating personnel must not remove instrument covers. Component replacement and internal adjustments must be made only by qualified personnel.

Instruments that appear damaged or defective should be made inoperative and secured against unintended operation until they can be repaired by qualified service personnel.

Symbols on Instruments



The instruction documentation symbol. The product is marked with this symbol when it is necessary for the user to refer to the instruction in the documentation.



C-Tick Conformity Mark of the Australian ACA for EMC compliance.



Indicates that protective earthing ground is incorporated in the power cord.

ICES/NMB-001

This mark indicates compliance with the Canadian EMC regulations.

ISM 1-A

This text denotes the instrument is an Industrial Scientific and Medical Group 1 Class A product.



CE Marking to state compliance within the European Community: This product is in conformity with the relevant European Directives: EMC Directive 2004/108/EC and Low Voltage Directive 2006/95/EC.



This symbol indicates that internal circuits can be damaged by electrostatic discharge (ESD), therefore, avoid applying static discharges to the panel input connectors.



China RoHS regulations include requirements related to packaging, and require compliance to China standard GB18455-2001. This symbol indicates compliance with the China RoHS regulations for paper/fiberboard packaging.



Indicates the time period during which no hazardous or toxic substance elements are expected to leak or deteriorate during normal use. Forty years is the expected useful life of the product.



The Korean Certification (KC) mark is required for products that are subject to legally compulsory certification.

The KC mark includes the marking's identifier code that has up to 26 digits and follows this format: KCC-VWX-YYY-ZZZZZZZZZZZZ.



This symbol indicates that the instrument requires alternating current (AC) input.



This symbol indicates that the power line switch is in the ON position.



This symbol indicates that the power line switch is in the OFF position.

Environmental Information

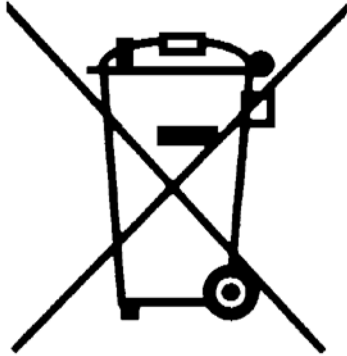

This product complies with the WEEE Directive (2002/96/EC) marketing requirements. The affixed label indicates that you must not discard this electrical/electronic product in domestic household waste.

Product category: With reference to the equipment types in the WEEE Directive Annexure I, this product is classed as a "Monitoring and Control instrumentation" product.

Do not dispose in domestic household waste.

To return unwanted products, contact your local Agilent office, or see

www.agilent.com/environment/product/ for more information.

Contents

1	Getting Started	9
1.1	Unpacking and Installation	9
1.2	Important Notes.....	10
1.3	Performance Recommendations.....	10
2	N4968A Operation Overview.....	11
2.1	Features.....	11
2.2	Front Panel Quick Reference	12
2.3	Rear Panel Quick Reference	13
2.4	Safety and Regulatory.....	14
3	Performance Specifications.....	15
3.1	General	15
3.2	N4968A Clock and Data Demultiplexer Specifications	16
4	Operation	17
4.1	General Information	17
4.1.1	Performance Recommendations.....	18
4.1.2	Connector Care	18
4.2	Block Diagram.....	20
4.2.1	Divide Ratio Switch Settings	21
4.3	Demux-by-4 Example with 40 Gb/s Data Input.....	22
4.4	Demux-by-2 Example with 20 Gb/s Data Input with Full Rate Clock...	23
5	Returning the N4968A to Agilent Technologies.....	25

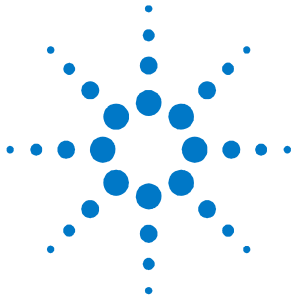

1 Getting Started

1.1 Unpacking and Installation

The N4968A clock and data demultiplexer 44 Gb/s is shipped with all the accessories required for verification and operation.

The shipment includes:

- N4968A clock and data demultiplexer 44 Gb/s
- AC power converter module
- AC power cord
- CD containing the N4968A user guide and N4968A data sheet

WARNING

If this product is not used as specified, the protection provided by the equipment could be impaired. This product must be used in a normal condition (in which all means for protection are intact) only.

CAUTION

Before switching on this instrument, make sure the supply voltage is in the specified range.

CAUTION

This instrument has auto ranging line voltage input. Be sure the supply voltage is within the specified range.

In an ESD-safe environment, carefully remove the N4968A from the packaging. Install on a flat surface with unobstructed air flow to the back panel. Plug the AC power cord into the power converter module and a wall socket, then plug the converter module into the N4968A.

1.2 Important Notes

- Use ESD protection at all times when using the system.
 - Review min/max specifications before applying input signals.
 - Use only high quality RF connectors on the RF ports.
 - Use dust jackets on unused back panel connectors.
 - Situate the instrument away from heat sources.
-

1.3 Performance Recommendations

1. When using differential-mode connections, ensure the cables are phase balanced.
 2. Differential connectors may be used single-ended if the unused input or output is terminated in 50 Ω .
 3. Use high quality cables and connector savers (or adaptors).
 4. Keep cable lengths short and minimize number of cable bends.
 5. Use a 7 to 10 in-lbs torque wrench when attaching connectors.
-

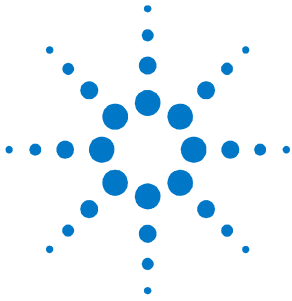

2 N4968A Operation Overview

The Agilent technologies N4968A clock and data demultiplexer 44 Gb/s is a small high-performance 3.5 to 44 Gb/s clock and data demultiplexer, designed to simplify the process of making high-bitrate BER measurements at half- or quarter-rate speeds. The N4968A clock and data demultiplexer 44 Gb/s is capable of operating in demux-by-4 up to 44 Gb/s data rate or in demux-by-2 up to 22 Gb/s data rate with an adjustable sub-rate clock output for triggering BER testers, oscilloscopes, logic analyzers, or other instruments.

The N4968A also has clock frequency dividers. The input clock frequency can be divided down to lower rates to match the de-multiplexed data and used to drive equipment such as external error detectors when making a BER measurement.

2.1 Features

- Clock and data demultiplexer for lower-rate BER measurements
 - 3.5 to 44 Gb/s operation
 - Demux-by-2 or demux-by-4
 - Integrated phase shifter for high-speed clock and data alignment
 - Differential or single-ended input
 - Adjustable sub-rate clock output
-

2.2 Front Panel Quick Reference



Figure 1. N4968A front panel

- CLK 1:** CLK 1 is the clock input and must be a half rate clock for 1:4 demultiplexing or full rate clock for 1:2 demultiplexing. This input is AC coupled.
- CLK 1 Phase Adj:** The phase adjust knob aligns the clock edge to the middle of the opening in the input data eye for error free output from the demultiplexer.
- Data In:** The Data In and Data In/ are differential inputs for the data. These connectors are 1.85 mm female connectors. If the data input is used single ended the input should be connected through a DC block and the unused input should be terminated with a 50 Ω 1.85 mm terminator.
- Demux Data Out:** The demuxed data outputs are routed thru the Demux Data Out1 through Demux Data Out4 connectors. These are 2.92 mm female connectors. They are single ended AC coupled outputs.
-

2.3 Rear Panel Quick Reference



Figure 2. N4968A rear panel

Divided Output Clocks: Divided clock outputs can be divided into ratios to get four output clocks. The four output clocks can be used as four single ended clocks or two pairs of differential clocks. The clock outputs are AC coupled.

A and F connector: The clock input is routed to these connectors.

B and D connectors: The B and D connectors are the inputs to divider number 1.

C and G connectors: The C and G connectors are the outputs of divider number 1.

E connector: The E connector is the input to divider number 2, which in conjunction with divider numbers 3 and 4 is used to provide sub-rate clock outputs for downstream equipment.

CLK 2: The CLK 2 connector is the input to the phase shifter/demux.

Divide ratio switch: The eight switches set the different divide ratios.

NOTE

Refer to configuration diagrams for use of these connections in various applications.

Power switch: The rear panel power switch applies power to the N4968A.

Aux Out: The center conductor of this port is -5 V. Use of this port is not supported.

Label: N4968A serial number.

2.4 Safety and Regulatory

This product has been designed and tested in accordance with accepted industry standards, and has been supplied in a safe condition. The documentation contains information and warnings that must be followed by the user to ensure safe operation and to maintain the product in a safe condition.

WARNING

Do not remove instrument covers. There are no user serviceable parts within. Operation of the instrument in a manner not specified by Agilent Technologies may result in personal injury or loss of life.

WARNING

To prevent electrical shock, disconnect instrument from mains before cleaning. Use a dry cloth or one slightly dampened with water to clean the external case parts. Do not attempt to clean internally.

WARNING

For continued protection against fire hazard, replace fuses, and or circuit breakers only with same type and ratings. The use of other fuses, circuit breakers or materials is prohibited.

CAUTION

The Mains wiring and connectors shall be compatible with the connector used in the premise electrical system. Failure, to ensure adequate earth grounding by not using the correct components may cause product damage, and serious injury.

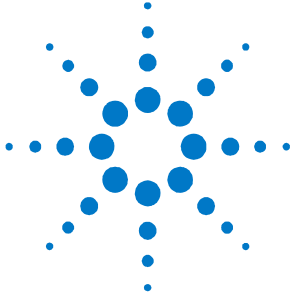

3 Performance Specifications

Specifications describe the instrument's warranted performance. Non-warranted values are stated as typical. All specifications are valid in a range from 10 °C to 40 °C ambient temperature after a 30 minute warm-up phase.

3.1 General

Table 1. General and mechanical parameters of N4968A

Operating Temperature	+10 to +40 °C
Storage Temperature	−40 to +70°C
Power Requirements	42 W External AC Adaptor (included) <ul style="list-style-type: none"> • 100 to 240 VAC, 47 to 63 Hz
Physical Dimensions (W x H x D)	25.4 x 6.35 x 25.4 cm (7 x 2.5 x 10 inches)
Weight	3.2 kg (7 lbs)
EMC	<p>Complies with European EMC Directive 2004/108/EC</p> <ul style="list-style-type: none"> • IEC/EN 61326-1 • CISPR Pub 11 Group 1, class A • AS/NZS CISPR 11 • ICES/NMB-001 <p>This ISM device complies with Canadian ICES-001.</p> <p>Cet appareil ISM est conforme a la norme NMB-001 du Canada.</p>

3.2 N4968A Clock and Data Demultiplexer Specifications

Table 2. N4968A clock and data demultiplexer specifications

Parameter	Specification
Data input	
Data rate	3.5 to 44 Gb/s
Data amplitude	150 to 1000 mV p-p single-ended Maximum DC voltage ± 0.5 V
Interface	Differential. DC coupled, 50 Ω nominal, 1.85 mm female connectors. Can be used single-ended if unused input is terminated with 50 Ω load.
Data output	
Data rate	0.875 to 11 Gb/s
Data amplitude	> 210 mV p-p typical
Interface	Single-ended outputs. AC coupled, 50 Ω nominal, 2.92 mm female connectors.
Clock input	
Type	Half-rate clock for demux-by-4 mode Full-rate clock for demux-by-2 mode
Frequency	1.75 to 22 GHz for demux-by-4 mode ¹ 3.5 to 22 GHz for demux-by-2 mode ²
Clock amplitude	+2 to +10 dBm (0.8 to 2 V p-p)
Interface	Single-ended input. AC coupled, 50 Ω nominal, 2.92 mm female connector.
Divided clock outputs	
Division ratios	1, 2, 4, 8, 16, 32, and 64
Clock amplitude	> -5 dBm (355 mV p-p) typical
Interface	Differential outputs. AC coupled, 50 Ω nominal, SMA mm female connectors. Can be used single-ended if unused input is terminated with 50 Ω load.

¹ Demux-by-4 mode data rate is 3.5 to 44 Gb/s.

² Demux-by-2 mode data rate is 3.5 to 22 Gb/s.

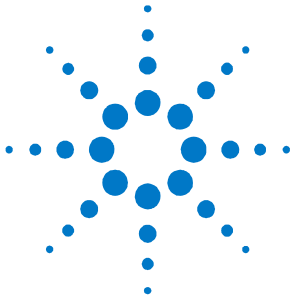

4 Operation

The following section provides more detailed information regarding the use of the N4968A.

4.1 General Information

The N4968A should be used in accordance with the following:

- Read and follow operating instructions; do not exceed min/max specifications.
 - Use ESD protection at all times, but especially when handling RF input/outputs; ground coaxial cable conductor pins before use to remove static buildup.
 - Situate the instrument away from heat sources.
 - Do not allow foreign material into enclosure.
 - Always use provided AC adaptor. Do not power the unit with a different adaptor. Do not modify the power plug or wall outlet to remove the third (ground) pin.
 - Do not drop or shake the instrument; minimize vibration; handle with care.
 - There are no user-serviceable parts within. Return damaged instruments for factory-authorized repair. Refer to instrument warranty for more information.
-

4.1.1 Performance Recommendations

Follow the following recommendations for best performance:

1. When using differential mode connections, ensure the cables are phase balanced. If the electrical length of one cable is a significant fraction of a unit interval longer than the other, the quality of the differential signal will be degraded.
 2. Keep cable lengths short and minimize number of cable bends.
 3. When using a single port of differential output channel for single-ended measurements, the complementary port must be terminated with a 50 Ω termination.
-

4.1.2 Connector Care

The N4968A features high-quality front and rear panel input and output connectors. Connector damage will degrade signal fidelity.

Refer to the N4960-90030 N495xA through N498xA Connector Care Reference Guide at www.agilent.com/find/N4968A.

Agilent Technologies also recommends the following:

- Use a 7 to 10 in-lbs torque wrench when attaching connectors.
- Consider using connector savers to prolong performance and minimize damage.
- Differential connectors may be used single-ended if second end terminated in 50 Ω .

Inspect the connectors for the following:

- Worn or damaged threads
- Scratches to mating surface
- Burrs and loose metal particles
- Dust or foreign material in the space surrounding the center pin
- Ensure that female contacts are straight and aligned

Clean the connectors as described in the following procedure. Cleaning connectors with alcohol shall only be done with the instruments power cord removed, and in a well-ventilated area. Allow all residual alcohol moisture to evaporate, and the fumes to dissipate prior to energizing the instrument.

1. Remove any dust or loose particles using a low-pressure air source.
 2. Moisten a lint-free swab with isopropyl alcohol. Do not saturate the swab.
 3. Minimize the wicking of the alcohol into the connector structure.
 4. Clean the mating plane surfaces and threads.
 5. Allow alcohol to evaporate, and then use a low-pressure air source to blow surfaces clean.
 6. Make sure no particles or residue remains.
 7. Inspect connector for damage.
-

4.2 Block Diagram

The block diagram is shown in Figure 3.

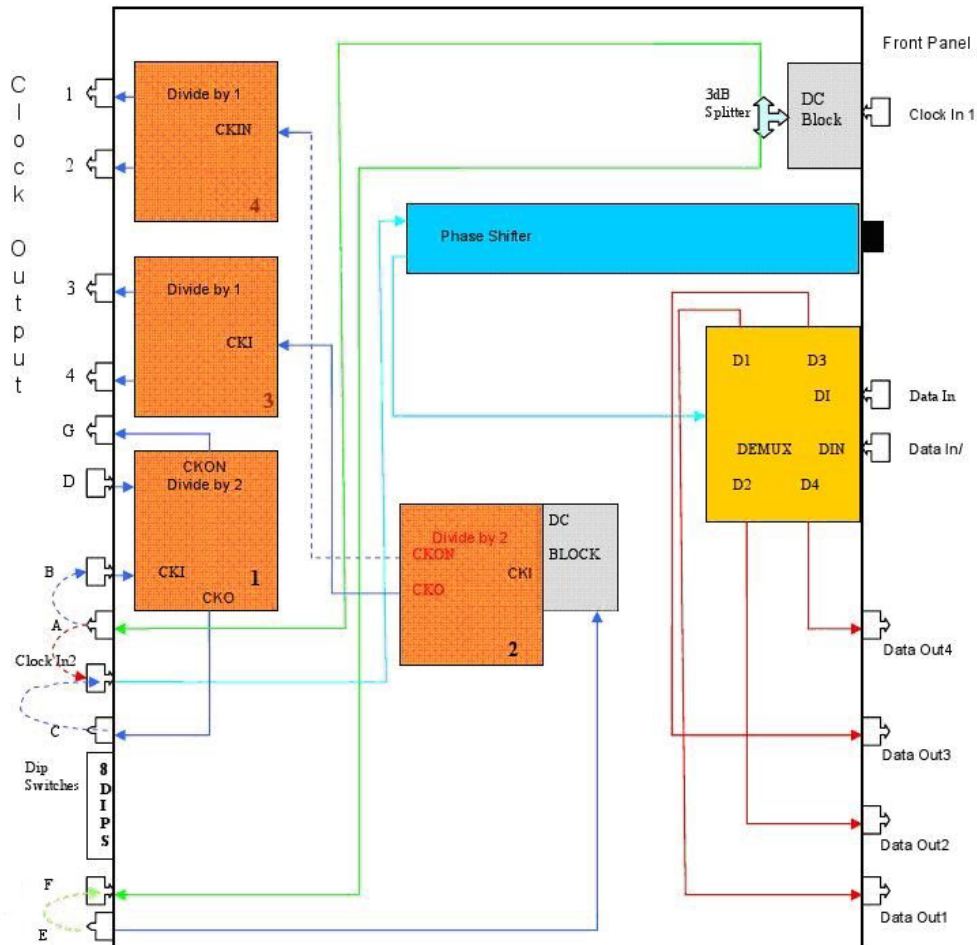

Figure 3. N4968A block diagram

The N4968A Clock and Data Demultiplexer consists of a 1:4 demultiplexer module + 4 clock divider and can be used in either 1:4 demux mode with a half rate clock input, or in 1:2 demux mode (up to 22 Gb/s max data rate) with a full rate clock input.

The clock divider ratios can be set to match the output (de-multiplexed) data rate for sending to external equipment such as a bit error ratio tester, or sampling scope.

Refer to the configuration examples below for setup details in various applications.

4.2.1 Divide Ratio Switch Settings

Figure 4 shows the Dividers switch on the rear panel of the N4968A. Note that Divider 1 and 2 switches are set to 1 and Divider 3 and 4 switches are set to 0 in Figure 4.

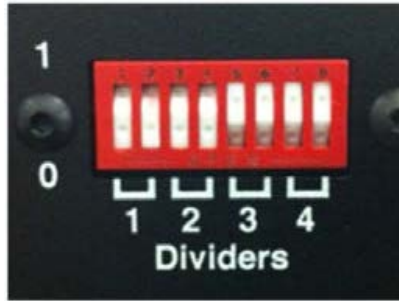

Figure 4. Dividers switch

Table 3. Divider #1

Switch #1	Switch #2	Division Ratio
0	0	1
0	1	1/4
1	0	1/8
1	1	1/2

Table 4. Divider #2

Switch #3	Switch #4	Division Ratio
0	0	1
0	1	1/4
1	0	1/8
1	1	1/2

Table 5. Divider #3

Switch #5	Switch #6	Division Ratio
0	0	1
0	1	1/4
1	0	1/8
1	1	1/2

Table 6. Divider #4

Switch #7	Switch #8	Division Ratio
0	0	1
0	1	1/4
1	0	1/8
1	1	1/2

4.3 Demux-by-4 Example with 40 Gb/s Data Input

1. Configuration:
 - Data input = 40 Gb/s
 - Clock input = 20 GHz
 - Data output = 4 x 10 Gb/s
 - Clock output = 10 GHz
2. Loop A to Clk2 (provides 20 GHz half-rate clock to Demux).
3. Loop E to F.
4. Set Divider 2 to $\frac{1}{2}$.
5. Set Divider 3 and 4 to 1 (provides 10 GHz clock output).

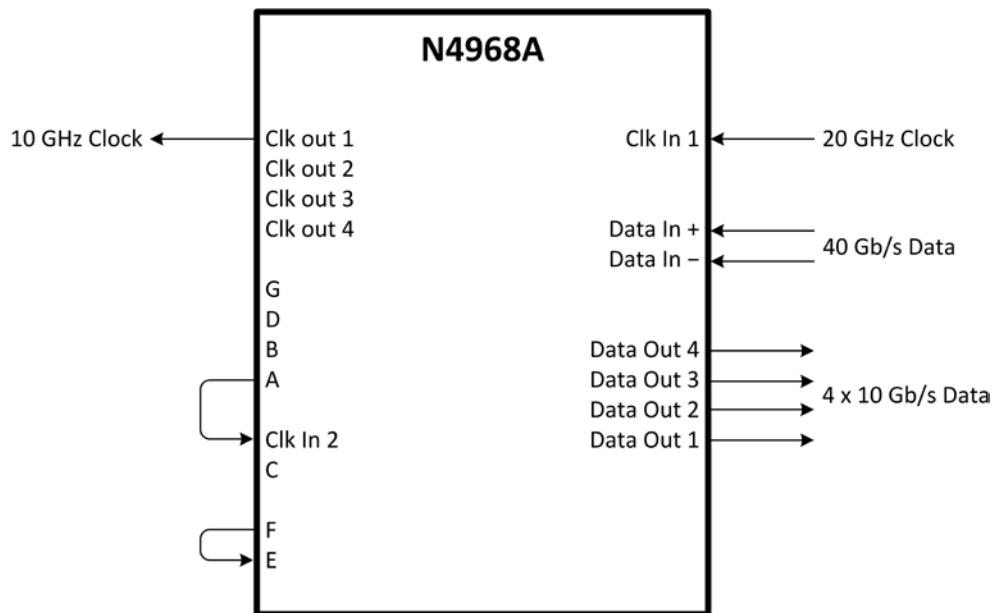

Figure 5. Demux-by-4 example with 40 Gb/s data input

4.4 Demux-by-2 Example with 20 Gb/s Data Input with Full Rate Clock

1. Configuration:
 - Data input = 20 Gb/s
 - Clock input = 20 GHz
 - Data output = 2 x 10 Gb/s
 - Clock output = 10 GHz
2. Loop A to Clk2 (provides 20 GHz full-rate clock to Demux).
3. Loop E to F.
4. Set Divider 2 to 1/2.
5. Set Divider 3 and 4 to 1 (provides 10 GHz clock output).

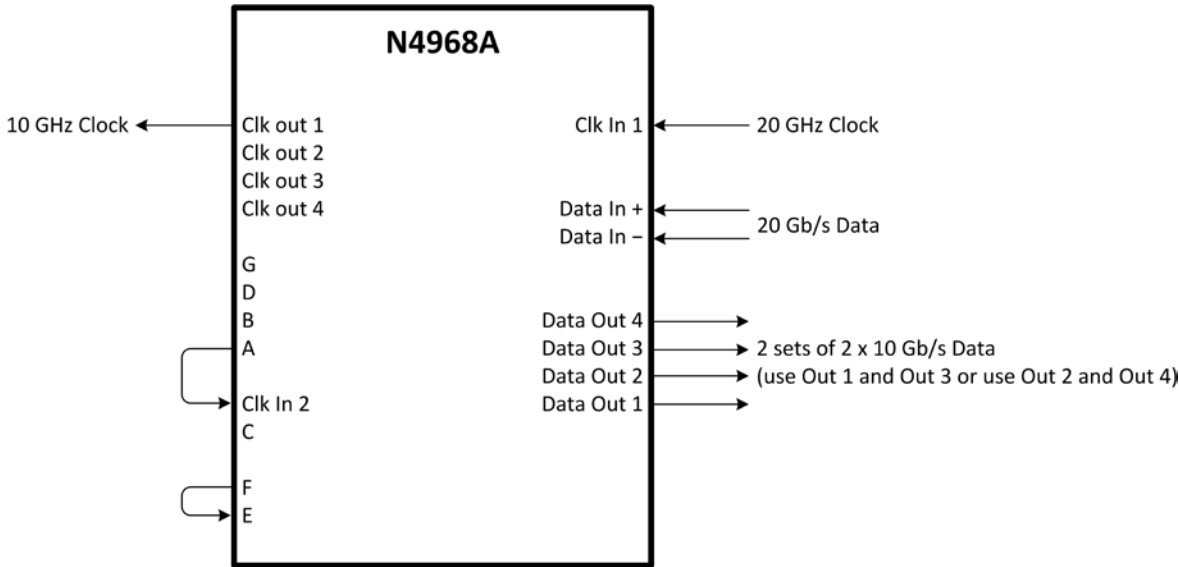

Figure 6. Demux-by-2 example with 20 Gb/s data input

The divide ratio of the divided clock outputs 1 and 2 are the divide ratio of the divider 2 times the divide ratio of the divider 4. Similarly the divide ratio of the divided clock outputs 3 and 4 are the divide ratio of the divider 2 times the divide ratio of the divider 3.

The inputs and the outputs of the dividers are differential and the unused inputs and outputs should be terminated with 50 Ω terminators.

The Data In and Data In/ are differential inputs for the data. These connectors are 1.85 mm female connectors. If the data input is used single ended the input should be connected through a DC block and the unused input should be terminated with a 50 Ω 1.85 mm terminator.

Operation

The clock input to the Demux is routed through the phase shifter to align the clock edge to the data. By turning the phase shifter knob the clock edge can be aligned to the middle of the opening in the input data eye to get an error free output from the Demux. The phase shifter is a 60° per GHz, 18 turns phase shifter.

The demuxed data outputs are routed thru Demux Data Out 1 through Demux Data Out 4 connectors on the front panel. These are 2.92 mm female connectors. They are single ended AC coupled outputs.

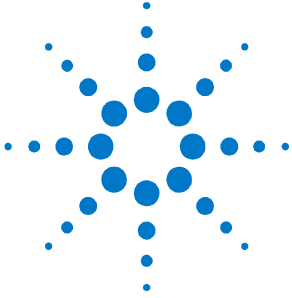

5 Returning the N4968A to Agilent Technologies

If the N4968A fails system verification and you cannot correct the problem, return it to Agilent Technologies for repair following the steps shown below.

1. Record all symptoms.
 2. Contact Agilent Technologies at <http://www.agilent.com/find/assist>.
 3. Use the original packing material or comparable packing material to ship the instrument to Agilent Technologies.
-

© Copyright Agilent Technologies 2012
Third edition, April 2014
Printed in Germany



N4968-91021

