

# Keysight Add Configurable Test Set Upgrade Kit

To Upgrade PNA N5227A Option 400 to Option 401  
Upgrade Kit Order Number: N5227AU-401  
Keysight Kit Number: N5227-60104

NOTICE: This document contains references to Agilent Technologies. Agilent's former Test and Measurement business has become Keysight Technologies. For more information, go to [www.keysight.com](http://www.keysight.com).



---

## WARRANTY STATEMENT

THE MATERIAL CONTAINED IN THIS DOCUMENT IS PROVIDED "AS IS," AND IS SUBJECT TO BEING CHANGED, WITHOUT NOTICE, IN FUTURE EDITIONS. FURTHER, TO THE MAXIMUM EXTENT PERMITTED BY APPLICABLE LAW, KEYSIGHT DISCLAIMS ALL WARRANTIES, EITHER EXPRESS OR IMPLIED WITH REGARD TO THIS MANUAL AND ANY INFORMATION CONTAINED HEREIN, INCLUDING BUT NOT LIMITED TO THE IMPLIED WARRANTIES OF MERCHANTABILITY AND FITNESS FOR A PARTICULAR PURPOSE. KEYSIGHT SHALL NOT BE LIABLE FOR ERRORS OR FOR INCIDENTAL OR CONSEQUENTIAL DAMAGES IN CONNECTION WITH THE FURNISHING, USE, OR PERFORMANCE OF THIS DOCUMENT OR ANY INFORMATION CONTAINED HEREIN. SHOULD KEYSIGHT AND THE USER HAVE A SEPARATE WRITTEN AGREEMENT WITH WARRANTY TERMS COVERING THE MATERIAL IN THIS DOCUMENT THAT CONFLICT WITH THESE TERMS, THE WARRANTY TERMS IN THE SEPARATE AGREEMENT WILL CONTROL.

---

## DFARS/Restricted Rights Notice

If software is for use in the performance of a U.S. Government prime contract or subcontract, Software is delivered and licensed as "Commercial computer software" as defined in DFAR 252.227-7014 (June 1995), or as a "commercial item" as defined in FAR 2.101(a) or as "Restricted computer software" as defined in FAR 52.227-19 (June 1987) or any equivalent agency regulation or contract clause. Use, duplication or disclosure of Software is subject to Keysight Technologies' standard commercial license terms, and non-DOD Departments and Agencies of the U.S. Government will receive no greater than Restricted Rights as defined in FAR 52.227-19(c)(1-2) (June 1987). U.S. Government users will receive no greater than Limited Rights as defined in FAR 52.227-14 (June 1987) or DFAR 252.227-7015 (b)(2) (November 1995), as applicable in any technical data.

---

## Safety Notes

The following safety notes are used throughout this document. Familiarize yourself with each of these notes and its meaning before performing any of the procedures in this document.

---

**WARNING**      **Warning denotes a hazard. It calls attention to a procedure which, if not correctly performed or adhered to, could result in injury or loss of life. Do not proceed beyond a warning note until the indicated conditions are fully understood and met.**

---

---

**CAUTION**      Caution denotes a hazard. It calls attention to a procedure that, if not correctly performed or adhered to, could result in damage to or destruction of the instrument. Do not proceed beyond a caution note until the indicated conditions are fully understood and met.

---

---

## Description of the Upgrade

This upgrade adds the following items to your N5227A Option 400 network analyzer:

- reference mixer switch
- bulkhead connectors for test set front plate
- front panel jumpers
- front panel jumpers cable guards
- front panel overlay replacement
- new cables

After installation of this upgrade, your analyzer will be an N5227A Option 401.

---

## Getting Assistance from Keysight

By internet, phone, or fax, get assistance with all your test and measurement needs.

### Contacting Keysight

Assistance with test and measurements needs and information on finding a local Keysight office are available on the Web at:

<http://www.keysight.com/find/assist>

If you do not have access to the Internet, please contact your Keysight field engineer.

---

**NOTE** In any correspondence or telephone conversation, refer to the Keysight product by its model number and full serial number. With this information, the Keysight representative can determine whether your product is still within its warranty period.

---

---

## Getting Prepared

---

**CAUTION** The PNA contains extremely sensitive components that can be ruined if mishandled. Follow instructions carefully when making cable connections, especially wire harness connections.

The person performing the work accepts responsibility for the full cost of the repair or replacement of damaged components.

---

To successfully install this upgrade kit, you will need the following:

- A license key - refer to “[License Key Redemption](#)” below.
- A PDF copy or a paper copy of the PNA Service Guide - refer to “[Downloading the Online PNA Service Guide](#)” below.
- An ESD-safe work area - refer to “[Protecting Your Workspace from Electrostatic Discharge](#)” below.
- Correct tools - refer to “[Tools Required for the Installation](#)” on page 6.
- Enough time - refer to “[About Installing the Upgrade](#)” on page 6.
- Test equipment for the post-upgrade adjustments and full instrument calibration. To view the equipment list, click the Chapter 3 bookmark “[Tests and Adjustments](#)” in the PDF Service Guide<sup>1</sup>.

## License Key Redemption

---

**NOTE** The enclosed Option Entitlement Certificate is a receipt, verifying that you have purchased a licensed option for the PNA of your choice. You must now use a Keysight Web page to request a license key for the instrument that will receive the option.

---

To enable the option product, you must request a license key from: <http://www.keysight.com/find/softwarelicense>. To complete the request, you will need to gather the following information:

- From the certificate
  - Order number
  - Certificate number
- From your instrument
  - Model number
  - Serial number
  - Host ID

The instrument information is available on the network analyzer – on the analyzer’s **Help** menu, click **About Network Analyzer**.

If you provide an email address, Keysight will promptly email your license key. Otherwise, you will receive your license key via postal mail.

1. See “[Downloading the Online PNA Service Guide](#)” on page 5.

## Downloading the Online PNA Service Guide

To view the online Service Guide for your PNA model number, use the following steps:

1. Go to [www.keysight.com](http://www.keysight.com).
2. In the Search box, enter the model number of the analyzer (Ex: N5242A) and click **Search**.
3. Click **Technical Support > Manuals**.
4. Click **Service Manual**.
5. Click the service guide title to download the PDF file.
6. When the PDF of the Service Guide is displayed, scroll through the Contents section bookmarks to locate the information needed.

## Protecting Your Workspace from Electrostatic Discharge

For information, click on the Chapter 1 bookmark, “Electrostatic Discharge Protection” in the PDF Service Guide<sup>1</sup>.

### ESD Equipment Required for the Installation

Description	Keysight Part Number
ESD grounding wrist strap	9300-1367
5-ft grounding cord for wrist strap	9300-0980
2 x 4 ft conductive table mat and 15-ft grounding wire	9300-0797
ESD heel strap (for use with conductive floors)	9300-1308

1. See “[Downloading the Online PNA Service Guide](#)” on page 5.

## Tools Required for the Installation

Description	Qty	Part Number
T-10 TORX driver - set to 9 in-lbs (1.02 N.m)	1	N/A
T-20 TORX driver - set to 21 in-lbs (2.38 N.m)	1	N/A
5/16-in (8 mm) nutsetter or open end torque wrench - set to 10 in-lbs (1.13 N.m)	1	N/A
9 mm nutsetter or open end torque wrench - set to 21 in-lbs (2.38 N.m)	1	N/A

**CAUTION** Use a 5/16-in torque wrench set to 10 in-lbs on all cable connections except the front and rear panel bulkhead connectors. On these, use a 9 mm nutsetter or open end torque wrench set to 21 in-lb.

## About Installing the Upgrade

Products affected . . . . .	N5227A Option 400
Installation to be performed by . . . . .	Keysight service center or personnel qualified by Keysight
Estimated installation time . . . . .	2 hours
Estimated adjustment time . . . . .	0.5 hour
Estimated full instrument calibration time . . . . .	4.5 hours

## Items Included in the Upgrade Kit<sup>1</sup>

Check the contents of your kit against the following list. If any part is missing or damaged, contact Keysight Technologies. Refer to [“Getting Assistance from Keysight” on page 3](#).

**Table 1 Contents of Upgrade Kit N5227-60104**

Ref Desig.	Description	Qty	Part Number
--	Installation note (this document)	1	N5227-90104
A37	Reference mixer switch	1	5087-7759
--	Bracket (for A37 reference mixer switch)	1	N5245-00024
--	Machine screw, M3 x 8, pan head (to attach bracket to reference mixer switch; to attach reference mixer switch assembly to deck)	5	0515-0372
--	Cable clamp	12	1400-1334
--	Cable tie	5	1400-0249
--	Cable guard- middle	1	N5242-00030
--	Cable guard - side	2	N5242-00029
--	Bulkhead connector for test set front plate	24	5065-4673
--	Lock washer for bulkhead connector	24	1250-3310
--	Nut for bulkhead connector	24	1250-3516
--	Front panel overlay	1	N5227-80005
W12	RF cable, A60 port 1 70 GHz doubler to W11	1	N5247-20059
W16	RF cable, A61 port 3 70 GHz doubler to W15	1	N5247-20060
W20	RF cable, A62 port 4 70 GHz doubler to W19	1	N5247-20015
W27	RF cable, A60 port 1 70 GHz doubler to A29 port 1 receiver coupler	1	N5247-20074
W28	RF cable, A61 port 3 70 GHz doubler to A30 port 3 receiver coupler	1	N5247-20052
W29	RF cable, A62 port 4 70 GHz doubler to A31 port 4 receiver coupler	1	N5247-20074
W30	RF cable, A63 port 2 70 GHz doubler to A32 port 2 receiver coupler	1	N5247-20052
W31	RF cable, A29 port 1 receiver coupler to front-panel port 1 SOURCE OUT	1	N5247-20037
W32	RF cable, Port 1 CPLR THRU to A33 port 1 coupler	1	N5247-20016
W33	RF cable, A29 port 1 receiver coupler to A37 reference mixer switch	1	N5247-20078
W34	RF cable, A33 port 1 coupler to front-panel port 1 CPLR ARM	1	N5247-20082
W35	RF cable, A30 port 3 receiver coupler to front-panel port 3 SOURCE OUT	1	N5247-20023
W36	RF cable, Port 3 CPLR THRU to A34 port 3 coupler	1	N5247-20006
W37	RF cable, A30 port 3 receiver coupler to front-panel REF 3 SOURCE OUT	1	N5247-20077

1. In addition to the upgrade kit, the shipment includes an Option Entitlement Certificate. Refer to [“License Key Redemption” on page 4](#) for important information about this certificate.



**Table 1 Contents of Upgrade Kit N5227-60104**

<b>Ref Desig.</b>	<b>Description</b>	<b>Qty</b>	<b>Part Number</b>
W38	RF cable, A34 port 3 coupler to front-panel port 3 CPLR ARM	1	N5247-20007
W39	RF cable, A31 port 4 receiver coupler to front-panel port 4 SOURCE OUT	1	N5247-20035
W40	RF cable, Port 4 CPLR THRU to A35 port 4 coupler	1	N5247-20017
W41	RF cable, A31 port 4 receiver coupler to front-panel REF 4 SOURCE OUT	1	N5247-20075
W42	RF cable, A35 port 4 coupler to front-panel port 4 CPLR ARM	1	N5247-20026
W43	RF cable, A32 port 2 receiver coupler to front-panel port 2 SOURCE OUT	1	N5247-20036
W44	RF cable, Port 2 CPLR THRU to A36 port 2 coupler	1	N5247-20018
W45	RF cable, A32 port 2 receiver coupler to front-panel REF 2 SOURCE OUT	1	N5247-20076
W46	RF cable, A36 port 2 coupler to front-panel port 2 CPLR ARM	1	N5247-20019
W47	RF cable, Port 1 RCVR A IN to A27 mixer brick (A)	1	N5247-20053
W48	RF cable, Port 3 RCVR C IN to A28 mixer brick (C)	1	N5247-20063
W49	RF cable, Port 4 RCVR D IN to A28 mixer brick (D)	1	N5247-20073
W50	RF cable, Port 2 RCVR B IN to A27 mixer brick (B)	1	N5247-20054
W51	RF cable, A37 reference mixer switch to front-panel REF 1 SOURCE OUT	1	N5247-20011
W52	RF cable, REF 1 RCVR R1 IN to A37 reference mixer switch	1	N5247-20012
W53	RF cable, A37 reference mixer switch to A27 mixer brick (R1)	1	N5247-20048
W54	RF cable, REF 3 RCVR R3 IN to A28 mixer brick (R3)	1	N5247-20062
W55	RF cable, REF 4 RCVR R4 IN to 3 dB pad on A28 mixer brick (R4)	1	N5247-20067
W56	RF cable, REF 2 RCVR R2 IN to A27 mixer brick (R2)	1	N5247-20055
W60	RF cable, Front panel jumper	12	N5247-20107
--	Wire harness, A23 test set motherboard J554 to A37 reference mixer switch	1	8121-0966

---

**NOTE** Extra quantities of items such as protective plastic caps, screws, cable ties, and cable clamps may be included in this upgrade kit. It is normal for some of these items to remain unused after the upgrade is completed.

---

---

## Installation Procedure for the Upgrade

The network analyzer must be in proper working condition prior to installing this option. Any necessary repairs must be made before proceeding with this installation.

---

**WARNING**     **This installation requires the removal of the analyzer's protective outer covers. The analyzer must be powered down and disconnected from the mains supply before performing this procedure.**

---

### Overview of the Installation Procedure

- Step 1. Obtain Keyword and Verify Information.
- Step 2. Remove Outer Cover.
- Step 3. Remove Front Panel Assembly.
- Step 4. Install Bulkhead Connector Hardware on Test Set Front Plate Assembly.
- Step 5. Remove Some Existing Cables.
- Step 6. Remove 3 dB Pad from A27 Mixer Brick (1).
- Step 7. Remove Receiver Coupler Assemblies from Large Brackets Underneath.
- Step 8. Remove Brackets That Were Beneath Receiver Coupler Assemblies.
- Step 9. Reinstall Receiver Coupler Assemblies To Test Set Deck.
- Step 10. Assemble A37 Reference Mixer Switch Assembly.
- Step 11. Install A37 Reference Mixer Switch Assembly.
- Step 12. Install Cables.
- Step 13. Remove Old Lower Front Panel Overlay.
- Step 14. Reinstall Front Panel Assembly.
- Step 15. Install New Lower Front Panel Overlay.
- Step 16. Install Front Panel Jumpers.
- Step 17. Position the Cables and Wires to Prevent Pinching.
- Step 18. Reinstall Outer Cover.
- Step 19. Enable Option 401.
- Step 20. Perform Post-Upgrade Adjustments and Calibration.
- Step 21. Prepare the PNA for the User.

## Step 1. Obtain Keyword and Verify Information

Follow the instructions on the Option Entitlement Certificate supplied to obtain a license key for installation of this upgrade. Refer to [“License Key Redemption” on page 4](#).

Verify that the model number, serial number, and option number information on the license key match those of the instrument on which this upgrade will be installed.

If the model number, serial number, or option number do not match those on your license key, you will not be able to install the option. If this is the case, contact Keysight for assistance before beginning the installation of this upgrade. Refer to [“Contacting Keysight” on page 3](#).

Once the license key has been received and the information verified, you can proceed with the installation at step 2.

## Step 2. Remove Outer Cover

For instructions, click the Chapter 7 bookmark “Removing the Covers” in the PDF Service Guide<sup>1</sup>.

## Step 3. Remove Front Panel Assembly

For instructions, click the Chapter 7 bookmark “Removing and Replacing the Front Panel Assembly” in the PDF Service Guide<sup>1</sup>.

## Step 4. Install Bulkhead Connector Hardware on Test Set Front Plate Assembly

Install 24 bulkhead connectors (5065-4673), along with lock washers (1250-3310) and nuts (1250-3516) to the test set front plate along with washers and nuts (hardware equipped with connector). Torque all nuts to 21 in-lbs. Refer to [Figure 11 on page 23](#) to see the location of the bulkhead connectors.

---

1. See [“Downloading the Online PNA Service Guide” on page 5](#).

## Step 5. Remove Some Existing Cables

---

**CAUTION** Be careful not to damage the center pins of the semirigid cables. Some flexing of the cables may be necessary but do not over-bend them.

---

---

**NOTE** When removing a cable, also remove the plastic cable clamp, if present. It is normal for some of the cable clamp's adhesive to remain.

---

1. Place the analyzer bottom-side up on a flat surface.
2. Remove the following cables. To see an image showing the location of these cables, click the Chapter 6 bookmark "Bottom RF Cables, Standard 4-Port Configuration, Option 400" in the PDF Service Guide<sup>1</sup>.

These cables may be discarded - they will not be reinstalled.

- W30 (N5227-20045) A63 port 2 70 GHz doubler to A32 port 2 receiver coupler
- W20 (N5227-20043) A62 port 4 70 GHz doubler to W19
- W27 (N5227-20044) A60 port 1 70 GHz doubler to A29 port 1 receiver coupler
- W28 (N5227-20045) A61 port 3 70 GHz doubler to A30 port 3 receiver coupler
- W16 (N5227-20042) A61 port 3 70 GHz doubler to W15
- W12 (N5227-20041) A60 port 1 70 GHz doubler to W11
- W29 (N5227-20044) A62 port 4 70 GHz doubler to A31 port 4 receiver coupler
- W133 (N5227-20017) A31 port 4 receiver coupler to A35 port 4 coupler
- W134 (N5227-20018) A32 port 2 receiver coupler to A36 port 2 coupler
- W132 (N5227-20016) A30 port 3 receiver coupler to A34 port 3 coupler
- W131 (N5227-20015) A29 port 1 receiver coupler to A33 port 1 coupler
- W136 (N5227-20014) A34 port 3 coupler to A28 mixer brick (C)
- W135 (N5227-20011) A33 port 1 coupler to A27 mixer brick (A)
- W127 (N5227-20002) A29 port 1 receiver coupler to 3 dB pad on A27 mixer brick (R1)
- W137 (N5227-20013) A35 port 4 coupler to A28 mixer brick (D)
- W130 (N5227-20001) A32 port 2 receiver coupler to A27 mixer brick (R2)
- W138 (N5227-20012) A36 port 2 coupler to A27 mixer brick (B)
- W128 (N5227-20009) A30 port 3 receiver coupler to A28 mixer brick (R3)
- W129 (N5227-20010) AA31 port 4 receiver coupler to 3 dB pad on A28 mixer brick (R4)

---

1. See "[Downloading the Online PNA Service Guide](#)" on page 5.

## Step 6. Remove 3 dB Pad from A27 Mixer Brick (1)

Refer to [Figure 1](#) for this step of the procedure.

**Figure 1**      **Location of 3 dB Pad to be Removed**

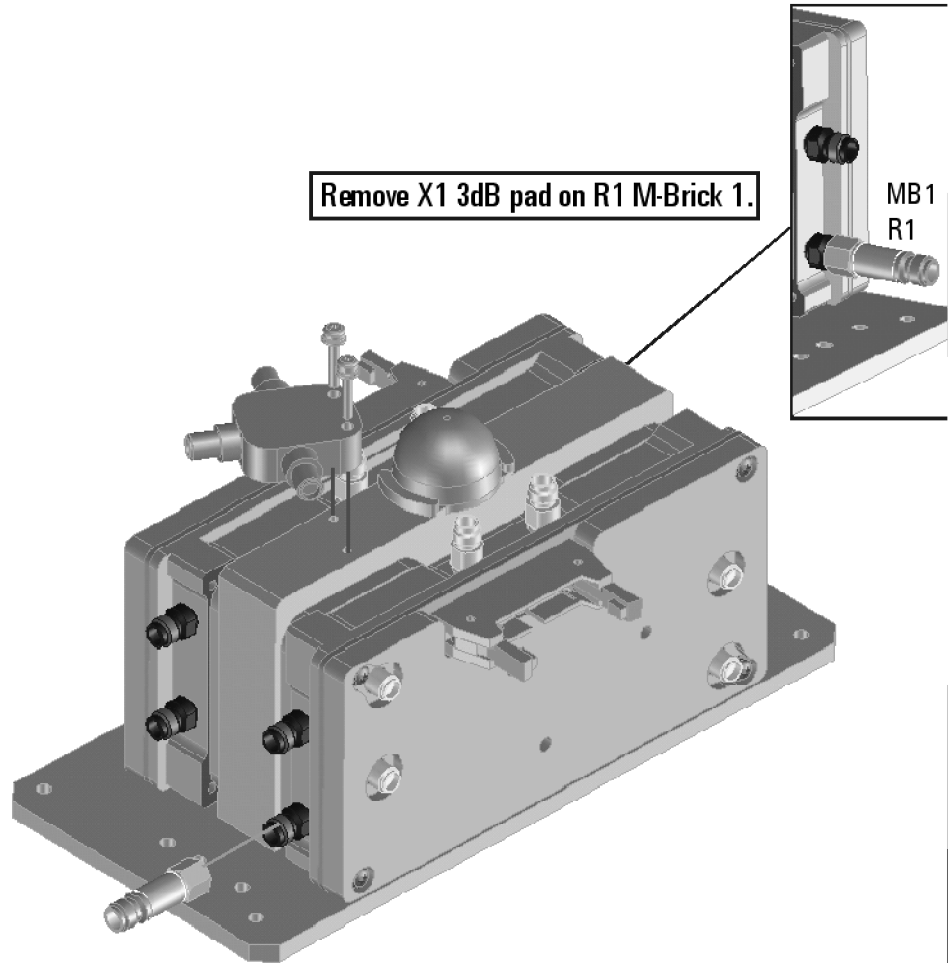

N5227\_104\_01

## Step 7. Remove Receiver Coupler Assemblies from Large Brackets Underneath

Refer to [Figure 2](#) for this step of the procedure.

**Figure 2** Location of Receiver Couplers to be Removed

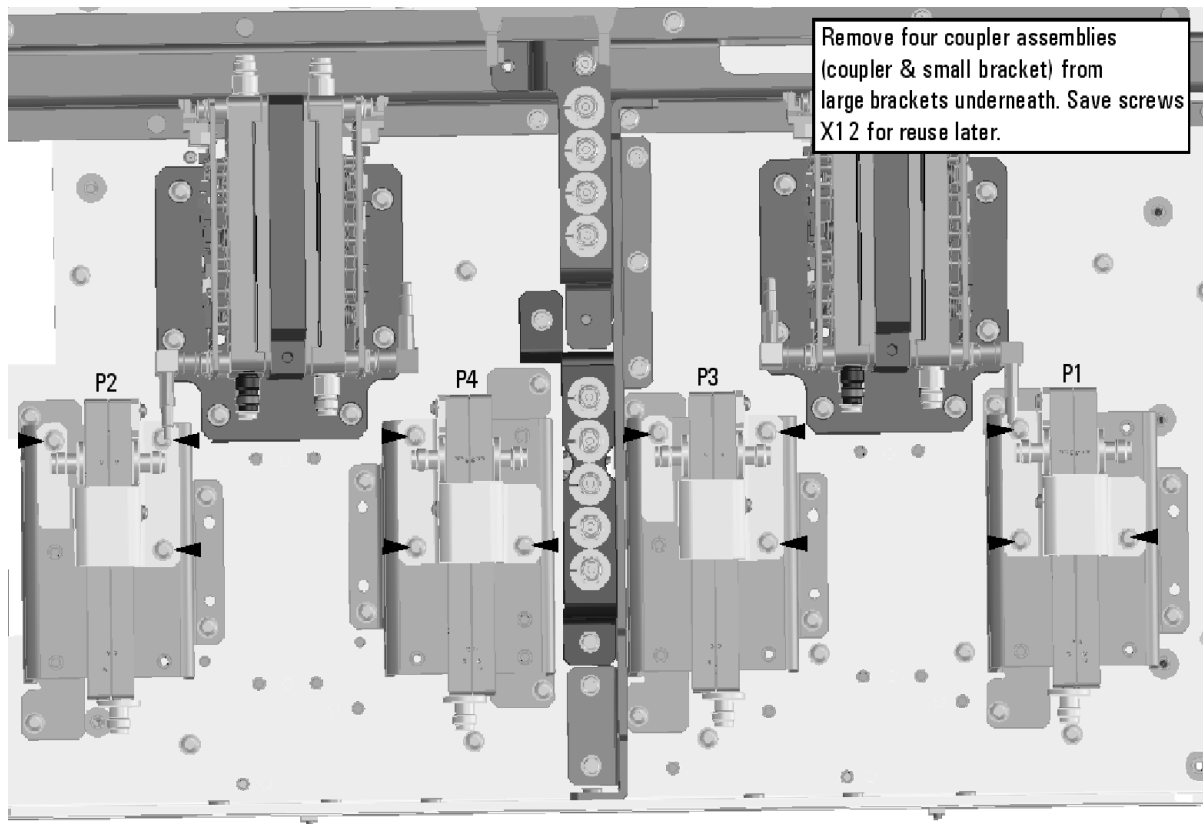

N5227\_104\_08

## Step 8. Remove Brackets That Were Beneath Receiver Coupler Assemblies

Refer to [Figure 3](#) for this step of the procedure.

**Figure 3** Location of Brackets to be Removed

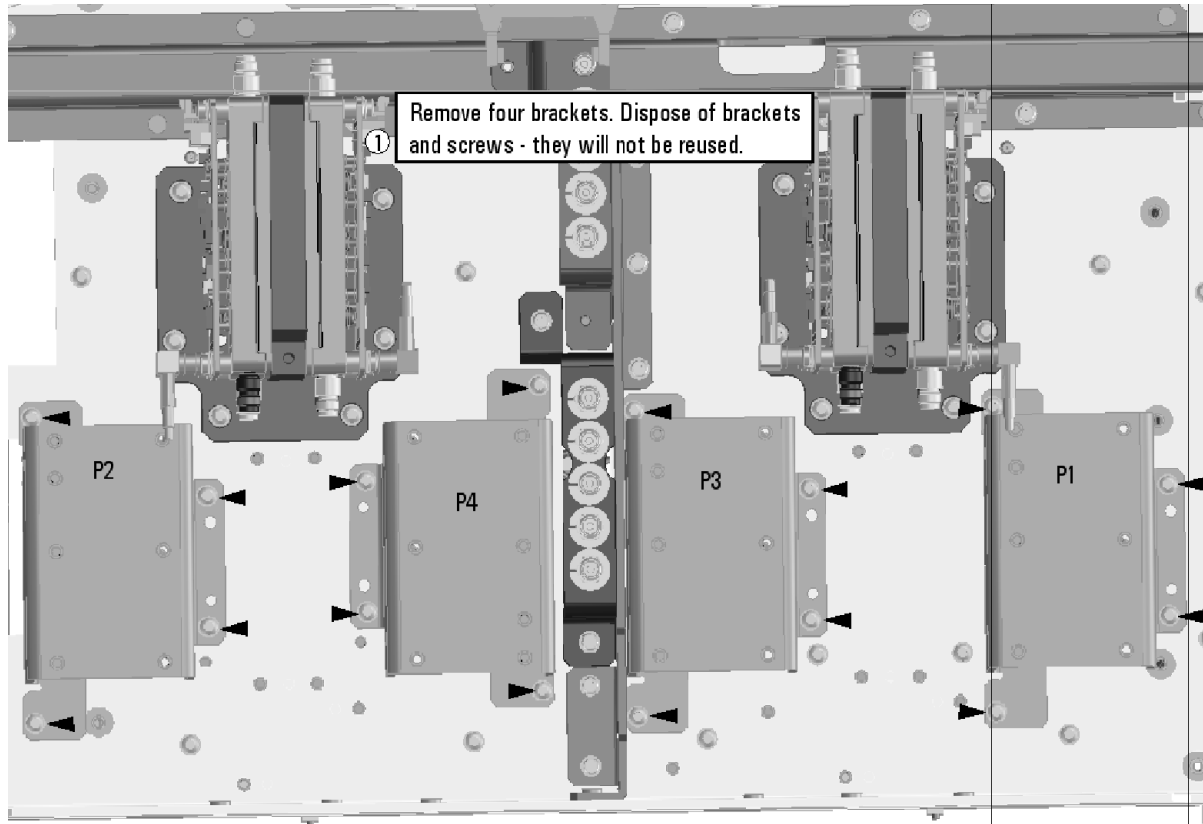

N5227\_104\_09

## Step 9. Reinstall Receiver Coupler Assemblies To Test Set Deck

Refer to [Figure 4](#) for this step of the procedure.

**Figure 4** Receiver Coupler Assemblies Reinstallation

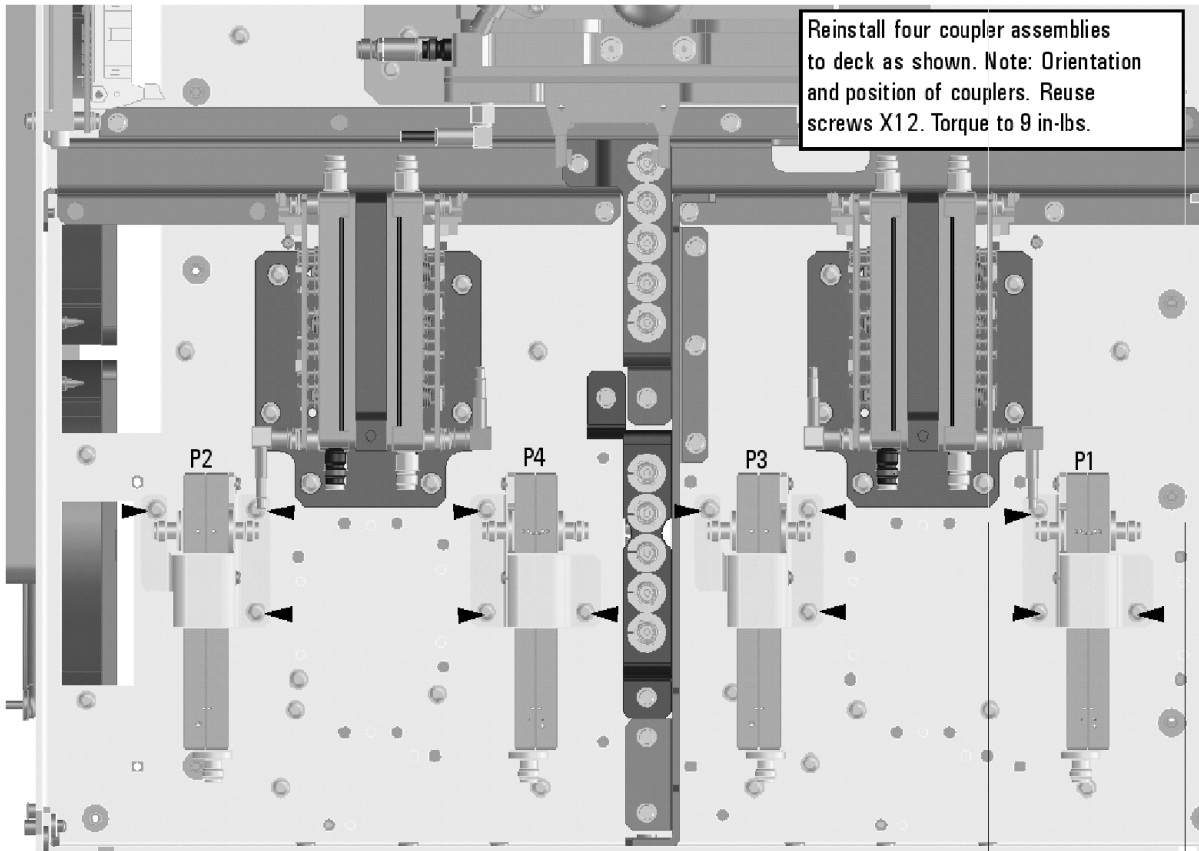

N5227\_104\_02



## Step 10. Assemble A37 Reference Mixer Switch Assembly

Assemble the N5245-00024 bracket to the 5087-7759 Reference Mixer Switch using two 0515-0372 screws. Torque the screws to 9 in-lbs. New parts are listed in [Table 1 on page 7](#). Use a T-10 TORX driver to tighten all screws to 9 in-lbs.

## Step 11. Install A37 Reference Mixer Switch Assembly

Refer to [Figure 5](#) for this step of the procedure.

**Figure 5** Mixer Switch Assembly Installation

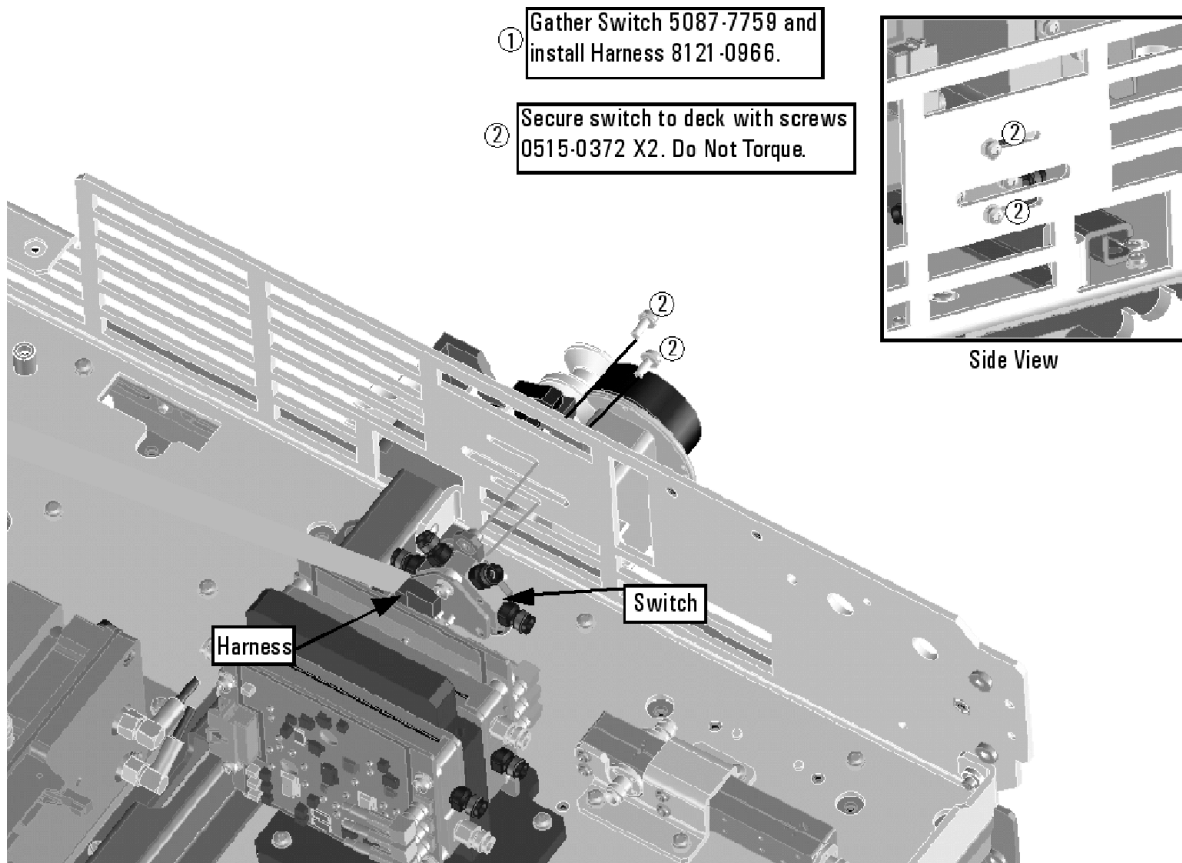

N5227\_104\_03

## Step 12. Install Cables

---

**CAUTION** Follow instructions carefully when making cable connections, especially wire harness connections. Incorrect connections can destroy components, resulting in additional customer costs.

---

---

**CAUTION** Be careful not to damage the center pins of the semirigid cables. Some flexing of the cables may be necessary but do not over-bend them.

---

### Install Semirigid Cables

To see an image showing the location of these cables, click the Chapter 6 bookmarks “Bottom RF Cables, 4-Port Configuration, Option 401” in the PDF Service Guide<sup>1</sup>. New parts are listed in [Table 1 on page 7](#).

Install the following cables in the order listed.

- W50 (N5247-20054) Port 2 RCVR B IN to A27 mixer brick (B)
- W44 (N5247-20018) Port 2 CPLR THRU to A36 port 2 coupler
- W46 (N5247-20019) A36 port 2 coupler to front-panel port 2 CPLR ARM
- W43 (N5247-20036) A32 port 2 receiver coupler to front-panel port 2 SOURCE OUT
- W40 (N5247-20017) Port 4 CPLR THRU to A35 port 4 coupler
- W45 (N5247-20076) A32 port 2 receiver coupler to front-panel REF 2 SOURCE OUT

\* As shown in [Figure 7 on page 19](#), install two cable clamps (part number 1400-1334) to secure W45 (part number N5247-20076).

---

1. See [“Downloading the Online PNA Service Guide” on page 5](#).

**Figure 6**      **Location of Cable Clamps to Secure W45**

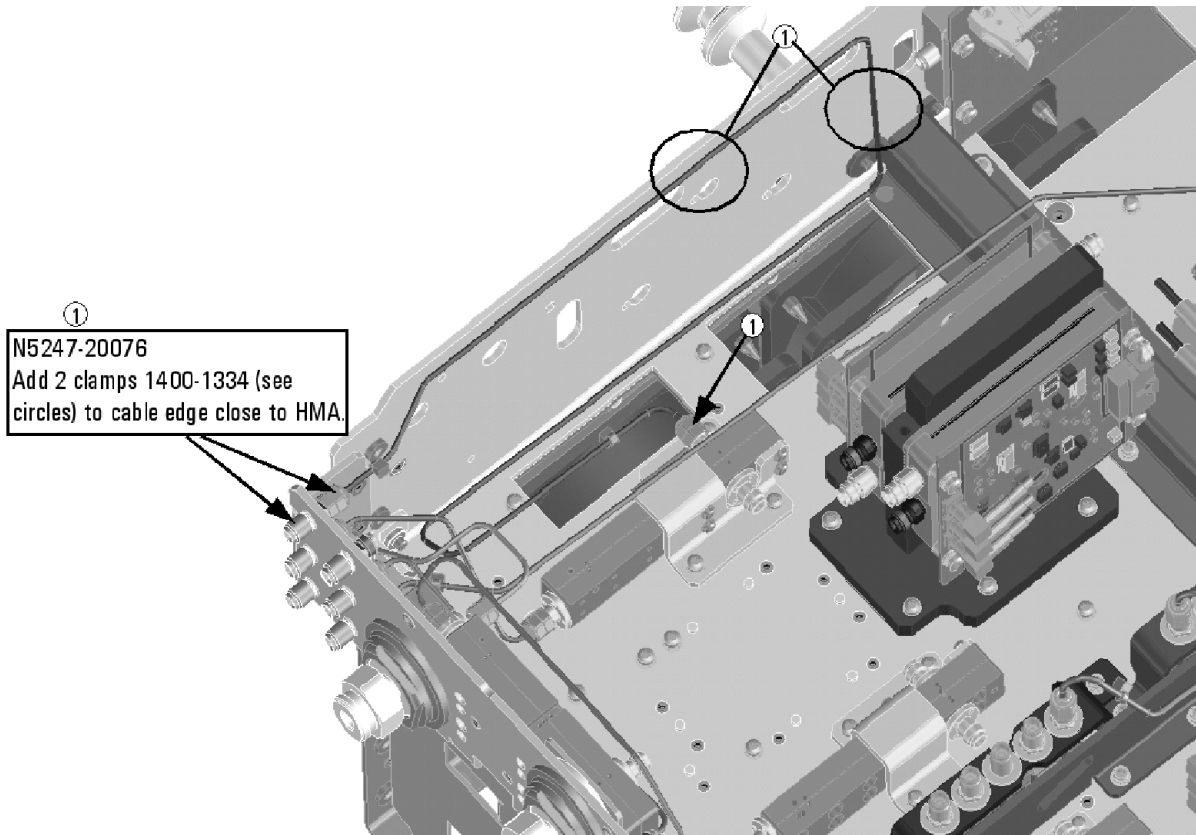

N5227\_104\_04

- W56 (N5247-20055) REF 2 RCVR R2 IN to A27 mixer brick (R2)
- W55 (N5247-20067) REF 4 RCVR R4 IN to 3 dB pad on A28 mixer brick (R4)
- W49 (N5247-20073) Port 4 RCVR D IN to A28 mixer brick (D)
- W42 (N5247-20026) A35 port 4 coupler to front-panel port 4 CPLR ARM
- W39 (N5247-20035) A31 port 4 receiver coupler to front-panel port 4 SOURCE OUT
- W41 (N5247-20075) A31 port 4 receiver coupler to front-panel REF 4 SOURCE OUT

\* As shown in **Figure 7 on page 19**, install cable clamp (part number 1400-1334) to secure W41 (part number N5247-20075).

**Figure 7**      **Location of Cable Clamp to Secure W41**

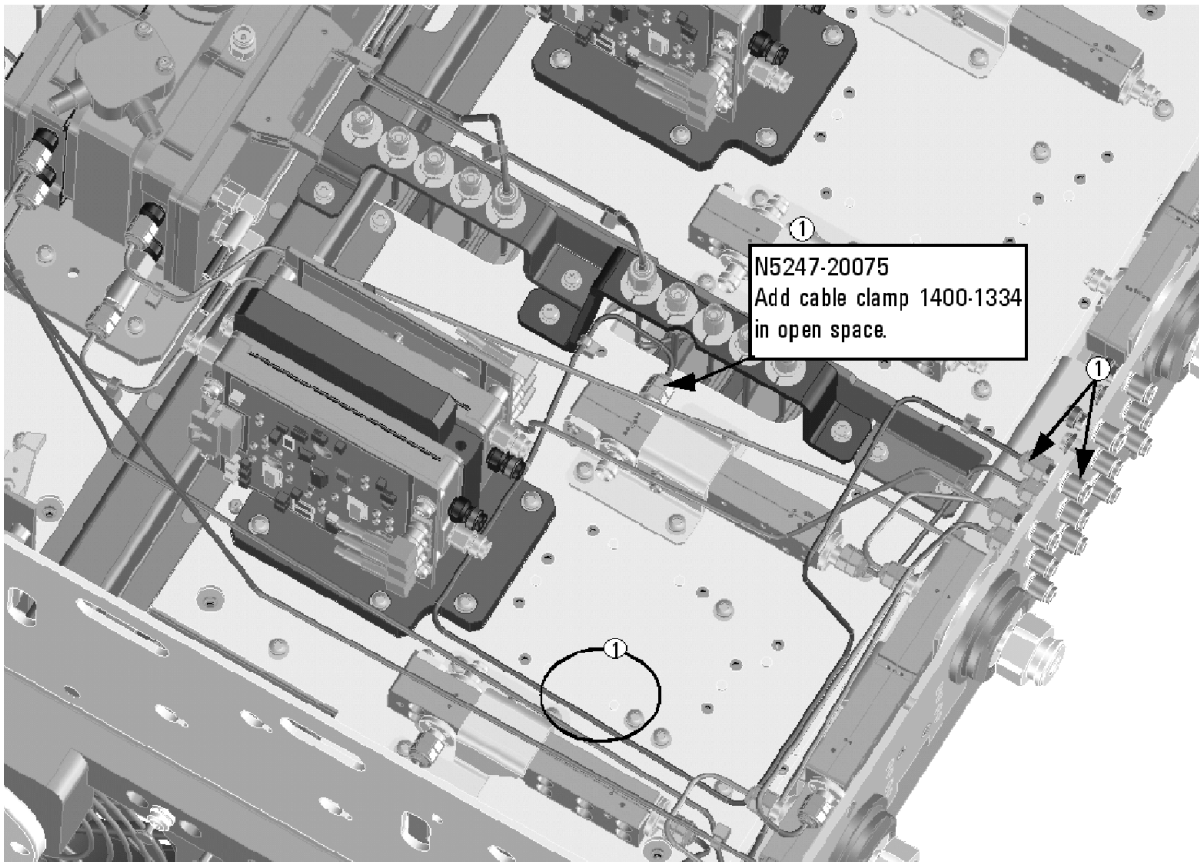

N5227\_104\_05

- W37 (N5247-20077) A30 port 3 receiver coupler to front-panel REF 3 SOURCE OUT
- W48 (N5247-20063) Port 3 RCVR C IN to A28 mixer brick (C)
- W38 (N5247-20007) A34 port 3 coupler to front-panel port 3 CPLR ARM
- W35 (N5247-20023) A30 port 3 receiver coupler to front-panel port 3 SOURCE OUT
- W32 (N5247-20016) Port 1 CPLR THRU to A33 port 1 coupler
- W36 (N5247-20006) Port 3 CPLR THRU to A34 port 3 coupler
- W51 (N5247-20011) A37 reference mixer switch to front-panel REF 1 SOURCE OUT
- W33 (N5247-20078) A29 port 1 receiver coupler to A37 reference mixer switch

\* As shown in **Figure 7 on page 19**, install three cable clamps (part number 1400-1334) to secure W33 (part number N5247-20078).

**Figure 8**      **Location of Cable Clamp to Secure W33**

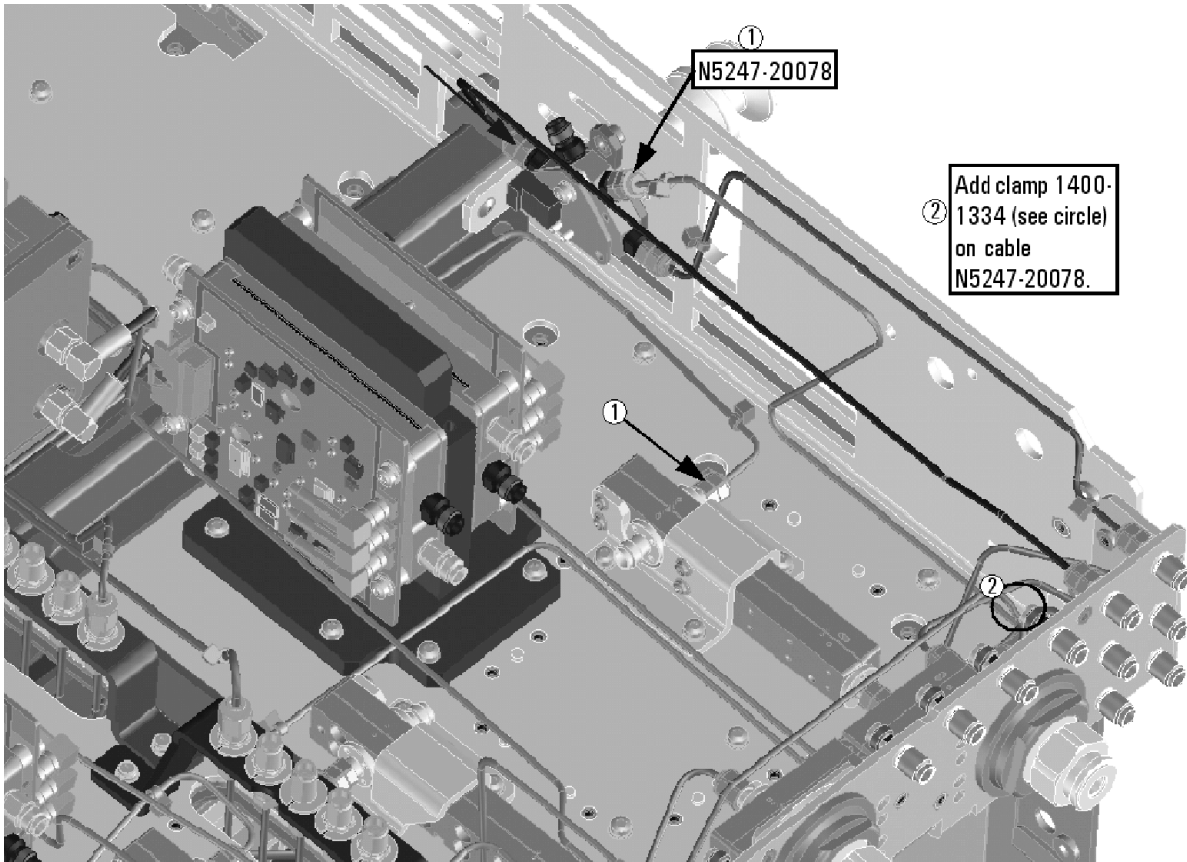

N5227\_104\_06

- W52 (N5247-20012) REF 1 RCVR R1 IN to A37 reference mixer switch
- W47 (N5247-20053) Port 1 RCVR A IN to A27 mixer brick (A)
- W34 (N5247-20082) A33 port 1 coupler to front-panel port 1 CPLR ARM
- W31 (N5247-20037) A29 port 1 receiver coupler to front-panel port 1 SOURCE OUT
- W53 (N5247-20048) A37 reference mixer switch to A27 mixer brick (R1)
- W54 (N5247-20062) REF 3 RCVR R3 IN to A28 mixer brick (R3)

\* As shown in [Figure 9 on page 21](#), install a cable tie (part number 1400-0249) to secure W54 (part number N5247-20062).



**Figure 9**      **Location of Cable Tie to Secure W54**

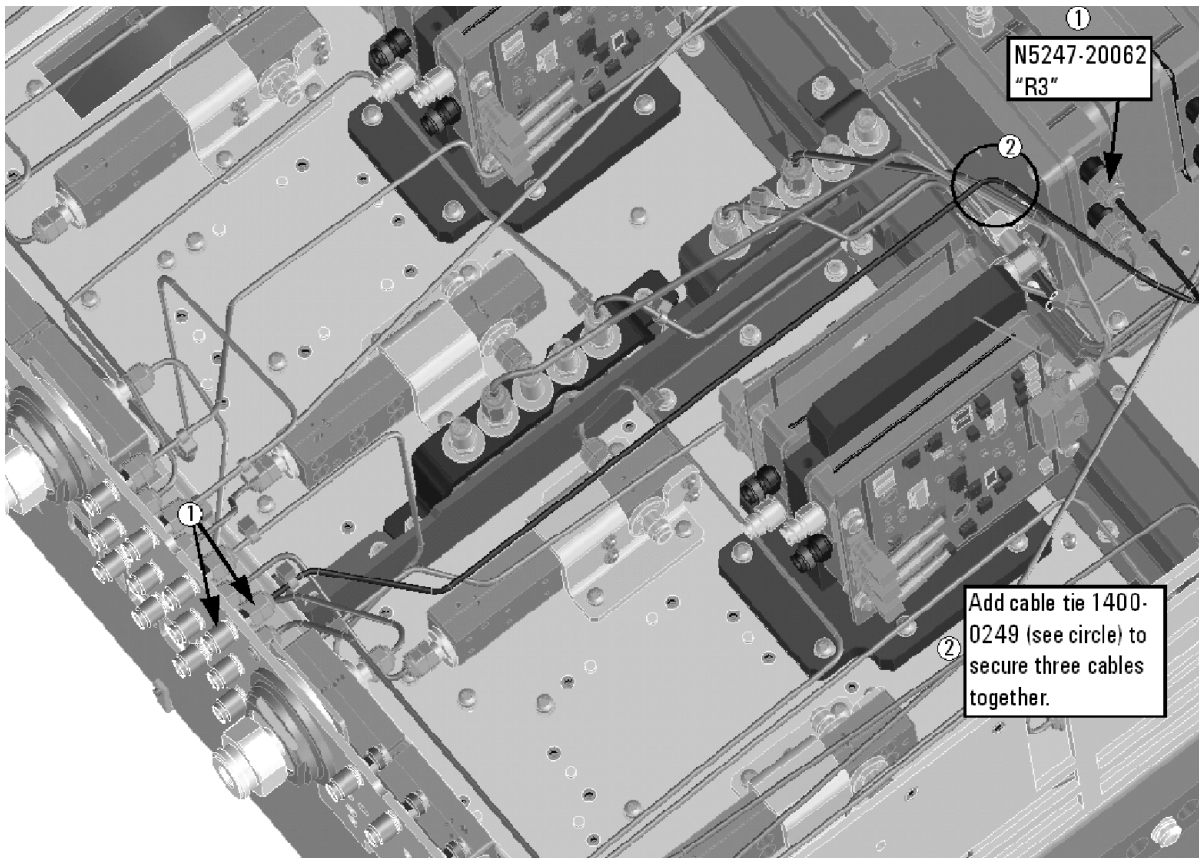

N5227\_104\_07

- W29 (N5247-20074) A62 port 4 70 GHz doubler to A31 port 4 receiver coupler
- W28 (NN5247-20052) A61 port 3 70 GHz doubler to A30 port 3 receiver coupler
- W16 (N5247-20060) A61 port 3 70 GHZ doubler to W15
- W12 (N5247-20059) A60 port 1 70 GHz doubler to W11
- W27 (N5247-20074) A60 port 1 70 GHz doubler to A29 port 1 receiver coupler
- W20 (N5247-20015) A62 port 4 70 GHZ doubler to W19
- W30 (N5247-20052) A63 port 2 70 GHz doubler to A32 port 2 receiver coupler

### **Install Wire Harness**

To see an image showing the location of this wire harness, click the Chapter 6 bookmarks “Bottom Ribbon Cables and Wire Harnesses, 4-Port, Option 401” in the PDF Service Guide<sup>1</sup>. New parts are listed in [Table 1 on page 7](#).

If not already done, install the following wire harness:

- ----- (8121-0966) A23 test set motherboard J554 to A37 reference mixer switch

1. See [“Downloading the Online PNA Service Guide” on page 5](#).

### Step 13. Remove Old Lower Front Panel Overlay

Refer to **Figure 10** for this step of the procedure. New parts are listed in **Table 1** on page 7.

1. From the back side of the front panel, use a blunt object in the cutouts in the lower front dress panel to push on the old overlay (item ①) and separate it from the front dress panel.
2. From the front side of the front panel, pull off the overlay completely and discard it.
3. Remove any adhesive remaining on the front panel.

**Figure 10** Lower Front Panel Overlay Replacement

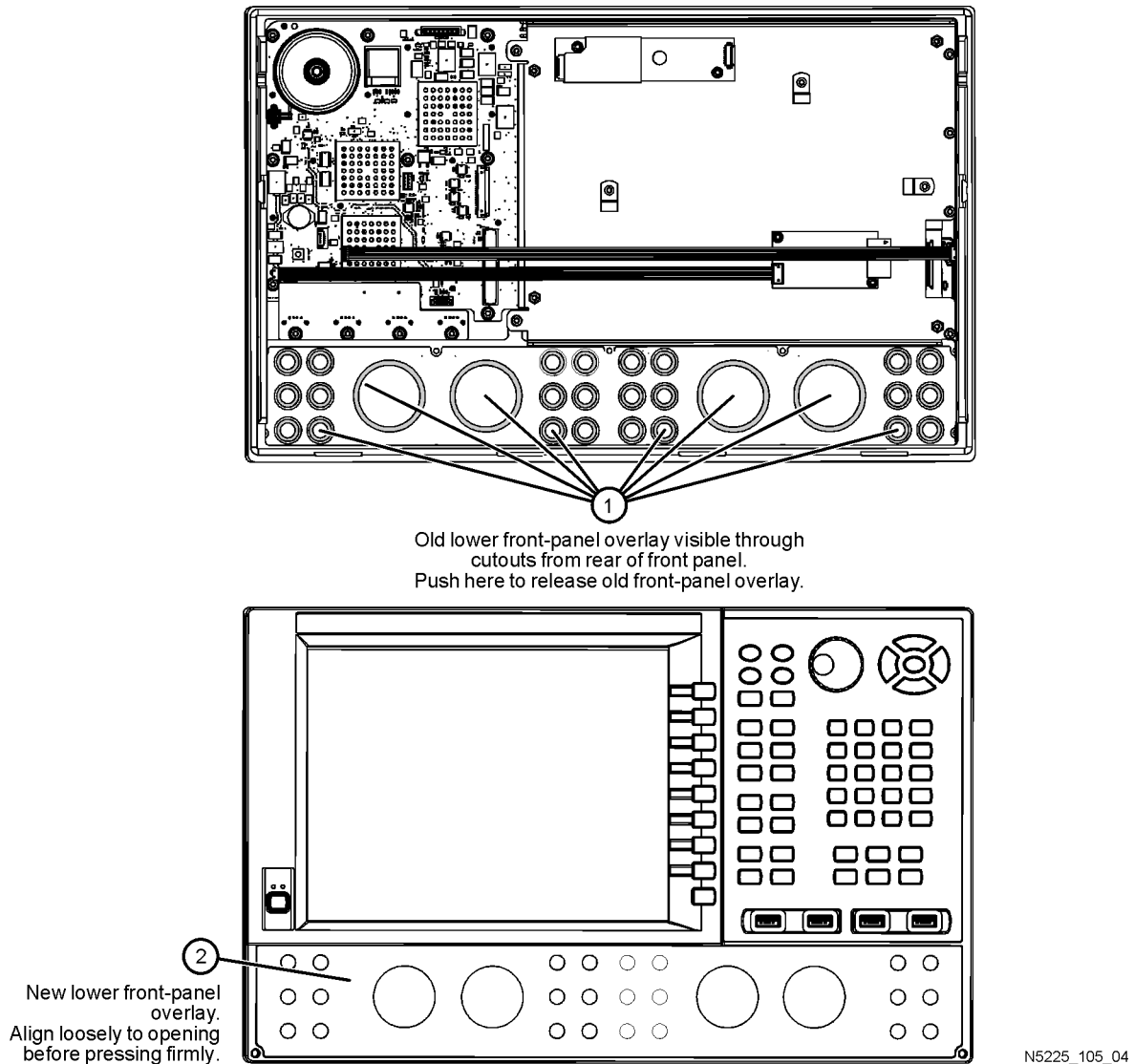

## Step 14. Reinstall Front Panel Assembly

For instructions on reinstalling the front panel assembly, click the Chapter 7 bookmark “Removing and Replacing the Front Panel Assembly” in the PDF Service Guide<sup>1</sup>.

## Step 15. Install New Lower Front Panel Overlay

Refer to [Figure 10 on page 22](#) for this step of the procedure. New parts are listed in [Table 1 on page 7](#).

1. Remove the protective backing from the new front panel overlay, N5227-80005 (item ②).
2. Starting from either side, *loosely* place the overlay in the recess on the lower front panel, ensuring that it fits tightly against the edges of the recess.
3. Once the overlay is in place, press it firmly onto the frame to secure it.

## Step 16. Install Front Panel Jumpers

As shown in [Figure 11](#), install 12 front panel jumper cables (reference designator W60; part number N5247-20107).

**Figure 11** Front Panel Jumper Cables Installation



① Install 12x jumper cables N5247-20107 and torque to 10" lbs

N5227\_105\_10

1. See [“Downloading the Online PNA Service Guide” on page 5](#).



## Step 17. Position the Cables and Wires to Prevent Pinching

On the top side of the PNA, carefully position the grey flex cables so they can't be pinched between the covers and the rails.

On the bottom side of the PNA, carefully fold or push down the ribbon cables and wires so they can't be pinched between the hardware and the outer cover. Ribbon cables and wires must never be positioned on top of hardware.

## Step 18. Reinstall Outer Cover

For instructions, click the Chapter 7 bookmark "Removing the Covers" in the PDF Service Guide<sup>1</sup>.

## Step 19. Enable Option 401

### Procedure Requirements

- The analyzer must be powered up and operating to perform this procedure.
- The Network Analyzer program must be running.
- A keyboard must be connected to the network analyzer.

### Option Enable Procedure

1. To start the option enable utility, press UTILITY **System**, then **Service**, then **Option Enable**. An option enable dialog box will appear.
2. Click the arrow in the **Select Desired Option** box. A list of available options will appear.
3. In the **Select Desired Option** list, click **401 - Configurable Test Set**.
4. Using the keyboard, enter the license key in the box provided. The license key is printed on the the license message you received from Keysight. Enter this key *exactly* as it is printed on the message.
5. Click **Enable**.
6. Click **Yes** in answer to the displayed question in the **Restart Analyzer?** box.
7. When the installation is complete, click **Exit**.

### Option Verification Procedure

Once the analyzer has restarted and the Network Analyzer program is again running:

1. On the analyzer's **Help** menu, click **About Network Analyzer**.
2. Verify that "401" is listed after "Options:" in the display. Click **OK**.

---

**NOTE** If Option 401 has not been enabled, perform the "Option Enable Procedure" again. If the option is still not enabled, contact Keysight Technologies. Refer to "Getting Assistance from Keysight" on page 3.

---

## Step 20. Perform Post-Upgrade Adjustments and Calibration

### Adjustments

The following adjustments must be made due to the hardware changes of the analyzer.

- source adjustment
- receiver adjustment

These adjustments are described in the PNA Service Guide and in the PNA on-line HELP. A list of equipment required to perform these adjustments is also found in the service guide.

To view this service guide information, click the Chapter 3 bookmark “Tests and Adjustments” in the PDF Service Guide<sup>1</sup>.

After the specified adjustments have been performed, the analyzer should operate and phase lock over its entire frequency range.

### Operator’s Check

Perform the Operator’s Check to check the basic functionality of the analyzer. For instructions, click the Chapter 3 bookmark “Tests and Adjustments” in the PDF Service Guide<sup>1</sup>.

If you experience difficulty with the basic functioning of the analyzer, contact Keysight. Refer to [“Contacting Keysight” on page 3](#).

### Calibration

Although the analyzer functions, its performance relative to its specifications has not been verified. It is recommended that a full instrument calibration be performed using the analyzer’s internal performance test software. To view information on the performance test software, click the Chapter 3 bookmark “Tests and Adjustments” in the PDF Service Guide<sup>1</sup>.

## Step 21. Prepare the PNA for the User

1. If necessary, reinstall front jumper cables.
2. Install the cable guards, pushing them over the front jumper cables until the cushioning material touches the front panel of the PNA.
3. Install the dust caps on the test ports.
4. Clean the analyzer, as needed, using a damp cloth.

---

1. See [“Downloading the Online PNA Service Guide” on page 5](#).



This information is subject to change without notice.  
© Keysight Technologies 2011, 2014  
August 2014



N5227-90103  
[www.keysight.com](http://www.keysight.com)