



Agilent U1190A Series Handheld Clamp Meters

Service Guide



Agilent Technologies

Notices

© Agilent Technologies, Inc., 2012–2013

No part of this manual may be reproduced in any form or by any means (including electronic storage and retrieval or translation into a foreign language) without prior agreement and written consent from Agilent Technologies, Inc. as governed by United States and international copyright laws.

Manual Part Number

U1191-90014

Edition

Third Edition, April 3, 2013

Agilent Technologies, Inc.
5301, Stevens Creek Blvd.
Santa Clara, CA 95051 USA

Warranty

The material contained in this document is provided “as is,” and is subject to change, without notice, in future editions. Further, to the maximum extent permitted by the applicable law, Agilent disclaims all warranties, either express or implied, with regard to this manual and any information contained herein, including but not limited to the implied warranties of merchantability and fitness for a particular purpose. Agilent shall not be liable for errors or for incidental or consequential damages in connection with the furnishing, use, or performance of this document or of any information contained herein. Should Agilent and the user have a separate written agreement with warranty terms covering the material in this document that conflict with these terms, the warranty terms in the separate agreement shall control.

Technology Licenses

The hardware and or software described in this document are furnished under a license and may be used or copied only in accordance with the terms of such license.

Restricted Rights Legend

U.S. Government Restricted Rights. Software and technical data rights granted to the federal government include only those rights customarily provided to end user customers. Agilent provides this customary commercial license in Software and technical data pursuant to FAR 12.211 (Technical Data) and 12.212 (Computer Software) and, for the Department of Defense, DFARS 252.227-7015 (Technical Data - Commercial Items) and DFARS 227.7202-3 (Rights in Commercial Computer Software or Computer Software Documentation).

Safety Notices

CAUTION









A **CAUTION** notice denotes a hazard. It calls attention to an operating procedure, practice, or the likes of that, if not correctly performed or adhered to, could result in damage to the product or loss of important data. Do not proceed beyond a **CAUTION** notice until the indicated conditions are fully understood and met.

WARNING

A **WARNING** notice denotes a hazard. It calls attention to an operating procedure, practice, or the likes of that, if not correctly performed or adhered to, could result in personal injury or death. Do not proceed beyond a **WARNING** notice until the indicated conditions are fully understood and met.

Safety Symbols

The following symbols on the instrument and in the documentation indicate precautions which must be taken to maintain safe operation of the instrument.

	DC (Direct current or voltage)		Caution, risk of danger (refer to this manual for specific Warning or Caution information)
	AC (Alternating current or voltage)		Application around and removal from HAZARDOUS LIVE conductors is permitted
	Both direct and alternating current	400 A MAX	U1191A/U1192A: Maximum allowable current measurement is 400 A
	Earth (ground) terminal	600 A MAX	U1193A/U1194A: Maximum allowable current measurement is 600 A
	Equipment protected throughout by double insulation or reinforced insulation	CAT III 600 V	Category III 600 V overvoltage protection
	Caution, risk of electric shock	CAT IV 300 V	Category IV 300 V overvoltage protection

Safety Considerations

Read the information below before using this instrument.

The following general safety precautions must be observed during all phases of operation, service, and repair of this instrument. Failure to comply with these precautions or with specific warnings elsewhere in this manual violates safety standards for design, manufacture, and intended use of the instrument. Agilent Technologies assumes no liability for the customer's failure to comply with these requirements.

CAUTION

- Disconnect circuit power and discharge all high-voltage capacitors before testing resistance, continuity, diodes, or capacitance.
- Use the proper terminals, function, and range for your measurements.
- This device is for use at altitudes of up to 2,000 m.
- Never measure voltage when current measurement is selected.
- Always use the specified battery type. The power for the meter is supplied with two standard AAA 1.5 V batteries. Observe the correct polarity markings before you insert the batteries to ensure proper insertion of the batteries in the meter.

WARNING

- **Do not use the meter if it is damaged. Before you use the meter, inspect the case. Look for cracks or missing plastic. Pay particular attention to the insulation surrounding the connectors.**
- **Inspect the test leads for damaged insulation or exposed metal. Check the test leads for continuity. Replace damaged test leads before you use the meter.**
- **Do not operate the meter around explosive gas, vapor, or wet environments.**
- **Do not apply more than the rated voltage and current (as marked on the meter) between the terminals or between the terminal and the earth ground.**

WARNING

- **Never use the meter in wet conditions or when there is water on the surface. If the meter is wet, ensure that the meter is dried only by trained personnel.**
 - **Before use, verify the meter's operation by measuring a known voltage. Use caution when working above 60 V DC, 30 V AC RMS, or 42.4 V peak. Such voltages pose a shock hazard.**
 - **When measuring current, turn off the circuit power before connecting the meter in the circuit. Remember to place the meter in series with the circuit.**
 - **When measuring temperature, keep the thermocouple probe as close to the meter as possible, and avoid contact with surfaces above 60 V DC, 30 V AC RMS, or 42.4 V peak. Such voltages pose a shock hazard.**
 - **When servicing the meter, use only the specified replacement parts.**
 - **When using the probes, keep your fingers behind the finger guards on the probes.**
 - **Connect the common test lead before you connect the live test lead. When you disconnect the leads, disconnect the live test lead first.**
 - **Remove the test leads from the meter before you open the battery cover. Do not operate the meter with the battery cover or portions of the cover removed or loosened.**
 - **To avoid false readings, which may lead to possible electric shock or personal injury, replace the battery as soon as the low-battery indicator appears and flashes.**
 - **Use the meter only as specified in this guide. Otherwise, the protection provided by the meter may be impaired.**
 - **Individual protective equipment must be used if hazardous live parts in the installation are accessible where measurement is to be carried out.**
 - **The tactile indicator, or barrier, indicates the limit of safe access of the handheld part.**
-

Environmental Conditions

This instrument is designed for indoor use and in an area with low condensation. The table below shows the general environmental requirements for this instrument.





Environmental condition	Requirement
Operating temperature	-10 °C to 50 °C
Operating humidity	Up to 80% RH (relative humidity) for temperature up to 30 °C, decreasing linearly to 50% RH at 50 °C
Storage temperature	-40 °C to 60 °C, 40% to 80% RH (without batteries)
Altitude	Up to 2000 meters
Pollution degree	Pollution Degree 2

NOTE

The U1190A Series Handheld Clamp Meter complies with the following safety and EMC requirements:

- IEC 61010-1:2001/EN 61010-1:2001
- IEC 61010-2-032:2002/EN 61010-2-032:2002
- CAN/CSA-C22.2 No. 61010-1-04
- CAN/CSA-C22.2 No. 61010-2-032-04
- ANSI/UL Std. No. 61010-1:2004
- IEC61326-1:2005/EN61326-1:2006
- Canada: ICES/NMB-001: Issue 4, June 2006
- Australia/New Zealand: AS/NZS CISPR 11:2004

Regulatory Markings

 <p>ISM 1-A</p>	<p>The CE mark is a registered trademark of the European Community. This CE mark shows that the product complies with all the relevant European Legal Directives.</p>	 <p>N10149</p>	<p>The C-tick mark is a registered trademark of the Spectrum Management Agency of Australia. This signifies compliance with the Australia EMC Framework regulations under the terms of the Radio Communication Act of 1992.</p>
<p>ICES/NMB-001</p>	<p>ICES/NMB-001 indicates that this ISM device complies with the Canadian ICES-001. Cet appareil ISM est conforme a la norme NMB-001 du Canada.</p>		<p>This instrument complies with the WEEE Directive (2002/96/EC) marking requirement. This affixed product label indicates that you must not discard this electrical or electronic product in domestic household waste.</p>
 <p>C US</p>	<p>The CSA mark is a registered trademark of the Canadian Standards Association.</p>		<p>This symbol indicates the time period during which no hazardous or toxic substance elements are expected to leak or deteriorate during normal use. Forty years is the expected useful life of the product.</p>

Waste Electrical and Electronic Equipment (WEEE) Directive 2002/96/EC

This instrument complies with the WEEE Directive (2002/96/EC) marking requirement. This affixed product label indicates that you must not discard this electrical or electronic product in domestic household waste.

Product Category:

With reference to the equipment types in the WEEE directive Annex 1, this instrument is classified as a “Monitoring and Control Instrument” product.

The affixed product label is as shown below.



Do not dispose in domestic household waste.

To return this unwanted instrument, contact your nearest Agilent Service Center, or visit

www.agilent.com/environment/product

for more information.

Declaration of Conformity (DoC)

The Declaration of Conformity (DoC) for this instrument is available on the Agilent website. You can search the DoC by its product model or description at the web address below.

<http://regulations.corporate.agilent.com/DoC/search.htm>

NOTE

If you are unable to search for the respective DoC, please contact your local Agilent representative.

THIS PAGE HAS BEEN INTENTIONALLY LEFT BLANK.

Table of Contents

1	Calibration Procedures	
	Agilent Calibration Services	2
	Closed-case calibration	2
	Calibration interval	3
	Other recommendations for calibration	3
	Recommended Test Equipment	4
	Basic Operating Test	5
	LCD backlight test	5
	LED flashlight test	5
	Display test	6
	Calibration Process	7
	Test Considerations	8
	Functional Tests	9
	Performance Verification Tests	14
	Using the Front Panel for Adjustments	18
	Adjustment considerations	18
	Adjustment procedure	19
	Valid adjustment input values	21
	Exiting the adjustment mode	23

2 Service and Maintenance

Troubleshooting	26
Returning the Instrument for Service	27
Replaceable Parts	28
To order replaceable parts	28
Types of Service Available	29
Extended service contracts	29
Obtaining Repair Service (Worldwide)	30

List of Figures

- Figure 1-1 LCD display screen 6
- Figure 1-2 Vsense test 10
- Figure 1-3 Current performance verification test setup 13
- Figure 1-4 Location of VR101 and VR102, and VR103 adjustment points 21

THIS PAGE HAS BEEN INTENTIONALLY LEFT BLANK.

List of Tables

Table 1-1	Recommended test equipment	4
Table 1-2	Vsense test	11
Table 1-3	DC current offset test	11
Table 1-4	AC current balancing test	13
Table 1-2	Performance verification tests	14
Table 1-2	Performance verification tests (continued)	15
Table 1-3	Open-case adjustment points	21
Table 1-4	Close-case adjustment inputs	22
Table 2-1	Operating checklist	26

THIS PAGE HAS BEEN INTENTIONALLY LEFT BLANK.



1 Calibration Procedures

Agilent Calibration Services	2
Closed-case calibration	2
Calibration interval	3
Other recommendations for calibration	3
Recommended Test Equipment	4
Basic Operating Test	5
LCD backlight test	5
LED flashlight test	5
Display test	6
Calibration Process	7
Test Considerations	8
Functional Tests	9
Performance Verification Tests	15
Using the Front Panel for Adjustments	19
Adjustment considerations	19
Adjustment procedure	20
Valid adjustment input values	22
Exiting the adjustment mode	25

This chapter contains procedures for verifying the instrument performance, as well as procedures for making adjustments (calibration) where necessary.



Agilent Calibration Services

When your instrument is due for calibration, contact your local Agilent Service Center for recalibration. See “[Types of Service Available](#)” on page 29 for more information on the various calibration services offered.

Closed-case calibration

The U1191A, U1192A, and U1193A handheld clamp meter features a closed-case electronic calibration. In other words, no internal electro-mechanical adjustment is required. This instrument calculates correction factors based on the input reference signals you feed into it during the calibration process. The new correction factors are stored in nonvolatile EEPROM memory until the next calibration (adjustment) is performed.

The contents of this nonvolatile EEPROM memory will not change even when the power is switched off.

NOTE

The U1194A handheld clamp meter requires a an open-case electronic calibration.

The U1194A handheld clamp meter requires additional electro-mechanical adjustment. See [Table 1-3](#), “Open-case adjustment points,” on page 22 for more information.

Calibration interval

The instrument should be calibrated on a regular interval determined by the measurement accuracy requirements of your application.

A one-year interval is adequate for most applications.

Accuracy specifications are warranted only if calibration is performed at regular intervals. Accuracy specifications are not warranted beyond the one-year calibration interval.

Agilent does not recommend extending calibration intervals beyond two years for any application.

Other recommendations for calibration

Specifications are only guaranteed within the specified period from the last calibration. Agilent recommends that readjustment should always be performed at whatever calibration interval you select. This will ensure that the instrument remains within its specifications until the next calibration. This calibration criterion provides the best long-term stability.

During performance verification tests, only the performance data is collected; these tests do not guarantee that the instrument will remain within the specified limits. The tests are only for identifying which functions need adjustment.

Recommended Test Equipment

The test equipment recommended for the performance verification and adjustment procedures is listed below in [Table 1-1](#). If the exact instrument is not available, substitute with another calibration standard of equivalent accuracy.

Table 1-1 Recommended test equipment





Application	Recommended equipment	Recommended accuracy requirement
DC voltage	Fluke 5520A	<20% of the instrument accuracy specification
DC current	Fluke 5520A and Fluke 5500A/COIL	<20% of the instrument accuracy specification
Resistance	Fluke 5520A	<20% of the instrument accuracy specification
AC voltage	Fluke 5520A	<20% of the instrument accuracy specification
AC current	Fluke 5520A and Fluke 5500A/COIL	<20% of the instrument accuracy specification
Frequency	Fluke 5520A	<20% of the instrument accuracy specification
Capacitance	Fluke 5520A	<20% of the instrument accuracy specification
Diode	Fluke 5520A	<20% of the instrument accuracy specification
Temperature	Fluke 5520A	<20% of the instrument accuracy specification
Short	Shorting plug — a dual banana plug with a copper wire shorting the two terminals	

Basic Operating Test

The tests listed below are used to test the basic operations of the instrument. Repair is required if the instrument fails the any of the tests.



- “LCD backlight test”
- “LED flashlight test”
- “Display test”

LCD backlight test

Power-on the clamp meter and press  (on the U1192A/U1193A/U1194A models) or  (on the U1191A model). Check that the LCD backlight is turned on. Press the / key again to turn the LCD backlight off.

LED flashlight test

For U1192A, U1193A, and U1194A models only:

Press and hold the  key for more than 1 second. Check that the LED flashlight is turned on. Press and hold the  key for more than 1 second again to turn the LED flashlight off.

Display test

Press and hold the  key while turning the rotary switch from the **OFF** position to any other position (**ON**). Check that all the annunciators are displayed in the LCD. Compare the display with the example shown in [Figure 1-1](#). All annunciators are displayed in the LCD for 10 seconds.

To exit this mode, please wait 10 seconds for the clamp meter to return to normal operation. Alternatively, you may cycle the clamp meter's power. The clamp meter will return to normal operation when it is turned on again.

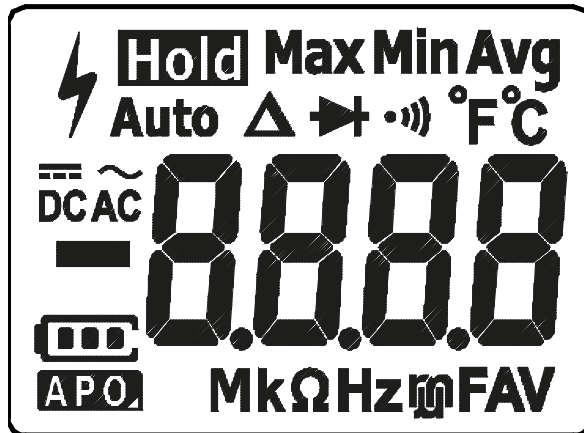

Figure 1-1 LCD display screen

Calibration Process

- 1 Prior to performing the verification tests, see “[Test Considerations](#)” on page 8.
- 2 Perform the functional tests to verify the following measurement functionality of the clamp meter; see “[Functional Tests](#)” on page 9.
- 3 Perform the verification tests to characterize the clamp meter; see “[Performance Verification Tests](#)” on page 15.
- 4 Prior to performing the adjustments, see “[Adjustment considerations](#)” on page 19.
- 5 Perform the adjustment procedure; see “[Adjustment procedure](#)” on page 20.
- 6 Ensure that the clamp meter is not in the adjustment mode and is turned off; see “[Exiting the adjustment mode](#)” on page 25.

Test Considerations

For optimum performance, all procedures should comply with the following recommendations:

- The performance verification test or adjustment should be performed under a laboratory condition, where the ambient temperature can be controlled.
- Ensure that the calibration ambient temperature is stable and is between 18 °C and 28 °C. Ideally the calibration should be performed at 23 °C ± 1 °C.
- Ensure that the ambient relative humidity is less than 80%.
- The instrument should be in the laboratory environment for at least 1 hour prior.
- Allow a warm-up period of 3 minutes.
- Use shielded twisted-pair PTFE-insulated cables to reduce settling and noise errors. Keep the input cables as short as possible.

Functional Tests

Use the functional tests to verify the following measurement functionality of the instrument.

- “[Vsense test](#)” on page 9
- “[DC current offset test](#)” on page 11
- “[AC current balancing test](#)” on page 12

Vsense test

This test is for U1192A, U1193A, and U1194A models only. Use the following procedure to verify that Vsense is functional.

NOTE

- Keep the clamp meter away from electrical noise sources (that include fluorescent lights, dimmable lights, motors, and so on) during the tests. These sources can trigger the Vsense alert and invalidate the test.
 - It may be necessary to slightly adjust the clamp meter’s position for maximum signal strength, in order to get the clamp meter’s beeper to sound continuously.
-

1 Calibration Procedures

Functional Tests

CAUTION

Do not touch the dual banana plug with your hand while the calibrator output is turned on.

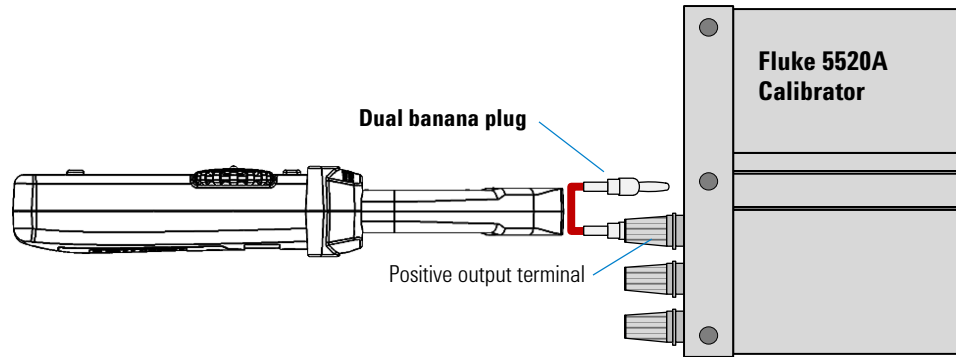

Figure 1-2 Vsense test



- 1 Connect a dual banana plug to the output voltage terminals of the calibrator.

NOTE

Ensure that the Fluke 5520A calibrator output is disabled when connecting the dual banana plug.

- 2 Set the Fluke 5520A calibrator output to the values shown in [Table 1-2](#) on page 11, and enable the Fluke 5520A calibrator output.
- 3 Hold the clamp meter so that the top of the clamp meter is vertically and horizontally centered and in contact with the banana plug's Hi terminal.

Table 1-2 Vsense test

Step	Test function	Range	Fluke 5520A output	Vsense alert status
1	Vsense Turn the rotary switch to the  position.	Hi.SE	5 V, 60 Hz	No alert
			8 V, 60 Hz	Alert on
	Press  to switch to Lo.SE.	Lo.SE	18 V, 60 Hz	No alert
			24 V, 60 Hz	Alert on

4 Adjustment or repair is required if the clamp meter fails any of the Vsense functional tests. See “[Close-case adjustment](#)” on page 24.

DC current offset test

This test is for U1194A models only.

- 1 Place the clamp meter at a stationary position. Keep the clamp jaw closed without any conductor inside the jaw.
- 2 Turn the rotary switch of the clamp meter to the DC current function.
- 3 Verify that the measured readings fall within the specified error limits from the reference value as stated in [Table 1-3](#). Repair is required if the clamp meter fails this test. See “[Open-case adjustment \(U1194A only\)](#)” on page 22.

Table 1-3 DC current offset test

Step	Test function	Range	Reference input value	Error limit ^[1]
1	DC current	40 A	0.00 A	±0.10 A

[1] Specified after the Null function is turned on.

AC current balancing test

This test is for U1194A models only.

- 1 Place the clamp meter on to a Fluke 5500A/COIL 50-turn current coil as shown in [Figure 1-3](#), “Current performance verification test setup,” on page 14.
- 2 Set the Fluke 5520A calibrator output to the values shown in [Table 1-4](#) on page 14, and enable the Fluke 5520A calibrator output.
- 3 Check that the position of the conductor relative to the clamp meter is in position 0 as shown in the figure below.

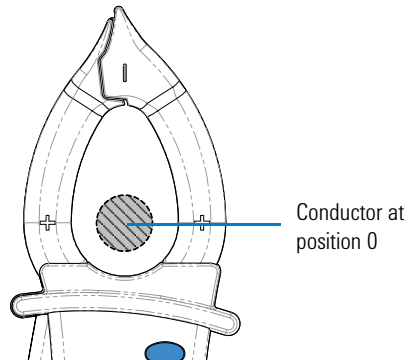

- 4 Record the current reading at position 0.
- 5 Slowly move the clamp meter so that the conductor is in position 1 as shown in the figure on the next page. Ensure that the conductor position is close to the top of the jaw.

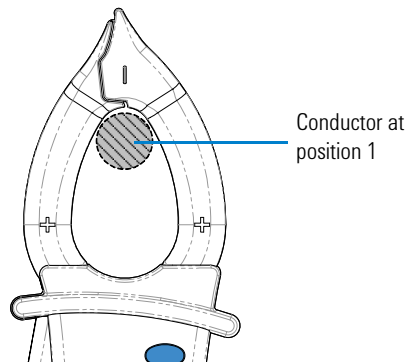

- 6 Record the current reading at position 1.
- 7 Slowly move the clamp meter so that the conductor is in position 2 as shown in the figure below. Ensure that the conductor position is close to the bottom of the jaw.

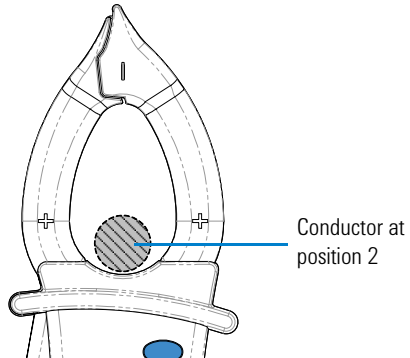

- 8 Record the current reading at position 2.
- 9 Calculate the difference between the readings at position 0 and position 1, and the difference between the readings at position 0 and position 2. Check if the difference falls within the specified error limits in [Table 1-4](#). Adjustment is required if the clamp meter fails this test.

1 Calibration Procedures

Functional Tests

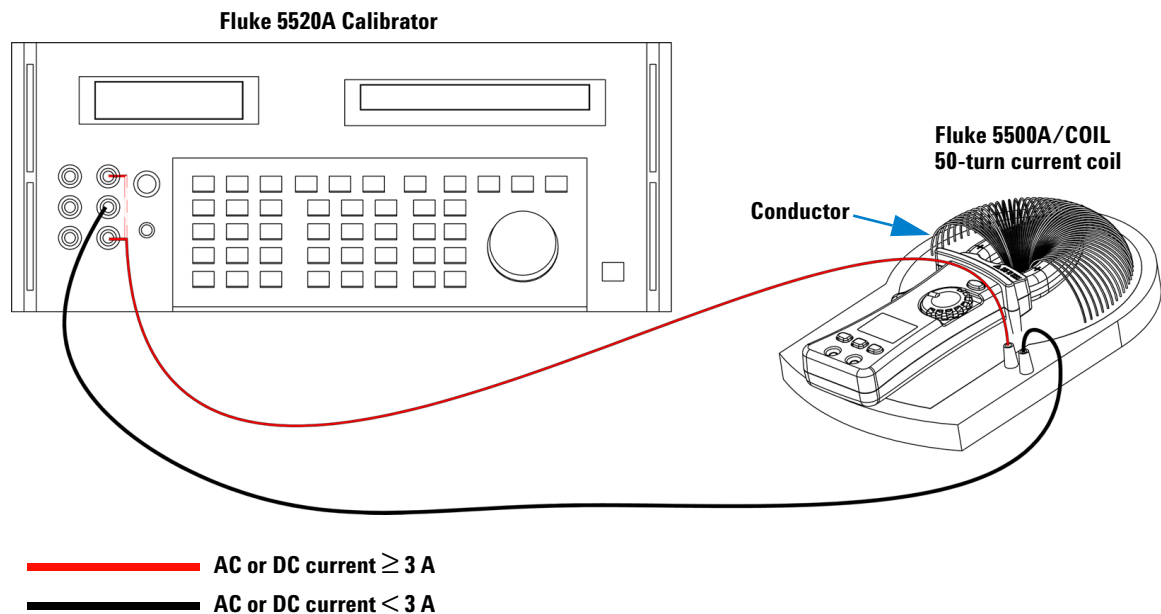

Figure 1-3 Current performance verification test setup

Table 1-4 AC current balancing test

Step	Test function	Fluke 5520A output used with Fluke 5500A/COIL	Reference input value	Error limit
1	AC current	2 A, 60 Hz	100.0 A, 60 Hz	± 1.0 A

Performance Verification Tests

Use the performance verification tests to verify the measurement performance of the instrument. The performance verification tests use the instrument's specifications listed in the *U1190A Series User's Guide* (available for download at www.agilent.com/find/hhTechLib).

The performance verification tests are recommended as acceptance tests when you first receive the instrument. The acceptance test results should be compared against the one-year test limits. After acceptance, you should repeat the performance verification tests at every calibration interval.

If the clamp meter fails the performance verification tests, adjustment or repair is required.

NOTE

Ensure that you have read the “Test Considerations” on page 8 before running the performance verification tests.

Table 1-2 Performance verification tests

Step	Test function	Range	Fluke 5520 output	Reference values	Error from nominal 1 year			
					U1191A	U1192A	U1193A	U1194A
1	ACA Turn the rotary switch to the Hz  A position.	60 A	1.2 A, 45 Hz	60 A, 45 Hz	-	±1.25 A	±1.25 A	±1.25 A
			1.2 A, 400 Hz	60 A, 400 Hz	-	±1.85 A	±1.85 A	±1.85 A
		400 A	8 A, 45 Hz	400 A, 45 Hz	±8.5 A	±8.5 A	-	-
			8 A, 400 Hz	400 A, 400 Hz	±12.5 A	±12.5 A	-	-
		600 A	12 A, 45 Hz	600 A, 45 Hz	-	-	±12.5 A	±12.5 A
			12 A, 100 Hz	600 A, 100 Hz	-	-	±18.5 A	±18.5 A

1 Calibration Procedures

Performance Verification Tests

Table 1-2 Performance verification tests (continued)



Step	Test function	Range	Fluke 5520 output	Reference values	Error from nominal 1 year			
					U1191A	U1192A	U1193A	U1194A
2	DCA Turn the rotary switch to the Hz  A position, and press the  key until DC is shown on the display.	60 A	1.2 A	60 A	-	-	-	±1.25 A
		600 A	12 A	600 A	-	-	-	±12.5 A

Table 1-2 Performance verification tests (continued)













Step	Test function	Range	Fluke 5520 output	Error from nominal 1 year			
				U1191A	U1192A	U1193A	U1194A
3	ACV Turn the rotary switch to the Hz  V position.	60 V	60 V, 45 Hz	-	±0.77 V	±0.77 V	±0.77 V
			60 V, 500 Hz	-	±0.77 V	±0.77 V	±0.77 V
		600 V	600 V, 45 Hz	±7.7 V	±7.7 V	±7.7 V	±7.7 V
			600 V, 500 Hz	±7.7 V	±7.7 V	±7.7 V	±7.7 V
4	Frequency Turn the rotary switch to the Hz  V position, and press the  key once.	9.999 kHz	1 kHz, 6 V	±0.008 kHz	±0.008 kHz	±0.008 kHz	±0.008 kHz
5	DCV Turn the rotary switch to the DC  V position.	60 V	60 V	-	±0.33 V	±0.33 V	±0.33 V
		600 V	600 V	±3.3 V	±3.3 V	±3.3 V	±3.3 V



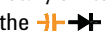

Table 1-2 Performance verification tests (continued)

Step	Test function	Range	Fluke 5520 output	Error from nominal 1 year			
				U1191A	U1192A	U1193A	U1194A
6	Resistance Turn the rotary switch to the  Ω position.	600 Ω ^[1]	600 Ω	±5.3 Ω	±5.3 Ω	±5.3 Ω	±5.3 Ω
		6 kΩ ^[1]	6 kΩ	±0.051 kΩ	±0.051 kΩ	±0.051 kΩ	±0.051 kΩ
		60 kΩ	60 kΩ	-	±0.51 kΩ	±0.51 kΩ	±0.51 kΩ
<p>[1] The accuracy is specified after the Null function is used to subtract the test lead resistance and thermal effect (by shorting the test leads). Apply a 0 Ω calibrator output, and allow the clamp meter to settle before pressing the  key.</p>							
7	Diode Turn the rotary switch to the  position.	1.5 V	1.5 V	±0.018 V	±0.018 V	±0.018 V	±0.018 V
8	Capacitance Turn the rotary switch to the  position, and press the  key once.	600 μF	600 μF	-	±12.4 μF	±12.4 μF	±12.4 μF
		6 mF	6 mF	-	±0.124 mF	±0.124 mF	±0.124 mF
9	Temperature ^[2] Turn the rotary switch to the  position, and press the  key until  is shown on the display.	-40 °C to 400 °C	0 °C	-	-	-	±2.0 °C
		-400 °C to 1200 °C	400 °C	-	-	-	±6 °C
<p>[2] Ensure that the ambient temperature is stable within ±1 °C. Ensure that the clamp meter is placed in a controlled environment for at least 1 hour before you proceed to ensure that the clamp meter's internal reference junction sensor and input terminal are stabilized at the same environment. Keep the clamp meter away from any ventilation exit.</p> <p>Differences in ambient compensation between the calibrator and clamp meter may cause some deviations shown between the readings of the calibrator and clamp meter. Placing the clamp meter close to the output terminal of the calibrator will help reduce this deviation.</p> <p>Keep the thermocouple test lead as close to the clamp meter as possible.</p> <p>Do not touch the thermocouple test lead after connecting it to the calibrator. Allow the connection to stabilize for at least another 15 minutes before performing the measurement.</p>							

1 Calibration Procedures

Performance Verification Tests

Table 1-2 Performance verification tests (continued)

Step	Test function	Range	Fluke 5520 output	Error from nominal 1 year			
				U1191A	U1192A	U1193A	U1194A
10	DC μ A Turn the rotary switch to the  position, and press the  key until DC is shown on the display.	60 μ A	60 μ A	-	-	-	$\pm 0.65 \mu$ A
		600 μ A	600 μ A	-	-	-	$\pm 6.5 \mu$ A
11	AC μ A Turn the rotary switch to the  position, and press the  key until AC is shown on the display.	60 μ A	60 μ A, 45 Hz	-	-	-	$\pm 0.65 \mu$ A
			60 μ A, 500 Hz	-	-	-	$\pm 0.65 \mu$ A
		600 μ A	600 μ A, 45 Hz	-	-	-	$\pm 6.5 \mu$ A
			600 μ A, 500 Hz	-	-	-	$\pm 6.5 \mu$ A

Using the Front Panel for Adjustments

This section describes the procedures to perform adjustments from the front panel.

Adjustment considerations

- 1 Allow the instrument to warm up and stabilize for 3 minutes before performing the adjustments.
- 2 Check that the battery level is at least at two bars before performing any adjustments. This ensures that during the adjustments, the low-battery indicator does not appear.
If the low-battery indicator appears, replace the batteries as soon as possible to avoid false readings.
- 3 Consider the thermal effects as you are connecting the test leads to the calibrator and handheld clamp meter. Agilent recommends you to wait for 1 minute before you begin the calibration after connecting the test leads.
- 4 Before proceeding with the ambient temperature adjustment, be sure to turn on the clamp meter for at least 1 hour with the K-type thermocouple connected.

CAUTION

Never turn off the clamp meter during an adjustment. This may delete the calibration memory for the present function.



1 Calibration Procedures

Using the Front Panel for Adjustments

Adjustment procedure

NOTE

Review the “[Test Considerations](#)” and “[Adjustment considerations](#)” before beginning the adjustment procedures.

- 1 Press and hold the  and  keys while turning the rotary switch from the **OFF** position to any other position (**ON**) to enter the adjustment mode.

The **Auto** annunciator will flash continuously to indicate that the clamp meter is now in the adjustment mode.





NOTE

If the **Auto** annunciator is not flashing, repeat [step 1](#). If the error persists, please contact your nearest Agilent Service Center.

- 2 Turn the rotary switch to the respective test function position as shown in the adjustment input values table ([Table 1-4](#)). Press  to switch between the **primary** and the **shift** (icons printed in **orange**) functions.
- 3 Apply the input signal shown in the Reference Value column of [Table 1-4](#). Determine if the signal is within the valid reference input range.

NOTE

You are highly recommended to complete the adjustments in the same order as shown in the appropriate table.

- 4 Press the / key to save the calibration reference value when a stable reading is achieved on the display. If the adjustment fails, **Err** will be shown on the display. Press the / key again to return to the current calibration item.

NOTE

If the adjustment fails, check the input value and function before repeating the adjustment steps.

- 5 Turn the rotary switch to the next function according to the Test Function column shown in [Table 1-4](#). Repeat [step 2](#) to [step 4](#) for each adjustment point shown in the adjustment table.
- 6 Verify the adjustments using the “[Performance Verification Tests](#)” on page 15.

NOTE

While in the adjustment mode, turn the rotary switch to the **OFF** position to exit the adjustment mode.

1 Calibration Procedures

Using the Front Panel for Adjustments

Valid adjustment input values

NOTE

Connect a 3 V DC power source to the clamp meter before carrying out the adjustment. Ensure that the polarity of the connection is correct.

Adjustment can be accomplished using the following input values below.

Open-case adjustment (U1194A only)

Table 1-3 Open-case adjustment points

Test function	Step	Reference value	Limit	Adjustment point
DC current offset test ^[1]	40 A	0.00 A	0.10 A	VR101, VR102
[1] Adjust the VR101 and VR102 adjustment points (see Figure 1-4) until the error is within the limit.				
AC current balancing test ^[2]	400 A	100.0 A, 60 Hz	0.2 A	VR103
[2] Adjust the VR103 adjustment point (see Figure 1-4) until the error is within the limit.				

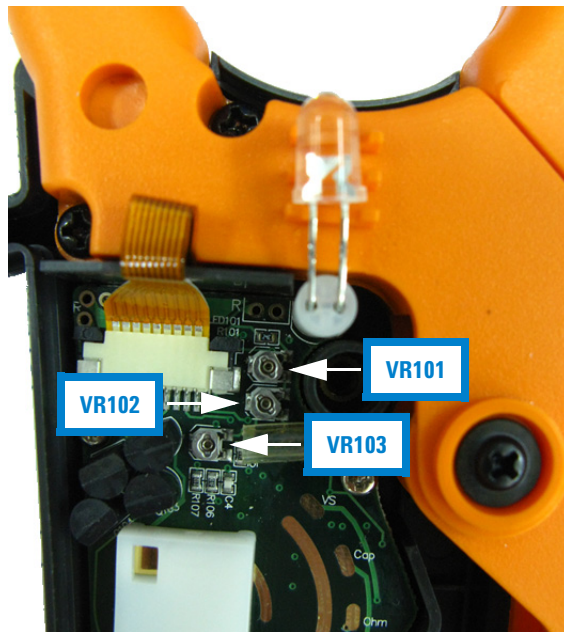

Figure 1-4 Location of VR101 and VR102, and VR103 adjustment points

1 Calibration Procedures

Using the Front Panel for Adjustments

Close-case adjustment

Table 1-4 Close-case adjustment inputs

Test function	Reference value	U1191A	U1192A	U1193A	U1194A	Valid reference input
DCV	50.00 V	-	✓	✓	✓	0.9 to 1.1 × Reference value
	500.0 V	✓	✓	✓	✓	0.9 to 1.1 × Reference value
ACV	50.00 V, 60 Hz	-	✓	✓	✓	0.9 to 1.1 × Reference value
	500.0 V, 60 Hz	✓	✓	✓	✓	0.9 to 1.1 × Reference value
ACA	50.00 A, 50 Hz	-	✓	✓	✓	0.75 to 1.25 × Reference value
	240.0 A, 50 Hz	✓	✓	✓	✓	0.75 to 1.25 × Reference value
DCA	50.00 A ^[1]	-	-	-	✓	0.75 to 1.25 × Reference value
	240.0 A ^[1]	-	-	-	✓	0.75 to 1.25 × Reference value

[1] Move the clamp meter away from the signal, and press the  key to zero the offset.

AC μ A	50.00 μ A, 60 Hz	-	-	-	✓	0.9 to 1.1 × Reference value
	500.0 μ A, 60 Hz	-	-	-	✓	0.9 to 1.1 × Reference value
DC μ A	50.00 μ A	-	-	-	✓	0.9 to 1.1 × Reference value
	500.0 μ A	-	-	-	✓	0.9 to 1.1 × Reference value
Resistance	500.0 Ω ^[2]	✓	✓	✓	✓	0.9 to 1.1 × Reference value
	5.000 k Ω ^[2]	✓	✓	✓	✓	0.9 to 1.1 × Reference value
	50.00 k Ω	-	✓	✓	✓	0.9 to 1.1 × Reference value

[2] Short the input terminals, and press the  key to zero the offset.

Continuity	500.0 Ω	✓	✓	✓	✓	0.9 to 1.1 × Reference value
Diode	1.000 V	✓	✓	✓	✓	0.9 to 1.1 × Reference value
Capacitance	1.000 mF	-	✓	✓	✓	0.9 to 1.1 × Reference value

Table 1-4 Close-case adjustment inputs (continued)

Test function	Reference value	U1191A	U1192A	U1193A	U1194A	Valid reference input
Temperature	12.209 mV	-	-	-	✓	0.9 to 1.1 × Reference value
	45.119 mV	-	-	-	✓	0.9 to 1.1 × Reference value
	0 °C ^[3]	-	-	-	✓	0.9 to 1.1 × Reference value
[3] Ensure the clamp meter is turned on and stabilized for at least 1 hour with the thermocouple connected between the clamp meter and the calibrator output terminal.						
Vsense (Hi.SE)	9 V, 60 Hz	-	✓	✓	✓	N/A
Vsense (Lo.SE)	27 V, 60 Hz	-	✓	✓	✓	N/A

Exiting the adjustment mode

- 1 Remove all the shorting plugs and connectors from the instrument.
- 2 Power off and on again.

1 Calibration Procedures

Using the Front Panel for Adjustments

THIS PAGE HAS BEEN INTENTIONALLY LEFT BLANK.



2 Service and Maintenance

Troubleshooting	26
Returning the Instrument for Service	27
Replaceable Parts	28
To order replaceable parts	28
Types of Service Available	29
Extended service contracts	29
Obtaining Repair Service (Worldwide)	30

This chapter will help you troubleshoot a failing instrument. It also describes how to obtain repair services and lists the replaceable assemblies.



Troubleshooting



WARNING

To avoid electrical shock, do not perform any service unless you are qualified to do so.

If the instrument fails to operate, check the batteries and the test leads. Replace them if necessary. And if the instrument still does not function, check the operating procedures in this manual. When servicing, use only the specified replacement parts.

The table below will assist you in identifying some basic malfunctions.

Table 2-1 Operating checklist

Malfunction	Identification
No display when powered ON using the rotary switch	<input type="checkbox"/> Verify the batteries health and replace batteries as necessary.
Auto powered OFF after powered ON for a while	<input type="checkbox"/> Verify the auto power-off (APO) function is enabled in the clamp meter's Setup mode.
No backlight when the  /  key is pressed.	<input type="checkbox"/> Verify that the backlight function is enabled in the clamp meter's Setup mode.
No flashlight when the  is pressed for more than 1 second.	<input type="checkbox"/> Verify that the flashlight function is enabled in the clamp meter's Setup mode.
No continuity visual alert (flashing backlight when measuring less than the threshold resistance)	<input type="checkbox"/> Verify that the continuity visual alert is enabled in the clamp meter's Setup mode.

Returning the Instrument for Service

Before shipping your instrument for repair or replacement, Agilent recommends that you acquire the shipping instructions from the Agilent Technologies Service Center. A clear understanding of the shipping instructions is necessary to secure your product for shipment.

1 Attach a tag to the instrument with the following information:

- Name and address of owner
- Instrument model number
- Instrument serial number
- Description of the service required or failure indications

2 Remove all accessories from the instrument. Do not include accessories unless they are associated with the failure symptoms.

3 Place the instrument in its original container with appropriate packaging material for shipping.

If the original shipping container is not available, place your unit in a container that will ensure at least 4 inches of compressible packaging material around all sides for the instrument. Use static-free packaging materials to avoid additional damage to your unit.

NOTE

Agilent suggests that you always insure your shipments.

Replaceable Parts

This section contains information for ordering replacement parts for your instrument. You can find the instrument support parts list in the *Agilent's Test & Measurement Parts Catalog* at <http://www.agilent.com/find/parts>

The parts lists include a brief description of each part with the applicable Agilent part number.

To order replaceable parts

You can order replaceable parts from Agilent using the Agilent part number. Note that not all parts listed are available as field-replaceable parts.

To order replaceable parts from Agilent, do the following:

- 1** Contact your nearest Agilent Sales Office or Service Center.
- 2** Identify the parts by the Agilent part number shown in the support parts list.
- 3** Provide the instrument model number and serial number.

Types of Service Available

If your instrument fails during the warranty period, Agilent Technologies will repair or replace it under the terms of your warranty.

Extended service contracts

Many Agilent products are available with optional service contracts that extend the covered period after the standard warranty expires. If you have such a service contract and your instrument fails during the covered period, Agilent Technologies will repair or replace it in accordance with the contract.

Obtaining Repair Service (Worldwide)

To obtain service for your instrument (in-warranty or under service contract), contact your nearest Agilent Technologies Service Center. They will arrange to have your unit repaired or replaced, and can provide warranty information where applicable.

To obtain warranty, service, or technical support information, you can contact Agilent Technologies at one of the following telephone numbers:

- In the United States: (800) 829-4444
- In Europe: 31 20 547 2111
- In Japan: 0120-421-345

Or use our web link for information on contacting Agilent worldwide: www.agilent.com/find/assist

Or contact your Agilent Technologies Representative.

Before shipping your instrument, ask the Agilent Technologies Service Center to provide shipping instructions, including what components to ship. Agilent recommends that you retain the original shipping carton for use in such shipments.

www.agilent.com

Contact us

To obtain service, warranty, or technical assistance, contact us at the following phone or fax numbers:

United States:

(tel) 800 829 4444 (fax) 800 829 4433

Canada:

(tel) 877 894 4414 (fax) 800 746 4866

China:

(tel) 800 810 0189 (fax) 800 820 2816

Europe:

(tel) 31 20 547 2111

Japan:

(tel) (81) 426 56 7832 (fax) (81) 426 56 7840

Korea:

(tel) (080) 769 0800 (fax) (080) 769 0900

Latin America:

(tel) (305) 269 7500

Taiwan:

(tel) 0800 047 866 (fax) 0800 286 331

Other Asia Pacific Countries:

(tel) (65) 6375 8100 (fax) (65) 6755 0042

Or visit Agilent World Wide Web at:

www.agilent.com/find/assist

Product specifications and descriptions in this document are subject to change without notice. Always refer to the Agilent website for the latest revision.

© Agilent Technologies, Inc., 2012–2013

Third Edition, April 3, 2013
U1191-90014



Agilent Technologies